

## FCC Test Report

Product Name	Fanless Medical Grade Box PC
Model No.	xxxMEDPC-6200xxxxxxxxxx (The x can be 0 to 9 , a to z , A to Z ,”-“, or blank for marketing purpose)
FCC ID.	RZ5-MEDPC-6200

Applicant	ONYX HEALTHCARE INC.
Address	2F., NO.135, LANE 235, PAO CHIAO RD., XINDIAN DIST., NEW TAIPEI CITY 231, TAIWAN (R.O.C.)

Date of Receipt	Aug. 08, 2017
Issued Date	Oct. 18, 2017
Report No.	1780161R-RFUSP01V00
Report Version	V1.0



The test results relate only to the samples tested.

The test results shown in the test report are traceable to the national/international standard through the calibration report of the equipment and evaluated measurement uncertainty herein.

This report must not be used to claim product endorsement by TAF or any agency of the government.

The test report shall not be reproduced without the written approval of DEKRA Testing and Certification Co., Ltd.

# Test Report

Issued Date: Oct. 18, 2017

Report No.: 1780161R-RFUSP01V00



Product Name	Fanless Medical Grade Box PC
Applicant	ONYX HEALTHCARE INC.
Address	2F., NO.135, LANE 235, PAO CHIAO RD., XINDIAN DIST., NEW TAIPEI CITY 231, TAIWAN (R.O.C.)
Manufacturer	ONYX HEALTHCARE INC.
Model No.	xxxMEDPC-6200xxxxxxxxxx (The x can be 0 to 9 , a to z , A to Z ,"-", or blank for marketing purpose)
FCC ID.	RZ5-MEDPC-6200
EUT Rated Voltage	AC 100-240V, 50/60Hz
EUT Test Voltage	AC 120V/60Hz
Trade Name	onyx
Applicable Standard	FCC CFR Title 47 Part 15 Subpart C: 2016 ANSI C63.4: 2014, ANSI C63.10: 2013
Test Result	Complied

Documented By :



( Senior Adm. Specialist / Genie Chang )

Tested By :

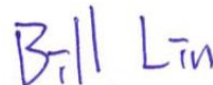

( Engineer / Bill Lin )

Approved By :



( Director / Vincent Lin )

## TABLE OF CONTENTS

Description	Page
<b>1. GENERAL INFORMATION .....</b>	<b>5</b>
1.1. EUT Description.....	5
1.2. Operational Description.....	7
1.3. Tested System Details.....	8
1.4. Configuration of Tested System .....	8
1.5. EUT Exercise Software .....	8
1.6. Test Facility .....	9
1.7. List of Test Equipment.....	10
<b>2. CONDUCTED EMISSION .....</b>	<b>11</b>
2.1. Test Setup .....	11
2.2. Limits.....	11
2.3. Test Procedure .....	12
2.4. Uncertainty .....	12
2.5. Test Result of Conducted Emission.....	13
<b>3. PEAK POWER OUTPUT .....</b>	<b>17</b>
3.1. Test Setup .....	17
3.2. Limit .....	17
3.3. Test Procedure .....	17
3.4. Uncertainty .....	17
3.5. Test Result of Peak Power Output.....	18
<b>4. RADIATED EMISSION .....</b>	<b>20</b>
4.1. Test Setup .....	20
4.2. Limits.....	21
4.3. Test Procedure .....	22
4.4. Uncertainty .....	22
4.5. Test Result of Radiated Emission.....	23
<b>5. RF ANTENNA CONDUCTED TEST .....</b>	<b>33</b>
5.1. Test Setup .....	33
5.2. Limits.....	33
5.3. Test Procedure .....	33
5.4. Uncertainty .....	33
5.5. Test Result of RF Antenna Conducted Test.....	34
<b>6. BAND EDGE .....</b>	<b>36</b>
6.1. Test Setup .....	36
6.2. Limit .....	37
6.3. Test Procedure .....	37
6.4. Uncertainty .....	37
6.5. Test Result of Band Edge .....	38
<b>7. CHANNEL NUMBER.....</b>	<b>50</b>
7.1. Test Setup .....	50
7.2. Limit .....	50
7.3. Test Procedure .....	50
7.4. Uncertainty .....	50
7.5. Test Result of Channel Number.....	51
<b>8. CHANNEL SEPARATION.....</b>	<b>53</b>
8.1. Test Setup .....	53
8.2. Limit .....	53
8.3. Test Procedure .....	53
8.4. Uncertainty .....	53
8.5. Test Result of Channel Separation.....	54
<b>9. DWELL TIME.....</b>	<b>58</b>
9.1. Test Setup .....	58
9.2. Limit .....	58
9.3. Test Procedure .....	58
9.4. Uncertainty .....	58
9.5. Test Result of Dwell Time.....	59
<b>10. OCCUPIED BANDWIDTH .....</b>	<b>63</b>
10.1. Test Setup .....	63

---

10.2.	Limits.....	63
10.3.	Test Procedure .....	63
10.4.	Uncertainty .....	63
10.5.	Test Result of Occupied Bandwidth .....	64
<b>11.</b>	<b>EMI REDUCTION METHOD DURING COMPLIANCE TESTING .....</b>	<b>68</b>
Attachment 1: EUT Test Photographs		
Attachment 2: EUT Detailed Photographs		

## 1. GENERAL INFORMATION

### 1.1. EUT Description

Product Name	Fanless Medical Grade Box PC
Trade Name	onyx
Model No.	xxxMEDPC-6200xxxxxxxxxx (The x can be 0 to 9 , a to z , A to Z ,”-“, or blank for marketing purpose)
FCC ID.	RZ5-MEDPC-6200
Frequency Range	2402 – 2480MHz
Channel Number	79
Type of Modulation	FHSS: GFSK(1Mbps) / $\pi$ /4DQPSK(2Mbps) / 8DPSK(3Mbps)
Antenna Type	Dipole Antenna
Channel Control	Auto
Antenna Gain	Refer to the table “Antenna List”
Power Adapter (1)	M/N: ATM020-W050U Input: AC 100-240V~50-60Hz 0.45-0.27A Output: DC 5V, 3.5A Cable Out: Non-shielded, 1.8m
Power Adapter (2)	M/N: ATM036T-A050 Input: AC 100-240V~50-60Hz 1A-0.45 Output: DC 5V, 5A Cable IN: Non-shielded, 1.8m Cable Out: Non-shielded, 1.5m

#### Antenna List

No.	Manufacturer	Part No.	Antenna Type	Peak Gain
1	ARISTOTLE	RFA-02-C2M2-M32-3	Dipole Antenna	2.42dBi for WLAN
2	ARISTOTLE	RFA-02-C2M2-M32-3	Dipole Antenna	2.42dBi for Bluetooth

Note: The antenna of EUT is conforming to FCC 15.203.

Center Frequency of Each Channel:

Channel	Frequency	Channel	Frequency	Channel	Frequency	Channel	Frequency
Channel 00:	2402 MHz	Channel 20:	2422 MHz	Channel 40:	2442 MHz	Channel 60:	2462 MHz
Channel 01:	2403 MHz	Channel 21:	2423 MHz	Channel 41:	2443 MHz	Channel 61:	2463 MHz
Channel 02:	2404 MHz	Channel 22:	2424 MHz	Channel 42:	2444 MHz	Channel 62:	2464 MHz
Channel 03:	2405 MHz	Channel 23:	2425 MHz	Channel 43:	2445 MHz	Channel 63:	2465 MHz
Channel 04:	2406 MHz	Channel 24:	2426 MHz	Channel 44:	2446 MHz	Channel 64:	2466 MHz
Channel 05:	2407 MHz	Channel 25:	2427 MHz	Channel 45:	2447 MHz	Channel 65:	2467 MHz
Channel 06:	2408 MHz	Channel 26:	2428 MHz	Channel 46:	2448 MHz	Channel 66:	2468 MHz
Channel 07:	2409 MHz	Channel 27:	2429 MHz	Channel 47:	2449 MHz	Channel 67:	2469 MHz
Channel 08:	2410 MHz	Channel 28:	2430 MHz	Channel 48:	2450 MHz	Channel 68:	2470 MHz
Channel 09:	2411 MHz	Channel 29:	2431 MHz	Channel 49:	2451 MHz	Channel 69:	2471 MHz
Channel 10:	2412 MHz	Channel 30:	2432 MHz	Channel 50:	2452 MHz	Channel 70:	2472 MHz
Channel 11:	2413 MHz	Channel 31:	2433 MHz	Channel 51:	2453 MHz	Channel 71:	2473 MHz
Channel 12:	2414 MHz	Channel 32:	2434 MHz	Channel 52:	2454 MHz	Channel 72:	2474 MHz
Channel 13:	2415 MHz	Channel 33:	2435 MHz	Channel 53:	2455 MHz	Channel 73:	2475 MHz
Channel 14:	2416 MHz	Channel 34:	2436 MHz	Channel 54:	2456 MHz	Channel 74:	2476 MHz
Channel 15:	2417 MHz	Channel 35:	2437 MHz	Channel 55:	2457 MHz	Channel 75:	2477 MHz
Channel 16:	2418 MHz	Channel 36:	2438 MHz	Channel 56:	2458 MHz	Channel 76:	2478 MHz
Channel 17:	2419 MHz	Channel 37:	2439 MHz	Channel 57:	2459 MHz	Channel 77:	2479 MHz
Channel 18:	2420 MHz	Channel 38:	2440 MHz	Channel 58:	2460 MHz	Channel 78:	2480 MHz
Channel 19:	2421 MHz	Channel 39:	2441 MHz	Channel 59:	2461 MHz		

Note:

1. The EUT is a Fanless Medical Grade Box PC with a 2.4GHz WLAN \ Bluetooth transceiver, this report for Bluetooth
2. These tests were conducted on a sample for the purpose of demonstrating compliance of Bluetooth transmitter with Part 15 Subpart C Paragraph 15.247 for spread spectrum devices.
3. Regarding to the operation frequency, the lowest, middle and highest frequency are selected to perform the test.
4. The radiation measurements are performed in X, Y, Z axis positioning. Only the worst case is shown in the report.
5. Bluetooth operation was evaluated at both 1Mb/s and 3Mb/s data rates. 2Mb/s data rate was found, through pre-testing, to produce emissions similar to those for 3Mb/s.

Test Mode	Mode 1: Transmit - 1Mbps Mode 2: Transmit - 3Mbps
-----------	--

### 1.3. Tested System Details

The types for all equipment, plus descriptions of all cables used in the tested system (including inserted cards) are:

Product	Manufacturer	Model No.	Serial No.	Power Cord	
1	Notebook PC	DELL	P62G	229FJC2	N/A
2	Monitor	DELL	U2415	CN-01RMGX-74261-63H-09UL-A02	N/A
3	USB 3.0	WD	WDBUZG0010BBK-PESN	WX11A166S2Y3	N/A
4	USB 3.0	WD	WDBUZG0010BBK-PESN	WXR1AC5478U6	N/A
5	Mouse	Logitech	U0026	N/A	N/A
6	Keyboard	Logitech	K120	N/A	N/A

Signal Cable Type	Signal cable Description
A	HDD USB 3.0 Cable
B	HDD USB 3.0 Cable
C	USB Keyboard Cable
D	USB Moue Cable
E	HDM Cable
F	USB Cable (Signal Cable)
G	USB Cable (Signal Cable)

### 1.4. Configuration of Tested System

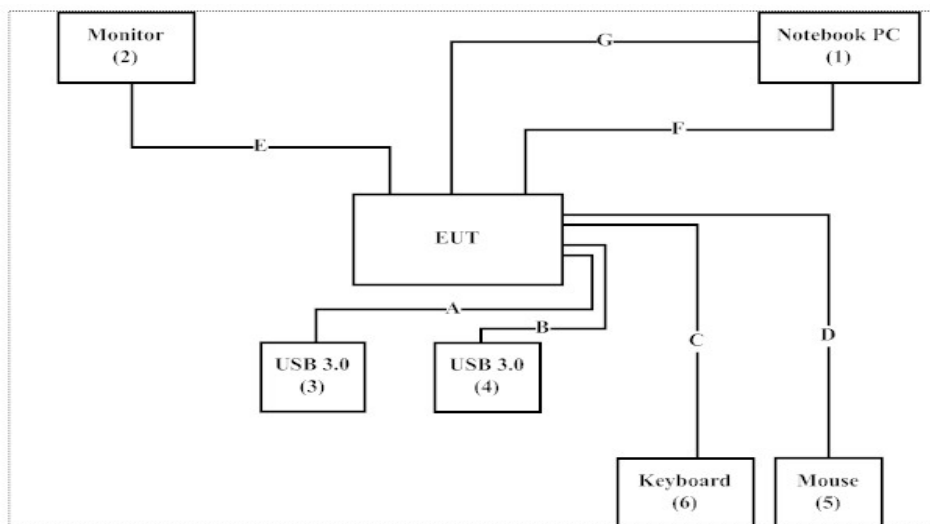

### 1.5. EUT Exercise Software

1. Setup the EUT as shown in Section 1.4.
2. Execute software “Ant RF Test App (Ver 1.00.00)” on the EUT.
3. Configure the test mode, the test channel, and the data rate.
4. Press “OK” to start the continuous Transmit.
5. Verify that the EUT works properly.

## 1.6. Test Facility

Ambient conditions in the laboratory:

Items	Required (IEC 68-1)	Actual
Temperature (°C)	15-35	20-35
Humidity (%RH)	25-75	50-65
Barometric pressure (mbar)	860-1060	950-1000

The related certificate for our laboratories about the test site and management system can be downloaded from DEKRA Testing and Certification Co., Ltd. Web Site:

<http://www.dekra.com.tw/english/about/certificates.aspx?bval=5>

The address and introduction of DEKRA Testing and Certification Co., Ltd. laboratories can be founded in our Web site: [http://www.dekra.com.tw/index\\_en](http://www.dekra.com.tw/index_en)

Site Description: Accredited by TAF  
Accredited Number: 3023

Site Name: DEKRA Testing and Certification Co., Ltd.  
Site Address: No.159, Sec. 2, Wenhua 1st Rd., Linkou Dist.,  
New Taipei City 24457, Taiwan.  
TEL: 886-2-2602-7968 / FAX : 866-2-2602-3286  
E-Mail : [info.tw@dekra.com](mailto:info.tw@dekra.com)

FCC Accreditation Number: TW3023



## 1.7. List of Test Equipment

### For Conduction measurements /ASR1

	Equipment	Manufacturer	Model No.	Serial No.	Cali. Data	Due. Data
X	EMI Test Receiver	R&S	ESR7	161601	2017.01.06	2018.01.05
X	Two-Line V-Network	R&S	ENV216	101306	2017.02.16	2018.02.15
X	Two-Line V-Network	R&S	ENV216	101307	2017.03.17	2018.03.16
X	Coaxial Cable	Quietek	RG400_BNC	RF001	2017.05.24	2018.05.23

Note:

1. All equipments are calibrated every one year.
2. The test instruments marked with "X" are used to measure the final test results.
3. Test Software version : QuieTek EMI 2.0 V2.1.113

### For Conducted measurements /ASR4

	Equipment	Manufacturer	Model No.	Serial No.	Cali. Data	Due. Data
X	Spectrum Analyzer	R&S	FSV30	103464	2017.01.09	2018.01.08
X	Power Meter	Anritsu	ML2496A	1548003	2016.12.15	2017.12.14
X	Power Sensor	Anritsu	MA2411B	1531024	2016.12.15	2017.12.14
X	Power Sensor	Anritsu	MA2411B	1531025	2016.12.15	2017.12.14
	Bluetooth Tester	R&S	CBT	101238	2017.01.03	2018.01.02

Note:

1. All equipments are calibrated every one year.
2. The test instruments marked with "X" are used to measure the final test results.
3. Test Software version : QuieTek Conduction Test System V8.0.110

### For Radiated measurements /ACB1

	Equipment	Manufacturer	Model No.	Serial No.	Cali. Data	Due. Data
X	Loop Antenna	TESEQ	HLA6121	37133	2016.03.18	2018.03.17
X	Bi-Log Antenna	SCHWARZBECK	VULB9168	9168-674	2017.02.09	2018.02.08
X	Horn Antenna	ETS-Lindgren	3117	00203800	2016.10.13	2017.10.12
X	Horn Antenna	Com-Power	AH-840	101087	2017.05.24	2018.05.23
X	Pre-Amplifier	EMCI	EMC001330	980316	2017.05.14	2018.05.13
X	Pre-Amplifier	EMCI	EMC051835SE	980311	2017.05.15	2018.05.14
X	Pre-Amplifier	EMCI	EMC05820SE	980310	2017.05.15	2018.05.14
X	Pre-Amplifier	EMCI	EMC184045SE	980314	2017.05.17	2018.05.16
X	Filter	MICRO TRONICS	BRM50702	G249	2017.08.11	2018.08.10
	Filter	MICRO TRONICS	BRM50716	G187	2017.08.16	2018.08.15
X	EMI Test Receiver	R&S	ESR7	101602	2016.12.15	2017.12.14
X	Spectrum Analyzer	R&S	FSV40	101148	2017.01.24	2018.01.23
X	Coaxial Cable	SUHNER	SUCOFLEX 106	RF002	2017.05.25	2018.05.24
X	Mircoflex Cable	HUBER SUHNER	SUCOFLEX 102	MY3381/2	2017.08.11	2018.08.10

Note:

1. Loop Antenna is calibrated every two year, the other equipments are calibrated every one year.
2. The test instruments marked with "X" are used to measure the final test results.
3. Test Software version : QuieTek EMI 2.0 V2.1.113

## 2. Conducted Emission

### 2.1. Test Setup

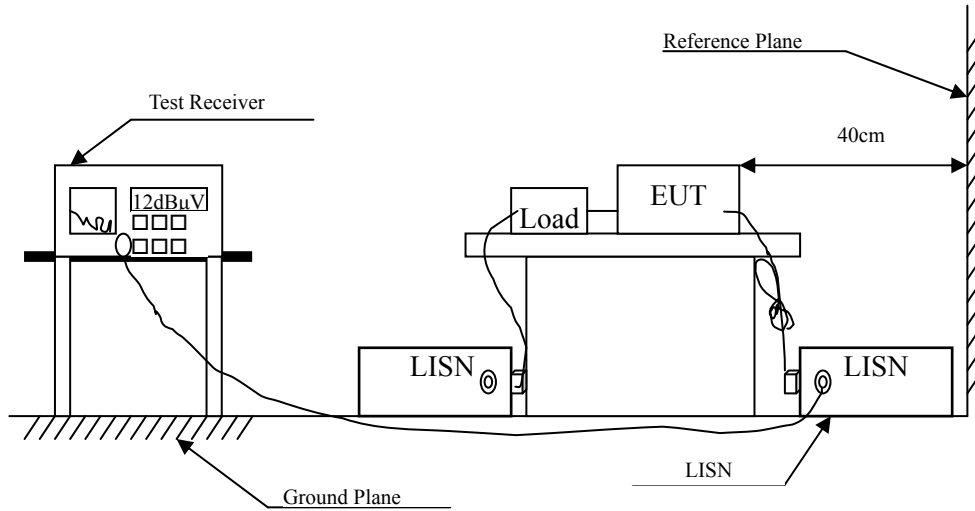

### 2.2. Limits

FCC Part 15 Subpart C Paragraph 15.207 (dB $\mu$ V) Limit		
Frequency MHz	Limits	
	QP	AV
0.15 - 0.50	66-56	56-46
0.50-5.0	56	46
5.0 - 30	60	50

Remarks: In the above table, the tighter limit applies at the band edges.

### **2.3. Test Procedure**

The EUT and Peripherals are connected to the main power through a line impedance stabilization network (L.I.S.N.). This provides a 50 ohm /50uH coupling impedance for the measuring equipment. The peripheral devices are also connected to the main power through a LISN that provides a 50ohm /50uH coupling impedance with 50ohm termination. (Please refer to the block diagram of the test setup and photographs.)

Both sides of A.C. line are checked for maximum conducted interference. In order to find the maximum emission, the relative positions of equipment and all the interface cables must be changed according to ANSI C63.4: 2014 on conducted measurement.

Conducted emissions were investigated over the frequency range from 0.15MHz to 30MHz using a receiver bandwidth of 9kHz.

The EUT was setup to ANSI C63.4, 2014; tested to FHSS test procedure of FCC Public Notice DA 00-705 for compliance to FCC 47CFR 15.247 requirements.

### **2.4. Uncertainty**

±2.35dB

## 2.5. Test Result of Conducted Emission

Product : Fanless Medical Grade Box PC  
 Test Item : Conducted Emission Test  
 Power Line : Line 1  
 Test Mode : Mode 2: Transmit - 3Mbps (2441MHz)\_ Adapter: ATM020-W050U  
 Test Date : 2017/10/02

Frequency MHz	Correct Factor dB	Reading Level dB $\mu$ V	Measurement Level dB $\mu$ V	Margin dB	Limit dB $\mu$ V
<b>LINE 1</b>					
<b>Quasi-Peak</b>					
0.153	9.561	39.270	48.830	-17.084	65.914
0.170	9.560	36.846	46.406	-19.023	65.429
0.604	9.580	36.013	45.593	-10.407	56.000
2.300	9.583	34.453	44.036	-11.964	56.000
2.663	9.587	29.140	38.727	-17.273	56.000
2.974	9.590	27.963	37.553	-18.447	56.000
<b>Average</b>					
0.153	9.561	27.418	36.978	-18.936	55.914
0.170	9.560	25.415	34.975	-20.454	55.429
0.604	9.580	28.034	37.614	-8.386	46.000
2.300	9.583	27.482	37.065	-8.935	46.000
2.663	9.587	23.999	33.586	-12.414	46.000
2.974	9.590	21.229	30.819	-15.181	46.000

### Note:

1. All Reading Levels are Quasi-Peak and average value.
2. "■" means the worst emission level.
3. Measurement Level = Reading Level + Correct Factor

Product : Fanless Medical Grade Box PC  
 Test Item : Conducted Emission Test  
 Power Line : Line 2  
 Test Mode : Mode 2: Transmit - 3Mbps (2441MHz) \_ Adapter: ATM020-W050U  
 Test Date : 2017/10/02

Frequency MHz	Correct Factor dB	Reading Level dB $\mu$ V	Measurement Level dB $\mu$ V	Margin dB	Limit dB $\mu$ V
<b>LINE 2</b>					
<b>Quasi-Peak</b>					
0.157	9.552	38.290	47.841	-17.959	65.800
0.206	9.560	32.048	41.607	-22.793	64.400
0.600	9.575	33.795	43.369	-12.631	56.000
2.300	9.583	34.008	43.591	-12.409	56.000
2.672	9.587	29.148	38.735	-17.265	56.000
2.976	9.590	27.717	37.307	-18.693	56.000
<b>Average</b>					
0.157	9.552	25.307	34.859	-20.941	55.800
0.206	9.560	20.952	30.511	-23.889	54.400
0.600	9.575	25.303	34.877	-11.123	46.000
2.300	9.583	28.063	37.646	-8.354	46.000
2.672	9.587	23.382	32.969	-13.031	46.000
2.976	9.590	20.911	30.501	-15.499	46.000

Note:

1. All Reading Levels are Quasi-Peak and average value.
2. "■" means the worst emission level.
3. Measurement Level = Reading Level + Correct Factor

Product : Fanless Medical Grade Box PC  
 Test Item : Conducted Emission Test  
 Power Line : Line 1  
 Test Mode : Mode 2: Transmit - 3Mbps (2441MHz)\_ Adapter: ATM036T-A050  
 Test Date : 2017/10/02

Frequency MHz	Correct Factor dB	Reading Level dB $\mu$ V	Measurement Level dB $\mu$ V	Margin dB	Limit dB $\mu$ V
<b>LINE 1</b>					
<b>Quasi-Peak</b>					
0.160	9.560	26.483	36.043	-29.671	65.714
0.390	9.572	31.795	41.367	-17.776	59.143
2.346	9.583	37.242	46.825	-9.175	56.000
2.700	9.587	31.090	40.677	-15.323	56.000
3.000	9.590	28.070	37.660	-18.340	56.000
3.364	9.594	25.242	34.836	-21.164	56.000
<b>Average</b>					
0.160	9.560	18.525	28.085	-27.629	55.714
0.390	9.572	23.645	33.218	-15.925	49.143
2.346	9.583	30.058	39.641	-6.359	46.000
2.700	9.587	24.395	33.982	-12.018	46.000
3.000	9.590	21.858	31.448	-14.552	46.000
3.364	9.594	17.751	27.345	-18.655	46.000

Note:

1. All Reading Levels are Quasi-Peak and average value.
2. "■" means the worst emission level.
3. Measurement Level = Reading Level + Correct Factor

Product : Fanless Medical Grade Box PC  
 Test Item : Conducted Emission Test  
 Power Line : Line 2  
 Test Mode : Mode 2: Transmit - 3Mbps (2441MHz) \_ Adapter: ATM036T-A050  
 Test Date : 2017/10/02

Frequency MHz	Correct Factor dB	Reading Level dB $\mu$ V	Measurement Level dB $\mu$ V	Margin dB	Limit dB $\mu$ V
<b>LINE 2</b>					
<b>Quasi-Peak</b>					
0.157	9.552	31.003	40.555	-25.245	65.800
0.390	9.567	32.524	42.091	-17.052	59.143
2.340	9.583	36.043	45.626	-10.374	56.000
2.700	9.587	31.228	40.815	-15.185	56.000
2.979	9.590	29.266	38.856	-17.144	56.000
3.400	9.594	23.675	33.269	-22.731	56.000
<b>Average</b>					
0.157	9.552	20.295	29.847	-25.953	55.800
0.390	9.567	24.835	34.402	-14.741	49.143
2.340	9.583	29.596	39.179	-6.821	46.000
2.700	9.587	23.908	33.495	-12.505	46.000
2.979	9.590	22.408	31.998	-14.002	46.000
3.400	9.594	16.367	25.961	-20.039	46.000

Note:

1. All Reading Levels are Quasi-Peak and average value.
2. "■" means the worst emission level.
3. Measurement Level = Reading Level + Correct Factor

### 3. Peak Power Output

#### 3.1. Test Setup

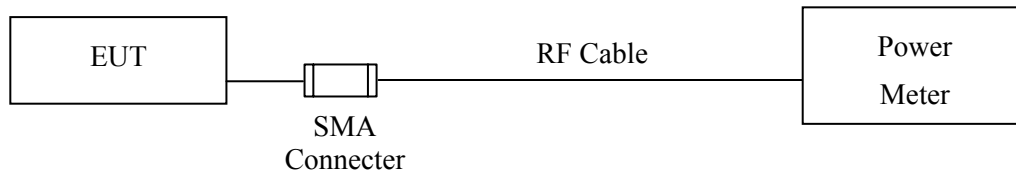

#### 3.2. Limit

The maximum peak power shall be less 1Watt.

#### 3.3. Test Procedure

The EUT was setup to ANSI C63.4, 2014; tested to FHSS test procedure of FCC Public Notice DA 00-705 for compliance to FCC 47CFR 15.247 requirements.

#### 3.4. Uncertainty

$\pm 0.86$  dB



### 3.5. Test Result of Peak Power Output

Product : Fanless Medical Grade Box PC  
Test Item : Peak Power Output  
Test Mode : Mode 1: Transmit - 1Mbps  
Test Date : 2017/09/20

Channel No.	Frequency (MHz)	Measurement (dBm)	Required Limit	Result
Channel 00	2402.00	5.32	1 Watt= 30 dBm	Pass
Channel 39	2441.00	6.37	1 Watt= 30 dBm	Pass
Channel 78	2480.00	6.52	1 Watt= 30 dBm	Pass

Product : Fanless Medical Grade Box PC  
Test Item : Peak Power Output  
Test Mode : Mode 2: Transmit - 3Mbps  
Test Date : 2017/09/20

Channel No.	Frequency (MHz)	Measurement (dBm)	Required Limit	Result
Channel 00	2402.00	3.84	1 Watt= 30 dBm	Pass
Channel 39	2441.00	5.21	1 Watt= 30 dBm	Pass
Channel 78	2480.00	5.44	1 Watt= 30 dBm	Pass

#### 4. Radiated Emission

##### 4.1. Test Setup

Radiated Emission Under 30MHz

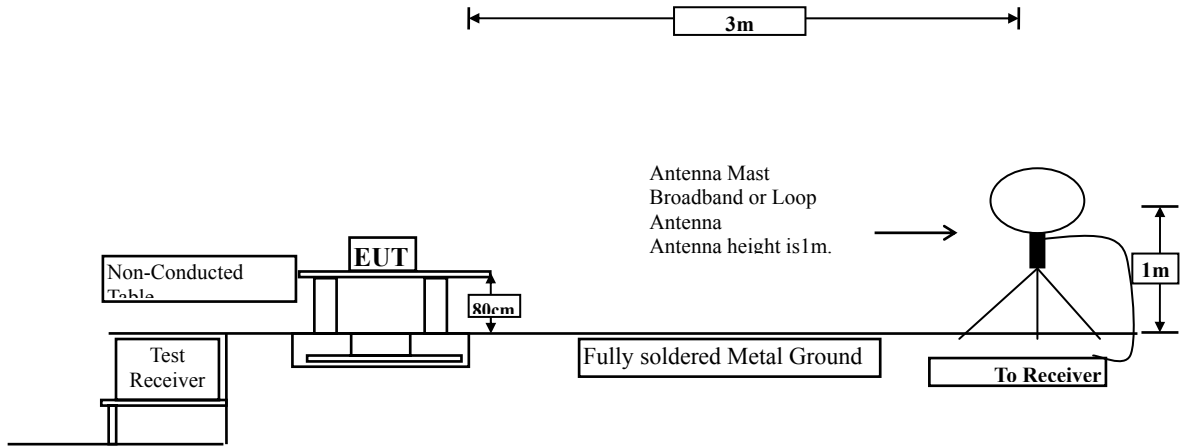

Radiated Emission Below 1GHz

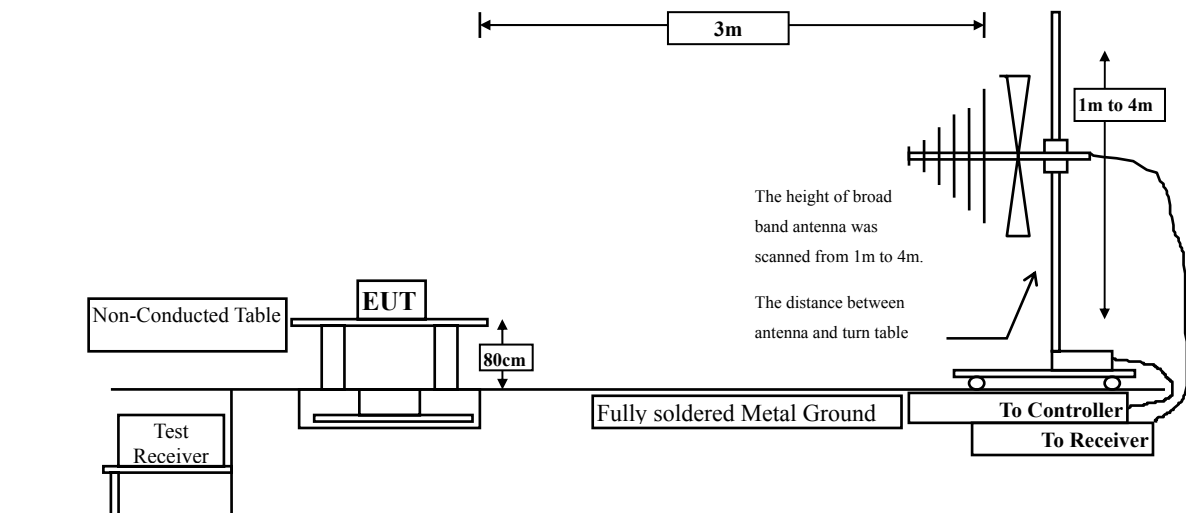

Radiated Emission Above 1GHz

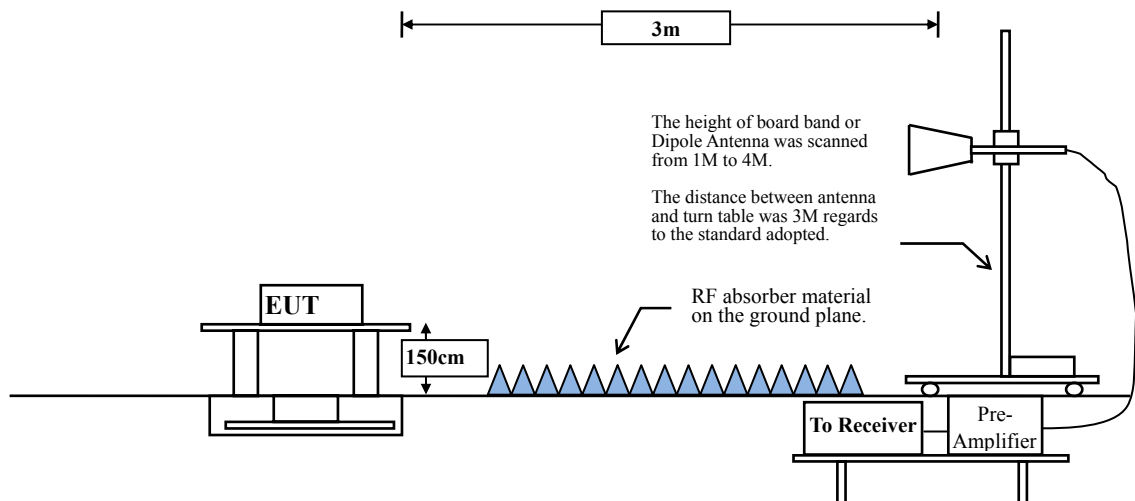

## 4.2. Limits

### ➤ General Radiated Emission Limits

Emissions radiated outside of the specified frequency bands, except for harmonics, shall be attenuated by at least 20dB below the level of the fundamental or to the general radiated emission limits in paragraph 15.209, whichever is the lesser attenuation.

<b>FCC Part 15 Subpart C Paragraph 15.209 Limits</b>		
Frequency MHz	Field strength (microvolts/meter)	Measurement distance (meter)
0.009-0.490	2400/F(kHz)	300
0.490-1.705	24000/F(kHz)	30
1.705-30	30	30
30-88	100	3
88-216	150	3
216-960	200	3
Above 960	500	3

- Remarks:
1. RF Voltage (dBuV) = 20 log RF Voltage (uV)
  2. In the Above Table, the tighter limit applies at the band edges.
  3. Distance refers to the distance in meters between the measuring instrument antenna and the closed point of any part of the device or system.

### 4.3. Test Procedure

The EUT was setup according to ANSI C63.10, 2013 and tested compliance to FCC 47CFR 15.247 requirements.

Measuring the frequency range below 1GHz, the EUT is placed on a turn table which is 0.8 meter above ground, when measuring the frequency range above 1GHz, the EUT is placed on a turn table which is 1.5 meter above ground.

The turn table is rotated 360 degrees to determine the position of the maximum emission level.

The EUT was positioned such that the distance from antenna to the EUT was 3 meters.

The antenna is scanned between 1 meter and 4 meters to find out the maximum emission level. This is repeated for both horizontal and vertical polarization of the antenna. In order to find the maximum emission, all of the interface cables were manipulated according to ANSI C63.10: 2013 on radiated measurement.

The resolution bandwidth below 30MHz setting on the field strength meter is 9kHz and 30MHz~1GHz is 120kHz and above 1GHz is 1MHz.

Radiated emission measurements below 30MHz are made using Loop Antenna and 30MHz~1GHz are made using broadband Bilog antenna and above 1GHz are made using Horn Antennas.

The measurement is divided into the Preliminary Measurement and the Final Measurement.

The suspected frequencies are searched for in Preliminary Measurement with the measurement antenna kept pointed at the source of the emission both in azimuth and elevation, with the polarization of the antenna oriented for maximum response. The antenna is pointed at an angle towards the source of the emission, and the EUT is rotated in both height and polarization to maximize the measured emission. The emission is kept within the illumination area of the 3 dB bandwidth of the antenna.

The measurement frequency range from 9kHz - 10th Harmonic of fundamental was investigated.

### 4.4. Uncertainty

Horizontal polarization :

30-300MHz:  $\pm 4.08$ dB ; 300M-1GHz:  $\pm 3.86$ dB ; 1-18GHz:  $\pm 3.77$ dB ; 18-40GHz:  $\pm 3.98$ dB

Vertical polarization :

30-300MHz:  $\pm 4.81$ dB ; 300M-1GHz:  $\pm 3.87$ dB ; 1-18GHz :  $\pm 3.83$ dB ; 18-40GHz:  $\pm 3.98$ dB

#### 4.5. Test Result of Radiated Emission

Product : Fanless Medical Grade Box PC  
 Test Item : Harmonic Radiated Emission  
 Test Mode : Mode 1: Transmit - 1Mbps(2402MHz)\_Adapter: ATM020-W050U  
 Test Date : 2017/09/13

Frequency MHz	Correct Factor dB	Reading Level dB $\mu$ V	Measurement Level dB $\mu$ V/m	Margin dB	Limit dB $\mu$ V/m
<b>Horizontal</b>					
<b>Peak Detector:</b>					
4804.000	-2.875	54.850	51.976	-22.024	74.000
7206.000	2.220	47.890	50.110	-23.890	74.000
9608.000	2.220	43.690	45.910	-28.090	74.000
<b>Average Detector:</b>					
--					54.000
<b>Vertical</b>					
<b>Peak Detector:</b>					
4804.000	-2.875	54.230	51.356	-22.644	74.000
7206.000	0.384	47.930	48.314	-25.686	74.000
9608.000	2.338	43.460	45.798	-28.202	74.000
<b>Average Detector:</b>					
--					54.000

Note:

1. All Readings below 1GHz are Quasi-Peak, above 1GHz are performed with peak and/or average measurements as necessary.
2. Peak measurements: RBW = 1MHz, VBW = 3 MHz, Sweep: Auto.
3. Average measurements: RBW = 1MHz, VBW = 10 Hz, Sweep: Auto.
4. Measurement Level = Reading Level + Correct Factor.
5. Correct Factor = Antenna factor + Cable loss – Amplifier gain.
6. The average measurement was not performed when the peak measured data under the limit of average detection.
7. The emission levels of other frequencies are very lower than the limit and not show in test report.

Product : Fanless Medical Grade Box PC  
 Test Item : Harmonic Radiated Emission  
 Test Mode : Mode 1: Transmit - 1Mbps(2441MHz)\_Adapter: ATM020-W050U  
 Test Date : 2017/09/13

Frequency MHz	Correct Factor dB	Reading Level dB $\mu$ V	Measurement Level dB $\mu$ V/m	Margin dB	Limit dB $\mu$ V/m
<b>Horizontal</b>					
<b>Peak Detector:</b>					
4882.000	-2.812	52.100	49.288	-24.712	74.000
7323.000	0.464	48.160	48.624	-25.376	74.000
9764.000	2.615	44.000	46.614	-27.386	74.000
<b>Average Detector:</b>					
--					54.000
<b>Vertical</b>					
<b>Peak Detector:</b>					
4882.000	-2.812	56.670	53.858	-20.142	74.000
7323.000	0.464	49.210	49.674	-24.326	74.000
9764.000	2.615	44.080	46.694	-27.306	74.000
<b>Average Detector:</b>					
--					54.000

Note:

1. All Readings below 1GHz are Quasi-Peak, above 1GHz are performed with peak and/or average measurements as necessary.
2. Peak measurements: RBW = 1MHz, VBW = 3 MHz, Sweep: Auto.
3. Average measurements: RBW = 1MHz, VBW = 10 Hz, Sweep: Auto.
4. Measurement Level = Reading Level + Correct Factor.
5. Correct Factor = Antenna factor + Cable loss – Amplifier gain.
6. The average measurement was not performed when the peak measured data under the limit of average detection.
7. The emission levels of other frequencies are very lower than the limit and not show in test report.

Product : Fanless Medical Grade Box PC  
 Test Item : Harmonic Radiated Emission  
 Test Mode : Mode 1: Transmit - 1Mbps(2480MHz)\_Adapter: ATM020-W050U  
 Test Date : 2017/09/13

Frequency MHz	Correct Factor dB	Reading Level dB $\mu$ V	Measurement Level dB $\mu$ V/m	Margin dB	Limit dB $\mu$ V/m
<b>Horizontal</b>					
<b>Peak Detector:</b>					
4960.000	-2.791	53.670	50.879	-23.121	74.000
7440.000	0.499	48.350	48.849	-25.151	74.000
9920.000	2.917	43.040	45.957	-28.043	74.000
<b>Average Detector:</b>					
--					54.000
<b>Vertical</b>					
<b>Peak Detector:</b>					
4960.000	-2.791	55.500	52.709	-21.291	74.000
7440.000	0.499	49.680	50.179	-23.821	74.000
9920.000	2.917	43.050	45.967	-28.033	74.000
<b>Average Detector:</b>					
--					54.000

## Note:

1. All Readings below 1GHz are Quasi-Peak, above 1GHz are performed with peak and/or average measurements as necessary.
2. Peak measurements: RBW = 1MHz, VBW = 3 MHz, Sweep: Auto.
3. Average measurements: RBW = 1MHz, VBW = 10 Hz, Sweep: Auto.
4. Measurement Level = Reading Level + Correct Factor.
5. Correct Factor = Antenna factor + Cable loss – Amplifier gain.
6. The average measurement was not performed when the peak measured data under the limit of average detection.
7. The emission levels of other frequencies are very lower than the limit and not show in test report.



Product : Fanless Medical Grade Box PC  
 Test Item : Harmonic Radiated Emission  
 Test Mode : Mode 2: Transmit - 3Mbps(2402MHz)\_Adapter: ATM020-W050U  
 Test Date : 2017/09/13

Frequency MHz	Correct Factor dB	Reading Level dBμV	Measurement Level dBμV/m	Margin dB	Limit dBμV/m
<b>Horizontal</b>					
<b>Peak Detector:</b>					
4804.000	-2.875	47.530	44.656	-29.344	74.000
7206.000	0.384	44.090	44.474	-29.526	74.000
9608.000	2.338	43.410	45.748	-28.252	74.000
<b>Average Detector:</b>					
--					54.000
<b>Vertical</b>					
<b>Peak Detector:</b>					
4804.000	-2.875	49.760	46.886	-27.114	74.000
7206.000	0.384	45.020	45.404	-28.596	74.000
9608.000	2.338	43.470	45.808	-28.192	74.000
<b>Average Detector:</b>					
--					54.000

Note:

1. All Readings below 1GHz are Quasi-Peak, above 1GHz are performed with peak and/or average measurements as necessary.
2. Peak measurements: RBW = 1MHz, VBW = 3 MHz, Sweep: Auto.
3. Average measurements: RBW = 1MHz, VBW = 10 Hz, Sweep: Auto.
4. Measurement Level = Reading Level + Correct Factor.
5. Correct Factor = Antenna factor + Cable loss – Amplifier gain.
6. The average measurement was not performed when the peak measured data under the limit of average detection.
7. The emission levels of other frequencies are very lower than the limit and not show in test report.

Product : Fanless Medical Grade Box PC  
 Test Item : Harmonic Radiated Emission  
 Test Mode : Mode 2: Transmit - 3Mbps (2441MHz)\_Adapter: ATM020-W050U  
 Test Date : 2017/09/13

Frequency MHz	Correct Factor dB	Reading Level dBµV	Measurement Level dBµV/m	Margin dB	Limit dBµV/m
<b>Horizontal</b>					
<b>Peak Detector:</b>					
4882.000	-2.812	49.940	47.128	-26.872	74.000
7323.000	0.464	44.560	45.024	-28.976	74.000
9764.000	2.615	44.220	46.834	-27.166	74.000
<b>Average Detector:</b>					
--					54.000
<b>Vertical</b>					
<b>Peak Detector:</b>					
4882.000	-2.812	53.630	50.818	-23.182	74.000
7323.000	0.464	45.250	45.714	-28.286	74.000
9764.000	2.615	44.220	46.834	-27.166	74.000
<b>Average Detector:</b>					
--					54.000

Note:

1. All Readings below 1GHz are Quasi-Peak, above 1GHz are performed with peak and/or average measurements as necessary.
2. Peak measurements: RBW = 1MHz, VBW = 3 MHz, Sweep: Auto.
3. Average measurements: RBW = 1MHz, VBW = 10 Hz, Sweep: Auto.
4. Measurement Level = Reading Level + Correct Factor.
5. Correct Factor = Antenna factor + Cable loss – Amplifier gain.
6. The average measurement was not performed when the peak measured data under the limit of average detection.
7. The emission levels of other frequencies are very lower than the limit and not show in test report.

Product : Fanless Medical Grade Box PC  
 Test Item : Harmonic Radiated Emission  
 Test Mode : Mode 2: Transmit - 3Mbps (2480MHz)\_Adapter: ATM020-W050U  
 Test Date : 2017/09/13

Frequency MHz	Correct Factor dB	Reading Level dB $\mu$ V	Measurement Level dB $\mu$ V/m	Margin dB	Limit dB $\mu$ V/m
<b>Horizontal</b>					
<b>Peak Detector:</b>					
4960.000	-2.791	51.010	48.219	-25.781	74.000
7440.000	0.499	44.510	45.009	-28.991	74.000
9920.000	2.917	42.710	45.627	-28.373	74.000
<b>Average Detector:</b>					
--					54.000
<b>Vertical</b>					
<b>Peak Detector:</b>					
4960.000	-2.791	53.790	50.999	-23.001	74.000
7440.000	0.499	45.810	46.309	-27.691	74.000
9920.000	2.917	42.600	45.517	-28.483	74.000
<b>Average Detector:</b>					
--					54.000

Note:

1. All Readings below 1GHz are Quasi-Peak, above 1GHz are performed with peak and/or average measurements as necessary.
2. Peak measurements: RBW = 1MHz, VBW = 3 MHz, Sweep: Auto.
3. Average measurements: RBW = 1MHz, VBW = 10 Hz, Sweep: Auto.
4. Measurement Level = Reading Level + Correct Factor.
5. Correct Factor = Antenna factor + Cable loss – Amplifier gain.
6. The average measurement was not performed when the peak measured data under the limit of average detection.
7. The emission levels of other frequencies are very lower than the limit and not show in test report.

Product : Fanless Medical Grade Box PC  
 Test Item : General Radiated Emission  
 Test Mode : Mode 1: Transmit - 1Mbps (2441MHz)\_Adapter: ATM020-W050U  
 Test Date : 2017/10/03

Frequency MHz	Correct Factor dB	Reading Level dB $\mu$ V	Measurement Level dB $\mu$ V/m	Margin dB	Limit dB $\mu$ V/m
<b>Horizontal</b>					
184.638	-12.729	53.027	40.299	-3.201	43.500
238.058	-11.986	53.586	41.600	-4.400	46.000
399.725	-7.349	49.744	42.395	-3.605	46.000
616.217	-2.930	41.036	38.106	-7.894	46.000
770.855	-0.656	45.401	44.744	-1.256	46.000
924.087	1.169	43.410	44.578	-1.422	46.000
<b>Vertical</b>					
38.435	-11.273	50.048	38.775	-1.225	40.000
186.043	-12.887	53.594	40.707	-2.793	43.500
399.725	-7.349	50.670	43.321	-2.679	46.000
533.275	-4.610	45.638	41.028	-4.972	46.000
770.855	-0.656	45.309	44.652	-1.348	46.000
924.087	1.169	43.689	44.857	-1.143	46.000

## Note:

1. All Readings below 1GHz are Quasi-Peak, above 1GHz are performed with peak and/or average measurements as necessary.
2. Peak measurements: RBW = 1MHz, VBW = 3 MHz, Sweep: Auto.
3. Average measurements: RBW = 1MHz, VBW = 10 Hz, Sweep: Auto.
4. Measurement Level = Reading Level + Correct Factor.
5. Correct Factor = Antenna factor + Cable loss – Amplifier gain.
6. The average measurement was not performed when the peak measured data under the limit of average detection.
7. The emission levels of other frequencies are very lower than the limit and not show in test report.
8. No emission found between lowest internal used/generated frequency to 30MHz.

Product : Fanless Medical Grade Box PC  
 Test Item : General Radiated Emission  
 Test Mode : Mode 2: Transmit - 3Mbps (2441MHz)\_Adapter: ATM020-W050U  
 Test Date : 2017/10/03

Frequency MHz	Correct Factor dB	Reading Level dB $\mu$ V	Measurement Level dB $\mu$ V/m	Margin dB	Limit dB $\mu$ V/m
<b>Horizontal</b>					
132.623	-11.694	46.604	34.910	-8.590	43.500
184.638	-12.729	52.419	39.691	-3.809	43.500
399.725	-7.349	50.219	42.870	-3.130	46.000
609.188	-2.989	37.637	34.648	-11.352	46.000
770.855	-0.656	39.092	38.435	-7.565	46.000
924.087	1.169	40.558	41.726	-4.274	46.000
<b>Vertical</b>					
30.000	-12.125	51.392	39.267	-0.733	40.000
181.826	-12.407	51.253	38.845	-4.655	43.500
399.725	-7.349	46.094	38.745	-7.255	46.000
533.275	-4.610	44.773	40.163	-5.837	46.000
616.217	-2.930	43.345	40.415	-5.585	46.000
924.087	1.169	43.715	44.883	-1.117	46.000

## Note:

1. All Readings below 1GHz are Quasi-Peak, above 1GHz are performed with peak and/or average measurements as necessary.
2. Peak measurements: RBW = 1MHz, VBW = 3 MHz, Sweep: Auto.
3. Average measurements: RBW = 1MHz, VBW = 10 Hz, Sweep: Auto.
4. Measurement Level = Reading Level + Correct Factor.
5. Correct Factor = Antenna factor + Cable loss – Amplifier gain.
6. The average measurement was not performed when the peak measured data under the limit of average detection.
7. The emission levels of other frequencies are very lower than the limit and not show in test report.
8. No emission found between lowest internal used/generated frequency to 30MHz.

Product : Fanless Medical Grade Box PC  
 Test Item : General Radiated Emission  
 Test Mode : Mode 1: Transmit - 1Mbps (2441MHz)\_Adapter: ATM036T-A050  
 Test Date : 2017/10/03

Frequency MHz	Correct Factor dB	Reading Level dB $\mu$ V	Measurement Level dB $\mu$ V/m	Margin dB	Limit dB $\mu$ V/m
<b>Horizontal</b>					
195.884	-13.430	55.409	41.979	-1.521	43.500
224.000	-12.636	57.415	44.779	-1.221	46.000
399.725	-7.349	51.667	44.318	-1.682	46.000
600.754	-3.062	39.409	36.347	-9.653	46.000
770.855	-0.656	43.926	43.269	-2.731	46.000
1000.000	2.220	42.458	44.678	-9.322	54.000
<b>Vertical</b>					
31.406	-12.007	51.786	39.779	-0.221	40.000
195.884	-13.430	53.174	39.744	-3.756	43.500
399.725	-7.349	45.065	37.716	-8.284	46.000
533.275	-4.610	45.314	40.704	-5.296	46.000
924.087	1.169	39.656	40.824	-5.176	46.000
1000.000	2.220	43.673	45.893	-8.107	54.000

## Note:

- All Readings below 1GHz are Quasi-Peak, above 1GHz are performed with peak and/or average measurements as necessary.
- Peak measurements: RBW = 1MHz, VBW = 3 MHz, Sweep: Auto.
- Average measurements: RBW = 1MHz, VBW = 10 Hz, Sweep: Auto.
- Measurement Level = Reading Level + Correct Factor.
- Correct Factor = Antenna factor + Cable loss – Amplifier gain.
- The average measurement was not performed when the peak measured data under the limit of average detection.
- The emission levels of other frequencies are very lower than the limit and not show in test report.
- No emission found between lowest internal used/generated frequency to 30MHz.

Product : Fanless Medical Grade Box PC  
 Test Item : General Radiated Emission  
 Test Mode : Mode 2: Transmit - 3Mbps (2441MHz)\_Adapter: ATM036T-A050  
 Test Date : 2017/10/03

Frequency MHz	Correct Factor dB	Reading Level dB $\mu$ V	Measurement Level dB $\mu$ V/m	Margin dB	Limit dB $\mu$ V/m
<b>Horizontal</b>					
194.478	-13.411	54.803	41.392	-2.108	43.500
399.725	-7.349	49.498	42.149	-3.851	46.000
600.754	-3.062	38.012	34.950	-11.050	46.000
770.855	-0.656	42.511	41.854	-4.146	46.000
924.087	1.169	42.905	44.073	-1.927	46.000
1000.000	2.220	41.901	44.121	-9.879	54.000
<b>Vertical</b>					
32.812	-11.890	51.710	39.820	-0.180	40.000
195.884	-13.430	53.350	39.920	-3.580	43.500
399.725	-7.349	48.159	40.810	-5.190	46.000
533.275	-4.610	44.721	40.111	-5.889	46.000
770.855	-0.656	43.577	42.920	-3.080	46.000
1000.000	2.220	44.371	46.591	-7.409	54.000

## Note:

1. All Readings below 1GHz are Quasi-Peak, above 1GHz are performed with peak and/or average measurements as necessary.
2. Peak measurements: RBW = 1MHz, VBW = 3 MHz, Sweep: Auto.
3. Average measurements: RBW = 1MHz, VBW = 10 Hz, Sweep: Auto.
4. Measurement Level = Reading Level + Correct Factor.
5. Correct Factor = Antenna factor + Cable loss – Amplifier gain.
6. The average measurement was not performed when the peak measured data under the limit of average detection.
7. The emission levels of other frequencies are very lower than the limit and not show in test report.
8. No emission found between lowest internal used/generated frequency to 30MHz.

## 5. RF Antenna Conducted Test

### 5.1. Test Setup

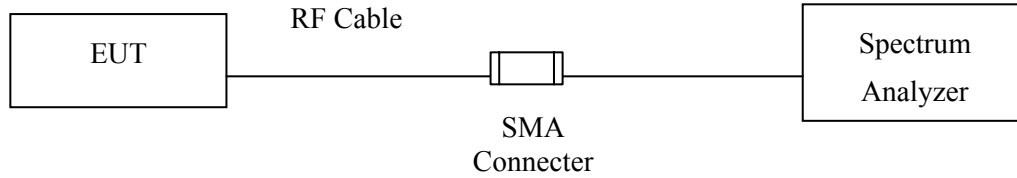

### 5.2. Limits

According to FCC Section 15.247(d). In any 100 kHz bandwidth outside the frequency band in which the spread spectrum or digitally modulated intentional radiator is operating, the radio frequency power that is produced by the intentional radiator shall be at least 20 dB below that in the 100 kHz bandwidth within the band that contains the highest level of the desired power, based on either an RF conducted or measurement, provided the transmitter demonstrates compliance with the peak conducted power limits. If the transmitter complies with the conducted power limits based on the use of RMS averaging over a time interval, the attenuation required under this paragraph shall be 30 dB instead of 20 dB.

### 5.3. Test Procedure

The EUT was setup to ANSI C63.4, 2014; tested to FHSS test procedure of FCC Public Notice DA 00-705 for compliance to FCC 47CFR 15.247 requirements.

### 5.4. Uncertainty

$\pm 1.23\text{dB}$



### 5.5. Test Result of RF Antenna Conducted Test

Product : Fanless Medical Grade Box PC  
 Test Item : RF Antenna Conducted Test  
 Test Mode : Mode 1: Transmit - 1Mbps  
 Test Date : 2017/09/16

**Figure Channel 00:**

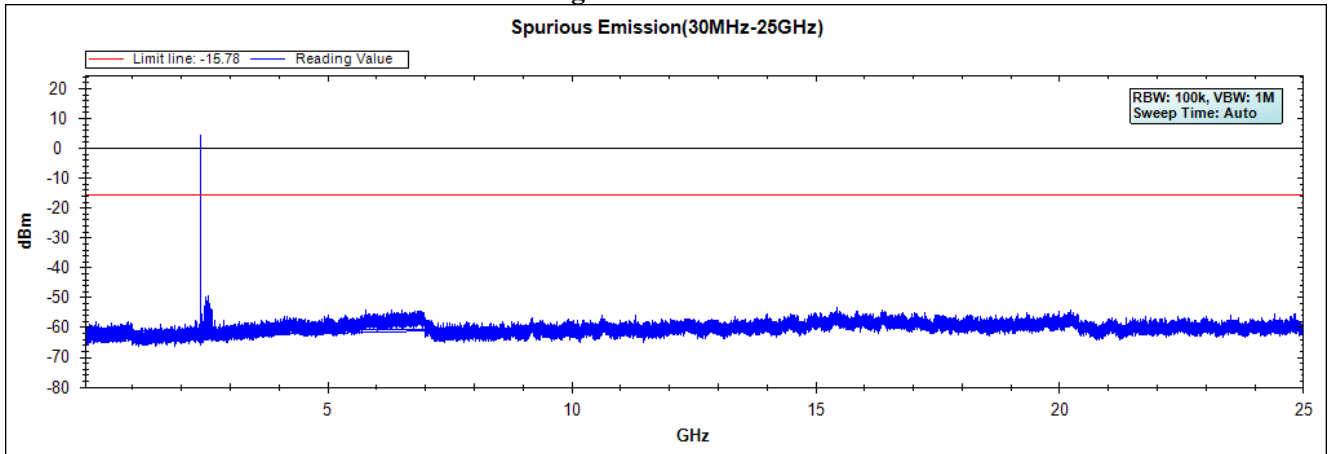

**Figure Channel 39:**

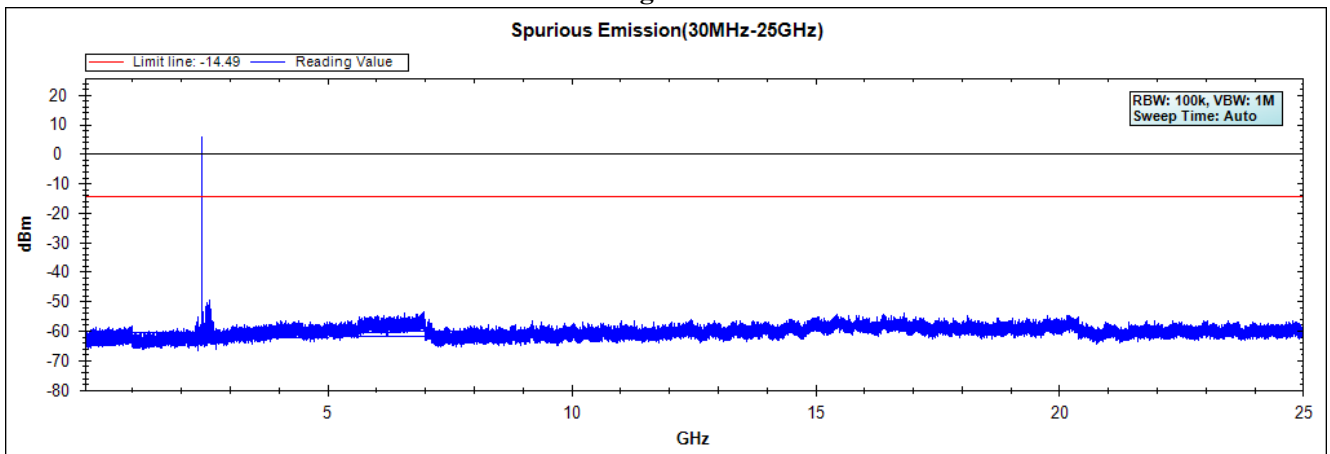

**Figure Channel 78:**

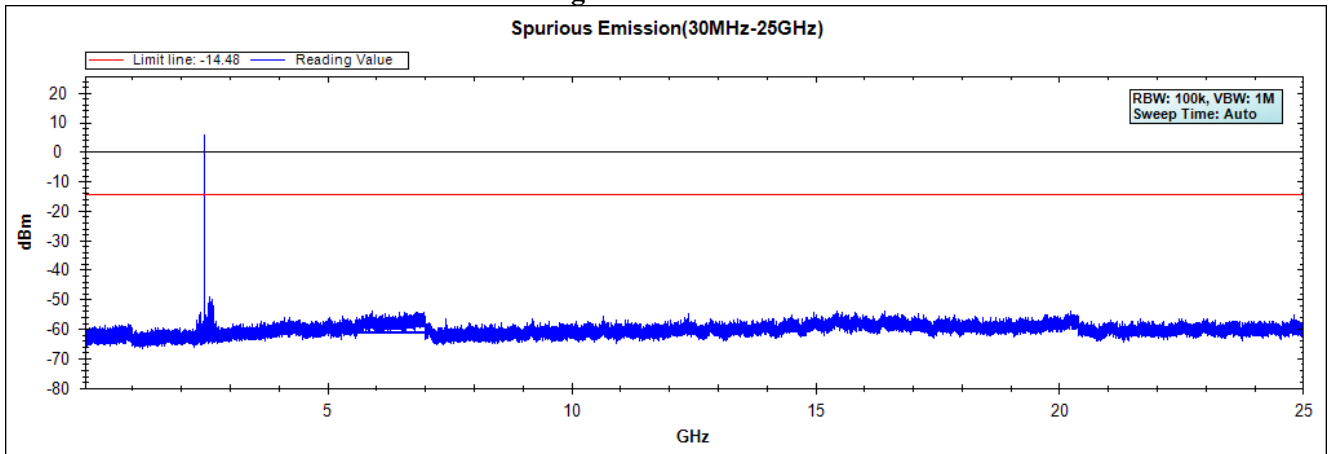

Note: The above test pattern is synthesized by multiple of the frequency range.

Product : Fanless Medical Grade Box PC  
Test Item : RF Antenna Conducted Test  
Test Mode : Mode 2: Transmit - 3Mbps  
Test Date : 2017/09/16

**Figure Channel 00:**

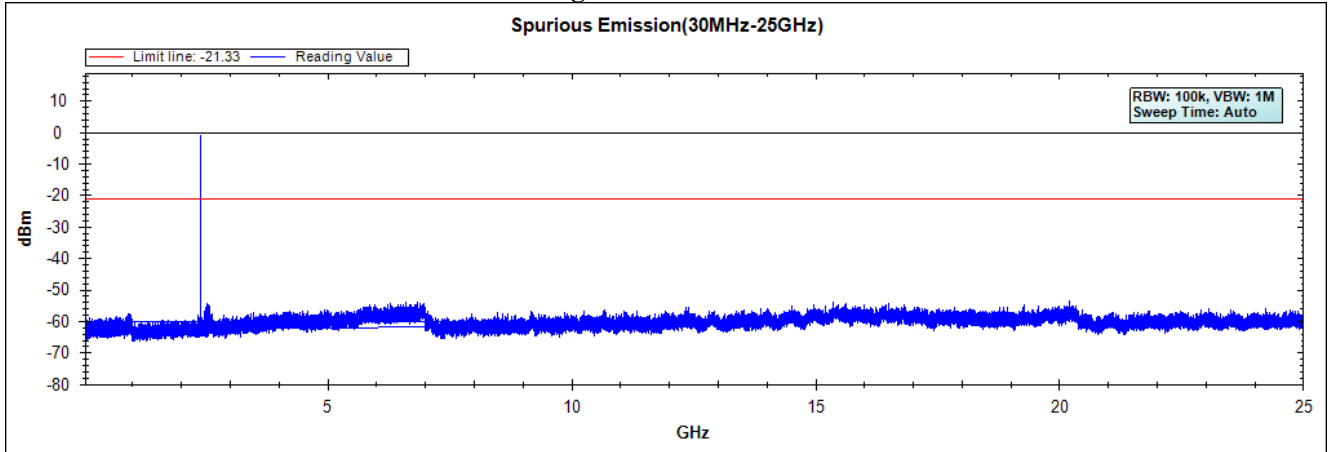

**Figure Channel 39:**

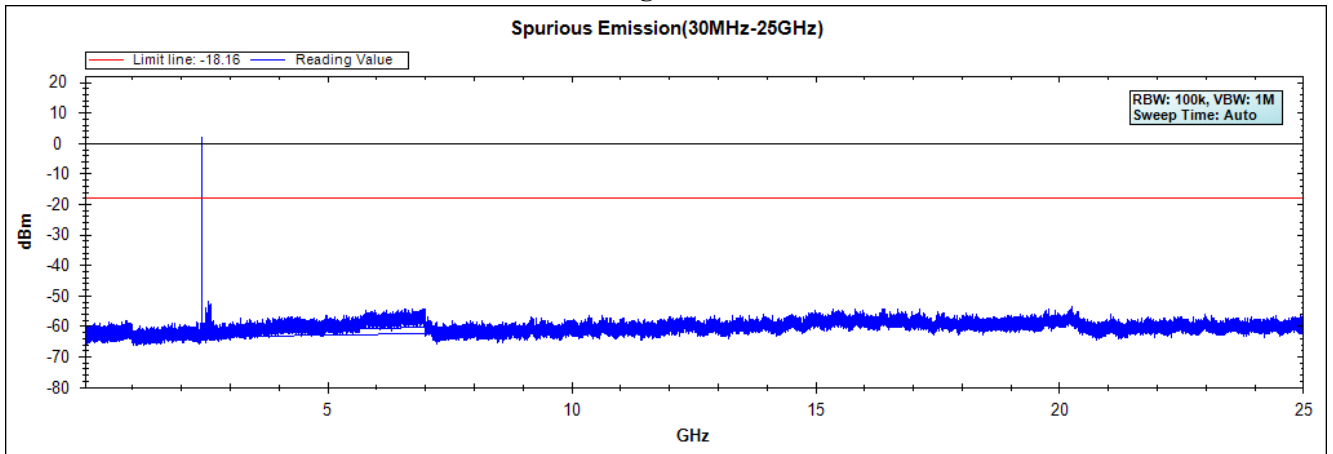

**Figure Channel 78:**

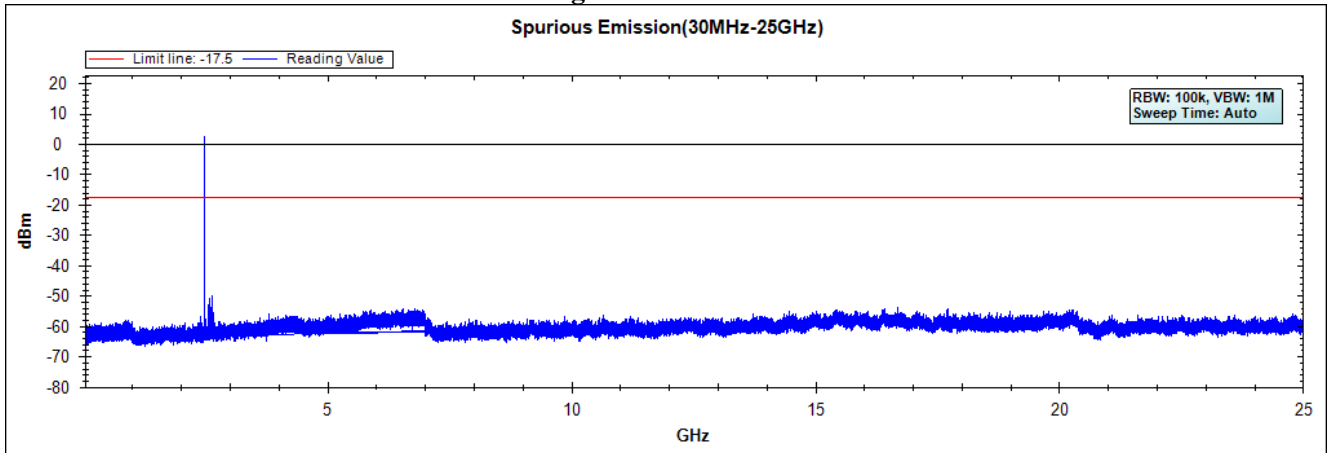

Note: The above test pattern is synthesized by multiple of the frequency range.

## 6. Band Edge

### 6.1. Test Setup

#### RF Conducted Measurement

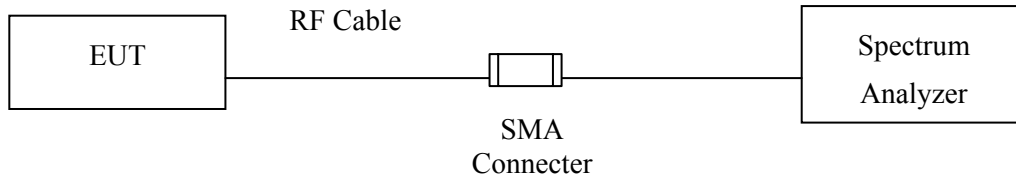

#### RF Radiated Measurement:

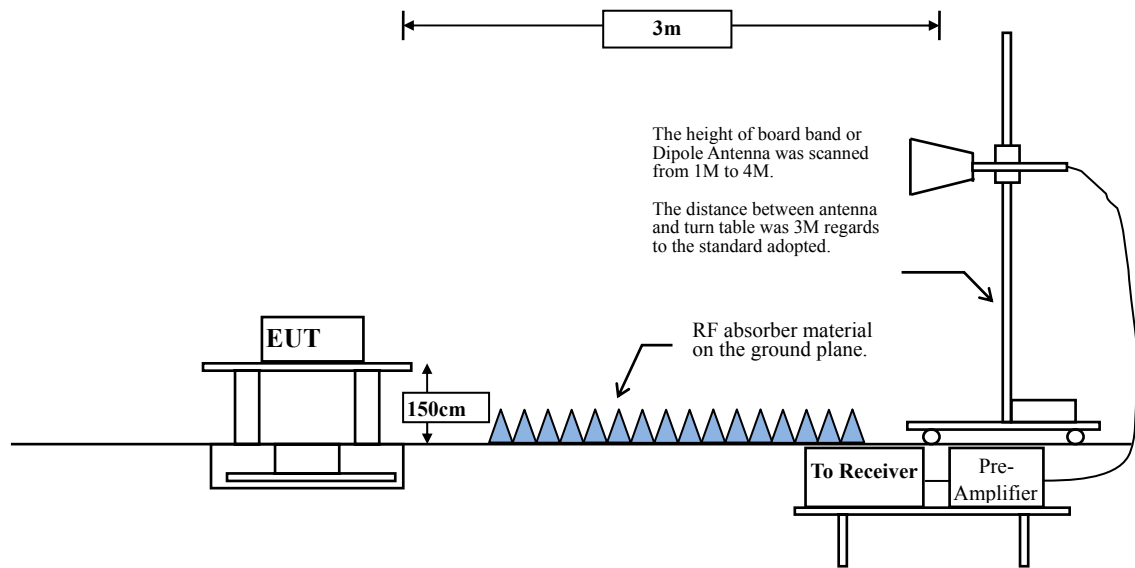

## 6.2. Limit

According to FCC Section 15.247(d). In any 100 kHz bandwidth outside the frequency band in which the spread spectrum or digitally modulated intentional radiator is operating, the radio frequency power that is produced by the intentional radiator shall be at least 20 dB below that in the 100 kHz bandwidth within the band that contains the highest level of the desired power, based on either an RF conducted or measurement, provided the transmitter demonstrates compliance with the peak conducted power limits. If the transmitter complies with the conducted power limits based on the use of RMS averaging over a time interval, the attenuation required under this paragraph shall be 30 dB instead of 20 dB. Attenuation below the general limits specified in Section 15.209(a) is not required. In addition, radiated emissions which fall in the restricted bands, as defined in Section 15.205(a), must also comply with the radiated emission limits specified in Section 15.209(a) (see Section 15.205(c)).

## 6.3. Test Procedure

The EUT is placed on a turn table which is 1.5 meter above ground. The turn table is rotated 360 degrees to determine the position of the maximum emission level. The EUT was positioned such that the distance from antenna to the EUT was 3 meters.

The antenna can move up and down between 1 meter and 4 meters to find out the maximum emission level.

Both horizontal and vertical polarization of the antenna are set on measurement. In order to find the maximum emission, all of the interface cables must be manipulated according to ANSI C63.10: 2013 on radiated measurement.

The bandwidth setting below 1GHz and above 1GHz on the field strength meter is 120 kHz and 1MHz, respectively.

## 6.4. Uncertainty

Conducted:  $\pm 1.23$ dB

Radiated:

Horizontal polarization : 1-18GHz:  $\pm 3.77$ dB

Vertical polarization : 1-18GHz :  $\pm 3.83$ dB

### 6.5. Test Result of Band Edge

Product : Fanless Medical Grade Box PC  
 Test Item : Band Edge  
 Test Mode : Mode 1: Transmit - 1Mbps (2402MHz)  
 Test Date : 2017/09/14

#### RF Radiated Measurement (Horizontal):

Channel No.	Frequency (MHz)	Correct Factor (dB)	Reading Level (dBμV)	Emission Level (dBμV/m)	Peak Limit (dBμV/m)	Average Limit (dBμV/m)	Result
00 (Peak)	2376.522	12.109	34.177	46.286	74.00	54.00	Pass
00 (Peak)	2390.000	12.148	30.562	42.710	74.00	54.00	Pass
00 (Peak)	2400.000	12.176	57.412	69.588	--	--	Pass
00 (Peak)	2402.174	12.182	93.064	105.246	--	--	--
00 (Average)	2375.942	12.108	23.429	35.537	74.00	54.00	Pass
00 (Average)	2390.000	12.148	16.825	28.973	74.00	54.00	Pass
00 (Average)	2400.000	12.176	40.604	52.780	--	--	Pass
00 (Average)	2402.029	12.182	76.613	88.794	--	--	--

Figure Channel 00: Horizontal (Peak)

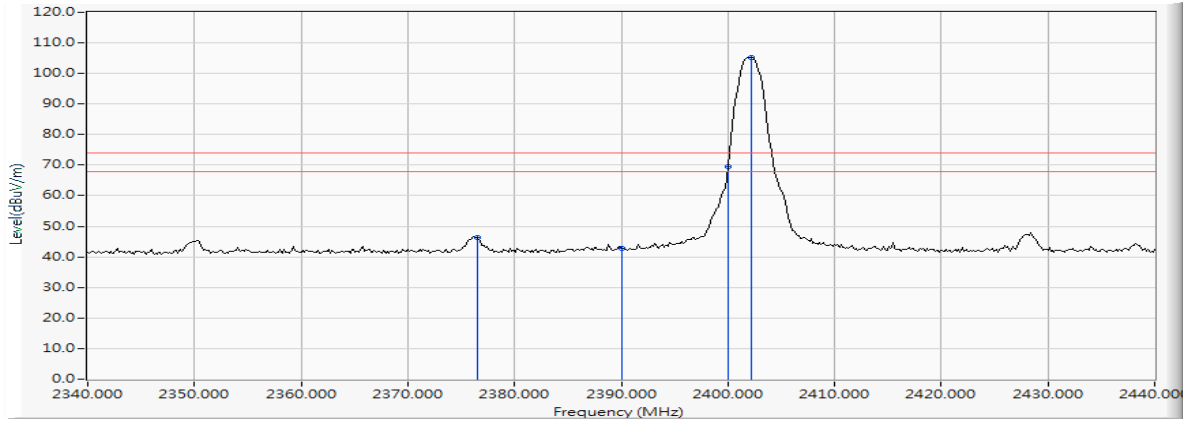
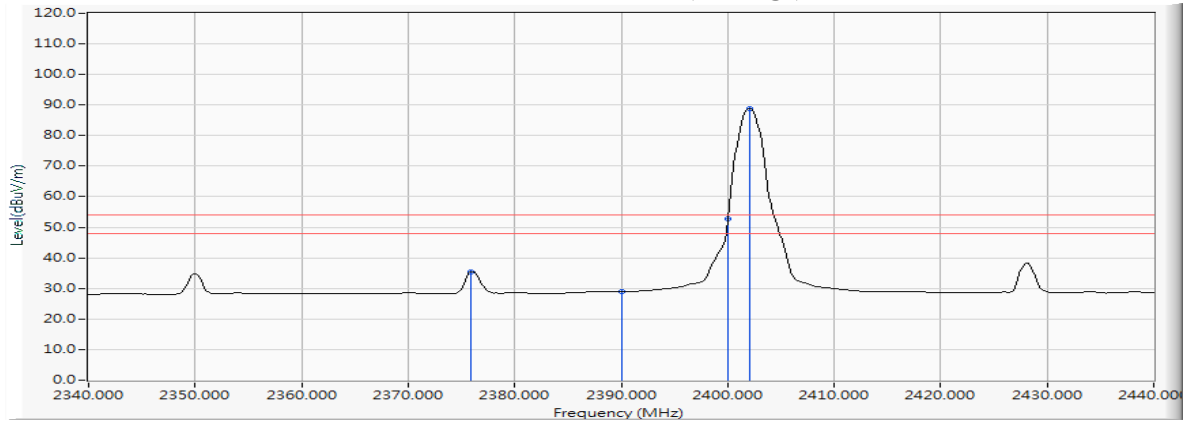

Figure Channel 00: Horizontal (Average)



Note:

1. All readings above 1GHz are performed with peak and/or average measurements as necessary.
2. Peak measurements: RBW = 1MHz, VBW = 3 MHz, Sweep: Auto.
3. Average measurements: RBW = 1MHz, VBW = 10 Hz, Sweep: Auto.
4. “ \* ” means this data is the worst emission level.
5. Measurement Level = Reading Level + Correction Factor.
6. The average measurement was not performed when the peak measured data is under the limit of average detection.

Product : Fanless Medical Grade Box PC  
 Test Item : Band Edge  
 Test Mode : Mode 1: Transmit - 1Mbps (2402MHz)  
 Test Date : 2017/09/14

**RF Radiated Measurement (VERTICAL):**

Channel No.	Frequency (MHz)	Correct Factor (dB)	Reading Level (dBμV)	Emission Level (dBμV/m)	Peak Limit (dBμV/m)	Average Limit (dBμV/m)	Result
00 (Peak)	2376.087	12.108	30.322	42.430	74.00	54.00	Pass
00 (Peak)	2390.000	12.148	29.242	41.390	74.00	54.00	Pass
00 (Peak)	2400.000	12.176	50.179	62.355	--	--	Pass
00 (Peak)	2402.174	12.182	86.170	98.352	--	--	--
00 (Average)	2376.087	12.108	17.710	29.818	74.00	54.00	Pass
00 (Average)	2390.000	12.148	15.902	28.050	74.00	54.00	Pass
00 (Average)	2400.000	12.176	35.127	47.303	--	--	Pass
00 (Average)	2402.029	12.182	71.215	83.396	--	--	--

**Figure Channel 00: VERTICAL (Peak)**

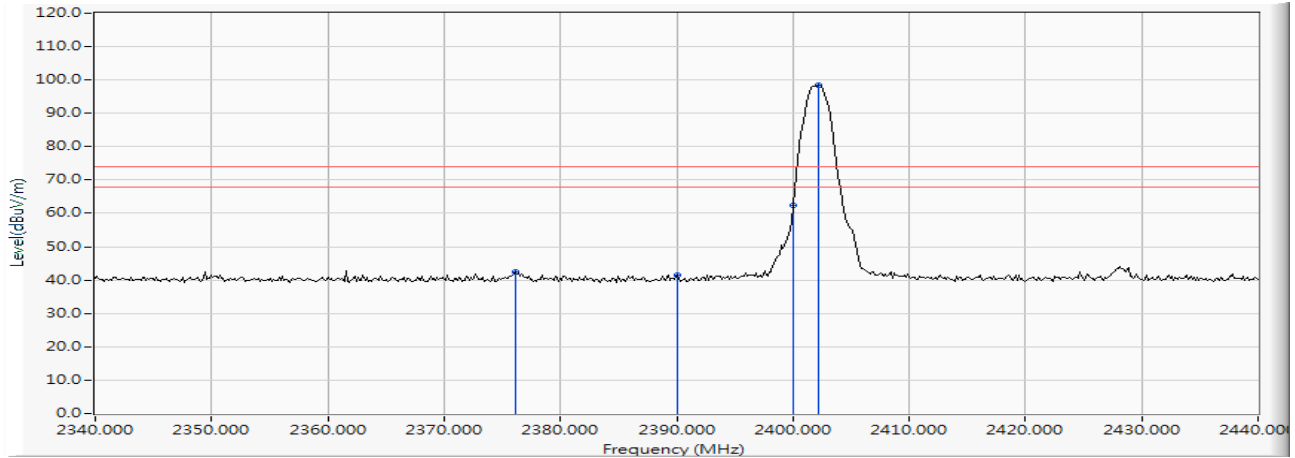

**Figure Channel 00: VERTICAL (Average)**

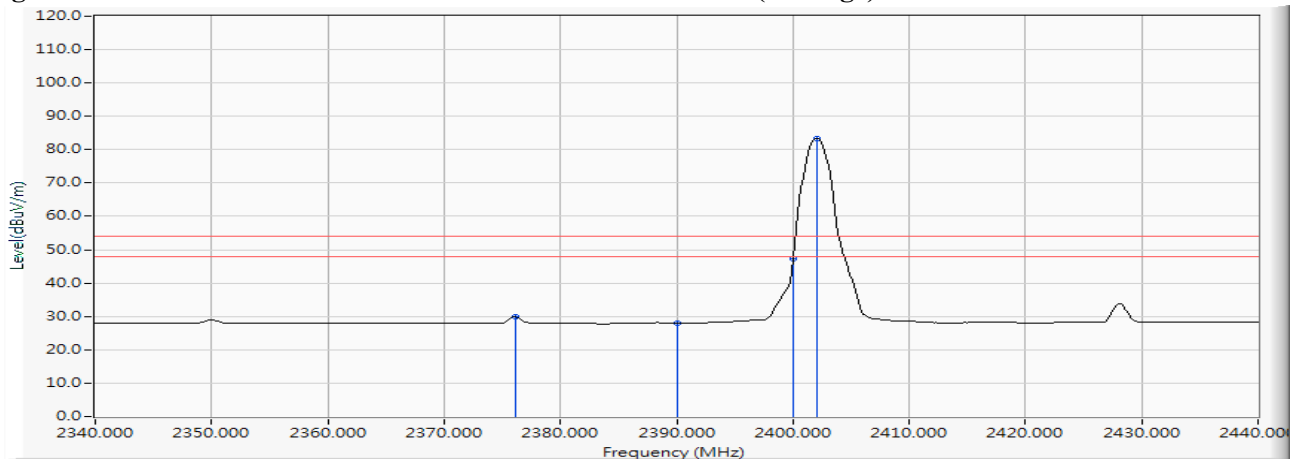

**Note:**

1. All readings above 1GHz are performed with peak and/or average measurements as necessary.
2. Peak measurements: RBW = 1MHz, VBW = 3 MHz, Sweep: Auto.
3. Average measurements: RBW = 1MHz, VBW = 10 Hz, Sweep: Auto.
4. “ \* ”, means this data is the worst emission level.
5. Measurement Level = Reading Level + Correction Factor.
6. The average measurement was not performed when the peak measured data is under the limit of average detection.

Product : Fanless Medical Grade Box PC  
 Test Item : Band Edge  
 Test Mode : Mode 1: Transmit - 1Mbps (2480MHz)  
 Test Date : 2017/09/14

**RF Radiated Measurement (Horizontal):**

Channel No.	Frequency (MHz)	Correct Factor (dB)	Reading Level (dBµV)	Emission Level (dBµV/m)	Peak Limit (dBµV/m)	Average Limit (dBµV/m)	Result
78 (Peak)	2479.877	12.393	93.449	105.842	--	--	--
78 (Peak)	2483.500	12.403	41.700	54.103	74.00	54.00	Pass
78 (Average)	2480.022	12.393	77.016	89.409	--	--	--
78 (Average)	2483.500	12.403	27.906	40.309	74.00	54.00	Pass

**Figure Channel 78: Horizontal (Peak)**

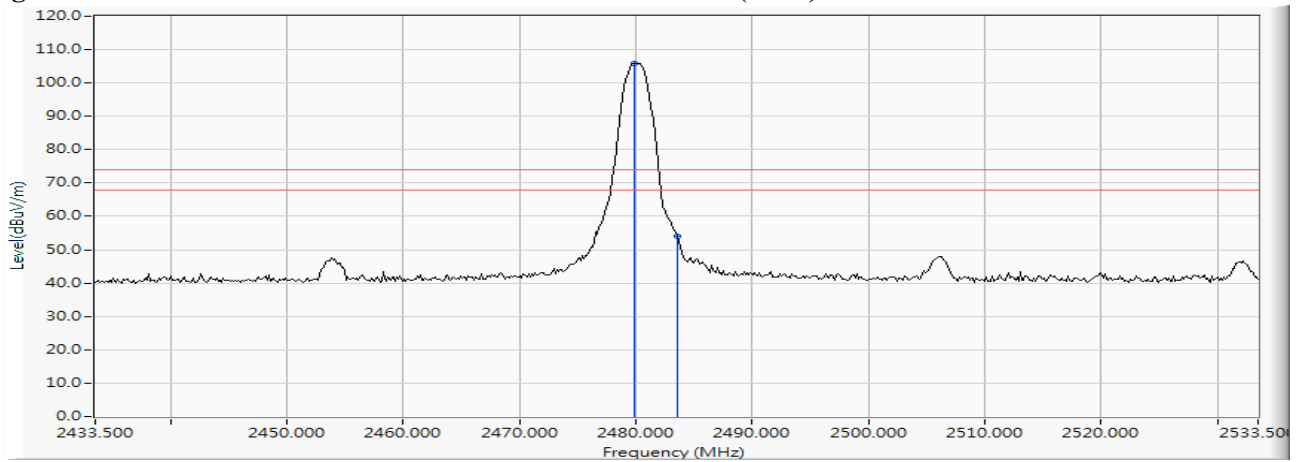

**Figure Channel 78: Horizontal (Average)**

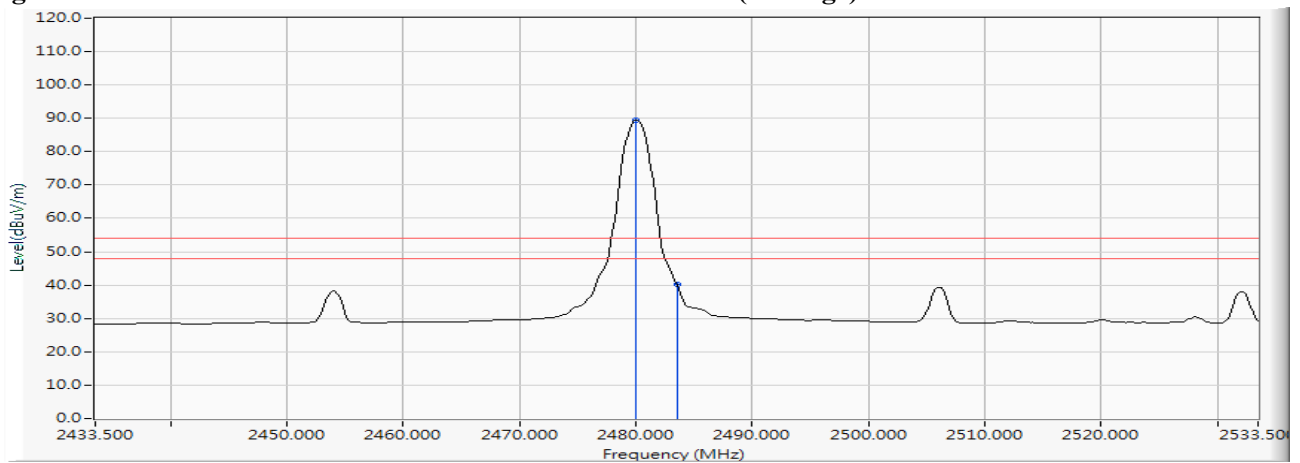

**Note:**

1. All readings above 1GHz are performed with peak and/or average measurements as necessary.
2. Peak measurements: RBW = 1MHz, VBW = 3 MHz, Sweep: Auto.
3. Average measurements: RBW = 1MHz, VBW = 10 Hz, Sweep: Auto.
4. “ \* ”, means this data is the worst emission level.
5. Measurement Level = Reading Level + Correction Factor.
6. The average measurement was not performed when the peak measured data is under the limit of average detection.

Product : Fanless Medical Grade Box PC  
 Test Item : Band Edge  
 Test Mode : Mode 1: Transmit - 1Mbps (2480MHz)  
 Test Date : 2017/09/14

**RF Radiated Measurement (VERTICAL):**

Channel No.	Frequency (MHz)	Correct Factor (dB)	Reading Level (dBμV)	Emission Level (dBμV/m)	Peak Limit (dBμV/m)	Average Limit (dBμV/m)	Result
78 (Peak)	2479.877	12.393	90.591	102.984	--	--	--
78 (Peak)	2483.500	12.403	39.264	51.667	74.00	54.00	Pass
78 (Average)	2480.022	12.393	74.669	87.062	--	--	--
78 (Average)	2483.500	12.403	26.029	38.432	74.00	54.00	Pass

**Figure Channel 78: VERTICAL (Peak)**

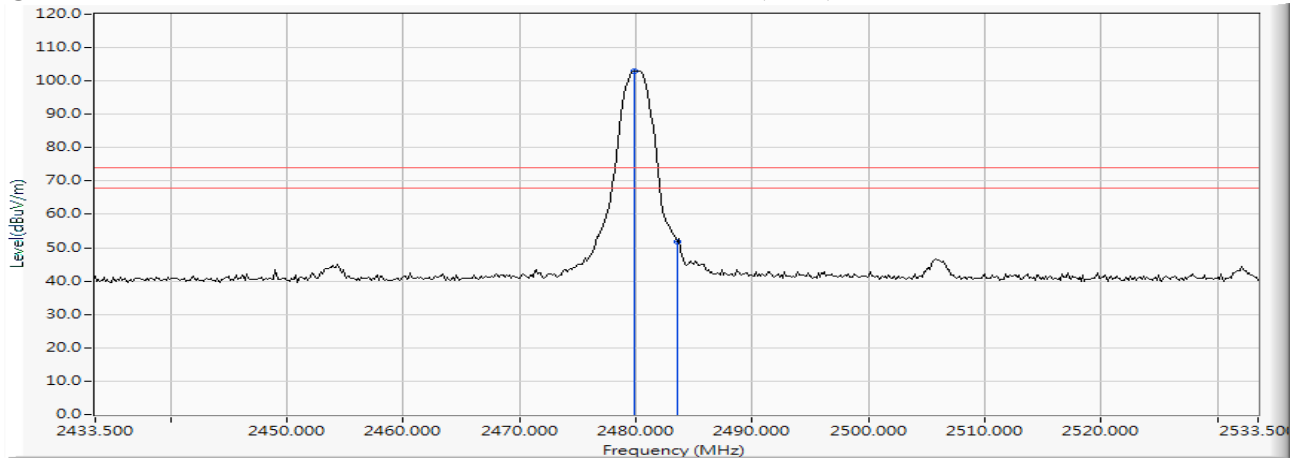

**Figure Channel 78: VERTICAL (Average)**

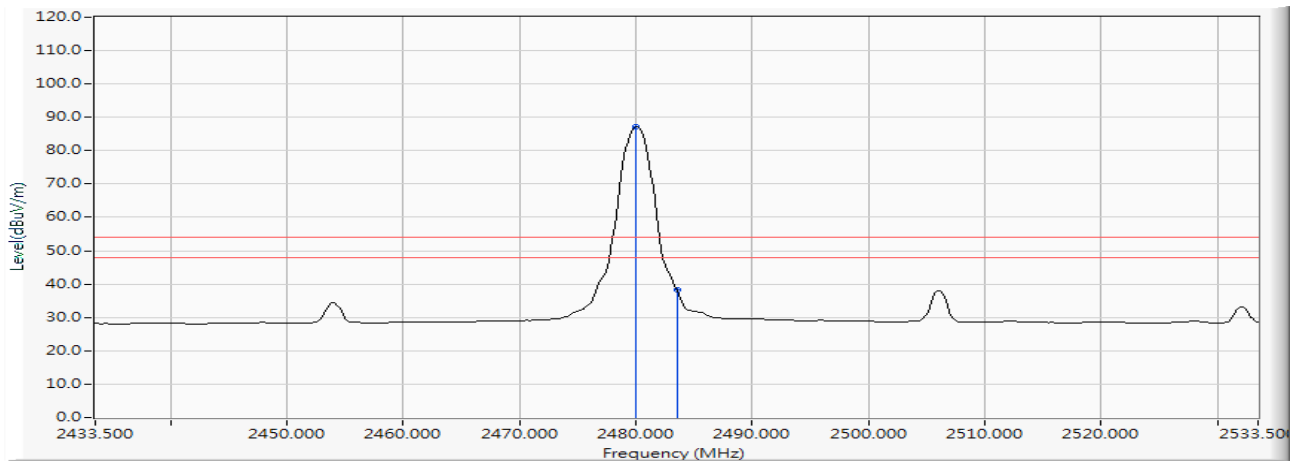

**Note:**

1. All readings above 1GHz are performed with peak and/or average measurements as necessary.
2. Peak measurements: RBW = 1MHz, VBW = 3 MHz, Sweep: Auto.
3. Average measurements: RBW = 1MHz, VBW = 10 Hz, Sweep: Auto.
4. “ \* ”, means this data is the worst emission level.
5. Measurement Level = Reading Level + Correction Factor.
6. The average measurement was not performed when the peak measured data is under the limit of average detection.



Product : Fanless Medical Grade Box PC  
 Test Item : Band Edge  
 Test Mode : Mode 2: Transmit - 3Mbps (2402MHz)  
 Test Date : 2017/09/14

**RF Radiated Measurement (Horizontal):**

Channel No.	Frequency (MHz)	Correct Factor (dB)	Reading Level (dBμV)	Emission Level (dBμV/m)	Peak Limit (dBμV/m)	Average Limit (dBμV/m)	Result
00 (Peak)	2376.522	12.109	33.260	45.369	74.00	54.00	Pass
00 (Peak)	2390.000	12.148	30.708	42.856	74.00	54.00	Pass
00 (Peak)	2400.000	12.176	61.378	73.554	--	--	--
00 (Peak)	2402.029	12.182	90.890	103.071	--	--	--
00 (Average)	2376.377	12.108	19.951	32.060	74.00	54.00	Pass
00 (Average)	2390.000	12.148	16.504	28.652	74.00	54.00	Pass
00 (Average)	2400.000	12.176	43.878	56.054	--	--	--
00 (Average)	2402.174	12.182	72.441	84.623	--	--	--

**Figure Channel 00: Horizontal (Peak)**

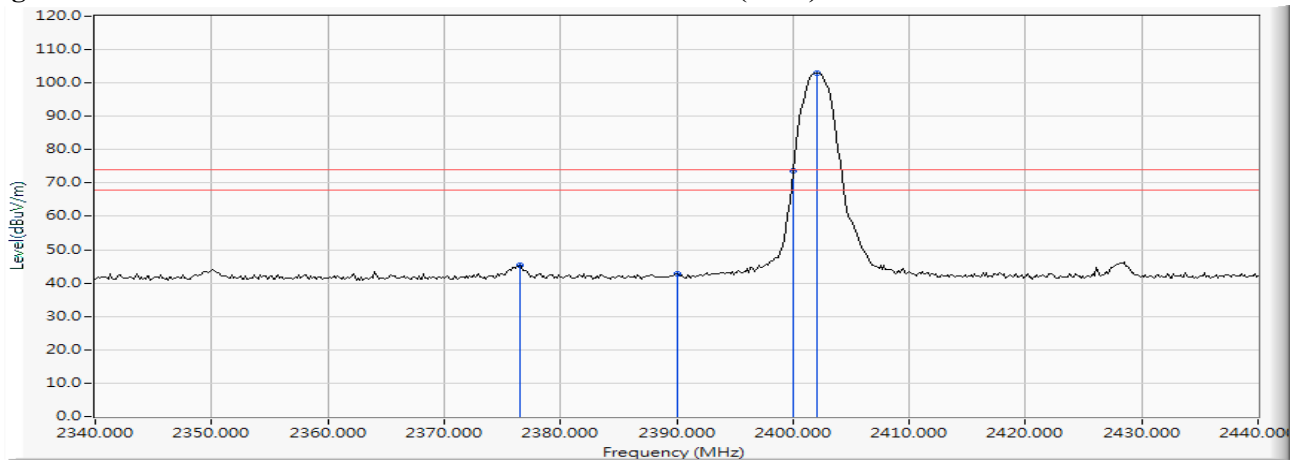

**Figure Channel 00: Horizontal (Average)**

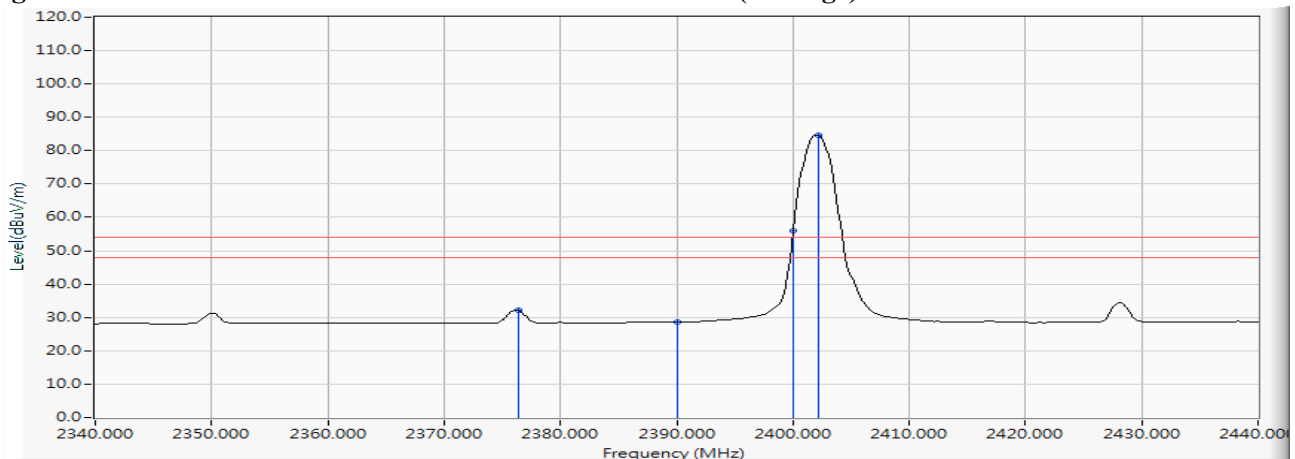

Note:

1. All readings above 1GHz are performed with peak and/or average measurements as necessary.
2. Peak measurements: RBW = 1MHz, VBW = 3 MHz, Sweep: Auto.
3. Average measurements: RBW = 1MHz, VBW = 10 Hz, Sweep: Auto.
4. “ \* ”, means this data is the worst emission level.
5. Measurement Level = Reading Level + Correction Factor.
6. The average measurement was not performed when the peak measured data is under the limit of average detection.

Product : Fanless Medical Grade Box PC  
 Test Item : Band Edge  
 Test Mode : Mode 2: Transmit - 3Mbps (2402MHz)  
 Test Date : 2017/09/14

**RF Radiated Measurement (VERTICAL):**

Channel No.	Frequency (MHz)	Correct Factor (dB)	Reading Level (dBµV)	Emission Level (dBµV/m)	Peak Limit (dBµV/m)	Average Limit (dBµV/m)	Result
00 (Peak)	2371.159	12.095	29.763	41.857	74.00	54.00	Pass
00 (Peak)	2390.000	12.148	27.626	39.774	74.00	54.00	Pass
00 (Peak)	2400.000	12.176	53.865	66.041	--	--	Pass
00 (Peak)	2402.029	12.182	84.016	96.197	--	--	--
00 (Average)	2390.000	12.148	15.826	27.974	74.00	54.00	Pass
00 (Average)	2400.000	12.176	38.368	50.544	--	--	Pass
00 (Average)	2402.029	12.182	66.925	79.106	--	--	--

**Figure Channel 00: VERTICAL (Peak)**

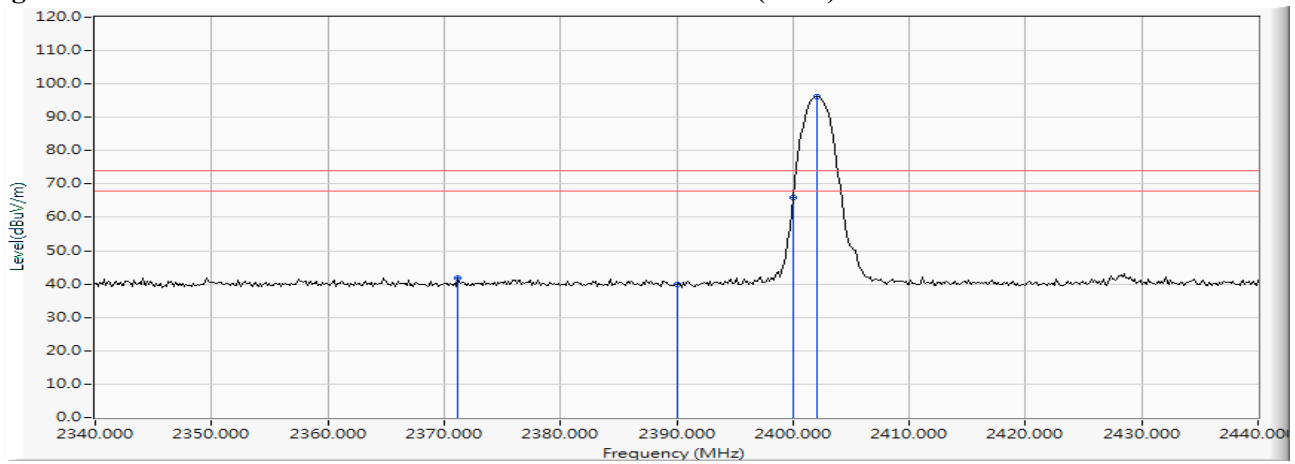

**Figure Channel 00: VERTICAL (Average)**

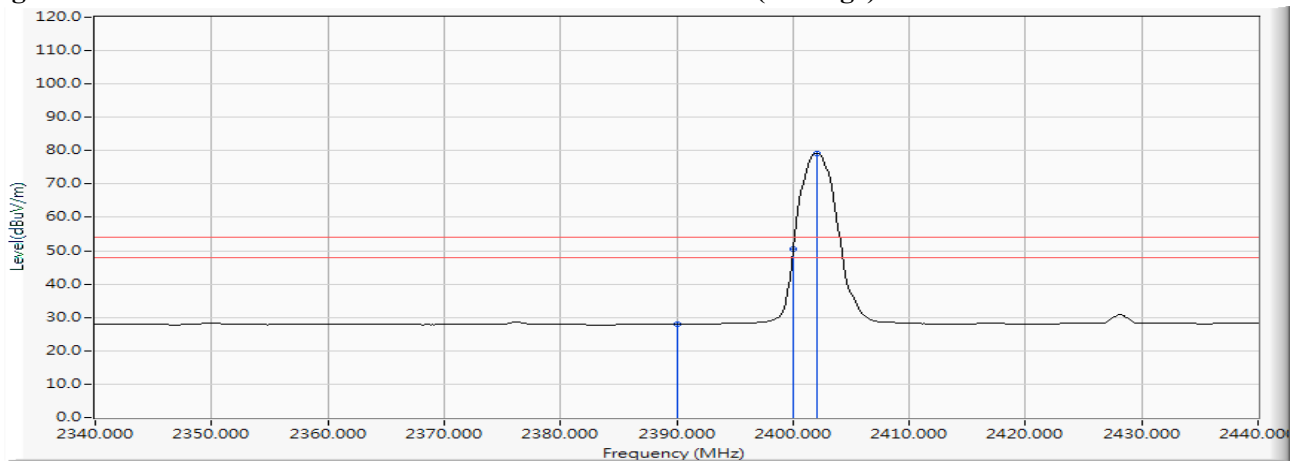

**Note:**

1. All readings above 1GHz are performed with peak and/or average measurements as necessary.
2. Peak measurements: RBW = 1MHz, VBW = 3 MHz, Sweep: Auto.
3. Average measurements: RBW = 1MHz, VBW = 10 Hz, Sweep: Auto.
4. “ \* ”, means this data is the worst emission level.
5. Measurement Level = Reading Level + Correction Factor.
6. The average measurement was not performed when the peak measured data is under the limit of average detection.

Product : Fanless Medical Grade Box PC  
 Test Item : Band Edge  
 Test Mode : Mode 2: Transmit - 3Mbps (2480MHz)  
 Test Date : 2017/09/14

**RF Radiated Measurement (Horizontal):**

Channel No.	Frequency (MHz)	Correct Factor (dB)	Reading Level (dBμV)	Emission Level (dBμV/m)	Peak Limit (dBμV/m)	Average Limit (dBμV/m)	Result
78 (Peak)	2480.022	12.393	91.371	103.764	--	--	--
78 (Peak)	2483.500	12.403	37.391	49.794	74.00	54.00	Pass
78 (Average)	2480.022	12.393	73.071	85.464	--	--	--
78 (Average)	2483.500	12.403	22.750	35.153	74.00	54.00	Pass
78 (Average)	2506.109	12.459	24.085	36.544	74.00	54.00	Pass

**Figure Channel 00: Horizontal (Peak)**

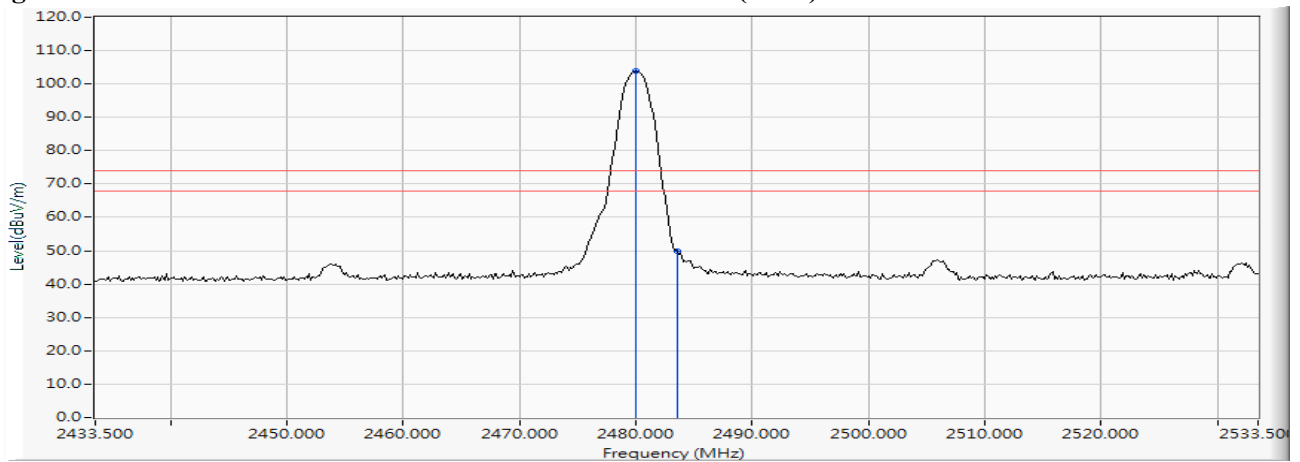

**Figure Channel 00: Horizontal (Average)**

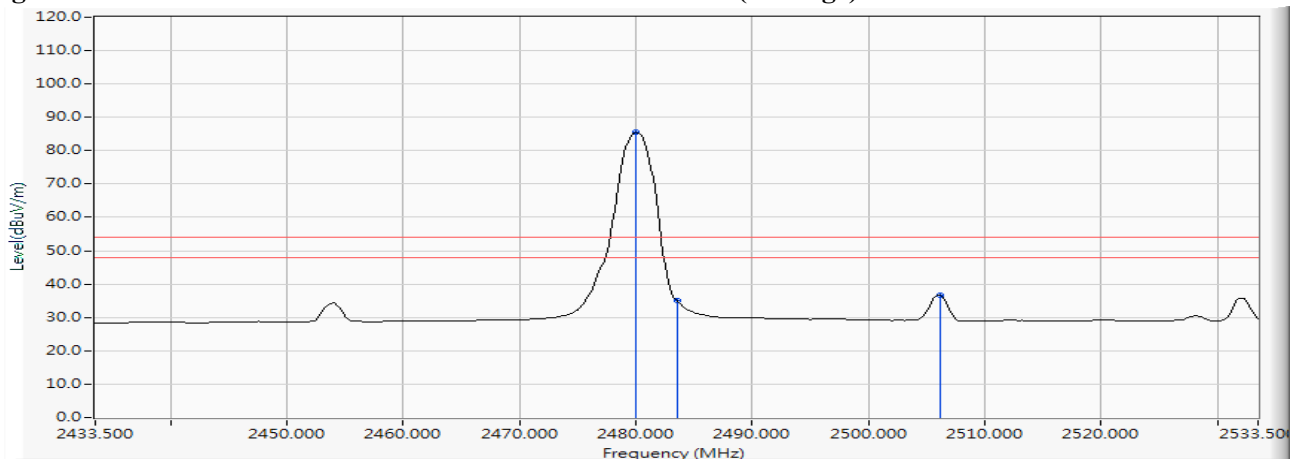

**Note:**

1. All readings above 1GHz are performed with peak and/or average measurements as necessary.
2. Peak measurements: RBW = 1MHz, VBW = 3 MHz, Sweep: Auto.
3. Average measurements: RBW = 1MHz, VBW = 10 Hz, Sweep: Auto.
4. “ \* ”, means this data is the worst emission level.
5. Measurement Level = Reading Level + Correction Factor.
6. The average measurement was not performed when the peak measured data is under the limit of average detection.

Product : Fanless Medical Grade Box PC  
 Test Item : Band Edge  
 Test Mode : Mode 2: Transmit - 3Mbps (2480MHz)  
 Test Date : 2017/09/14

**RF Radiated Measurement (VERTICAL):**

Channel No.	Frequency (MHz)	Correct Factor (dB)	Reading Level (dBµV)	Emission Level (dBµV/m)	Peak Limit (dBµV/m)	Average Limit (dBµV/m)	Result
78 (Peak)	2480.022	12.393	88.937	101.330	--	--	--
78 (Peak)	2483.500	12.403	35.112	47.515	74.00	54.00	Pass
78 (Average)	2480.022	12.393	71.135	83.528	--	--	--
78 (Average)	2483.500	12.403	21.392	33.795	74.00	54.00	Pass
78 (Average)	2505.819	12.458	22.103	34.561	74.00	54.00	Pass

**Figure Channel 78: VERTICAL (Peak)**

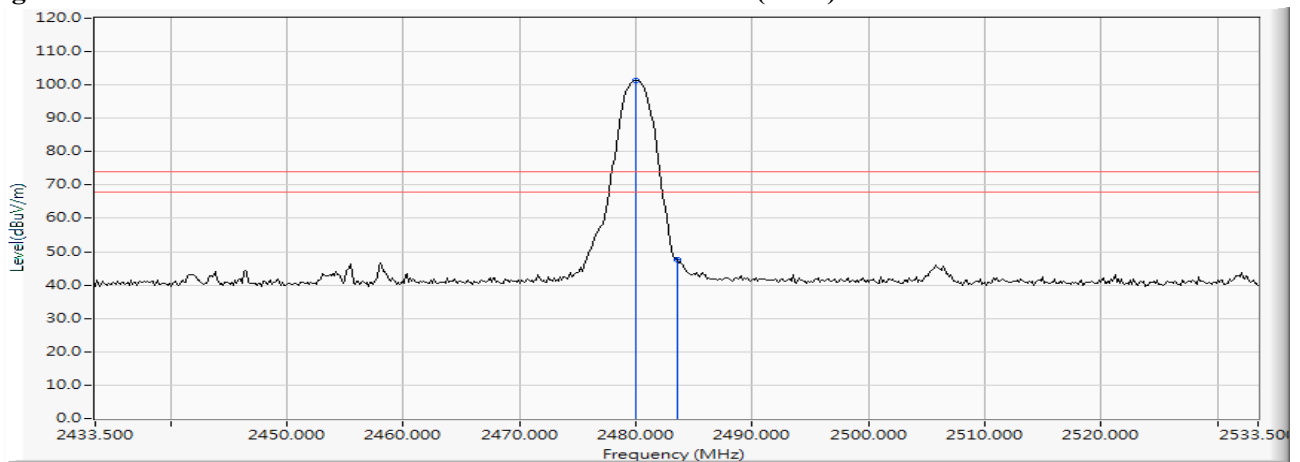

**Figure Channel 78: VERTICAL (Average)**

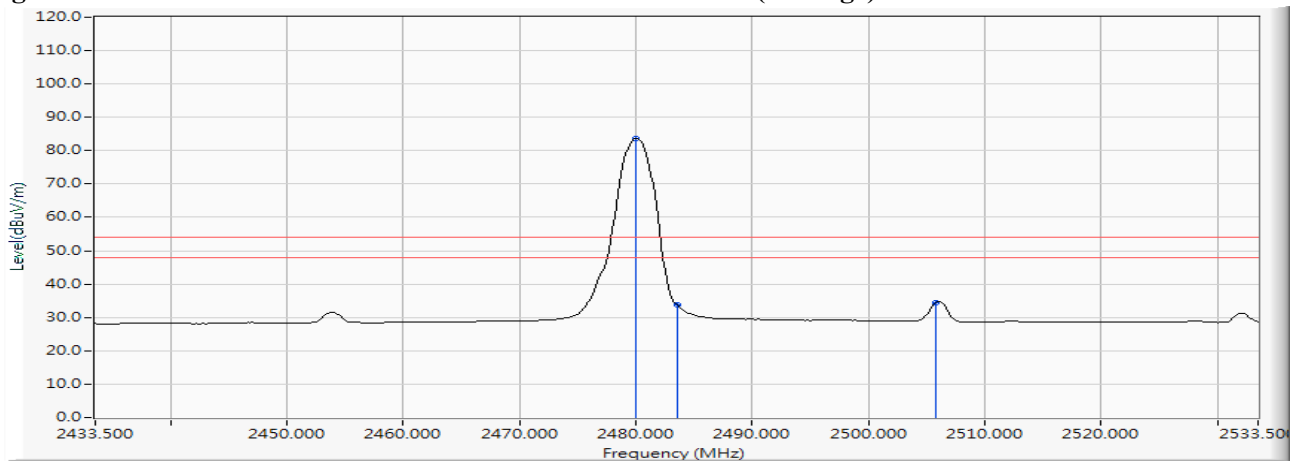

**Note:**

1. All readings above 1GHz are performed with peak and/or average measurements as necessary.
2. Peak measurements: RBW = 1MHz, VBW = 3 MHz, Sweep: Auto.
3. Average measurements: RBW = 1MHz, VBW = 10 Hz, Sweep: Auto.
4. “ \* ”, means this data is the worst emission level.
5. Measurement Level = Reading Level + Correction Factor.
6. The average measurement was not performed when the peak measured data is under the limit of average detection.

Product : Fanless Medical Grade Box PC  
 Test Item : Band Edge  
 Test Mode : Mode 1: Transmit - 1Mbps(Hopping off)

Measurement Level $\Delta$ (dB)	Result
> 20	PASS

Figure Channel 00:

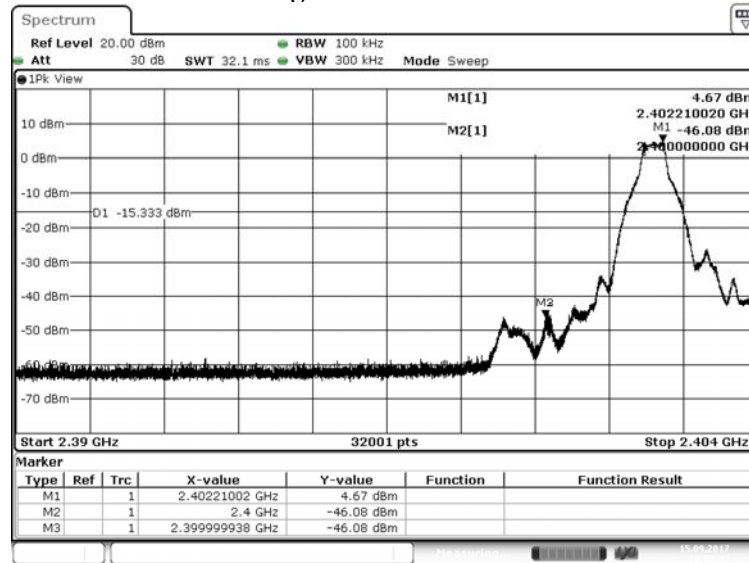

Date: 15.SEP.2017 20:03:42

Figure Channel 78:

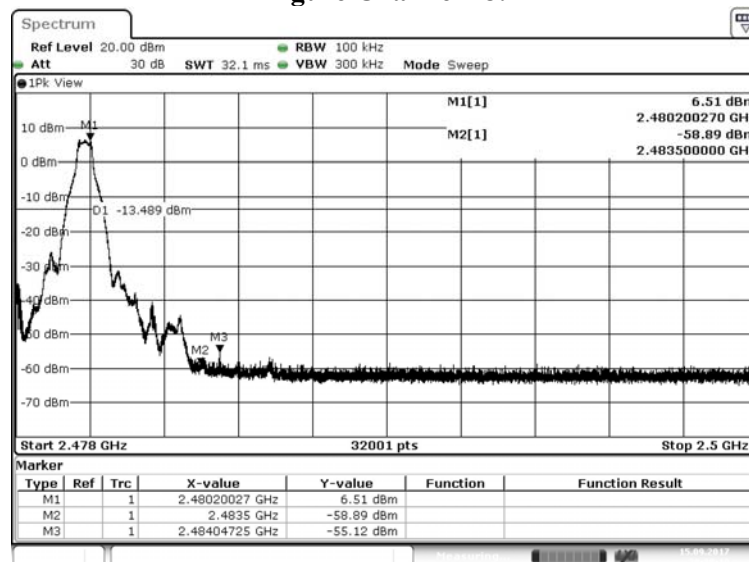

Date: 15.SEP.2017 20:38:20

Product : Fanless Medical Grade Box PC  
 Test Item : Band Edge  
 Test Mode : Mode 2: Transmit - 3Mbps (Hopping off)

Measurement Level $\Delta$ (dB)	Result
> 20	PASS

Figure Channel 00:

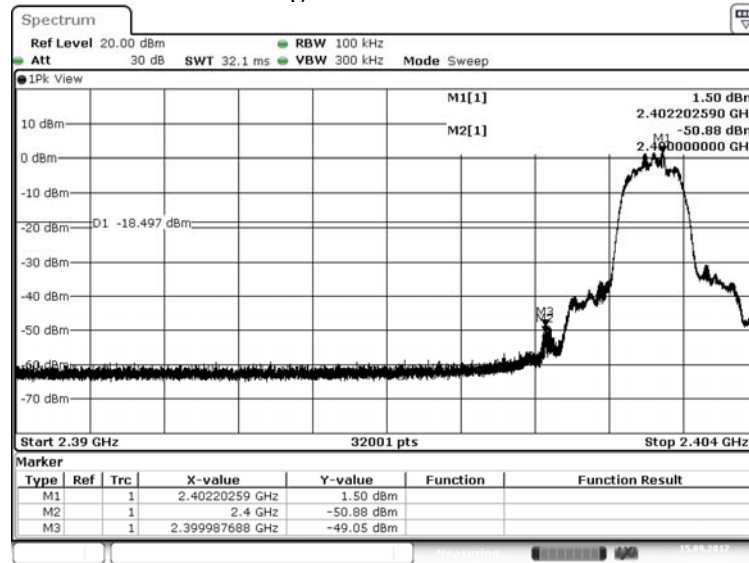

Date: 15.SEP.2017 21:18:28

Figure Channel 78:

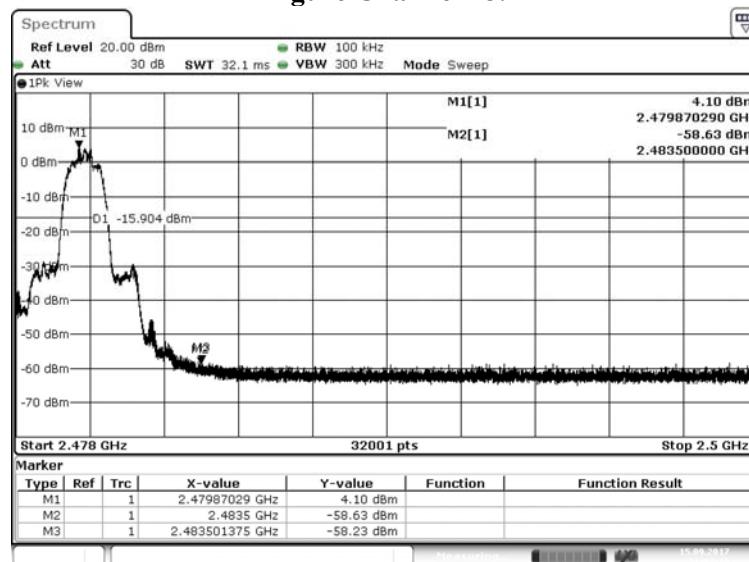

Date: 15.SEP.2017 21:57:20

Product : Fanless Medical Grade Box PC  
 Test Item : Band Edge  
 Test Mode : Mode 1: Transmit - 1Mbps(Hopping on)

Measurement Level	Result
$\Delta$ (dB)	
> 20	PASS

Figure Channel Hopping:

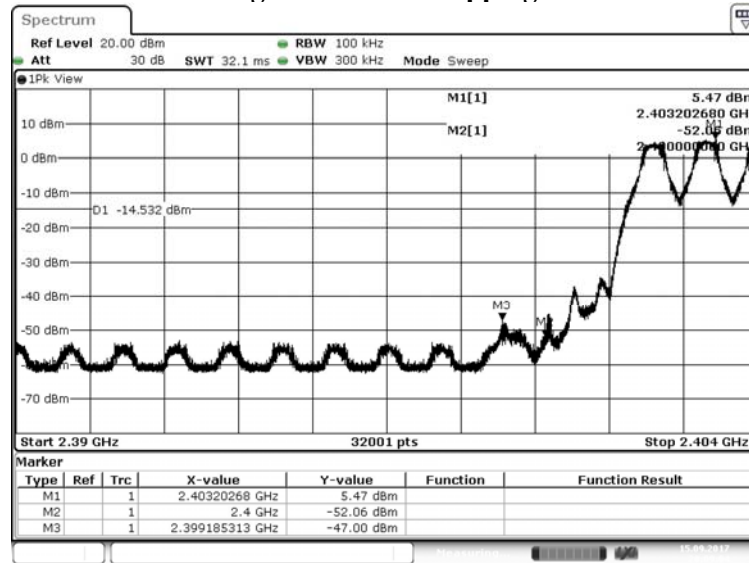

Date: 15.SEP.2017 20:09:05

Figure Channel Hopping:

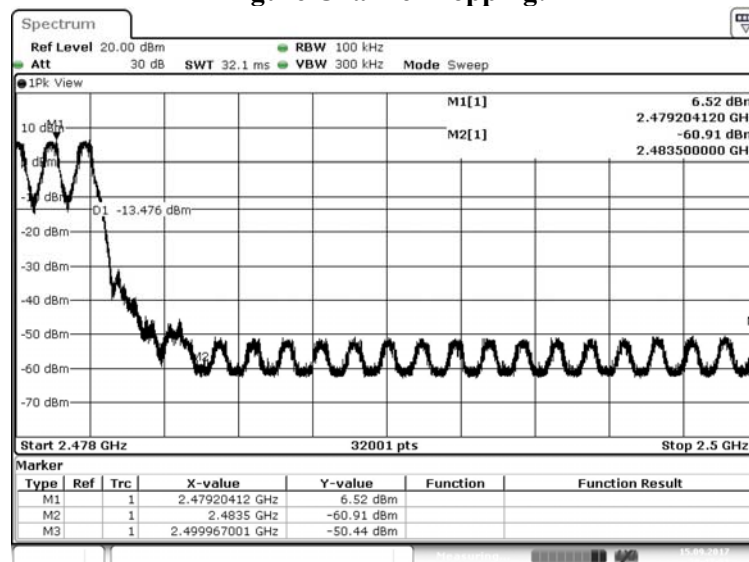

Date: 15.SEP.2017 20:47:52

Product : Fanless Medical Grade Box PC  
 Test Item : Band Edge  
 Test Mode : Mode 2: Transmit - 3Mbps (Hopping on)

Measurement Level	Result
$\Delta$ (dB)	
> 20	PASS

Figure Channel Hopping:

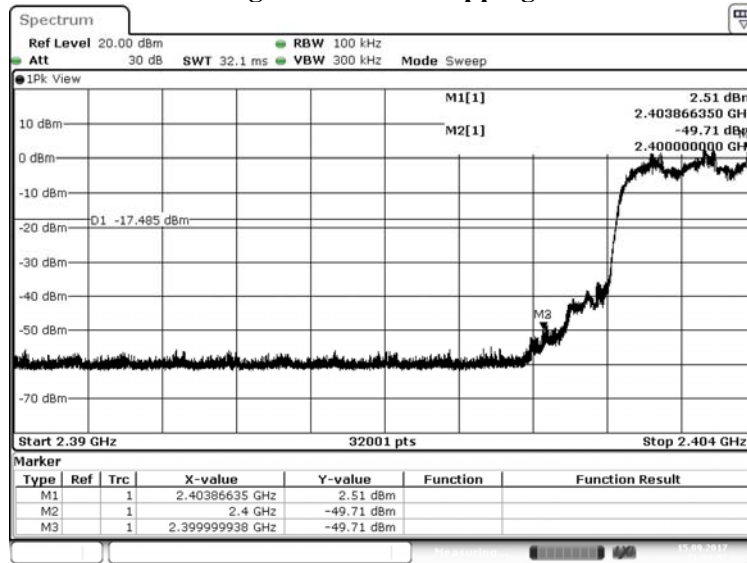

Date: 15.SEP.2017 21:30:52

Figure Channel Hopping:

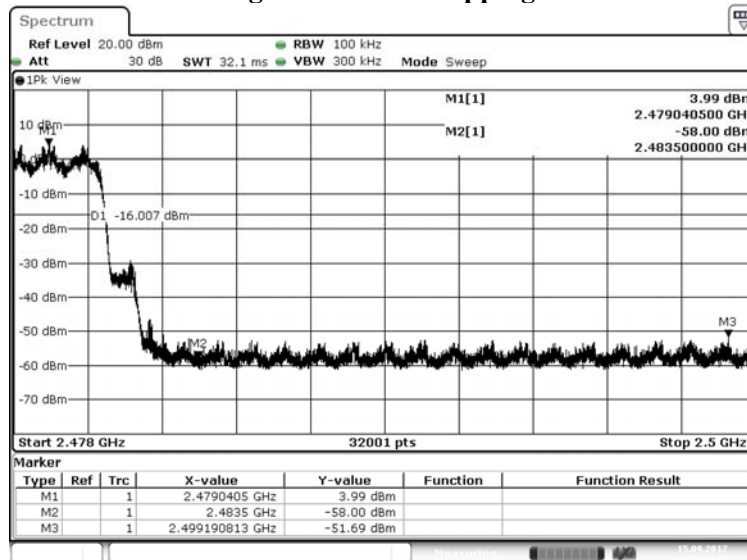

Date: 15.SEP.2017 22:03:11



## 7. Channel Number

### 7.1. Test Setup

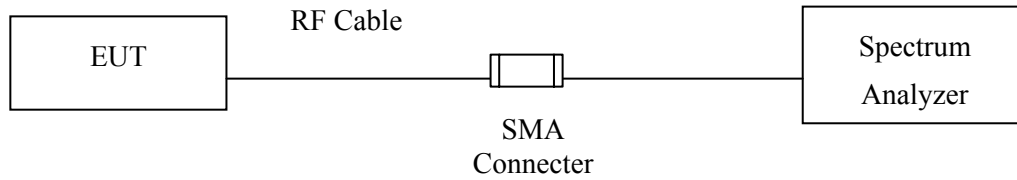

### 7.2. Limit

Frequency hopping systems operating in the 2400-2483.5 MHz bands shall use at least 75 hopping frequencies.

### 7.3. Test Procedure

The EUT was setup to ANSI C63.4, 2014; tested to FHSS test procedure of FCC Public Notice DA 00-705 for compliance to FCC 47CFR 15.247 requirements.

### 7.4. Uncertainty

N/A

### 7.5. Test Result of Channel Number

Product : Fanless Medical Grade Box PC  
 Test Item : Channel Number  
 Test Mode : Mode 1: Transmit - 1Mbps

Frequency Range (MHz)	Measurement (Hopping Channel)	Required Limit (Hopping Channel)	Result
2402 ~ 2480	79	>75	Pass

2402-2421MHz

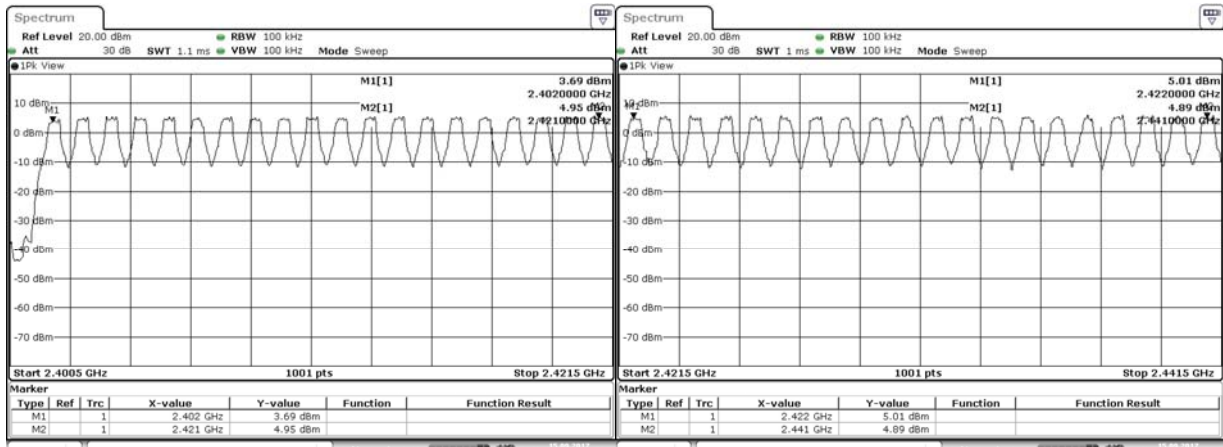

Date: 15 SEP 2017 20:53:54

2422-2441MHz

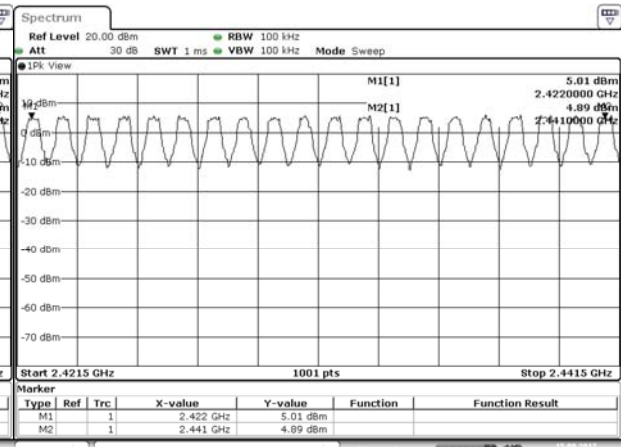

Date: 15 SEP 2017 20:55:13

2442-2461MHz

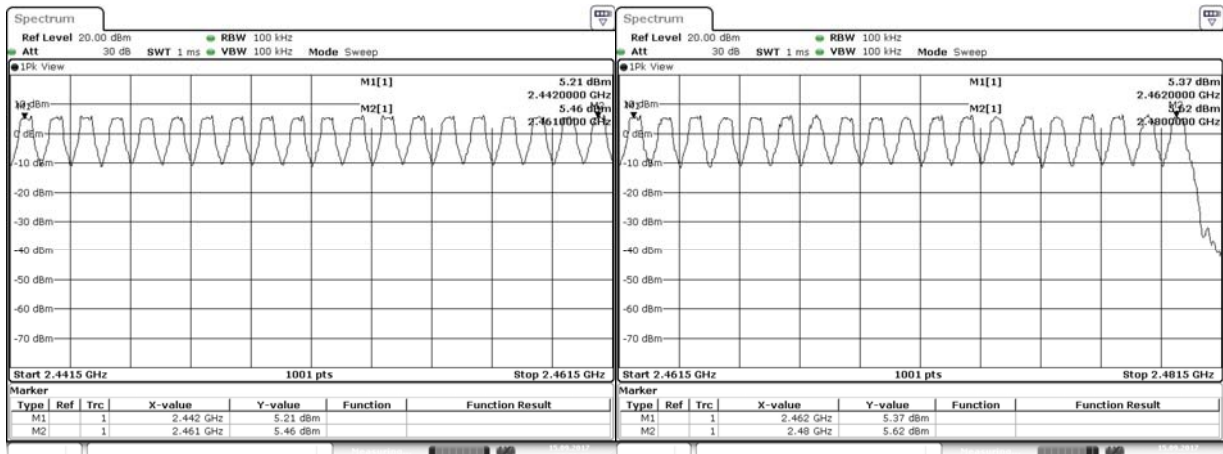

Date: 15 SEP 2017 20:58:25

2462-2480MHz

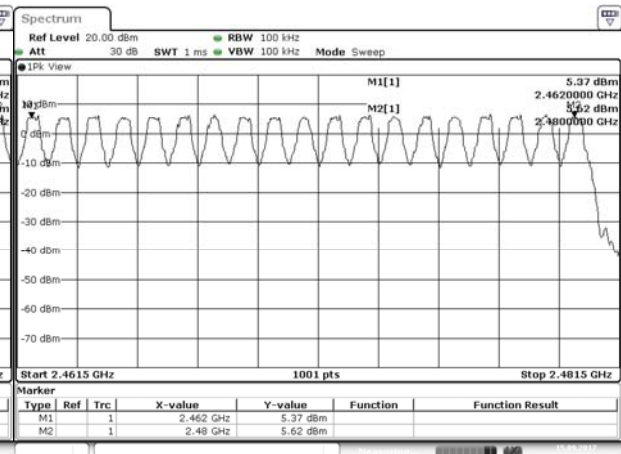

Date: 15 SEP 2017 20:59:56

Product : Fanless Medical Grade Box PC  
 Test Item : Channel Number  
 Test Mode : Mode 2: Transmit - 3Mbps

Frequency Range (MHz)	Measurement (Hopping Channel)	Required Limit (Hopping Channel)	Result
2402 ~ 2480	79	>75	Pass

2402-2421MHz

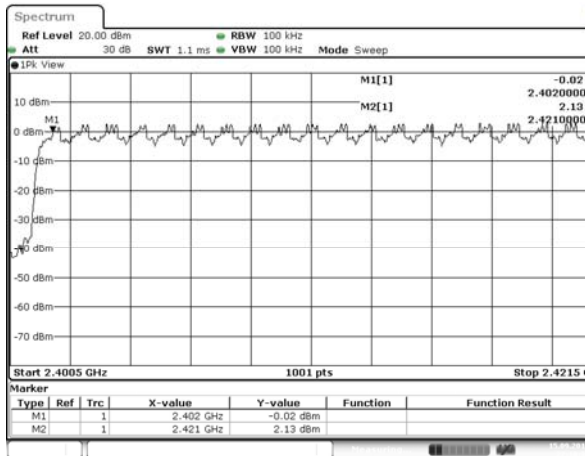

Date: 15.SEP.2017 22:10:39

2422-2441MHz

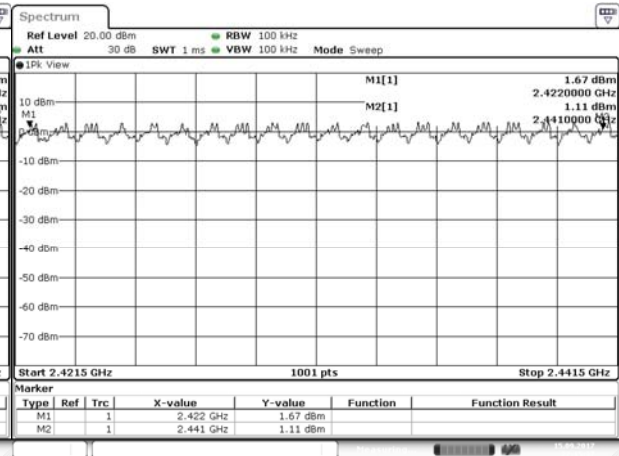

Date: 15.SEP.2017 22:15:38

2442-2461MHz

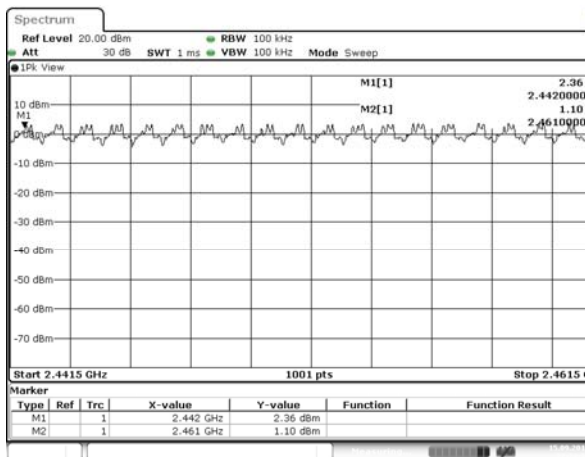

Date: 15.SEP.2017 22:23:35

2462-2480MHz

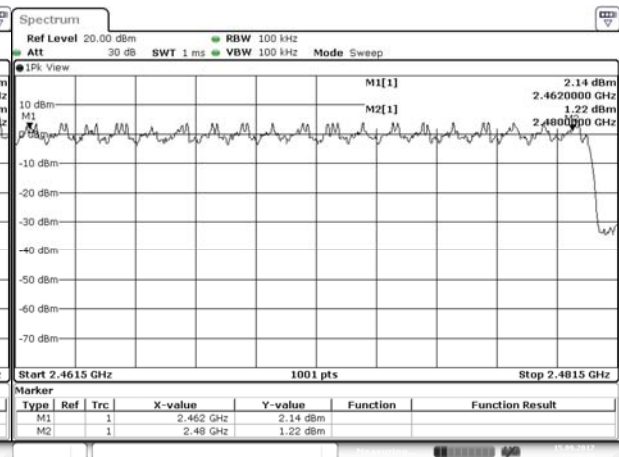

Date: 15.SEP.2017 22:26:29

## 8. Channel Separation

### 8.1. Test Setup

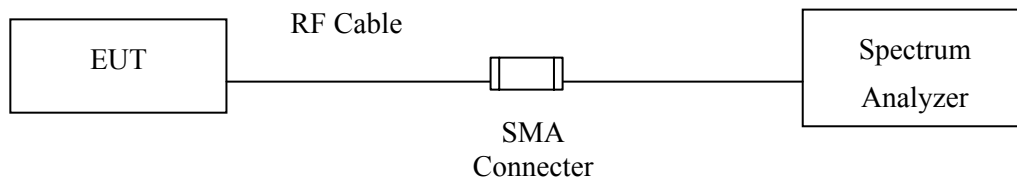

### 8.2. Limit

Frequency hopping systems shall have hopping channel carrier frequencies separated by a minimum of 25 kHz or the 20 dB bandwidth of the hopping channel, whichever is greater.

### 8.3. Test Procedure

The EUT was setup to ANSI C63.4, 2014; tested to FHSS test procedure of FCC Public Notice DA 00-705 for compliance to FCC 47CFR 15.247 requirements.

### 8.4. Uncertainty

$\pm 279.2\text{Hz}$

### 8.5. Test Result of Channel Separation

Product : Fanless Medical Grade Box PC  
 Test Item : Channel Separation  
 Test Mode : Mode 1: Transmit - 1Mbps

Channel No.	Frequency (MHz)	Measurement Level (kHz)	Limit (kHz)	Limit of (2/3)*20dB Bandwidth (kHz)	Result
00	2402	1000	>25 kHz	640.0	Pass
39	2441	1000	>25 kHz	648.0	Pass
78	2480	1000	>25 kHz	640.0	Pass

NOTE: The 20dB Bandwidth is refer to section 10.

Channel 00 (2402MHz)

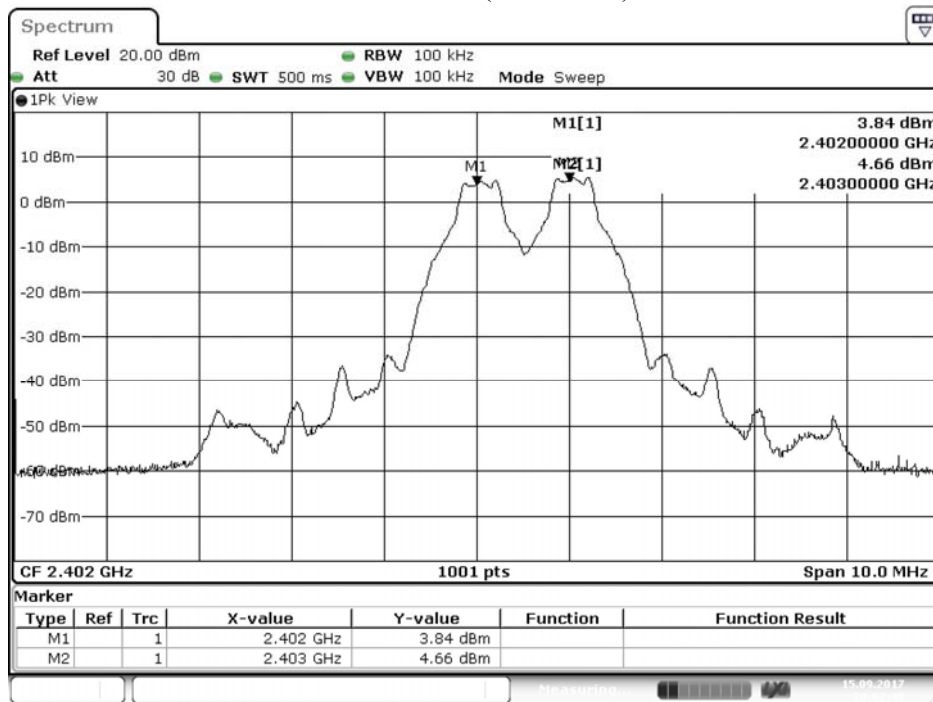

Date: 15.SEP.2017 20:02:48

### Channel 39 (2441MHz)

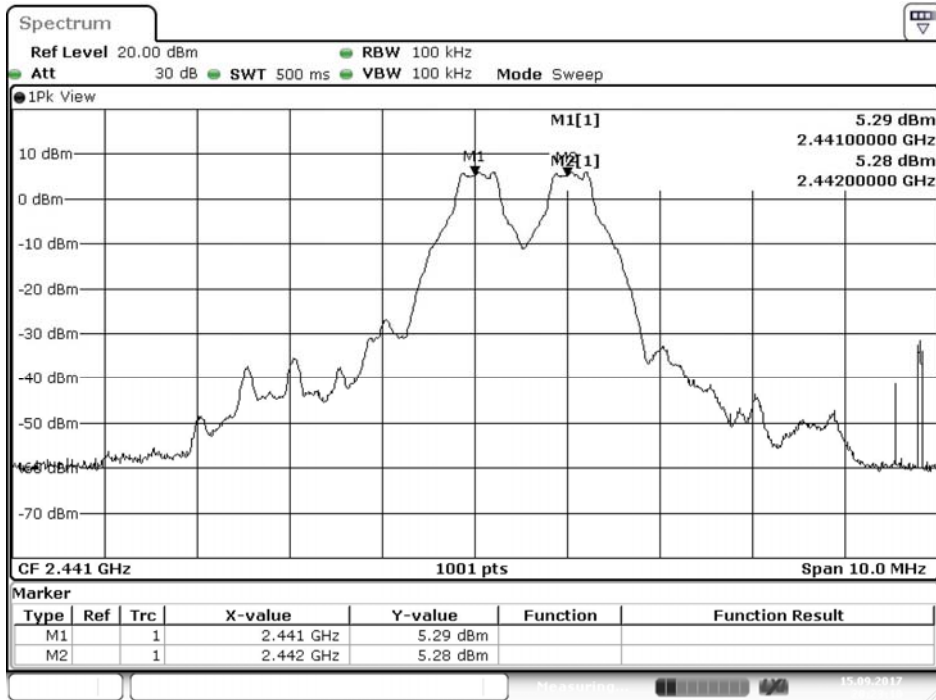

Date: 15.SEP.2017 20:23:10

### Channel 78 (2480MHz)

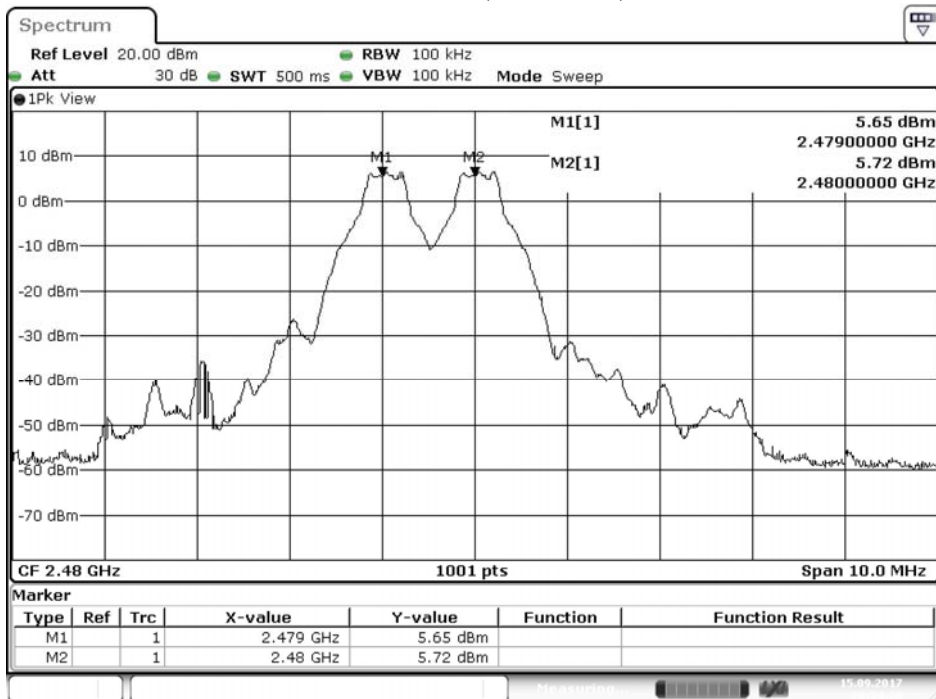

Date: 15.SEP.2017 20:34:21

Product : Fanless Medical Grade Box PC  
 Test Item : Channel Separation  
 Test Mode : Mode 2: Transmit - 3Mbps

Channel No.	Frequency (MHz)	Measurement Level (kHz)	Limit (kHz)	Limit of (2/3)*20dB Bandwidth (kHz)	Result
00	2402	1000	>25 kHz	856.0	Pass
39	2441	1000	>25 kHz	852.0	Pass
78	2480	1000	>25 kHz	854.0	Pass

NOTE: The 20dB Bandwidth is refer to section 10.

Channel 00 (2402MHz)

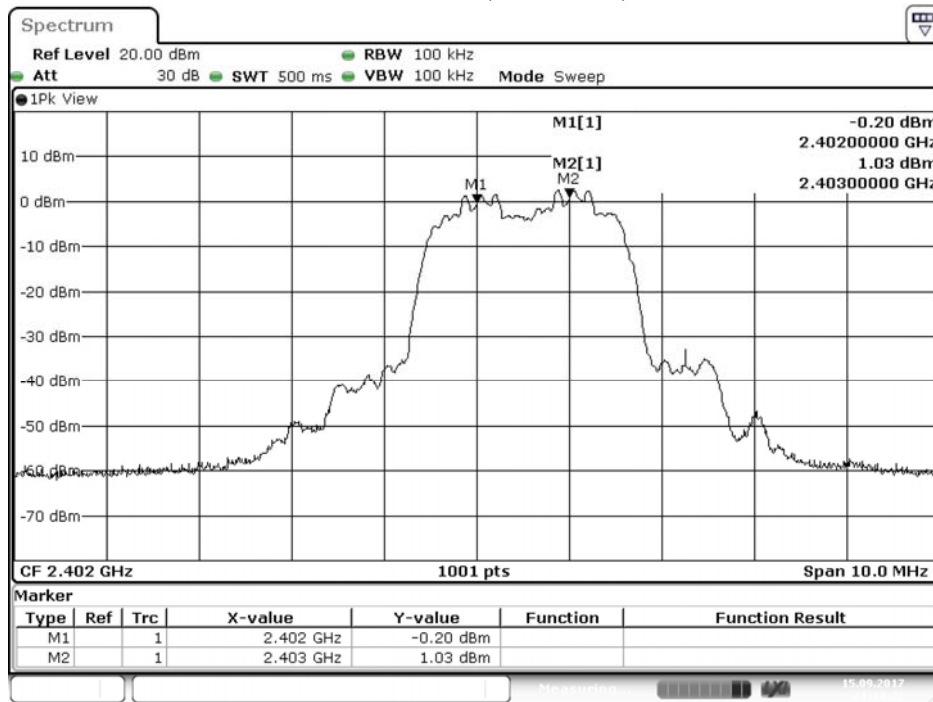

Date: 15.SEP.2017 21:14:23

### Channel 39 (2441MHz)

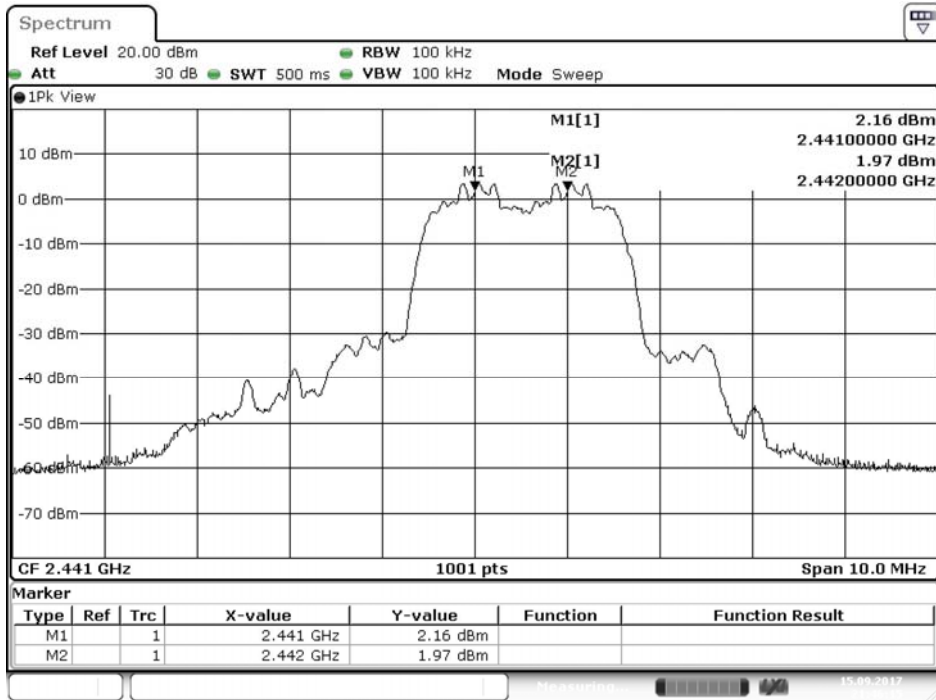

### Channel 78 (2480MHz)

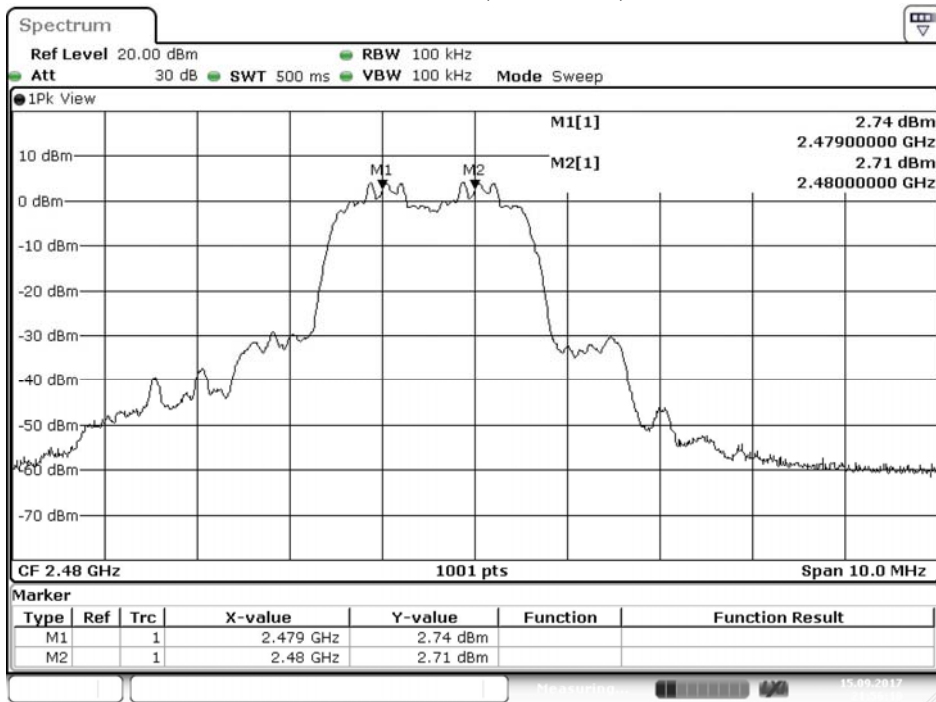



## 9. Dwell Time

### 9.1. Test Setup

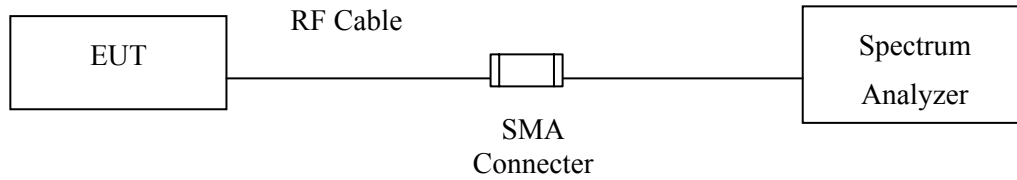

### 9.2. Limit

The average time of occupancy on any channel shall not be greater than 0.4 seconds within a period of 0.4 seconds multiplied by the number of hopping channels employed.

### 9.3. Test Procedure

The EUT was setup to ANSI C63.4, 2014; tested to FHSS test procedure of FCC Public Notice DA 00-705 for compliance to FCC 47CFR 15.247 requirements.

### 9.4. Uncertainty

$\pm 2.31\text{msec}$

### 9.5. Test Result of Dwell Time

Product : Fanless Medical Grade Box PC  
 Test Item : Dwell Time  
 Test Mode : Mode 1: Transmit - 1Mbps (Channel 00,39,78)

Frequency (MHz)	Time slot length (ms)	Hopping of Number	Sweep time (ms)	Duty cycle	Dwell Time (Sec)	Limit (Sec)	Result
2402	2.887	13	50	0.75	0.300	0.4	Pass
2441	2.887	13	50	0.75	0.300	0.4	Pass
2480	2.897	13	50	0.75	0.301	0.4	Pass

Duty cycle = ((Time slot length(ms)\*Hopping of Number) / Sweep time (ms)

Dwell time = (Duty cycle /79) \* (79\*0.4)

CH 00 Hopping of Number

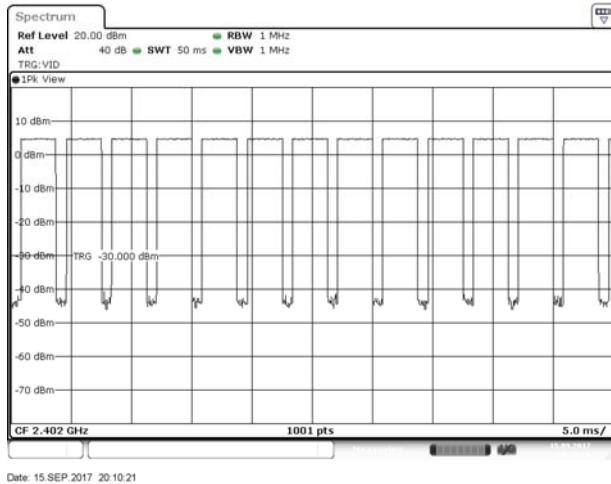

Date: 15.SEP.2017 20:10:21

CH 00 Time slot length

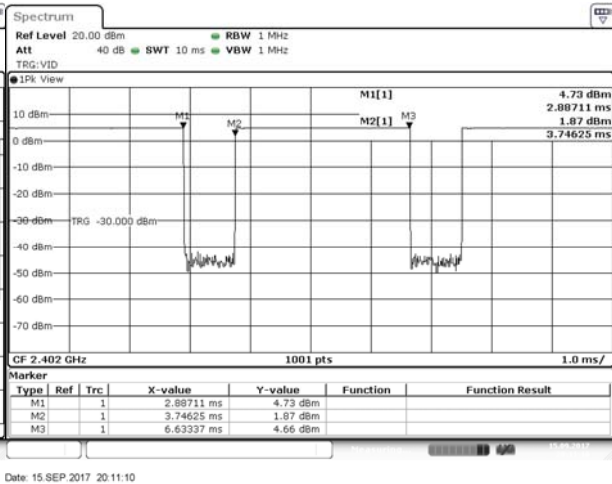

Date: 15.SEP.2017 20:11:10

CH39 Hopping of Number

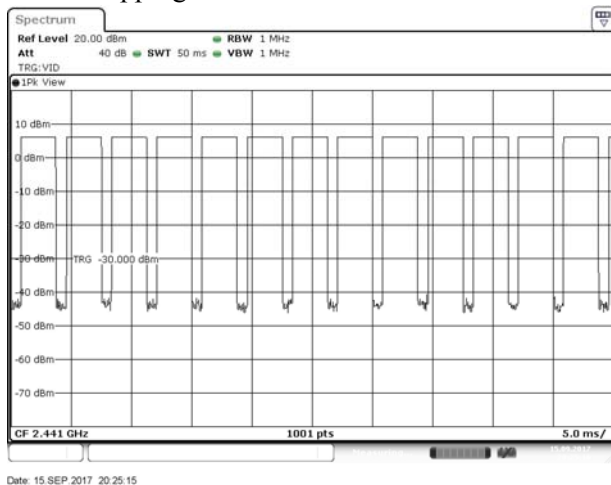

Date: 15.SEP.2017 20:25:15

CH 39 Time slot length

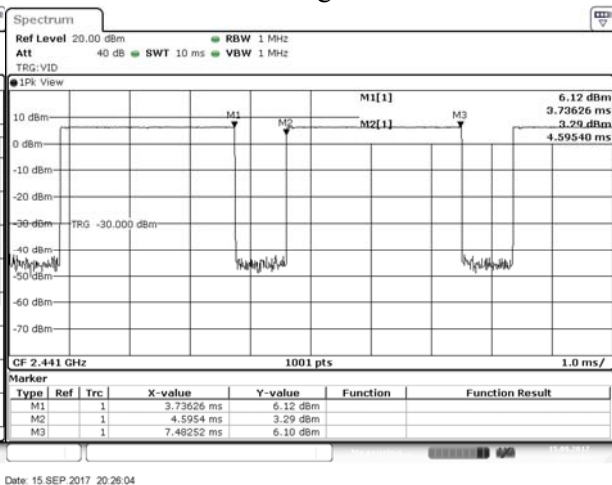

Date: 15.SEP.2017 20:26:04

CH 78 Hopping of Number

CH 78 Time slot length

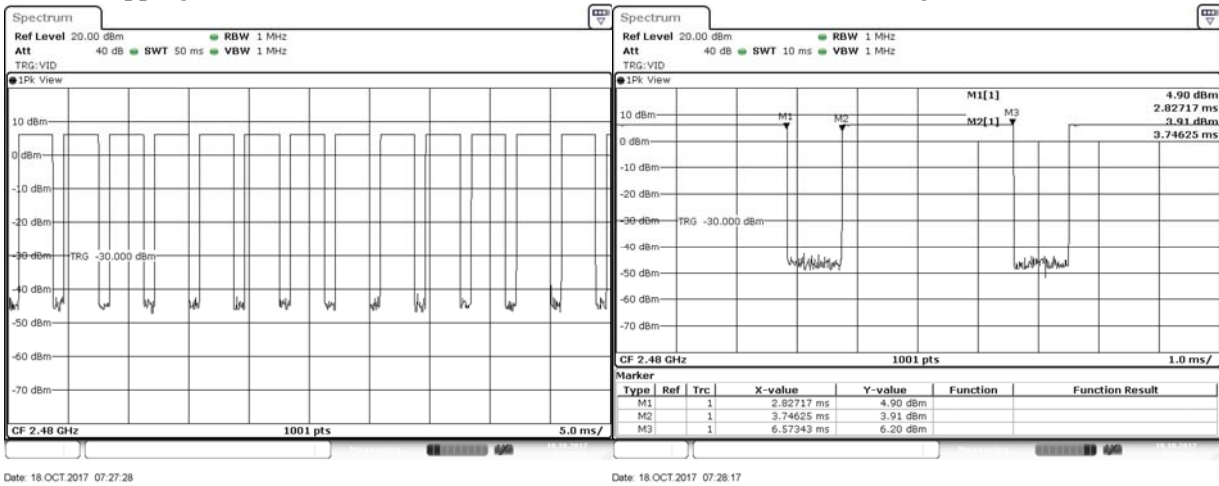

Note:

The dwell times of the packet type of DH1, DH3, and DH5 are tested. Only the worst case is shown on the report.

Product : Fanless Medical Grade Box PC  
 Test Item : Dwell Time  
 Test Mode : Mode 2: Transmit - 3Mbps (Channel 00,39,78)

Frequency (MHz)	Time slot length (ms)	Hopping of Number	Sweep time (ms)	Duty cycle	Dwell Time (Sec)	Limit (Sec)	Result
2402	2.897	13	50	0.75	0.301	0.4	Pass
2441	2.897	13	50	0.75	0.301	0.4	Pass
2480	2.897	13	50	0.75	0.301	0.4	Pass

Duty cycle = ((Time slot length(ms)\*Hopping of Number) / Sweep time (ms))

Dwell time = (Duty cycle / 79) \* (79\*0.4)

CH 00 Hopping of Number

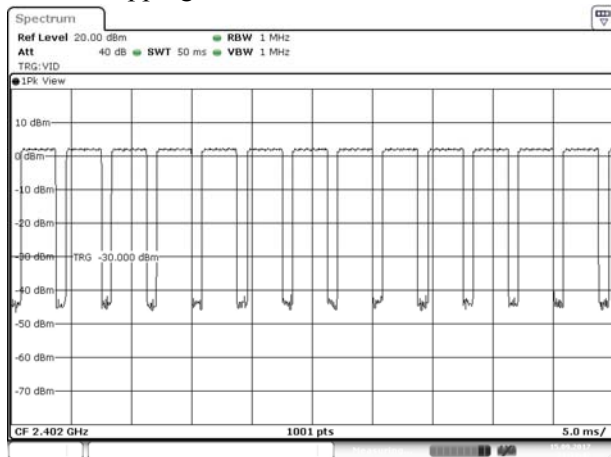

Date: 15.SEP.2017 21:33:43

CH 00 Time slot length

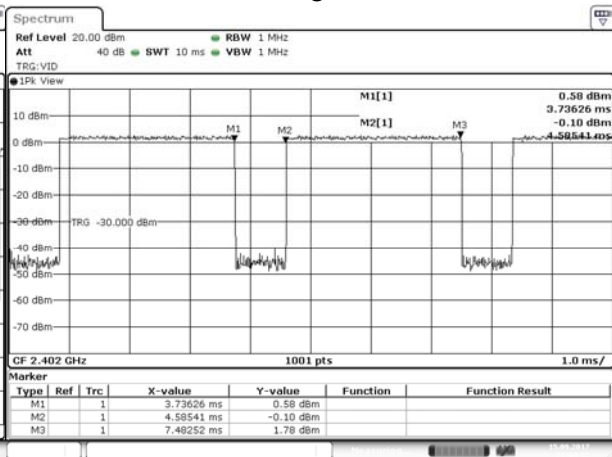

Date: 15.SEP.2017 21:34:32

CH39 Hopping of Number

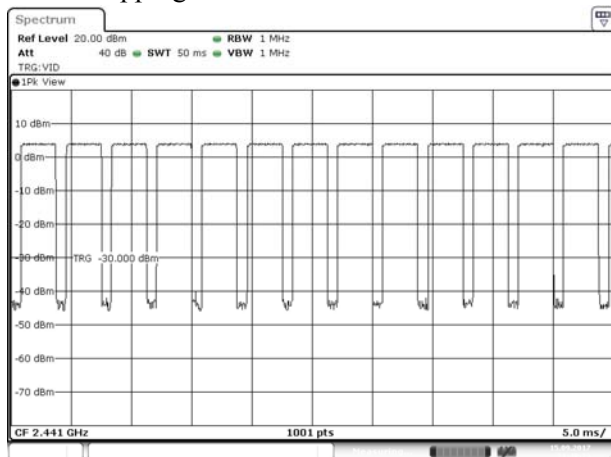

Date: 15.SEP.2017 21:48:24

CH 39 Time slot length

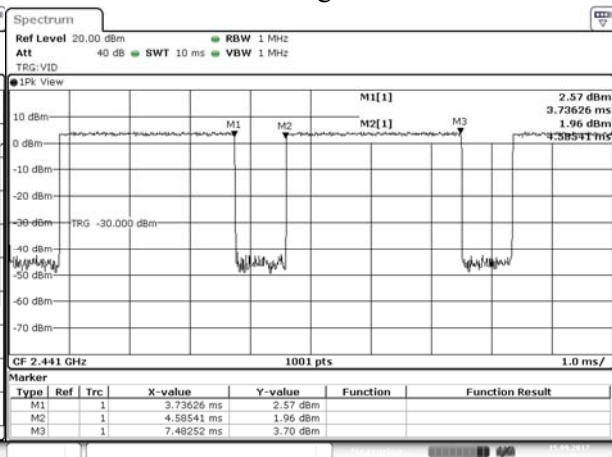

Date: 15.SEP.2017 21:49:13

CH 78 Hopping of Number

CH 78 Time slot length

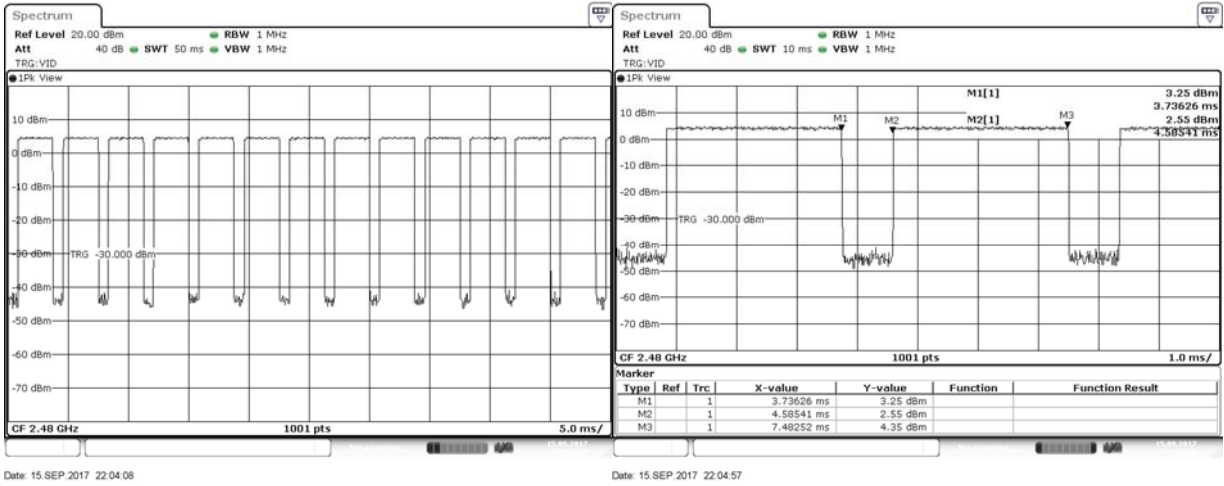

Note:

The dwell times of the packet type of DH1, DH3, and DH5 are tested. Only the worst case is shown on the report.

## 10. Occupied Bandwidth

### 10.1. Test Setup

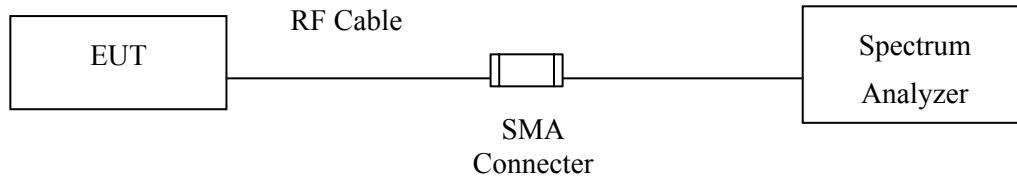

### 10.2. Limits

N/A

### 10.3. Test Procedure

The EUT was setup to ANSI C63.4, 2014; tested to FHSS test procedure of FCC Public Notice DA 00-705 for compliance to FCC 47CFR 15.247 requirements.

### 10.4. Uncertainty

$\pm 279.2\text{Hz}$

### 10.5. Test Result of Occupied Bandwidth

Product : Fanless Medical Grade Box PC  
 Test Item : Occupied Bandwidth Data  
 Test Mode : Mode 1: Transmit - 1Mbps

Channel No.	Frequency (MHz)	Measurement Level (kHz)	Required Limit (kHz)	Result
00	2402	960	--	NA
39	2441	972	--	NA
78	2480	960	--	NA

Figure Channel 00:

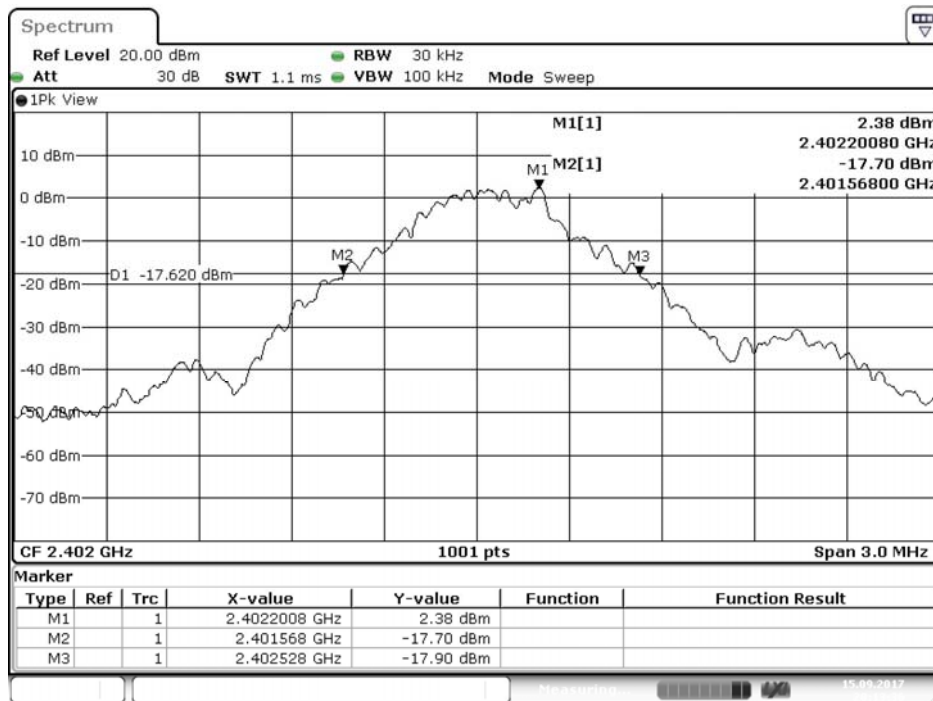

Date: 15.SEP.2017 20:13:36

Figure Channel 39:

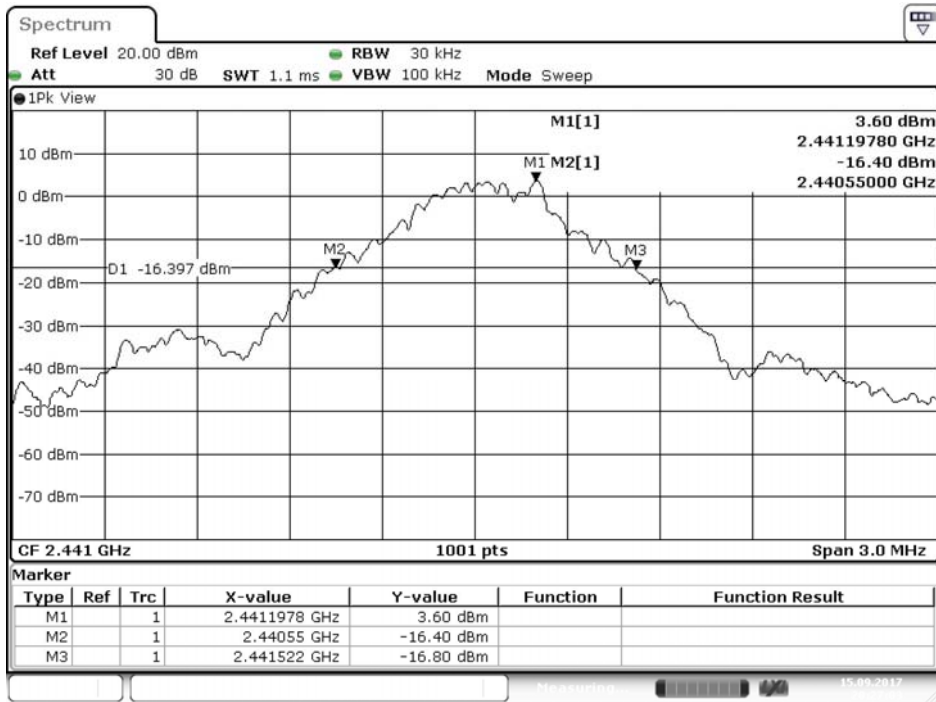

Date: 15.SEP.2017 20:27:04

Figure Channel 78:

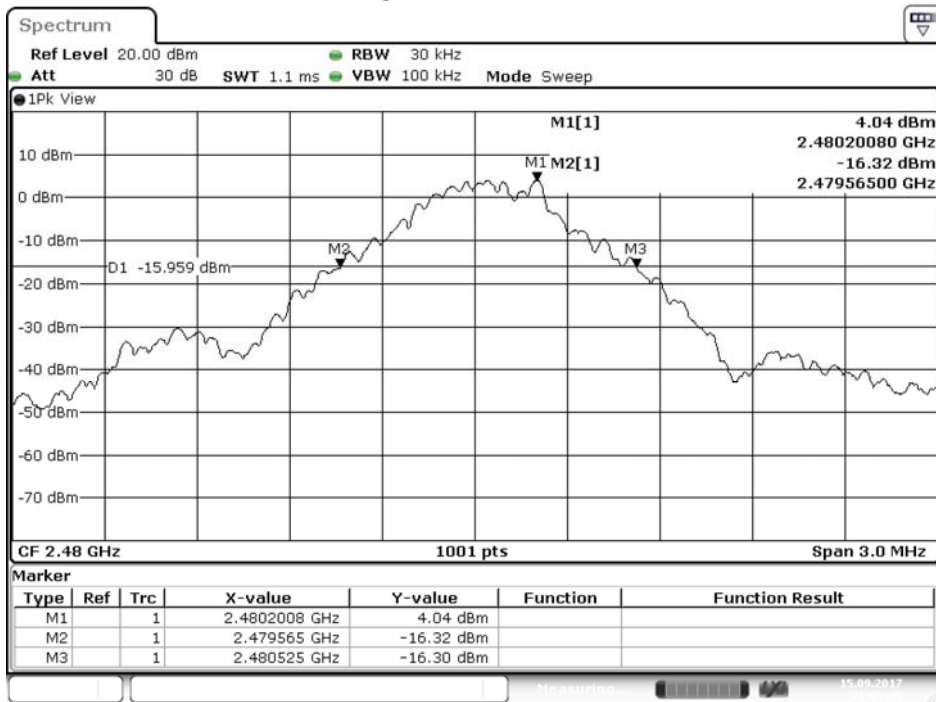

Date: 15.SEP.2017 21:05:45



Product : Fanless Medical Grade Box PC  
 Test Item : Occupied Bandwidth Data  
 Test Mode : Mode 2: Transmit - 3Mbps

Channel No.	Frequency (MHz)	Measurement Level (kHz)	Required Limit (kHz)	Result
00	2402	1284	--	NA
39	2441	1278	--	NA
78	2480	1281	--	NA

Figure Channel 00:

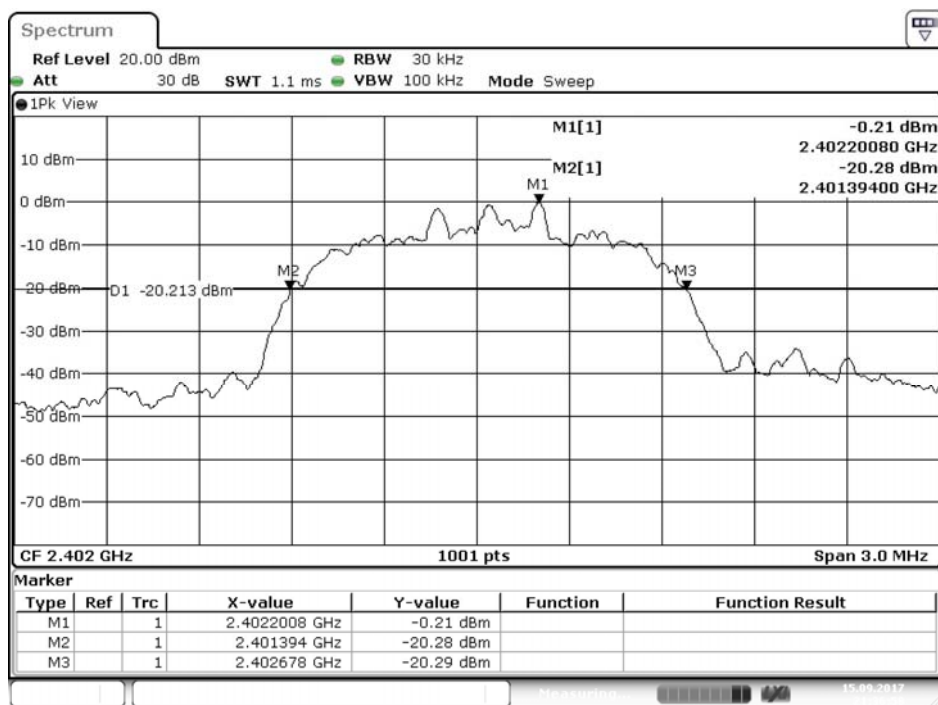

Date: 15.SEP.2017 21:36:58

Figure Channel 39:

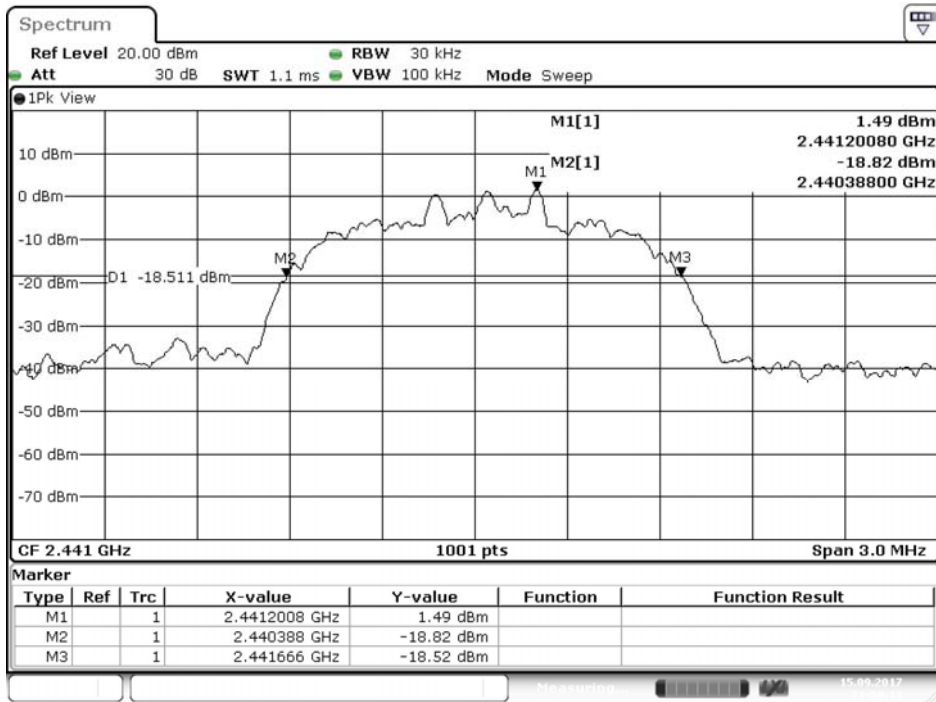

Date: 15.SEP.2017 21:50:13

Figure Channel 78:

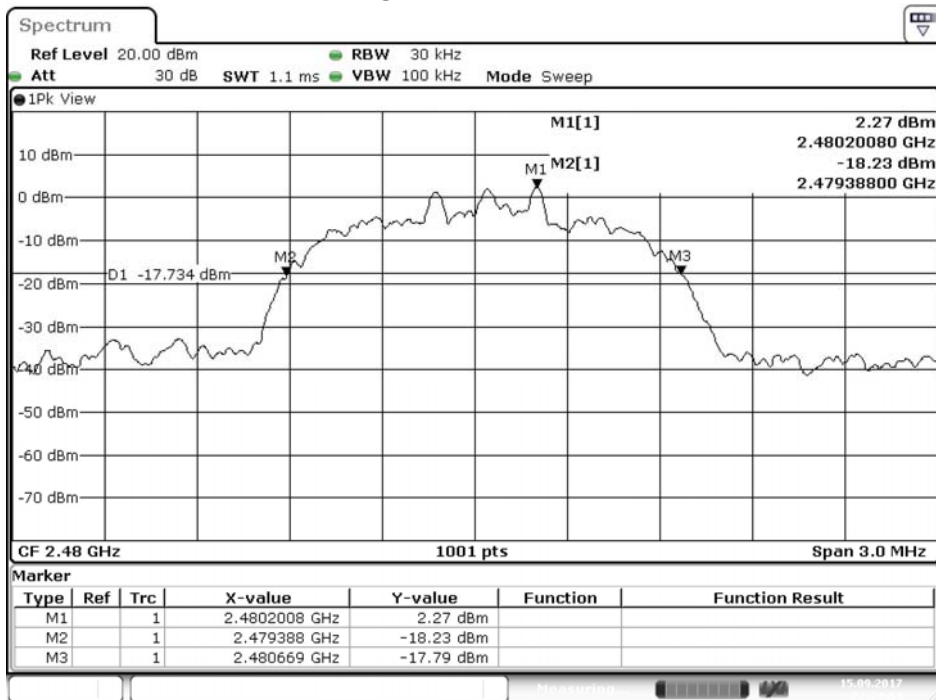

Date: 15.SEP.2017 22:29:55

---

**11. EMI Reduction Method During Compliance Testing**

No modification was made during testing.