



RADIO TEST REPORT

Test Report No. : 12193629S-G-R1

Applicant : TAIYO YUDEN CO., LTD.
Type of Equipment : Wireless LAN & Bluetooth Combo Module
Model No. : WYSAGVDXG, WYSEGVDXG
FCC ID : RYYWYSAGVDXG
Test regulation : FCC Part 15 Subpart E: 2018
Section 15.407 (DFS test only)
*Client without radar detection
Test Result : Complied (Refer to SECTION 4.2)

1. This test report shall not be reproduced in full or partial, without the written approval of UL Japan, Inc.
2. The results in this report apply only to the sample tested.
3. This sample tested is in compliance with the limits of the above regulation.
4. The test results in this test report are traceable to the national or international standards.
5. This test report must not be used by the customer to claim product certification, approval, or endorsement by any agency of the Federal Government.
6. This test report covers Radio technical requirements.
It does not cover administrative issues such as Manual or non-Radio test related Requirements. (if applicable)
7. The all test items in this test report are conducted by UL Japan, Inc. Shonan EMC Lab.
8. The opinions and the interpretations to the result of the description in this report are outside scopes where UL Japan has been accredited.
9. The information provided from the customer for this report is identified in SECTION 1.
10. This report is a revised version of 12193629S-G. 12193629S-G is replaced with this report.

Date of test : April 24, 2018

Representative test engineer:

Yosuke Ishikawa
Engineer
Consumer Technology Division

Approved by :

Akio Hayashi
Leader
Consumer Technology Division



- The testing in which "Non-accreditation" is displayed is outside the accreditation scopes in UL Japan.
 There is no testing item of "Non-accreditation".

UL Japan, Inc.
Shonan EMC Lab.

1-22-3 Megumigaoka, Hiratsuka-shi, Kanagawa-ken, 259-1220 JAPAN
Telephone: +81 463 50 6400
Facsimile: +81 463 50 6401

REVISION HISTORY

Original Test Report No.: 12193629S-G

Revision	Test report No.	Date	Page revised	Contents
-(Original)	12193629S-G	June 27, 2018	-	-
1	12193629S-G-R1	March 28, 2019	1	Addition of Comment “(Refer to SECTION 4.2)” “ 9. The information...”
			4	Addition of Comment “The information...” “(Information from test lab.)” Addition of Similar model Correction of Rating “Vmain: DC 3 V-3.6 V VIO: DC 5 V -> VIO : DC 1.8/ 3.3 V, VDD33 : DC 3.3 V”
			5	Correction of Antenna Gain “-0.1 dBi ->2.1 dBi” “4.4 dBi (1001932PT and 1001932FT), 2.2 dBi (AH104N2450D1) -> 4.5 dBi (1001932PT), 4.4 dBi (1001932FT), 2.4 dBi (AH104N2450D1)” Deletion of Comment “*EUT has two external antennas ...” “Refer to 12193629S-A and...”
			7	Addition of Comment “a), b) Refer to SECTION ...” “*1) Since measurement...”
			13	Addition of Item “H : Jig Board...” Addition of Comment “*1) VIO is converted...” Correction of Diagram

CONTENTS	PAGE
SECTION 1: Customer information	4
SECTION 2: Equipment under test (E.U.T.)	4
SECTION 3: Scope of Report	6
SECTION 4: Test specification, procedures & results	6
SECTION 5: Operation of E.U.T. during testing.....	12
SECTION 6: In-Service Monitoring for Channel Move Time, Channel Closing Transmission Time.....	17
SECTION 7: In-Service Monitoring for Non-Occupancy Period	19
APPENDIX 1: Data of DFS test.....	21
APPENDIX 2: Test instruments	22
APPENDIX 3: Photographs of test setup.....	23

SECTION 1: Customer information

Company Name : TAIYO YUDEN CO., LTD.
Address : 8-1 Sakae-cho Takasaki-shi Gunma 370-8522 Japan
Telephone Number : +81-27-324-2313
Facsimile Number : +81-27-324-2314
Contact Person : Masaki Naganuma

The information provided from the customer is as follows;

- Applicant, Type of Equipment, Model No., FCC ID on the cover and other relevant pages
- SECTION 1: Customer information
- SECTION 2: Equipment under test (E.U.T.)
- SECTION 4: Operation of E.U.T. during testing

* The laboratory is exempted from liability of any test results affected from the above information in SECTION 2 and 4.

SECTION 2: Equipment under test (E.U.T.)

2.1 Identification of E.U.T.

Type of Equipment : Wireless LAN & Bluetooth Combo Module
Model Number : WYSAGVDXG, WYSEGVDXG
Serial Number : Refer to Section 5.2
Rating : VIO : DC 1.8/ 3.3 V, VDD 33 : DC 3.3 V
Country of Mass-production : Japan
Condition of EUT : Engineering prototype
(Not for Sale: This sample is equivalent to mass-produced items.)
Receipt Date of Sample : March 14, 2018
(Information from test lab.)
Modification of EUT : The test lab did not make the modification to the EUT supplied from the customer to have it pass the tests.

2.2 Product description

Model: Wireless LAN & Bluetooth Combo Module (referred to as the EUT in this report) is a WYSAGVDXG, WYSEGVDXG.

Differences between WYSAGVDXG and WYSEGVDXG are as follows.

- WYSAGVDXG: Internal Antenna type (Chip Antenna)
- WYSEGVDXG: External Antenna type

Similar model : WYSAGVDXG-F, WYSEGVDXG-F

Radio Specification

Radio Type : Transceiver
Frequency of Operation : 2.4 GHz: 2402 MHz - 2480 MHz (Bluetooth BDR/EDR, Bluetooth Low Energy)
2412 MHz - 2462 MHz (IEEE 802.11b/g/11n-20)
2422 MHz - 2452 MHz (IEEE 802.11n-40)
U-NII-1 / 5180 MHz - 5320 MHz (IEEE 802.11a/n-20/ac-20)
U-NII- 5190 MHz - 5310 MHz (IEEE 802.11n-40/ac-40)
2A: 5210 MHz - 5290 MHz (IEEE 802.11ac-80)
U-NII- 5500 MHz - 5700 MHz (IEEE 802.11a/n-20/ac-20)
2C: 5510 MHz - 5670 MHz (IEEE 802.11n-40/ac-40)
5530 MHz - 5610 MHz (IEEE 802.11ac-80)
U-NII-3: 5745 MHz - 5825 MHz (IEEE 802.11a/n-20/ac-20)
5755 MHz - 5795 MHz (IEEE 802.11n-40/ac-40)
5775 MHz (IEEE 802.11ac-80)
Modulation : DSSS : IEEE 802.11b
OFDM : IEEE 802.11g/n/a/ac
FHSS(GFSK, /4-DQPSK, 8DPSK) : Bluetooth BDR/EDR
GFSK : Bluetooth Low Energy
Antenna type : [WYSAGVDXG] Chip Antenna (AH104N2450D1)
[WYSEGVDXG] External Antenna (1001932PT and 1001932FT)
Antenna Gain : 2.4 GHz: 2.5 dBi (1001932PT and 1001932FT), 2.1 dBi (AH104N2450D1)
5 GHz: 4.5 dBi (1001932PT), 4.4 dBi (1001932FT), 2.4 dBi (AH104N2450D1)
Operating Temperature : -30 deg. C to +85 deg. C
Clock frequency : 37.4 MHz

UL Japan, Inc. **Shonan EMC Lab.**

1-22-3 Megumigaoka, Hiratsuka-shi, Kanagawa-ken, 259-1220 JAPAN
Telephone: +81 463 50 6400
Facsimile: +81 463 50 6401

SECTION 3: Scope of Report

This report only covers DFS requirement, as specified by the following referenced procedures.

SECTION 4: Test specification, procedures & results

4.1 Test Specification

Test Specification	:	FCC Part 15 Subpart E FCC Part 15 final revised on March 12, 2018 and effective April 11, 2018
Title	:	FCC 47CFR Part15 Radio Frequency Device Subpart E Unlicensed National Information Infrastructure Devices Section 15.407 General technical requirements
Test Specification	:	KDB905462 D02 UNII DFS Compliance Procedures New Rules v02
Title	:	COMPLIANCE MEASUREMENT PROCEDURES FOR UNLICENSED- NATIONAL INFORMATION INFRASTRUCTURE DEVICES OPERATING IN THE 5250-5350MHz AND 5470-5725MHz BANDS INCORPORATING DYNAMIC FREQUENCY SELECTION
Test Specification	:	KDB905462 D03 Client Without DFS New Rules v01r02
Title	:	U-NII CLIENT DEVICES WITHOUT RADAR DETECTION CAPABILITY

FCC 15.31 (e) / 212

This EUT provides stable voltage constantly to RF Module regardless of input voltage from host device. Therefore, this EUT complies with the requirement.

FCC Part 15.203 / 212

[WYSAGVDXG]

It is impossible for end users to replace the antenna, because it is soldered on the circuit board. Therefore the equipment complies with the requirement.

[WYSEGVDXG]

The EUT has a unique coupling/antenna connector. Therefore the equipment complies with the requirement.

4.2 Procedures and results

Table 2: Applicability of DFS Requirements

Requirement	Operating Mode	Test Procedures & Limits *1)	Deviation	Results
	Client without Radar Detection			
U-NII Detection Bandwidth	Not required	FCC, KDB 905462 D02 Section 7.8.1	N/A	N/A
Initial Channel Availability Check Time	Not required	FCC15.407 (h)(2)	N/A	N/A
		FCC, KDB 905462 D02 Section 7.8.2.1		
		RSS-247 6.3		
Radar Burst at the Beginning of the Channel Availability Check Time	Not required	FCC15.407 (h)(2)	N/A	N/A
		FCC, KDB 905462 D02 Section 7.8.2.2		
		RSS-247 6.3		
Radar Burst at the End of the Channel Availability Check Time	Not required	FCC15.407 (h)(2)	N/A	N/A
		FCC, KDB 905462 D02 Section 7.8.2.3		
		RSS-247 6.3		
In-Service Monitoring for Channel Move Time, Channel Closing Transmission Time	Yes	FCC15.407 (h)(2)	N/A	Complied a)
		FCC, KDB 905462 D02 Section 7.8.3		
		RSS-247 6.3		
In-Service Monitoring for Non-Occupancy period	Yes *	FCC15.407 (h)(2)	N/A	Complied b)
		FCC, KDB 905462 D02 Section 7.8.3		
		RSS-247 6.3		
Statistical Performance Check	Not required	FCC15.407 (h)(2)	N/A	N/A
		FCC, KDB 905462 D02 Section 7.8.4		
Note: UL Japan, Inc.'s EMI Work Procedures No. 13-EM-W0422. *1) Since measurement was performed before issue of KDB 905462 D02 v02, we referred to KDB905462 D02. a) Refer to SECTION 6 (data of In-Service Monitoring for Channel Move Time, Channel Closing Transmission Time) b) Refer to SECTION 7 (data of In-Service Monitoring for Non-Occupancy Period)				

*Although this test was not required in FCC, KDB 905462 D02, it was performed as additional test.

UL Japan, Inc. Shonan EMC Lab.

1-22-3 Megumigaoka, Hiratsuka-shi, Kanagawa-ken, 259-1220 JAPAN
Telephone: +81 463 50 6400
Facsimile: +81 463 50 6401

Table 3: DFS Detection Thresholds for Master Devices and Client Devices With Radar

Maximum Transmit Power	Value (See Notes 1, 2 and 3)
E.I.R.P. \geq 200 milliwatt	-64 dBm
E.I.R.P. < 200 milliwatt and power spectral density < 10dBm/MHz	-62 dBm
E.I.R.P. < 200 milliwatt that do not meet the power spectral density requirement	-64 dBm
<p>Note 1: This is the level at the input of the receiver assuming a 0 dBi receive antenna.</p> <p>Note 2: Throughout these test procedures an additional 1 dB has been added to the amplitude of the test transmission waveforms to account for variations in measurement equipment. This will ensure that the test signal is at or above the detection threshold level to trigger a DFS response.</p> <p>Note 3: E.I.R.P. is based on the highest antenna gain. For MIMO devices refer to KDB Publication 662911 D01.</p>	

Table 4: DFS Response Requirement Values

Parameter	Value
Non-occupancy period	Minimum 30 minutes
Channel Availability Check Time	60 seconds
Channel Move Time	10 seconds See Note 1
Channel Closing Transmission Time	200 milliseconds + an aggregate of 60 milliseconds over remaining 10 second period. See Notes 1 and 2
U-NII Detection Bandwidth	Minimum 100 % of the U-NII 99 % transmission power bandwidth See Note 3
<p>Note 1: The Channel Move Time and the Channel Closing Transmission Time should be performed with Radar Type 0. The measurement timing begins at the end of the Radar Type 0 burst.</p> <p>Note 2: The Channel Closing Transmission Time is comprised of 200 milliseconds starting at the beginning of the Channel Move Time plus any additional intermittent control signals required to facilitate a Channel move (an aggregate of 60 milliseconds) during the remainder of the 10 second period. The aggregate duration of control signal will not count quiet periods in between transmissions.</p> <p>Note 3: During the U-NII Detection Bandwidth detection test, radar type 0 should be used. For each frequency step the minimum percentage of detection is 90 percent. Measurements are performed with no data traffic.</p>	

Table 5 Short Pulse Radar Test Waveform

Radars Type	Pulse Width [μs]	PRI [μs]	Number of Pulses	Minimum Percentage of Successful Detection	Minimum Number of Trials
0	1	1428	18	See Note 1	See Note 1
1	1	Test A: 15 unique PRI values randomly selected from the list of 23 PRI values in Table 5a	Roundup ((1 / 360) x ((19 x 10 ⁶) / PRI [micro sec.]))	60 %	30
		Test B: 15 unique PRI values randomly selected within the range of 518 - 3066 micro sec., with a minimum increment of 1 micro sec., excluding PRI values selected in Test A			
2	1 - 5	150 - 230	23 - 29	60 %	30
3	6 - 10	200 - 500	16 - 18	60 %	30
4	11 - 20	200 - 500	12 - 16	60 %	30
Aggregate (Rader Types 1-4)				80 %	120
Note 1: Short Pulse Radar Type 0 should be used for the detection bandwidth test, channel move time, and channel closing time tests.					

UL Japan, Inc.
Shonan EMC Lab.

1-22-3 Megumigaoka, Hiratsuka-shi, Kanagawa-ken, 259-1220 JAPAN
Telephone: +81 463 50 6400
Facsimile: +81 463 50 6401

Table 5a Pulse Repetition Interval Values for Test A

Pulse Repetition Frequency Number	Pulse Repetition Frequency (Pulses Per Second)	Pulse Repetition Interval (Micro seconds)
1	1930.5	518
2	1858.7	538
3	1792.1	558
4	1730.1	578
5	1672.2	598
6	1618.1	618
7	1567.4	638
8	1519.8	658
9	1474.9	678
10	1432.7	698
11	1392.8	718
12	1355	738
13	1319.3	758
14	1285.3	778
15	1253.1	798
16	1222.5	818
17	1193.3	838
18	1165.6	858
19	1139	878
20	1113.6	898
21	1089.3	918
22	1066.1	938
23	326.2	3066

Table 6 Long Pulse Radar Test Waveform

Radar Type	Pulse Width [μs]	Chip Width [MHz]	PRI [μs]	Number of Pulses per Burst	Number of Burst	Minimum Percentage of Successful Detection	Minimum Number of Trials
5	50 - 100	5 - 20	1000 - 2000	1 - 3	8 - 20	80 %	30

Table 7 Frequency Hopping Radar Test Waveform

Radar Type	Pulse Width [μs]	PRI [μs]	Pulse per Hop [kHz]	Hopping Rate [kHz]	Hopping Sequence Length [ms]	Minimum Percentage of Successful Detection	Minimum Number of Trials
6	1	333	9	0.333	300	70 %	30

4.3 Addition to standard

No addition, exclusion nor deviation has been made from the standard.

4.4 Test Location

UL Japan, Inc. Shonan EMC Lab.
1-22-3, Megumigaoka, Hiratsuka-shi, Kanagawa-ken 259-1220 JAPAN
Telephone number : +81 463 50 6400
Facsimile number : +81 463 50 6401
JAB Accreditation No. : RTL02610
FCC Test Firm Registration Number: 839876

	IC Registration No.	Width x Depth x Height (m)	Size of reference ground plane (m) / horizontal conducting plane	Maximum measurement distance
<input type="checkbox"/> No.1 Semi-anechoic chamber	2973D-1	20.6 x 11.3 x 7.65	20.6 x 11.3	10 m
<input type="checkbox"/> No.2 Semi-anechoic chamber	2973D-2	20.6 x 11.3 x 7.65	20.6 x 11.3	10 m
<input type="checkbox"/> No.3 Semi-anechoic chamber	2973D-3	12.7 x 7.7 x 5.35	12.7 x 7.7	5 m
<input type="checkbox"/> No.4 Semi-anechoic chamber	-	8.1 x 5.1 x 3.55	8.1 x 5.1	-
<input type="checkbox"/> No.1 Shielded room	-	6.8 x 4.1 x 2.7	6.8 x 4.1	-
<input type="checkbox"/> No.2 Shielded room	-	6.8 x 4.1 x 2.7	6.8 x 4.1	-
<input type="checkbox"/> No.3 Shielded room	-	6.3 x 4.7 x 2.7	6.3 x 4.7	-
<input type="checkbox"/> No.4 Shielded room	-	4.4 x 4.7 x 2.7	4.4 x 4.7	-
<input checked="" type="checkbox"/> No.5 Shielded room	-	7.8 x 6.4 x 2.7	7.8 x 6.4	-
<input type="checkbox"/> No.6 Shielded room	-	7.8 x 6.4 x 2.7	7.8 x 6.4	-
<input type="checkbox"/> No.8 shielded room	-	3.45 x 5.5 x 2.4	3.45 x 5.5	-
<input type="checkbox"/> No.1 Measurement room	-	2.55 x 4.1 x 2.5	-	-

4.5 Uncertainty

The following uncertainties have been calculated to provide a confidence level of 95 % using a coverage factor $k = 2$.

Time Measurement uncertainty for this test was: (\pm) 0.012 %

4.6 Test set up, Data of DFS test, and Test instruments of DFS

Refer to APPENDIX.

SECTION 5: Operation of E.U.T. during testing

5.1 Operating Modes

The EUT, which is a Client Device without Radar detection capability, operates over the 5260 MHz - 5320 MHz and 5500 MHz - 5700 MHz.

The EUT uses one transmitter connected to a 50 ohm coaxial antenna ports. The antenna port is connected to the test system.

WLAN traffic is generated by the software to ping from the Master to the Client. That software has random ping intervals. (Channel loading was over 17 %)

Software name & version: ExPing Version 1.33. We made six programs running at the same time and let them test sample has been communication to AP.

The EUT utilizes the 802.11a, 802.11n and 802.11ac architecture, with a nominal channel bandwidth (20 MHz, 40 MHz and 80 MHz).

The EUT had used IEEE 802.11ac-80 (widest mode).

The FCC ID for the Master Device used with EUT for DFS testing is LDK102087.

The IC Number for the Master Device used with EUT for DFS testing is 2461B-102087.

The rated output power of the Master unit is > 200 mW (23 dBm). Therefore the required interference threshold level is -64 dBm. After correction for antenna gain and procedural adjustments, the required conducted threshold at the antenna port is $-64 + 1 + 4 = -59$ dBm (threshold level + additional 1 dB + antenna gain *1)).

*1) Minimum antenna gain of the Master Device (FCC ID: LDK102087, IC No. 2461B-102087)

It is impossible for users to change DFS control, because the DFS function is written on the firmware and users cannot access it.

UL Japan, Inc.

Shonan EMC Lab.

1-22-3 Megumigaoka, Hiratsuka-shi, Kanagawa-ken, 259-1220 JAPAN

Telephone: +81 463 50 6400

Facsimile: +81 463 50 6401

5.2 Configuration and peripherals

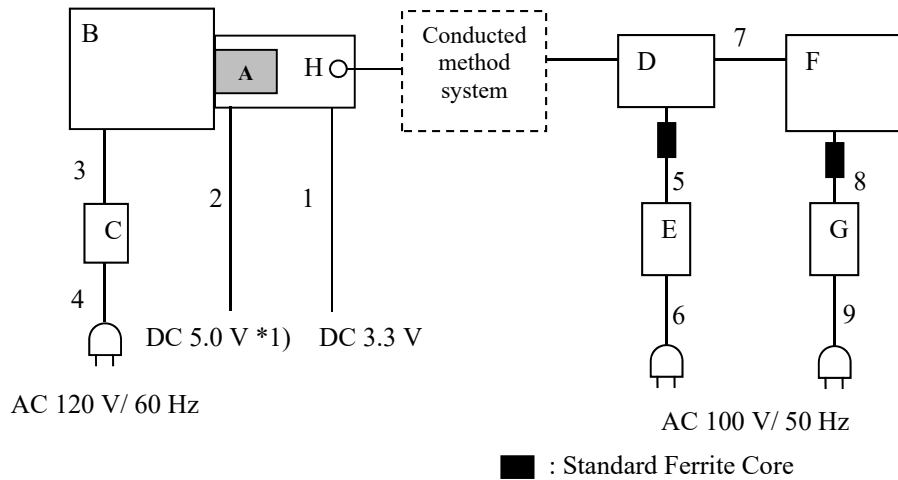

*1) DC 5.0 V is converted to DC 3.3 V on Jig Board and supplied to EUT

Description of EUT and Support equipment

No.	Item	Model number	Serial number	Manufacturer	Remarks
A	Wireless LAN & Bluetooth Combo Module	WYSEGVDXG *	TYWLAN-AC3FA4001B7D	TAIYO YUDEN CO., LTD.	
B	Laptop PC	X230	-	Lenovo	-
C	AC adaptor	45N0121	11S45N0121Z1ZHX U2A7B1Y	Lenovo	-
D	Wireless LAN access point (Master Device)	AIR-CAP3702E-A-K9	FTX18227609	Cisco Systems	
E	AC Adapter	AA25480L	ALD02510FEW	Cisco Systems	-
F	Laptop PC	LATITUDE D530	CN-0HP728-48643-83R-0675	Dell	-
G	AC Adapter	FA65NS0-00	CN-0YT886-73245-83R-2744	Dell	-
H	Jig Board	-	-	TAIYO YUDEN CO., LTD.	-

* The difference between WYSEGVDXG and WYSAGVDXG is the antenna (External or built-in). Therefore, the test was performed with WYSEGVDXG as a representative.

List of cables used

No.	Cable Name	Length (m)	Shield	
			Cable	Connector
1	DC cable	1.0	Unshielded	Unshielded
2	DC cable	1.0	Unshielded	Unshielded
3	DC cable	1.7	Unshielded	Unshielded
4	AC cable	0.9	Unshielded	Unshielded
5	Access Point DC Power	1.8	Unshielded	Unshielded
6	Access Point AC Power	1.8	Unshielded	Unshielded
7	LAN	3.0	Unshielded	Unshielded
8	DELL PC DC Power	1.9	Unshielded	Unshielded
9	DELL PC AC Power	0.85	Unshielded	Unshielded

UL Japan, Inc. Shonan EMC Lab.

1-22-3 Megumigaoka, Hiratsuka-shi, Kanagawa-ken, 259-1220 JAPAN
Telephone: +81 463 50 6400
Facsimile: +81 463 50 6401

5.3 Test and Measurement System

SYSTEM OVERVIEW

The measurement system is based on a conducted test method.

The software selects waveform parameters from within the bounds of the signal type on a random basis using uniform distribution. The short pulse types 2, 3, and 4, the long pulse type 5, and the frequency hopping type 6 parameters are randomized at run-time.

The signal monitoring equipment consists of a spectrum analyzer with the capacity to display 8001 bins on the horizontal axis. A time-domain resolution of 2 ms/bin is achievable with a 16 seconds sweep time, meeting the 10 seconds short pulse reporting criteria. The aggregate ON time is calculated by multiplying the number of bins above a threshold during a particular observation period by the dwell time per bin, with the analyzer set to peak detection. A time-domain resolution of 3 ms/bin is achievable with a 24 seconds sweep time, meeting the 22 seconds long pulse reporting criteria and allowing a minimum of 10 seconds after the end of the long pulse waveform.

FREQUENCY HOPPING RADAR WAVEFORM GENERATING SUBSYSTEM

The first 100 frequencies are selected out of the hopping sequence of the randomized 475 hop frequencies. Only a *Burst* that has the frequency falling within the receiver bandwidth of the tested U-NII device is selected among those frequencies. (Frequency-domain simulation). The radar waveform generated at the start time of the selected *Burst* (Time-domain simulation) is download to the Signal Generator. If all of the randomly selected 100 frequencies do not fall within the receiver bandwidth of the U-NII device, the radar waveform is not used for the test.

CONDUCTED METHODS SYSTEM BLOCK DIAGRM

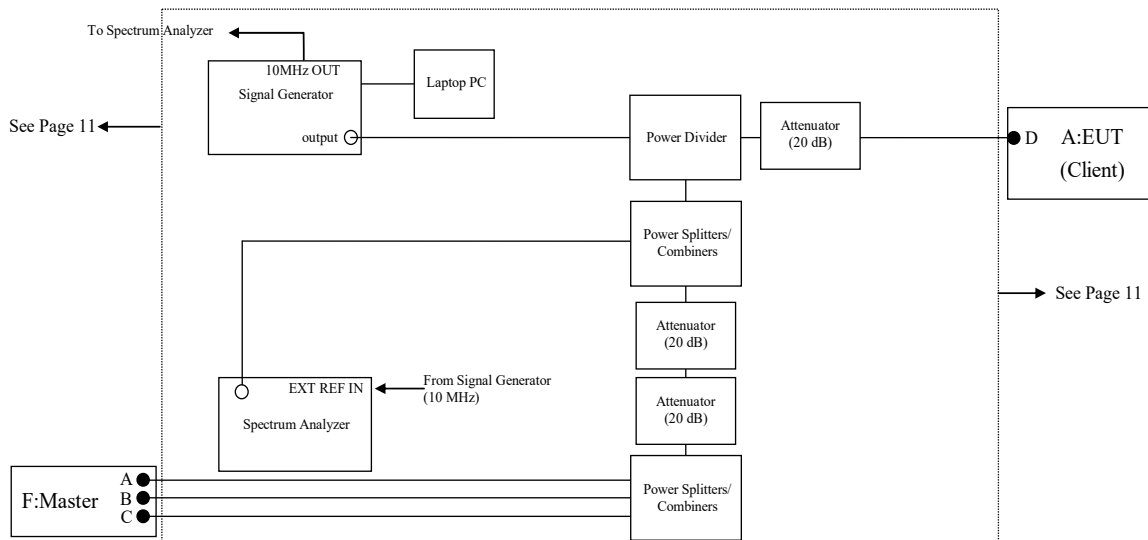

MEASUREMENT SYSTEM FREQUENCY REFERENCE

Lock the signal generator and the spectrum analyzer to the same reference sources as follows: Connect the 10 MHz OUT on the signal generator to the 10 MHz IN on the spectrum analyzer and set the spectrum analyzer 10 MHz In to On.

UL Japan, Inc.
Shonan EMC Lab.

1-22-3 Megumigaoka, Hiratsuka-shi, Kanagawa-ken, 259-1220 JAPAN
Telephone: +81 463 50 6400
Facsimile: +81 463 50 6401

SYSTEM CALIBRATION

Step 1: Set the system as shown in Figure 3 of FCC KDB 905462 section 7.2.2.

Step 2: Adjust each attenuator to fulfill the following three conditions:

- WLAN can be communicated, and
- Rader detection threshold level is bigger than Client Device traffic level on the spectrum analyzer, and
- Master Device traffic level is not displayed on the spectrum analyzer.

Step 3: Terminate 50 ohm at B and C points, and connect the spectrum analyzer to the point A.

(See the figure on page 12)

At the point A, adjust the signal generator and spectrum analyzer to the center frequency of the channel to be measured. Download the applicable radar waveforms to the signal generator. Select the radar waveform, trigger a burst manually and measure the amplitude on the spectrum analyzer. Readjust the amplitude of the signal generator as required so that the peak level of the waveform is at a displayed level equal to the required or desired interference detection threshold. Separate signal generator amplitude settings are determined as required for each radar type.

Step 4: Without changing any of the instrument settings, restore the system setting to Step 2 and adjust the Reference Level Offset of the spectrum analyzer to the level at Step 3.

By taking the above steps 1 to 4, the spectrum analyzer displays the level of the signal generator as received at the antenna ports of the Master Device.

See Clause 5.4 for Plots of Noise, Rader Waveforms, and WLAN signals.

5.4 Plots of Noise, Rader Waveforms, and WLAN signals

Plots of System Noise Floor

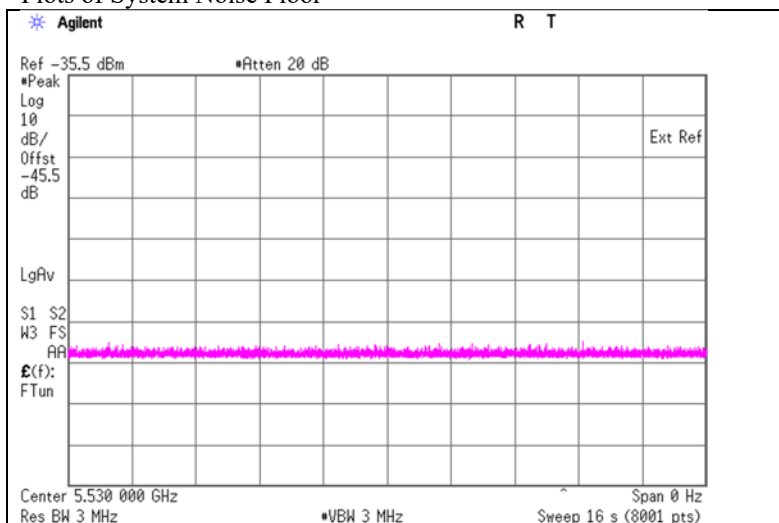

It was confirmed that the EUT did not transmit before having received appropriate control signals from a Master Device.

UL Japan, Inc. Shonan EMC Lab.

1-22-3 Megumigaoka, Hiratsuka-shi, Kanagawa-ken, 259-1220 JAPAN
Telephone: +81 463 50 6400
Facsimile: +81 463 50 6401

Plots of Radar Waveforms

Rader Type 0

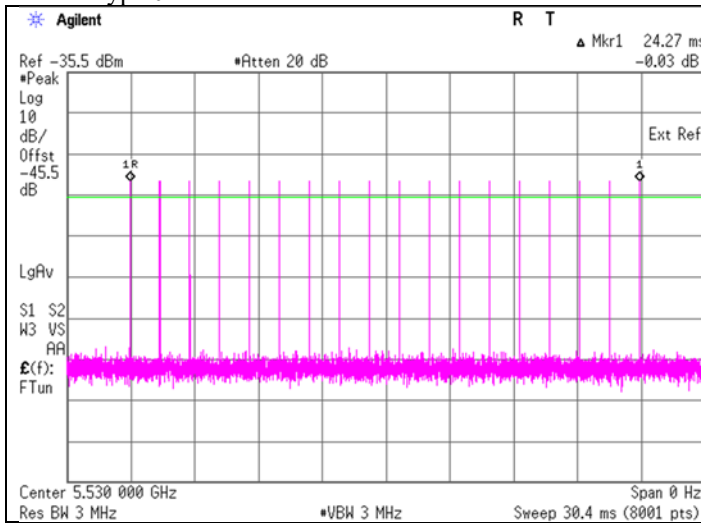

Plots of WLAN Traffic

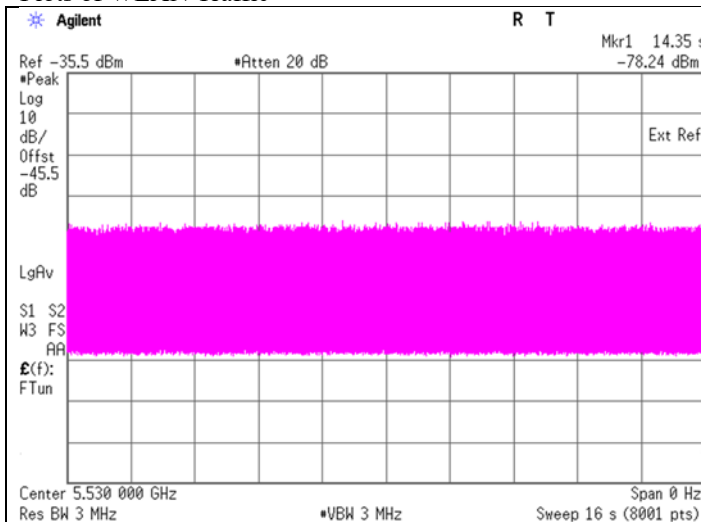

UL Japan, Inc.
Shonan EMC Lab.

1-22-3 Megumigaoka, Hiratsuka-shi, Kanagawa-ken, 259-1220 JAPAN
Telephone: +81 463 50 6400
Facsimile: +81 463 50 6401

SECTION 6: In-Service Monitoring for Channel Move Time, Channel Closing Transmission Time

6.1 Operating environment

Test place Shonan EMC Lab. No.5 Shielded Room
Date May 16, 2018
Temperature/ Humidity 25 deg. C / 52 % RH
Engineer Yosuke Ishikawa
Mode Communication 11ac-80

6.2 Test Procedure

Transfer files from the Master Device to the Client Device on the tested channel during the entire period of the test. The Radar Waveform generator sends a Burst of pulses for one of the Short Pulse Radar Types 1 - 4 at levels defined , on the Operating Channel. An additional 1 dB is added to the radar test signal to ensure it is at or above the DFS Detection Threshold, accounting for equipment variations/errors. Observe the transmissions of the EUT at the end of the radar Burst on the Operating Channel for duration greater than 10 seconds.

6.3 Test data

Test Item	Unit	Measurement Time	Limit	Results
Channel Move Time *1)	[s]	0.070	10.000	Pass
Channel Closing Transmission Time *2)	[ms]	0	60	Pass

*1) Channel Move Time is calculated as follows:

$$(\text{Channel Move Time}) = (\text{End of Transmission}) - (\text{End of Burst}) = 2.392 - 2.322$$

*2) Channel Closing Transmission Time is calculated from (End of Burst + 200 ms) to (End of Burst + 10 s)

$$(\text{Channel Closing Transmission Time}) = (\text{Number of analyzer bins showing transmission}) \times (\text{dwell time per bin}) \\ = 0 \times 2 \text{ [ms]}$$

Radar Type 0

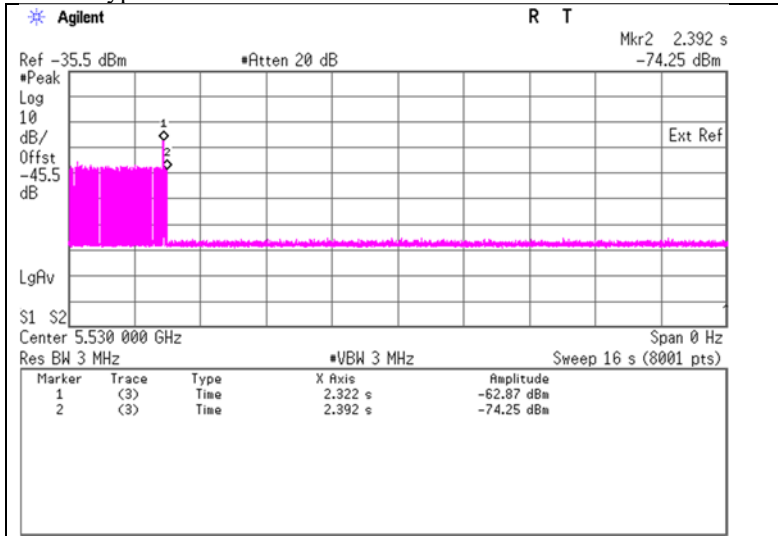

Marker 1: - End of Burst : 2.322 s
 Marker 2: - End of Transmission : 2.392 s

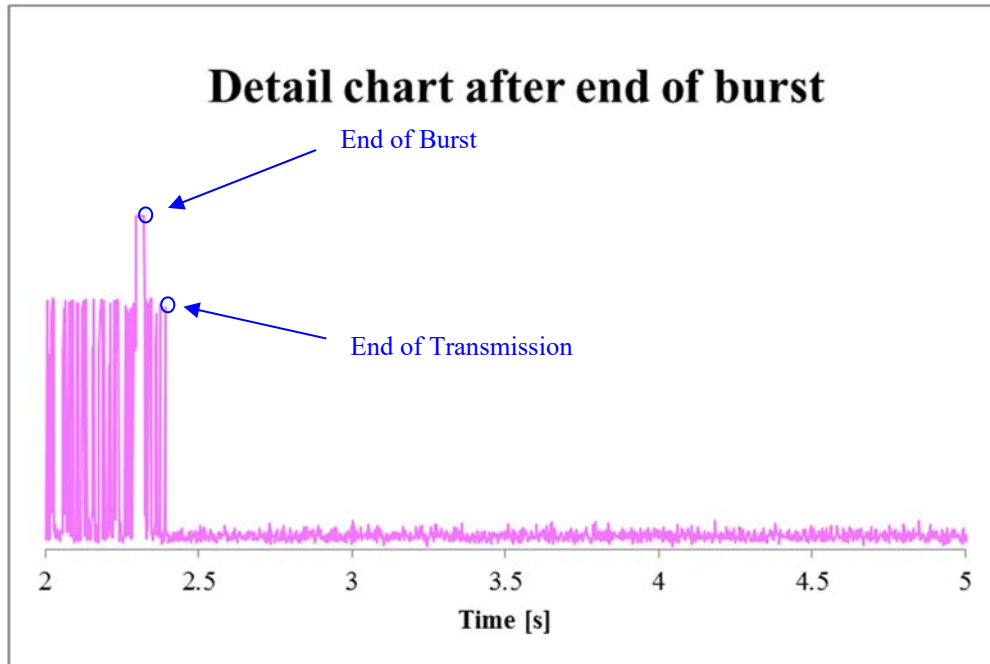

6.4 Test result

Test result: Pass

Date : May 16, 2018

Test engineer : Yosuke Ishikawa

SECTION 7: In-Service Monitoring for Non-Occupancy Period

7.1 Operating environment

Test place : Shonan EMC Lab. No.5 Shielded Room
Date : May 16, 2018
Temperature/ Humidity : 25 deg. C / 52 % RH
Engineer : Yosuke Ishikawa
Mode : Communication 11ac-80

7.2 Test Procedure

The following two tests are performed:

- 1). Transmit the data from the Master Device to the Client Device on the test Channel for the entire period of the test. The Radar Waveform generator sends a Burst of pulses for one of the Radar Types 0 at levels defined on the Operating Channel. An additional 1 dB is added to the radar test signal to ensure it is at or above the DFS Detection Threshold, accounting for equipment variations/errors. Observe the transmissions of the EUT after the Channel Move Time on the Operating Channel for duration greater than 30 minutes.
- 2). Transmit the data from the Master Device to the Client Device on the test Channel for the entire period of the test. Observe the transmissions of the EUT on the Operating Channel for duration greater than 30 minutes after the Master Device is shut off.

7.3 Test data

1).Radar Type 0

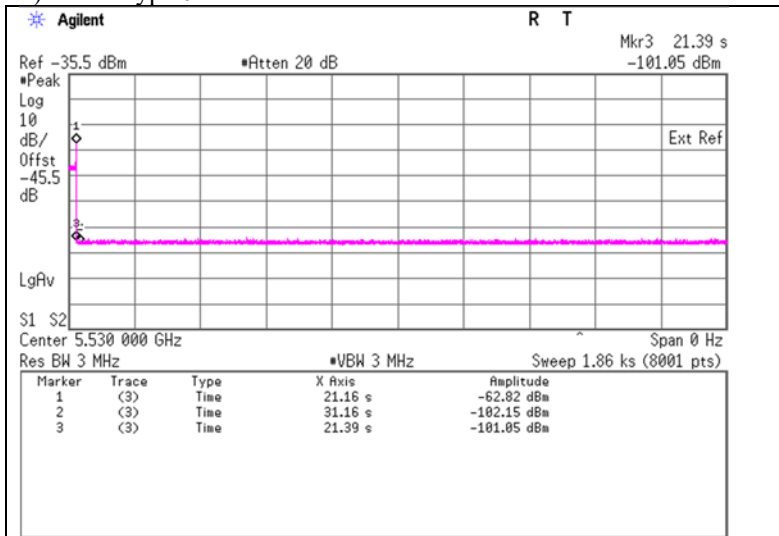

Marker 1 : End of Burst : 21.16 s
Marker 2 : End of Burst + 10 s : 31.16 s

* Measurement non-occupancy period: 30.64 minutes or more (1860 [s] – 21.39 [s] = 1838.61 [s] = 30.64 [minutes])

UL Japan, Inc.
Shonan EMC Lab.

1-22-3 Megumigaoka, Hiratsuka-shi, Kanagawa-ken, 259-1220 JAPAN
Telephone: +81 463 50 6400
Facsimile: +81 463 50 6401

2).Master is shut off

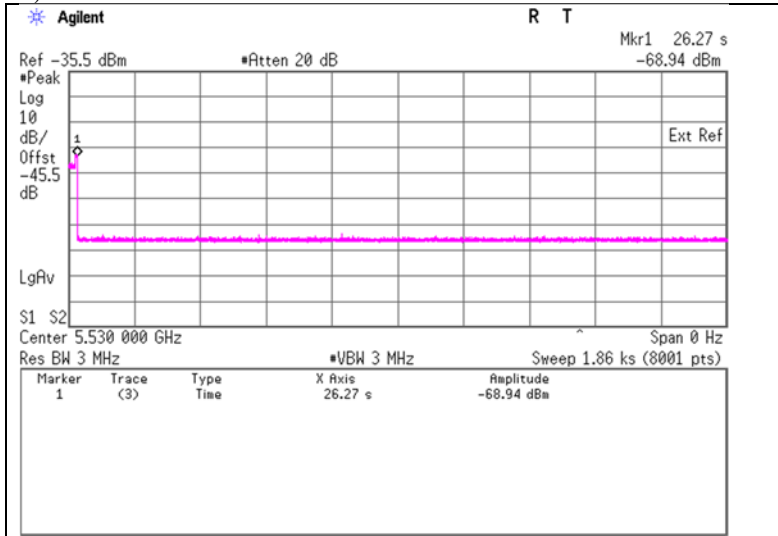

Marker 1 : End of Burst : 26.27 s

* Measurement non-occupancy period: 30.56 minutes or more (1860 [s] – 26.27 [s] = 1833.73 [s] = 30.56 [minutes])

7.4 Test result

Test result: Pass

Date : May 16, 2018

Test engineer : Yosuke Ishikawa

APPENDIX 1: Data of DFS test

Parameter Data for Radar Type 5

(for old rule KDB905462 D01)

Trial Number	Burst	Number of Pulses	Pulse Width [us]	Chirp Width [MHz]	Pulse 1-to-2 Spacing [us]	Pulse 2-to-3 Spacing [us]	Starting Location Within Interval [us]
1	1	1	52	8			64
1	2	2	94	7	1535		680793
1	3	3	67	8	1851	1146	452538
1	4	1	50	18			791967
1	5	3	82	14	1511	1064	61930
1	6	2	98	12	1125		95345
1	7	1	76	6			434356
1	8	1	64	16			720311
1	9	1	79	13			728383
1	10	1	61	15			194181
1	11	3	73	16	1638	1497	569650
1	12	2	95	11	1811		434312
1	13	2	50	19	1491		613325
1	14	3	58	13	1254	1098	431579

UL Japan, Inc.
Shonan EMC Lab.

1-22-3 Megumigaoka, Hiratsuka-shi, Kanagawa-ken, 259-1220 JAPAN

Telephone: +81 463 50 6400

Facsimile: +81 463 50 6401

APPENDIX 2: Test instruments

EMI Test Equipment

Control No.	Instrument	Manufacturer	Model No	Serial No	Test Item	Calibration Date * Interval(month)
SSA-02	Spectrum Analyzer	Agilent	E4448A	MY48250106	DFS	2018/03/05 * 12
SSG-13	Signal Genelator	Rohde & Schwarz	SMBV100A	262877	DFS	2017/08/18 * 12
SPSC-03	Power Splitters/Combiners	Mini-Circuits	ZFSC-2-10G+	-	DFS	2018/04/20 * 12
SPD-01	Power Divider	Agilent	11636B	56998	DFS	2018/04/20 * 12
SCC-G14	Coaxial Cable	Suhner	SUCOFLEX 102	31600/2	DFS	2018/03/19 * 12
SCC-G34	Coaxial Cable	Junkosha	MWX241- 01000KMSKMS/ B	1612Q032	DFS	2018/01/25 * 12
SCC-G35	Coaxial Cable	Junkosha	MWX241- 01000KMSKMS/ B	1612Q033	DFS	2018/01/25 * 12
SCC-G36	Coaxial Cable	Junkosha	MWX241- 01000KMSKMS/ B	1612Q034	DFS	2018/01/25 * 12
SAT20-07	Attenuator	Weinschel Corp.	54A-20	31484	DFS	2018/04/20 * 12
SAT20-12	Attenuator	Weinschel Corp.	54A-20	86752	DFS	2017/12/08 * 12
SAT20-13	Attenuator	Weinschel Corp.	54A-20	87636	DFS	2017/12/08 * 12
SPSC-04	Power Splitters/Combiners	Mini-Circuits	ZN4PD1-63-S+	-	DFS	2017/07/19 * 12
SCC-G24	Coaxial Cable	Suhner	141PE	-	DFS	2017/07/18 * 12
SCC-G25	Coaxial Cable	Suhner	141PE	-	DFS	2017/07/18 * 12
SCC-G26	Coaxial Cable	Suhner	141PE	-	DFS	2017/07/18 * 12

The expiration date of the calibration is the end of the expired month.

As for some calibrations performed after the tested dates, those test equipment have been controlled by means of an unbroken chains of calibrations.

All equipment is calibrated with valid calibrations. Each measurement data is traceable to the national or international standards.

Test Item :

DFS: Dynamic Frequency Selection

**UL Japan, Inc.
Shonan EMC Lab.**

1-22-3 Megumigaoka, Hiratsuka-shi, Kanagawa-ken, 259-1220 JAPAN

Telephone: +81 463 50 6400

Facsimile: +81 463 50 6401