

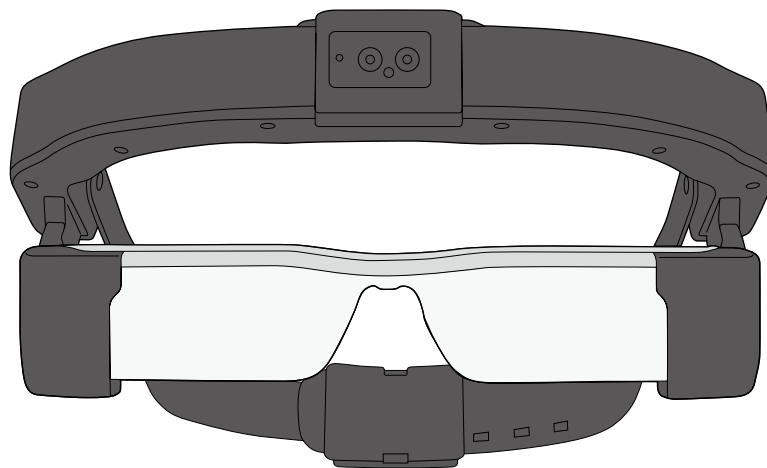

\*412999700\*





# User's Guide



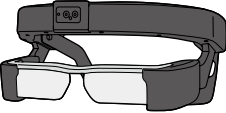

## Contents

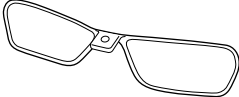
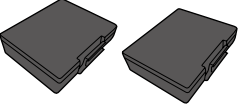
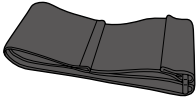
Included Items .....	2	Viewing Images Using the Headset.....	12
Optional Items.....	2	Maintenance .....	12
Safety Instructions.....	3	Troubleshooting.....	13
Part Names and Functions.....	6	Specifications.....	14
Getting Ready.....	8	Intellectual Property Rights.....	15
Turning On and Off .....	10	General Notes .....	15
Wearing the Product .....	10	Contact List .....	18

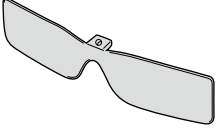
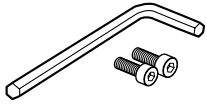
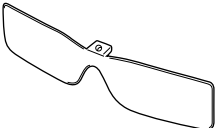
## Included Items

	<p><b>Headset</b> Wear the headset to view images. ➔ "Wearing the Headset" p. 11</p>		<p><b>Inner pads (A/B/C)</b> Attach inside the headset to adjust the headset to fit your head. The inner pad B is attached to the headset at the time of purchase. ➔ "Replacing the Inner Pad" p. 9</p>
	<p><b>Controller (with controller holder)</b> Operates the product.</p>		<p><b>Lens holder</b> Install lenses and attach them to the headset. This allows users who wear glasses to remove their glasses before wearing the headset. ➔ "Installing the Shade/Protective Shield/Lens Holder" p. 9</p>
	<p><b>Battery packs (x2)</b> Powers the product. ➔ "Charging the Battery" p. 8</p>		<p><b>Armband</b> Allows you to wear the controller on your arm. ➔ "Wearing the Controller" p. 10</p>
	<p><b>AC adapter/AC cable</b> Charges the product. The AC cable connector shape differs depending on where you bought the product. ➔ "Charging the Battery" p. 8</p>		<p><b>Mono earphones with mic</b> Outputs audio from the product, and inputs audio to the product.</p>
	<p><b>Shade</b> Shades the product from too much exterior light. ➔ "Installing the Shade/Protective Shield/Lens Holder" p. 9</p>		<p><b>Hexagon wrench and screws (x2)</b> Attaches the lens holder, shade, and protective shield.</p>
	<p><b>Protective shield</b> Protects the product's lens from foreign objects. ➔ "Installing the Shade/Protective Shield/Lens Holder" p. 9</p>		

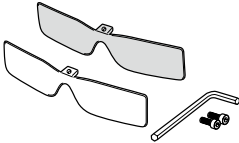
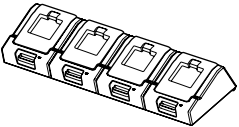
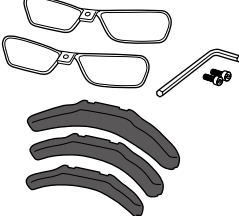
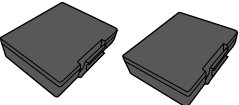
## Optional Items



	<p><b>Hard carrying case</b> BO-HC2000 Use this case when carrying or storing the product.</p>		<p><b>Shade*/Protective shield*</b> BO-SD2000</p>
	<p><b>Quad battery charger</b> BO-QC2000 Allows you to charge four battery packs simultaneously. The battery packs are not included.</p>		<p><b>Inner pads (A/B/C)*/Lens holders* (x2)</b> BO-IP2000</p>
	<p><b>Battery packs* (x2)</b> BO-BP2000</p>		<p><b>Controller holder*/Armband*</b> BO-PW2000</p>

\* Included with the product at time of purchase.

## Safety Instructions

For your safety, read the attached documents carefully to use the product correctly. After you have read the documents, save them for later reference.

### Safety symbols

 <b>Warning</b>	This symbol indicates information that, if ignored, could possibly result in serious personal injury or even death due to incorrect handling.
 <b>Caution</b>	This symbol indicates information that, if ignored, could possibly result in personal injury or physical damage due to incorrect handling.

### **Warning Usage environment and condition precautions**

Only use this product at the stated power-supply voltage.

Only use the supplied AC cable and AC adapter. Using other power supply devices could result in heat, fire, explosion, malfunction, or liquid leakage.

Take the following precautions when handling the plug. Failure to comply with these precautions could result in fire or electric shock.

- Do not plug the AC adapter into an outlet being used by many other devices.
- Do not insert the plug into a dusty outlet.
- Insert the plug firmly into the outlet.
- Do not hold the plug with wet hands.
- Do not pull the power cable when disconnecting the plug.

Do not use the supplied power cable if it is damaged. Doing so could result in fire or electric shock.

- Do not modify the supplied power cable.
- Do not place heavy objects on top of the supplied power cable.
- Do not bend, twist, or pull the power cable with excessive force.
- Keep the power cable away from hot electrical appliances.

For your safety, unplug the product when it is not being used. The insulation may deteriorate, which may result in electric shock, fire, or malfunction.

Do not touch the plug during a thunderstorm. Doing so could result in fire or electric shock.



Do not leave this product in locations subject to temperatures beyond the specified operating range, such as cars with the windows closed, in direct sunlight, or in front of air-conditioning or heater outlets. Also, avoid locations subject to sudden changes in temperature. Doing so may result in deformation due to heat, fire, malfunction, failure, or damage.

Do not use the product in locations where it may get wet or is subject to high levels of humidity such as in a bath or shower. Doing so could result in fire or electric shock.

Do not place this product in locations subject to smoke, steam, high humidity, or dust such as kitchen counters or near humidifiers. Doing so may result in fire, electric shock, or deterioration in image quality.

Do not cover this product with a cloth or similar material during use. Doing so may change the shape of the case through heat, or fire.

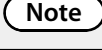
### General information symbols

 <b>Caution</b>	Indicates procedures which may result in damage or injury if sufficient care is not taken.
 <b>Note</b>	Indicates additional information and points which may be useful to know regarding a topic.
[ ]	Indicates controller keys and icons and menu items displayed on the screen.
	Indicates a reference to related topics.

Do not expose the camera lens to direct sunlight for a long time. Doing so may result in fire or explosion due to condensed beams of light from the lens.

### **Warning Product usage precautions**

 Do not start using this product at a high volume. Doing so may result in hearing impairment. Lower the volume before turning off the product, and gradually increase the volume after turning on the product. To prevent possible hearing damage, do not listen at high volume for prolonged periods of time.

Do not allow any conductive foreign objects to touch the charging connector, external device connector, or earphone microphone socket, and do not put any conductive foreign objects into the connection ports. Doing so may cause a short circuit and result in fire or electric shock.

Do not allow solvents such as alcohol, benzene, or thinner to touch the product. Also, do not clean this product with a wet cloth or solvents. Doing so may warp or crack the product housing and may result in electric shock, malfunction, or fire.

The product housing should only be opened by qualified service personnel unless you are explicitly instructed to do so in the User's Guide. Also, do not disassemble or remodel the product (including consumable items). Many of the parts inside the product carry a high voltage and could cause fire, electric shock, accident, or poisoning.

Do not subject the lens of the product to strong shocks or knock it against hard objects. If the lens is damaged, it could splinter and cause serious injuries to the eyes and face.

Do not throw the product into a fire and do not heat the product. Do not place objects with naked flames, such as candles, on this product. Doing so may result in heat, fire, or explosion.

### **Warning Viewing image precautions**

Do not wear this product while driving a car, riding a motor bike or bicycle, cooking, or performing any other dangerous tasks. Doing so may result in accident or injury.

Do not use this product in unstable locations such as stairs or at altitude. Also, do not use the product while walking in dangerous locations such as near machinery or equipment that might get caught on the cables, where there is a lot of traffic, or where it is dark. Doing so may result in accident or injury.

When walking while viewing images on the product, be aware of your surroundings. If you are too focused on the image, it could result in ac-

## Safety Instructions

idents, falling down, and colliding with other people. Slide up the lens whenever possible so as not to impede your vision.

When viewing in dark locations, it is difficult to see your surroundings due to the brightness of the image. Be aware of your surroundings.

When using this product in small locations, be aware of your surroundings.

When wearing this product, do not look directly at the sun or other light sources even if you are using the shade. This could cause serious injury to your eyes or loss of eyesight.

Make sure the cable does not catch on anything in the surrounding area while wearing the product. Also, make sure the cable does not wind around your neck. Doing so may result in accident or injury.

Make sure the cable does not get damaged. Otherwise, it may result in fire or electric shock.

- Do not damage the cable.
- Do not place heavy objects on top of the cable.
- Do not bend, twist, or pull the cable with excessive force.
- Keep the power cable away from hot electrical appliances.

### **Warning Product abnormality precautions**

In the following situations, turn off this product immediately, unplug the power plug, and contact your local dealer or the Epson service call center. Continuing to use under these conditions may result in fire or electric shock. Do not try to repair this product yourself.

- If you see smoke, or notice any strange odors or noises.
- If any water, beverages, or foreign objects get into the product.
- If the product was dropped or the case was damaged.

### **Warning Wireless function precautions**

When taking this product into areas in which the use of electromagnetic waves is prohibited, such as in an aircraft or in hospitals, follow the instructions in the area and turn off this product or disable the Bluetooth or wireless LAN function. Do not use the Bluetooth or wireless LAN function near automatically controlled devices such as automatic doors or fire alarms. If the product has an auto power on function, disable it before turning off the product. The electromagnetic waves may cause electromagnetic interference with medical equipment or cause the equipment to malfunction.

Note the following points when using the Bluetooth or wireless LAN function in medical institutions.

- Do not bring this product into operating rooms, Intensive Care Units (ICUs), or Cardiac Care Units (CCUs).
- When on wards, turn off this product or stop the electromagnetic waves.
- Even when not on wards, turn off this product or stop the electromagnetic waves if there is any electronic medical equipment in the area.
- Follow any rules stipulated by medical institutions that prohibit the use of devices emitting electromagnetic waves, or that prohibit entry to certain areas with such devices.
- If the product has an auto power on function, disable it before turning off the product.

If you have an implanted pacemaker or implanted defibrillator, make sure you keep a distance of at least 22 cm between this product and

the implanted device when using the Bluetooth or the wireless LAN function. The electromagnetic waves may influence the operation of implanted pacemakers or implanted defibrillators. Turn off this product or stop the electromagnetic waves if you are in a location where someone near you may have a pacemaker, such as a crowded train.

### **Caution Usage environment and condition precautions**

Do not place the product in locations subjected to vibrations or shocks.

While viewing images using the product, make sure you confirm the safety of your surroundings and do not leave any fragile items in your immediate vicinity. The images you are viewing may cause you to move your body involuntarily, resulting in damage to nearby items or personal injury.

Do not place this product near high-voltage lines or magnetized items. Doing so may result in breakdown, malfunction, or failure.

When performing maintenance, make sure you turn off the product, unplug the power plug and the power connector and disconnect all wires. Otherwise, it may result in electric shock.

Stop charging the battery if the charging does not end in the stated period of time. Continuing the charge may result in liquid leakage, heat, explosion, or fire.

If the batteries are not handled correctly, the battery could explode or leak which could cause a fire, injury, and corrode the product. Take the following precautions to make sure you use this product safely.

- Do not use different types of batteries at the same time, and do not use a mixture of old and new batteries.
- Do not use any batteries other than those specified in the User's Guide.
- If the battery leaks, wipe up the leaked liquid with a cloth and replace it with a new battery (if any leaked liquid gets on your hands, wash in water immediately).
- Immediately remove batteries when it is time to replace them.
- Remove the batteries if you will not be using the product for a while.
- Do not heat the batteries or throw them into fire or water.

### **Caution Product usage precautions**

Do not over tighten the head band while wearing the product. Doing so may result in injury or rash due to the pressure.

Stop using this product if the skin that touches the product (head, face, and so on) feels itchy when wearing the product, or any unusual rashes occur, and consult your local dermatologist.

If you sweat while using the product, wipe the sweat from your head, face, and the product. Continuing to use under these conditions may result in itching or a rash.

Hold the controller securely or place it on a stable surface and make sure the cables are not pulled with undue force. Dropping the headset due to the weight of the controller may result in injury or malfunction.

Dispose of this product in accordance with your local laws and regulations.

## **Caution Viewing image precautions**

Always take periodic breaks when viewing images using this product. Long periods of viewing images may result in eye fatigue. If you feel fatigued or uncomfortable even after taking a break, stop viewing immediately.

Do not drop this product or treat it with unnecessary force. Also, if the product breaks due to an impact such as a fall, stop using the product. Continuing to use this product may result in injury due to glass fragments.

Do not place your finger between the moving parts of this product, such as the hinges. Doing so may result in injury.

Make sure you are wearing this product correctly. Incorrect usage could make you feel nauseous.

This product should only be used for the purposes stated in the manuals. Using it for anything else may result in injury.

If a problem or malfunction occurs, stop using this product immediately. Continuing to use this product may result in injury or could make you feel nauseous.

Stop using this product if your skin feels unusual when wearing this product and consult your local dermatologist. Sometimes allergies may occur due to the coating or material of the product.

How a 3D image is perceived varies depending on the individual. Stop using the 3D function if you feel strange or cannot see in 3D. Continuing to view the 3D images could make you feel nauseous.

Children (especially under elementary school age) should not use this product as their eyesight is still developing.

Do not use this product if you are sensitive to light, or feel nauseous. Doing so may aggravate your pre-existing conditions.

Do not use this product if you have prior eye conditions. Doing so may aggravate the symptoms such as strabismus, amblyopia, or anisometropia.

## **Caution Product abnormality precautions**

Data such as video or images stored on the product may be lost or damaged when the product malfunctions, is repaired, or undergoes other services. Epson shall not be responsible for the loss of any data, damage to data, or loss of profits that occurs at such a time.



You can recycle used lithium-ion batteries. When the product's internal battery reaches the end of its service life, contact a service center for information on recycling.

## **Dust-proofing and Water-proofing**

When the product's battery cover and port covers are installed correctly, the product is dust-proof and water-proof compliant with IP54 standard based on JISC0920 (IEC60529:2001) confirmed by tests from a third party.

The dust-proof and water-proof features do not guarantee that the product will operate under all conditions or protect against malfunctions. The warranty is invalid if malfunctions are determined to have occurred due to incorrect handling of the product by the user.

### **Dust-proofing level compliant with IP5X**

- This prevents dust from getting inside the product.
- Even if a small amount of dust does enter the product, it can still be operated normally.

### **Water-proofing level compliant with IPX4**

If the product is subjected to water at a normal temperature from a faucet at a rate of 10 L/min for over five minutes, water does not enter the product and it can be operated normally.

## **Caution Dust-proofing and water-proofing precautions**

When using the product, remove all connected cables, and close the battery cover, AC adapter port cover and micro USB port cover securely. When you open these covers for battery replacement or other purposes, open it in location away from water or dust and do not handle with wet hands. If tiny pieces of trash such as hairs or sand become inserted between the ports, this may allow water or dust to enter the product. When the power cable or the microUSB cable are connected to the product, the dust-proof and water-proof performance is not maintained.

Do not drop or damage the product. This could cause the dust-proof and water-proof performance to degrade.

Do not peel off or damage the rubber packing on the back of each cover. Do not allow trash to stick to the rubber packing. This could cause the dust-proof and water-proof performance to degrade.

Do not allow other liquids (such as organic solvents, soapy water, hot spring water, and seawater) to splash onto the product, and do not place it in water intentionally.

Do not leave the product in locations subject to humidity such as bathrooms.

Do not use the product in heavy rain.

If rain or water splash onto the product, wipe it with a dry cloth as soon as possible.

## Headset

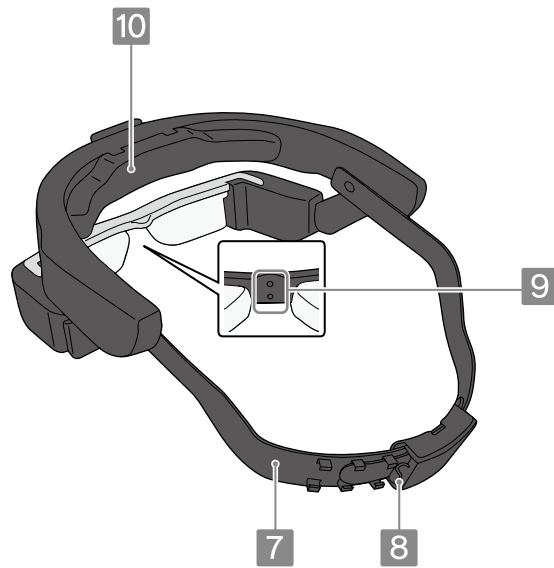
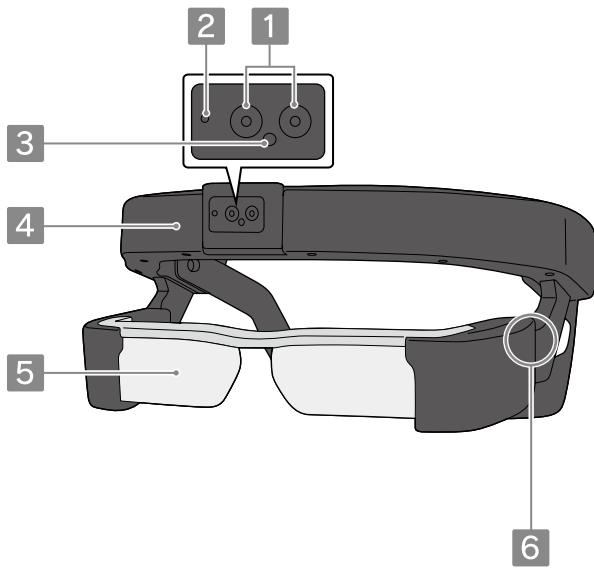

### 1 Camera

Captures images and movies. Remove the protective film before using the camera. You can adjust the direction of the camera vertically.

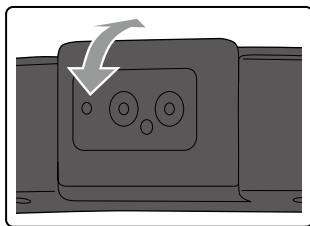

### 2 Camera indicator

Flashes while the camera is operating.

### 3 Light sensor

Senses the brightness of your surroundings and automatically adjusts the brightness of the screen.

### 4 Head pad

Fits against your forehead when wearing the headset. The head pad is equipped with a built-in sensor to detect the position and direction of the product.

### 5 Lens

Displays images. When you are not viewing images, you can slide up the lens to the head pad.

➔ "Viewing Images Using the Headset" p. 12

### 6 Lens justifier

You can adjust the position of the lens vertically. Make sure the lens is level when adjusting.

### 7 Head band

Secures the headset on to your head. You can adjust the length to fit the size of your head (head circumference: 560 to 640 mm).

### 8 Cable securer

Secures cables when wearing the headset.

### 9 Screw holes to secure the shade/protective shield/lens holder

Install the shade/protective shield using the exterior screw holes. Install the lens holder using the interior screw holes.

➔ "Installing the Shade/Protective Shield/Lens Holder" p. 9

### 10 Inner pad (B)

If the headset feels tight, replace this with inner pad A or C. The headset feels loose if you attach a smaller inner pad.

➔ "Replacing the Inner Pad" p. 9

# Controller

The illustrations show the controller when it has been removed from the controller holder.

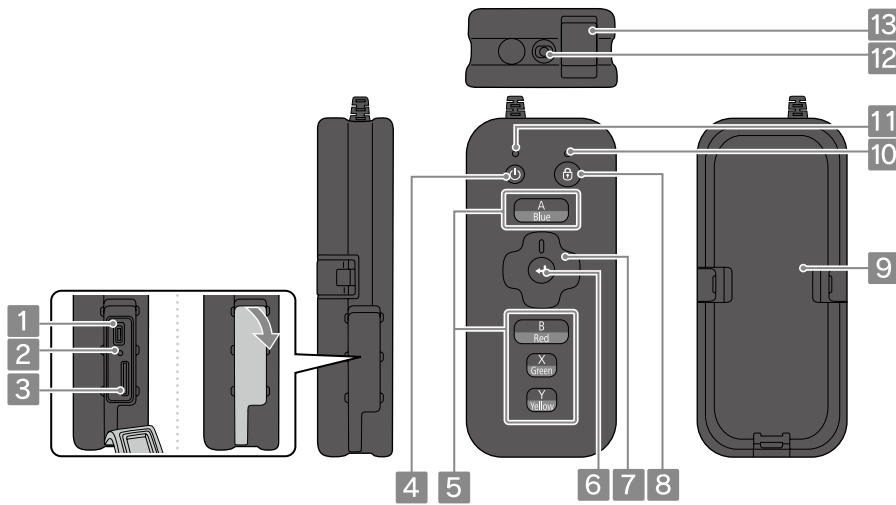

### 1 micro USB port\*

You can connect a commercially available USB cable to connect to a computer.

### 2 Reset button\*

If the product stops working, press this button to force the product to turn off.

### 3 microSD card slot\*

You can insert a commercially available microSD card.

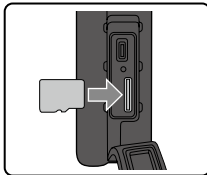

### 4 [⏻] Power button

Turns the product on or off.

➔ "Turning On and Off" p. 10

### 5 ABXY keys

The key functions vary depending on the application being used. The following shows the default settings.

Key	Function
A (Blue) key	Displays the previous screen.
B (Red) key	Displays the Home screen.
X (Green) key	Displays available menus for the current screen.
Y (Yellow) key	Switches the operation performed when you press the cross-key between adjusting the volume, adjusting the brightness, and switching between 2D/3D mode.

### 6 [↵] Enter key

Selects or confirms the item when making settings or operating an application.

### 7 Cross-key

Highlights items and moves the cursor when making settings or operating an application.

### 8 [🔒] Key lock

Disables controller operations (Key lock mode) to prevent accidental operations.

➔ "Disabling controller operations (Key lock)" p. 10

### 9 Battery cover\*

Remove when replacing the battery.

### 10 Key lock indicator

Lit blue when the key lock is on.

### 11 Power indicator

You can check the status of the product according to the color and lit status of the indicator.

Indicator Status	Product Status
Light blue	Operating
Flashing light blue (one second intervals)	Starting up / Shutting down
Flashing light blue (once every three seconds)	Charging
Blue	Sleep mode
Flashing red	Battery running low/Startup error
Flashing red three times	Insufficient battery to start up
Flashing red and blue alternately	Battery replacement mode

### 12 Earphone socket

Connects the supplied mono earphones with mic.

### 13 AC adapter port

Connects the AC adapter to charge the product.

➔ "Charging the Battery" p. 8

\*You cannot use the feature when the controller is in the controller holder.

## Getting Ready

### Charging the Battery

Make sure you charge the product when using it for the first time. Initial charging takes approximately three hours.

#### Caution

Make sure you install two batteries when using the product.

#### 1 Remove the battery cover.

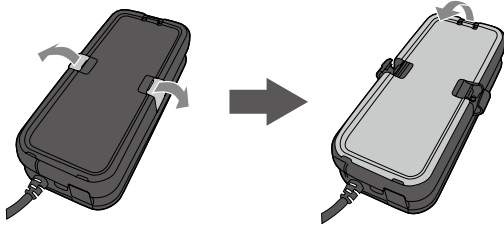

#### 2 Install two batteries.

Align the charging connectors on the battery with those on the product, and then press the battery down until you hear it click into place.



#### 3 Attach the battery cover.

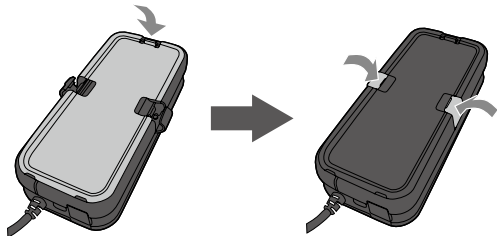

#### 4 Connect the controller, AC adapter, and AC cable.

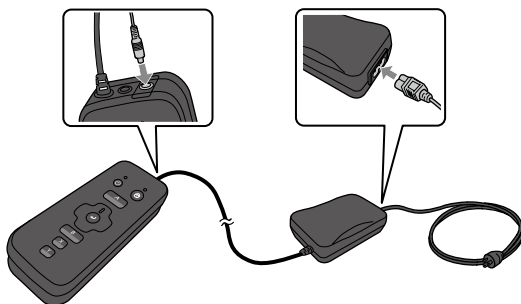

#### 5 Plug in the AC cable.

The power indicator flashes light blue. Charging is complete when the power indicator stops flashing and changes to lit light blue. Disconnect the AC adapter and the AC cable.

#### Note

When charging is complete with two batteries installed, you can use the product for approximately four hours. Battery life may vary depending on the environmental usage conditions and the applications being used.

### Replacing with Optional Batteries

This section explains how to replace a battery with a fully charged battery. You need to purchase optional batteries and a battery charger for replacement.

You can replace the batteries without turning off the product.

#### Caution

Do not remove two batteries at the same time when the product is on. Stored data and settings may be lost.

#### Note

The product guides you through replacing the batteries in Battery replacement mode. Press the [⏻] power button and the [🔒] key lock button at the same time, and then replace the batteries by following the instructions displayed in the headset.

#### 1 Remove the battery cover.

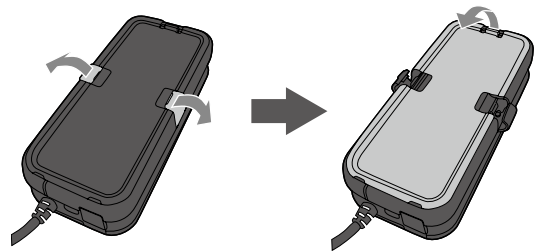

The battery indicator for the battery that is running low flashes red.

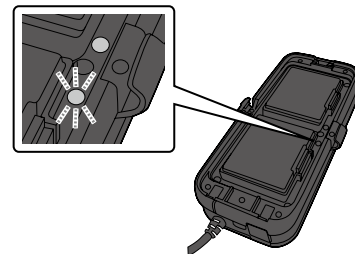

#### Note

When the product is off, the battery indicator does not operate.

#### 2 Remove one battery.

While pressing the battery catch, lift out the battery.





### 3 Install the charged battery.

Align the charging connectors on the battery with those on the product, and then press the battery down until you hear it click into place.



The battery indicator lights green for a while before turning off.

If the battery indicator for the other battery flashes red, repeat the procedure to replace this battery. When both battery indicators turn off, battery replacement is complete.

### 4 Attach the battery cover.

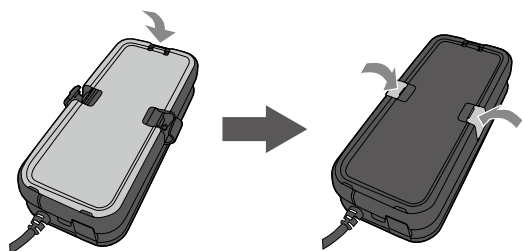

#### Note

If the battery indicator flashes red and green alternately, there is an error with the battery. Turn off the product, wait for a while, and then turn it back on.

## Replacing the Inner Pad

The inner pad B is attached to the headset at the time of purchase. If the headset feels tight, replace this with inner pad A or C. The headset feels loose if you attach a smaller inner pad.

### 1 Grip the center of the inner pad and carefully pull it to remove.

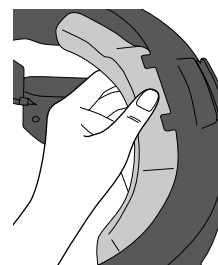

### 2 Align the groove at the bottom of the replacement inner pad with the tabs on the headset.

Press the groove at the top and the tabs on the left and right of the inner pad into the headset to install.

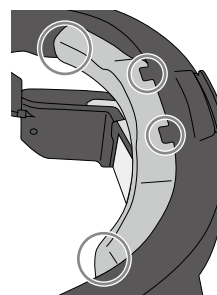

## Installing the Shade/Protective Shield/Lens Holder

Install the shade/protective shield/lens holder using the hexagon wrench and screws supplied with the product.

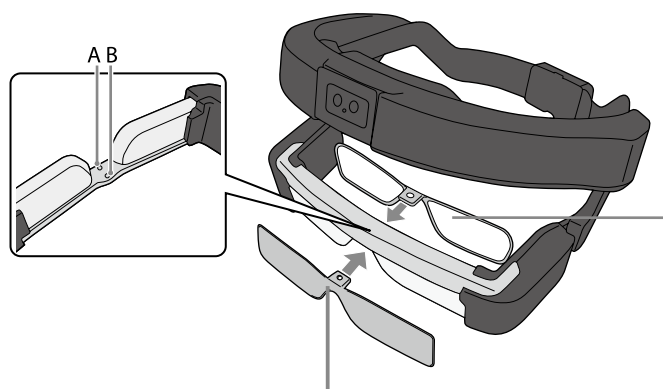

Install the shade or protective shield to the outside of the headset, and secure it in place using screw hole (A). You cannot install the shade and protective shield at the same time.

Before installing the lens holder on the headset, visit your local opticians and have them install lenses in the lens holder. After lenses have been installed, install the holder to the inside of the headset, and secure it in place using screw hole (B). (The customer is responsible for the cost of the lenses. Depending on the opticians, they may not be able to perform this procedure.)

#### Lens holder supported lenses

Lens (W x H)	50 x 24 mm
Nose pads	20 mm
Frame PD	70 mm
Curve	4

#### Note

You may not be able to view images when using special lenses such as colored lenses, mirrored lenses, and polarized lenses.

## Turning On and Off

### Note

Before turning on the product, check that the battery is charged.  
→ "Charging the Battery" p. 8

### Turning on

Press the [⏻] power button until the power indicator is lit light blue.

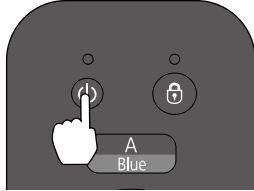

The power indicator flashes light blue when starting up. Startup is complete when the power indicator changes from flashing to lit light blue.

### Turning off the screen while the product is on (Sleep mode)

When you press the [⏻] power button briefly, the power indicator turns blue, and the product enters sleep mode. Press the [⏻] power button briefly again to wake the product from sleep mode.

### Disabling controller operations (Key lock)

When you hold down the [🔒] key lock button, the key lock indicator is lit blue, and the key lock turns on. Press the [🔒] key lock button again to release the key lock.

### Note

- To turn off the product, hold down the [⏻] power button for more than one second, and then select [OK] in the message displayed in the headset.
- If operations freeze, you can force the product to shutdown by using one of the following methods.
  - Hold down the [⏻] power button for more than eight seconds.
  - Use something thin to press the reset button for at least two seconds.

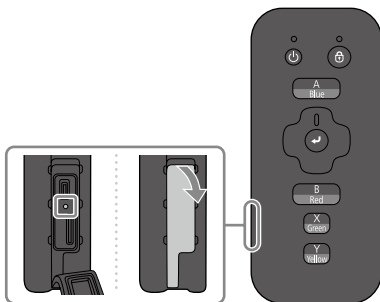

### Caution

Do not force the product to shutdown unless operations freeze. Stored data and settings may be lost.

## Wearing the Product

### Wearing the Controller

This section explains how to wear the controller on your arm using the armband.

### Note

- You can also wear the controller on your waist using a commercially available belt (up to 50 mm thick) instead of the armband.
- Before wearing the controller and headset, put on the supplied mono earphones with mic. Connect it to the earphone socket on the controller, and wear them as shown in the following illustration.



- 1 Thread the armband through the controller holder, and create a loop that will fit roughly to the size of your arm.

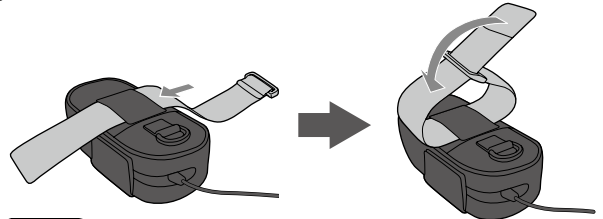

### Note

You can also thread the armband through vertically.

- 2 Unclip the tabs on the sides of the controller holder.

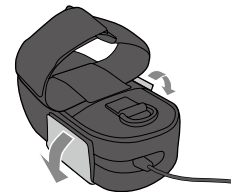

- 3 Wind the cable around the controller holder and secure it in place with the tabs.

Make sure the cable does not catch on anything in the surrounding area.

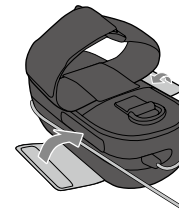

- 4 Place the controller holder on your arm and secure it with the armband.

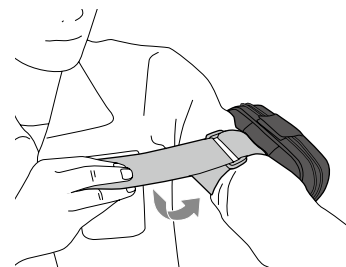

## Wearing the Headset

Wear the headset so that you can view your surroundings when you slide up the lens. When not viewing images, make sure you slide up the lens for your own safety.

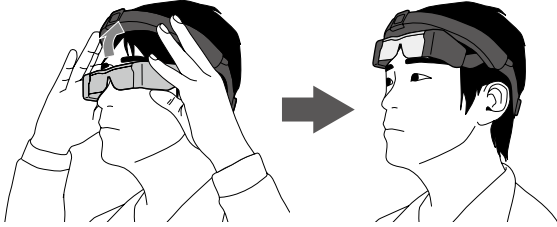

### Note

- You can wear the headset over glasses that are up to 143 mm wide.
- Before you wear the product, check that the power indicator on the product is light blue (turned on).

➔ "Turning On and Off" p. 10

### 1 Move the lens as far away from the head pad as possible.

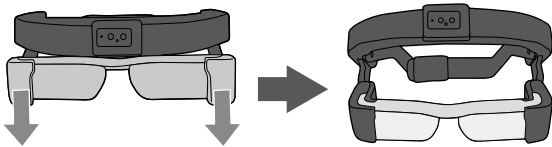

### Note

When wearing the headset over a cap, remove the cap and fit it into the headset.

- The headset may not be able to accommodate caps with a large brim. Also, caps with a large brim may be caught by the camera. We recommend wearing caps with a brim less than 40 mm in width.
- Match the size of the cap with your head in advance.
- Place the head pad on the brim of the cap.
- Adjust the length of the head band according to the size of the cap.

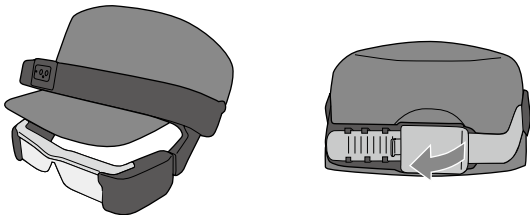

### 2 Run the cable through the cable securer of the headset.

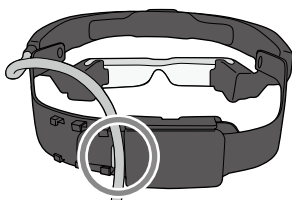

### 3 Tighten the head band and secure the head pad.

Put on the headset from the top.

Hold the head pad to adjust the position so that you can view images on the lens while the head pad is away from the lens.



### Note

When wearing the headset with a cap, make sure there is no gap between the brim of the cap and the head pad.

### 4 If you cannot view a part or any of the image, adjust the lens justifier on either side of the lens.

Make sure the head pad does not slip out of position while adjusting.

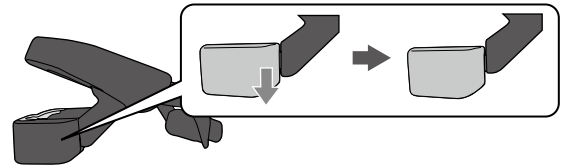

If you still cannot view images even after adjusting the lens justifier, start again from step 1.

### 5 Check that you can slide up the lens to view your surroundings.

If the images impede your visibility when sliding up the lens, or if you cannot slide up the lens, start again from step 1.

### Caution

Do not use too much force when adjusting the position of the headset.

### Note

- If the headset feels tight, replace this with inner pad A or C. The headset feels loose if you attach a smaller inner pad.
- ➔ "Replacing the Inner Pad" p. 9
- When removing the headset, hold the head pad in one hand while loosening the headband to prevent the product from being dropped.



## Viewing Images Using the Headset

When you turn on the product, you can view images through the lens approximately 4 m away from you.

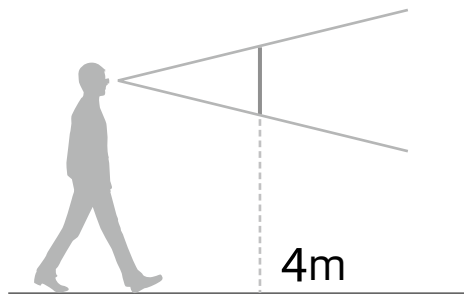

### Note

How an image is perceived varies depending on the individual.

## Maintenance

### Cleaning the Headset

- If you can see marks in the image or if the image is hazy, check that there is no dust, fingerprints, and other dirt on the lens. If the lenses are dirty, wipe them carefully with a soft cloth.

#### Caution

When wiping the lenses, do not use lens cleaning liquids or organic solvents.

- If the camera is dirty, wipe it carefully with a soft cloth.
- If the inner pad is dirty, dampen a cloth in warm water, wring it out thoroughly, and then wipe the inner pad carefully.

### Re-tightening Screws

After using the product for an extended period, the screws securing the lens may become loose.

Re-tighten the screws periodically using the hexagon wrench supplied.

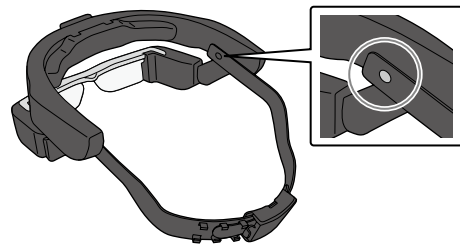

### Storing and Transporting the Headset

- When storing the product, place it in the box it came in, or on the optional hard carry case.
- If you are not going to use the product for a while, remove the batteries before storing the product.
- When placing the headset, make sure it is placed horizontally so that it does not touch against hard objects. If the headset is placed with the lens facing down and the lens touches hard objects, the lens could be damaged.
- When carrying the headset, make sure you grip both sides of the headset firmly so that it is not dropped.

### Cleaning the Charging Connectors

If either of the connectors on the controller or the battery's connectors are dirty or if there are foreign objects stuck to them, you may not be able to charge correctly. Disconnect the AC adapter and the AC cable, and wipe off any dirt with a dry cloth or a cotton swab. We recommend cleaning the charging connectors regularly (once every three months).

#### Caution

- Do not damage the charging connectors with your finger or a hard object.
- Do not expose the charging connectors to water. When cleaning the charging connectors, use a dry cloth or a cotton swab.

## Troubleshooting

If you think a malfunction has occurred, check the following.

### The product does not turn on

---

- Check that the batteries are installed in the controller correctly.
- Check that the batteries are fully charged.
- If the product cannot turn on due to insufficient power, the power indicator flashes red three times.
- Press the [  ] power button until the power indicator is lit light blue. When the power indicator flashes light blue, the product is starting up. Startup is complete when the power indicator changes from flashing to lit light blue.  
➔ "Turning On and Off" p. 10
- When charging cannot be performed or operations are unresponsive, force the product to turn off, and then turn the product back on.
- If the controller gets too hot due to prolonged use or the usage environment, the product may turn off for safety reasons. Also, if the controller gets too hot while charging, the charging could stop temporarily. Wait for the temperature to fall, and then turn the product back on.

### Cannot see images

---

When images are not displayed when the power indicator is light blue, the images may be muted (the product temporarily hides the image).

Tap the right-hand side of the product twice lightly to release the mute function.

If you accidentally activate the mute knock function, you can set it to Off.



### Cannot hear audio

---

To listen to audio from the product, use the mono earphones with mic supplied.

### Cannot use the controller

---

- You cannot perform controller operations when the key lock indicator is lit (Key lock enabled). Press the [  ] key lock button to release key lock.  
➔ "Disabling controller operations (Key lock)" p. 10
- When the power indicator is blue (during Sleep mode), press the [  ] power button briefly.  
➔ "Turning off the screen while the product is on (Sleep mode)" p. 10

### Cannot connect to the network

---

- Check that the wireless LAN (Wi-Fi) environment can be accessed from where you are using the product.
- Check that the product's network settings are correct. Contact your network administrator for more details.

## Specifications

Model Number	BT-2000	
Material	Polysilicon TFT active matrix	
LCD panel size	0.42" wide panel (16:9)	
LCD panel pixel count	Horizontal 960 x vertical 540 dots	
Angle of view	Approximately 23 degrees (diagonally)	
Virtual screen size	64" support (virtual viewing distance 4 m)	
Color reproduction	24 bit color (approximately 16,770,000 colors)	
Platform	Android™ 4.0.4	
Supported movie formats	MP4 (MPEG4+AAC), MPEG2 (H.264+AAC)	
Supported still image formats	JPEG, PNG, BMP, GIF	
Supported audio formats	WAV, MP3, AAC	
Supported 3D	Side-by-side format	
Internal memory	Main memory	1 GB
	User memory	8 GB
External memory	microSD (2 GB maximum) microSDHC (32 GB maximum)	
Connector ports	micro-USB, 4 pin mini jack (earphones with microphone complying with the CTIA standard)*1, microSD card slot	
Operating temperature	0 to 40°C, humidity 20 to 80% (no condensation)	
Charging temperature	5 to 35°C, humidity 20 to 80% (no condensation)	
Storage temperature	-10 to 60°C, humidity 10 to 90% (no condensation)	
Power voltage	Controller	11VDC 1.64A (when AC adapter connected)
	AC adapter	100 to 240 VAC 50 to 60 Hz 0.4 A
Power consumption	When operating at full capacity 4000 mW, when in sleep mode 80 mW, when off 5 mW	
Battery	Type	Lithium-ion batteries 1240 mAh (x2)
	Lithium content	Less than 1.5 g
	Amount of watt hour rating	Less than 20 Wh
Frequency band	IEEE 802.11 b/g/n/a	
Frequency range	2.4 GHz band 1 to 13 ch, 5 GHz band 36 to 140 ch	
Modulation	ODFM, DS-SS	
Potential interference range	10 m	
Battery life	Approx. 4 hours (When operating at full capacity)	
Reliability	Life span	10,000 h (When brightness is set to the default, and used continuously in an environment of 25°C. The life span means the point at which the product enters the wear out failure period. Product performance may then degrade, such as a decline in screen luminance of 50% from the initial stages.)
	Mean-Time Between Failure (MTBF)	180,000 hours (Failure means a random failure during the random failure period.)
Exterior dimensions (W x D x H)	Headset	205 x 136 x 100 mm (without the head band)
	Controller	70 x 157 x 35.3 mm (without protruding section)
Mass	Headset	290g (without cables)
	Controller	265 g (without batteries, 1 battery is approx. 50 g)
Camera	5 million pixels (still image, movie), 0.3 million pixels (depth sensing)	
Earphones with mic	Earphone impedance	16Ω±10%
	Earphone output	Max. voltage 150 mV or less Voltage with broadband characteristics 75 mV or more
	Mic	Capacitor microphone
Sensors	GPS/geomagnetic sensor/IMU (accelerometer/gyroscopic sensor)/illumination sensor	
Bluetooth 3.0	HSP/A2DP/HID/OPP/SPP/AVRCP	
Bluetooth 4.0 LE	PXP/FMP	

\*1 Restrictions in operation may occur when using an adapter plug.

# Intellectual Property Rights

Trademarks



microSDHC Logo is a trademark of SD-3C, LLC.

Wi-Fi® and Wi-Fi Direct™ are the trademarks or registered trademarks of the Wi-Fi Alliance.

Other product names used herein are also for identification purposes only and may be trademarks of their respective owners. Epson disclaims any and all rights in those marks.

OPEN SOURCE SOFTWARE LICENSE

As well as software owned by Epson, this product also uses open source software.

The following provides information on the open source software used in this product.

1. This product includes open source software programs according to the license terms of each program.  
The open source software programs are without warranty; however, any malfunctions (including malfunctions caused by the open source software programs) that occur in this product do not influence the warranty conditions provided for this product.
2. We provide the source code of some open source software programs. If you desire to receive the source code above, please see the "http://www.epson.com" and contact the customer support of your region. We provide the source code until five (5) years after the discontinuation of this product. You shall comply with the license terms of each open source software program.
3. The open source software programs are WITHOUT ANY WARRANTY; without even the implied warranty of MERCHANTABILITY AND FITNESS FOR A PARTICULAR PURPOSE. See the license agreements of each open source software program for more details, which are described in the product.
4. The license terms of each open source software program are described in Home screen > Settings > About device > Legal information > Open source licenses of the product.

## General Notes

Notes Regarding Wireless LAN

Do not use the Wireless LAN function in France unless you are indoors.

If you purchase this product outside of North America and Taiwan, please note that this product emits wireless LAN electromagnetic waves on channels 1 to 13. Therefore, do not use the wireless LAN function in North America and Taiwan where wireless LAN channels are limited to 1 to 11 by the Wireless Telegraphy Act.

Follow local laws and regulations when using in other regions.

Wireless Telegraphy Act Regulations

The following acts are prohibited by the Wireless Telegraphy Act.

- Modifying and disassembling (including the antenna)
- Removing the label of conformance
- Using the 5 GHz bandwidth LAN when outdoors

Restriction of Use

This product is manufactured based on the specifications of the country of sale. When using this product outside the country of sale, contact your nearest support center.

When this product is used for applications requiring high reliability/safety of function and precision, such as transportation devices related to aviation, rail, marine, automotive; disaster prevention devices; various safety devices, you should use this product only after giving consideration to including fail-safes and redundancies into your design to maintain safety and total system reliability.

Because this product was not intended for use in applications requiring extremely high reliability/safety such as aerospace equipment, main communication equipment, nuclear power control equipment, or medical equipment related to direct medical care, please make your own judgment on this product's suitability after a full evaluation.

Notes on Frequency

This product operates in the same frequency bandwidth as industrial devices such as microwave ovens, scientific, and medical devices and mobile object identification (RF-ID) systems (licensed premises radio stations, amateur, and unlicensed specified low-power radio stations (hereafter "other radio stations")) used in factory production lines.

1. Before using this device, make sure there are no "other radio stations" being used in the vicinity.
2. If this device causes RF interference between the device and "other radio stations", promptly move to a different location, stop using the device, and contact your local dealer to ask for advice on preventing interference (for example setting up partitions).
3. In addition, when harmful radio wave interference occurs between the device and "other radio stations", contact your local dealer.

Authentication information

U.S.A.

Contains FCC ID : RYYWYSAAVDXB-E , RYYEYSFCN



Canada

Contains IC : 4389B-WYSAAVDXB-E , 4389B-EYSFCN



Europe

Japan



R 001-A05576  
R 001-A01718



Singapore

Complies with IDA standards DB101624

## General Notes

FCC Compliance Statement	<p>This equipment has been tested and found to comply with the limits for a Class A digital device, pursuant to part 15 of the FCC Rules. These limits are designed to provide reasonable protection against harmful interference when the equipment is operated in a commercial environment. This equipment generates, uses, and can radiate radio frequency energy and, if not installed and used in accordance with the instruction manual, may cause harmful interference to radio communications. Operation of this equipment in a residential area is likely to cause harmful interference in which case users will be required to correct the interference at their own expense.</p> <p><b>WARNING</b></p> <p>The connection of a non-shielded equipment interface cable to this equipment will invalidate the FCC Certification or Declaration of this device and may cause interference levels which exceed the limits established by the FCC for this equipment. It is the responsibility of the user to obtain and use a shielded equipment interface cable with this device. If this equipment has more than one interface connector, do not leave cables connected to unused interfaces. Changes or modifications not expressly approved by the manufacturer could void the user's authority to operate the equipment.</p>
FCC/Industry Canada (IC) Notices	<p><b>FCC Notices</b></p> <p>This device complies with Part 15 of the FCC Rules. Operation is subject to the following two conditions: (1) this device may not cause harmful interference, and (2) this device must accept any interference received, including interference that may cause undesired operation.</p> <p>This equipment complies with FCC radiation exposure limits set forth for an uncontrolled environment. End-users must follow the specific operating instructions for satisfying RF exposure compliance. This transmitter must not be co-located or operating in conjunction with any other antenna or transmitter.</p> <p>Caution:</p> <p>You are cautioned that changes or modifications not expressly approved by the party responsible for compliance could void your authority to operate the equipment.</p> <p><b>Industry Canada (IC) Notices</b></p> <p><u>CAN ICES-3 (A)/NMB-3(A)</u></p> <p>This Class A digital apparatus complies with Canadian ICES-003. Cet appareil numérique de la classe A est conforme à la norme NMB-003 du Canada.</p> <p>This equipment complies with RF radiation exposure limits set forth for an uncontrolled environment. End-users must follow the specific operating instructions for satisfying RF exposure compliance. This transmitter must not be co-located or operating in conjunction with any other antenna or transmitter.</p>
SAR Notices	<p>This device with the WLAN device has been tested to SAR and complies to FCC and IC exposure requirements for portable devices. SAR testing has been done at distance of 0 cm from the body.</p> <p>Cet appareil avec l'appareil W-LAN a été testé aux SAR et est conforme aux exigences des FCC et IC exposition pour les appareils portables. Le test SAR a été fait à distance de 0 cm du corps.</p>
	<p>Indication of the manufacturer and the importer in accordance with requirements of directive 2011/65/EU (RoHS)</p> <p>Manufacturer: SEIKO EPSON CORPORATION Address: 3-5, Owa 3-chome, Suwa-shi, Nagano-ken 392-8502 Japan Telephone: 81-266-52-3131 <a href="http://www.epson.com/">http://www.epson.com/</a></p> <p>Importer: EPSON EUROPE B.V. Address: Atlas Arena, Asia Building, Hoogoorddreef 5, 1101 BA Amsterdam Zuidoost The Netherlands Telephone: 31-20-314-5000 <a href="http://www.epson.com/europe.html">http://www.epson.com/europe.html</a></p>





**EPSON**  
EXCEED YOUR VISION

DECLARATION of CONFORMITY

Manufacturer:	SEIKO EPSON CORPORATION		
Address:	3-5, Owa 3-chome, Suwa-shi Nagano-ken 392-8502 Japan	Telephone:	81-266-52-3131
		Fax:	81-266-52-8409

Representative:	EPSON FRANCE S.A.		
Address:	PARC TECHNOLOGIQUE EUROPARC 60, RUE AUGUSTE PERRET 94043 CRETEIL CEDEX FRANCE	Telephone:	33-1-56715720
		Fax:	33-1-56715726

Declares under our responsibility that the product:

Brand Name: EPSON  
Product Name: See Through Mobile Viewer  
Model: H560A (Moverio BT-200)  
For more details, please refer to the product description  
Options: None

Conforms to the following Directive(s) and Norm(s):

Directive 1999/5/EC:  
EN300 328 V1.7.1(2006-10)  
EN300 489-1 V1.9.2(2011-09)  
EN300 489-17 V2.2.1(2012-09)  
EN55022(2010)ClassB  
EN55024(2010)  
EN61000-3-2(2006)+A1(2009)+A2(2009)  
EN61000-3-3(2008)  
EN60065(2002)+A1(2006)+A11(2008)+A2(2010)+A12(2011)  
EN60950-1(2006)+A11(2009)+A1(2010)+A12(2011)  
1999/519/EC  
EN50566(2013)

Directive 2009/125/EC:  
Commission Regulation(EC)No.1275/2008

Directive 2011/65/EU: EN 50581(2012)

The year in which the CE marking was affixed, is 2014.

March 10, 2014

澤田 敦也

Atsunari Tsuda  
General Manager of HMD Business Management Dept.  
Visual Products Operations Div.  
SEIKO EPSON CORPORATION.

E0658-00

Declared based on "Technical Data File, Mar.10th,2014."

Model : H560A

## Contact List

This address list is current as of December 2013.

A more up-to-date contact address can be obtained from the corresponding website listed here. If you do not find what you need on any of these pages, please visit the main Epson home page at [www.epson.com](http://www.epson.com).

### EUROPE, MIDDLE EAST & AFRICA

**ALBANIA**

ITD Sh.p.k.  
<http://www.itd-al.com>

**AUSTRIA**

Epson Deutschland GmbH  
<http://www.epson.at>

**BELGIUM**

Epson Europe B.V.  
Branch office Belgium  
<http://www.epson.be>

**BOSNIA AND HERZEGOVINA**

NET d.o.o. Computer Engineering  
<http://www.net.com.ba>

**BULGARIA**

Epson Service Center Bulgaria  
<http://www.kolbis.com>

**CROATIA**

MR servis d.o.o.  
<http://www.mrservis.hr>

**CYPRUS**

Mechatronic Ltd.  
<http://www.mechatronic.com.cy>

**CZECH REPUBLIC**

Epson Europe B.V.  
Branch Office Czech Republic  
<http://www.epson.cz>

**DENMARK**

Epson Denmark  
<http://www.epson.dk>

**ESTONIA**

Epson Service Center Estonia  
<http://www.epson.ee>

**FINLAND**

Epson Finland  
<http://www.epson.fi>

**FRANCE & DOM-TOM TERRITORY**

Epson France S.A.  
<http://www.epson.fr>

**GERMANY**

Epson Deutschland GmbH  
<http://www.epson.de>

**GREECE**

Oktabit S.A.  
<http://www.oktabitgr.com>

**HUNGARY**

Epson Europe B.V.  
Branch Office Hungary  
<http://www.epson.hu>

**IRELAND**

Epson (UK) Ltd.  
<http://www.epson.ie>

**ISRAEL**

Epson Israel  
<http://www.epson.co.il>

**ITALY**

Epson Italia s.p.a.  
<http://www.epson.it>

**KAZAKHSTAN**

Epson Kazakhstan Rep. Office  
<http://www.epson.kz>

**LATVIA**

Epson Service Center Latvia  
<http://www.epson.lv>

**LITHUANIA**

Epson Service Center Lithuania  
<http://www.epson.lt>

**LUXEMBURG**

Epson Europe B.V.  
Branch office Belgium  
<http://www.epson.be>

**MACEDONIA**

Digit Computer Engineering  
<http://www.digit.com.mk>

**NETHERLANDS**

Epson Europe B.V.  
Benelux sales office  
<http://www.epson.nl>

**NORWAY**

Epson Norway  
<http://www.epson.no>

**POLAND**

Epson Europe B.V.  
Branch Office Poland  
<http://www.epson.pl>

**PORTUGAL**

Epson Ibérica S.A.U.  
Branch Office Portugal  
<http://www.epson.pt>

**ROMANIA**

Epson Europe B.V.  
Branch Office Romania  
<http://www.epson.ro>

**RUSSIA**

Epson CIS  
<http://www.epson.ru>

**UKRAINE**

Epson Kiev Rep. Office  
<http://www.epson.ua>

**SERBIA**

AVG d.o.o. Beograd  
<http://www.a-v-g.rs>

**SLOVAKIA**

Epson Europe B.V.  
Branch Office Czech Republic  
<http://www.epson.sk>

**SLOVENIA**

Birotehna d.o.o.  
<http://www.birotehna.si>

**SPAIN**

Epson Ibérica, S.A.U.  
<http://www.epson.es>

**SWEDEN**

Epson Sweden  
<http://www.epson.se>

**SWITZERLAND**

Epson Deutschland GmbH Branch  
office Switzerland  
<http://www.epson.ch>

**TURKEY**

Tecpro Bilgi Teknolojileri Tic. ve San.  
Ltd. Sti.  
<http://www.tecpro.com.tr>

**UK**

Epson (UK) Ltd.  
<http://www.epson.co.uk>

**AFRICA**

<http://www.epson.co.za>  
or  
<http://www.epson.fr>

**SOUTH AFRICA**

Epson South Africa  
<http://www.epson.co.za>

**MIDDLE EAST**

Epson (Middle East)  
<http://www.epson.ae>

## NORTH, CENTRAL AMERICA & CARIBBEAN ISLANDS

### CANADA

Epson Canada, Ltd.  
<http://www.epson.ca>

### COSTA RICA

Epson Costa Rica, S.A.  
<http://www.epson.co.cr>

### MEXICO

Epson Mexico, S.A. de C.V.  
<http://www.epson.com.mx>

### ECUADOR

Epson Ecuador  
<http://www.epson.com.ec>

### U. S. A.

Epson America, Inc.  
<http://www.epson.com>

## SOUTH AMERICA

### ARGENTINA

Epson Argentina S.R.L.  
<http://www.epson.com.ar>

### BRAZIL

Epson do Brasil  
<http://www.epson.com.br>

### CHILE

Epson Chile S.A.  
<http://www.epson.cl>

### COLOMBIA

Epson Colombia Ltd.  
<http://www.epson.com.co>

### PERU

Epson Peru S.A.  
<http://www.epson.com.pe>

### VENEZUELA

Epson Venezuela S.A.  
<http://www.epson.com.ve>

## ASIA & OCEANIA

### AUSTRALIA

Epson Australia Pty. Ltd.  
<http://www.epson.com.au>

### CHINA

Epson (China) Co., Ltd.  
<http://www.epson.com.cn>

### HONG KONG

Epson Hong Kong Ltd.  
<http://www.epson.com.hk>

### INDIA

Epson India Pvt., Ltd.  
<http://www.epson.co.in>

### INDONESIA

PT. Epson Indonesia  
<http://www.epson.co.id>

### JAPAN

Seiko Epson Co.  
Toyoshina Plant  
<http://www.epson.jp>

### KOREA

Epson Korea Co., Ltd.  
<http://www.epson.co.kr>

### MALAYSIA

Epson Malaysia Sdn. Bhd.  
<http://www.epson.com.my>

### NEW ZEALAND

Epson New Zealand  
<http://www.epson.co.nz>

### PHILIPPINES

Epson Philippines Co.  
<http://www.epson.com.ph>

### SINGAPORE

Epson Singapore Pte. Ltd.  
<http://www.epson.com.sg>

### TAIWAN

Epson Taiwan  
<http://www.epson.com.tw>

### THAILAND

Epson (Thailand) Co.,Ltd.  
<http://www.epson.co.th>

