



Prüfbericht-Nr.: <i>Test Report No.:</i>	50339907 001	Auftrags-Nr.: <i>Order No.:</i>	238112053	Seite 1 von 63 <i>Page 1 of 63</i>
Kunden-Referenz-Nr.: <i>Client Reference No.:</i>	N/A	Auftragsdatum: <i>Order date:</i>	8-Nov-2019	
Auftraggeber: <i>Client:</i>	TAIYO YUDEN CO., LTD. 43-1, Yawatabara-machi, Takasaki-shi, Gunma, 370-0024, Japan			
Prüfgegenstand: <i>Test item:</i>	Bluetooth low energy/ ANT/ 802.15.4 Module			
Bezeichnung / Typ-Nr.: <i>Identification / Type No.:</i>	EYSNSN			
Auftrags-Inhalt: <i>Order content:</i>	FCC Part 15C / IC RSS-247 Test report			
Prüfgrundlage: <i>Test specification:</i>	FCC 47CFR Part 15: Subpart C Section 15.247(DTS) ISED RSS-247 (02-2017)			
Wareneingangsdatum: <i>Date of receipt:</i>	12-Dec-2019			
Prüfmuster-Nr.: <i>Test sample No.:</i>	A001041701-006			
Prüfzeitraum: <i>Testing period:</i>	3-Jan-2020~03-Feb-2020			
Ort der Prüfung: <i>Place of testing:</i>	EMC/RF Laboratory Taipei			
Prüflaboratorium: <i>Testing laboratory:</i>	TUV Rheinland Taiwan Ltd.			
Prüfergebnis*: <i>Test result*:</i>	Pass			
Report date / tested by:		kontrolliert von / reviewed by:		
04-Feb-2020 Mars Y.J. Lin/ Project Engineer		04-Feb-2020 Ryan W. T. Chen / Project Manager		
Datum <i>Date</i>	Name / Stellung <i>Name / Position</i>	Unterschrift <i>Signature</i>	Datum <i>Date</i>	Name / Stellung <i>Name / Position</i>
				
Sonstiges / Other:				
Zustand des Prüfgegenstandes bei Anlieferung: <i>Condition of the test item at delivery:</i>		Prüfmuster vollständig und unbeschädigt <i>Test item complete and undamaged</i>		
* Legende: 1 = sehr gut 2 = gut 3 = befriedigend 4 = ausreichend 5 = mangelhaft P(ass) = entspricht o.g. Prüfgrundlage(n) F(ail) = entspricht nicht o.g. Prüfgrundlage(n) N/A = nicht anwendbar N/T = nicht getestet Legend: 1 = very good 2 = good 3 = satisfactory 4 = sufficient 5 = poor P(ass) = passed a.m. test specification(s) F(ail) = failed a.m. test specification(s) N/A = not applicable N/T = not tested				
Dieser Prüfbericht bezieht sich nur auf das o.g. Prüfmuster und darf ohne Genehmigung der Prüfstelle nicht auszugsweise vervielfältigt werden. Dieser Bericht berechtigt nicht zur Verwendung eines Prüfzeichens. <i>This test report only relates to the a. m. test sample. Without permission of the test center this test report is not permitted to be duplicated in extracts. This test report does not entitle to carry any test mark.</i>				

v04

TEST SUMMARY

5.1.1 ANTENNA REQUIREMENT

RESULT: *Passed*

5.1.2 MAXIMUM CONDUCTED PEAK OUTPUT POWER

RESULT: *Passed*

5.1.3 6dB BANDWIDTH AND 99% BANDWIDTH

RESULT: *Passed*

5.1.4 POWER DENSITY

RESULT: *Passed*

5.1.5 CONDUCTED SPURIOUS EMISSIONS AND FREQUENCY BAND EDGE MEASURED IN 100KHZ BANDWIDTH

RESULT: *Passed*

5.1.6 SPURIOUS EMISSION

RESULT: *Passed*

5.2.1 MAINS CONDUCTED EMISSIONS

RESULT: *Passed*

6.1.1 ELECTROMAGNETIC FIELDS

RESULT: *Passed*

Contents

1.	GENERAL REMARKS	5
1.1	COMPLEMENTARY MATERIALS.....	5
1.2	DECISION RULE OF CONFORMITY.....	5
2.	TEST SITES	6
2.1	TEST FACILITY.....	6
2.2	LIST OF TEST AND MEASUREMENT INSTRUMENTS.....	7
2.3	TRACEABILITY	8
2.4	CALIBRATION	8
2.5	MEASUREMENT UNCERTAINTY	8
3.	GENERAL PRODUCT INFORMATION.....	9
3.1	PRODUCT FUNCTION AND INTENDED USE	9
3.2	SYSTEM DETAILS AND RATINGS.....	9
3.3	INDEPENDENT OPERATION MODES.....	11
3.4	NOISE GENERATING AND NOISE SUPPRESSING PARTS	11
3.5	SUBMITTED DOCUMENTS.....	11
4.	TEST SET-UP AND OPERATION MODES.....	12
4.1	PRINCIPLE OF CONFIGURATION SELECTION	12
4.2	TEST OPERATION AND TEST SOFTWARE.....	12
4.3	SPECIAL ACCESSORIES AND AUXILIARY EQUIPMENT	13
4.4	COUNTERMEASURES TO ACHIEVE EMC COMPLIANCE.....	13
4.5	TEST SETUP DIAGRAM	13
5.	TEST RESULTS	15
5.1	TRANSMITTER REQUIREMENT & TEST SUITES.....	15
5.1.1	<i>Antenna Requirement</i>	<i>15</i>
5.1.2	<i>Maximum conducted Peak output power.....</i>	<i>16</i>
5.1.3	<i>6dB Bandwidth and 99% Bandwidth.....</i>	<i>19</i>
5.1.4	<i>Power Density</i>	<i>31</i>
5.1.5	<i>Conducted spurious emissions and Frequency Band Edge measured in 100kHz Bandwidth.....</i>	<i>41</i>
5.1.6	<i>Spurious Emission</i>	<i>55</i>
5.2	MAINS EMISSIONS.....	56
5.2.1	<i>Mains Conducted Emissions.....</i>	<i>56</i>
6.	SAFETY HUMAN EXPOSURE	57

6.1	RADIO FREQUENCY EXPOSURE COMPLIANCE	57
6.1.1	<i>Electromagnetic Fields.....</i>	<i>57</i>
7.	PHOTOGRAPHS OF THE TEST SET-UP.....	58
8.	LIST OF TABLES	63
9.	LIST OF PHOTOGRAPHS.....	63

1. General Remarks

1.1 Complementary Materials

The following attachments are integral parts of this test report:

Appendix P: Photo Documentation internal view
(File Name: 50339907 001 APPENDIXP)

Appendix D: Test Result of Radiated Emissions
(File Name: 50339907 001 APPENDIXD)

Test Specifications

The following standards were applied.

Table 1: Applied Standard and Test Levels

Radio
FCC 47CFR Part 15: Subpart C Section 15.247
FCC 47CFR Part 2: Subpart J Section 2.1091
ISED RSS-247 Issue 2, Feb 2017
ISED RSS-102 Issue 5, March 2015
ISED RSS-Gen, Issue 5, March 2019
ANSI C63.10:2013
KDB558074 D01 DTS Meas Guidance v05r02
KDB447498 D01 General RF Exposure Guidance v06

1.2 Decision Rule of conformity

The decision rule of conformity of this test report is following the requirements of the requested standard in the quotation, and agreed among testing laboratory and manufacturer (applicant) to exclude the consideration of Measurement Uncertainty, unless it is required by the specific standard.

2. Test Sites

TUV Rheinland Taiwan Ltd.

11F. No.758, Sec. 4, Bade Rd., Songshan Dist.
Taipei City 105
Taiwan (R.O.C.)

2.1 Test Facility

TUV Rheinland Taiwan Ltd.

Radiated/Conducted test at below facility:
No. 458-18, Sec 2, Fenliao., Linkou Dist.
New Taipei City 244
Taiwan (R.O.C.)
FCC Registration No.: 226631
IC Canada Registration No.: 25563

Mains Conduction tested at below facility:
11F. No.758, Sec. 4, Bade Rd., Songshan Dist.
Taipei City 105
Taiwan (R.O.C.)

FCC RegistrationNo.: 180491
IC Canada Registration No.: 9465A

TAF Accredited NCC Test Lab. No.:3567
TAF ISO17025 Certification effective period: 6th-May-2019 to 05th-May-2022



Testing Laboratory
3567

2.2 List of Test and Measurement Instruments

Table 2: List of Test and Measurement Equipment

Equipment	Manufacturer	Model No.	Serial No.	Cal. Date	Cal. Due Date
EMI Test Receiver	R&S	ESR7	102108	2019/4/17	2020/4/16
Spectrum Analyzer	R&S	FSV40	101508	2019/2/5	2020/2/5
Pre-Amplifier	Agilent	8447D	2944A10772	2019/02/22	2020/2/21
Pre-Amplifier	EMCI	EMC051845SE	980633	2019/2/25	2020/2/24
Pre-Amplifier	EMCI	EMC184045SE	980657	2019/2/23	2020/2/22
Bilog Antenna	SCHWARZBECK	VULB-9168	00951	2019/1/14	2020/2/13
Horn Antenna	ETS-Lindgren	3117	00218930	2019/12/6	2020/12/5
Horn Antenna	SCHWARZBECK	BBHA 9170	00887	2019/4/12	2020/4/11
Loop Antenna	EMCI	LPA600	287	1/9/2020	2021/1/8
Test Software	Audix	e3	Ver. 9	N/A	N/A
Test Cable	HUBER+SUHNE R	SUCOFLEX 104EA_9k~18G	800056/4EA	2019/4/18	2020/4/17
Test Cable	HUBER+SUHNE R	SUCOFLEX 104_9k~18G	804680/4	2019/4/18	2020/4/17
Test Cable	HUBER+SUHNE R	SUCOFLEX 104_9k~18G	MY37202/4	2019/4/18	2020/4/17
Test Cable	HUBER+SUHNE R	SUCOFLEX 102EA_1G~40 G	800898/2EA	2019/4/18	2020/4/17
Test Cable	HUBER+SUHNE R	SUCOFLEX 102EA_1G~40 G	800901/2EA	2019/4/18	2020/4/17
Test Cable	HUBER+SUHNE R	SUCOFLEX 102EA_1G~40 G	801027/2EA	2019/4/18	2020/4/17
Spectrum Analyzer	R&S	FSV40	101513	2019/2/8	2020/2/8
Power Meter	Anritsu	ML2495A	1901008	2019/4/29	2020/4/28
Power Sensor	Anritsu	MA2411B	1725269	2019/4/29	2020/4/28
EMI Test Receiver	Rohde & Schwarz	ESCI 7	100797	2019/01/16	2020/02/16
Two-Line V- Network (for EUT)	Rohde & Schwarz	ENV216	101243	2019/06/23	2020/06/23
Two-Line V- Network	Rohde & Schwarz	ENV216	101262	2019/07/16	2020/07/16
Impedance Stabilization Network	TESEQ	ISN T800	51949	2019/02/20	2020/02/20
Pulse Limiter	Rohde & Schwarz	ESH3-Z2	0357.8810.54- 102102-HN	2019/07/25	2020/07/25
Test Software	Audix	e3	Ver. 9	N/A	N/A

2.3 Traceability

All measurement equipment calibrations are traceable to NML(Taiwan)/NIST(USA) or where calibration is performed outside Taiwan, to equivalent nationally recognized standards organizations.

2.4 Calibration

Equipment requiring calibration is calibrated periodically in a suitably accredited Calibration Lab. Additionally all equipment is verified for proper performance on a regular schedule using in house standards or comparisons.

2.5 Measurement Uncertainty

The estimated combined standard uncertainty for radiated emissions and conducted emissions measurements .

Table 3: Emission Measurement Uncertainty

Parameter	Uncertainty
Radio Frequency	$\pm 1 \times 10^{-7}$
RF power, conducted	± 1.5 dB
RF power density, conducted	± 3 dB
spurious emissions, conducted	± 3 dB
all emissions, radiated	± 6 dB
Temperature	± 1 °C
Humidity	± 5 %

3. General Product Information

3.1 Product Function and Intended Use

The EUT is a Bluetooth low energy/ ANT/ 802.15.4 Module. It contains a 2.4GHz compatible module enabling the user to communicate data through a Wireless interface.

For details refer to the User Guide, Data Sheet and Circuit Diagram.

3.2 System Details and Ratings

Table 4: Basic Information of EUT

Item	EUT information
Kind of Equipment/Test Item	Bluetooth low energy/ ANT/ 802.15.4 Module
Type Designation	EYSNSN
FCC ID	RYYEYSNSN
IC	4389B-EYSNSN
HVIN	EYSNSN

Table 5: Technical Specification of EUT

Bluetooth Low Energy(1 Mbps, 2Mbps), BLE ; Long range(500kbps, 125kbps)	
Technical Specification	Value
Operating Frequencies	2402~2480MHz
Channel number	40
Operation Voltage	3.3Vdc
Modulation	GFSK
Antenna gain	-3.7dBi

Nordic Original (1Mbps)	
Technical Specification	Value
Operating Frequencies	2402~2480MHz
Channel number	15
Operation Voltage	3.3Vdc
Modulation	GFSK
Antenna gain	-3.7dBi

Nordic Original (2Mbps)	
Technical Specification	Value
Operating Frequencies	2402~2480MHz
Channel number	15
Operation Voltage	3.3Vdc
Modulation	GFSK
Antenna gain	-3.7dBi

IEEE802.15.4	
Technical Specification	Value
Operating Frequencies	2405~2480MHz
Channel number	16
Operation Voltage	3.3Vdc
Modulation	O-QPSK
Antenna gain	-3.7dBi

3.3 Independent Operation Modes

Basic operation modes are:

- A. Transmitting
 - 1. Low channel
 - 2. Middle channel
 - 3. High channel
- B. Receiving
- C. Standby
- D. Off

3.4 Noise Generating and Noise Suppressing Parts

Refer to the Circuit Diagram.

3.5 Submitted Documents

- Circuit Diagram
- Block Diagram
- Rating Label
- Technical Description

4. Test Set-up and Operation Modes

4.1 Principle of Configuration Selection

The equipment under test (EUT) was configured to measure its maximum power level. The test modes were adapted accordingly in reference to the instructions for use.

4.2 Test Operation and Test Software

Setup for testing: The module is mounted on an Evaluation Board provided by the manufacturer. The EVB is provided with an USB-UART interface which makes it possible to control the module through the test software installed on a notebook computer.

This software was running on the laptop computer connected to the EUT. It was used to enable the operation modes listed in section 3.3 as appropriate.

Software: Radio_test_tool_20191008.xls
Power setting is 4.

The samples were used as follows:
Conducted sample: A001041701-006

Full test was applied on all test modes, but only worst case was shown

BLE mode:

Channel Low (2402MHz), Channel Mid (2440MHz) and Channel High (2480MHz) were chosen for full testing. The worst condition was determined based on the test result of Maximum peak output power.

Ir mode:

Channel Low (2402MHz), Channel Mid (2440MHz) and Channel High (2480MHz) were chosen for full testing.

Nordic Original 1M & 2M mode:

Channel Low (2402MHz), Channel Mid (2441MHz) and Channel High (2480MHz) were chosen for full testing.

IEEE802.15.4 mode:

Channel Low (2405MHz), Channel Mid (2440MHz) and Channel High (2480MHz) were chosen for full testing.

4.3 Special Accessories and Auxiliary Equipment

The product has been tested together with the following additional accessories:

Description	Manufacturer	Model No.
Notebook (Setup)	Panasonic	CF-T2

4.4 Countermeasures to achieve EMC Compliance

The test sample which has been tested contained the noise suppression parts as described in the Constructional Data Form or the Technical Construction File. No additional measures were employed to achieve compliance.

4.5 Test Setup Diagram

Diagram of Measurement Configuration for Radiation Test

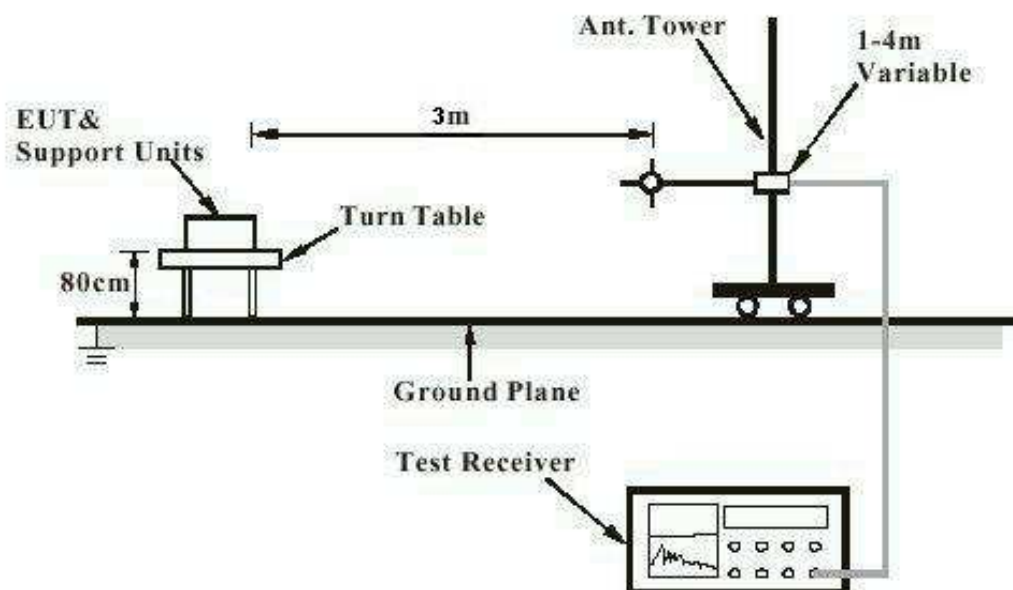

Note: Measurements above 1 GHz are done with a table height of 1.5m

Diagram of Measurement Equipment Configuration for Mains Conduction Measurement (if applicable)

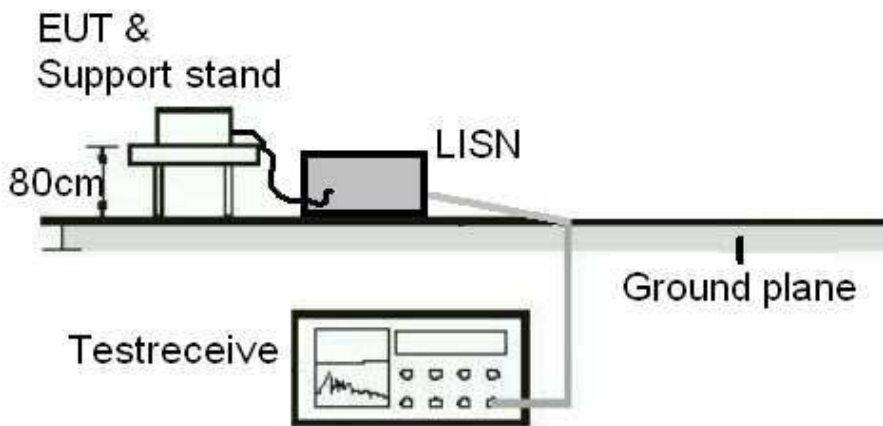
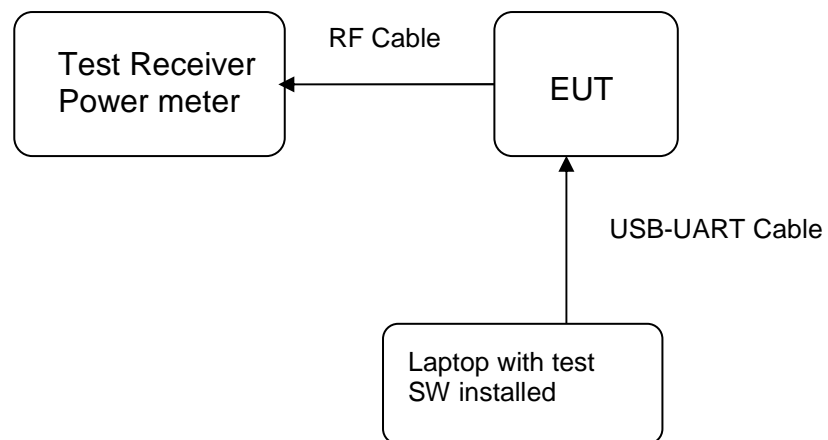

Diagram of Measurement Equipment Configuration for Conducted Transmitter Measurement



Note: The output power is measured by power meter according to 8.3.1.3 KDB558074 D01 Meas Guidance v05r02 8.3.1.3.

5. Test Results

5.1 Transmitter Requirement & Test Suites

5.1.1 Antenna Requirement

RESULT: **Passed**

Test standard : FCC Part 15.247(b)(4), Part 15.203 and ISCED
RSS-Gen 6.8

Requirement : use of approved antennas only with directional gains that
do not exceed 6 dBi

According to the manufacturer declaration, the EUT has an antenna with Max directional gain of -3.7dBi. The antenna is a printed PCB trace with no possibility of replacement with a non-approved antenna by the end-user. Therefore, the EUT is considered to comply with this provision.

Refer to EUT photo for details.

5.1.2 Maximum conducted Peak output power

RESULT:
Passed

Test standard : FCC Part 15.247(b)(3), ISED RSS-247 5.4(b)
 Basic standard : ANSI C63.10:2013, KDB558074(8.3.1.3)
 Limit : 1 Watt
 Kind of test site : Shielded room

Test setup

Test Channel : Low/ Middle/ High
 Operation Mode : A

 Ambient temperature : 20-24 °C
 Relative humidity : 50-65 %
 Atmospheric pressure : 100-103 kPa

Table 6: Test result of Maximum conducted Peak output power, LE 1M

Channel	Channel Frequency (MHz)	Output Power		Average Output Power	Limit
		(dBm)	(W)	(W)	(W)
Low Channel	2402	4.25	0.002661	0.002636	1
Middle Channel	2440	4.24	0.002655	0.002630	1
High Channel	2480	4.24	0.002655	0.002630	1

Table 7: Test result of Maximum conducted Peak output power, LE 2M

Channel	Channel Frequency (MHz)	Output Power		Average Output Power	Limit
		(dBm)	(W)	(W)	(W)
Low Channel	2402	4.21	0.002636	0.002612	1
Middle Channel	2440	4.20	0.002630	0.002606	1
High Channel	2480	4.21	0.002636	0.002612	1

Table 8: Test result of Maximum conducted Peak output power, BLE Long range (125KMbps)

Channel	Channel Frequency	Output Power		Average Output Power	Limit
		(dBm)	(W)		
	(MHz)			(W)	(W)
Low Channel	2402	4.22	0.002642	0.002618	1
Middle Channel	2440	4.19	0.002624	0.002606	1
High Channel	2480	4.19	0.002624	0.002606	1

Table 9: Test result of Maximum conducted Peak output power, BLE Long range (500KMbps)

Channel	Channel Frequency	Output Power		Average Output Power	Limit
		(dBm)	(W)		
	(MHz)			(W)	(W)
Low Channel	2402	4.19	0.002624	0.002600	1
Middle Channel	2440	4.19	0.002624	0.002600	1
High Channel	2480	4.18	0.002618	0.002600	1

Table 10: Test result of Maximum conducted Peak output power, ANT 1M

Channel	Channel Frequency (MHz)	Output Power		Average Output Power	Limit
		(dBm)	(W)		
				(W)	(W)
Low Channel	2402	4.25	0.002661	0.002636	1
Middle Channel	2441	4.22	0.002642	0.002618	1
High Channel	2480	4.22	0.002642	0.002624	1

Table 11: Test result of Maximum conducted Peak output power, Nordic Original 2M

Channel	Channel Frequency (MHz)	Output Power		Average Output Power	Limit
		(dBm)	(W)		
				(W)	(W)
Low Channel	2402	4.23	0.002649	0.002624	1
Middle Channel	2441	4.21	0.002636	0.002612	1
High Channel	2480	4.22	0.002642	0.002618	1

Table 12: Test result of Maximum conducted Peak output power, IEEE 802.15.4

Channel	Channel Frequency (MHz)	Output Power		Average Output Power	Limit
		(dBm)	(W)	(W)	(W)
Low Channel	2405	4.23	0.002649	0.002624	1
Middle Channel	2440	4.22	0.002642	0.002618	1
High Channel	2480	4.23	0.002649	0.002618	1

5.1.3 6dB Bandwidth and 99% Bandwidth

RESULT:
Passed

Test standard : FCC Part 15.247(a)(2), ISED RSS-247 5.2(a)
 ISED RSS-Gen (Issue 5) 6.7
 Basic standard : ANSI C63.10:2013, KDB558074
 Kind of test site : Shielded room

Test setup

Test Channel : Low/ Middle/ High
 Operation Mode : A

 Ambient temperature : 20-24°C
 Relative humidity : 50-65%
 Atmospheric pressure : 100-103 kPa

Table 13: Test result of 6dB Bandwidth, LE 1M

Channel	Channel Frequency (MHz)	6dB Bandwidth (kHz)	Limit (kHz)	Result
Low Channel	2402	716.3	>500	Pass
Mid Channel	2440	710.3	>500	Pass
High Channel	2480	707.3	>500	Pass

Table 14: Test result of 6dB Bandwidth, LE 2M

Channel	Channel Frequency (MHz)	6dB Bandwidth (MHz)	Limit (kHz)	Result
Low Channel	2402	1.1489	>500	Pass
Mid Channel	2440	1.1489	>500	Pass
High Channel	2480	1.1489	>500	Pass

Table 15: Test result of 6dB Bandwidth, ANT 1M

Channel	Channel Frequency (MHz)	6dB Bandwidth (kHz)	Limit (kHz)	Result
Low Channel	2402	500.50	>500	Pass
Mid Channel	2441	502.50	>500	Pass
High Channel	2480	500.50	>500	Pass

Table 16: Test result of 6dB Bandwidth, Nordic Original 2M

Channel	Channel Frequency (MHz)	6dB Bandwidth (kHz)	Limit (kHz)	Result
Low Channel	2402	844.2	>500	Pass
Mid Channel	2441	843.2	>500	Pass
High Channel	2480	844.2	>500	Pass

Table 17: Test result of 6dB Bandwidth, IEEE 802.15.4

Channel	Channel Frequency (MHz)	6dB Bandwidth (MHz)	Limit (kHz)	Result
Low Channel	2405	1.1889	>500	Pass
Mid Channel	2440	1.2138	>500	Pass
High Channel	2480	1.2138	>500	Pass

Table 18: Test result of 99% Bandwidth, LE 1M

Channel	Channel Frequency (MHz)	99% Bandwidth (MHz)
Mid Channel	2440	1.0400

Table 19: Test result of 99% Bandwidth, LE 2M

Channel	Channel Frequency (MHz)	99% Bandwidth (MHz)
Mid Channel	2440	2.0280

Table 20: Test result of 99% Bandwidth, ANT 1M

Channel	Channel Frequency (MHz)	99% Bandwidth (kHz)
Mid Channel	2441	896.1039

Table 21: Test result of 99% Bandwidth, Nordic Original 2M

Channel	Channel Frequency (MHz)	99% Bandwidth (MHz)
Mid Channel	2441	1.7283

Table 22: Test result of 99% Bandwidth, IEEE 802.15.4

Channel	Channel Frequency (MHz)	99% Bandwidth (MHz)
Mid Channel	2440	2.2378

Test Plot of 6dB Bandwidth, LE 1M

Low Channel

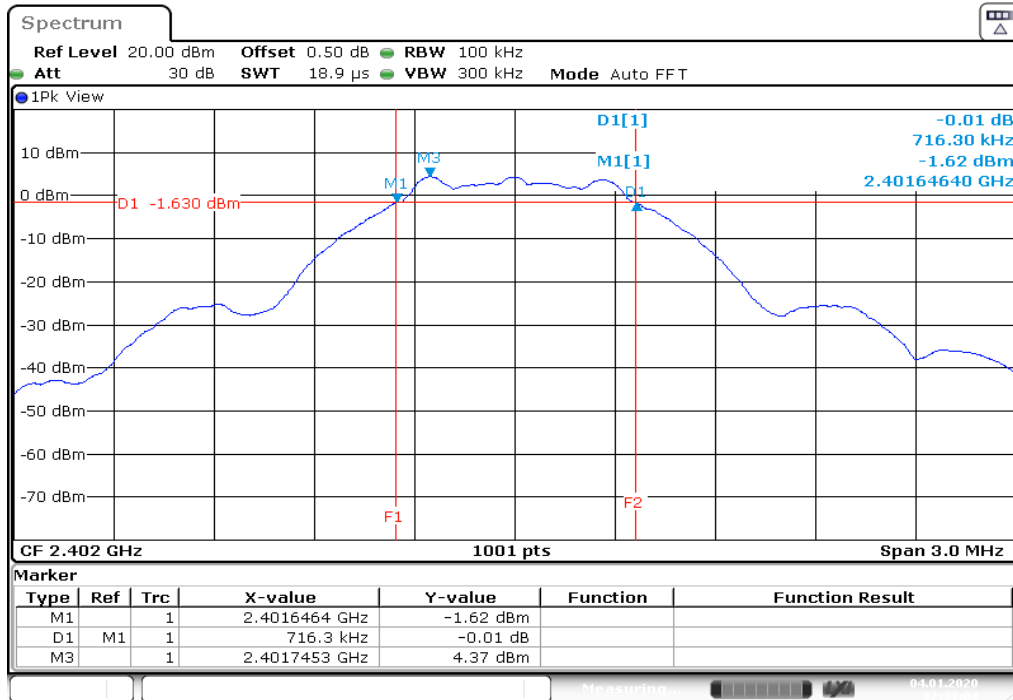

Date: 4.JAN.2020 07:33:05

Middle Channel

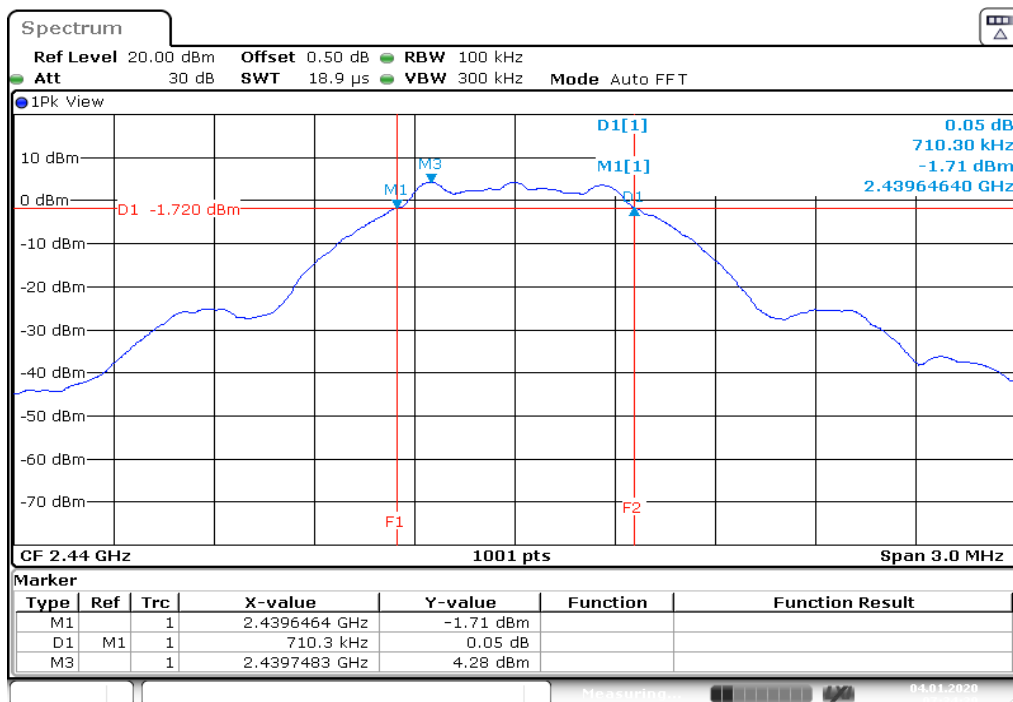

Date: 4.JAN.2020 07:34:39

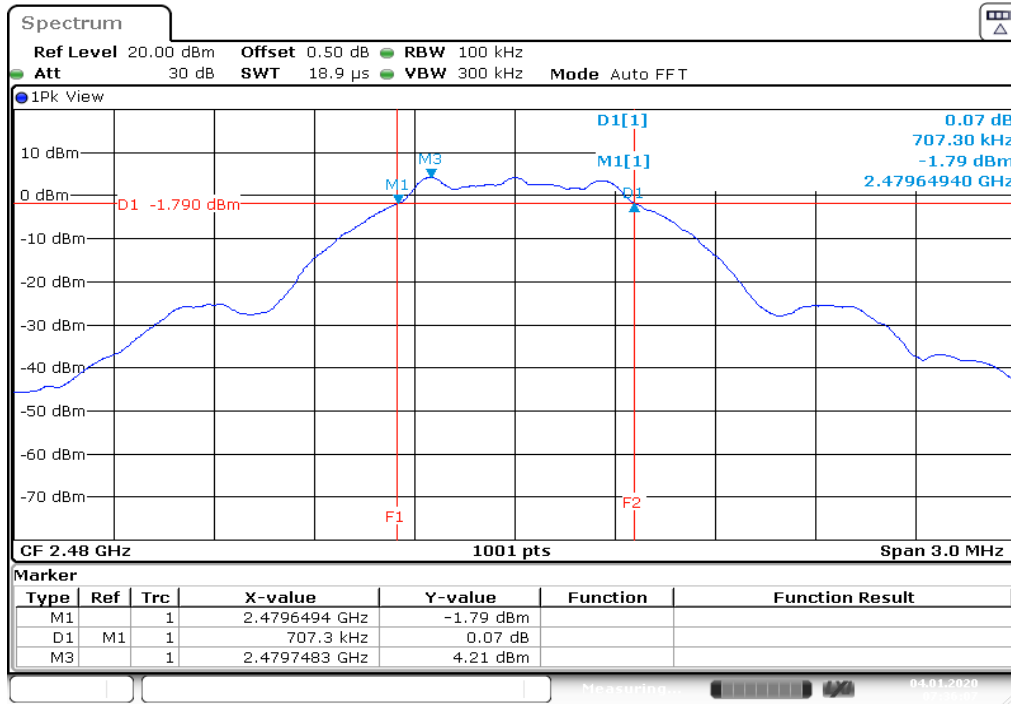
High Channel

Date: 4.JAN.2020 07:36:07

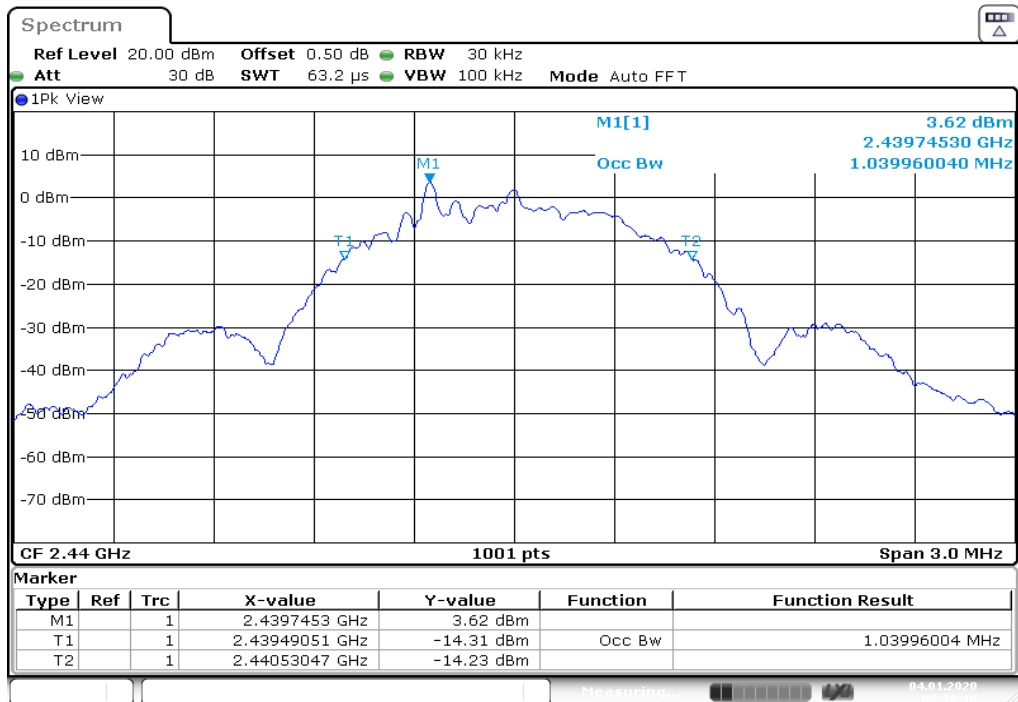
Test Plot of 99% Bandwidth, LE 1M
Middle Channel

Date: 4.JAN.2020 07:38:10

Test Plot of 6dB Bandwidth, LE 2M

Low Channel

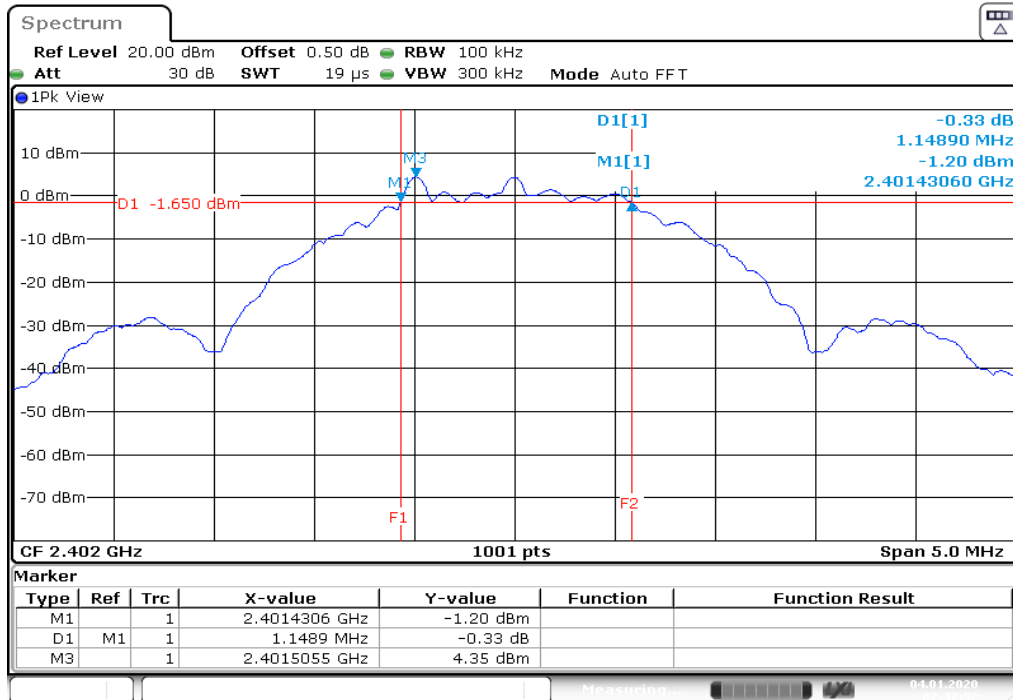

Middle Channel

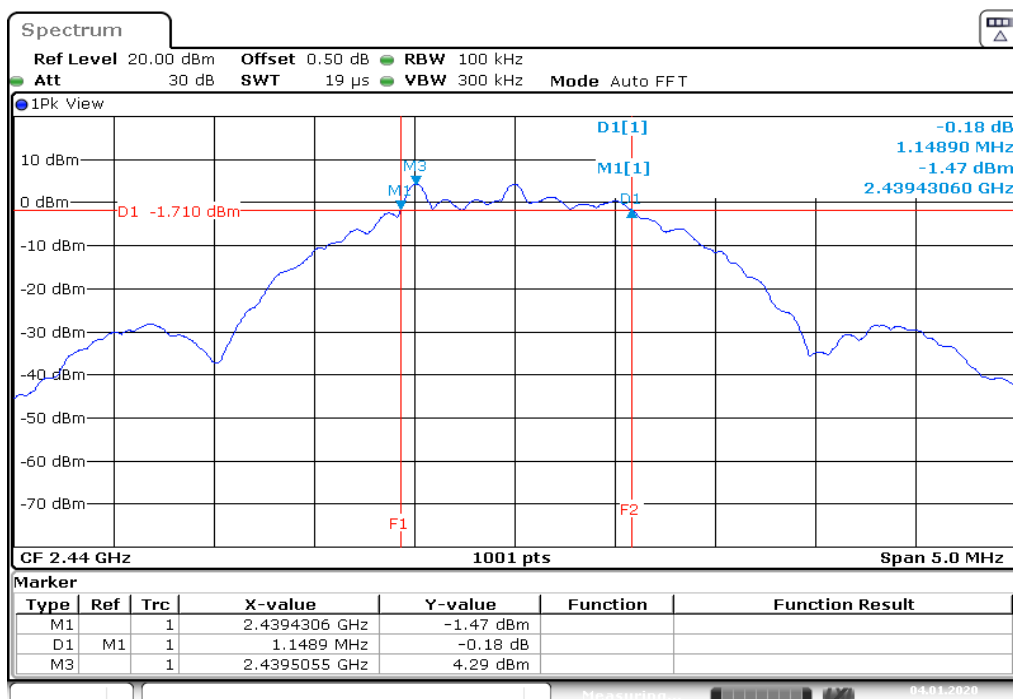

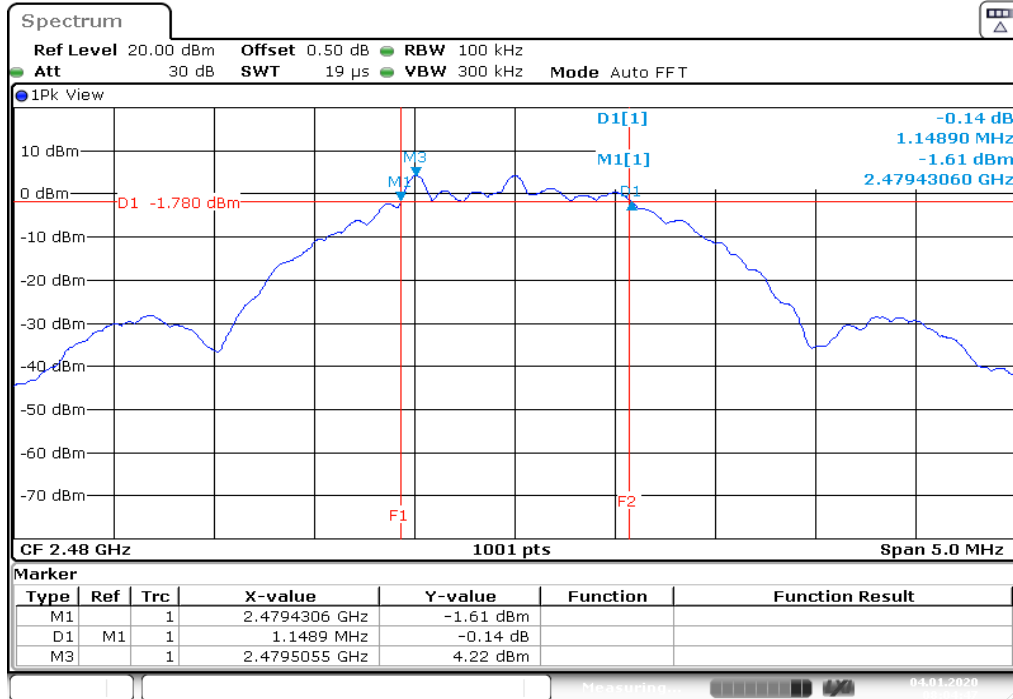
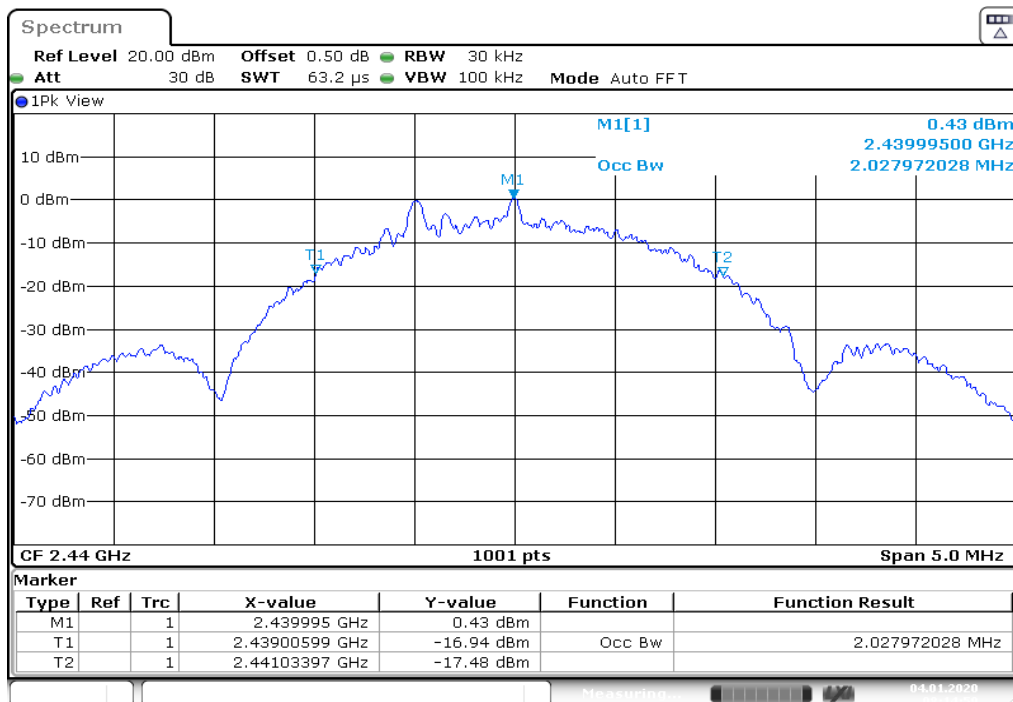
High Channel

Test Plot of 99% Bandwidth, LE 2M
Middle Channel

Test Plot of 6dB Bandwidth, ANT 1M

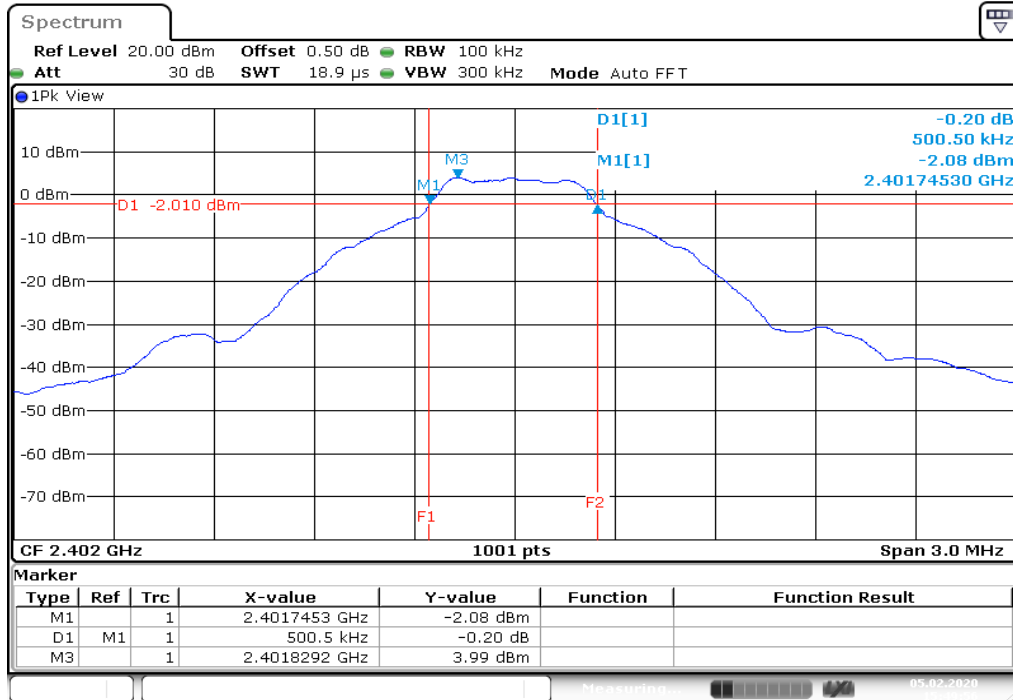
Low Channel



Date: 5.FEB.2020 15:49:56

Middle Channel

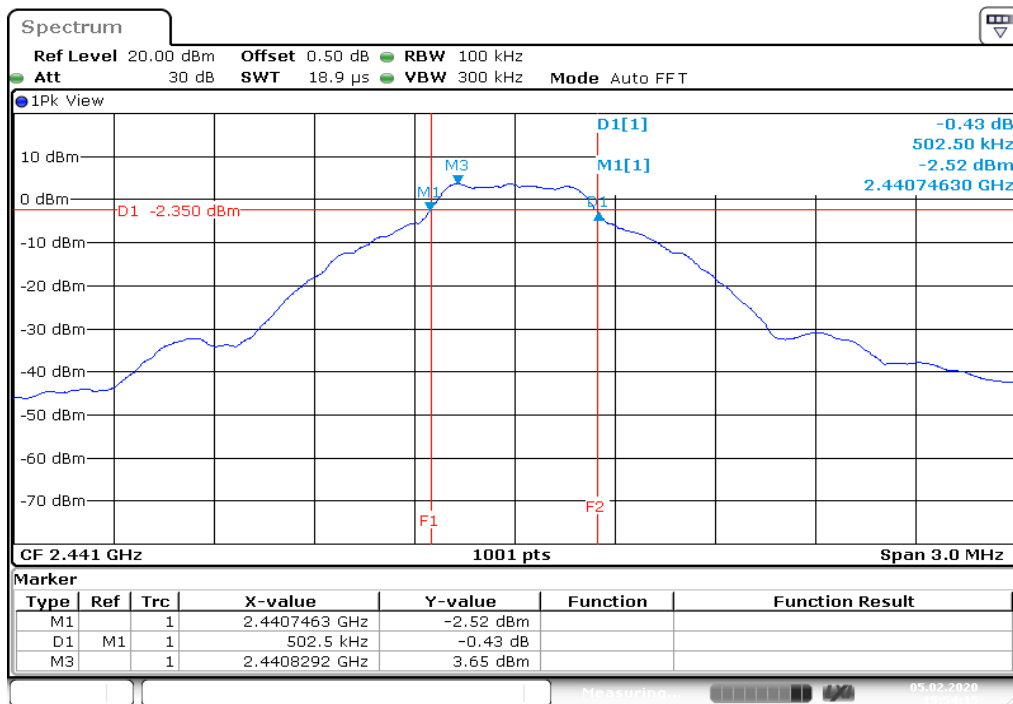

Date: 5.FEB.2020 15:54:15

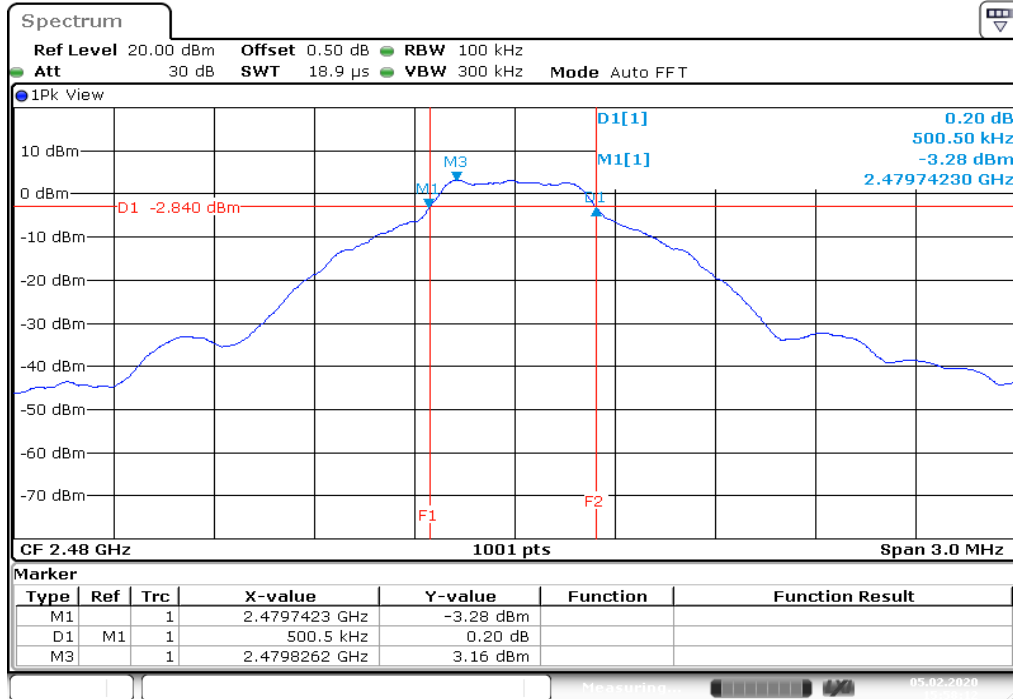
High Channel

Date: 5.FEB.2020 15:58:12

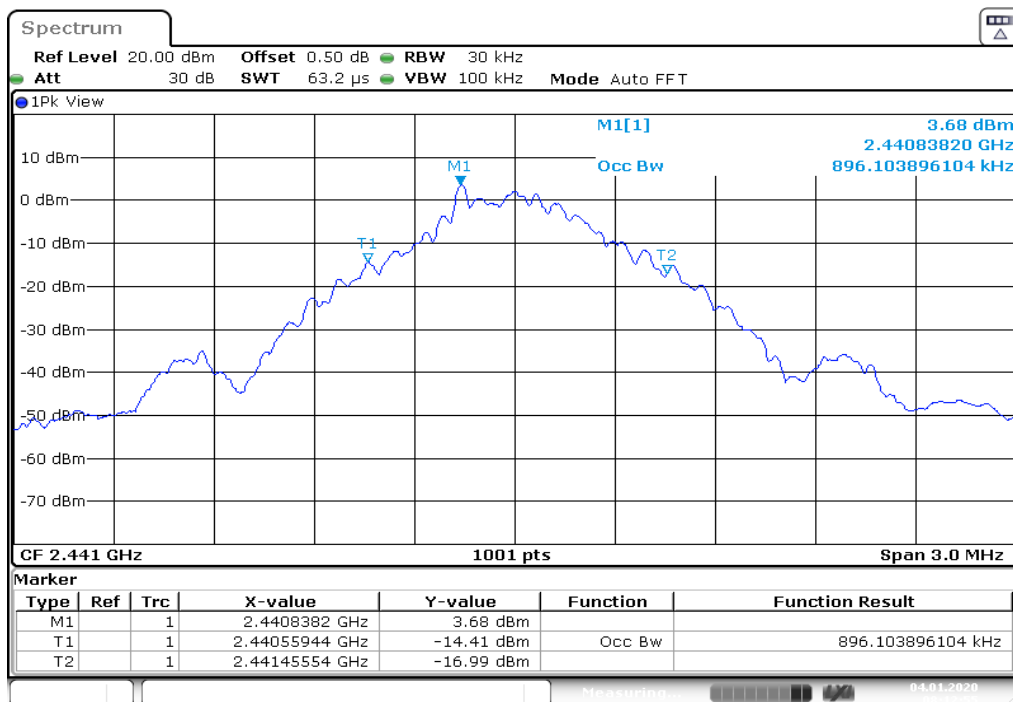
Test Plot of 99% Bandwidth, ANT 1M
Middle Channel

Date: 4.JAN.2020 08:12:55

Test Plot of 6dB Bandwidth, Nordic Original 2M

Low Channel

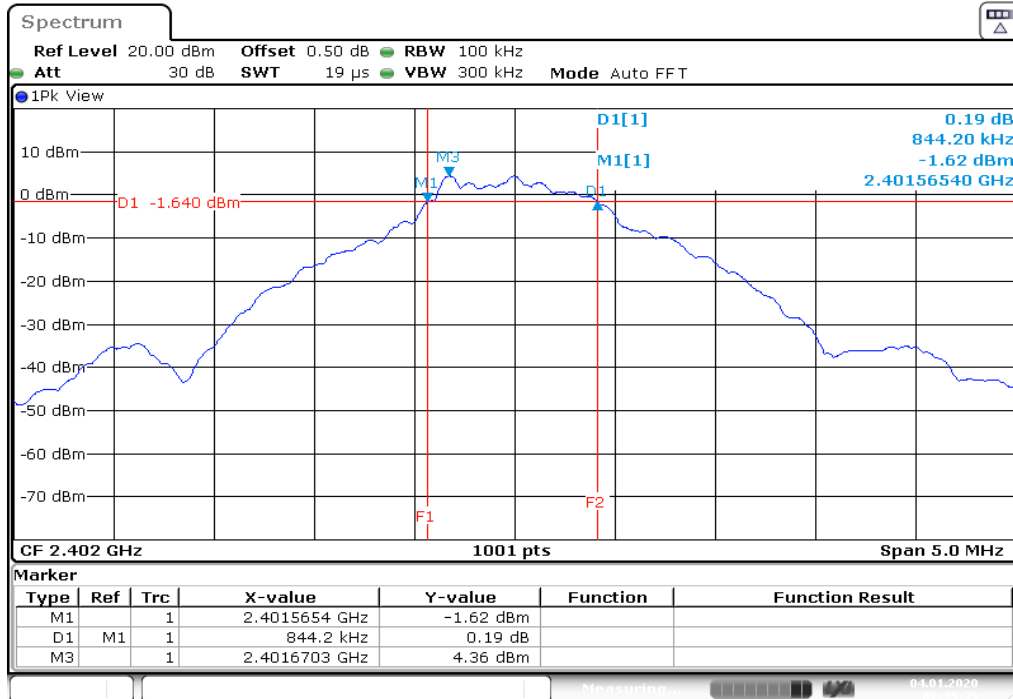

Date: 4.JAN.2020 07:49:40

Middle Channel

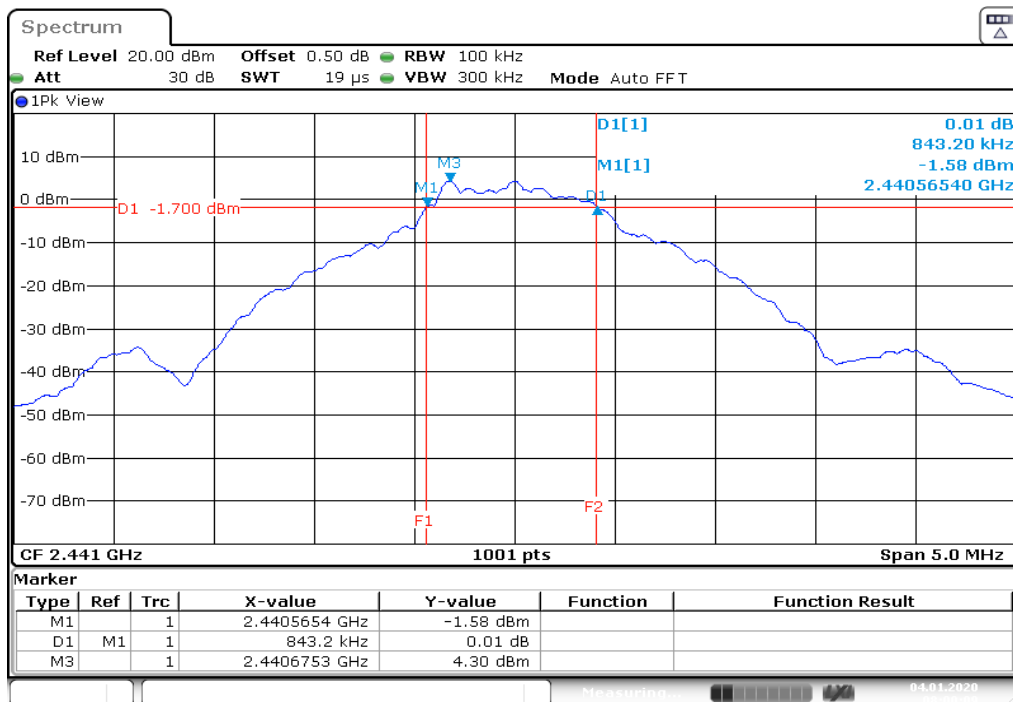

Date: 4.JAN.2020 08:00:10

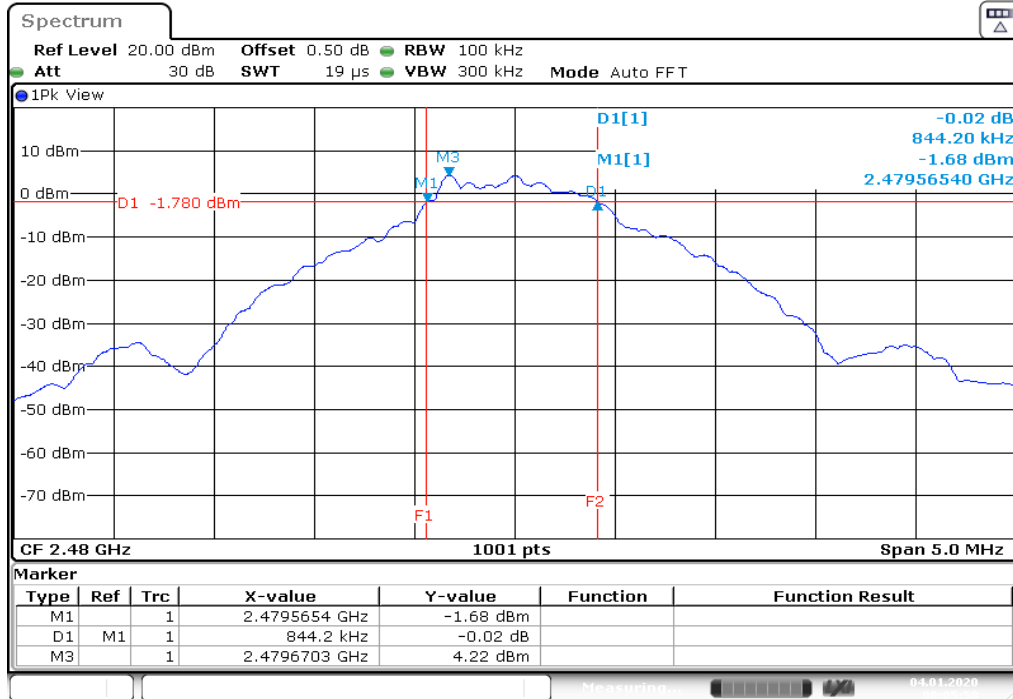
High Channel

Date: 4.JAN.2020 08:05:57

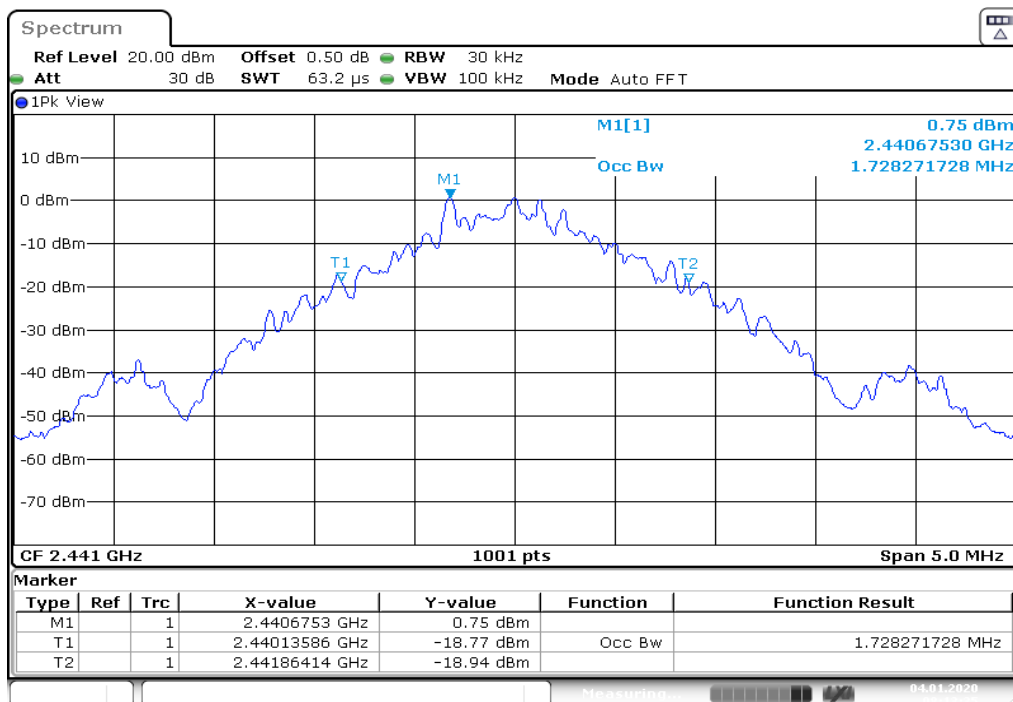
Test Plot of 99% Bandwidth, Nordic Original 2M
Middle Channel

Date: 4.JAN.2020 08:13:34

Test Plot of 6dB Bandwidth, IEEE 802.15.4

Low Channel

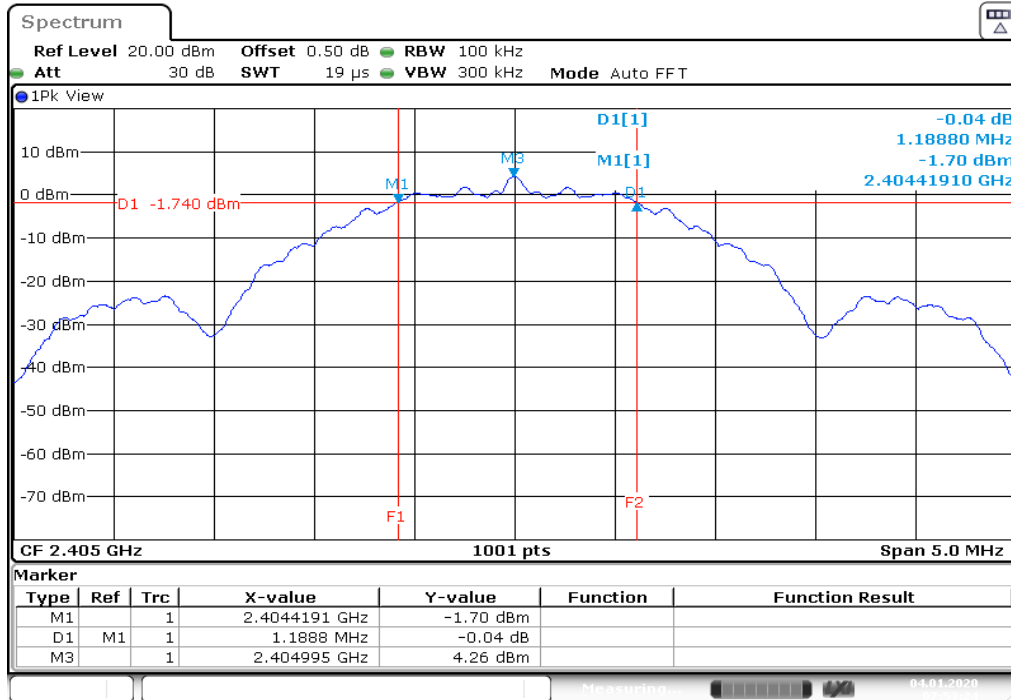

Date: 4.JAN.2020 07:53:25

Middle Channel

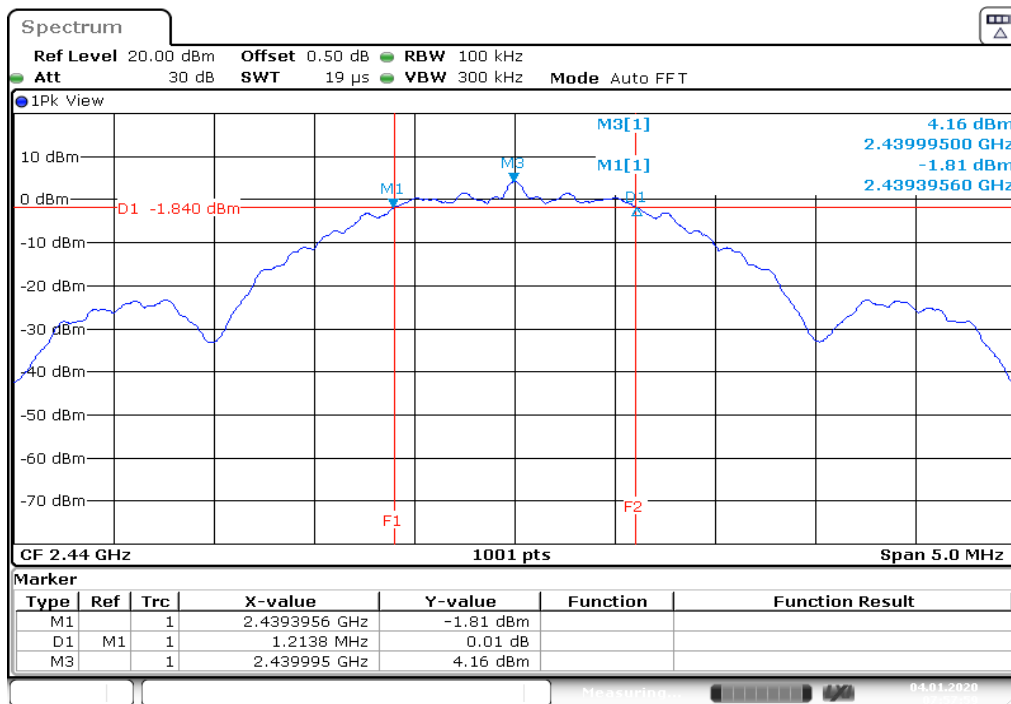

Date: 4.JAN.2020 07:58:00

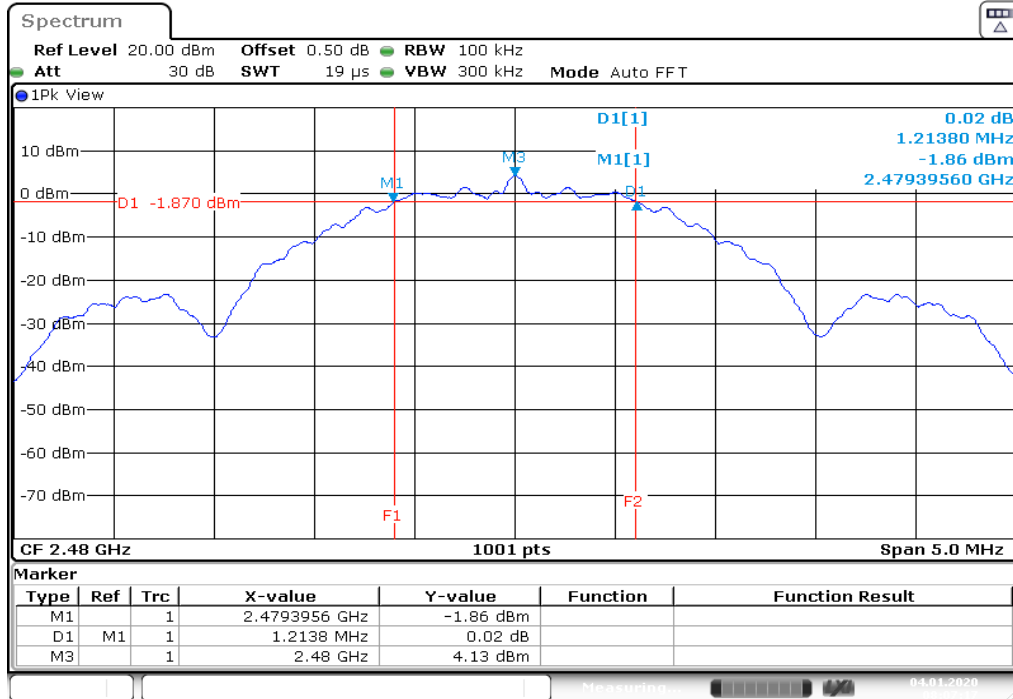
High Channel

Date: 4.JAN.2020 08:07:16

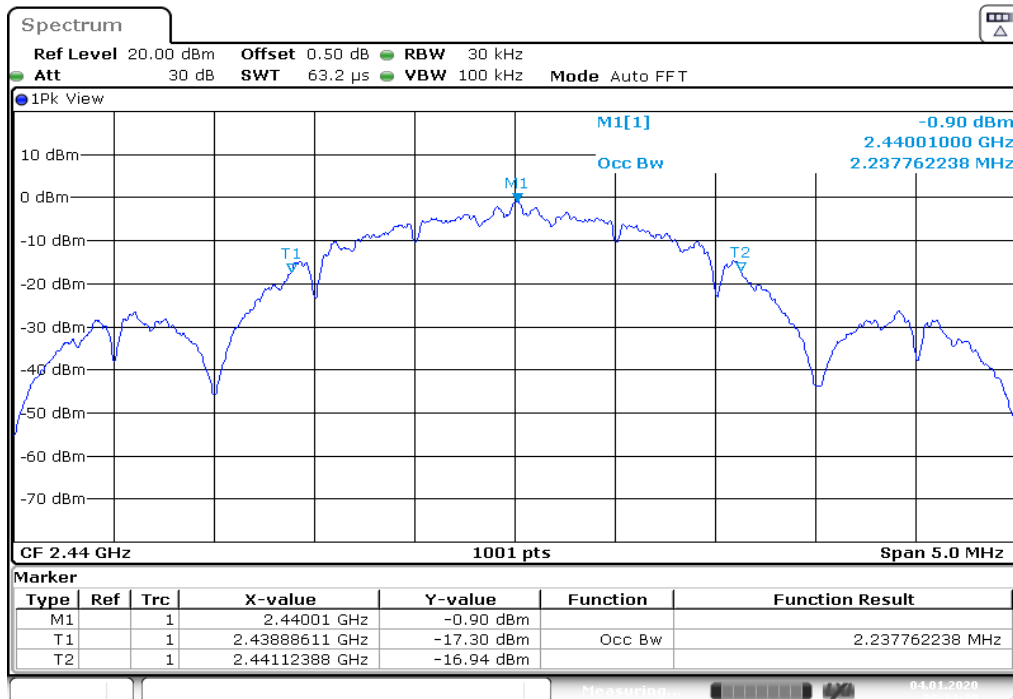
Test Plot of 99% Bandwidth, IEEE 802.15.4
Middle Channel

Date: 4.JAN.2020 08:14:20

5.1.4 Power Density

RESULT:
Passed

Test standard : FCC Part 15.247(e) , ISED RSS-247 5.2(b)
 Basic standard : ANSI C63.10:2013, KDB558074
 Kind of test site : Shielded room

Test setup

Test Channel : Low/ Middle/ High
 Operation Mode : A
 Ambient temperature : 20-24°C
 Relative humidity : 50-65%
 Atmospheric pressure : 100-103 kPa

Table 23: Test result of Power Density, LE 1M

Channel	Channel Frequency (MHz)	Power Density	Limit
		(dBm)	(dBm)
Low Channel	2402	-11.33	8
Middle Channel	2440	-11.41	8
High Channel	2480	-11.50	8

Table 24: Test result of Power Density, LE 2M

Channel	Channel Frequency (MHz)	Power Density	Limit
		(dBm)	(dBm)
Low Channel	2402	-13.72	8
Middle Channel	2440	-13.84	8
High Channel	2480	-14.08	8

Table 25: Test result of Power Density, ANT 1M

Channel	Channel Frequency (MHz)	Power Density	Limit
		(dBm)	(dBm)
Low Channel	2402	-7.44	8
Middle Channel	2441	-7.50	8
High Channel	2480	-7.59	8

Table 26: Test result of Power Density, Nordic Original 2M

Channel	Channel Frequency (MHz)	Power Density	Limit
		(dBm)	(dBm)
Low Channel	2402	-9.88	8
Middle Channel	2441	-10.13	8
High Channel	2480	-10.22	8

Table 27: Test result of Power Density, IEEE 802.15.4

Channel	Channel Frequency (MHz)	Power Density	Limit
		(dBm)	(dBm)
Low Channel	2405	-9.94	8
Middle Channel	2440	-10.15	8
High Channel	2480	-10.41	8

Test Plot of Power Density, LE 1M

Low Channel

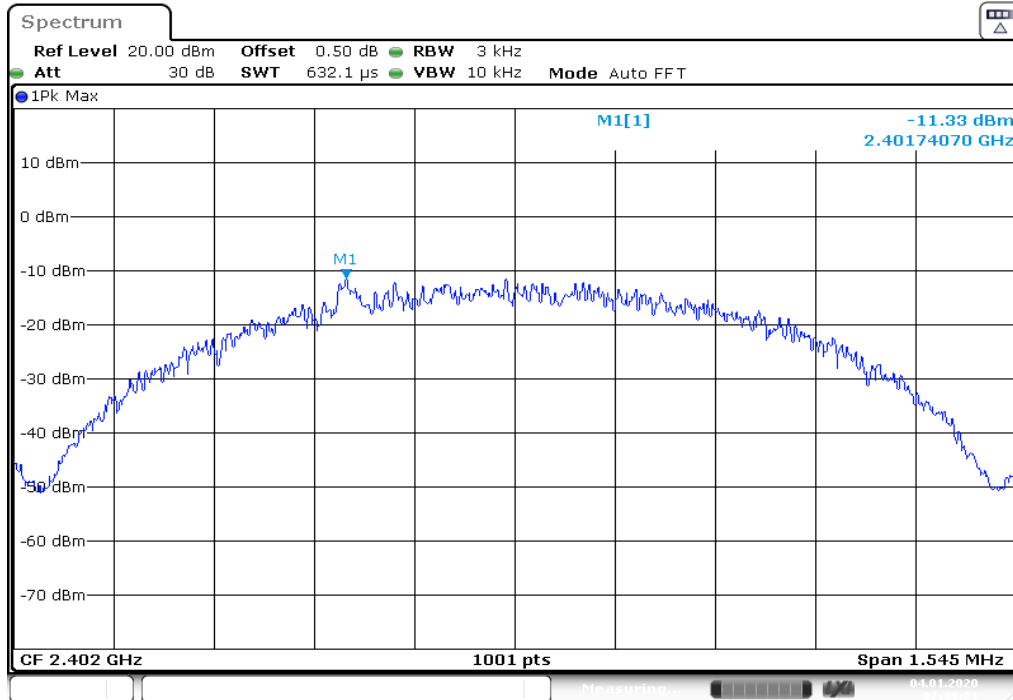

Middle Channel

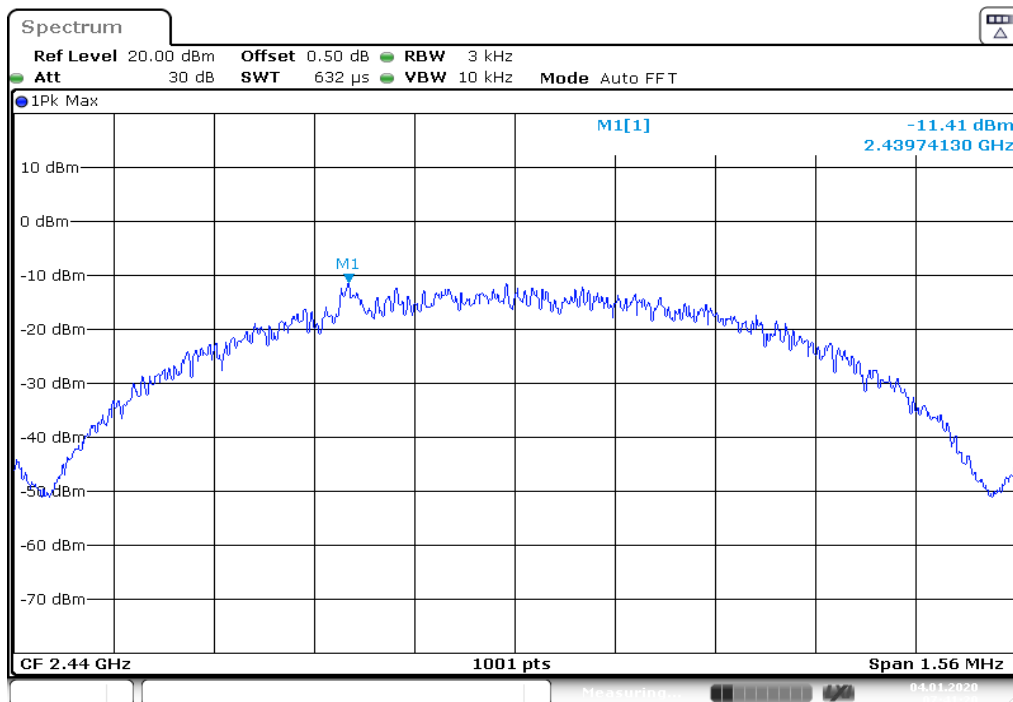

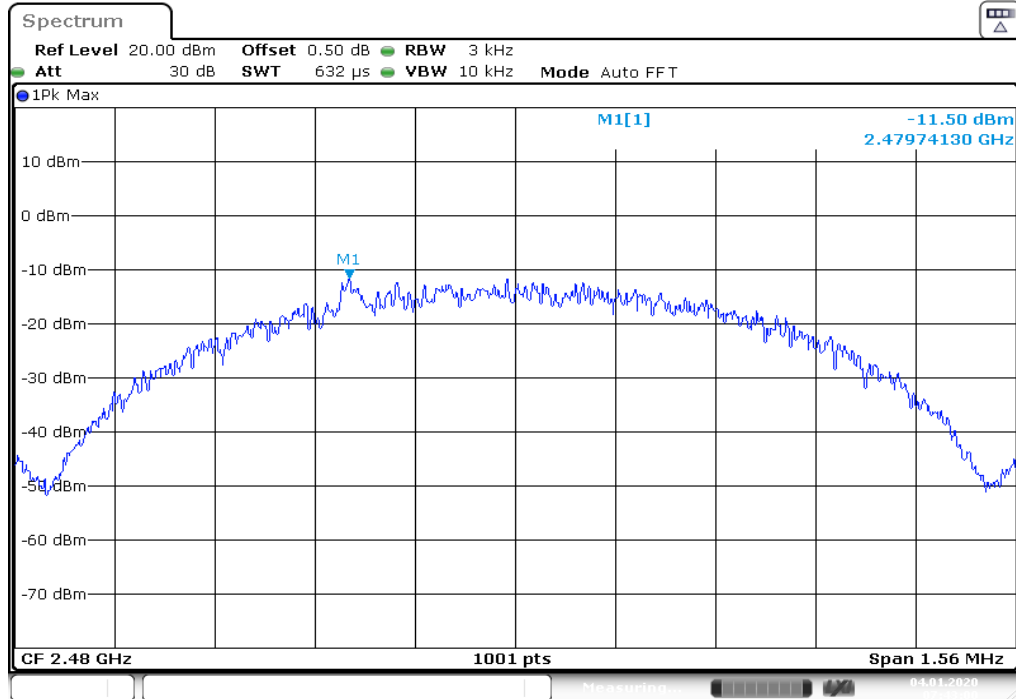
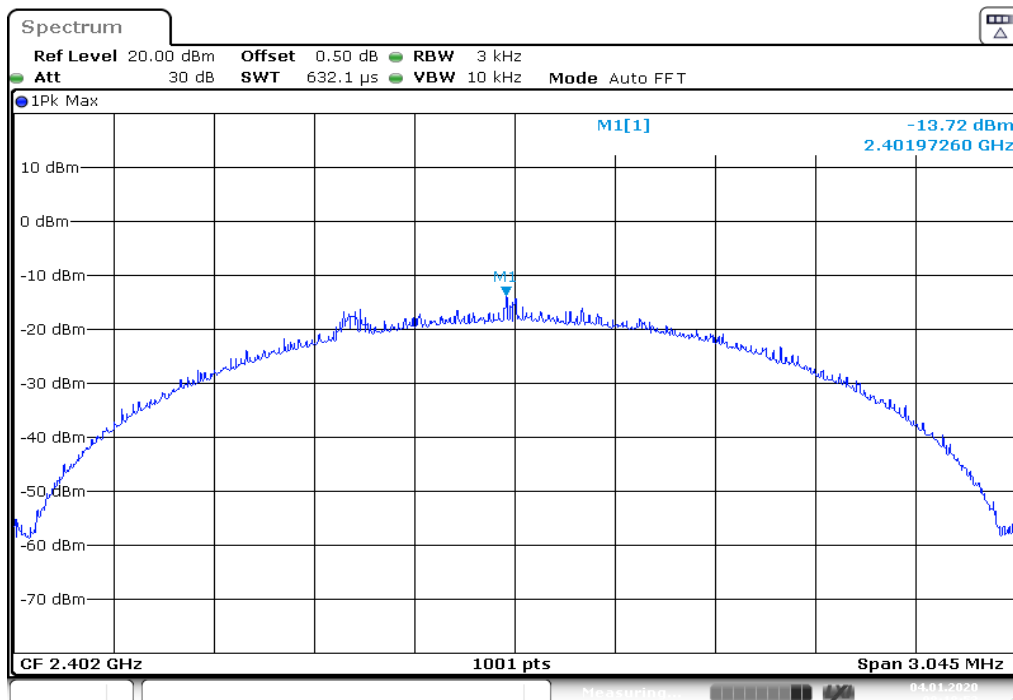
High Channel

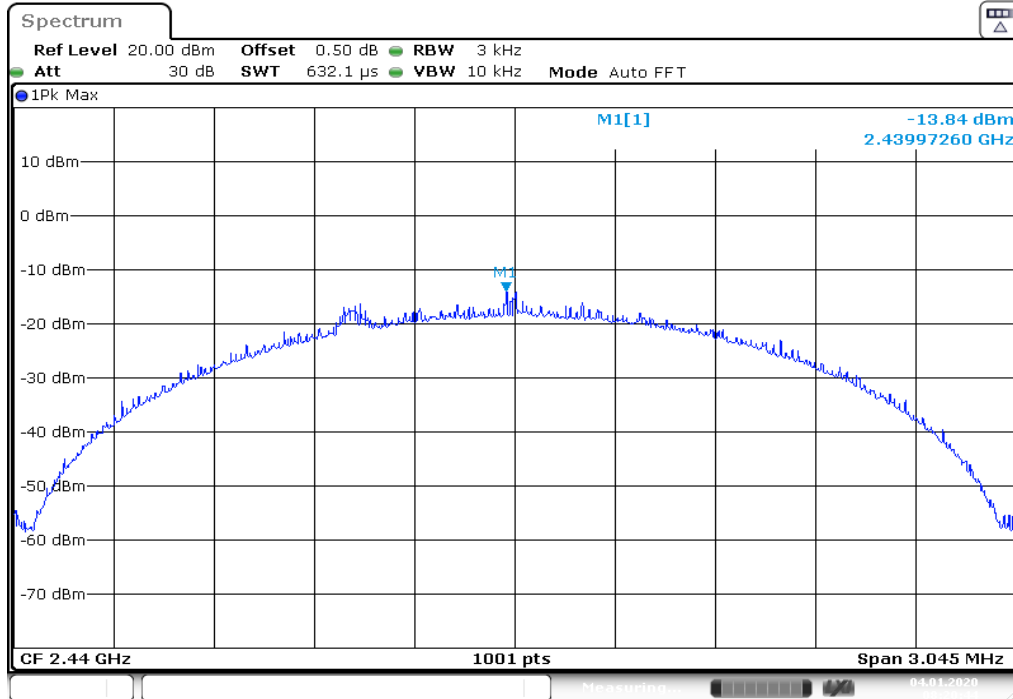
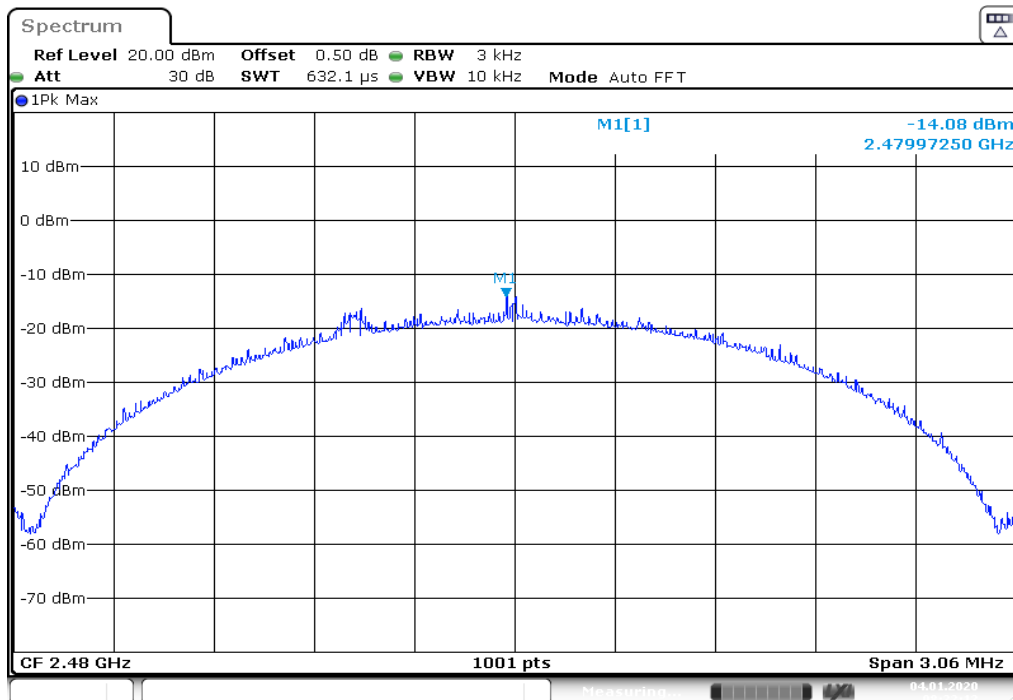
Test Plot of Power Density, LE 2M
Low Channel

Middle Channel

High Channel

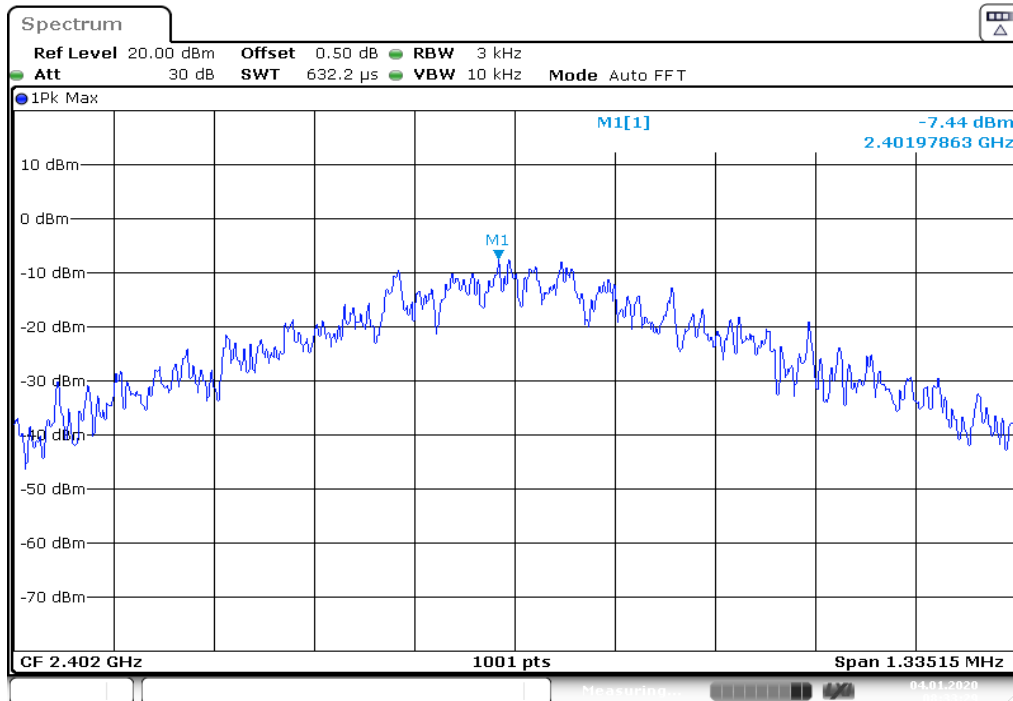
Test Plot of Power Density, ANT 1M

Low Channel

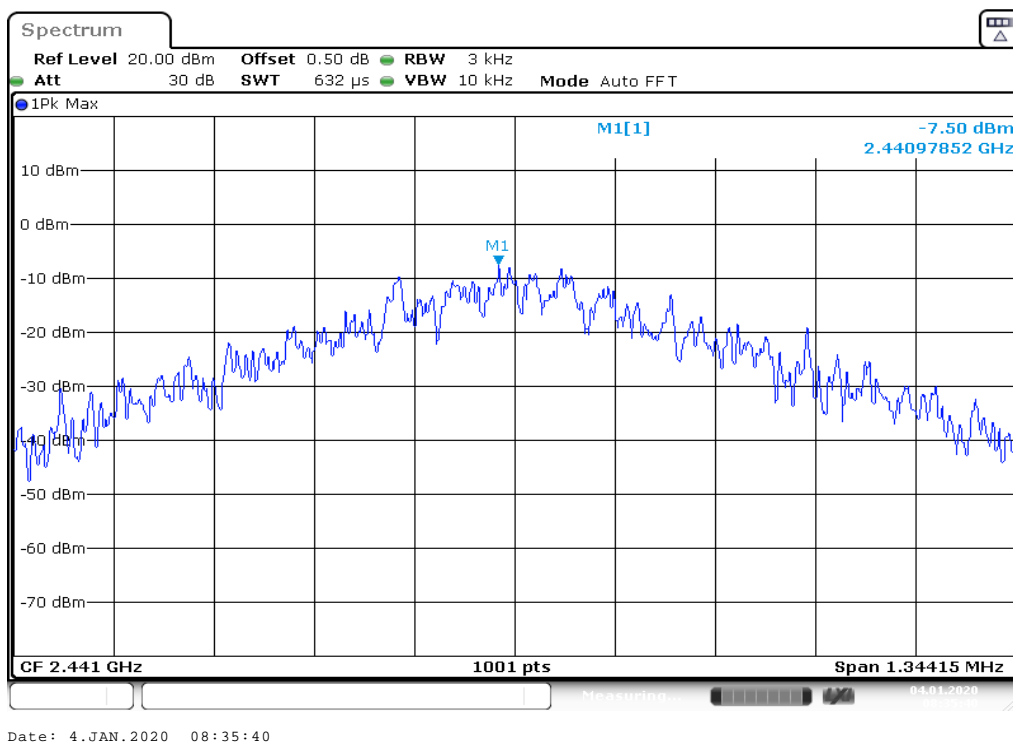

Middle Channel

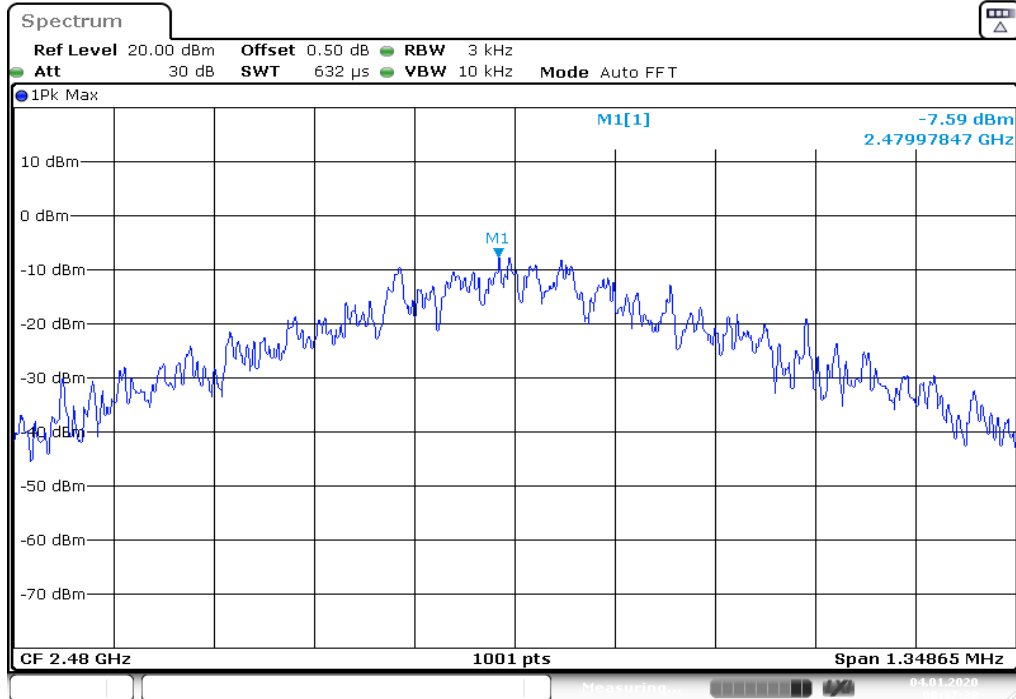
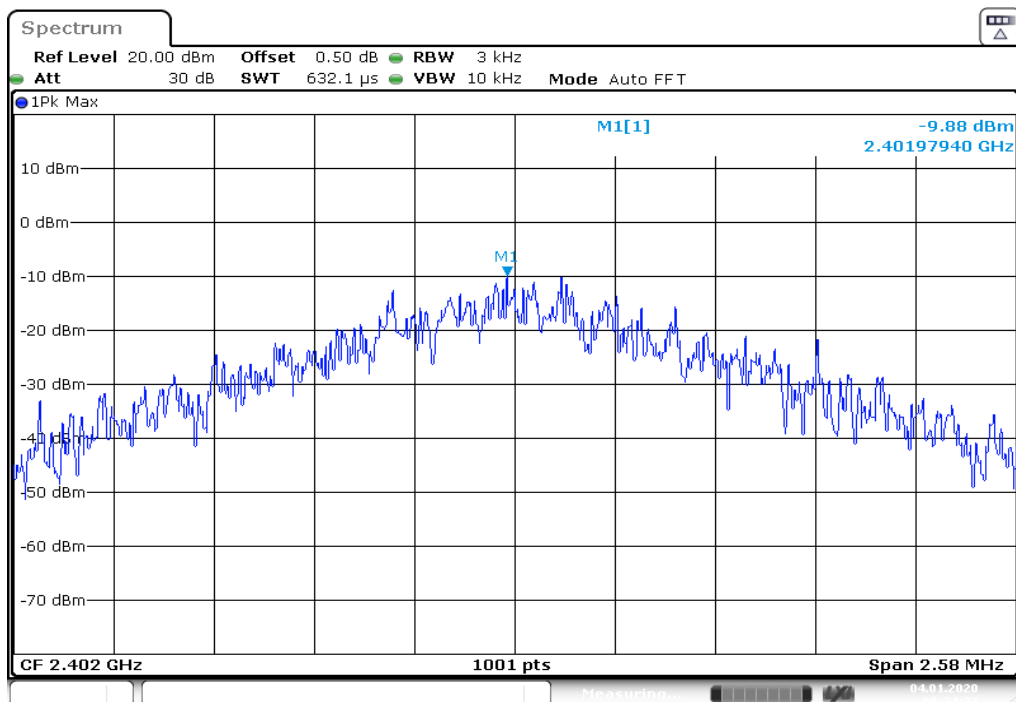

High Channel

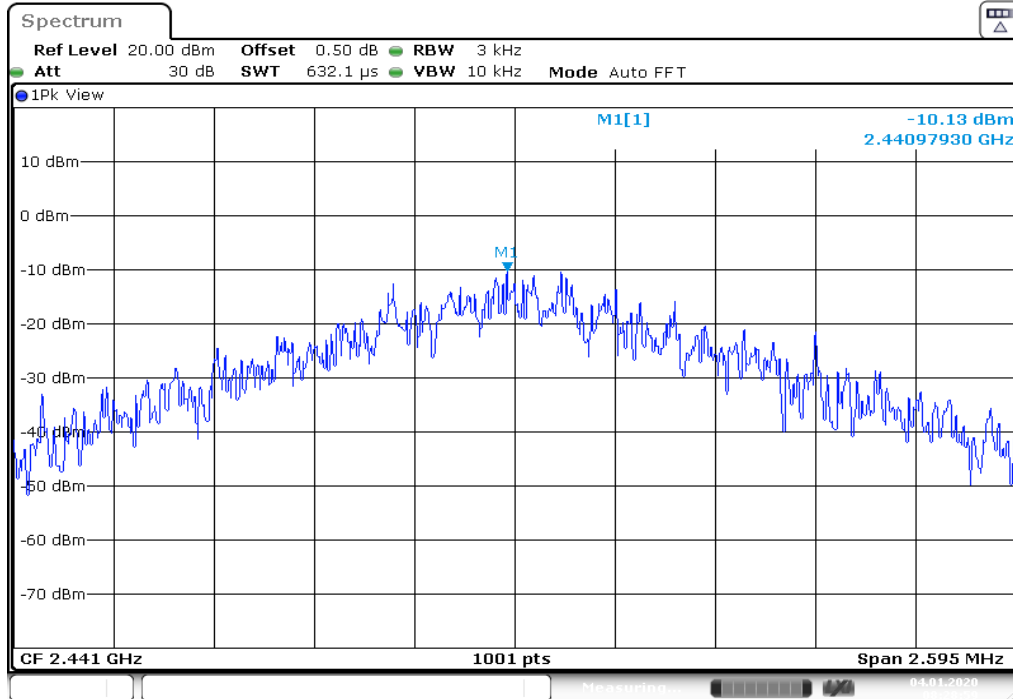
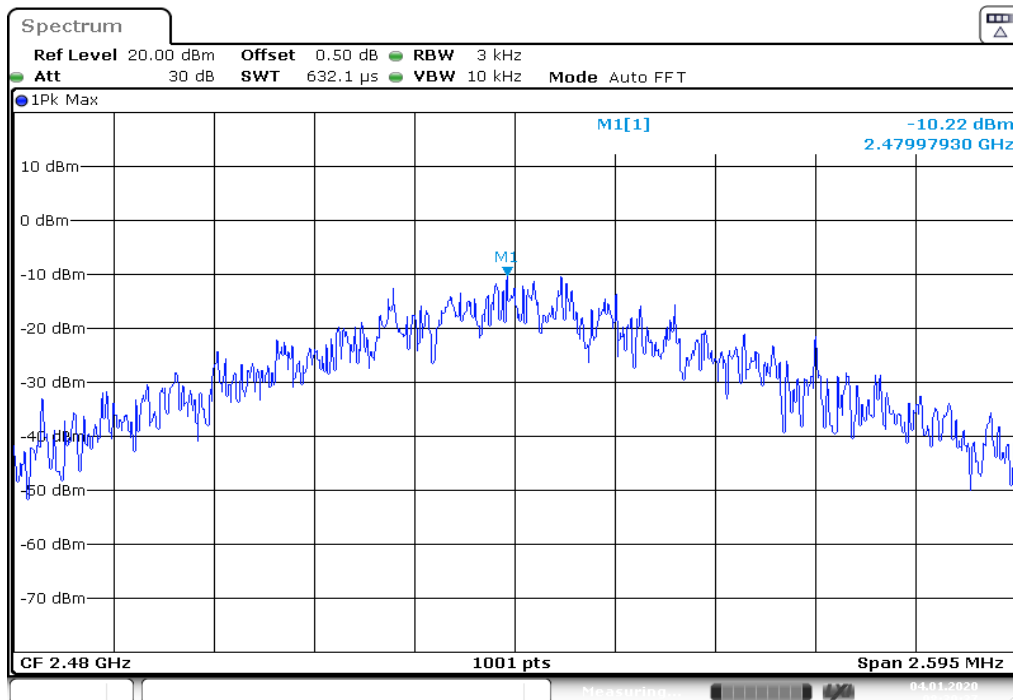
Test Plot of Power Density, Nordic Original 2M
Low Channel

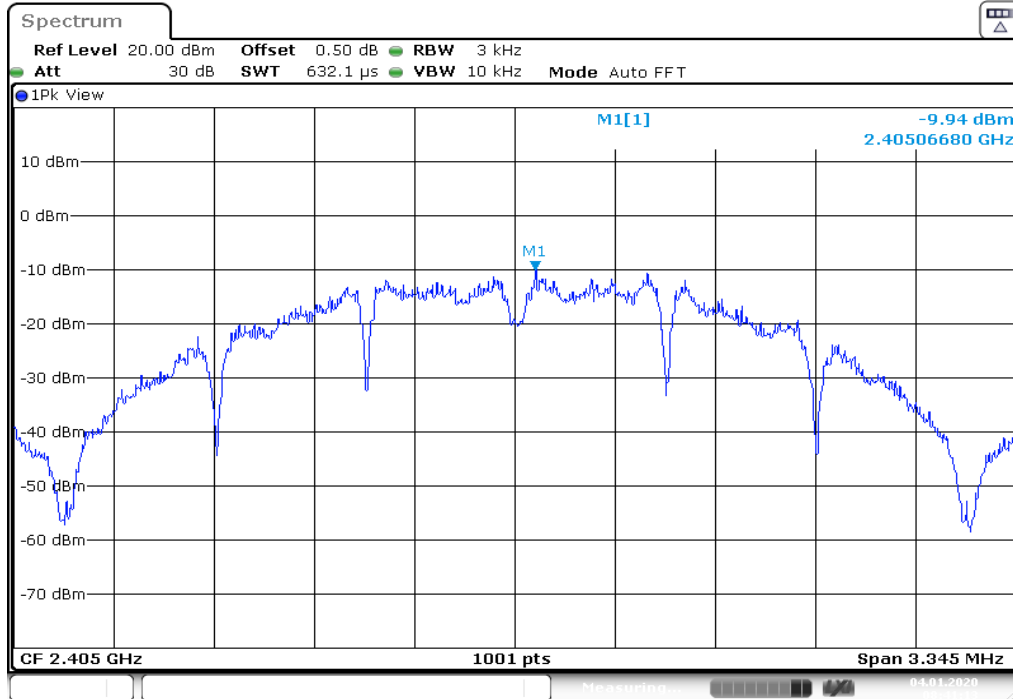
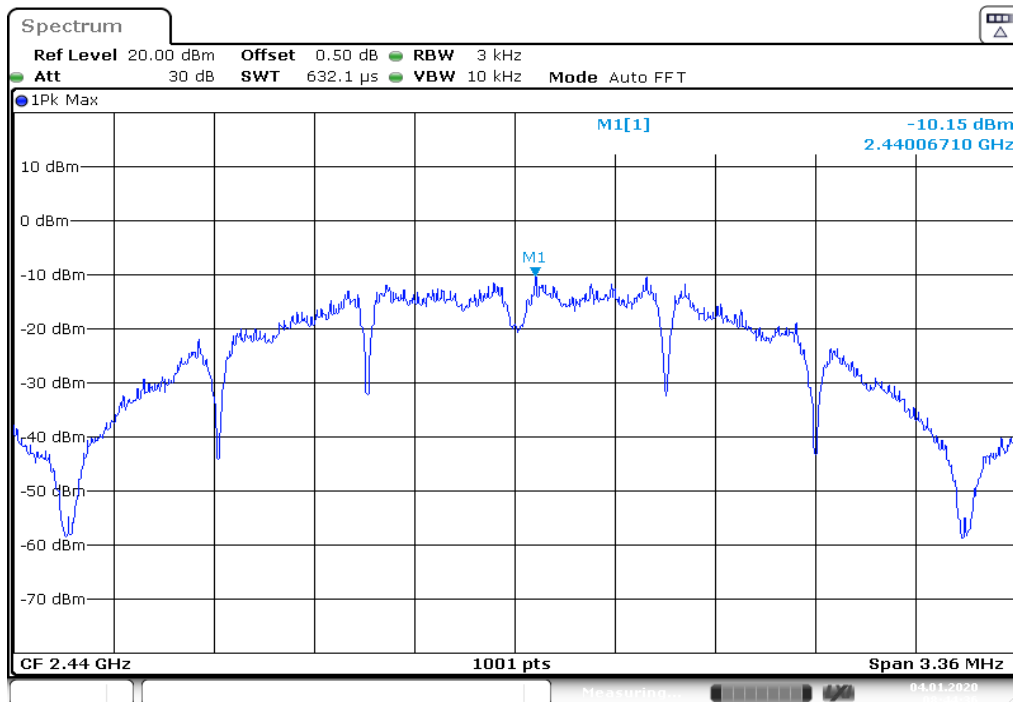
Middle Channel

High Channel

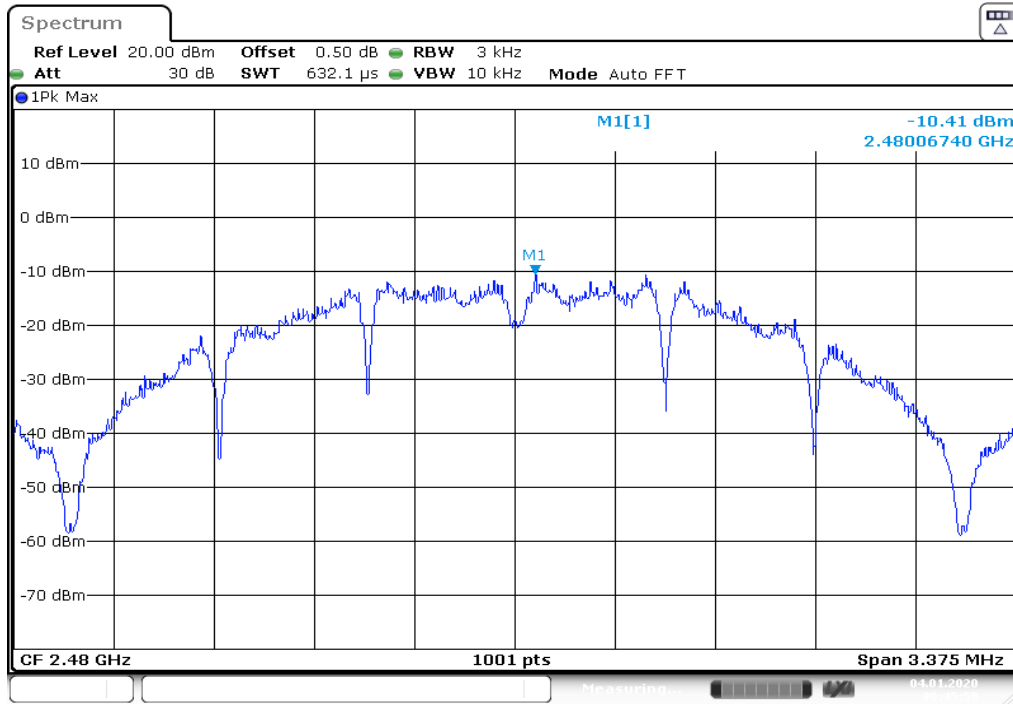
Test Plot of Power Density, IEEE 802.15.4
Low Channel

Middle Channel

High Channel



Date: 4.JAN.2020 08:45:58

Prüfbericht - Nr.: 50339907 001

Test Report No.

Seite 41 von 63

Page 41 of 63

5.1.5 Conducted spurious emissions and Frequency Band Edge measured in 100kHz Bandwidth

RESULT:**Passed**

Test standard	:	FCC part 15.247(d), ISED RSS-247 5.5
Basic standard	:	ANSI C63.10:2013, KDB558074
Limit	:	20dB (below that in the 100kHz bandwidth within the band that contains the highest level of the desired power)
Kind of test site	:	Shielded room

Test setup

Test Channel	:	Low/ Mid/ High for spurious, Low/ High for Band Edge
Operation mode	:	A
Ambient temperature	:	20-24°C
Relative humidity	:	50-65%
Atmospheric pressure	:	100-103 kPa

All emissions are more than 20dB below fundamental, details refer to following test plot, and compliance is achieved as well.

Due to the small size of the product and that there are no inductive components of significant size, 9kHz to 30MHz frequency range is not tested based on technical judgment.

Test Plot 100kHz Conducted Emissions, LE 1M

Low Channel

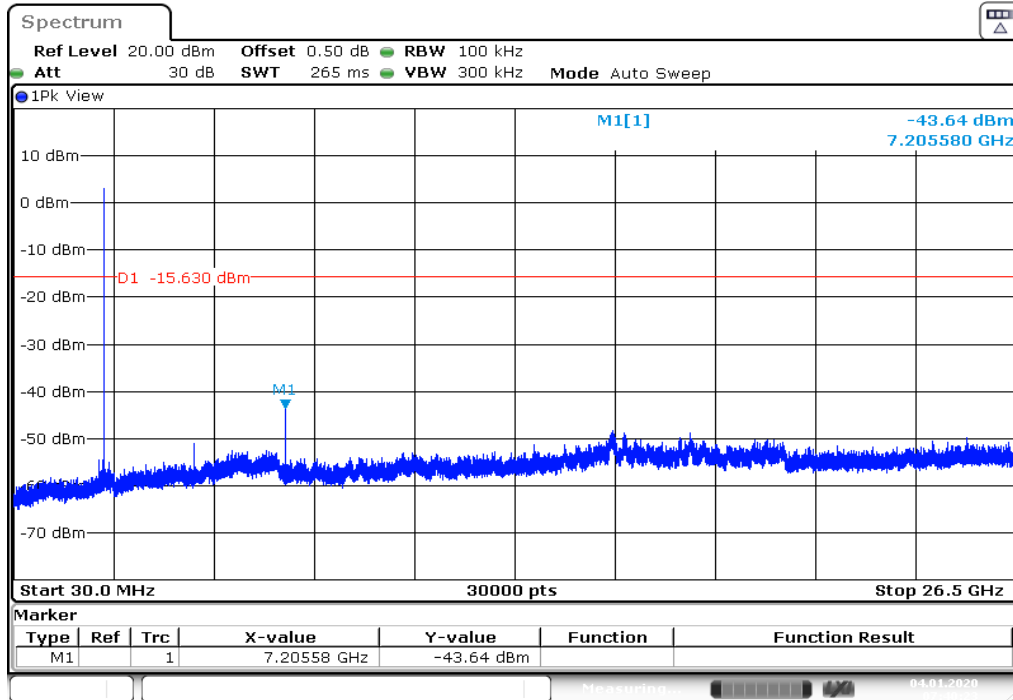

Date: 4.JAN.2020 07:40:23

Middle Channel

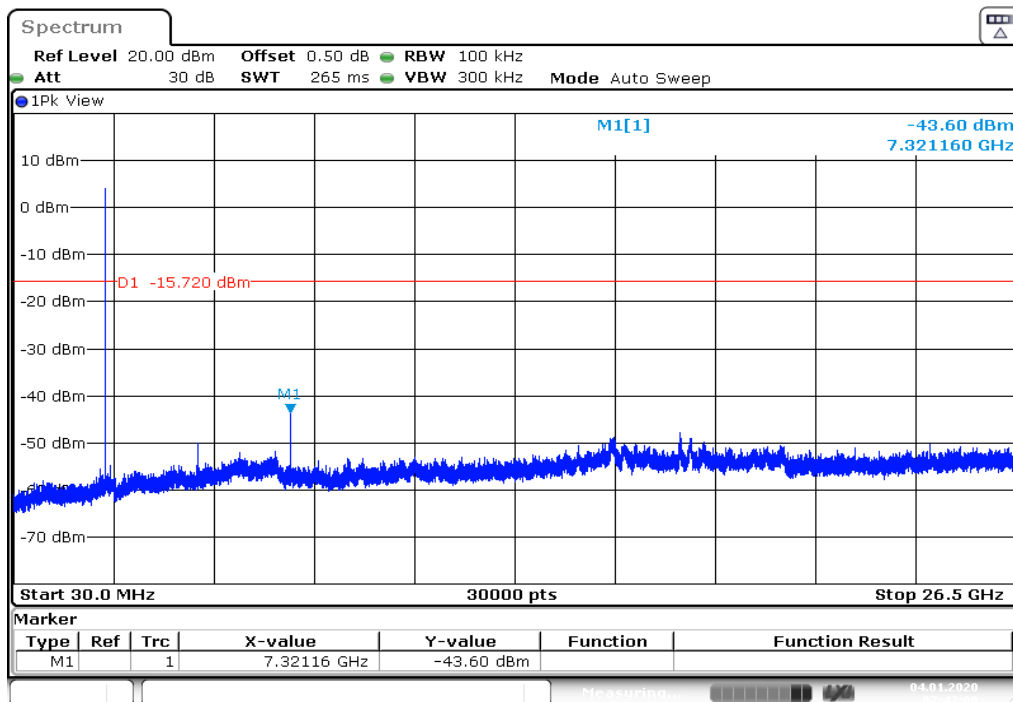

Date: 4.JAN.2020 07:42:08

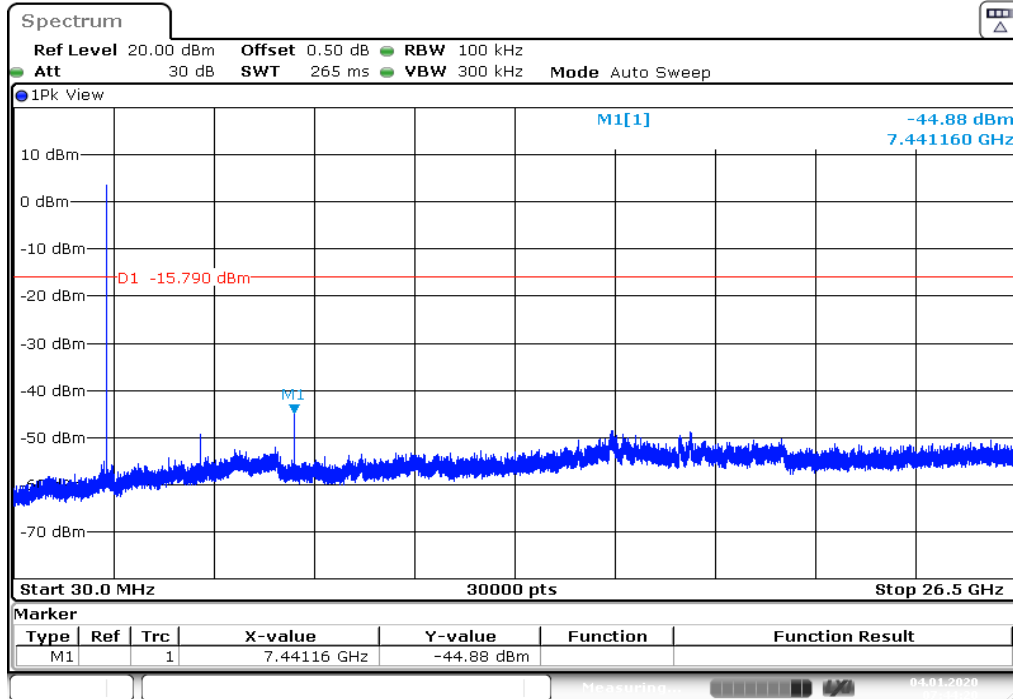
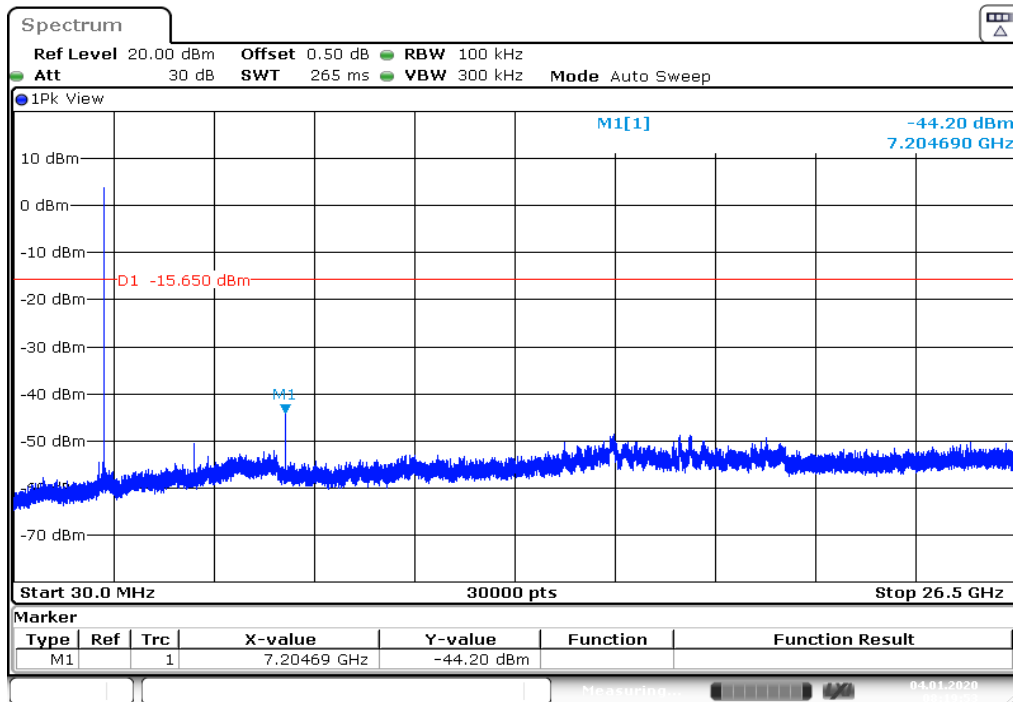
High Channel

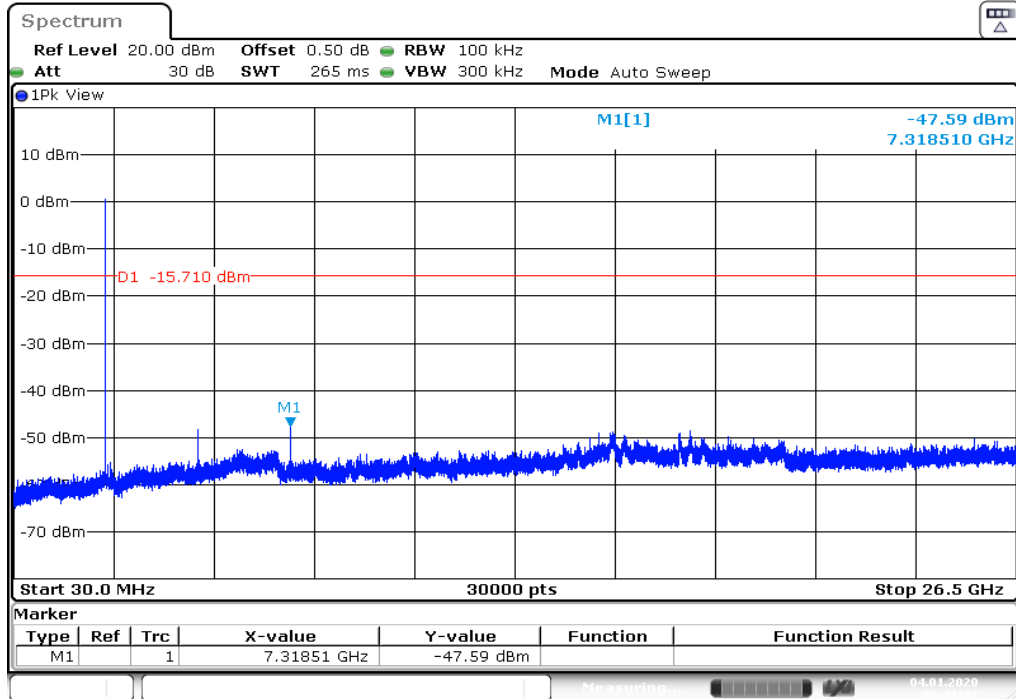
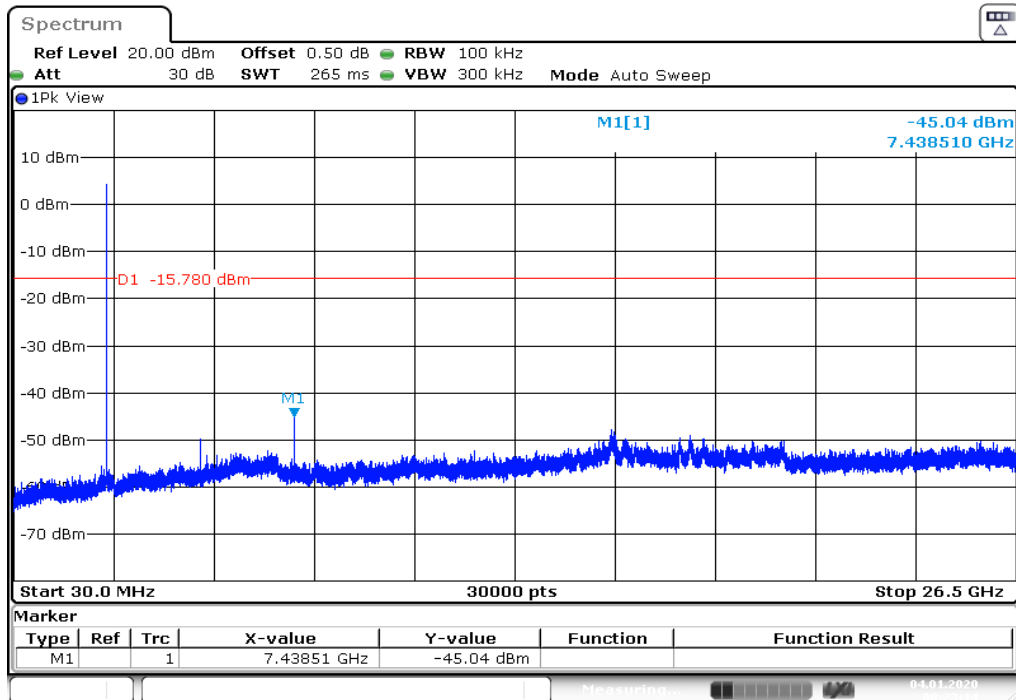
Test Plot 100kHz Conducted Emissions, LE 2M
Low Channel

Middle Channel

High Channel

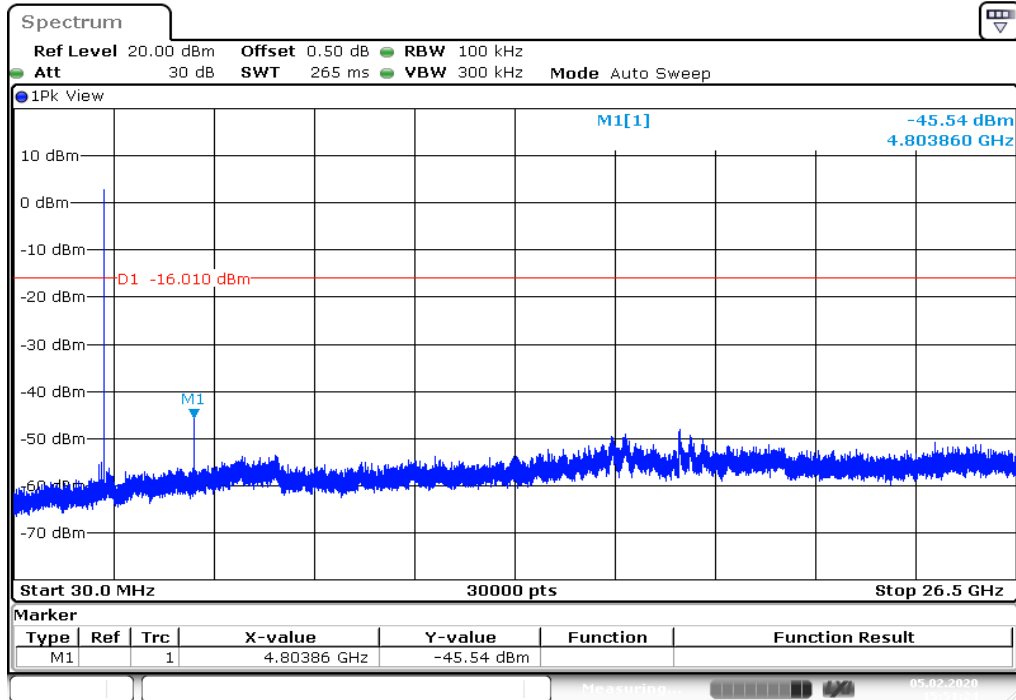
Test Plot 100kHz Conducted Emissions, ANT 1M

Low Channel

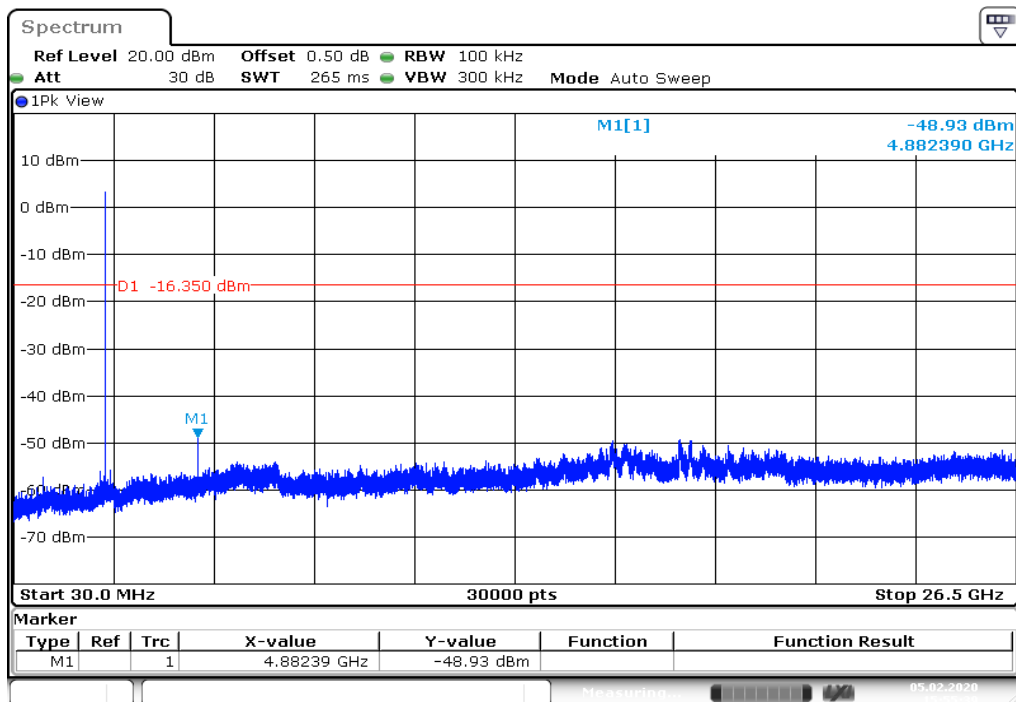

Middle Channel

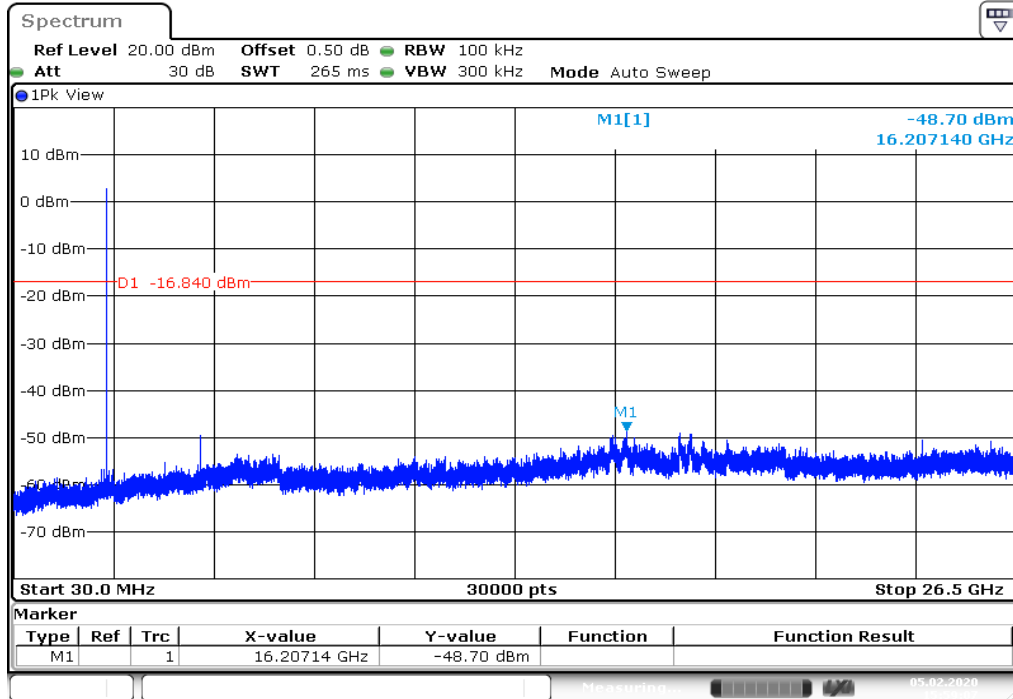
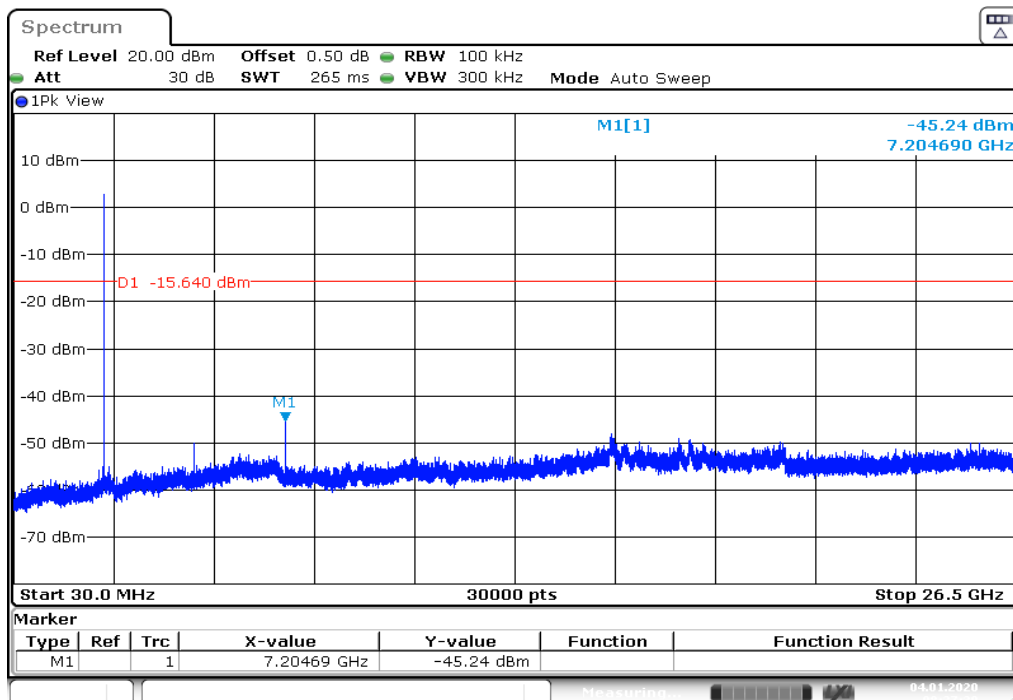

High Channel

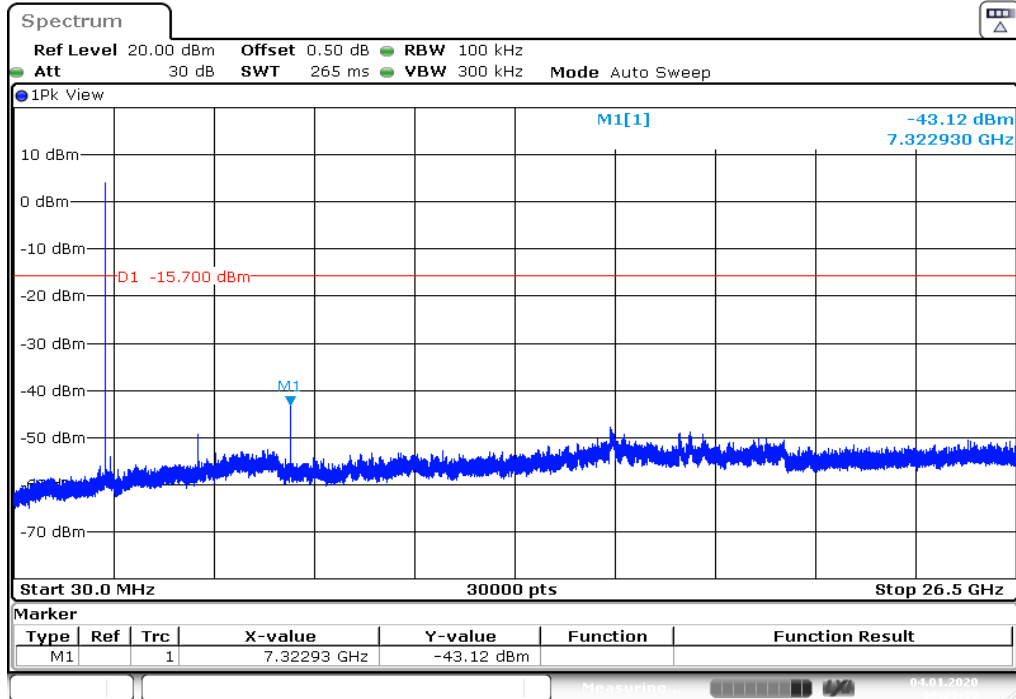
Test Plot 100kHz Conducted Emissions, Nordic Original 2M
Low Channel

Middle Channel

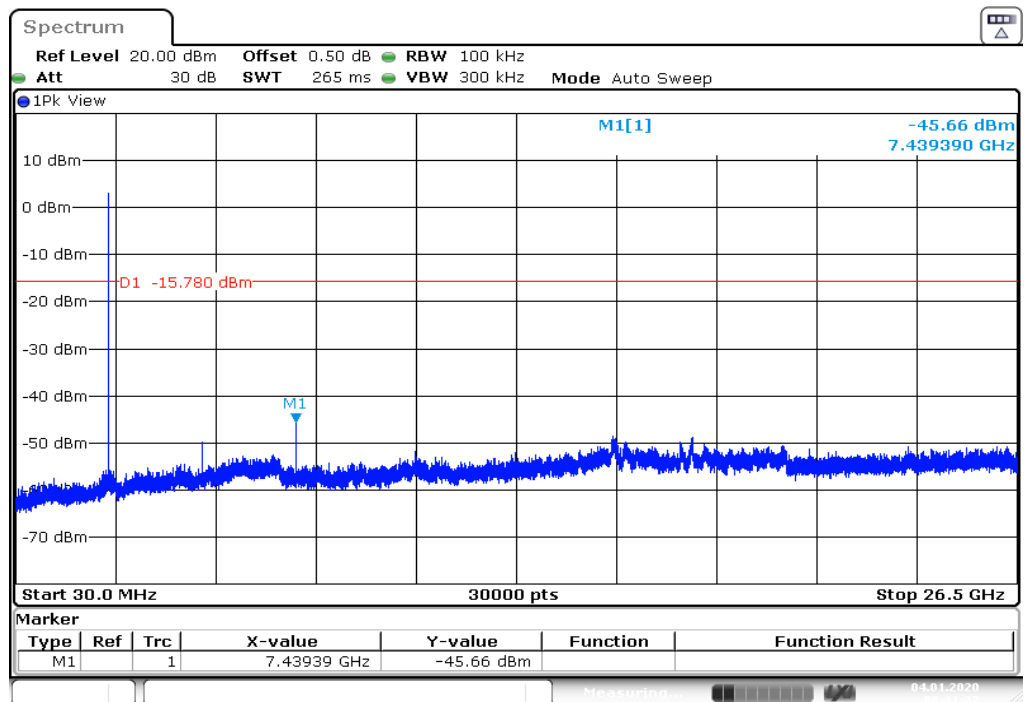
Date: 4.JAN.2020 08:29:39

High Channel

Date: 4.JAN.2020 08:31:37

Test Plot 100kHz Conducted Emissions, IEEE 802.15.4

Low Channel

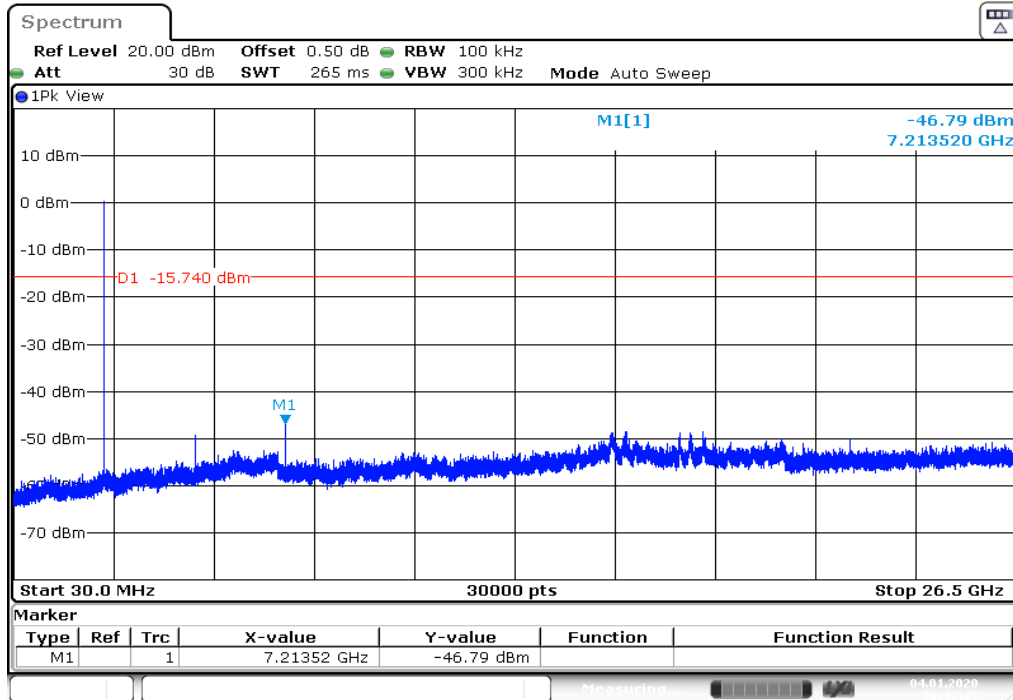

Middle Channel

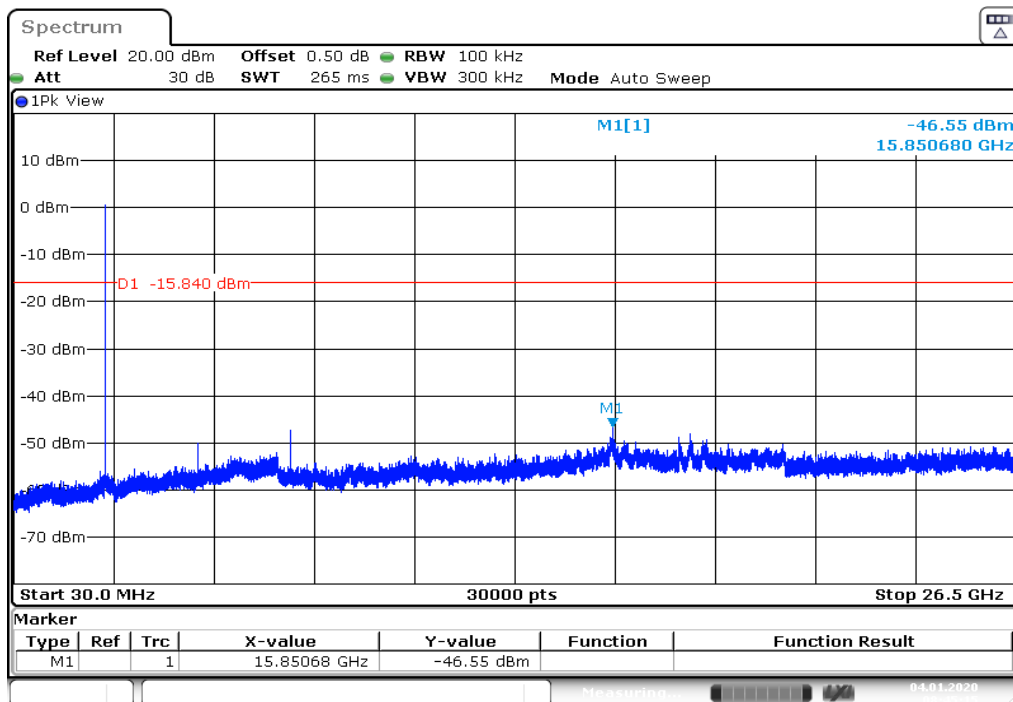

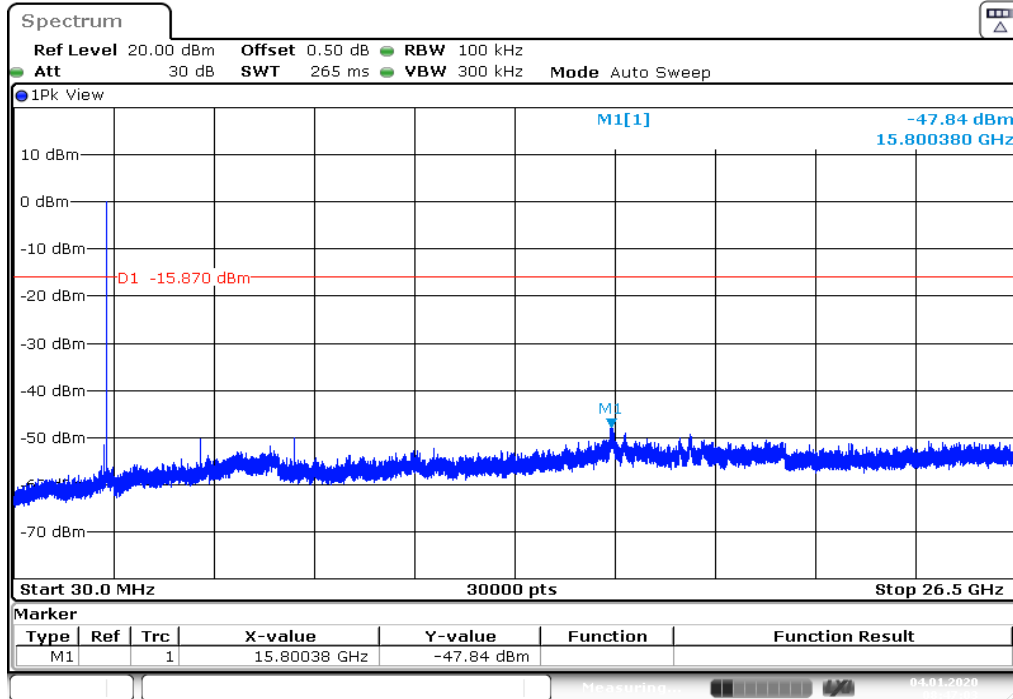
High Channel

Date: 4.JAN.2020 08:47:03

Test Plot 100kHz RBW of Band Edge, LE 1M

Low Channel

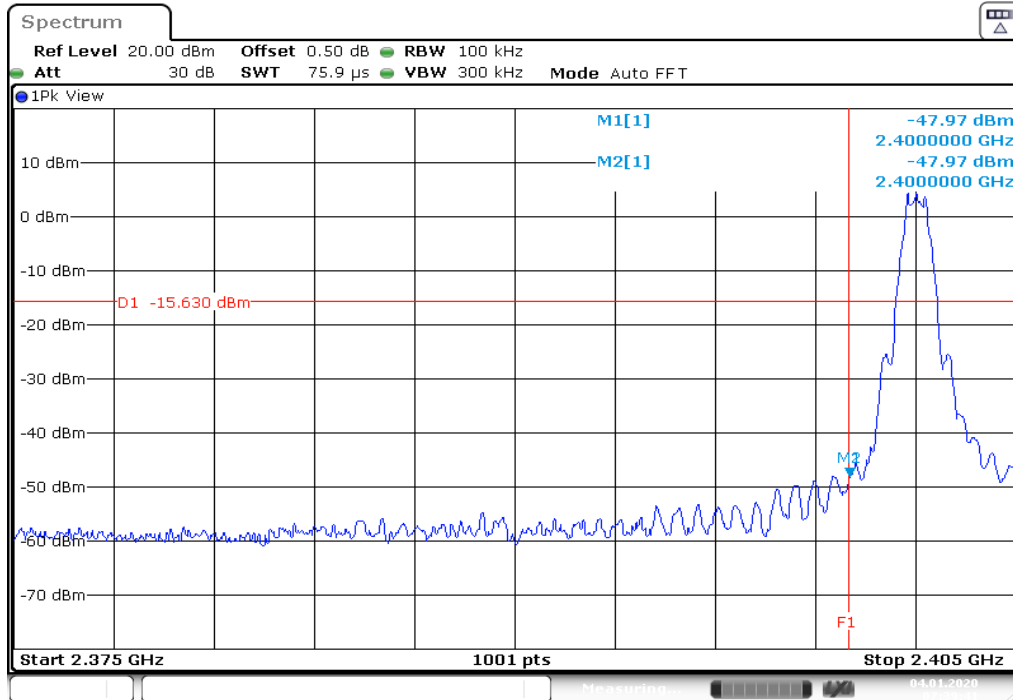

High Channel

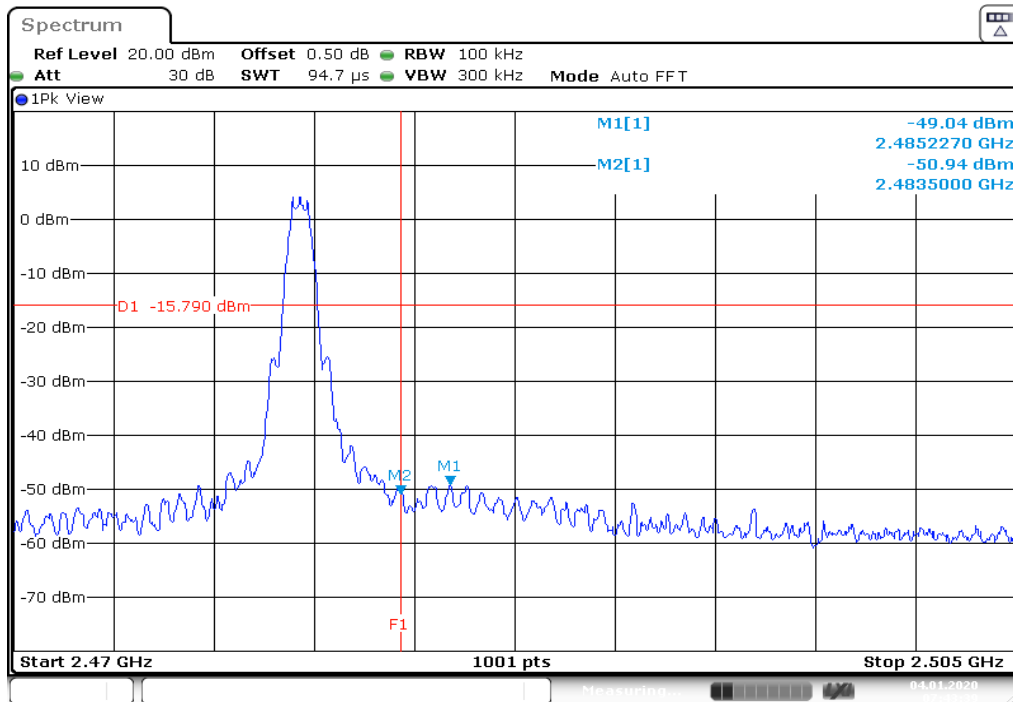

Test Plot 100kHz RBW of Band Edge, LE 2M

Low Channel

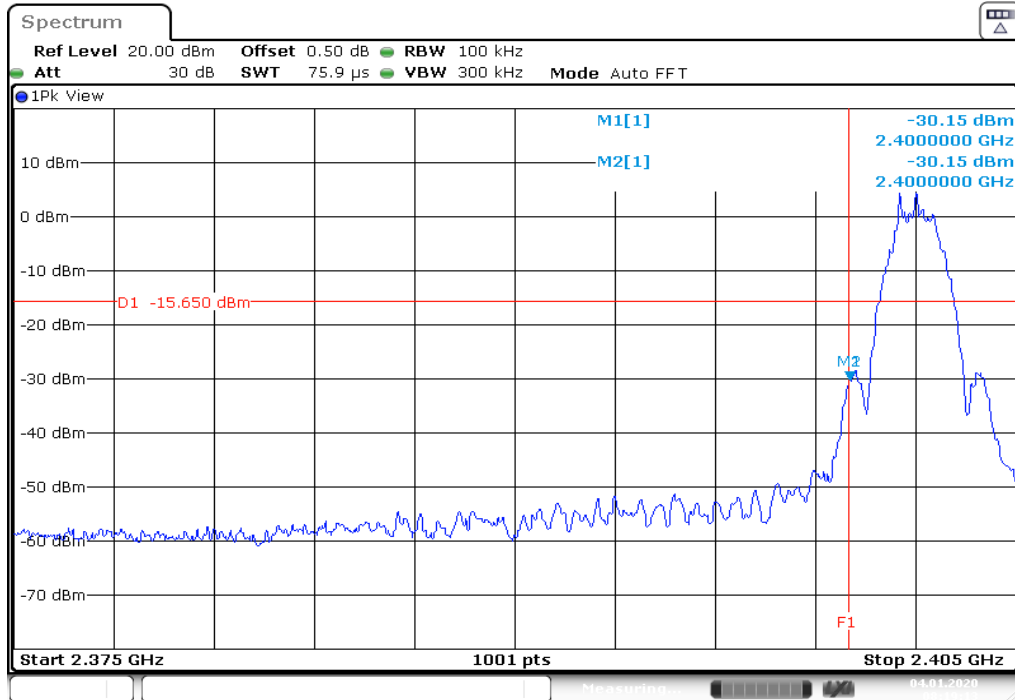

High Channel

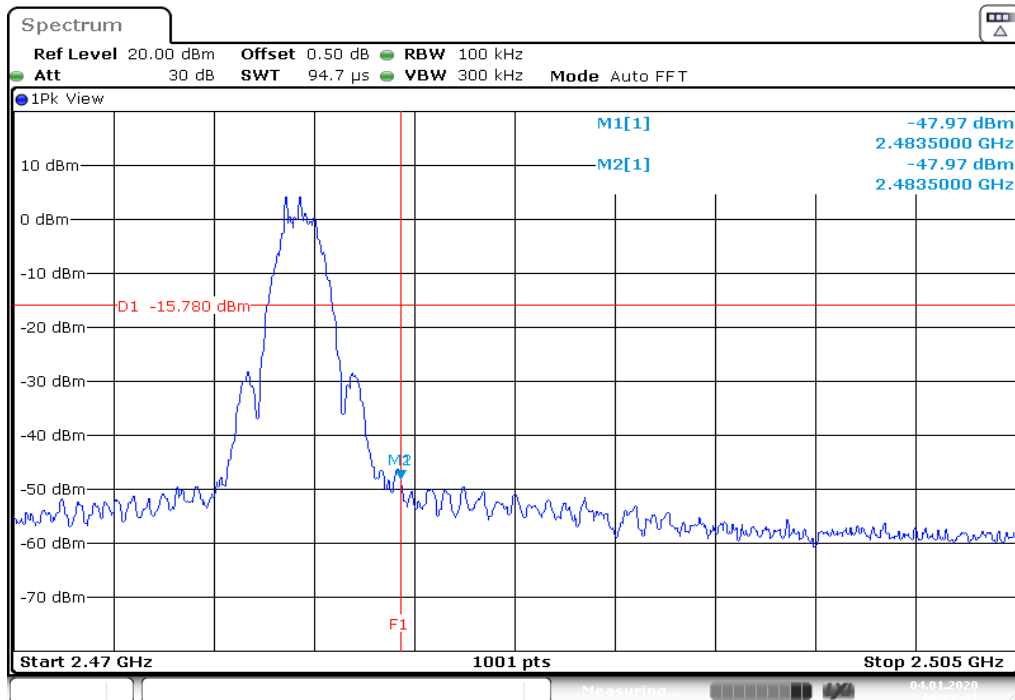

Test Plot 100kHz RBW of Band Edge, ANT 1M

Low Channel

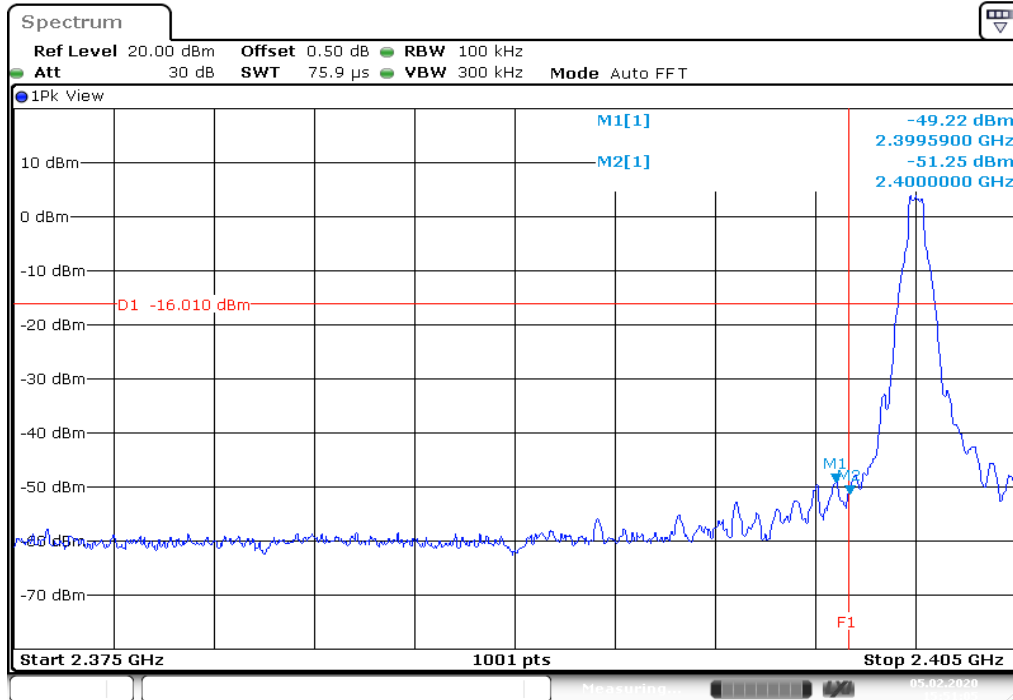

High Channel

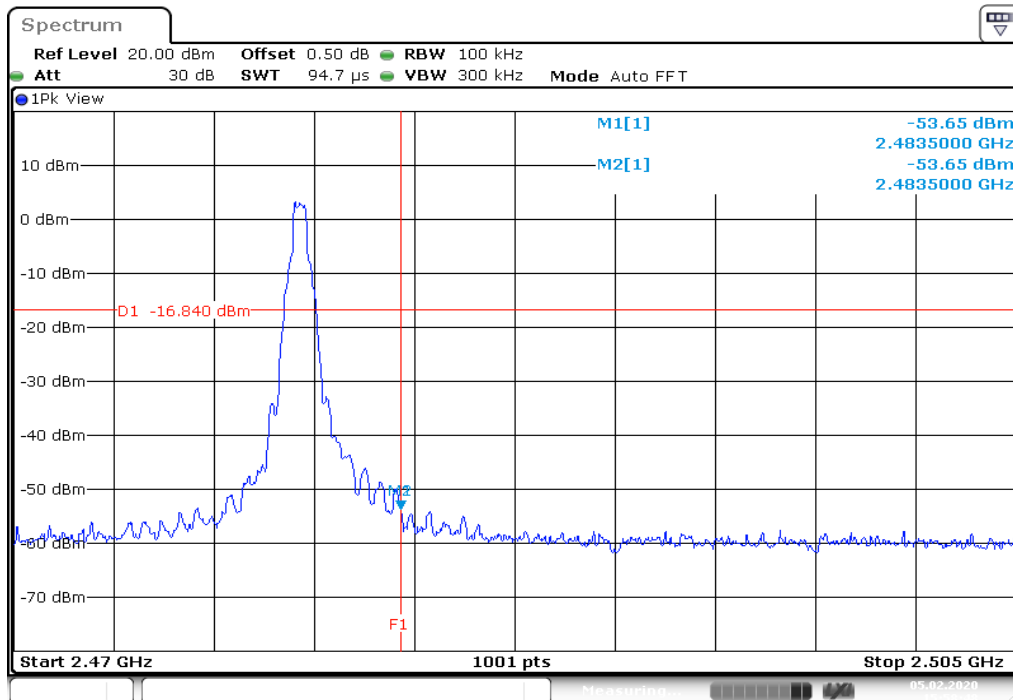

Test Plot 100kHz RBW of Band Edge, Nordic Original 2M

Low Channel

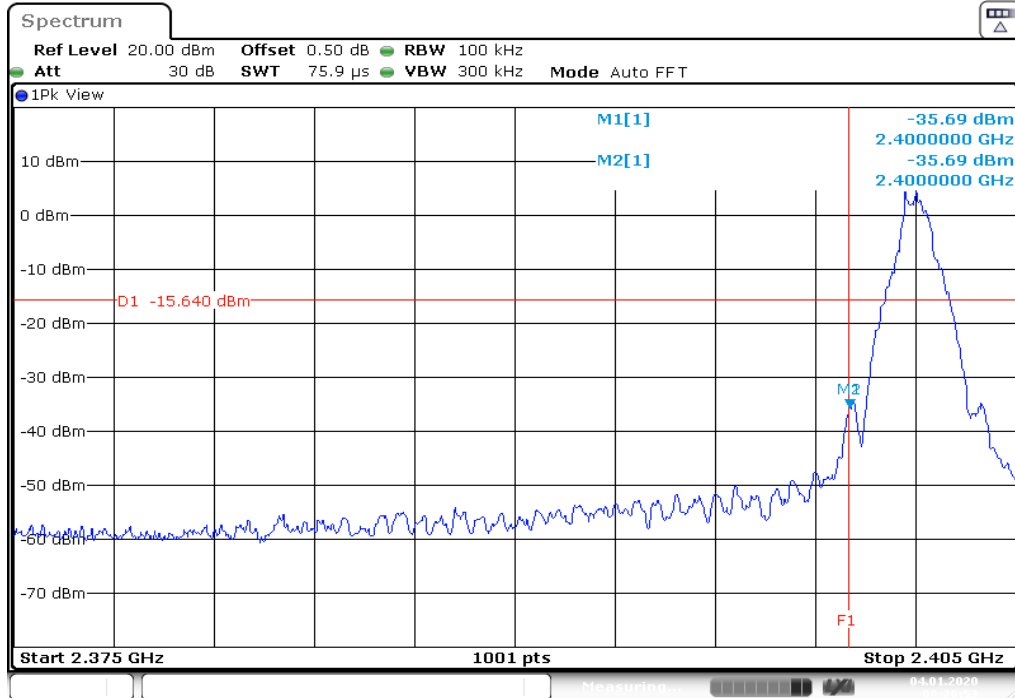

High Channel

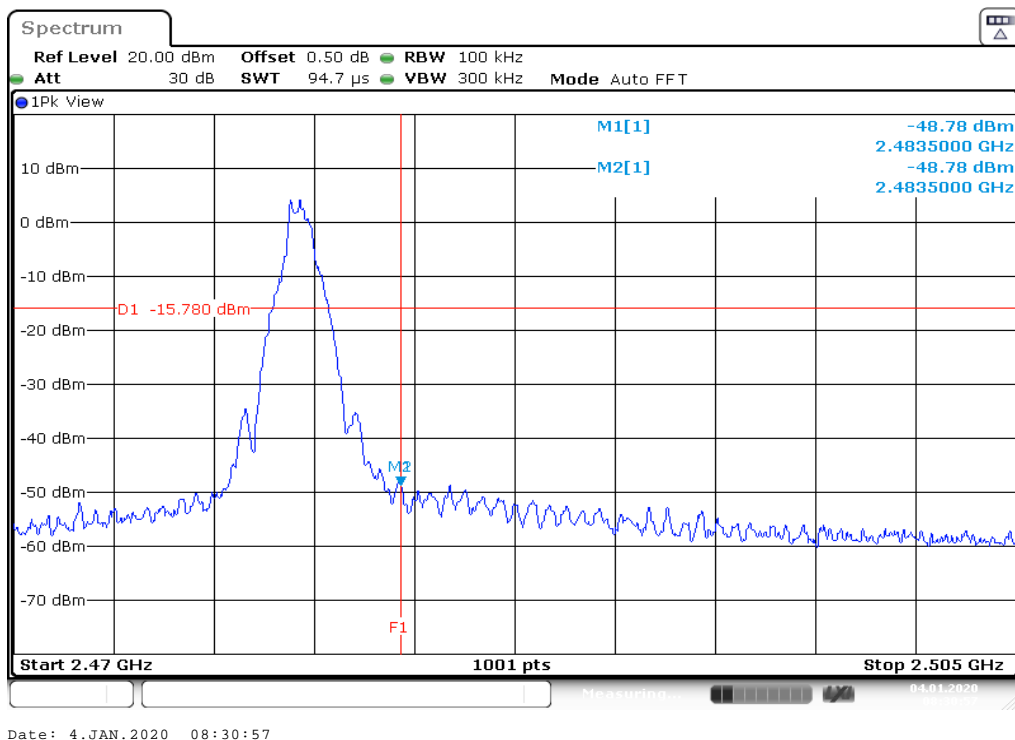

Test Plot 100kHz RBW of Band Edge, IEEE 802.15.4

Low Channel

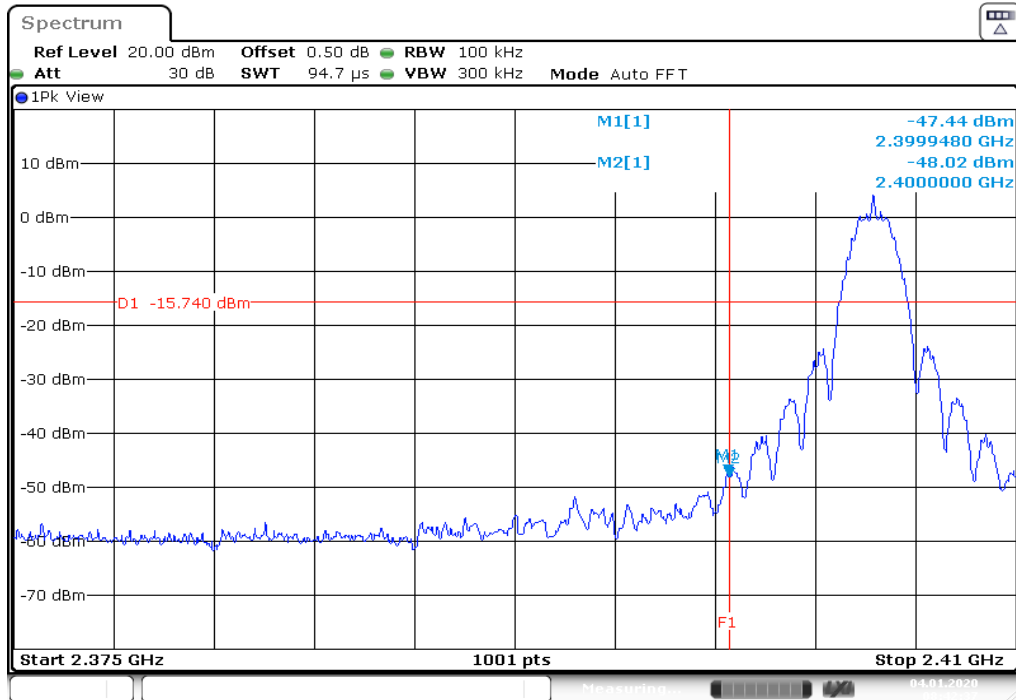

High Channel

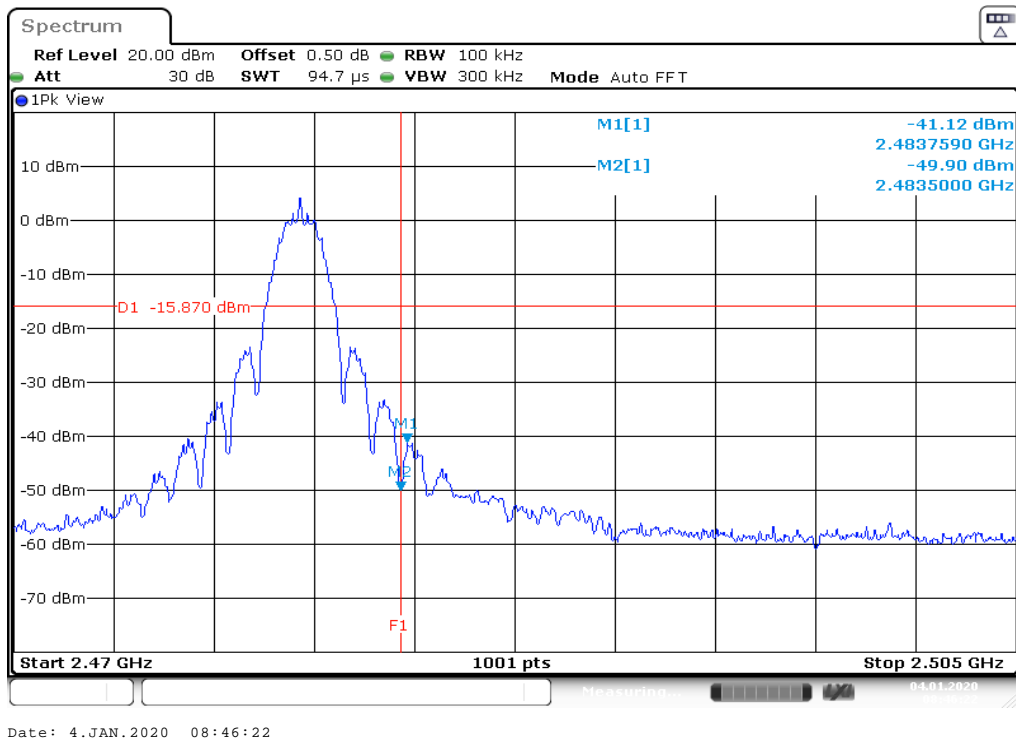

5.1.6 Spurious Emission

RESULT:**Passed**

Test standard	:	FCC part 15.247(d), FCC 15.205, FCC 15.209, ISED RSS-247 5.5 and ISED RSS-Gen issue 5
Basic standard	:	ANSI C63.10: 2013
Limits	:	Radiated emissions which fall in the restricted bands, as defined in FCC 15.205(a) and ISED RSS-Gen i5, 8.10 (Table 7), must comply with the radiated emission limits specified in FCC 15.209(a) and ISED RSS-Gen i5, 8.9 (Table 5 and 6). Emission radiated outside the specified frequency bands must comply with the radiated emission limits specified in FCC 15.209(a) and ISED RSS-Gen i5, 8.9 (Table 5 and 6).
Kind of test site	:	3m Semi-Anechoic Chamber

Test setup

Test Channel	:	Low/ Middle/ High
Operation mode	:	A, B

For details refer to Appendix D.

The Radiated Emissions testing was performed in the X, Y and Z axis orientation. The worst-case Axis orientation is recorded in this test report.

Factor (dB/m)=Antenna Factor(dB/m)+Cable loss (dB)
Level(dBuV/m)=Reading(dBuV)+ Factor(dB/m)

5.2 Mains Emissions

5.2.1 Mains Conducted Emissions

RESULT:**Passed**

Test standard : FCC Part 15.207
FCC Part 15.107
ISED RSS-Gen i5 8.8

Limits : Mains Conducted emissions as defined in
above test standards must comply with the
mains conducted emission limits specified

Kind of test site : Shielded Room

Test setup

Test Channel : Middle
Operation mode : A

Remark: For details refer to Appendix D.

6. Safety Human exposure

6.1 Radio Frequency Exposure Compliance

6.1.1 Electromagnetic Fields

RESULT:**Passed**

Test standard : FCC KDB Publication 447498 D01 v06
47CFR 1.1310
47CFR 2.1091
ISED RSS-102 issue 5

FCC:

Therefore the maximum output power of the transmitter is 2.66mW < 10mW (Distance: 5 mm), hence the EUT is excluded from SAR evaluation according to FCC KDB publication 447498 D01: Mobile Portable RF Exposure.

Canada:

Maximum conducted peak power: 2.66mW
Antenna Gain(Numeric): 0.427
Maximum EIRP available 1.136mW

Since maximum output power of the transmitter is 2.66mW(maximum power)<4mW (distance ≤5mm), hence the EUT is excluded from SAR evaluation according to Table 1 in ISED RSS-102, For limb-worn devices where the 10 gram value applies, the exemption limits for routine evaluation in Table 1 of ISED RSS-102 are multiplied by a factor of 2.5.

---End---

7. Photographs of the Test Set-Up

Photograph 1: Set-up for Spurious Emissions (Front View 1)



Photograph 2: Set-up for Spurious Emissions (Front View 2)



Photograph 3: Set-up for Spurious Emissions (Back View 1)

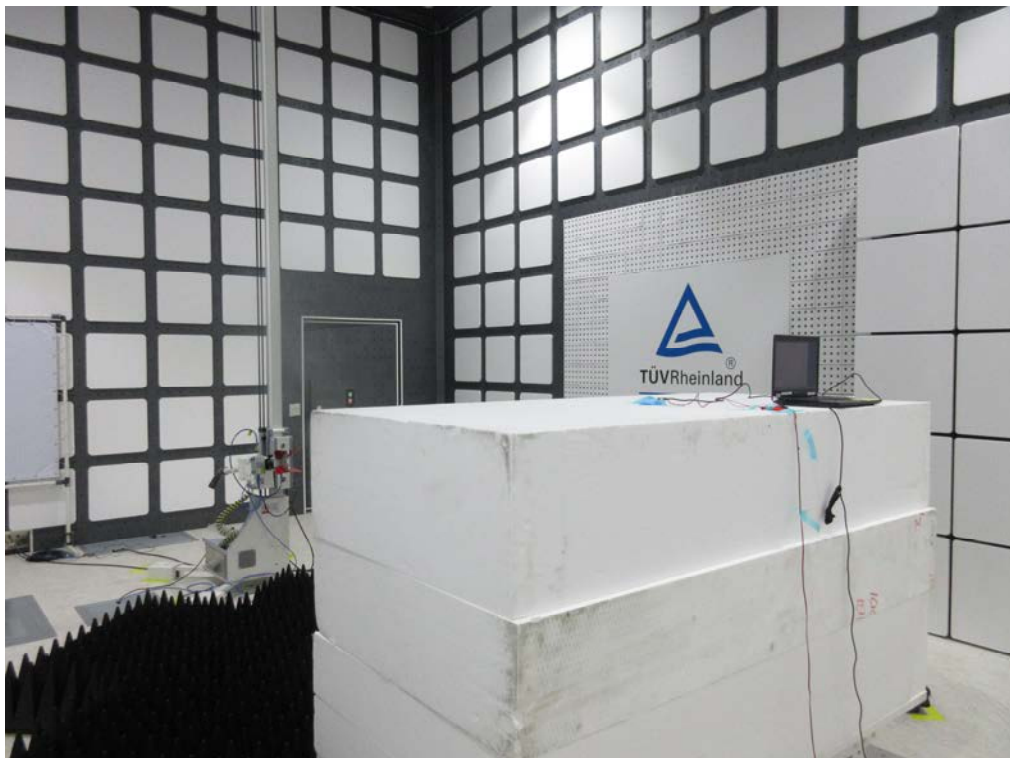

Photograph 4: Set-up for Spurious Emissions (Back View 2)



Photograph 5: Set-up for Spurious Emissions (Back View 3)

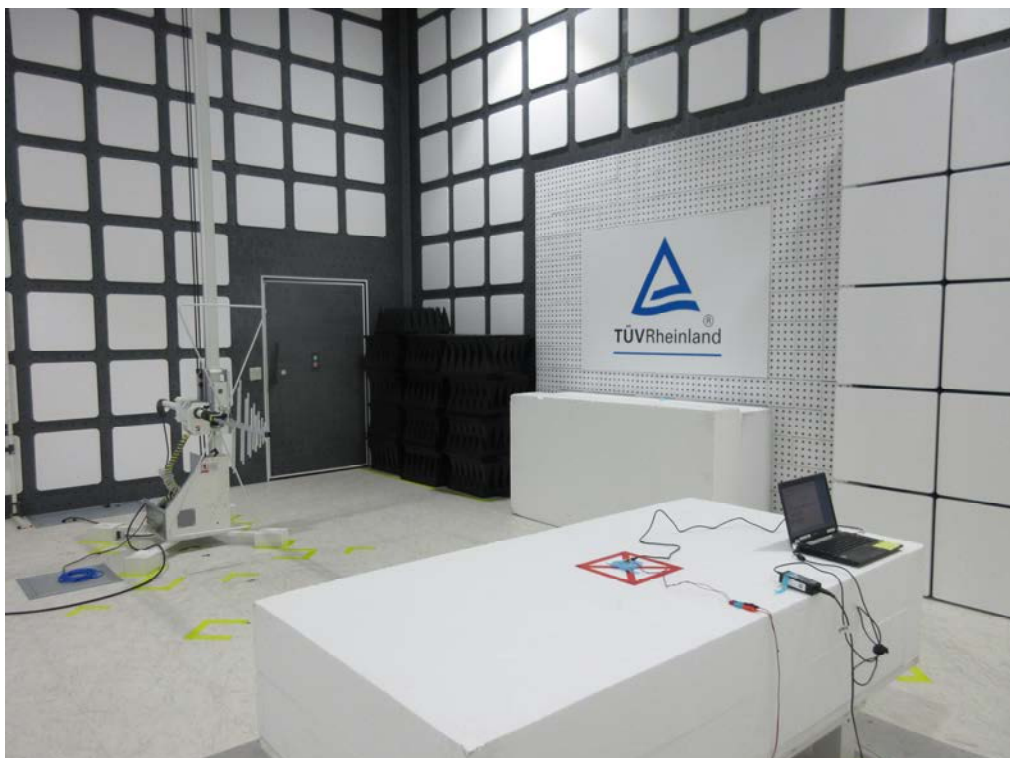

Photograph 6: Set-up for Spurious Emissions (Back View 4)

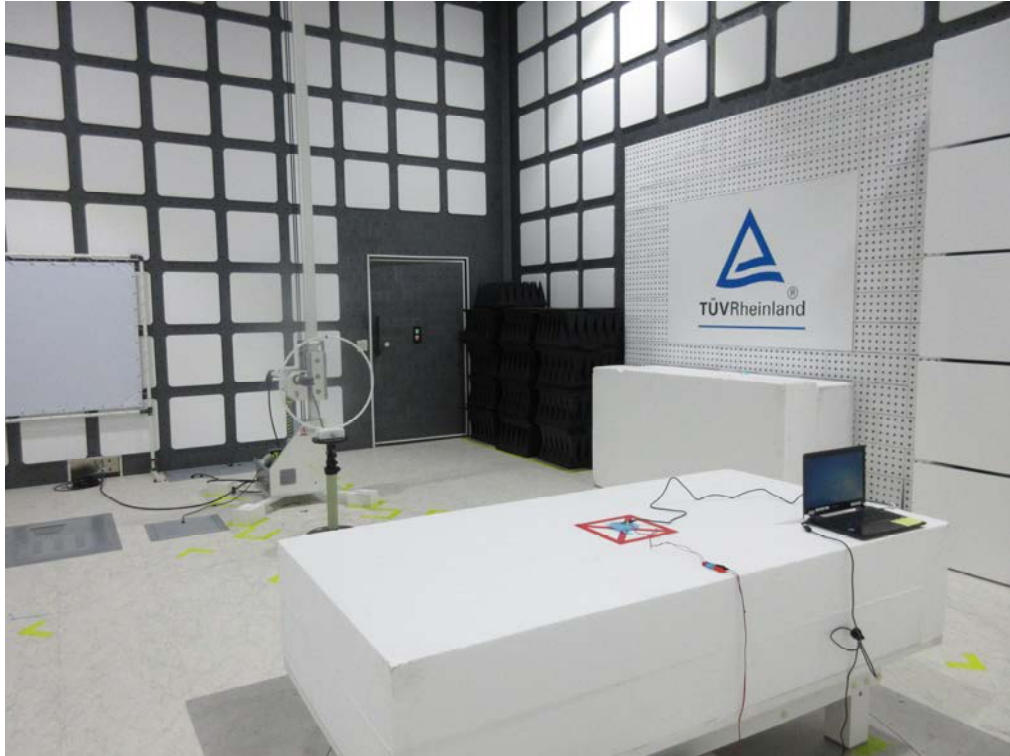

Photograph 7: Set-up for Mains Conducted testing (Front View)



Photograph 8: Set-up for Mains Conducted testing (Back View)



8. List of Tables

Table 1: Applied Standard and Test Levels	5
Table 2: List of Test and Measurement Equipment	7
Table 3: Emission Measurement Uncertainty.....	8
Table 4: Basic Information of EUT	9
Table 5: Technical Specification of EUT	9
Table 6: Test result of Maximum conducted Peak output power, LE 1M.....	16
Table 7: Test result of Maximum conducted Peak output power, LE 2M.....	16
Table 8: Test result of Maximum conducted Peak output power, BLE Long range (125KMbps)	17
Table 9: Test result of Maximum conducted Peak output power, BLE Long range (500KMbps)	17
Table 10: Test result of Maximum conducted Peak output power, ANT 1M.....	17
Table 11: Test result of Maximum conducted Peak output power, Nordic Original 2M.....	17
Table 12: Test result of Maximum conducted Peak output power, IEEE 802.15.4.....	18
Table 13: Test result of 6dB Bandwidth, LE 1M.....	19
Table 14: Test result of 6dB Bandwidth, LE 2M.....	19
Table 15: Test result of 6dB Bandwidth, ANT 1M.....	19
Table 16: Test result of 6dB Bandwidth, Nordic Original 2M	20
Table 17: Test result of 6dB Bandwidth, IEEE 802.15.4	20
Table 18: Test result of 99% Bandwidth, LE 1M.....	20
Table 19: Test result of 99% Bandwidth, LE 2M.....	20
Table 20: Test result of 99% Bandwidth, ANT 1M	20
Table 21: Test result of 99% Bandwidth, Nordic Original 2M.....	20
Table 22: Test result of 99% Bandwidth, IEEE 802.15.4	20
Table 23: Test result of Power Density, LE 1M.....	31
Table 24: Test result of Power Density, LE 2M.....	31
Table 25: Test result of Power Density, ANT 1M.....	31
Table 26: Test result of Power Density, Nordic Original 2M	32
Table 27: Test result of Power Density, IEEE 802.15.4	32

9. List of Photographs

Photograph 1: Set-up for Spurious Emissions (Front View 1).....	58
Photograph 2: Set-up for Spurious Emissions (Front View 2).....	59
Photograph 3: Set-up for Spurious Emissions (Back View 1)	59
Photograph 4: Set-up for Spurious Emissions (Back View 2)	60
Photograph 5: Set-up for Spurious Emissions (Back View 3).....	60
Photograph 6: Set-up for Spurious Emissions (Back View 4).....	61
Photograph 7: Set-up for Mains Conducted testing (Front View).....	62
Photograph 8: Set-up for Mains Conducted testing (Back View).....	62