

Appendix B: SAR System Check Plots

Date: 2021/10/22

Test Laboratory: Underwriters Laboratories Taiwan Co., Ltd

System Validation_Head_2450MHz

DUT: D2450V2-SN:988; Type: D2450V2; Serial: D2450V2-SN:988

Communication System: UID 0, CW (0); Communication System Band: D2450 (2450.0 MHz);

Frequency: 2450 MHz; Communication System PAR: 0 dB; PMF: 1

Medium parameters used: $f = 2450$ MHz; $\sigma = 1.857$ S/m; $\epsilon_r = 37.765$; $\rho = 1000$ kg/m³

Phantom section: Flat Section

Measurement Standard: DASYS5 (IEEE/IEC/ANSI C63.19-2007)

DASY Configuration:

- Probe: EX3DV4 - SN3826; ConvF(7.22, 7.22, 7.22) @ 2450 MHz; Calibrated: 2021/7/28
 - Modulation Compensation:
- Sensor-Surface: 1.4mm (Mechanical Surface Detection), $z = 1.0, 31.0$
- Electronics: DAE3 Sn528; Calibrated: 2021/7/26
- Phantom: ELI v5.0_1213; Type: QDOVA001BB; Serial: 1213
- DASYS5 52.10.4(1527); SEMCAD X 14.6.14(7483)

Configuration/2450MHz/Area Scan (71x71x1): Interpolated grid: $dx=1.200$ mm, $dy=1.200$ mm
Maximum value of SAR (interpolated) = 23.1 W/kg

Configuration/2450MHz/Zoom Scan (7x7x7)/Cube 0: Measurement grid: $dx=5$ mm, $dy=5$ mm, $dz=5$ mm

Reference Value = 106.7 V/m; Power Drift = 0.15 dB

Peak SAR (extrapolated) = 28.1 W/kg

SAR(1 g) = 13.4 W/kg; SAR(10 g) = 6.08 W/kg

Smallest distance from peaks to all points 3 dB below = 8 mm

Ratio of SAR at M2 to SAR at M1 = 48.5%

Maximum value of SAR (measured) = 22.2 W/kg

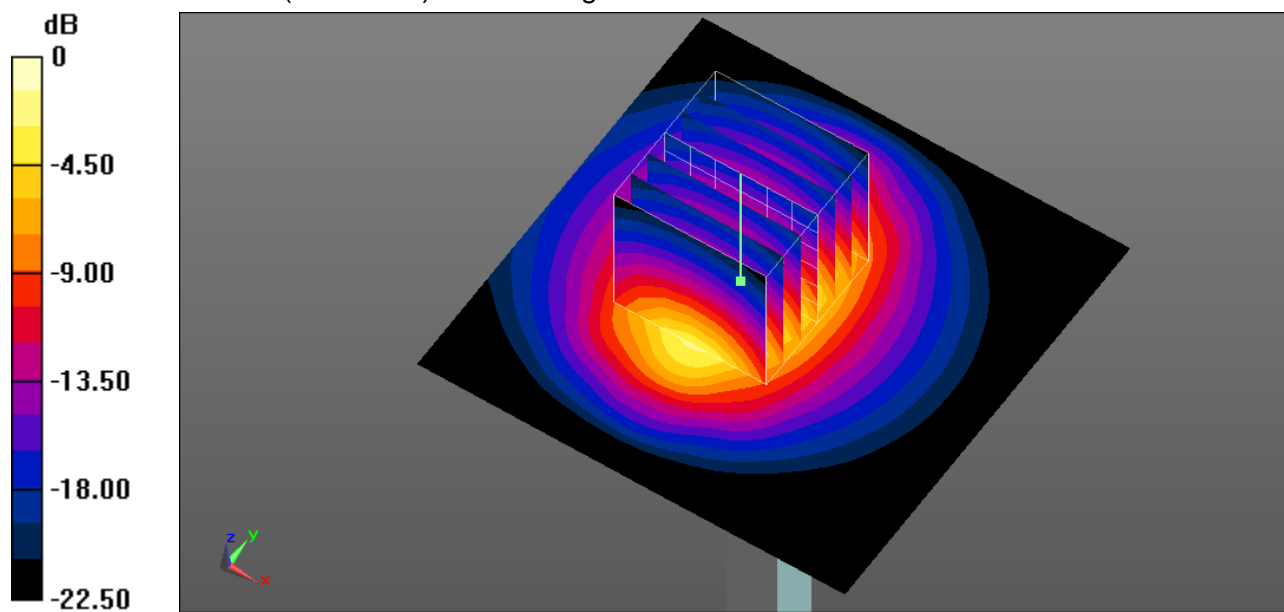

0 dB = 22.2 W/kg = 13.46 dBW/kg

Test Laboratory: Underwriters Laboratories Taiwan Co., Ltd

System Validation_Head_2450MHz

DUT: D2450V2-SN:988; Type: D2450V2; Serial: D2450V2-SN:988

Communication System: UID 0, CW (0); Communication System Band: D2450 (2450.0 MHz);

Frequency: 2450 MHz; Communication System PAR: 0 dB; PMF: 1

Medium parameters used: $f = 2450$ MHz; $\sigma = 1.819$ S/m; $\epsilon_r = 37.624$; $\rho = 1000$ kg/m³

Phantom section: Flat Section

Measurement Standard: DASYS (IEEE/IEC/ANSI C63.19-2007)

DASY Configuration:

- Probe: EX3DV4 - SN3826; ConvF(7.22, 7.22, 7.22) @ 2450 MHz; Calibrated: 2021/7/28
 - Modulation Compensation:
- Sensor-Surface: 1.4mm (Mechanical Surface Detection), $z = 1.0, 31.0$
- Electronics: DAE3 Sn528; Calibrated: 2021/7/26
- Phantom: ELI v5.0_1213; Type: QDOVA001BB; Serial: 1213
- DASYS 52.10.4(1527); SEMCAD X 14.6.14(7483)

Configuration/2450MHz/Area Scan (71x71x1): Interpolated grid: $dx=1.200$ mm, $dy=1.200$ mm

Maximum value of SAR (interpolated) = 24.1 W/kg

Configuration/2450MHz/Zoom Scan (7x7x7)/Cube 0: Measurement grid: $dx=5$ mm, $dy=5$ mm, $dz=5$ mm

Reference Value = 103.2 V/m; Power Drift = 0.19 dB

Peak SAR (extrapolated) = 29.4 W/kg

SAR(1 g) = 14.1 W/kg; SAR(10 g) = 6.51 W/kg

Smallest distance from peaks to all points 3 dB below = 9 mm

Ratio of SAR at M2 to SAR at M1 = 48.1%

Maximum value of SAR (measured) = 23.7 W/kg

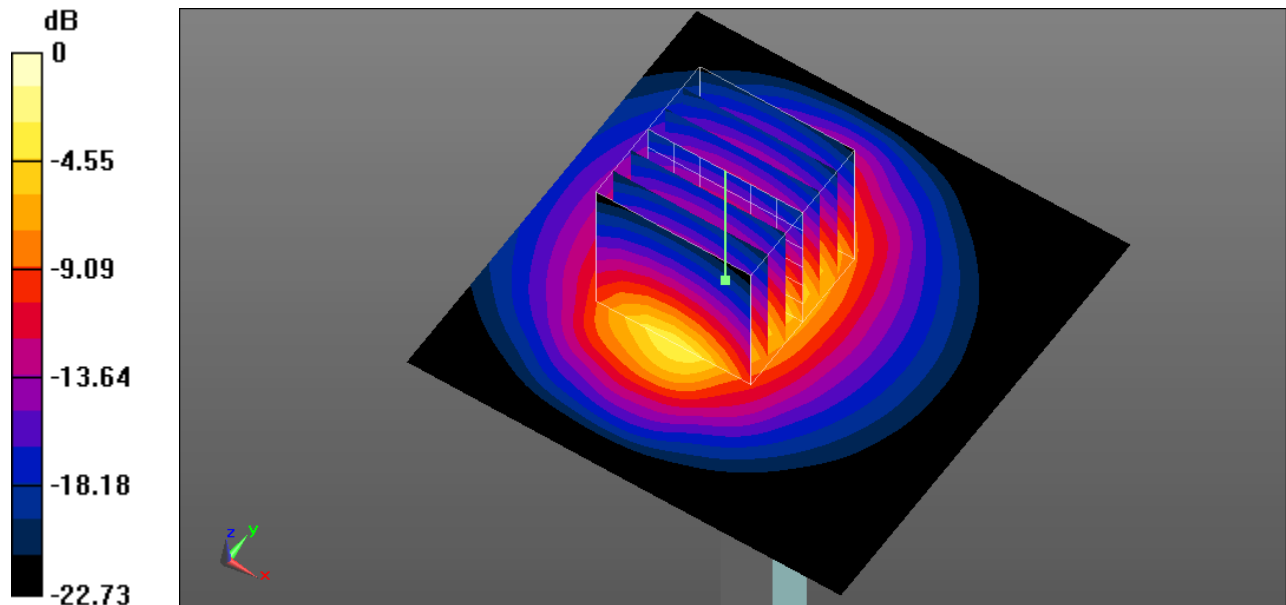

0 dB = 23.7 W/kg = 13.75 dBW/kg

Date: 2021/10/16

Test Laboratory: Underwriters Laboratories Taiwan Co., Ltd

System Validation_Head_5250MHz**DUT: D5GHzV2 - SN1244; Type: D5GHzV2; Serial: SN1244**

Communication System: UID 0, CW (0); Communication System Band: D5GHz (5000.0 - 6000.0 MHz);

Frequency: 5250 MHz; Communication System PAR: 0 dB; PMF: 1

Medium parameters used: $f = 5250$ MHz; $\sigma = 4.623$ S/m; $\epsilon_r = 34.788$; $\rho = 1000$ kg/m³

Phantom section: Flat Section

Measurement Standard: DASYS (IEEE/IEC/ANSI C63.19-2007)

DASY Configuration:

- Probe: EX3DV4 - SN3826; ConvF(5.06, 5.06, 5.06) @ 5250 MHz; Calibrated: 2021/7/28
 - Modulation Compensation:
- Sensor-Surface: 1.4mm (Mechanical Surface Detection), $z = 1.0, 22.0$
- Electronics: DAE3 Sn528; Calibrated: 2021/7/26
- Phantom: ELI v5.0_1213; Type: QDOVA001BB; Serial: 1213
- DASYS 52.10.4(1527); SEMCAD X 14.6.14(7483)

Configuration/5250MHz/Area Scan (91x91x1): Interpolated grid: $dx=1.000$ mm, $dy=1.000$ mm

Maximum value of SAR (interpolated) = 19.8 W/kg

Configuration/5250MHz/Zoom Scan (7x7x7)/Cube 0: Measurement grid: $dx=4$ mm, $dy=4$ mm, $dz=1.4$ mm

Reference Value = 65.50 V/m; Power Drift = -0.15 dB

Peak SAR (extrapolated) = 32.0 W/kg

SAR(1 g) = 7.76 W/kg; SAR(10 g) = 2.15 W/kg

Smallest distance from peaks to all points 3 dB below = 7.4 mm

Ratio of SAR at M2 to SAR at M1 = 64.6%

Maximum value of SAR (measured) = 19.2 W/kg

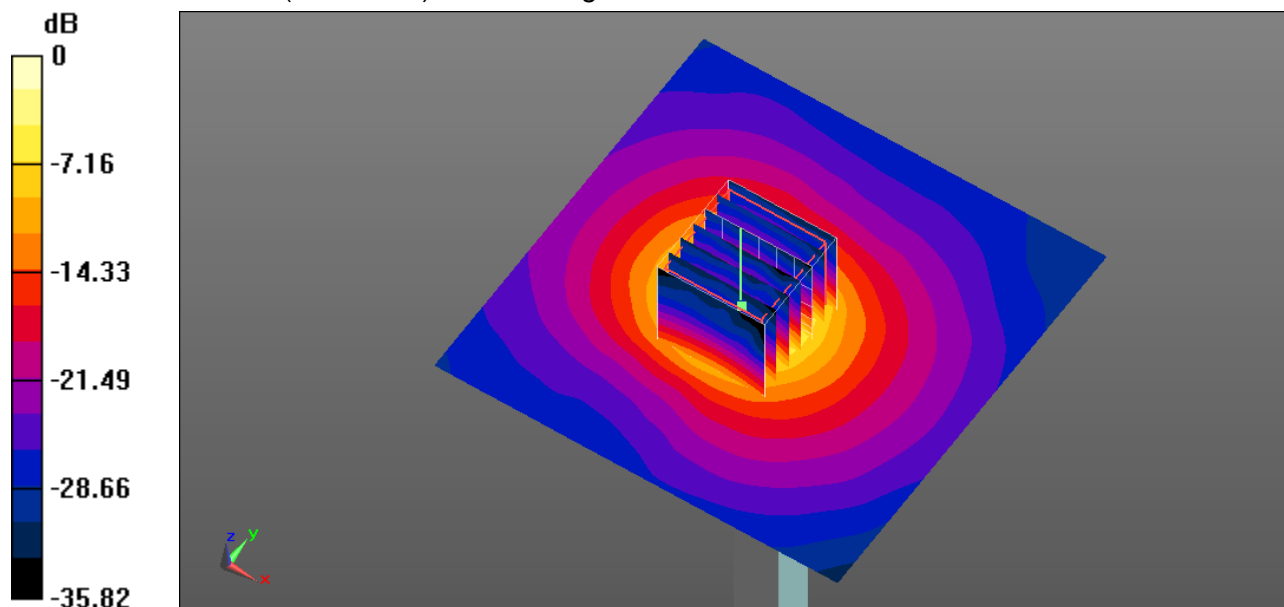

0 dB = 19.2 W/kg = 12.83 dBW/kg

Date: 2021/10/18

Test Laboratory: Underwriters Laboratories Taiwan Co., Ltd

System Validation_Head_5250MHz_1018**DUT: D5GHzV2 - SN1244; Type: D5GHzV2; Serial: SN1244**

Communication System: UID 0, CW (0); Communication System Band: D5GHz (5000.0 - 6000.0 MHz);

Frequency: 5250 MHz; Communication System PAR: 0 dB; PMF: 1

Medium parameters used: $f = 5250$ MHz; $\sigma = 4.855$ S/m; $\epsilon_r = 35.857$; $\rho = 1000$ kg/m³

Phantom section: Flat Section

Measurement Standard: DASYS (IEEE/IEC/ANSI C63.19-2007)

DASY Configuration:

- Probe: EX3DV4 - SN3826; ConvF(5.06, 5.06, 5.06) @ 5250 MHz; Calibrated: 2021/7/28
 - Modulation Compensation:
- Sensor-Surface: 1.4mm (Mechanical Surface Detection), $z = 1.0, 22.0$
- Electronics: DAE3 Sn528; Calibrated: 2021/7/26
- Phantom: ELI v5.0_1213; Type: QDOVA001BB; Serial: 1213
- DASYS 52.10.4(1527); SEMCAD X 14.6.14(7483)

Configuration/5250MHz/Area Scan (91x91x1): Interpolated grid: $dx=1.000$ mm, $dy=1.000$ mm

Maximum value of SAR (interpolated) = 19.2 W/kg

Configuration/5250MHz/Zoom Scan (7x7x7)/Cube 0: Measurement grid: $dx=4$ mm, $dy=4$ mm, $dz=1.4$ mm

Reference Value = 65.89 V/m; Power Drift = -0.10 dB

Peak SAR (extrapolated) = 31.8 W/kg

SAR(1 g) = 7.54 W/kg; SAR(10 g) = 2.09 W/kg

Smallest distance from peaks to all points 3 dB below = 7.5 mm

Ratio of SAR at M2 to SAR at M1 = 63.5%

Maximum value of SAR (measured) = 18.8 W/kg

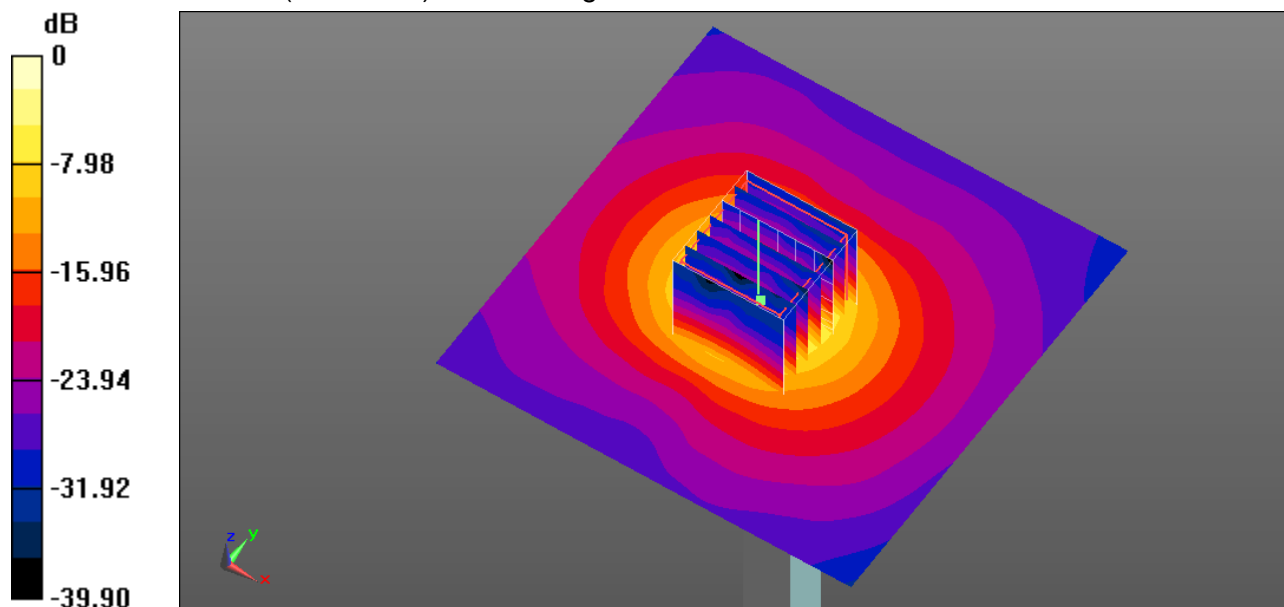

0 dB = 18.8 W/kg = 12.74 dBW/kg

Date: 2021/10/19

Test Laboratory: Underwriters Laboratories Taiwan Co., Ltd

System Validation_Head_5600MHz**DUT: D5GHzV2 - SN1244; Type: D5GHzV2; Serial: SN1244**

Communication System: UID 0, CW (0); Communication System Band: D5GHz (5000.0 - 6000.0 MHz);

Frequency: 5600 MHz; Communication System PAR: 0 dB; PMF: 1

Medium parameters used: $f = 5600$ MHz; $\sigma = 5.26$ S/m; $\epsilon_r = 34.033$; $\rho = 1000$ kg/m³

Phantom section: Flat Section

Measurement Standard: DASYS (IEEE/IEC/ANSI C63.19-2007)

DASY Configuration:

- Probe: EX3DV4 - SN3826; ConvF(4.68, 4.68, 4.68) @ 5600 MHz; Calibrated: 2021/7/28
 - Modulation Compensation:
- Sensor-Surface: 1.4mm (Mechanical Surface Detection), $z = 1.0, 22.0$
- Electronics: DAE3 Sn528; Calibrated: 2021/7/26
- Phantom: ELI v5.0_1213; Type: QDOVA001BB; Serial: 1213
- DASYS 52.10.4(1527); SEMCAD X 14.6.14(7483)

Configuration/5600MHz/Area Scan (91x91x1): Interpolated grid: $dx=1.000$ mm, $dy=1.000$ mm

Maximum value of SAR (interpolated) = 21.4 W/kg

Configuration/5600MHz/Zoom Scan (7x7x7)/Cube 0: Measurement grid: $dx=4$ mm, $dy=4$ mm, $dz=1.4$ mm

Reference Value = 63.85 V/m; Power Drift = 0.19 dB

Peak SAR (extrapolated) = 36.8 W/kg

SAR(1 g) = 8.65 W/kg; SAR(10 g) = 2.36 W/kg

Smallest distance from peaks to all points 3 dB below = 7.4 mm

Ratio of SAR at M2 to SAR at M1 = 63.1%

Maximum value of SAR (measured) = 22.3 W/kg

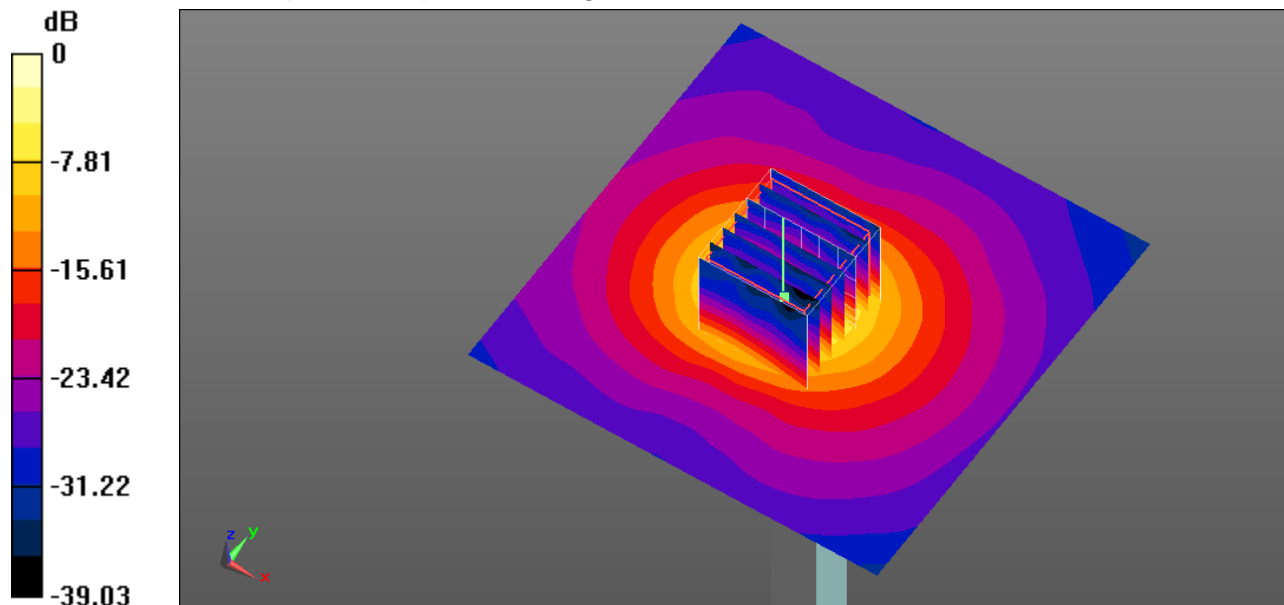

0 dB = 22.3 W/kg = 13.48 dBW/kg

Date: 2021/10/21

Test Laboratory: Underwriters Laboratories Taiwan Co., Ltd

System Validation_Head_5600MHz**DUT: D5GHzV2 - SN1244; Type: D5GHzV2; Serial: SN1244**

Communication System: UID 0, CW (0); Communication System Band: D5GHz (5000.0 - 6000.0 MHz);

Frequency: 5600 MHz; Communication System PAR: 0 dB; PMF: 1

Medium parameters used: $f = 5600$ MHz; $\sigma = 4.898$ S/m; $\epsilon_r = 34.384$; $\rho = 1000$ kg/m³

Phantom section: Flat Section

Measurement Standard: DASYS (IEEE/IEC/ANSI C63.19-2007)

DASY Configuration:

- Probe: EX3DV4 - SN3826; ConvF(4.68, 4.68, 4.68) @ 5600 MHz; Calibrated: 2021/7/28
 - Modulation Compensation:
- Sensor-Surface: 1.4mm (Mechanical Surface Detection), $z = 1.0, 22.0$
- Electronics: DAE3 Sn528; Calibrated: 2021/7/26
- Phantom: ELI v5.0_1213; Type: QDOVA001BB; Serial: 1213
- DASYS 52.10.4(1527); SEMCAD X 14.6.14(7483)

Configuration/5600MHz/Area Scan (91x91x1): Interpolated grid: $dx=1.000$ mm, $dy=1.000$ mm

Maximum value of SAR (interpolated) = 17.6 W/kg

Configuration/5600MHz/Zoom Scan (7x7x7)/Cube 0: Measurement grid: $dx=4$ mm, $dy=4$ mm, $dz=1.4$ mm

Reference Value = 65.19 V/m; Power Drift = 0.15 dB

Peak SAR (extrapolated) = 32.3 W/kg

SAR(1 g) = 7.81 W/kg; SAR(10 g) = 2.19 W/kg

Smallest distance from peaks to all points 3 dB below = 7.4 mm

Ratio of SAR at M2 to SAR at M1 = 64.5%

Maximum value of SAR (measured) = 18.9 W/kg

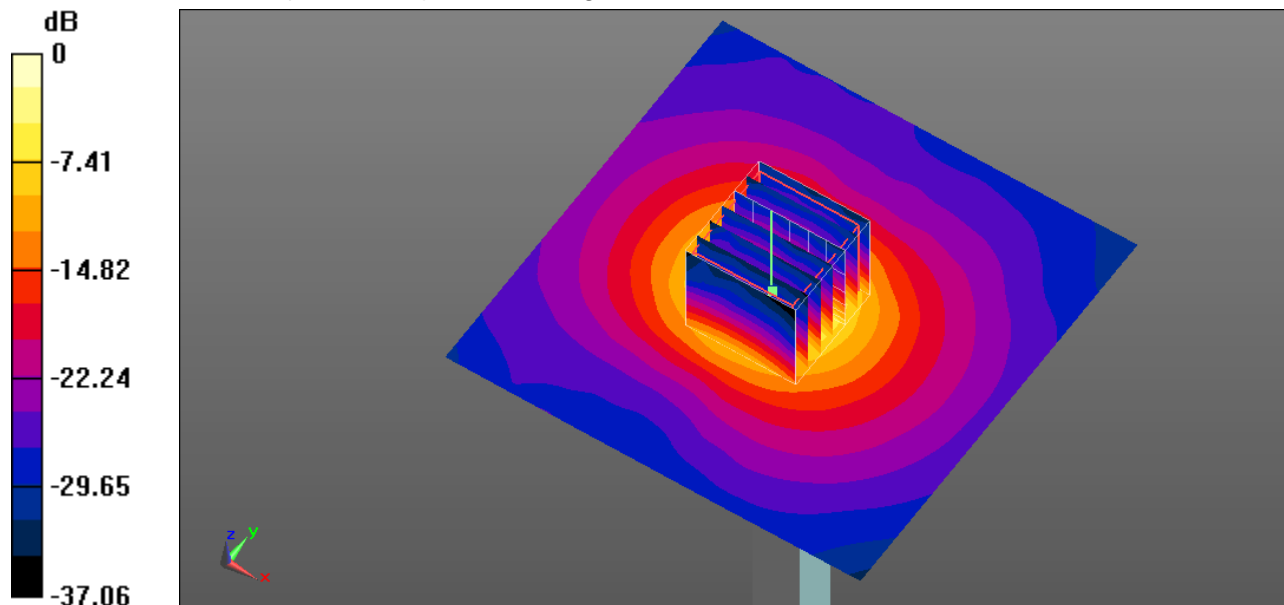

0 dB = 18.9 W/kg = 12.76 dBW/kg

Test Laboratory: Underwriters Laboratories Taiwan Co., Ltd

System Validation_Head_5800MHz

DUT: D5GHzV2 - SN1244; Type: D5GHzV2; Serial: SN1244

Communication System: UID 0, CW (0); Communication System Band: D5GHz (5000.0 - 6000.0 MHz);

Frequency: 5800 MHz; Communication System PAR: 0 dB; PMF: 1

Medium parameters used: $f = 5800 \text{ MHz}$; $\sigma = 5.162 \text{ S/m}$; $\epsilon_r = 33.776$; $\rho = 1000 \text{ kg/m}^3$

Phantom section: Flat Section

Measurement Standard: DASYS (IEEE/IEC/ANSI C63.19-2007)

DASY Configuration:

- Probe: EX3DV4 - SN3826; ConvF(4.74, 4.74, 4.74) @ 5800 MHz; Calibrated: 2021/7/28
 - Modulation Compensation:
- Sensor-Surface: 1.4mm (Mechanical Surface Detection), $z = 1.0, 22.0$
- Electronics: DAE3 Sn528; Calibrated: 2021/7/26
- Phantom: ELI v5.0_1213; Type: QDOVA001BB; Serial: 1213
- DASYS 52.10.4(1527); SEMCAD X 14.6.14(7483)

Configuration/5800MHz/Area Scan (91x91x1): Interpolated grid: $dx=1.000 \text{ mm}$, $dy=1.000 \text{ mm}$

Maximum value of SAR (interpolated) = 19.2 W/kg

Configuration/5800MHz/Zoom Scan (7x7x7)/Cube 0: Measurement grid: $dx=4\text{mm}$, $dy=4\text{mm}$, $dz=1.4\text{mm}$

Reference Value = 56.87 V/m; Power Drift = 0.14 dB

Peak SAR (extrapolated) = 31.2 W/kg

SAR(1 g) = 7.75 W/kg; SAR(10 g) = 2.15 W/kg

Smallest distance from peaks to all points 3 dB below = 7.4 mm

Ratio of SAR at M2 to SAR at M1 = 65.1%

Maximum value of SAR (measured) = 19.0 W/kg

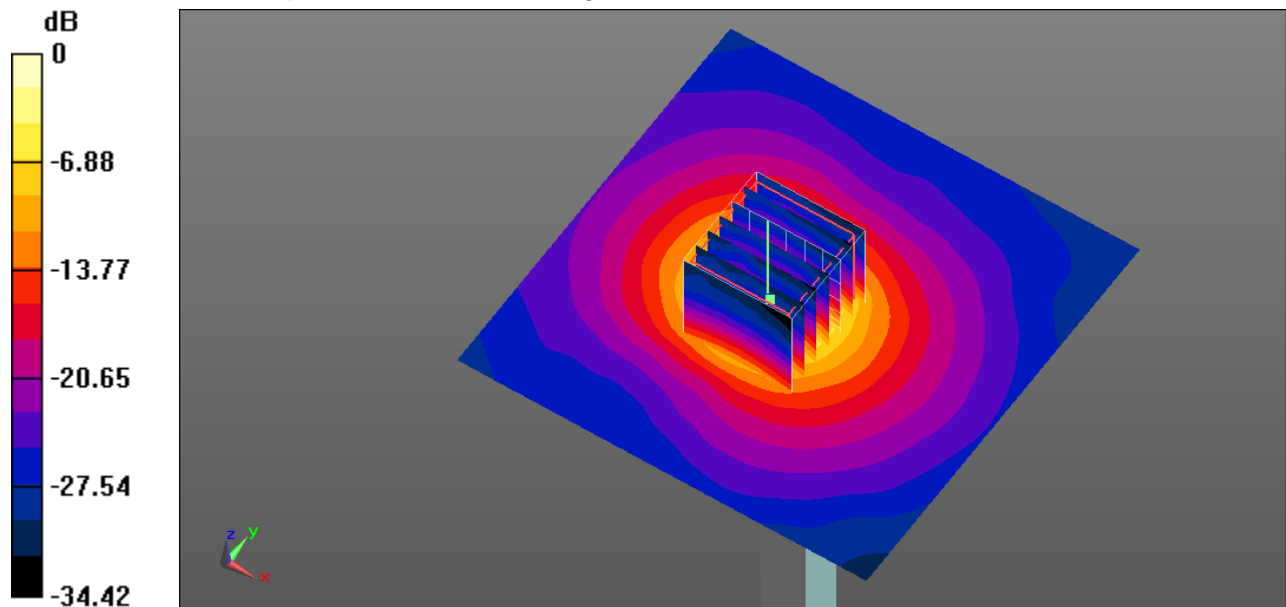

0 dB = 19.0 W/kg = 12.79 dBW/kg

Test Laboratory: Underwriters Laboratories Taiwan Co., Ltd

System Validation_Head_5800MHz

DUT: D5GHzV2 - SN1244; Type: D5GHzV2; Serial: SN1244

Communication System: UID 0, CW (0); Communication System Band: D5GHz (5000.0 - 6000.0 MHz);

Frequency: 5800 MHz; Communication System PAR: 0 dB; PMF: 1

Medium parameters used: $f = 5800$ MHz; $\sigma = 5.148$ S/m; $\epsilon_r = 34.095$; $\rho = 1000$ kg/m³

Phantom section: Flat Section

Measurement Standard: DASYS (IEEE/IEC/ANSI C63.19-2007)

DASY Configuration:

- Probe: EX3DV4 - SN3826; ConvF(4.74, 4.74, 4.74) @ 5800 MHz; Calibrated: 2021/7/28
 - Modulation Compensation:
- Sensor-Surface: 1.4mm (Mechanical Surface Detection), $z = 1.0, 22.0$
- Electronics: DAE3 Sn528; Calibrated: 2021/7/26
- Phantom: ELI v5.0_1213; Type: QDOVA001BB; Serial: 1213
- DASYS 52.10.4(1527); SEMCAD X 14.6.14(7483)

Configuration/5800MHz/Area Scan (91x91x1): Interpolated grid: $dx=1.000$ mm, $dy=1.000$ mm

Maximum value of SAR (interpolated) = 20.2 W/kg

Configuration/5800MHz/Zoom Scan (7x7x7)/Cube 0: Measurement grid: $dx=4$ mm, $dy=4$ mm, $dz=1.4$ mm

Reference Value = 65.38 V/m; Power Drift = 0.15 dB

Peak SAR (extrapolated) = 33.4 W/kg

SAR(1 g) = 8.18 W/kg; SAR(10 g) = 2.29 W/kg

Smallest distance from peaks to all points 3 dB below = 7.4 mm

Ratio of SAR at M2 to SAR at M1 = 64.6%

Maximum value of SAR (measured) = 19.7 W/kg

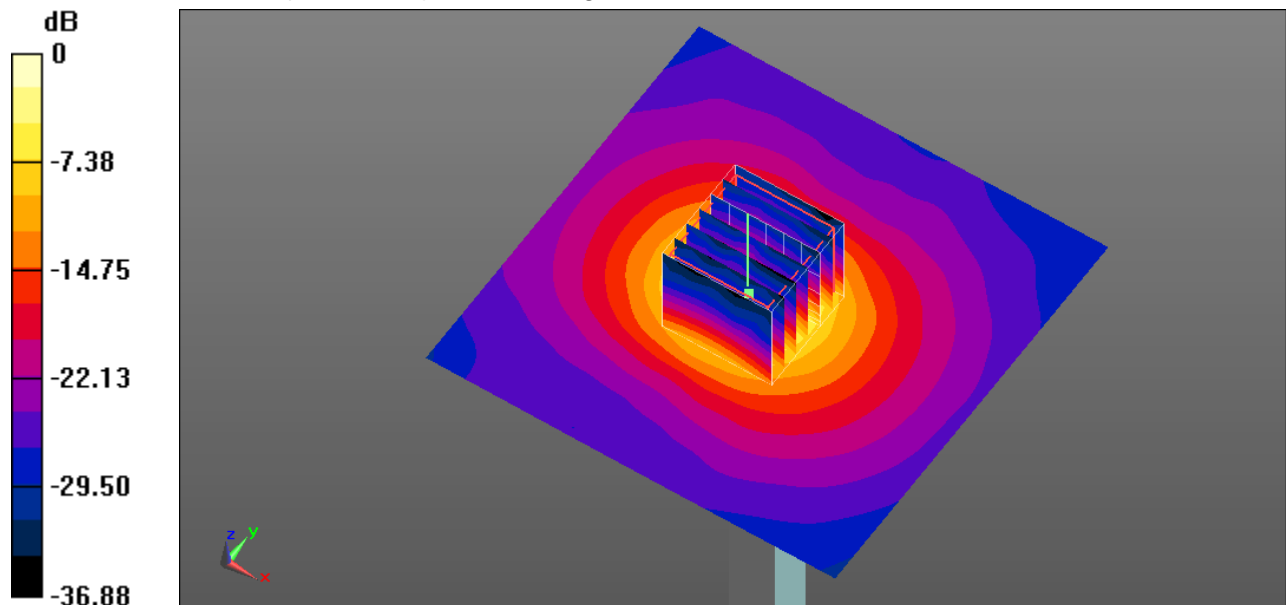

0 dB = 19.7 W/kg = 12.94 dBW/kg

Appendix C: Highest SAR Test Plots

Date: 2021/10/22

Test Laboratory: Underwriters Laboratories Taiwan Co., Ltd

Wi-Fi 2.4 GHz_Horizontal-Down_Chain 0

Communication System: UID 0, 802.11b/g/n (0); Communication System Band: 802.11b/g/n; Frequency: 2437 MHz; Communication System PAR: 0 dB; PMF: 1

Medium parameters used: $f = 2437$ MHz; $\sigma = 1.845$ S/m; $\epsilon_r = 37.804$; $\rho = 1000$ kg/m³

Phantom section: Flat Section

Measurement Standard: DASYS5 (IEEE/IEC/ANSI C63.19-2011)

DASY Configuration:

- Probe: EX3DV4 - SN3826; ConvF(7.22, 7.22, 7.22) @ 2437 MHz; Calibrated: 2021/7/28
 - Modulation Compensation:
- Sensor-Surface: 1.4mm (Mechanical Surface Detection), $z = -49.0, 31.0$
- Electronics: DAE3 Sn528; Calibrated: 2021/7/26
- Phantom: ELI v5.0_1213; Type: QDOVA001BB; Serial: 1213
- DASYS5 52.10.4(1527); SEMCAD X 14.6.14(7483)

802.11b/Area Scan (51x71x1): Interpolated grid: $dx=1.200$ mm, $dy=1.200$ mm

Maximum value of SAR (interpolated) = 1.14 W/kg

802.11b/Zoom Scan (7x7x7)/Cube 0: Measurement grid: $dx=5$ mm, $dy=5$ mm, $dz=5$ mm

Reference Value = 24.81 V/m; Power Drift = -0.09 dB

Peak SAR (extrapolated) = 1.30 W/kg

SAR(1 g) = 0.613 W/kg; SAR(10 g) = 0.284 W/kg

Smallest distance from peaks to all points 3 dB below = 10.3 mm

Ratio of SAR at M2 to SAR at M1 = 47.9%

Maximum value of SAR (measured) = 1.02 W/kg

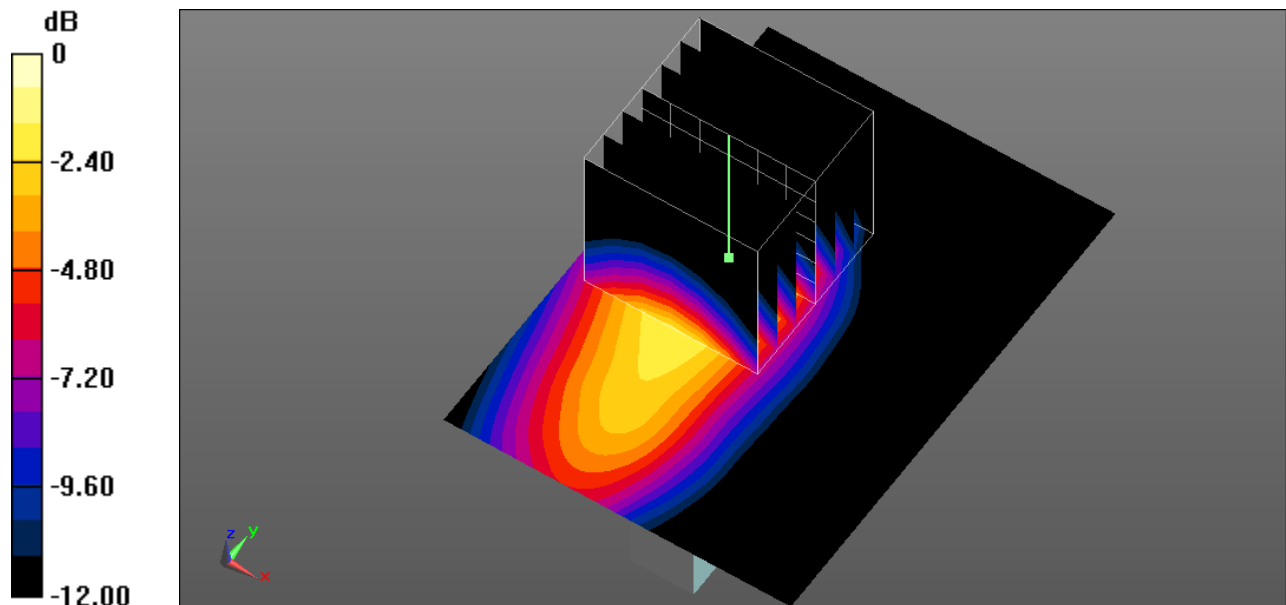

0 dB = 1.02 W/kg = 0.09 dBW/kg

Date: 2021/10/22

Test Laboratory: Underwriters Laboratories Taiwan Co., Ltd

Wi-Fi 2.4 GHz_Horizontal-Down_Chain 1

Communication System: UID 0, 802.11b/g/n (0); Communication System Band: 802.11b/g/n; Frequency: 2437 MHz; Communication System PAR: 0 dB; PMF: 1

Medium parameters used: $f = 2437$ MHz; $\sigma = 1.845$ S/m; $\epsilon_r = 37.804$; $\rho = 1000$ kg/m³

Phantom section: Flat Section

Measurement Standard: DASYS5 (IEEE/IEC/ANSI C63.19-2011)

DASY Configuration:

- Probe: EX3DV4 - SN3826; ConvF(7.22, 7.22, 7.22) @ 2437 MHz; Calibrated: 2021/7/28
 - Modulation Compensation:
- Sensor-Surface: 1.4mm (Mechanical Surface Detection), $z = -49.0, 31.0$
- Electronics: DAE3 Sn528; Calibrated: 2021/7/26
- Phantom: ELI v5.0_1213; Type: QDOVA001BB; Serial: 1213
- DASYS5 52.10.4(1527); SEMCAD X 14.6.14(7483)

802.11b/Area Scan (51x71x1): Interpolated grid: $dx=1.200$ mm, $dy=1.200$ mm
Maximum value of SAR (interpolated) = 0.781 W/kg

802.11b/Zoom Scan (7x7x7)/Cube 0: Measurement grid: $dx=5$ mm, $dy=5$ mm, $dz=5$ mm

Reference Value = 20.19 V/m; Power Drift = 0.01 dB

Peak SAR (extrapolated) = 0.948 W/kg

SAR(1 g) = 0.436 W/kg; SAR(10 g) = 0.200 W/kg

Smallest distance from peaks to all points 3 dB below = 10.4 mm

Ratio of SAR at M2 to SAR at M1 = 46.1%

Maximum value of SAR (measured) = 0.724 W/kg

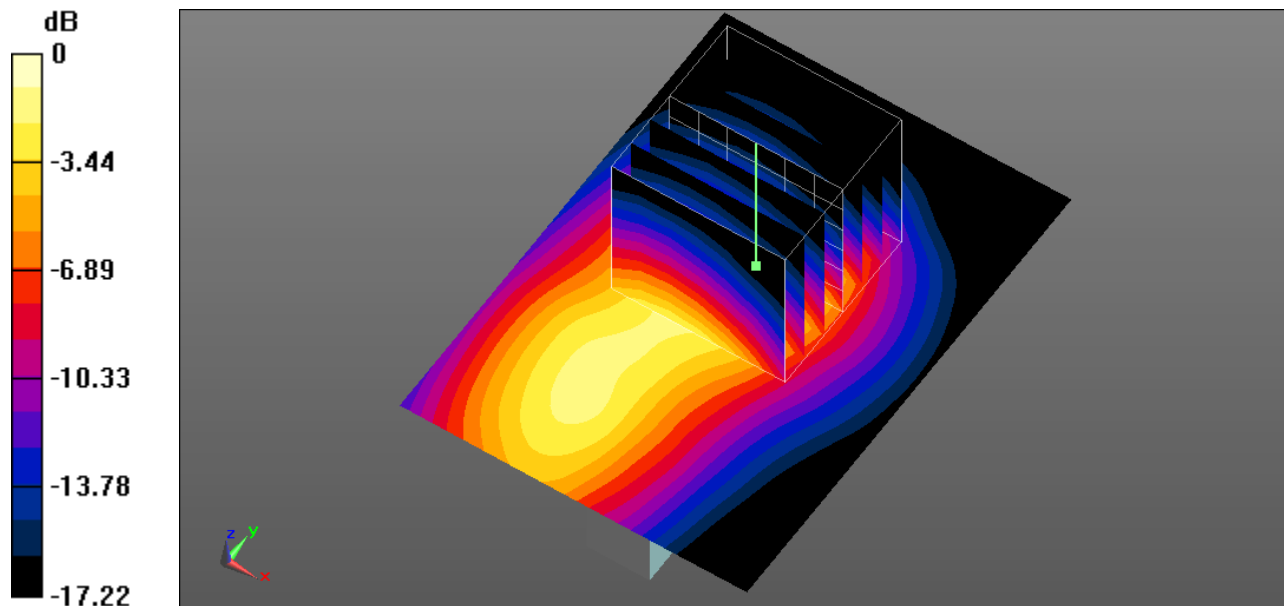

0 dB = 0.724 W/kg = -1.40 dBW/kg

Date: 2021/10/18

Test Laboratory: Underwriters Laboratories Taiwan Co., Ltd

Wi-Fi 5 GHz U-NII 2A_Vertical-Front_Chain 0

Communication System: UID 0, 802.11a/ac 5GHz (0) (0); Communication System Band: 802.11a/ac;
 Frequency: 5280 MHz; Communication System PAR: 0 dB; PMF: 1

Medium parameters used: $f = 5280$ MHz; $\sigma = 4.87$ S/m; $\epsilon_r = 35.838$; $\rho = 1000$ kg/m³

Phantom section: Flat Section

Measurement Standard: DASYS5 (IEEE/IEC/ANSI C63.19-2011)

DASY Configuration:

- Probe: EX3DV4 - SN3826; ConvF(5.06, 5.06, 5.06) @ 5280 MHz; Calibrated: 2021/7/28
 - Modulation Compensation:
- Sensor-Surface: 1.4mm (Mechanical Surface Detection), $z = -49.0, 22.0$
- Electronics: DAE3 Sn528; Calibrated: 2021/7/26
- Phantom: ELI v5.0_1213; Type: QDOVA001BB; Serial: 1213
- DASYS52 52.10.4(1527); SEMCAD X 14.6.14(7483)

802.11n20/Area Scan (61x91x1): Interpolated grid: $dx=1.000$ mm, $dy=1.000$ mm
 Maximum value of SAR (interpolated) = 1.89 W/kg

802.11n20/Zoom Scan (7x7x7)/Cube 0: Measurement grid: $dx=4$ mm, $dy=4$ mm, $dz=1.4$ mm
 Reference Value = 18.40 V/m; Power Drift = 0.07 dB

Peak SAR (extrapolated) = 3.67 W/kg

SAR(1 g) = 0.876 W/kg; SAR(10 g) = 0.273 W/kg

Smallest distance from peaks to all points 3 dB below = 8 mm

Ratio of SAR at M2 to SAR at M1 = 62%

Maximum value of SAR (measured) = 2.13 W/kg

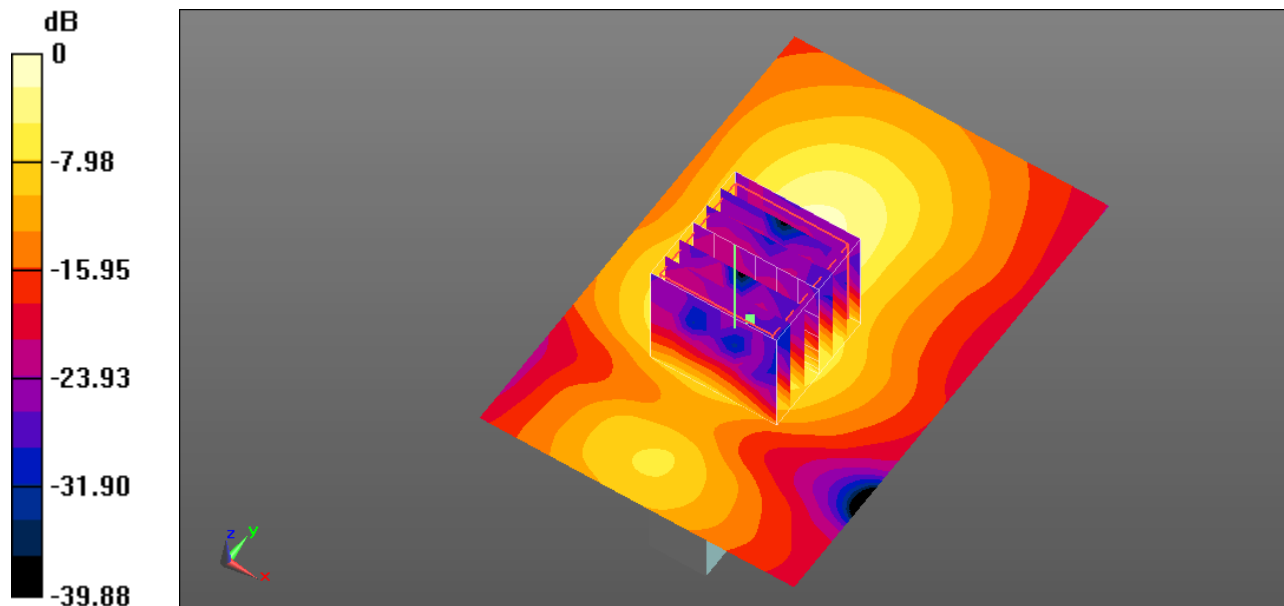

0 dB = 2.13 W/kg = 3.28 dBW/kg

Test Laboratory: Underwriters Laboratories Taiwan Co., Ltd

Wi-Fi 5 GHz U-NII 2A_Vertical-Back_Chain 1

Communication System: UID 0, 802.11a/ac 5GHz (0) (0); Communication System Band: 802.11a/ac;

Frequency: 5270 MHz; Communication System PAR: 0 dB; PMF: 1

Medium parameters used: $f = 5270$ MHz; $\sigma = 4.859$ S/m; $\epsilon_r = 35.828$; $\rho = 1000$ kg/m³

Phantom section: Flat Section

Measurement Standard: DASYS (IEEE/IEC/ANSI C63.19-2011)

DASY Configuration:

- Probe: EX3DV4 - SN3826; ConvF(5.06, 5.06, 5.06) @ 5270 MHz; Calibrated: 2021/7/28
 - Modulation Compensation:
- Sensor-Surface: 1.4mm (Mechanical Surface Detection), $z = -49.0, 22.0$
- Electronics: DAE3 Sn528; Calibrated: 2021/7/26
- Phantom: ELI v5.0_1213; Type: QDOVA001BB; Serial: 1213
- DASYS 52.10.4(1527); SEMCAD X 14.6.14(7483)

802.11ac40/Area Scan (61x91x1): Interpolated grid: $dx=1.000$ mm, $dy=1.000$ mm

Maximum value of SAR (interpolated) = 0.979 W/kg

802.11ac40/Zoom Scan (7x7x7)/Cube 0: Measurement grid: $dx=4$ mm, $dy=4$ mm, $dz=1.4$ mm

Reference Value = 14.43 V/m; Power Drift = -0.15 dB

Peak SAR (extrapolated) = 1.85 W/kg

SAR(1 g) = 0.413 W/kg; SAR(10 g) = 0.134 W/kg

Smallest distance from peaks to all points 3 dB below = 7.9 mm

Ratio of SAR at M2 to SAR at M1 = 60%

Maximum value of SAR (measured) = 1.02 W/kg

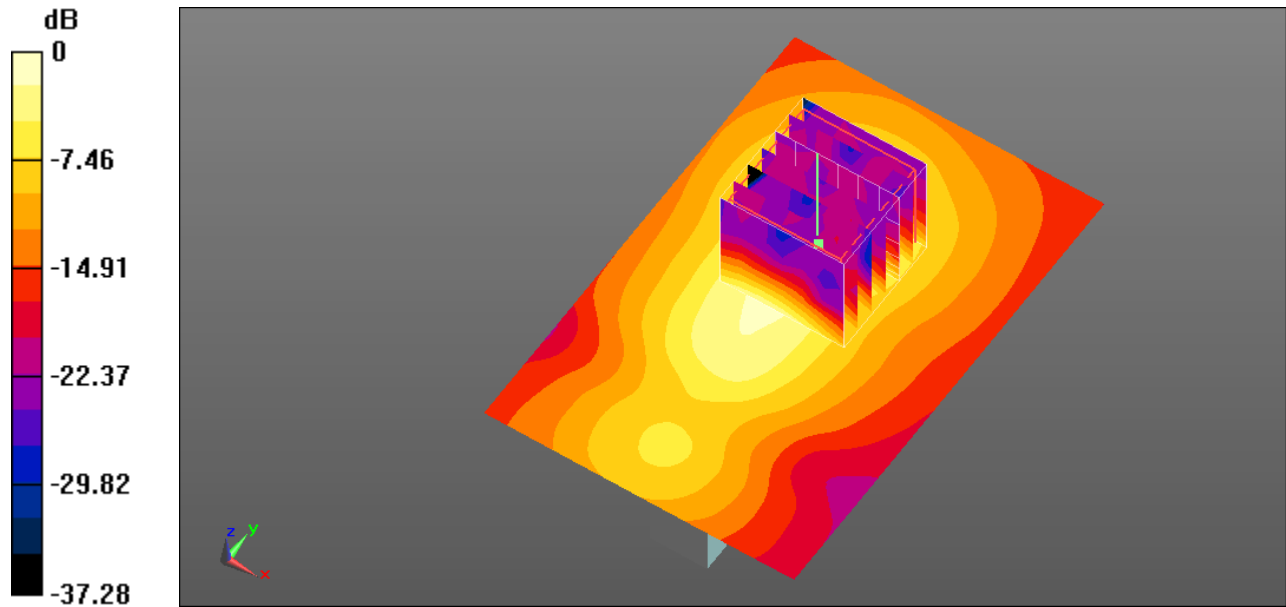

0 dB = 1.02 W/kg = 0.09 dBW/kg

Date: 2021/10/19

Test Laboratory: Underwriters Laboratories Taiwan Co., Ltd

Wi-Fi 5 GHz U-NII 2C_Verical-Front_Chain 0

Communication System: UID 0, 802.11a/ac 5GHz (0) (0); Communication System Band: 802.11a/ac;

Frequency: 5690 MHz; Communication System PAR: 0 dB; PMF: 1

Medium parameters used: $f = 5690$ MHz; $\sigma = 5.147$ S/m; $\epsilon_r = 33.963$; $\rho = 1000$ kg/m³

Phantom section: Flat Section

Measurement Standard: DASYS5 (IEEE/IEC/ANSI C63.19-2011)

DASY Configuration:

- Probe: EX3DV4 - SN3826; ConvF(4.68, 4.68, 4.68) @ 5690 MHz; Calibrated: 2021/7/28
 - Modulation Compensation:
- Sensor-Surface: 1.4mm (Mechanical Surface Detection), $z = -49.0, 22.0$
- Electronics: DAE3 Sn528; Calibrated: 2021/7/26
- Phantom: ELI v5.0_1213; Type: QDOVA001BB; Serial: 1213
- DASYS5 52.10.4(1527); SEMCAD X 14.6.14(7483)

802.11ac80/Area Scan (61x91x1): Interpolated grid: $dx=1.000$ mm, $dy=1.000$ mm

Maximum value of SAR (interpolated) = 2.62 W/kg

802.11ac80/Zoom Scan (7x7x7)/Cube 0: Measurement grid: $dx=4$ mm, $dy=4$ mm, $dz=1.4$ mm

Reference Value = 23.16 V/m; Power Drift = 0.12 dB

Peak SAR (extrapolated) = 5.19 W/kg

SAR(1 g) = 1.06 W/kg; SAR(10 g) = 0.327 W/kg

Smallest distance from peaks to all points 3 dB below = 7.5 mm

Ratio of SAR at M2 to SAR at M1 = 57.2%

Maximum value of SAR (measured) = 2.65 W/kg

802.11ac80/Zoom Scan (7x7x7)/Cube 1: Measurement grid: $dx=4$ mm, $dy=4$ mm, $dz=1.4$ mm

Reference Value = 23.16 V/m; Power Drift = 0.12 dB

Peak SAR (extrapolated) = 3.43 W/kg

SAR(1 g) = 0.692 W/kg; SAR(10 g) = 0.189 W/kg

Smallest distance from peaks to all points 3 dB below = 7.9 mm

Ratio of SAR at M2 to SAR at M1 = 58.2%

Maximum value of SAR (measured) = 1.82 W/kg

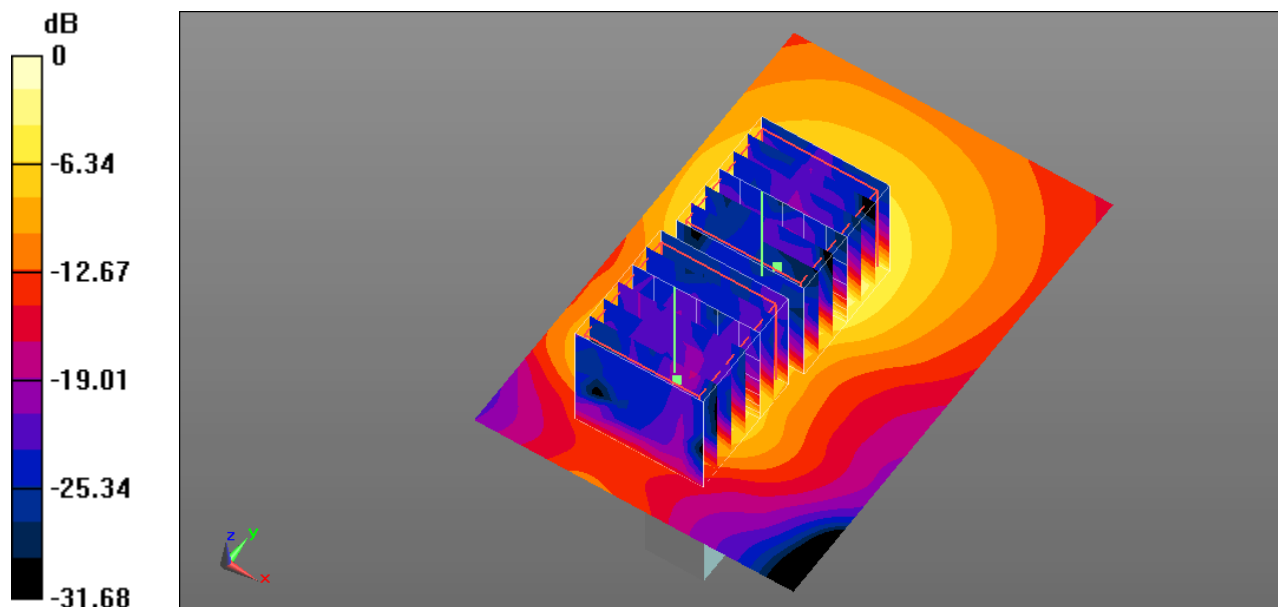

0 dB = 1.82 W/kg = 2.60 dBW/kg

Test Laboratory: Underwriters Laboratories Taiwan Co., Ltd

Wi-Fi 5 GHz U-NII 2C_Veritical-Back_Chain 1

Communication System: UID 0, 802.11a/ac 5GHz (0) (0); Communication System Band: 802.11a/ac;

Frequency: 5610 MHz; Communication System PAR: 0 dB; PMF: 1

Medium parameters used: $f = 5610$ MHz; $\sigma = 5.282$ S/m; $\epsilon_r = 34.028$; $\rho = 1000$ kg/m³

Phantom section: Flat Section

Measurement Standard: DASYS (IEEE/IEC/ANSI C63.19-2011)

DASY Configuration:

- Probe: EX3DV4 - SN3826; ConvF(4.68, 4.68, 4.68) @ 5610 MHz; Calibrated: 2021/7/28
 - Modulation Compensation:
- Sensor-Surface: 1.4mm (Mechanical Surface Detection), $z = -49.0, 22.0$
- Electronics: DAE3 Sn528; Calibrated: 2021/7/26
- Phantom: ELI v5.0_1213; Type: QDOVA001BB; Serial: 1213
- DASYS 52.10.4(1527); SEMCAD X 14.6.14(7483)

802.11ac80/Area Scan (61x91x1): Interpolated grid: $dx=1.000$ mm, $dy=1.000$ mm

Maximum value of SAR (interpolated) = 2.23 W/kg

802.11ac80/Zoom Scan (7x7x7)/Cube 0: Measurement grid: $dx=4$ mm, $dy=4$ mm, $dz=1.4$ mm

Reference Value = 20.50 V/m; Power Drift = -0.11 dB

Peak SAR (extrapolated) = 4.32 W/kg

SAR(1 g) = 0.929 W/kg; SAR(10 g) = 0.300 W/kg

Smallest distance from peaks to all points 3 dB below = 7.9 mm

Ratio of SAR at M2 to SAR at M1 = 58.9%

Maximum value of SAR (measured) = 2.28 W/kg

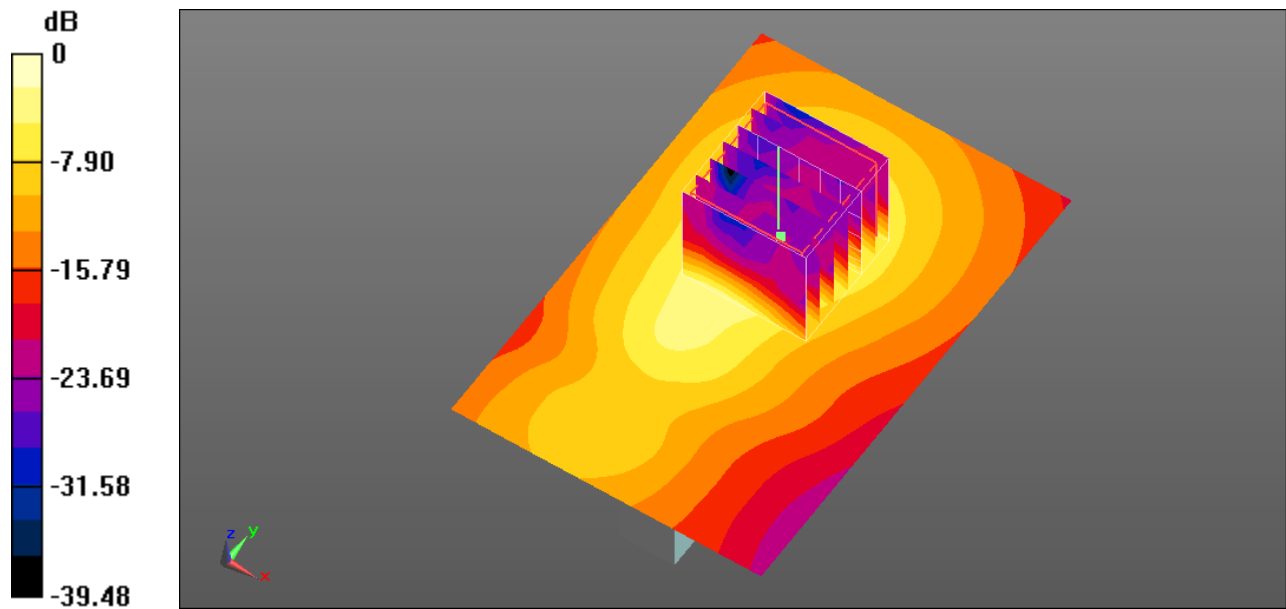

0 dB = 2.28 W/kg = 3.58 dBW/kg

Test Laboratory: Underwriters Laboratories Taiwan Co., Ltd

Wi-Fi 5 GHz U-NII 3_Horizontal-Up_Chain 0

Communication System: UID 0, 802.11a/ac 5GHz (0) (0); Communication System Band: 802.11a/ac;
 Frequency: 5775 MHz; Communication System PAR: 0 dB; PMF: 1

Medium parameters used: $f = 5775 \text{ MHz}$; $\sigma = 5.137 \text{ S/m}$; $\epsilon_r = 33.805$; $\rho = 1000 \text{ kg/m}^3$

Phantom section: Flat Section

Measurement Standard: DASYS5 (IEEE/IEC/ANSI C63.19-2011)

DASY Configuration:

- Probe: EX3DV4 - SN3826; ConvF(4.74, 4.74, 4.74) @ 5775 MHz; Calibrated: 2021/7/28
 - Modulation Compensation:
- Sensor-Surface: 1.4mm (Mechanical Surface Detection), $z = -49.0, 22.0$
- Electronics: DAE3 Sn528; Calibrated: 2021/7/26
- Phantom: ELI v5.0_1213; Type: QDOVA001BB; Serial: 1213
- DASYS5 52.10.4(1527); SEMCAD X 14.6.14(7483)

802.11ac80/Area Scan (61x91x1): Interpolated grid: $dx=1.000 \text{ mm}$, $dy=1.000 \text{ mm}$
 Maximum value of SAR (interpolated) = 2.28 W/kg

802.11ac80/Zoom Scan (7x7x7)/Cube 0: Measurement grid: $dx=4\text{mm}$, $dy=4\text{mm}$, $dz=1.4\text{mm}$
 Reference Value = 18.01 V/m; Power Drift = -0.06 dB
 Peak SAR (extrapolated) = 4.31 W/kg

SAR(1 g) = 0.862 W/kg; SAR(10 g) = 0.236 W/kg

Smallest distance from peaks to all points 3 dB below = 6.2 mm

Ratio of SAR at M2 to SAR at M1 = 58.3%

Maximum value of SAR (measured) = 2.22 W/kg

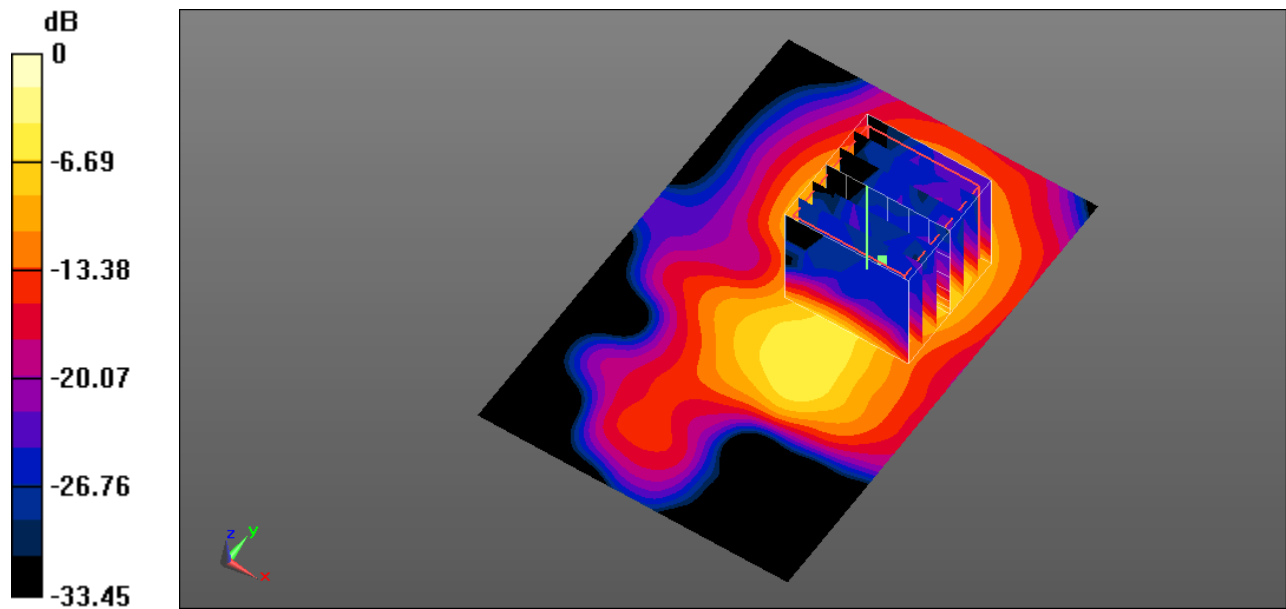

0 dB = 2.22 W/kg = 3.46 dBW/kg

Date: 2021/10/16

Test Laboratory: Underwriters Laboratories Taiwan Co., Ltd

Wi-Fi 5 GHz U-NII 3_Horizontal-Down_Chain 1

Communication System: UID 0, 802.11a/ac 5GHz (0) (0); Communication System Band: 802.11a/ac;

Frequency: 5775 MHz; Communication System PAR: 0 dB; PMF: 1

Medium parameters used: $f = 5775$ MHz; $\sigma = 5.137$ S/m; $\epsilon_r = 33.805$; $\rho = 1000$ kg/m³

Phantom section: Flat Section

Measurement Standard: DASYS (IEEE/IEC/ANSI C63.19-2011)

DASY Configuration:

- Probe: EX3DV4 - SN3826; ConvF(4.74, 4.74, 4.74) @ 5775 MHz; Calibrated: 2021/7/28
 - Modulation Compensation:
- Sensor-Surface: 1.4mm (Mechanical Surface Detection), $z = -49.0, 22.0$
- Electronics: DAE3 Sn528; Calibrated: 2021/7/26
- Phantom: ELI v5.0_1213; Type: QDOVA001BB; Serial: 1213
- DASYS 52.10.4(1527); SEMCAD X 14.6.14(7483)

802.11ac80/Area Scan (61x91x1): Interpolated grid: $dx=1.000$ mm, $dy=1.000$ mm

Maximum value of SAR (interpolated) = 1.70 W/kg

802.11ac80/Zoom Scan (7x7x7)/Cube 0: Measurement grid: $dx=4$ mm, $dy=4$ mm, $dz=1.4$ mm

Reference Value = 14.22 V/m; Power Drift = 0.07 dB

Peak SAR (extrapolated) = 3.29 W/kg

SAR(1 g) = 0.643 W/kg; SAR(10 g) = 0.175 W/kg

Smallest distance from peaks to all points 3 dB below = 6.8 mm

Ratio of SAR at M2 to SAR at M1 = 58%

Maximum value of SAR (measured) = 1.75 W/kg

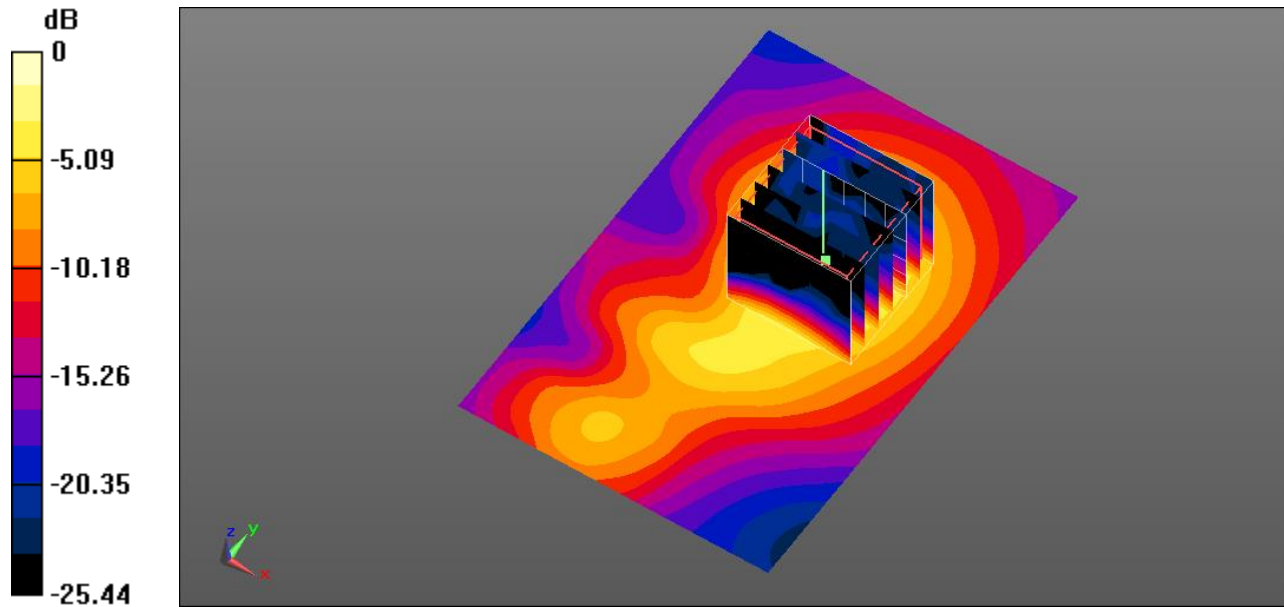

0 dB = 1.75 W/kg = 2.43 dBW/kg

Date: 2021/10/24

Test Laboratory: Underwriters Laboratories Taiwan Co., Ltd

Bluetooth_Horizontal-Down_Chain 1

Communication System: UID 0, Bluetooth (0); Communication System Band:Bluetooth; Frequency: 2402 MHz; Communication System PAR: 2.015 dB; PMF: 1

Medium parameters used: $f = 2402$ MHz; $\sigma = 1.761$ S/m; $\epsilon_r = 37.855$; $\rho = 1000$ kg/m³

Phantom section: Flat Section

Measurement Standard: DASYS5 (IEEE/IEC/ANSI C63.19-2011)

DASY Configuration:

- Probe: EX3DV4 - SN3826; ConvF(7.22, 7.22, 7.22) @ 2402 MHz; Calibrated: 2021/7/28
 - Modulation Compensation:
- Sensor-Surface: 1.4mm (Mechanical Surface Detection), $z = -49.0, 31.0$
- Electronics: DAE3 Sn528; Calibrated: 2021/7/26
- Phantom: ELI v5.0_1213; Type: QDOVA001BB; Serial: 1213
- DASYS5 52.10.4(1527); SEMCAD X 14.6.14(7483)

Bluetooth/Area Scan (51x71x1): Interpolated grid: $dx=1.200$ mm, $dy=1.200$ mm
Maximum value of SAR (interpolated) = 0.0867 W/kg

Bluetooth/Zoom Scan (7x7x7)/Cube 0: Measurement grid: $dx=5$ mm, $dy=5$ mm, $dz=5$ mm

Reference Value = 6.582 V/m; Power Drift = 0.11 dB

Peak SAR (extrapolated) = 0.100 W/kg

SAR(1 g) = 0.046 W/kg; SAR(10 g) = 0.022 W/kg

Smallest distance from peaks to all points 3 dB below: Larger than measurement grid

Ratio of SAR at M2 to SAR at M1 = 47.4%

Maximum value of SAR (measured) = 0.0773 W/kg

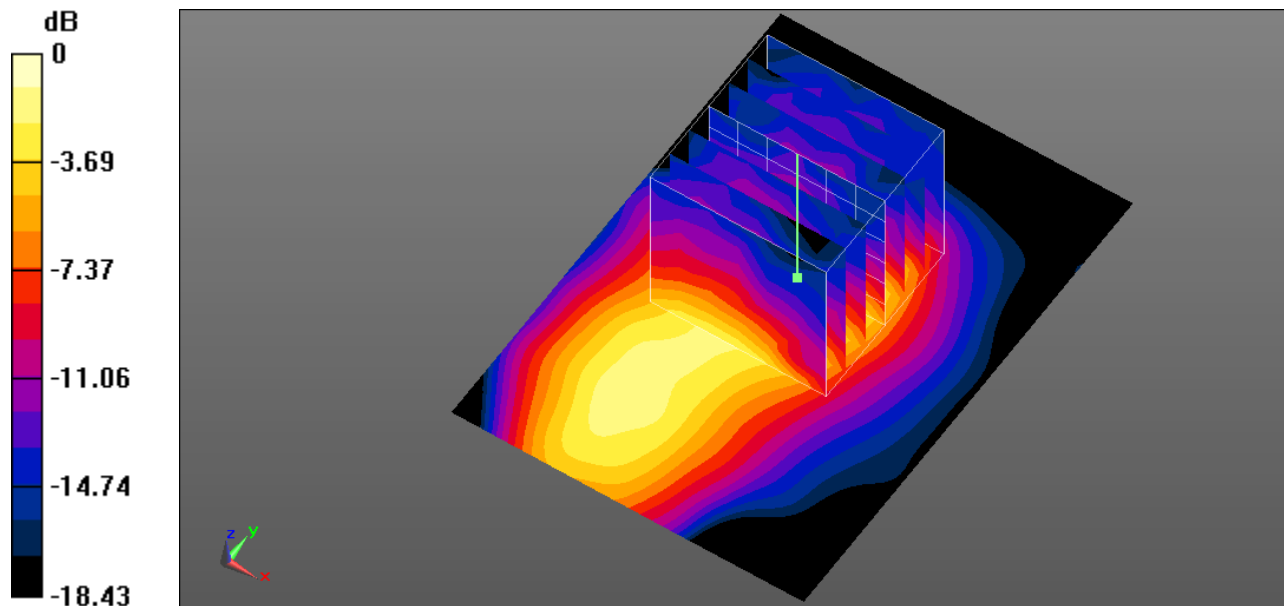

0 dB = 0.0773 W/kg = -11.12 dBW/kg

Test Laboratory: Underwriters Laboratories Taiwan Co., Ltd

Wi-Fi 5 GHz U-NII 2A_Veritical-Front_Chain 0_Repeat

Communication System: UID 0, 802.11a/ac 5GHz (0) (0); Communication System Band: 802.11a/ac;
 Frequency: 5280 MHz; Communication System PAR: 0 dB; PMF: 1

Medium parameters used: $f = 5280 \text{ MHz}$; $\sigma = 4.87 \text{ S/m}$; $\epsilon_r = 35.838$; $\rho = 1000 \text{ kg/m}^3$

Phantom section: Flat Section

Measurement Standard: DASYS5 (IEEE/IEC/ANSI C63.19-2011)

DASY Configuration:

- Probe: EX3DV4 - SN3826; ConvF(5.06, 5.06, 5.06) @ 5280 MHz; Calibrated: 2021/7/28
 - Modulation Compensation:
- Sensor-Surface: 1.4mm (Mechanical Surface Detection), $z = -49.0, 22.0$
- Electronics: DAE3 Sn528; Calibrated: 2021/7/26
- Phantom: ELI v5.0_1213; Type: QDOVA001BB; Serial: 1213
- DASYS5 52.10.4(1527); SEMCAD X 14.6.14(7483)

802.11n20/Area Scan (61x91x1): Interpolated grid: $dx=1.000 \text{ mm}$, $dy=1.000 \text{ mm}$
 Maximum value of SAR (interpolated) = 2.00 W/kg

802.11n20/Zoom Scan (7x7x7)/Cube 0: Measurement grid: $dx=4\text{mm}$, $dy=4\text{mm}$, $dz=1.4\text{mm}$
 Reference Value = 18.52 V/m; Power Drift = 0.18 dB

Peak SAR (extrapolated) = 3.51 W/kg

SAR(1 g) = 0.848 W/kg; SAR(10 g) = 0.273 W/kg

Smallest distance from peaks to all points 3 dB below = 8.8 mm

Ratio of SAR at M2 to SAR at M1 = 62%

Maximum value of SAR (measured) = 2.02 W/kg

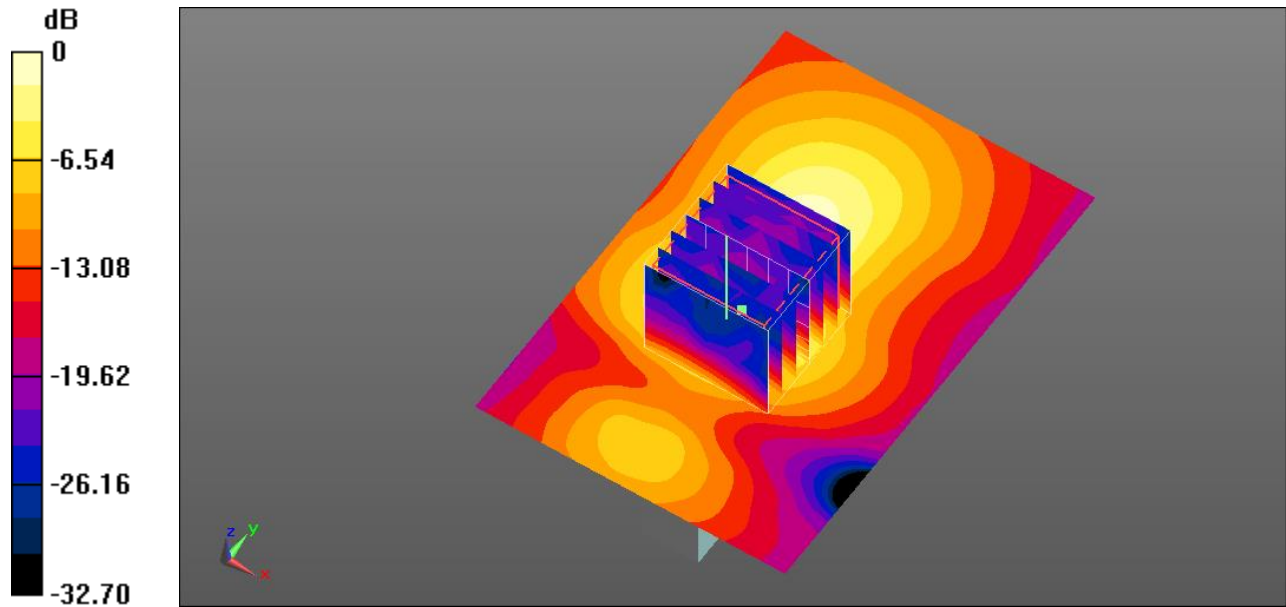

0 dB = 2.02 W/kg = 3.05 dBW/kg

Date: 2021/10/19

Test Laboratory: Underwriters Laboratories Taiwan Co., Ltd

Wi-Fi 5 GHz U-NII 2C_Veritical-Front_Chain 0_Repeat

Communication System: UID 0, 802.11a/ac 5GHz (0) (0); Communication System Band: 802.11a/ac;

Frequency: 5690 MHz; Communication System PAR: 0 dB; PMF: 1

Medium parameters used: $f = 5690$ MHz; $\sigma = 5.147$ S/m; $\epsilon_r = 33.963$; $\rho = 1000$ kg/m³

Phantom section: Flat Section

Measurement Standard: DASYS5 (IEEE/IEC/ANSI C63.19-2011)

DASY Configuration:

- Probe: EX3DV4 - SN3826; ConvF(4.68, 4.68, 4.68) @ 5690 MHz; Calibrated: 2021/7/28
 - Modulation Compensation:
- Sensor-Surface: 1.4mm (Mechanical Surface Detection), $z = -49.0, 22.0$
- Electronics: DAE3 Sn528; Calibrated: 2021/7/26
- Phantom: ELI v5.0_1213; Type: QDOVA001BB; Serial: 1213
- DASYS5 52.10.4(1527); SEMCAD X 14.6.14(7483)

802.11ac80/Area Scan (61x91x1): Interpolated grid: $dx=1.000$ mm, $dy=1.000$ mm

Maximum value of SAR (interpolated) = 2.45 W/kg

802.11ac80/Zoom Scan (7x7x7)/Cube 0: Measurement grid: $dx=4$ mm, $dy=4$ mm, $dz=1.4$ mm

Reference Value = 23.26 V/m; Power Drift = 0.08 dB

Peak SAR (extrapolated) = 4.57 W/kg

SAR(1 g) = 1.01 W/kg; SAR(10 g) = 0.345 W/kg

Smallest distance from peaks to all points 3 dB below = 9.1 mm

Ratio of SAR at M2 to SAR at M1 = 58.4%

Maximum value of SAR (measured) = 2.48 W/kg

Bottom/802.11ac80/Zoom Scan (7x7x7)/Cube 1: Measurement grid: $dx=4$ mm, $dy=4$ mm, $dz=1.4$ mm

Reference Value = 23.26 V/m; Power Drift = 0.08 dB

Peak SAR (extrapolated) = 3.55 W/kg

SAR(1 g) = 0.763 W/kg; SAR(10 g) = 0.229 W/kg

Smallest distance from peaks to all points 3 dB below = 8.6 mm

Ratio of SAR at M2 to SAR at M1 = 58.9%

Maximum value of SAR (measured) = 1.94 W/kg

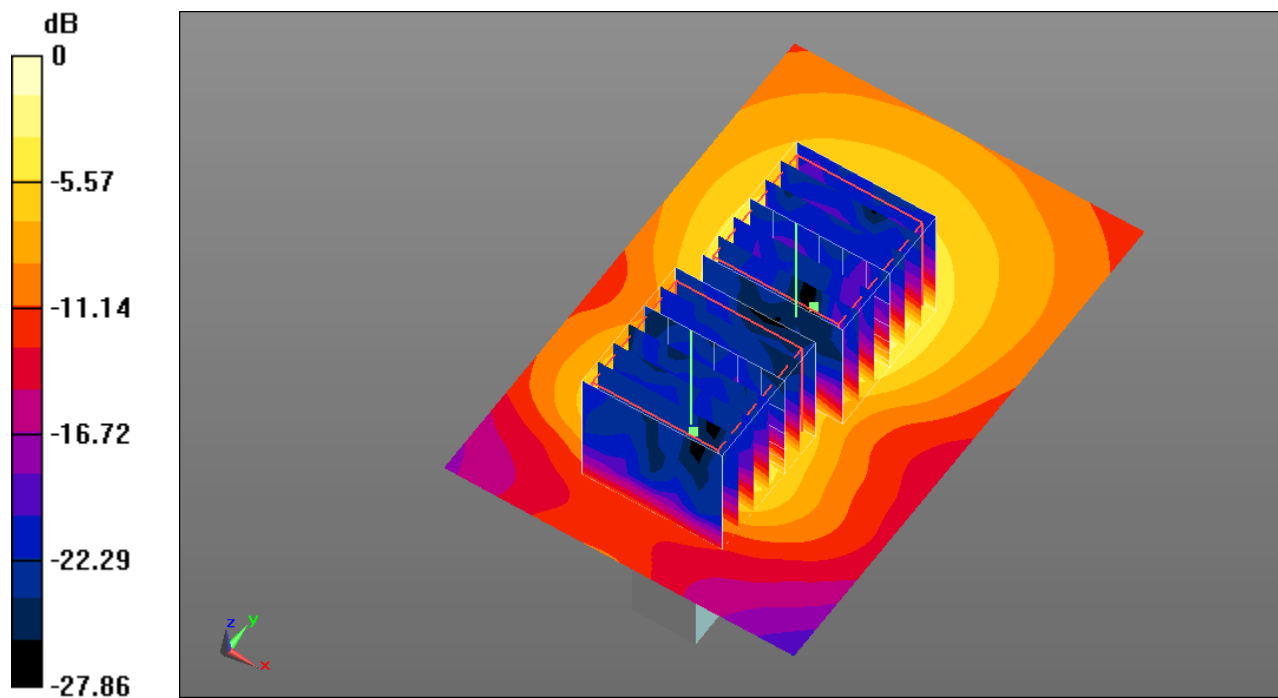

0 dB = 1.94 W/kg = 2.88 dBW/kg

Date: 2021/10/21

Test Laboratory: Underwriters Laboratories Taiwan Co., Ltd

Wi-Fi 5 GHz U-NII 3_Horizontal-Up_Chain 0_Repeat

Communication System: UID 0, 802.11a/ac 5GHz (0) (0); Communication System Band: 802.11a/ac;

Frequency: 5775 MHz; Communication System PAR: 0 dB; PMF: 1

Medium parameters used: $f = 5775$ MHz; $\sigma = 5.092$ S/m; $\epsilon_r = 34.162$; $\rho = 1000$ kg/m³

Phantom section: Flat Section

Measurement Standard: DASYS5 (IEEE/IEC/ANSI C63.19-2011)

DASY Configuration:

- Probe: EX3DV4 - SN3826; ConvF(4.74, 4.74, 4.74) @ 5775 MHz; Calibrated: 2021/7/28
 - Modulation Compensation:
- Sensor-Surface: 1.4mm (Mechanical Surface Detection), $z = -49.0, 22.0$
- Electronics: DAE3 Sn528; Calibrated: 2021/7/26
- Phantom: ELI v5.0_1213; Type: QDOVA001BB; Serial: 1213
- DASYS5 52.10.4(1527); SEMCAD X 14.6.14(7483)

802.11ac80/Area Scan (61x91x1): Interpolated grid: $dx=1.000$ mm, $dy=1.000$ mm

Maximum value of SAR (interpolated) = 1.71 W/kg

802.11ac80/Zoom Scan (7x7x7)/Cube 0: Measurement grid: $dx=4$ mm, $dy=4$ mm, $dz=1.4$ mm

Reference Value = 18.39 V/m; Power Drift = -0.09 dB

Peak SAR (extrapolated) = 3.43 W/kg

SAR(1 g) = 0.781 W/kg; SAR(10 g) = 0.247 W/kg

Smallest distance from peaks to all points 3 dB below = 7.2 mm

Ratio of SAR at M2 to SAR at M1 = 60.7%

Maximum value of SAR (measured) = 1.92 W/kg

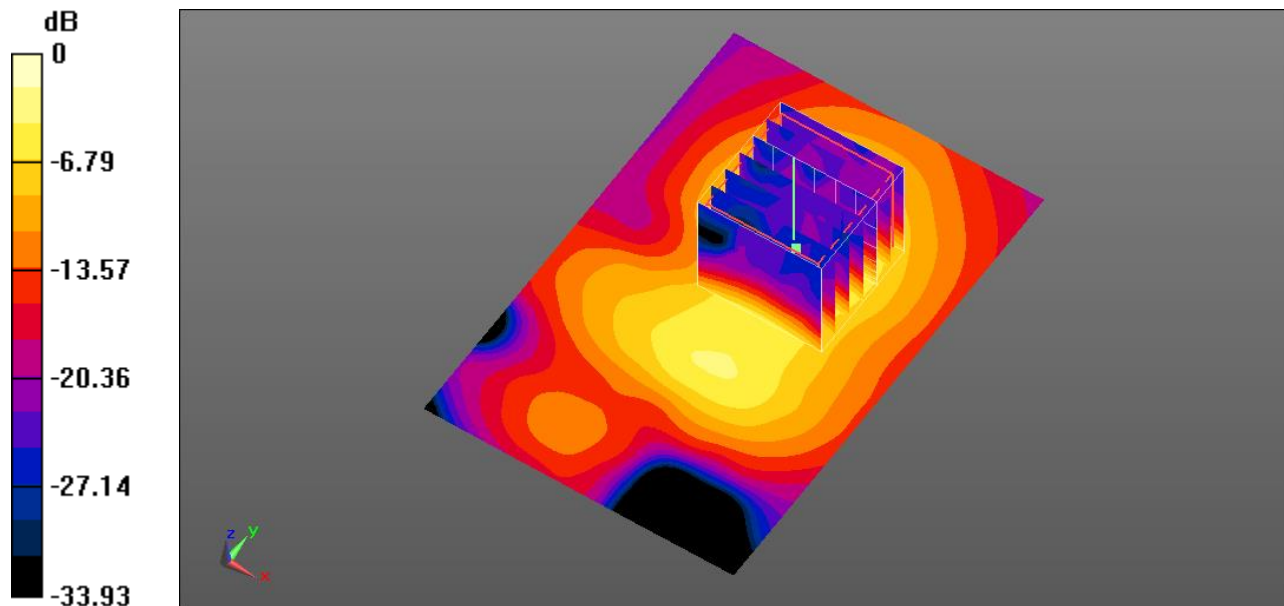

0 dB = 1.92 W/kg = 2.83 dBW/kg

Appendix D: SAR Probe and Dipole Calibration Certificates



In Collaboration with
s p e a g
CALIBRATION LABORATORY



中国认可
国际互认
校准
CALIBRATION
CNAS L0570

Add: No.51 Xueyuan Road, Haidian District, Beijing, 100191, China
Tel: +86-10-62304633-2512 Fax: +86-10-62304633-2504
E-mail: cttl@chinattl.com http://www.chinattl.cn

Client

UL

Certificate No: Z20-60448

CALIBRATION CERTIFICATE

Object: D5GHzV2 - SN: 1244

Calibration Procedure(s): FF-Z11-003-01
Calibration Procedures for dipole validation kits

Calibration date: November 10, 2020

This calibration Certificate documents the traceability to national standards, which realize the physical units of measurements(SI). The measurements and the uncertainties with confidence probability are given on the following pages and are part of the certificate.

All calibrations have been conducted in the closed laboratory facility: environment temperature(22±3)°C and humidity<70%.

Calibration Equipment used (M&TE critical for calibration)

Primary Standards	ID #	Cal Date(Calibrated by, Certificate No.)	Scheduled Calibration
Power Meter NRP2	106276	12-May-20 (CTTL, No.J20X02965)	May-21
Power sensor NRP6A	101369	12-May-20 (CTTL, No.J20X02965)	May-21
ReferenceProbe EX3DV4	SN 3617	30-Jan-20(SPEAG,No.EX3-3617_Jan20)	Jan-21
DAE4	SN 771	10-Feb-20(CTTL-SPEAG,No.Z20-60017)	Feb-21
Secondary Standards	ID #	Cal Date(Calibrated by, Certificate No.)	Scheduled Calibration
Signal Generator E4438C	MY49071430	25-Feb-20 (CTTL, No.J20X00516)	Feb-21
NetworkAnalyzerE5071C	MY46107873	10-Feb-20 (CTTL, No.J20X00515)	Feb-21

	Name	Function	Signature
Calibrated by:	Zhao Jing	SAR Test Engineer	
Reviewed by:	Lin Hao	SAR Test Engineer	
Approved by:	Qi Dianyuan	SAR Project Leader	

Issued: November 19, 2020

This calibration certificate shall not be reproduced except in full without written approval of the laboratory.



Glossary:

TSL	tissue simulating liquid
ConvF	sensitivity in TSL / NORM _{x,y,z}
N/A	not applicable or not measured

Calibration is Performed According to the Following Standards:

- IEEE Std 1528-2013, "IEEE Recommended Practice for Determining the Peak Spatial-Averaged Specific Absorption Rate (SAR) in the Human Head from Wireless Communications Devices: Measurement Techniques", June 2013
- IEC 62209-1, "Measurement procedure for assessment of specific absorption rate of human exposure to radio frequency fields from hand-held and body-mounted wireless communication devices- Part 1: Device used next to the ear (Frequency range of 300MHz to 6GHz)", July 2016
- IEC 62209-2, "Procedure to measure the Specific Absorption Rate (SAR) For wireless communication devices used in close proximity to the human body (frequency range of 30MHz to 6GHz)", March 2010
- KDB865664, SAR Measurement Requirements for 100 MHz to 6 GHz

Additional Documentation:

- DASY4/5 System Handbook

Methods Applied and Interpretation of Parameters:

- Measurement Conditions:** Further details are available from the Validation Report at the end of the certificate. All figures stated in the certificate are valid at the frequency indicated.
- Antenna Parameters with TSL:** The dipole is mounted with the spacer to position its feed point exactly below the center marking of the flat phantom section, with the arms oriented parallel to the body axis.
- Feed Point Impedance and Return Loss:** These parameters are measured with the dipole positioned under the liquid filled phantom. The impedance stated is transformed from the measurement at the SMA connector to the feed point. The Return Loss ensures low reflected power. No uncertainty required.
- Electrical Delay:** One-way delay between the SMA connector and the antenna feed point. No uncertainty required.
- SAR measured:** SAR measured at the stated antenna input power.
- SAR normalized:** SAR as measured, normalized to an input power of 1 W at the antenna connector.
- SAR for nominal TSL parameters:** The measured TSL parameters are used to calculate the nominal SAR result.

The reported uncertainty of measurement is stated as the standard uncertainty of Measurement multiplied by the coverage factor $k=2$, which for a normal distribution Corresponds to a coverage probability of approximately 95%.



Add: No.51 Xueyuan Road, Haidian District, Beijing, 100191, China
 Tel: +86-10-62304633-2512 Fax: +86-10-62304633-2504
 E-mail: cttl@chinattl.com http://www.chinattl.cn

Measurement Conditions

DASY system configuration, as far as not given on page 1.

DASY Version	DASY52	V52.10.4
Extrapolation	Advanced Extrapolation	
Phantom	Triple Flat Phantom 5.1C	
Distance Dipole Center - TSL	10 mm	with Spacer
Zoom Scan Resolution	dx, dy = 4 mm, dz = 1.4 mm	Graded Ratio = 1.4 (Z direction)
Frequency	5250 MHz ± 1 MHz 5300 MHz ± 1 MHz 5600 MHz ± 1 MHz 5800 MHz ± 1 MHz	

Head TSL parameters at 5250 MHz

The following parameters and calculations were applied.

	Temperature	Permittivity	Conductivity
Nominal Head TSL parameters	22.0 °C	35.9	4.71 mho/m
Measured Head TSL parameters	(22.0 ± 0.2) °C	35.1 ± 6 %	4.76 mho/m ± 6 %
Head TSL temperature change during test	<1.0 °C	----	----

SAR result with Head TSL at 5250 MHz

SAR averaged over 1 cm³ (1 g) of Head TSL	Condition	
SAR measured	100 mW input power	7.73 W/kg
SAR for nominal Head TSL parameters	normalized to 1W	77.0 W/kg ± 24.4 % (k=2)
SAR averaged over 10 cm³ (10 g) of Head TSL	Condition	
SAR measured	100 mW input power	2.21 W/kg
SAR for nominal Head TSL parameters	normalized to 1W	22.0 W/kg ± 24.2 % (k=2)



Add: No.51 Xueyuan Road, Haidian District, Beijing, 100191, China
 Tel: +86-10-62304633-2512 Fax: +86-10-62304633-2504
 E-mail: cttl@chinattl.com http://www.chinattl.cn

Head TSL parameters at 5300 MHz

The following parameters and calculations were applied.

	Temperature	Permittivity	Conductivity
Nominal Head TSL parameters	22.0 °C	35.9	4.76 mho/m
Measured Head TSL parameters	(22.0 ± 0.2) °C	35.0 ± 6 %	4.81 mho/m ± 6 %
Head TSL temperature change during test	<1.0 °C	----	----

SAR result with Head TSL at 5300 MHz

SAR averaged over 1 cm³ (1 g) of Head TSL	Condition	
SAR measured	100 mW input power	7.85 W/kg
SAR for nominal Head TSL parameters	normalized to 1W	78.1 W/kg ± 24.4 % (k=2)
SAR averaged over 10 cm³ (10 g) of Head TSL	Condition	
SAR measured	100 mW input power	2.25 W/kg
SAR for nominal Head TSL parameters	normalized to 1W	22.4 W/kg ± 24.2 % (k=2)

Head TSL parameters at 5600 MHz

The following parameters and calculations were applied.

	Temperature	Permittivity	Conductivity
Nominal Head TSL parameters	22.0 °C	35.5	5.07 mho/m
Measured Head TSL parameters	(22.0 ± 0.2) °C	34.5 ± 6 %	5.14 mho/m ± 6 %
Head TSL temperature change during test	<1.0 °C	----	----

SAR result with Head TSL at 5600 MHz

SAR averaged over 1 cm³ (1 g) of Head TSL	Condition	
SAR measured	100 mW input power	8.10 W/kg
SAR for nominal Head TSL parameters	normalized to 1W	80.6 W/kg ± 24.4 % (k=2)
SAR averaged over 10 cm³ (10 g) of Head TSL	Condition	
SAR measured	100 mW input power	2.31 W/kg
SAR for nominal Head TSL parameters	normalized to 1W	23.0 W/kg ± 24.2 % (k=2)



Add: No.51 Xueyuan Road, Haidian District, Beijing, 100191, China
Tel: +86-10-62304633-2512 Fax: +86-10-62304633-2504
E-mail: cttl@chinattl.com http://www.chinattl.cn

Head TSL parameters at 5800 MHz

The following parameters and calculations were applied.

	Temperature	Permittivity	Conductivity
Nominal Head TSL parameters	22.0 °C	35.3	5.27 mho/m
Measured Head TSL parameters	(22.0 ± 0.2) °C	34.3 ± 6 %	5.31 mho/m ± 6 %
Head TSL temperature change during test	<1.0 °C	----	----

SAR result with Head TSL at 5800 MHz

SAR averaged over 1 cm³ (1 g) of Head TSL	Condition	
SAR measured	100 mW input power	7.81 W/kg
SAR for nominal Head TSL parameters	normalized to 1W	77.7 W/kg ± 24.4 % (k=2)
SAR averaged over 10 cm³ (10 g) of Head TSL	Condition	
SAR measured	100 mW input power	2.22 W/kg
SAR for nominal Head TSL parameters	normalized to 1W	22.0 W/kg ± 24.2 % (k=2)



Add: No.51 Xueyuan Road, Haidian District, Beijing, 100191, China
Tel: +86-10-62304633-2512 Fax: +86-10-62304633-2504
E-mail: cttl@chinattl.com http://www.chinattl.cn

Appendix (Additional assessments outside the scope of CNAS L0570)

Antenna Parameters with Head TSL at 5250 MHz

Impedance, transformed to feed point	50.8 Ω - 4.35j Ω
Return Loss	- 27.2dB

Antenna Parameters with Head TSL at 5300 MHz

Impedance, transformed to feed point	49.2 Ω - 2.62j Ω
Return Loss	- 31.1dB

Antenna Parameters with Head TSL at 5600 MHz

Impedance, transformed to feed point	51.9 Ω - 0.76j Ω
Return Loss	- 34.1dB

Antenna Parameters with Head TSL at 5800 MHz

Impedance, transformed to feed point	51.3 Ω + 0.91j Ω
Return Loss	- 36.2dB

General Antenna Parameters and Design

Electrical Delay (one direction)	1.062 ns
----------------------------------	----------

After long term use with 100W radiated power, only a slight warming of the dipole near the feedpoint can be measured.

The dipole is made of standard semirigid coaxial cable. The center conductor of the feeding line is directly connected to the second arm of the dipole. The antenna is therefore short-circuited for DC-signals. On some of the dipoles, small end caps are added to the dipole arms in order to improve matching when loaded according to the position as explained in the "Measurement Conditions" paragraph. The SAR data are not affected by this change. The overall dipole length is still according to the Standard.

No excessive force must be applied to the dipole arms, because they might bend or the soldered connections near the feedpoint may be damaged.

Additional EUT Data

Manufactured by	SPEAG
-----------------	-------



DASY5 Validation Report for Head TSL

Date: 11.10.2020

Test Laboratory: CTTL, Beijing, China

DUT: Dipole 5GHz; Type: D5GHzV2; Serial: D5GHzV2 - SN: 1244

Communication System: CW; Frequency: 5250 MHz, Frequency: 5300 MHz,
Frequency: 5600 MHz, Frequency: 5800 MHz,

Medium parameters used: $f = 5250$ MHz; $\sigma = 4.756$ S/m; $\epsilon_r = 35.12$; $\rho = 1000$ kg/m³, Medium parameters used: $f = 5300$ MHz; $\sigma = 4.813$ S/m; $\epsilon_r = 35.03$; $\rho = 1000$ kg/m³, Medium parameters used: $f = 5600$ MHz; $\sigma = 5.14$ S/m; $\epsilon_r = 34.53$; $\rho = 1000$ kg/m³, Medium parameters used: $f = 5800$ MHz; $\sigma = 5.306$ S/m; $\epsilon_r = 34.3$; $\rho = 1000$ kg/m³,

Phantom section: Center Section

DASY5 Configuration:

- Probe: EX3DV4 - SN3617; ConvF(5.39, 5.39, 5.39) @ 5250 MHz; ConvF(5.29, 5.29, 5.29) @ 5300 MHz; ConvF(4.99, 4.99, 4.99) @ 5600 MHz; ConvF(5, 5, 5) @ 5800 MHz; Calibrated: 2020-01-30
- Sensor-Surface: 1.4mm (Mechanical Surface Detection)
- Electronics: DAE4 Sn771; Calibrated: 2020-02-10
- Phantom: MFP_V5.1C (20deg probe tilt); Type: QD 000 P51 Cx; Serial: 1062
- Measurement SW: DASY52, Version 52.10 (4); SEMCAD X Version 14.6.14 (7483)

Dipole Calibration /Pin=100mW, d=10mm, f=5250 MHz/Zoom Scan, dist=1.4mm (8x8x7)/Cube 0: Measurement grid: dx=4mm, dy=4mm, dz=1.4mm
Reference Value = 70.66 V/m; Power Drift = -0.04 dB
Peak SAR (extrapolated) = 31.0 W/kg
SAR(1 g) = 7.73 W/kg; SAR(10 g) = 2.21 W/kg
Smallest distance from peaks to all points 3 dB below = 7.2 mm
Ratio of SAR at M2 to SAR at M1 = 65.4%
Maximum value of SAR (measured) = 18.1 W/kg

Dipole Calibration /Pin=100mW, d=10mm, f=5300 MHz/Zoom Scan, dist=1.4mm (8x8x7)/Cube 0: Measurement grid: dx=4mm, dy=4mm, dz=1.4mm
Reference Value = 70.56 V/m; Power Drift = -0.07 dB
Peak SAR (extrapolated) = 31.8 W/kg
SAR(1 g) = 7.85 W/kg; SAR(10 g) = 2.25 W/kg
Smallest distance from peaks to all points 3 dB below = 7.2 mm
Ratio of SAR at M2 to SAR at M1 = 64.9%
Maximum value of SAR (measured) = 18.4 W/kg



Add: No.51 Xueyuan Road, Haidian District, Beijing, 100191, China
Tel: +86-10-62304633-2512 Fax: +86-10-62304633-2504
E-mail: cttl@chinattl.com http://www.chinattl.cn

**Dipole Calibration /Pin=100mW, d=10mm, f=5600 MHz/Zoom Scan,
dist=1.4mm (8x8x7)/Cube 0: Measurement grid: dx=4mm, dy=4mm, dz=1.4mm
Reference Value = 70.49 V/m; Power Drift = -0.05 dB
Peak SAR (extrapolated) = 36.0 W/kg
SAR(1 g) = 8.1 W/kg; SAR(10 g) = 2.31 W/kg
Smallest distance from peaks to all points 3 dB below = 7.2 mm
Ratio of SAR at M2 to SAR at M1 = 61.9%
Maximum value of SAR (measured) = 19.9 W/kg**

**Dipole Calibration /Pin=100mW, d=10mm, f=5800 MHz/Zoom Scan,
dist=1.4mm (8x8x7)/Cube 0: Measurement grid: dx=4mm, dy=4mm, dz=1.4mm
Reference Value = 67.57 V/m; Power Drift = -0.09 dB
Peak SAR (extrapolated) = 35.7 W/kg
SAR(1 g) = 7.81 W/kg; SAR(10 g) = 2.22 W/kg
Smallest distance from peaks to all points 3 dB below = 7.2 mm
Ratio of SAR at M2 to SAR at M1 = 60.7%
Maximum value of SAR (measured) = 19.8 W/kg**

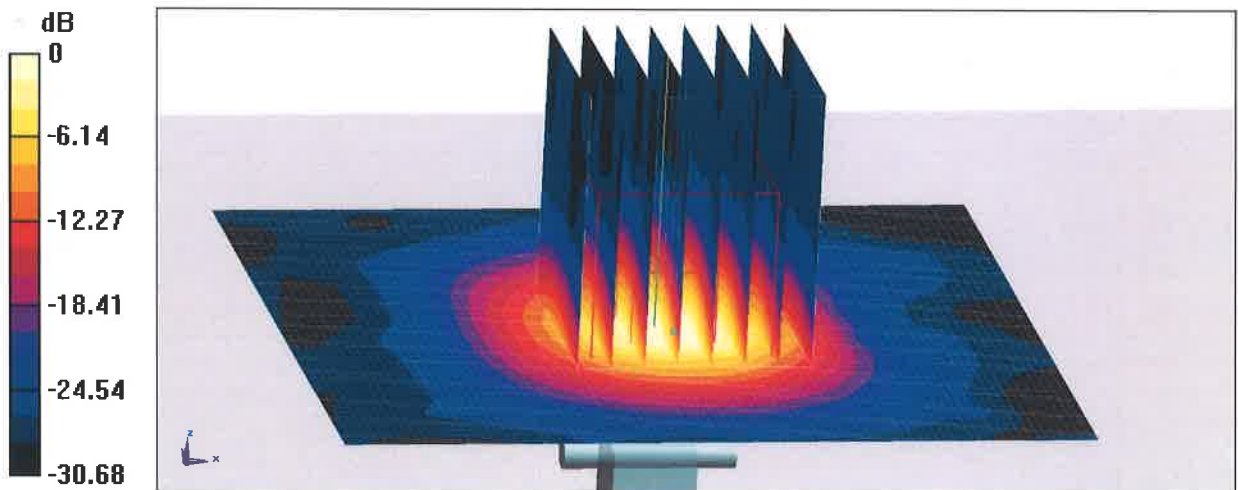

0 dB = 19.8 W/kg = 12.97 dBW/kg



Add: No.51 Xueyuan Road, Haidian District, Beijing, 100191, China
Tel: +86-10-62304633-2512 Fax: +86-10-62304633-2504
E-mail: cttl@chinattl.com http://www.chinattl.cn

Impedance Measurement Plot for Head TSL

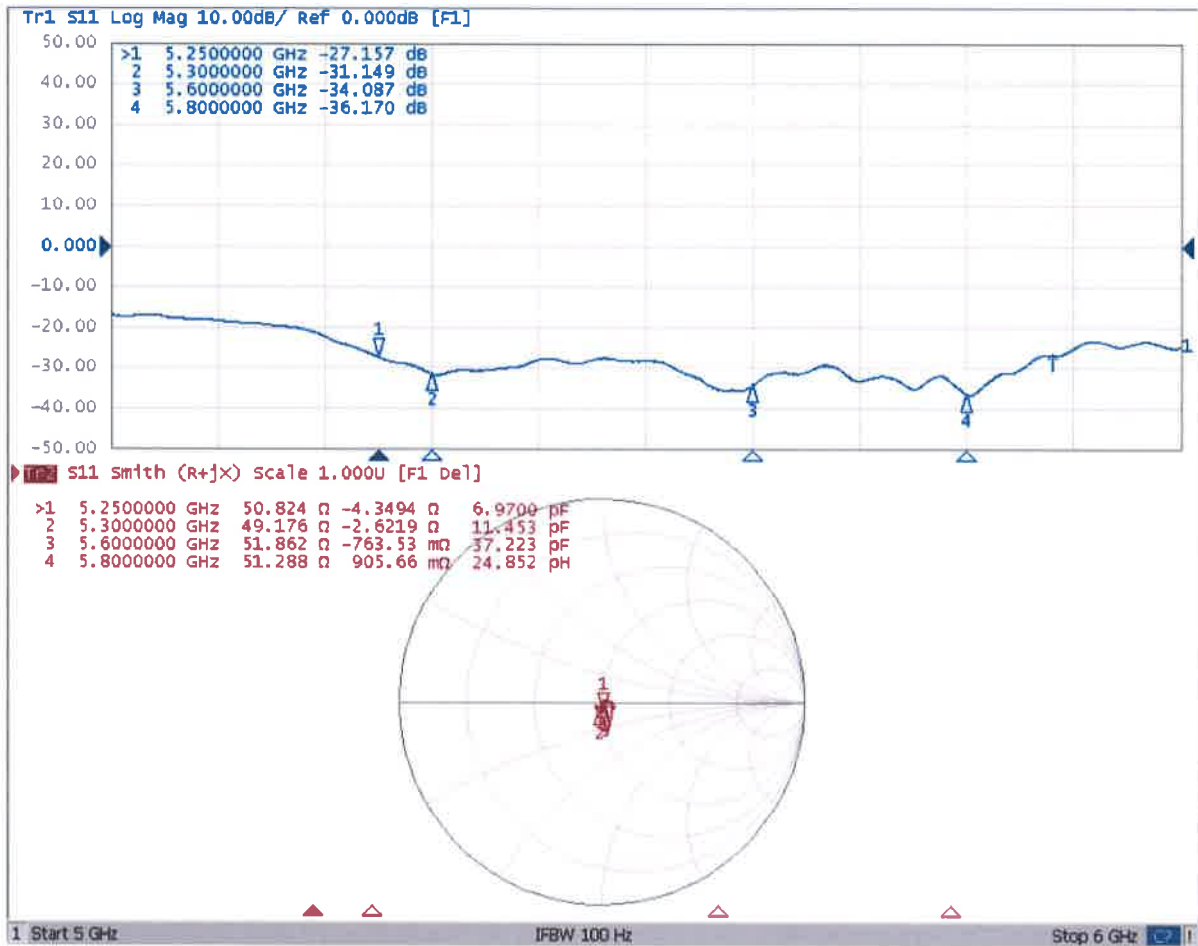



In Collaboration with
S p e a g
CALIBRATION LABORATORY



中国认可
国际互认
校准
CALIBRATION
CNAS L0570

Add: No.51 Xueyuan Road, Haidian District, Beijing, 100191, China
Tel: +86-10-62304633-2079 Fax: +86-10-62304633-2504
E-mail: cttl@chinattl.com http://www.chinattl.cn

Client

UL

Certificate No: Z20-60445

CALIBRATION CERTIFICATE

Object D2450V2 - SN: 988

Calibration Procedure(s) FF-Z11-003-01
Calibration Procedures for dipole validation kits

Calibration date: November 10, 2020

This calibration Certificate documents the traceability to national standards, which realize the physical units of measurements(SI). The measurements and the uncertainties with confidence probability are given on the following pages and are part of the certificate.

All calibrations have been conducted in the closed laboratory facility: environment temperature(22±3)°C and humidity<70%.

Calibration Equipment used (M&TE critical for calibration)

Primary Standards	ID #	Cal Date(Calibrated by, Certificate No.)	Scheduled Calibration
Power Meter NRP2	106276	12-May-20 (CTTL, No.J20X02965)	May-21
Power sensor NRP6A	101369	12-May-20 (CTTL, No.J20X02965)	May-21
ReferenceProbe EX3DV4	SN 3617	30-Jan-20(SPEAG,No.EX3-3617_Jan20)	Jan-21
DAE4	SN 771	10-Feb-20(CTTL-SPEAG,No.Z20-60017)	Feb-21
Secondary Standards	ID #	Cal Date(Calibrated by, Certificate No.)	Scheduled Calibration
Signal Generator E4438C	MY49071430	25-Feb-20 (CTTL, No.J20X00516)	Feb-21
NetworkAnalyzer E5071C	MY46110673	10-Feb-20 (CTTL, No.J20X00515)	Feb-21

	Name	Function	Signature
Calibrated by:	Zhao Jing	SAR Test Engineer	
Reviewed by:	Lin Hao	SAR Test Engineer	
Approved by:	Qi Dianyuan	SAR Project Leader	

Issued: November 19, 2020

This calibration certificate shall not be reproduced except in full without written approval of the laboratory.



In Collaboration with

s p e a g
CALIBRATION LABORATORY

Add: No.51 Xueyuan Road, Haidian District, Beijing, 100191, China
Tel: +86-10-62304633-2079 Fax: +86-10-62304633-2504
E-mail: cttl@chinattl.com http://www.chinattl.cn

Glossary:

TSL	tissue simulating liquid
ConvF	sensitivity in TSL / NORM _{x,y,z}
N/A	not applicable or not measured

Calibration is Performed According to the Following Standards:

- IEEE Std 1528-2013, "IEEE Recommended Practice for Determining the Peak Spatial-Averaged Specific Absorption Rate (SAR) in the Human Head from Wireless Communications Devices: Measurement Techniques", June 2013
- IEC 62209-1, "Measurement procedure for assessment of specific absorption rate of human exposure to radio frequency fields from hand-held and body-mounted wireless communication devices- Part 1: Device used next to the ear (Frequency range of 300MHz to 6GHz)", July 2016
- IEC 62209-2, "Procedure to measure the Specific Absorption Rate (SAR) For wireless communication devices used in close proximity to the human body (frequency range of 30MHz to 6GHz)", March 2010
- KDB865664, SAR Measurement Requirements for 100 MHz to 6 GHz

Additional Documentation:

- DASY4/5 System Handbook

Methods Applied and Interpretation of Parameters:

- Measurement Conditions:** Further details are available from the Validation Report at the end of the certificate. All figures stated in the certificate are valid at the frequency indicated.
- Antenna Parameters with TSL:** The dipole is mounted with the spacer to position its feed point exactly below the center marking of the flat phantom section, with the arms oriented parallel to the body axis.
- Feed Point Impedance and Return Loss:** These parameters are measured with the dipole positioned under the liquid filled phantom. The impedance stated is transformed from the measurement at the SMA connector to the feed point. The Return Loss ensures low reflected power. No uncertainty required.
- Electrical Delay:** One-way delay between the SMA connector and the antenna feed point. No uncertainty required.
- SAR measured:** SAR measured at the stated antenna input power.
- SAR normalized:** SAR as measured, normalized to an input power of 1 W at the antenna connector.
- SAR for nominal TSL parameters:** The measured TSL parameters are used to calculate the nominal SAR result.

The reported uncertainty of measurement is stated as the standard uncertainty of Measurement multiplied by the coverage factor $k=2$, which for a normal distribution Corresponds to a coverage probability of approximately 95%.



Add: No.51 Xueyuan Road, Haidian District, Beijing, 100191, China
 Tel: +86-10-62304633-2079 Fax: +86-10-62304633-2504
 E-mail: cttl@chinattl.com http://www.chinattl.cn

Measurement Conditions

DASY system configuration, as far as not given on page 1.

DASY Version	DASY52	V52.10.4
Extrapolation	Advanced Extrapolation	
Phantom	Triple Flat Phantom 5.1C	
Distance Dipole Center - TSL	10 mm	with Spacer
Zoom Scan Resolution	dx, dy, dz = 5 mm	
Frequency	2450 MHz ± 1 MHz	

Head TSL parameters

The following parameters and calculations were applied.

	Temperature	Permittivity	Conductivity
Nominal Head TSL parameters	22.0 °C	39.2	1.80 mho/m
Measured Head TSL parameters	(22.0 ± 0.2) °C	39.2 ± 6 %	1.78 mho/m ± 6 %
Head TSL temperature change during test	<1.0 °C	----	----

SAR result with Head TSL

SAR averaged over 1 cm³ (1 g) of Head TSL	Condition	
SAR measured	250 mW input power	13.0 W/kg
SAR for nominal Head TSL parameters	normalized to 1W	52.2 W/kg ± 18.8 % (k=2)
SAR averaged over 10 cm³ (10 g) of Head TSL	Condition	
SAR measured	250 mW input power	5.96 W/kg
SAR for nominal Head TSL parameters	normalized to 1W	23.9 W/kg ± 18.7 % (k=2)



Appendix (Additional assessments outside the scope of CNAS L0570)

Antenna Parameters with Head TSL

Impedance, transformed to feed point	54.4Ω+ 3.51jΩ
Return Loss	- 25.4dB

General Antenna Parameters and Design

Electrical Delay (one direction)	1.022 ns
----------------------------------	----------

After long term use with 100W radiated power, only a slight warming of the dipole near the feedpoint can be measured.

The dipole is made of standard semirigid coaxial cable. The center conductor of the feeding line is directly connected to the second arm of the dipole. The antenna is therefore short-circuited for DC-signals. On some of the dipoles, small end caps are added to the dipole arms in order to improve matching when loaded according to the position as explained in the "Measurement Conditions" paragraph. The SAR data are not affected by this change. The overall dipole length is still according to the Standard. No excessive force must be applied to the dipole arms, because they might bend or the soldered connections near the feedpoint may be damaged.

Additional EUT Data

Manufactured by	SPEAG
-----------------	-------



Add: No.51 Xueyuan Road, Haidian District, Beijing, 100191, China
Tel: +86-10-62304633-2079 Fax: +86-10-62304633-2504
E-mail: cttl@chinattl.com http://www.chinattl.cn

DASY5 Validation Report for Head TSL

Date: 11.10.2020

Test Laboratory: CTTL, Beijing, China

DUT: Dipole 2450 MHz; Type: D2450V2; Serial: D2450V2 - SN: 988

Communication System: UID 0, CW; Frequency: 2450 MHz; Duty Cycle: 1:1

Medium parameters used: $f = 2450$ MHz; $\sigma = 1.784$ S/m; $\epsilon_r = 39.22$; $\rho = 1000$ kg/m³

Phantom section: Center Section

DASY5 Configuration:

- Probe: EX3DV4 - SN3617; ConvF(7.65, 7.65, 7.65) @ 2450 MHz; Calibrated: 2020-01-30
- Sensor-Surface: 1.4mm (Mechanical Surface Detection)
- Electronics: DAE4 Sn771; Calibrated: 2020-02-10
- Phantom: MFP_V5.1C (20deg probe tilt); Type: QD 000 P51 Cx; Serial: 1062
- Measurement SW: DASY52, Version 52.10 (4); SEMCAD X Version 14.6.14 (7483)

Dipole Calibration/Zoom Scan (7x7x7) (7x7x7)/Cube 0: Measurement grid: dx=5mm, dy=5mm, dz=5mm

Reference Value = 106.2 V/m; Power Drift = -0.05 dB

Peak SAR (extrapolated) = 27.6 W/kg

SAR(1 g) = 13 W/kg; SAR(10 g) = 5.96 W/kg

Smallest distance from peaks to all points 3 dB below = 9 mm

Ratio of SAR at M2 to SAR at M1 = 47.1%

Maximum value of SAR (measured) = 22.2 W/kg

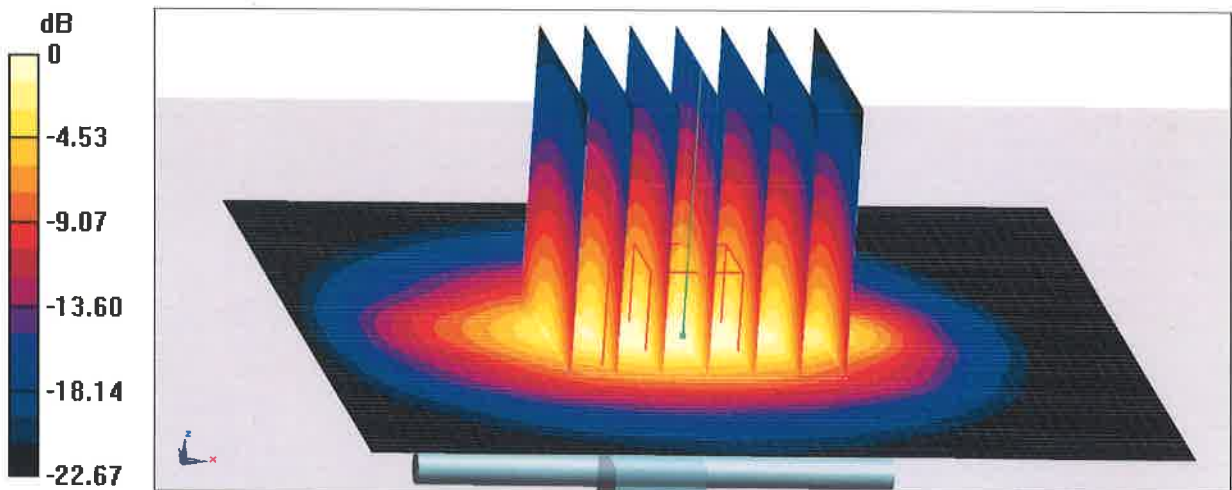

0 dB = 22.2 W/kg = 13.46 dBW/kg



Add: No.51 Xueyuan Road, Haidian District, Beijing, 100191, China
Tel: +86-10-62304633-2079 Fax: +86-10-62304633-2504
E-mail: cttl@chinattl.com http://www.chinattl.cn

Impedance Measurement Plot for Head TSL

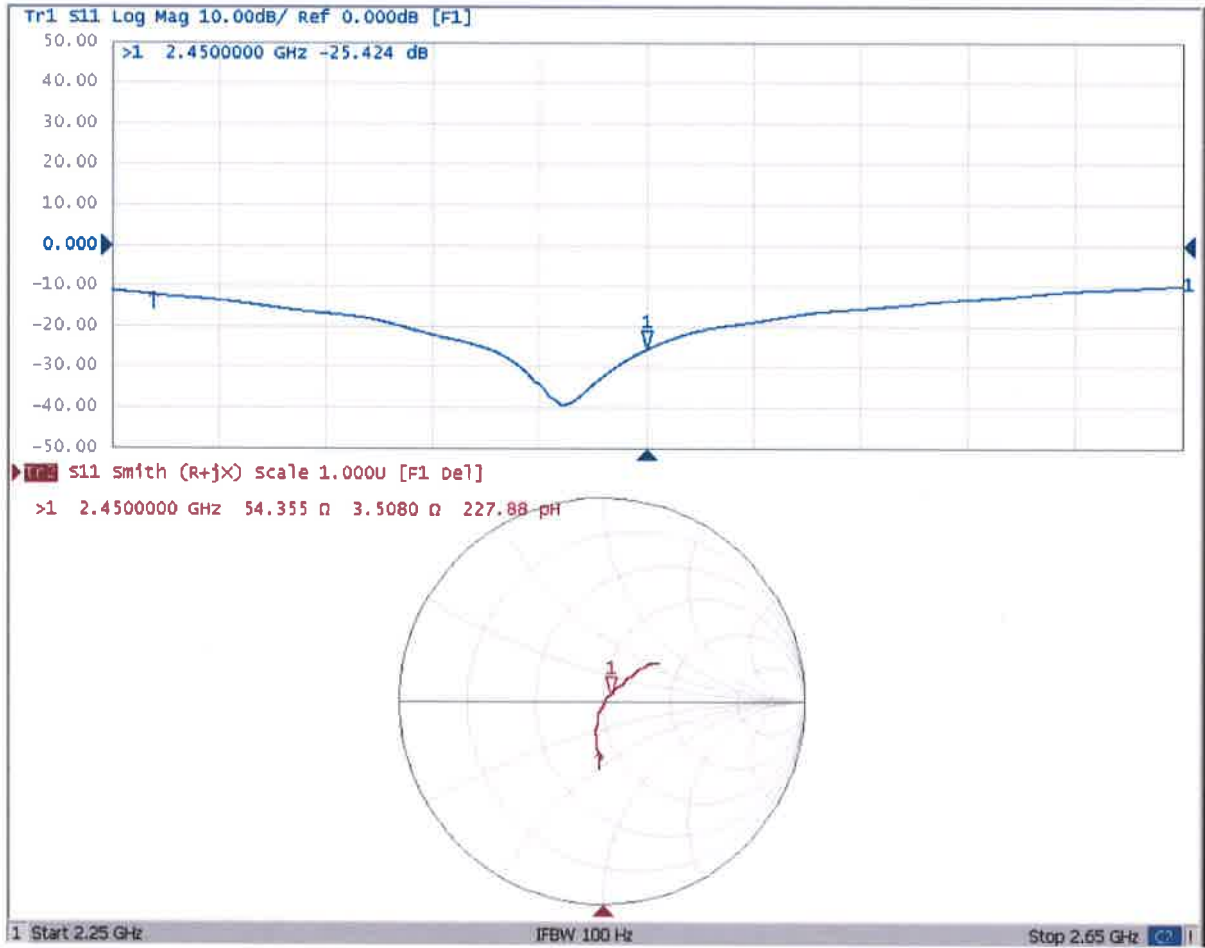



Accredited by the Swiss Accreditation Service (SAS)
The Swiss Accreditation Service is one of the signatories to the EA
Multilateral Agreement for the recognition of calibration certificates

Accreditation No.: **SCS 0108**

Client **Auden**

Certificate No: **DAE3-528_Jul21**

CALIBRATION CERTIFICATE

Object **DAE3 - SD 000 D03 AA - SN: 528**

Calibration procedure(s) **QA CAL-06.v30
Calibration procedure for the data acquisition electronics (DAE)**

Calibration date: **July 26, 2021**

This calibration certificate documents the traceability to national standards, which realize the physical units of measurements (SI).
The measurements and the uncertainties with confidence probability are given on the following pages and are part of the certificate.

All calibrations have been conducted in the closed laboratory facility: environment temperature (22 ± 3)°C and humidity < 70%.

Calibration Equipment used (M&TE critical for calibration)

Primary Standards	ID #	Cal Date (Certificate No.)	Scheduled Calibration
Keithley Multimeter Type 2001	SN: 0810278	07-Sep-20 (No:28647)	Sep-21
Secondary Standards	ID #	Check Date (in house)	Scheduled Check
Auto DAE Calibration Unit	SE UWS 053 AA 1001	07-Jan-21 (in house check)	In house check: Jan-22
Calibrator Box V2.1	SE UMS 006 AA 1002	07-Jan-21 (in house check)	In house check: Jan-22

Calibrated by: **Name** Adrian Gehring **Function** Laboratory Technician

Approved by: **Name** Sven Kühn **Deputy Manager**

Signature

Issued: July 26, 2021

This calibration certificate shall not be reproduced except in full without written approval of the laboratory.



Accredited by the Swiss Accreditation Service (SAS)

Accreditation No.: **SCS 0108**

The Swiss Accreditation Service is one of the signatories to the EA Multilateral Agreement for the recognition of calibration certificates

Glossary

DAE	data acquisition electronics
Connector angle	information used in DASY system to align probe sensor X to the robot coordinate system.

Methods Applied and Interpretation of Parameters

- *DC Voltage Measurement:* Calibration Factor assessed for use in DASY system by comparison with a calibrated instrument traceable to national standards. The figure given corresponds to the full scale range of the voltmeter in the respective range.
- *Connector angle:* The angle of the connector is assessed measuring the angle mechanically by a tool inserted. Uncertainty is not required.
- The following parameters as documented in the Appendix contain technical information as a result from the performance test and require no uncertainty.
 - *DC Voltage Measurement Linearity:* Verification of the Linearity at +10% and -10% of the nominal calibration voltage. Influence of offset voltage is included in this measurement.
 - *Common mode sensitivity:* Influence of a positive or negative common mode voltage on the differential measurement.
 - *Channel separation:* Influence of a voltage on the neighbor channels not subject to an input voltage.
 - *AD Converter Values with inputs shorted:* Values on the internal AD converter corresponding to zero input voltage
 - *Input Offset Measurement:* Output voltage and statistical results over a large number of zero voltage measurements.
 - *Input Offset Current:* Typical value for information; Maximum channel input offset current, not considering the input resistance.
 - *Input resistance:* Typical value for information: DAE input resistance at the connector, during internal auto-zeroing and during measurement.
 - *Low Battery Alarm Voltage:* Typical value for information. Below this voltage, a battery alarm signal is generated.
 - *Power consumption:* Typical value for information. Supply currents in various operating modes.

DC Voltage Measurement

A/D - Converter Resolution nominal

High Range: 1LSB = 6.1 μ V, full range = -100...+300 mV

Low Range: 1LSB = 61nV, full range = -1.....+3mV

DASY measurement parameters: Auto Zero Time: 3 sec; Measuring time: 3 sec

Calibration Factors	X	Y	Z
High Range	404.715 \pm 0.02% (k=2)	404.821 \pm 0.02% (k=2)	404.753 \pm 0.02% (k=2)
Low Range	3.97157 \pm 1.50% (k=2)	3.96014 \pm 1.50% (k=2)	3.96843 \pm 1.50% (k=2)

Connector Angle

Connector Angle to be used in DASY system	51.0 $^{\circ}$ \pm 1 $^{\circ}$
---	------------------------------------

Appendix (Additional assessments outside the scope of SCS0108)

1. DC Voltage Linearity

High Range	Reading (μV)	Difference (μV)	Error (%)
Channel X + Input	199996.41	2.36	0.00
Channel X + Input	20005.08	3.12	0.02
Channel X - Input	-19994.70	6.96	-0.03
Channel Y + Input	199995.60	1.69	0.00
Channel Y + Input	20002.40	0.42	0.00
Channel Y - Input	-20000.27	1.34	-0.01
Channel Z + Input	199996.30	1.81	0.00
Channel Z + Input	20000.97	-0.79	-0.00
Channel Z - Input	-19999.45	2.24	-0.01

Low Range	Reading (μV)	Difference (μV)	Error (%)
Channel X + Input	2001.32	0.25	0.01
Channel X + Input	201.90	0.37	0.18
Channel X - Input	-198.00	0.40	-0.20
Channel Y + Input	2001.10	0.10	0.01
Channel Y + Input	201.31	-0.03	-0.02
Channel Y - Input	-198.70	-0.28	0.14
Channel Z + Input	2001.11	0.05	0.00
Channel Z + Input	200.68	-0.67	-0.33
Channel Z - Input	-199.21	-0.63	0.32

2. Common mode sensitivity

DASY measurement parameters: Auto Zero Time: 3 sec; Measuring time: 3 sec

	Common mode Input Voltage (mV)	High Range Average Reading (μV)	Low Range Average Reading (μV)
Channel X	200	9.46	8.13
	- 200	-7.02	-8.71
Channel Y	200	15.42	15.28
	- 200	-16.36	-16.52
Channel Z	200	-3.94	-4.20
	- 200	2.96	2.87

3. Channel separation

DASY measurement parameters: Auto Zero Time: 3 sec; Measuring time: 3 sec

	Input Voltage (mV)	Channel X (μV)	Channel Y (μV)	Channel Z (μV)
Channel X	200	-	3.58	-2.25
Channel Y	200	6.49	-	4.82
Channel Z	200	7.16	5.79	-