



FCC 47 CFR PART 15 SUBPART E

TEST REPORT

For

802.11ac/b/g/n USB module

Model: WUBM-273ACN

Trade Name: SparkLAN

Issued to

SparkLAN Communications, Inc
8F., No.257, Sec. 2, Tiding Blvd., Neihu District, Taipei City 11493, Taiwan.

Issued by

Compliance Certification Services Inc.
No.11, Wugong 6th Rd., Wugu Dist.,
New Taipei City 24891, Taiwan. (R.O.C.)
<http://www.ccsrf.com>
service@ccsrf.com
Issued Date: January 7, 2015



Note: This report shall not be reproduced except in full, without the written approval of Compliance Certification Services Inc. This document may be altered or revised by Compliance Certification Services Inc. personnel only, and shall be noted in the revision section of the document.



Revision History

Rev.	Issue Date	Revisions	Effect Page	Revised By
00	January 7, 2015	Initial Issue	ALL	Kelly Cheng



TABLE OF CONTENTS

1. TEST RESULT CERTIFICATION.....	4
2. EUT DESCRIPTION	5
3. TEST METHODOLOGY	7
3.1 EUT CONFIGURATION.....	7
3.2 EUT EXERCISE	7
3.3 GENERAL TEST PROCEDURES	7
3.4 FCC PART 15.205 RESTRICTED BANDS OF OPERATIONS.....	8
3.5 DESCRIPTION OF TEST MODES.....	9
4. INSTRUMENT CALIBRATION.....	10
4.1 MEASURING INSTRUMENT CALIBRATION.....	10
4.2 MEASUREMENT EQUIPMENT USED	10
4.3 MEASUREMENT UNCERTAINTY	11
5. FACILITIES AND ACCREDITATIONS	12
5.1 FACILITIES	12
5.2 EQUIPMENT	12
5.3 TABLE OF ACCREDITATIONS AND LISTINGS	13
6. SETUP OF EQUIPMENT UNDER TEST	14
6.1 SETUP CONFIGURATION OF EUT	14
6.2 SUPPORT EQUIPMENT.....	14
7. FCC PART 15 REQUIREMENTS.....	15
7.1 26 DB EMISSION BANDWIDTH	15
7.2 AVERAGE POWER	33
7.3 BAND EDGES MEASUREMENT.....	36
7.4 PEAK POWER SPECTRAL DENSITY.....	53
7.5 RADIATED UNDESIRABLE EMISSION	71
7.6 POWERLINE CONDUCTED EMISSIONS	113
7.7 FREQUENCY STABILITY.....	118
APPENDIX I PHOTOGRAPHS OF TEST SETUP	128



1. TEST RESULT CERTIFICATION

Applicant: SparkLAN Communications, Inc
8F, No.150, Jian Yi Rd, Zhonghe District, New Taipei City,
235, Taiwan

Equipment Under Test: 802.11ac/b/g/n USB module

Trade Name: SparkLAN

Model: WUBM-273ACN

Date of Test: December 27, 2014 ~ January 5, 2015

APPLICABLE STANDARDS	
STANDARD	TEST RESULT
FCC 47 CFR Part 15 Subpart E	No non-compliance noted

We hereby certify that:

Compliance Certification Services Inc. tested the above equipment. The test data, data evaluation, test procedures, and equipment configurations shown in this report were made in accordance with the procedures given in ANSI C63.4: 2009 and the energy emitted by the sample EUT tested as described in this report is in compliance with conducted and radiated emission limits of FCC Rules Part 15.407.

The test results of this report relate only to the tested sample identified in this report.

Approved by:

Reviewed by:

Miller Lee
Section Manager
Compliance Certification Services Inc.

Angel Cheng
Section Manager
Compliance Certification Services Inc.



2. EUT DESCRIPTION

Product	802.11ac/b/g/n USB module			
Trade Name	SparkLAN			
Model Number	WUBM-273ACN			
Model Discrepancy	N/A			
Received Date	December 16, 2014			
Power Supply	Powered from host device			
Operating Frequency Range & Number of Channels	UNII Band I	Mode	Frequency Range (MHz)	Number of Channels
		IEEE 802.11a	5180 – 5240	4 Channels
		IEEE 802.11n HT 20 mode	5180 – 5240	4 Channels
		IEEE 802.11n HT 40 mode	5190 – 5230	2 Channels
	UNII Band IV	IEEE 802.11ac80 mode	5210	1 Channels
		IEEE 802.11a	5745 – 5825	5 Channels
		IEEE 802.11n HT 20 mode	5745 – 5825	5 Channels
		IEEE 802.11n HT 40 mode	5755 – 5795	2 Channels
IEEE 802.11ac80 mode	5775	1 Channels		
Transmit Power	IEEE 802.11a mode / 5180 ~ 5240MHz: 22.10dBm IEEE 802.11n HT 20 mode / 5180 ~ 5240MHz: 22.46dBm IEEE 802.11n HT 40 mode / 5190 ~ 5230MHz: 22.61dBm IEEE 802.11ac80 mode / 5210MHz: 22.87dBm IEEE 802.11a mode / 5745 ~ 5825MHz: 22.30dBm IEEE 802.11n HT 20 mode / 5745 ~ 5825MHz: 22.87dBm IEEE 802.11n HT 40 mode / 5755 ~ 5795MHz: 22.66dBm IEEE 802.11ac80 mode / 5775MHz: 22.87dBm			
Modulation Technique	OFDM (QPSK, BPSK, 16-QAM, 64-QAM)			
Transmit Data Rate	IEEE 802.11a mode: 54, 48, 36, 24, 18, 12, 9, 6 Mbps IEEE 802.11n HT 20 mode: OFDM (6.50, 13.00, 19.50, 26.00, 39.00, 52.00, 58.50, 65.00, 78.00, 104.0, 117.0, 130.0, 156.0, 175.5, 195.0Mbps) IEEE 802.11n HT 40 mode: OFDM (13.50, 27.00, 40.50, 54.00, 81.00, 108.0, 121.5, 135.0, 162.0, 216.0, 243.0, 270.0, 324.0, 364.5, 405.0Mbps) IEEE 802.11ac80 mode: OFDM (29.3, 58.5, 87.8, 117, 175.5, 234, 263.3, 292.5, 351, 390, 468, 526.5, 585, 702, 780 Mbps)			
Antenna Designation	1. SparkLAN / WUBM-273ACN printed Antenna / Gain: 1.68dBi MIMO: Total ANT=1.68+10*LOG(2)=4.68dBi (Numeric gain: 2.93) 2. LCT / DFE_ACBSMA-BGP Dipole Antenna / Gain: 5dBi MIMO: Total ANT=5+10*LOG(2)=8dBi (Numeric gain: 6.30)			



Operation Frequency

UNLICENSED NATIONAL INFORMATION INFRASTRUCTURE (U-NII)	
CHANNEL	MHz
36	5180
38	5190
40	5200
46	5230
48	5240
52	5260
54	5270
62	5310
64	5350
149	5745
153	5765
157	5785
161	5805
165	5825

Remark:

1. The sample selected for test was engineering sample that approximated to production product and was provided by manufacturer.
2. This submittal(s) (test report) is intended for FCC ID: **RYK-WUBM273ACN** filing to comply with Section 15.407 of the FCC Part 15, Subpart E Rules.
3. Client consigns two types to test (model number: WUBM-273ACN). Therefore, the testing Lab. just guarantees the unit, which has been tested.
4. There are four types for sale is just for marketing purpose only, please see as below:

Model	Type
WUBM-273ACN	12pin wafer connector + dipole antenna
	USB 3.0 type A + dipole antenna
	USB 3.0 type A + printed antenna
	12pin wafer connector + printed antenna



3. TEST METHODOLOGY

Both conducted and radiated testing was performed according to the procedures in ANSI C63.4. Radiated testing was performed at an antenna to EUT distance 3 meters.

3.1 EUT CONFIGURATION

The EUT configuration for testing is installed for RF field strength measurement to meet the Commissions requirement, and is operated in a manner intended to generate the maximum emission in a continuous normal application.

3.2 EUT EXERCISE

The EUT is operated in the engineering mode to fix the Tx frequency for the purposes of measurement.

According to its specifications, the EUT must comply with the requirements of Section 15.407 under the FCC Rules Part 15 Subpart E.

3.3 GENERAL TEST PROCEDURES

Conducted Emissions

The EUT is placed on the turntable, which is positioned at 0.8 m above the ground plane. According to the requirements in Section 13.1.4.1 of ANSI C63.4, the conducted emission from the EUT is measured in the frequency range between 0.15 MHz and 30MHz, using the CISPR Quasi-Peak detector mode.

Radiated Emissions

The EUT is placed on the turntable, which is 0.8 m above the ground plane. The turntable is then rotated for 360 degrees to determine the proper orientation for the maximum emission level. The EUT is set 3m away from the receiving antenna, which is varied from 1m to 4m to find out the highest emission level. And, each emission is to be maximized by changing the horizontal and vertical polarization of the receiving antenna. In order to find out the maximum emissions, exploratory radiated emission measurements were made according to the requirements in Section 13.1.4.1 of ANSI C63.4.



3.4 FCC PART 15.205 RESTRICTED BANDS OF OPERATIONS

(a) Except as shown in paragraph (d) of this section, only spurious emissions are permitted in any of the frequency bands listed below:

MHz	MHz	MHz	GHz
0.090 - 0.110	16.42 - 16.423	399.9 - 410	4.5 - 5.15
¹ 0.495 - 0.505	16.69475 - 16.69525	608 - 614	5.35 - 5.46
2.1735 - 2.1905	16.80425 - 16.80475	960 - 1240	7.25 - 7.75
4.125 - 4.128	25.5 - 25.67	1300 - 1427	8.025 - 8.5
4.17725 - 4.17775	37.5 - 38.25	1435 - 1626.5	9.0 - 9.2
4.20725 - 4.20775	73 - 74.6	1645.5 - 1646.5	9.3 - 9.5
6.215 - 6.218	74.8 - 75.2	1660 - 1710	10.6 - 12.7
6.26775 - 6.26825	108 - 121.94	1718.8 - 1722.2	13.25 - 13.4
6.31175 - 6.31225	123 - 138	2200 - 2300	14.47 - 14.5
8.291 - 8.294	149.9 - 150.05	2310 - 2390	15.35 - 16.2
8.362 - 8.366	156.52475 -	2483.5 - 2500	17.7 - 21.4
8.37625 - 8.38675	156.52525	2655 - 2900	22.01 - 23.12
8.41425 - 8.41475	156.7 - 156.9	3260 - 3267	23.6 - 24.0
12.29 - 12.293	162.0125 - 167.17	3332 - 3339	31.2 - 31.8
12.51975 - 12.52025	167.72 - 173.2	3345.8 - 3358	36.43 - 36.5
12.57675 - 12.57725	240 - 285	3600 - 4400	(²)
13.36 - 13.41	322 - 335.4		

¹ Until February 1, 1999, this restricted band shall be 0.490-0.510 MHz.

² Above 38.6

(b) Except as provided in paragraphs (d) and (e), the field strength of emissions appearing within these frequency bands shall not exceed the limits shown in Section 15.209. At frequencies equal to or less than 1000 MHz, compliance with the limits in Section 15.209 shall be demonstrated using measurement instrumentation employing a CISPR quasi-peak detector. Above 1000 MHz, compliance with the emission limits in Section 15.209 shall be demonstrated based on the average value of the measured emissions. The provisions in Section 15.35 apply to these measurements.



3.5 DESCRIPTION OF TEST MODES

The EUT had been tested under operating condition.

The EUT is a 2x2 configuration spatial MIMO (2Tx & 2Rx) without beam forming function that operate in double TX chains and double RX chains. The 2x2 configuration is implemented with two outside TX & RX chains (Chain 0 and 1).

Software used to control the EUT for staying in continuous transmitting mode was programmed.

After verification, all tests were carried out with the worst case test modes as shown below except radiated spurious emission below 1GHz and power line conducted emissions below 30MHz, which worst case was in normal link mode only.

UNII Band I:

IEEE 802.11a mode / 5180 ~ 5240MHz:

Channel Low (5180MHz), Channel Mid (5220MHz) and Channel High (5240MHz) with 6Mbps data rate were chosen for full testing.

IEEE 802.11n HT 20 mode / 5180 ~ 5240MHz:

Channel Low (5180MHz), Channel Mid (5220MHz) and Channel High (5240MHz) with 6Mbps data rate were chosen for full testing.

IEEE 802.11n HT 40 mode / 5190 ~ 5230MHz:

Channel Low (5190MHz) and Channel High (5230MHz) with 13.5Mbps data rate were chosen for full testing.

IEEE 802.11n HT 80 MHz Channel for 5210MHz:

Channel Low(5210MHz) with 29.3Mbps data rate were chosen for full testing.

UNII Band VI:

IEEE 802.11a mode:

Channel Low (5745MHz), Channel Mid (5785MHz) and Channel High (5825MHz) with 6Mbps data rate were chosen for full testing.

IEEE 802.11n HT 20 mode:

Channel Low(5745MHz), Channel Mid(5785MHz) and Channel High(5825MHz) with 6.5Mbps data rate were chosen for full testing.

IEEE 802.11n HT 40 mode:

Channel Low(5755MHz) and Channel High(5795MHz) with 13.5Mbps data rate were chosen for full testing.

IEEE 802.11ac80 mode:

Channel Low(5775MHz) with 29.3Mbps data rate were chosen for full testing.



4. INSTRUMENT CALIBRATION

4.1 MEASURING INSTRUMENT CALIBRATION

The measuring equipment, which was utilized in performing the tests documented herein, has been calibrated in accordance with the manufacturer's recommendations for utilizing calibration equipment, which is traceable to recognized national standards.

4.2 MEASUREMENT EQUIPMENT USED

Equipment Used for Emissions Measurement

Remark: Each piece of equipment is scheduled for calibration once a year and Loop Antenna is scheduled for calibration once three years.

Conducted Emissions Test Site				
Name of Equipment	Manufacturer	Model	Serial Number	Calibration Due
Spectrum Analyzer	Agilent	E4446A	MY43360131	03/26/2015
Power Meter	Anritsu	ML2495A	1012009	06/03/2015
Power Sensor	Anritsu	MA2411A	0917072	06/03/2015

3M Chamber Test Site				
Name of Equipment	Manufacturer	Model	Serial Number	Calibration Due
Spectrum Analyzer	Agilent	E4446A	US42510268	11/04/2015
EMI Test Receiver	R&S	ESCI	100064	02/16/2015
Pre-Amplifier	Mini-Circuits	ZFL-1000LN	SF350700823	01/11/2015
Pre-Amplifier	MITEQ	AFS44-00102650-42-10P-44	1415367	11/17/2015
Bilog Antenna	Sunol Sciences	JB3	A030105	09/30/2015
Horn Antenna	EMCO	3117	00055165	02/16/2015
Horn Antenna	EMCO	3116	2487	10/08/2015
Loop Antenna	EMCO	6502	8905/2356	06/11/2015
Turn Table	CCS	CC-T-1F	N/A	N.C.R
Antenna Tower	CCS	CC-A-1F	N/A	N.C.R
Controller	CCS	CC-C-1F	N/A	N.C.R
Site NSA	CCS	N/A	N/A	12/20/2015
Test S/W	EZ-EMC (CCS-3A1RE)			

Conducted Emission room # A				
Name of Equipment	Manufacturer	Model	Serial Number	Calibration Due
EMI Test Receiver	R&S	ESI	101203	09/11/2015
LISN	R&S	ESH3-Z5	848773/014	12/04/2015
Coaxial Cable	Commate	CFD300-NL	NA	12/04/2015
Test S/W	CCS-3A1-CE			



4.3 MEASUREMENT UNCERTAINTY

PARAMETER	UNCERTAINTY
Powerline Conducted Emission	+/- 1.2159
3M Semi Anechoic Chamber / <200M	+/- 4.0138
3M Semi Anechoic Chamber / 200M~1000M	+/- 3.9483
3M Semi Anechoic Chamber / 1G~8G	+/- 2.5975
3M Semi Anechoic Chamber / 8G~18G	+/- 2.6112
3M Semi Anechoic Chamber / 18G~26G	+/- 2.7389
3M Semi Anechoic Chamber / 26G~40G	+/- 2.9683

Remark: This uncertainty represents an expanded uncertainty expressed at approximately the 95% confidence level using a coverage factor of $k=2$.



5. FACILITIES AND ACCREDITATIONS

5.1 FACILITIES

All measurement facilities used to collect the measurement data are located at

No.199, Chungshen Road, Hsintien City, Taipei Hsien, Taiwan, R.O.C.

Tel: 886-2-2217-0894 / Fax: 886-2-2217-1029

No.11, Wugong 6th Rd., Wugu Dist., New Taipei City 24891, Taiwan. (R.O.C.)

Tel: 886-2-2299-9720 / Fax: 886-2-2298-4045

No.81-1, Lane 210, Bade 2nd Rd., Lujhu Township, Taoyuan County 33841, TAIWAN, R.O.C.

Tel: 886-3-324-0332 / Fax: 886-3-324-5235

The sites are constructed in conformance with the requirements of ANSI C63.7, ANSI C63.4 and CISPR Publication 22.

5.2 EQUIPMENT

Radiated emissions are measured with one or more of the following types of linearly polarized antennas: tuned dipole, biconical, log periodic, bi-log, and/or ridged waveguide, horn. Spectrum analyzers with pre-selectors and quasi-peak detectors are used to perform radiated measurements.



Conducted emissions are measured with Line Impedance Stabilization Networks and EMI Test Receivers.

Calibrated wideband preamplifiers, coaxial cables, and coaxial attenuators are also used for making measurements.

All receiving equipment conforms to CISPR Publication 16-1, "Radio Interference Measuring Apparatus and Measurement Methods."



5.3 TABLE OF ACCREDITATIONS AND LISTINGS

Country	Agency	Scope of Accreditation	Logo
USA	FCC	3M Semi Anechoic Chamber (FCC MRA: TW1039) to perform FCC Part 15 measurements	 FCC MRA: TW1039
Taiwan	TAF	LP0002, RTTE01, FCC Method-47 CFR Part 15 Subpart C, D, E, RSS-210, RSS-310 IDA TS SRD, AS/NZS 4268, AS/NZS 4771, TS 12.1 & 12.2, ETSI EN 300 440-1, ETSI EN 300 440-2, ETSI EN 300 328, ETSI EN 300 220-1, ETSI EN 300 220-2, ETSI EN 301 893, ETSI EN 301 489-1/3/7/17 FCC OET Bulletin 65 + Supplement C, EN 50360, EN 50361, EN 50371, RSS 102, EN 50383, EN 50385, EN 50392, IEC 62209, CNS 14958-1, CNS 14959 FCC Method -47 CFR Part 15 Subpart B IEC / EN 61000-3-2, IEC / EN 61000-3-3, IEC / EN 61000-4-2/3/4/5/6/8/11	
Canada	Industry Canada	3M Semi Anechoic Chamber (IC 2324G-1 / IC 2324G-2) to perform	

* No part of this report may be used to claim or imply product endorsement by A2LA or any agency of the US Government.



6. SETUP OF EQUIPMENT UNDER TEST

6.1 SETUP CONFIGURATION OF EUT

See test photographs attached in Appendix II for the actual connections between EUT and support equipment.

6.2 SUPPORT EQUIPMENT

No	Equipment	Brand	Model	Series No.	FCC ID	Data Cable	Power Cord
1	Notebook PC	DELL	PP19L	7B3ZP1S	N/A	N/A	AC I/P: Unshielded, 1.8m DC O/P: Unshielded, 1.8m with a core

Remark:

1. All the equipment/cables were placed in the worst-case configuration to maximize the emission during the test.
2. Grounding was established in accordance with the manufacturer's requirements and conditions for the intended use.



7. FCC PART 15 REQUIREMENTS

7.1 26 DB EMISSION BANDWIDTH

LIMIT

According to §15.303(c), for purposes of this subpart the emission bandwidth shall be determined by measuring the width of the signal between two points, one below the carrier center frequency and one above the carrier center frequency, that are 26 dB down relative to the maximum level of the modulated carrier. Compliance with the emissions limits is based on the use of measurement instrumentation employing a peak detector function with an instrument resolutions bandwidth approximately equal to 1.0 percent of the emission bandwidth of the device under measurement.

Test Configuration

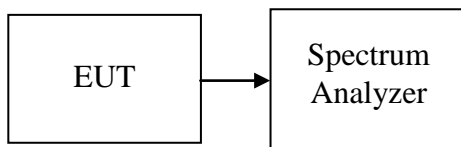

TEST PROCEDURE

1. Place the EUT on the table and set it in the transmitting mode.
2. Remove the antenna from the EUT and then connect a low-loss RF cable from the antenna port to the spectrum analyzer.
3. Set the spectrum analyzer as $RBW = 1\%EBW$, $VBW = RBW$, $Span = 50MHz$, and $Sweep = auto$.
Or Set the spectrum analyzer as $RBW > 1\%EBW$, $VBW > RBW$, $Span > 26dB$ bandwidth, and $Sweep = auto$.
4. Mark the peak frequency and $-26dB$ (upper and lower) frequency.
5. Repeat until all the rest channels were investigated.



TEST RESULTS

No non-compliance noted

Test Data

Test mode: IEEE 802.11a mode / 5180 ~ 5240MHz

Channel	Frequency (MHz)	Bandwidth (MHz)
Low	5180	32.854
Mid	5220	34.763
High	5240	31.148

Test mode: IEEE 802.11n HT 20 mode / 5180 ~ 5240MHz / Chain 0

Channel	Frequency (MHz)	Bandwidth (MHz)
Low	5180	32.760
Mid	5220	29.638
High	5240	30.743

Test mode: IEEE 802.11n HT 20 mode / 5180 ~ 5240MHz / Chain 1

Channel	Frequency (MHz)	Bandwidth (MHz)
Low	5180	31.417
Mid	5220	30.351
High	5240	22.896

Test mode: IEEE 802.11n HT 40 mode / 5190 ~ 5230MHz / Chain 0

Channel	Frequency (MHz)	Bandwidth (MHz)
Low	5190	41.484
High	5230	49.404

Test mode: IEEE 802.11n HT 40 mode/ 5190 ~ 5230MHz / Chain 1

Channel	Frequency (MHz)	Bandwidth (MHz)
Low	5190	41.286
High	5230	41.553

Test mode: IEEE 802.11ac80 mode / 5210MHz / Chain 0

Channel	Frequency (MHz)	Bandwidth (B) (MHz)
Mid	5210	81.259

Test mode: IEEE 802.11ac80 mode/ 5210MHz / Chain 1

Channel	Frequency (MHz)	Bandwidth (B) (MHz)
Mid	5210	81.086



Test mode: IEEE 802.11a mode / 5745 ~ 5825MHz

Channel	Frequency (MHz)	Bandwidth (MHz)
Low	5745	16.621
Mid	5785	16.549
High	5825	16.498

Test mode: IEEE 802.11n HT 20 mode / 5745 ~ 5825MHz / Chain 0

Channel	Frequency (MHz)	Bandwidth (MHz)
Low	5745	17.526
Mid	5785	17.511
High	5825	17.174

Test mode: IEEE 802.11n HT 20 mode / 5745 ~ 5825MHz / Chain 1

Channel	Frequency (MHz)	Bandwidth (MHz)
Low	5745	17.199
Mid	5785	16.875
High	5825	17.486

Test mode: IEEE 802.11n HT 40 mode / 5755 ~ 5795MHz / Chain 0

Channel	Frequency (MHz)	Bandwidth (MHz)
Low	5755	36.362
High	5795	36.075

Test mode: IEEE 802.11n HT 40 mode / 5755 ~ 5795MHz / Chain 1

Channel	Frequency (MHz)	Bandwidth (MHz)
Low	5755	35.763
High	5795	35.895

Test mode: IEEE 802.11ac80 mode / 5775MHz / Chain 0

Channel	Frequency (MHz)	Bandwidth (B) (MHz)
Mid	5290	74.471

Test mode: IEEE 802.11ac80 mode / 5775MHz / Chain 1

Channel	Frequency (MHz)	Bandwidth (B) (MHz)
Mid	5290	74.360



Test Plot

IEEE 802.11a mode / 5180 ~ 5240MHz

CH Low

Agilent

R T

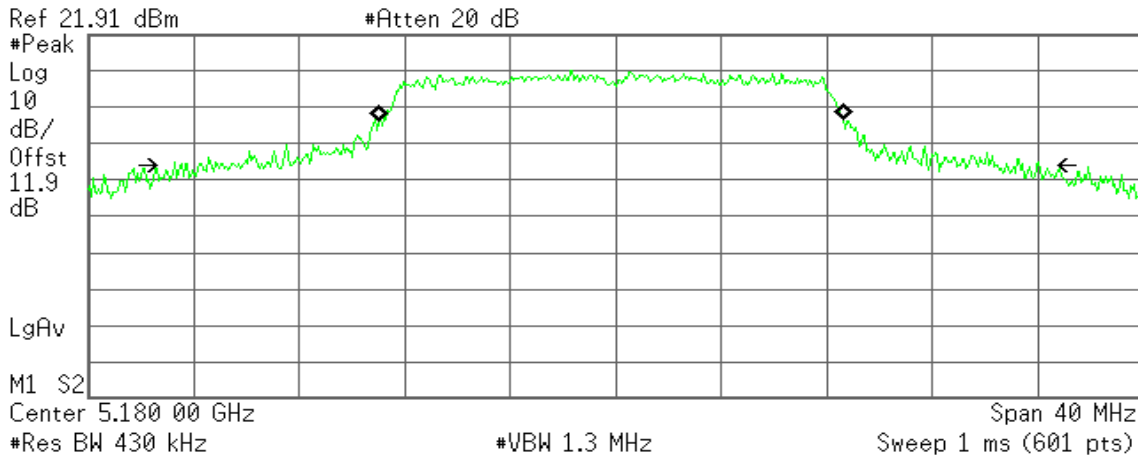

Occupied Bandwidth

17.6486 MHz

Occ BW % Pwr 99.00 %
x dB -26.00 dB

Transmit Freq Error -145.668 kHz
x dB Bandwidth 32.854 MHz

CH Mid

Agilent

R T

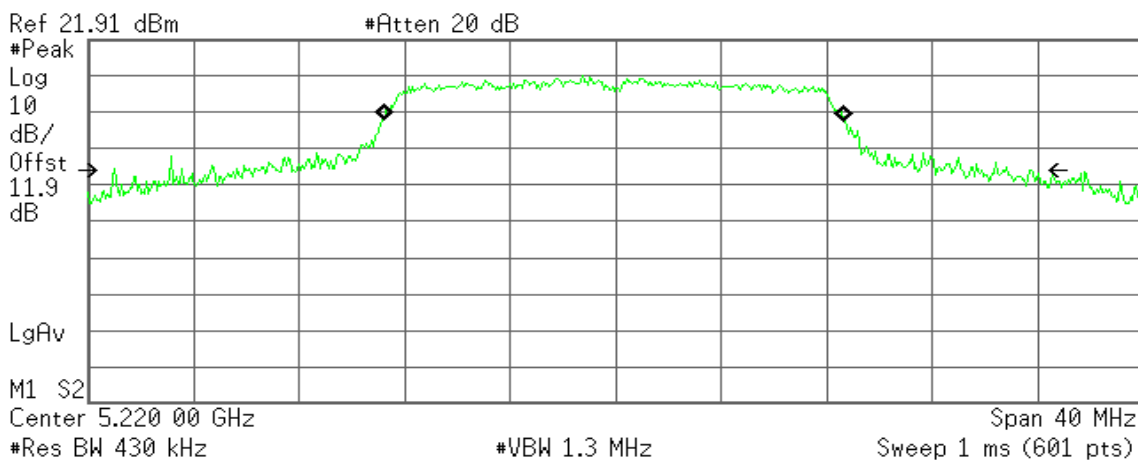

Occupied Bandwidth

17.4761 MHz

Occ BW % Pwr 99.00 %
x dB -26.00 dB

Transmit Freq Error -64.487 kHz
x dB Bandwidth 34.763 MHz



CH High

Agilent

R T

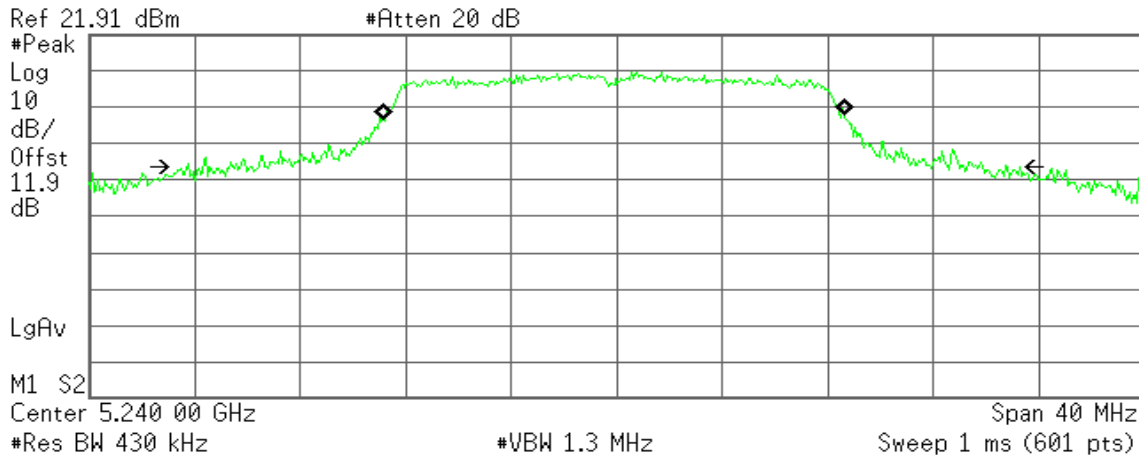

Occupied Bandwidth
17.5375 MHz

Occ BW % Pwr 99.00 %
x dB -26.00 dB

Transmit Freq Error -121.816 kHz
x dB Bandwidth 31.148 MHz

IEEE 802.11n HT 20 mode / 5180 ~ 5240MHz / Chain 0

CH Low

Agilent

R T

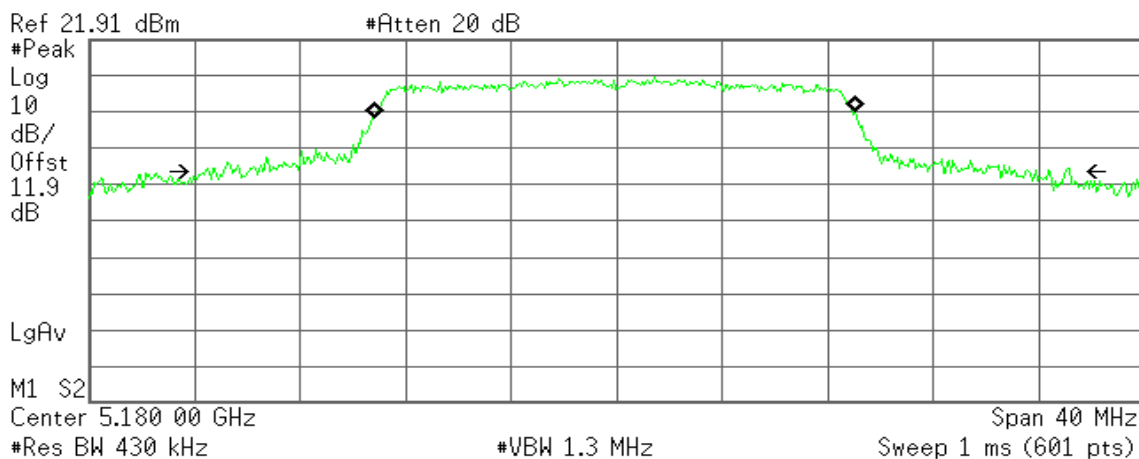

Occupied Bandwidth
18.2952 MHz

Occ BW % Pwr 99.00 %
x dB -26.00 dB

Transmit Freq Error -83.805 kHz
x dB Bandwidth 32.760 MHz



CH Mid

Agilent

R T

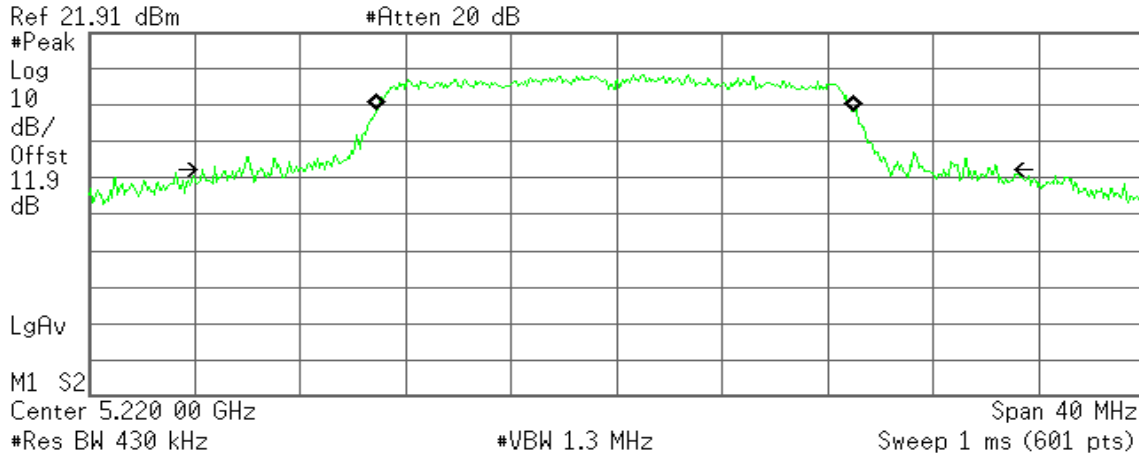

Occupied Bandwidth
18.0767 MHz

Occ BW % Pwr 99.00 %
x dB -26.00 dB

Transmit Freq Error -62.192 kHz
x dB Bandwidth 29.638 MHz

CH High

Agilent

R T

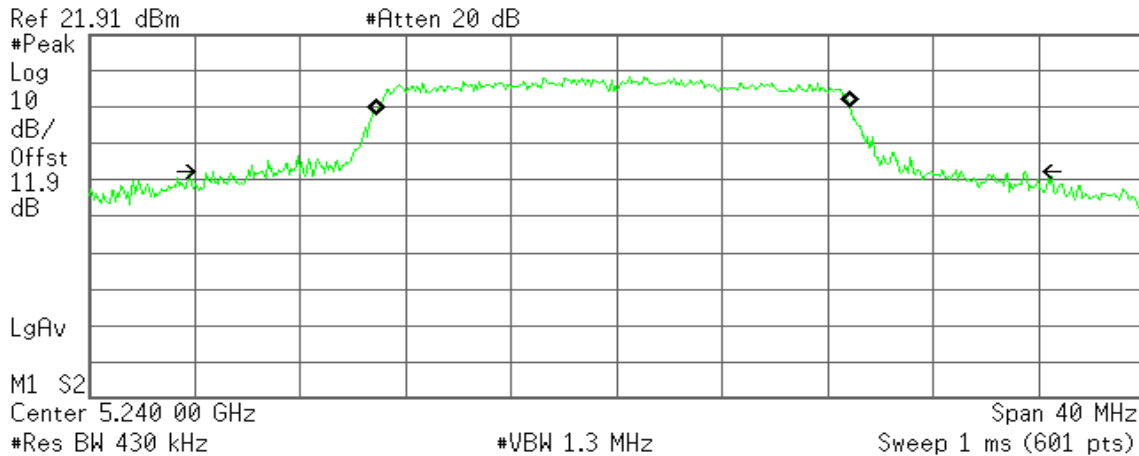

Occupied Bandwidth
18.0325 MHz

Occ BW % Pwr 99.00 %
x dB -26.00 dB

Transmit Freq Error -127.355 kHz
x dB Bandwidth 30.743 MHz



IEEE 802.11n HT 20 mode / 5180 ~ 5240MHz / Chain 1

CH Low

Agilent

R T

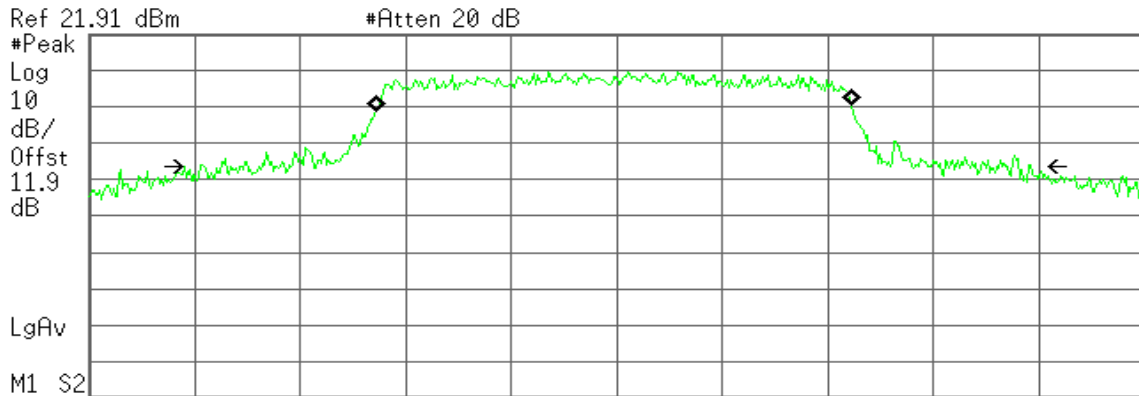

Occupied Bandwidth

18.0487 MHz

Occ BW % Pwr 99.00 %
x dB -26.00 dB

Transmit Freq Error -96.802 kHz
x dB Bandwidth 31.417 MHz

CH Mid

Agilent

R T

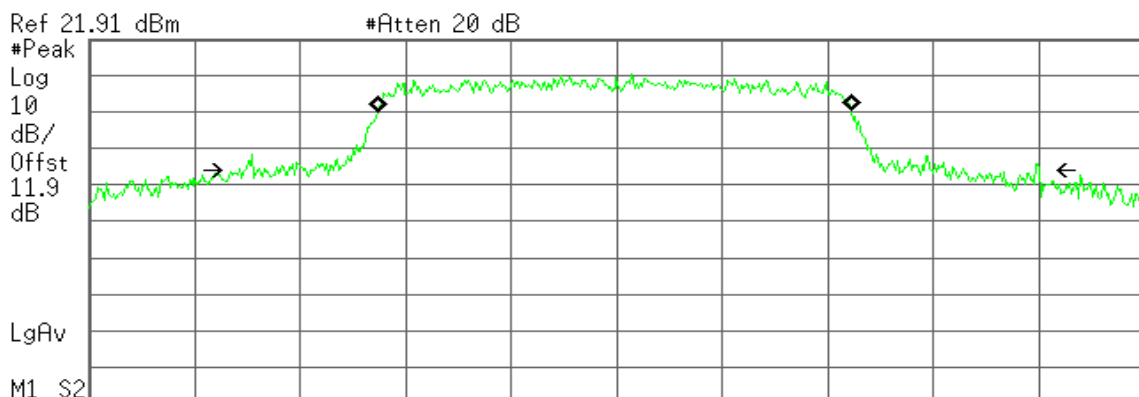

Occupied Bandwidth

17.9870 MHz

Occ BW % Pwr 99.00 %
x dB -26.00 dB

Transmit Freq Error -81.444 kHz
x dB Bandwidth 30.351 MHz



CH High

Agilent

R T

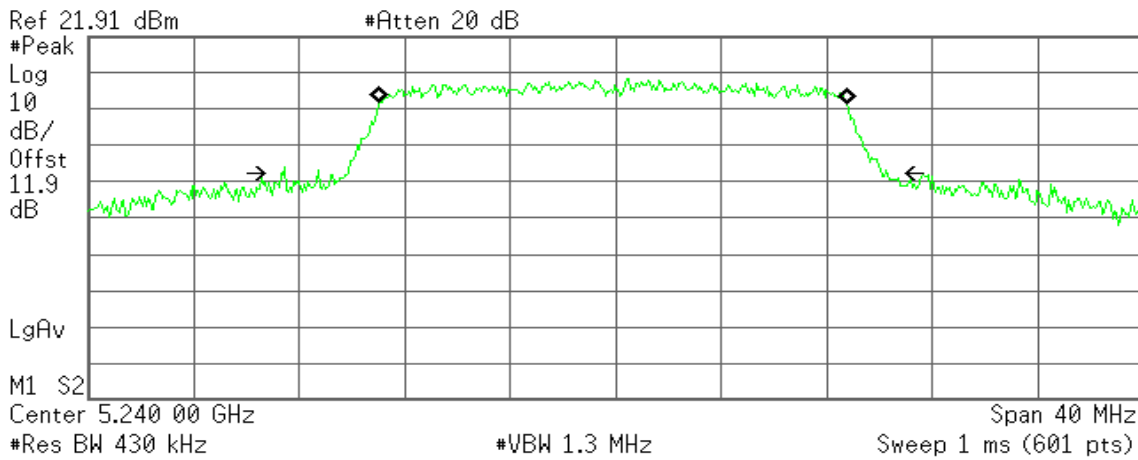

Occupied Bandwidth
17.8234 MHz

Occ BW % Pwr 99.00 %
x dB -26.00 dB

Transmit Freq Error -96.616 kHz
x dB Bandwidth 22.896 MHz

IEEE 802.11n HT 40 mode / 5190 ~ 5230MHz / Chain 0

CH Low

Agilent

R T

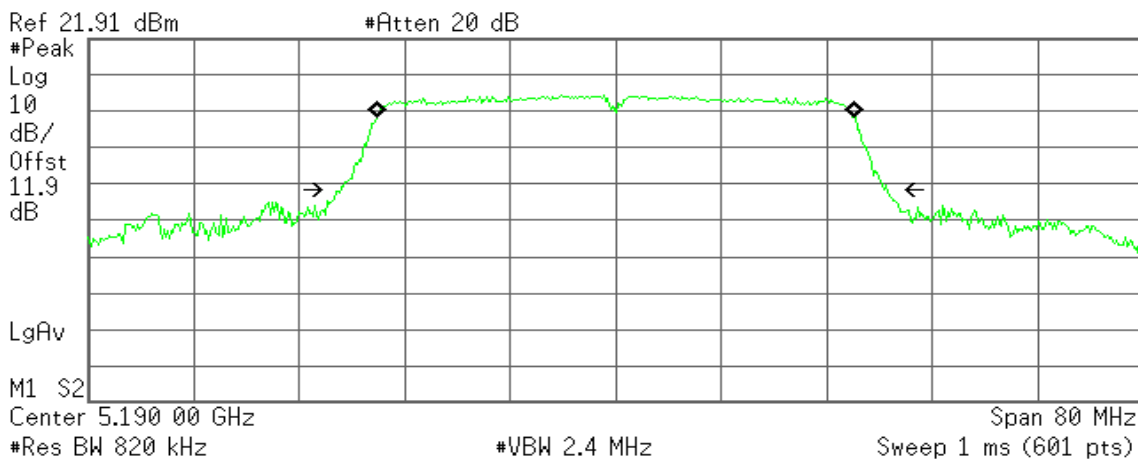

Occupied Bandwidth
36.2177 MHz

Occ BW % Pwr 99.00 %
x dB -26.00 dB

Transmit Freq Error -41.989 kHz
x dB Bandwidth 41.484 MHz



CH High

Agilent

R T

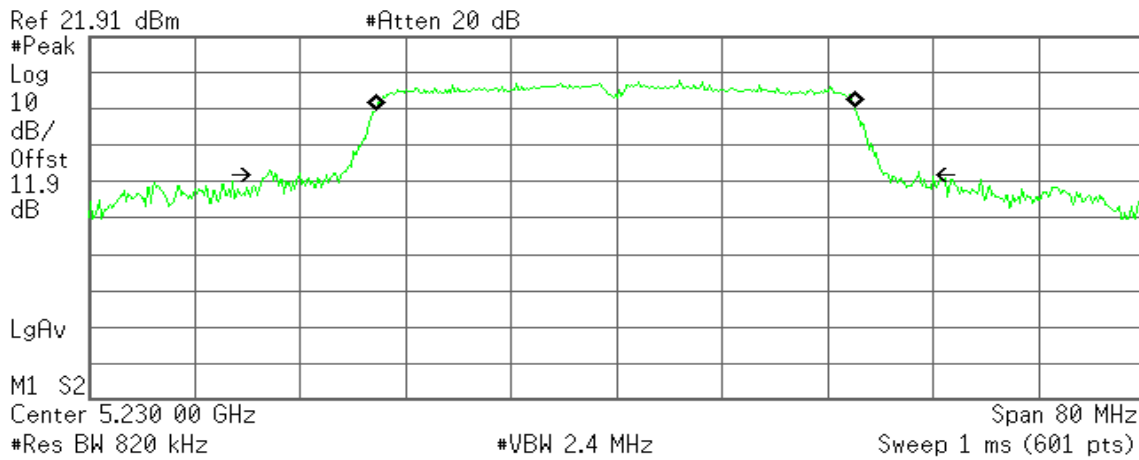

Occupied Bandwidth
36.4061 MHz

Occ BW % Pwr 99.00 %
x dB -26.00 dB

Transmit Freq Error -119.493 kHz
x dB Bandwidth 49.404 MHz

IEEE 802.11n HT 40 mode / 5190 ~ 5230MHz / Chain 1

CH Low

Agilent

R T

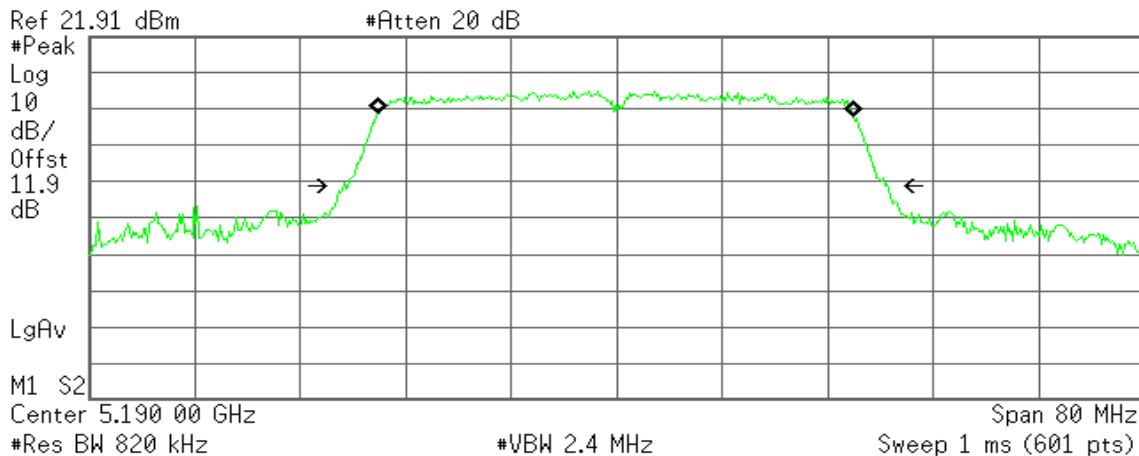

Occupied Bandwidth
36.1746 MHz

Occ BW % Pwr 99.00 %
x dB -26.00 dB

Transmit Freq Error -83.488 kHz
x dB Bandwidth 41.286 MHz



CH High

Agilent

R T

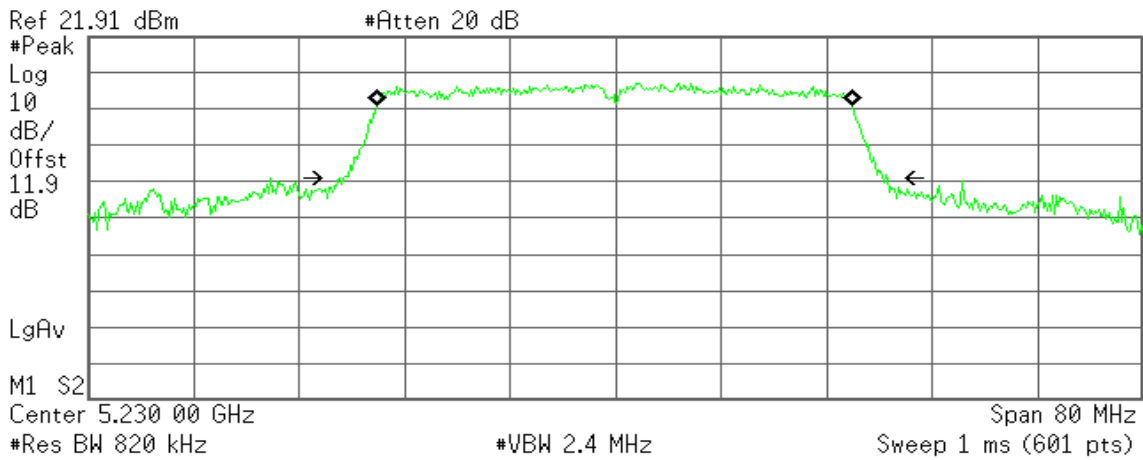

Occupied Bandwidth
36.1130 MHz

Occ BW % Pwr 99.00 %
x dB -26.00 dB

Transmit Freq Error -106.708 kHz
x dB Bandwidth 41.553 MHz

IEEE 802.11ac80 mode / 5210MHz / Chain 0

Agilent

R T

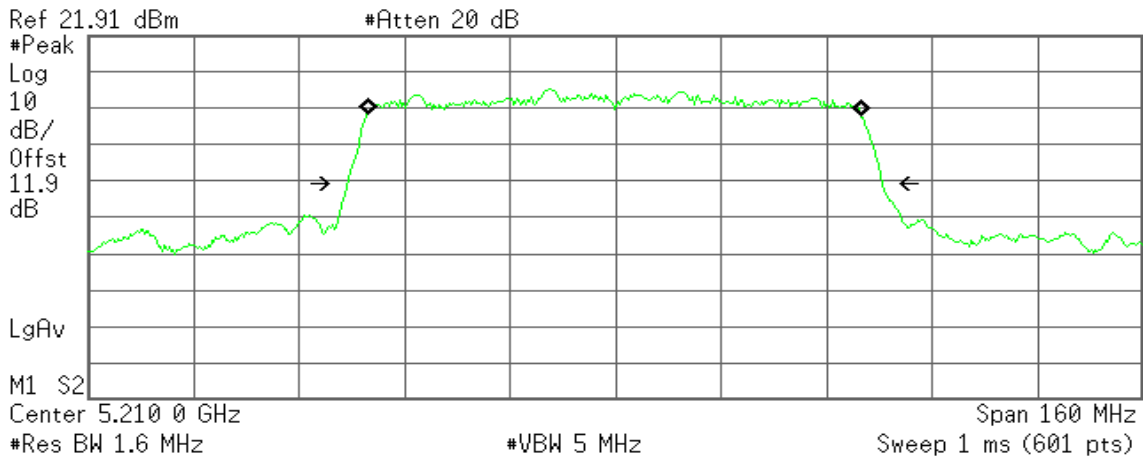

Occupied Bandwidth
74.8894 MHz

Occ BW % Pwr 99.00 %
x dB -26.00 dB

Transmit Freq Error -158.030 kHz
x dB Bandwidth 81.259 MHz



IEEE 802.11ac80 mode / 5210MHz / Chain 1

Agilent

R T

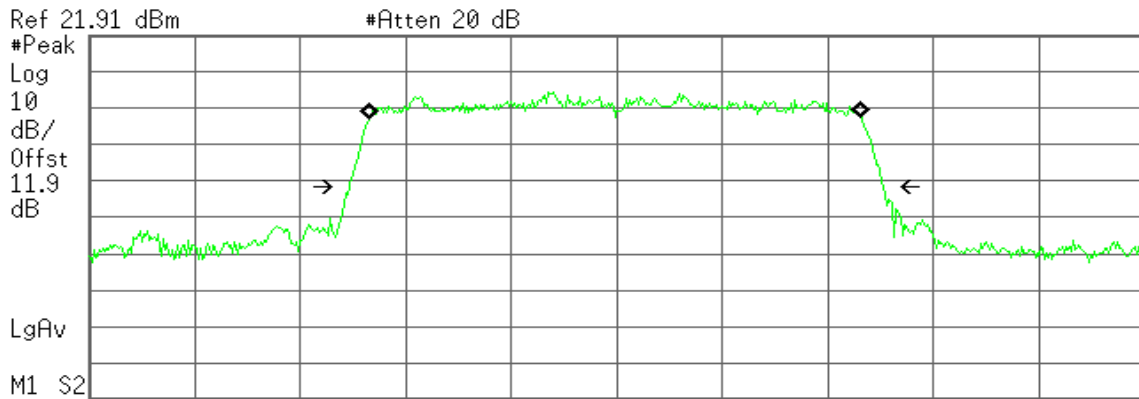

Center 5.210 0 GHz Span 160 MHz
 #Res BW 1.6 MHz #VBW 5 MHz Sweep 1 ms (601 pts)

Occupied Bandwidth
74.6837 MHz

Occ BW % Pwr 99.00 %
x dB -26.00 dB

Transmit Freq Error -171.445 kHz
x dB Bandwidth 81.086 MHz

IEEE 802.11a mode / 5745 ~ 5825MHz

CH Low

Agilent

R T

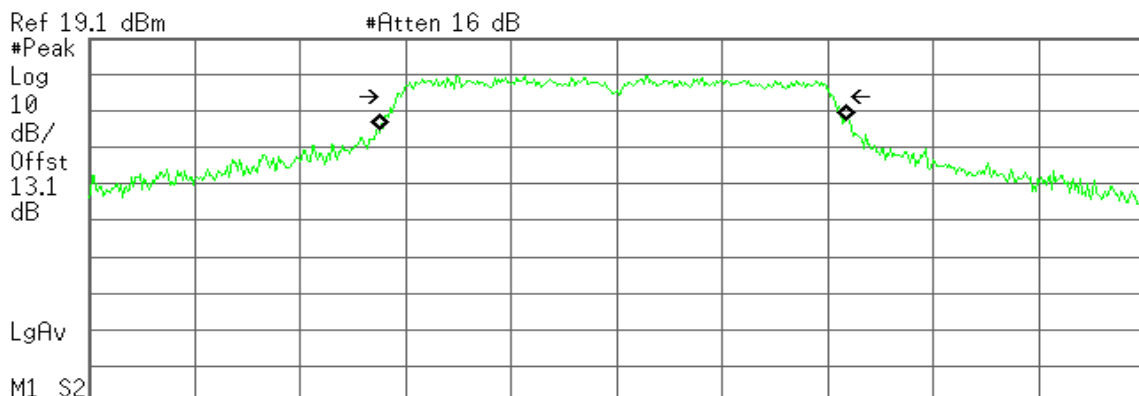

Center 5.745 00 GHz Span 40 MHz
 #Res BW 430 kHz #VBW 1.3 MHz Sweep 1 ms (601 pts)

Occupied Bandwidth
17.7239 MHz

Occ BW % Pwr 99.00 %
x dB -6.00 dB

Transmit Freq Error -110.348 kHz
x dB Bandwidth 16.621 MHz



CH Mid

Agilent

R T

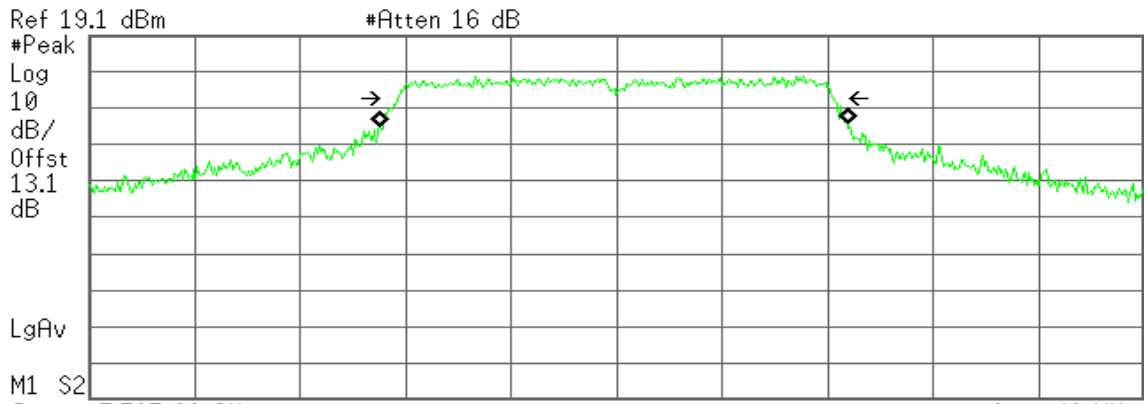

Occupied Bandwidth
17.7974 MHz

Occ BW % Pwr 99.00 %
x dB -6.00 dB

Transmit Freq Error -125.531 kHz
x dB Bandwidth 16.549 MHz

CH High

Agilent

R T

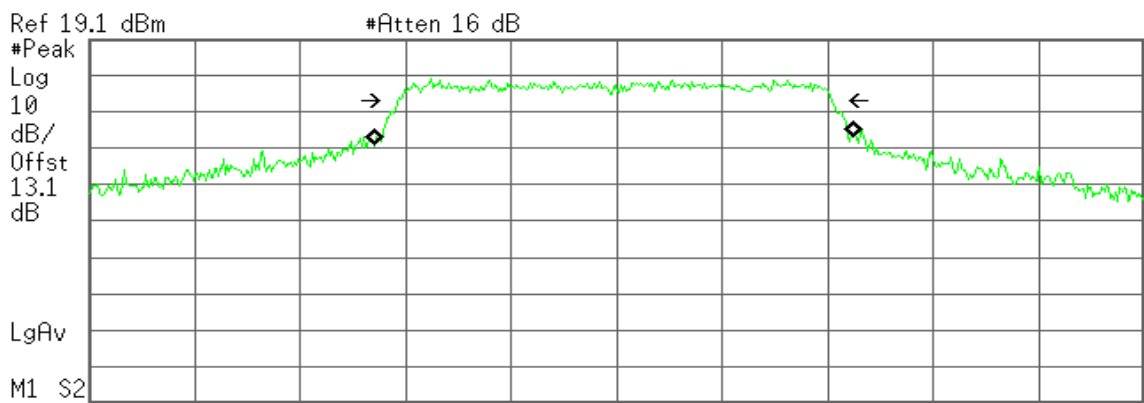

Occupied Bandwidth
18.2464 MHz

Occ BW % Pwr 99.00 %
x dB -6.00 dB

Transmit Freq Error -103.782 kHz
x dB Bandwidth 16.498 MHz



IEEE 802.11n HT 20 mode / 5745 ~ 5825MHz / Chain 0

CH Low

Agilent

R T

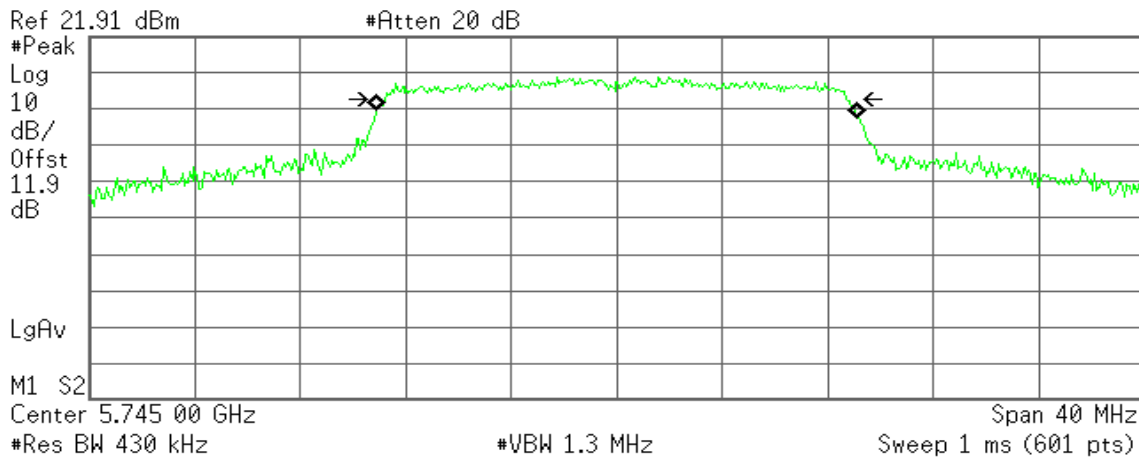

Occupied Bandwidth

18.2453 MHz

Occ BW % Pwr 99.00 %
x dB -6.00 dB

Transmit Freq Error 9.986 kHz
x dB Bandwidth 17.526 MHz

CH Mid

Agilent

R T

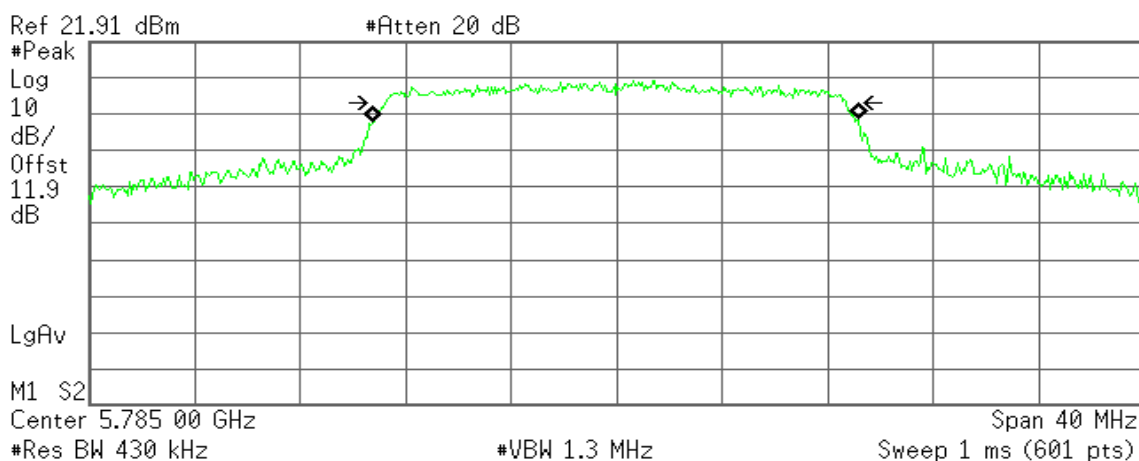

Occupied Bandwidth

18.4184 MHz

Occ BW % Pwr 99.00 %
x dB -6.00 dB

Transmit Freq Error -37.499 kHz
x dB Bandwidth 17.511 MHz



CH High

Agilent

R T

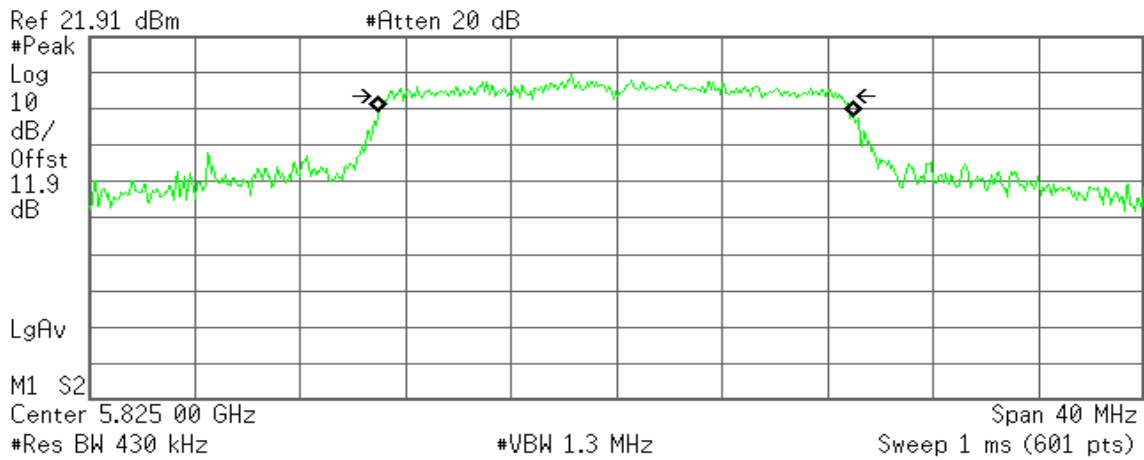

Occupied Bandwidth

18.0218 MHz

Occ BW % Pwr	99.00 %
x dB	-6.00 dB

Transmit Freq Error	-26.162 kHz
x dB Bandwidth	17.174 MHz

IEEE 802.11n HT 20 mode / 5745 ~ 5825MHz / Chain 1

CH Low

Agilent

R T

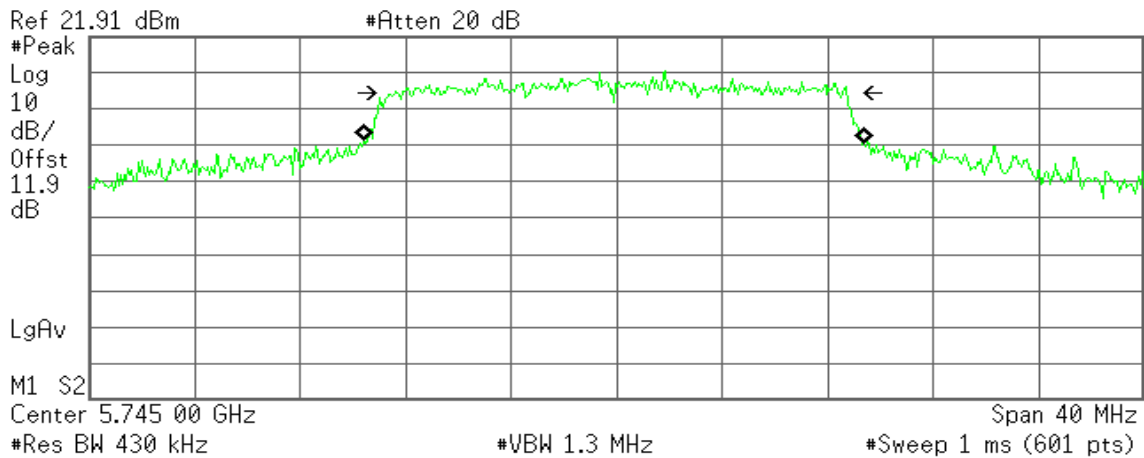

Occupied Bandwidth

19.0206 MHz

Occ BW % Pwr	99.00 %
x dB	-6.00 dB

Transmit Freq Error	-82.629 kHz
x dB Bandwidth	17.199 MHz



CH Mid

Agilent

R T

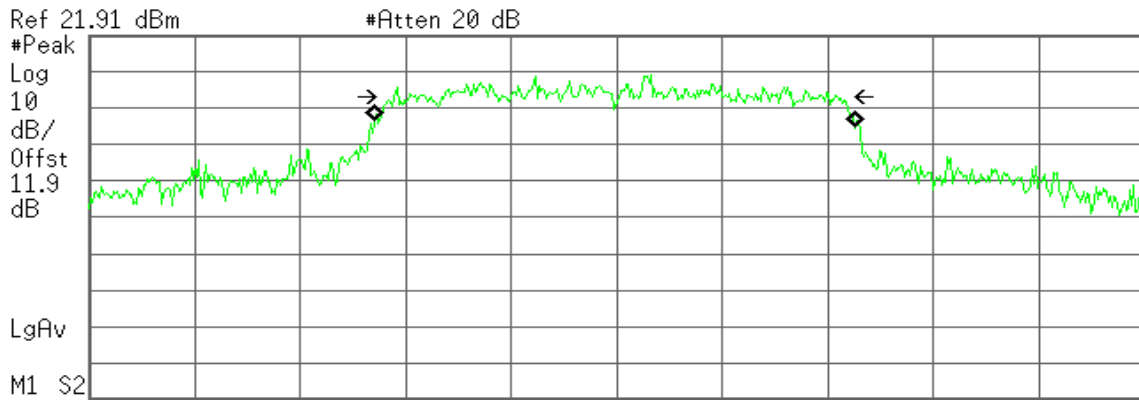

Ref 21.91 dBm #Atten 20 dB
#Peak
Log
10
dB/
Offst
11.9
dB
LgAv
M1 S2
Center 5.785 00 GHz Span 40 MHz
#Res BW 430 kHz #VBW 1.3 MHz Sweep 1 ms (601 pts)

Occupied Bandwidth
18.2543 MHz

Occ BW % Pwr 99.00 %
x dB -6.00 dB

Transmit Freq Error -70.484 kHz
x dB Bandwidth 16.875 MHz

CH High

Agilent

R T

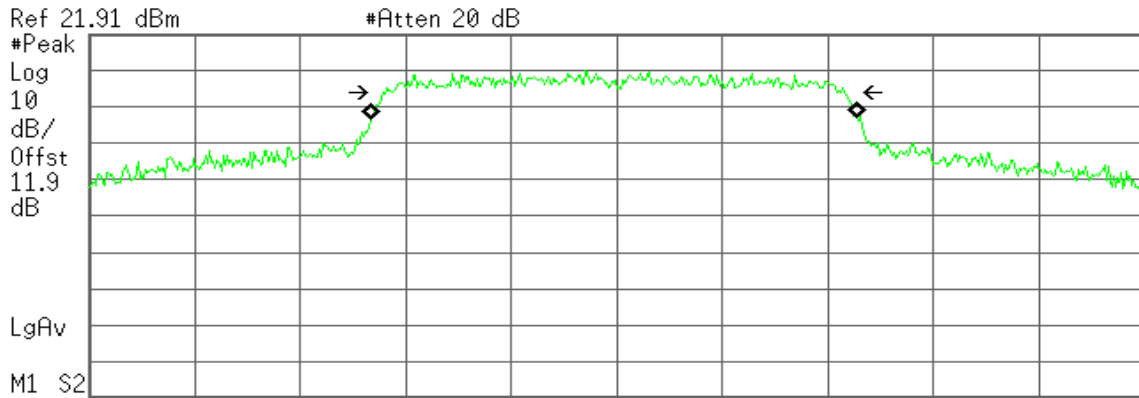

Ref 21.91 dBm #Atten 20 dB
#Peak
Log
10
dB/
Offst
11.9
dB
LgAv
M1 S2
Center 5.825 00 GHz Span 40 MHz
#Res BW 430 kHz #VBW 1.3 MHz Sweep 1 ms (601 pts)

Occupied Bandwidth
18.4769 MHz

Occ BW % Pwr 99.00 %
x dB -6.00 dB

Transmit Freq Error -87.365 kHz
x dB Bandwidth 17.486 MHz



IEEE 802.11n HT 40 mode / 5755 ~ 5795MHz / Chain 0

CH Low

Agilent

R T

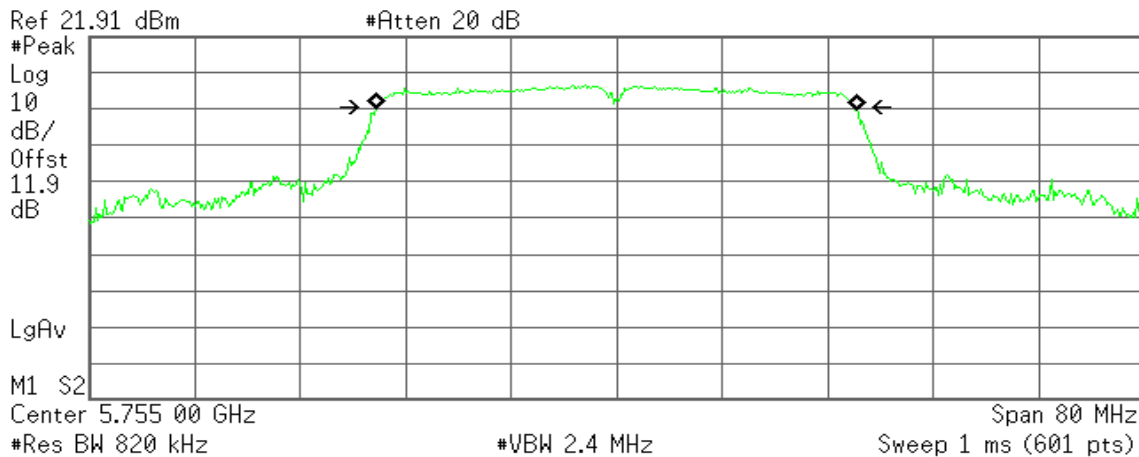

Occupied Bandwidth
36.5231 MHz

Occ BW % Pwr 99.00 %
x dB -6.00 dB

Transmit Freq Error -57.873 kHz
x dB Bandwidth 36.362 MHz

CH High

Agilent

R T

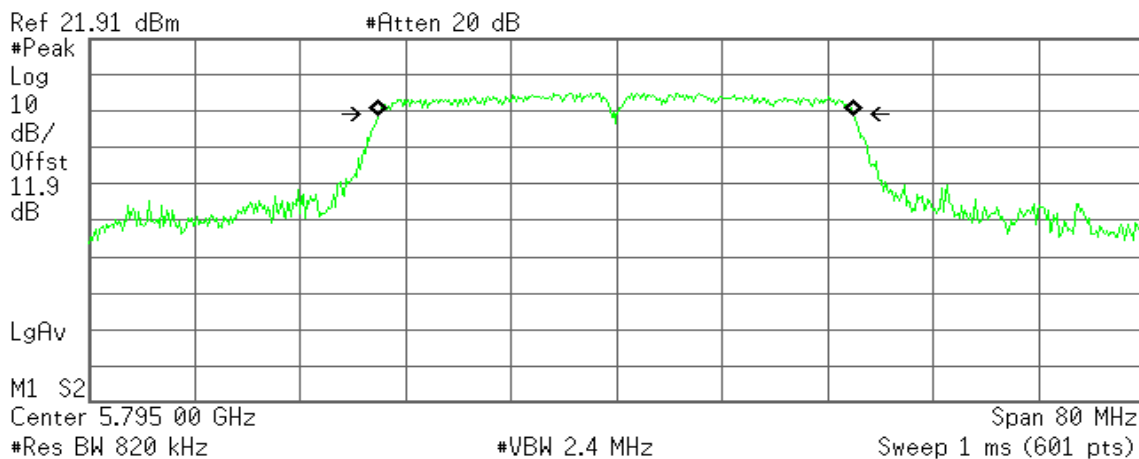

Occupied Bandwidth
36.1132 MHz

Occ BW % Pwr 99.00 %
x dB -6.00 dB

Transmit Freq Error -40.040 kHz
x dB Bandwidth 36.075 MHz



IEEE 802.11n HT 40 mode / 5755 ~ 5795MHz / Chain 1

CH Low

Agilent

R T

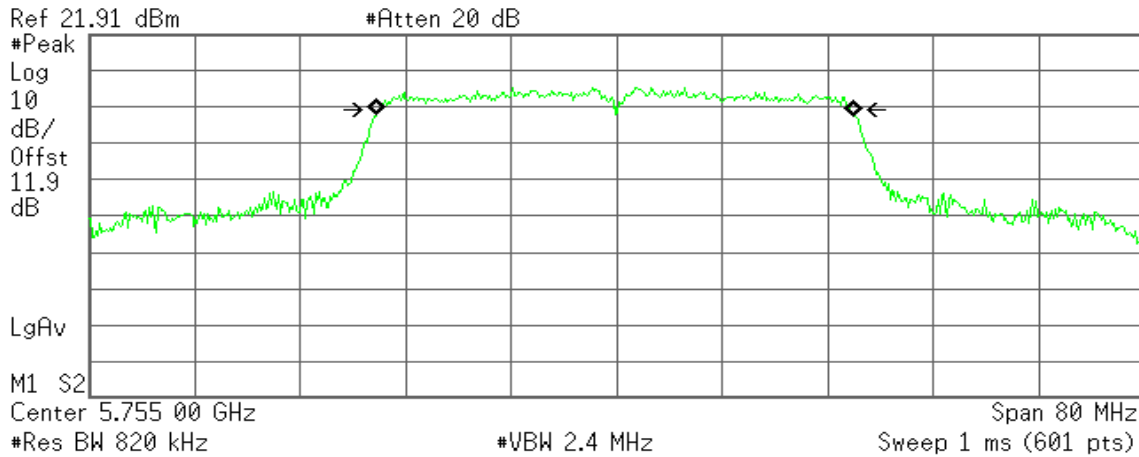

Occupied Bandwidth
36.2540 MHz

Occ BW % Pwr 99.00 %
x dB -6.00 dB

Transmit Freq Error -100.943 kHz
x dB Bandwidth 35.763 MHz

CH High

Agilent

R T

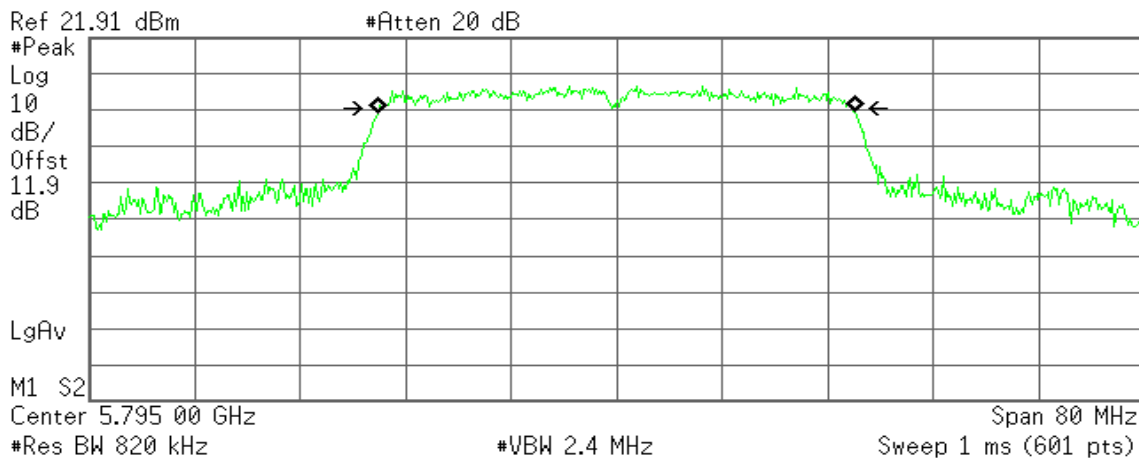

Occupied Bandwidth
36.2469 MHz

Occ BW % Pwr 99.00 %
x dB -6.00 dB

Transmit Freq Error -19.470 kHz
x dB Bandwidth 35.895 MHz



IEEE 802.11ac80 mode / 5775MHz / Chain 0

Agilent

R T

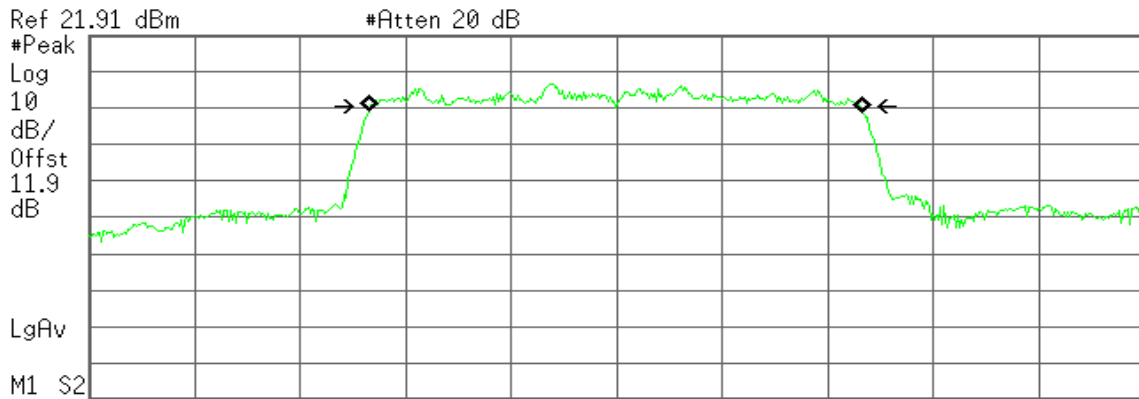

Center 5.775 0 GHz Span 160 MHz
 #Res BW 1.6 MHz #VBW 5 MHz Sweep 1 ms (601 pts)

Occupied Bandwidth
75.0113 MHz

Occ BW % Pwr 99.00 %
x dB -6.00 dB

Transmit Freq Error -47.954 kHz
x dB Bandwidth 74.471 MHz

IEEE 802.11ac80 mode / 5775MHz / Chain 1

Agilent

R T

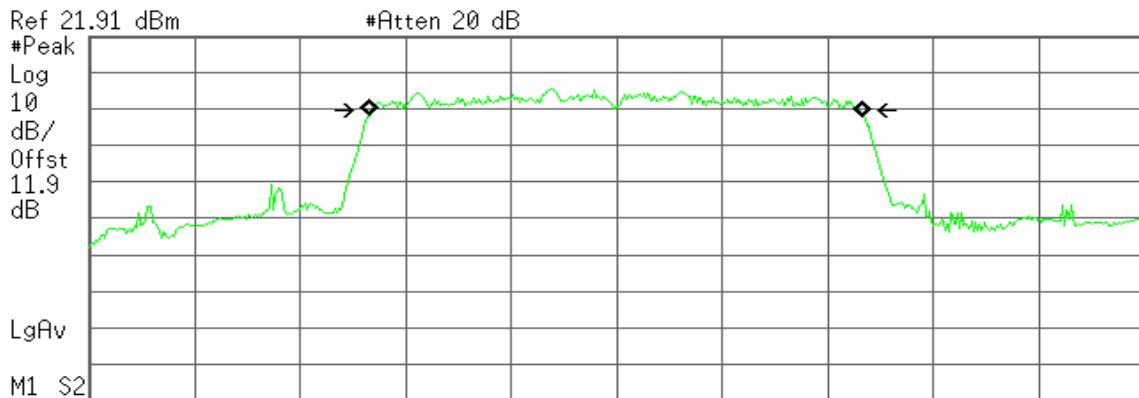

Center 5.775 0 GHz Span 160 MHz
 #Res BW 1.6 MHz #VBW 5 MHz Sweep 1 ms (601 pts)

Occupied Bandwidth
74.9064 MHz

Occ BW % Pwr 99.00 %
x dB -6.00 dB

Transmit Freq Error -58.001 kHz
x dB Bandwidth 74.360 MHz



7.2 AVERAGE POWER

LIMIT

None; for reporting purposes only.

Test Configuration

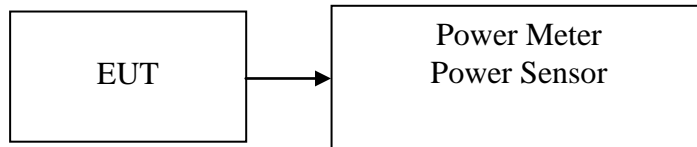

TEST PROCEDURE

The transmitter output is connected to the Power Meter. The Power Meter is set to the avg power detection.

TEST RESULTS

No non-compliance noted.

**Test Data****Test mode: IEEE 802.11a mode / 5180 ~ 5240MHz**

Channel	Frequency (MHz)	Maximum Conducted Output Power (dBm)	Limit (dBm)
Low	5180	19.67	24.00
Mid	5220	19.34	
High	5240	19.31	

Test mode: IEEE 802.11n HT 20 mode / 5180 ~ 5240MHz

Channel	Frequency (MHz)	Chain 0 Output Power (dBm)	Chain 1 Output Power (dBm)	Total Maximum Conducted Output Power (dBm)	Limit (dBm)
Low	5180	19.02	17.75	21.44	24.00
Mid	5220	18.54	17.05	20.87	
High	5240	18.44	16.51	20.59	

Test mode: IEEE 802.11n HT 40 mode / 5190 ~ 5230MHz

Channel	Frequency (MHz)	Chain 0 Output Power (dBm)	Chain 1 Output Power (dBm)	Total Maximum Conducted Output Power (dBm)	Limit (dBm)
Low	5190	14.11	13.59	16.87	24.00
High	5230	16.14	15.34	18.77	

Test mode: IEEE 802.11n HT 80 MHz mode / 5210MHz

Channel	Frequency (MHz)	Chain 0 Output Power (dBm)	Chain 1 Output Power (dBm)	Total Maximum Conducted Output Power (dBm)	Limit (dBm)
Mid	5210	12.82	12.27	15.56	24.00

Remark: 1. Total PPSD (dBm) = $10 * \text{LOG}(10^{(\text{Chain 0 PPSD} / 10)} + 10^{(\text{Chain 1 PPSD} / 10)})$



Test mode: IEEE 802.11a mode / 5745 ~ 5825MHz

Channel	Frequency (MHz)	Maximum Conducted Output Power (dBm)	Limit (dBm)
Low	5745	20.25	24.00
Mid	5785	20.42	24.00
High	5825	20.65	24.00

Test mode: IEEE 802.11n HT 20 mode / 5745 ~ 5825MHz

Channel	Frequency (MHz)	Chain 0 Output Power (dBm)	Chain 1 Output Power (dBm)	Total Maximum Conducted Output Power (dBm)	Limit (dBm)
Low	5745	19.31	18.47	21.92	30.00
Mid	5785	19.33	18.65	22.01	
High	5825	19.45	18.69	22.10	

Test mode: IEEE 802.11n HT 40 mode / 5755 ~ 5795MHz

Channel	Frequency (MHz)	Chain 0 Output Power (dBm)	Chain 1 Output Power (dBm)	Total Maximum Conducted Output Power (dBm)	Limit (dBm)
Low	5755	15.74	15.15	18.47	30.00
High	5795	15.39	15.20	18.31	

Test mode: IEEE 802.11n HT 80 MHz mode / 5775MHz

Channel	Frequency (MHz)	Chain 0 Output Power (dBm)	Chain 1 Output Power (dBm)	Total Maximum Conducted Output Power (dBm)	Limit (dBm)
Mid	5775	13.90	14.68	17.32	30.00

Remark: 1. Total PPSD (dBm) = 10*LOG(10^(Chain 0 PPSD / 10)+10^(Chain 1 PPSD / 10))



7.3 BAND EDGES MEASUREMENT

LIMIT

According to §15.407(b),

- (1) The provisions of Section 15.205 of this part apply to intentional radiators operating under this section.
- (2) When measuring the emission limits, the nominal carrier frequency shall be adjusted as close to the upper and lower frequency block edges as the design of the equipment permits.

Test Configuration

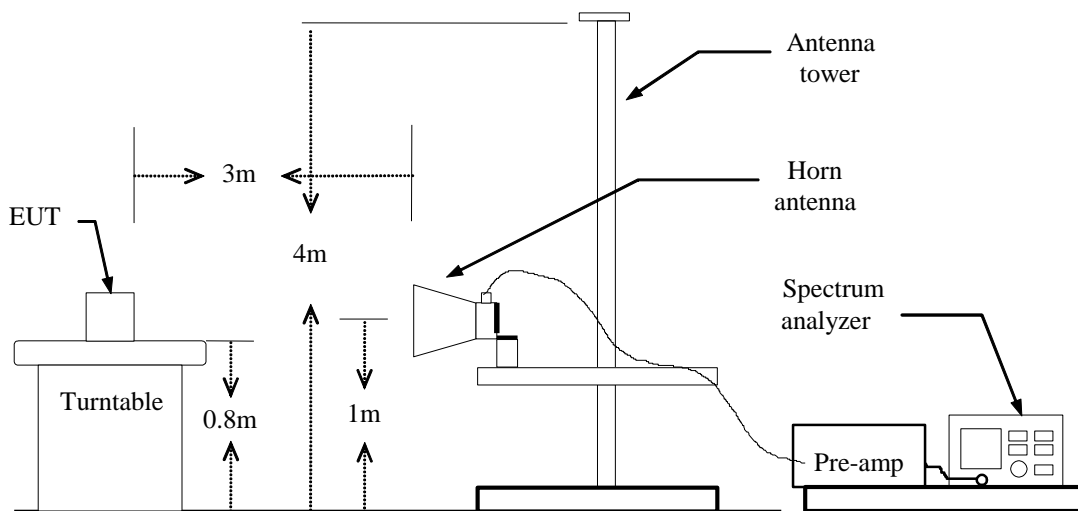

TEST PROCEDURE

1. The EUT is placed on a turntable, which is 0.8m above the ground plane.
2. The turntable shall be rotated for 360 degrees to determine the position of maximum emission level.
3. EUT is set 3m away from the receiving antenna, which is varied from 1m to 4m to find out the highest emission.
4. Set the spectrum analyzer in the following setting in order to capture the lower and upper band-edges of the emission:
 - (a) PEAK: RBW=VBW=1MHz / Sweep=AUTO
 - (b) AVERAGE: RBW=1MHz / VBW=10Hz / Sweep=AUTO
5. Repeat the procedures until all the PEAK and AVERAGE versus POLARIZATION are measured.

TEST RESULTS

Refer to attach spectrum analyzer data chart.



For printed Antenna

Band Edges (IEEE 802.11a mode / 5180 MHz)

Polarity: Vertical

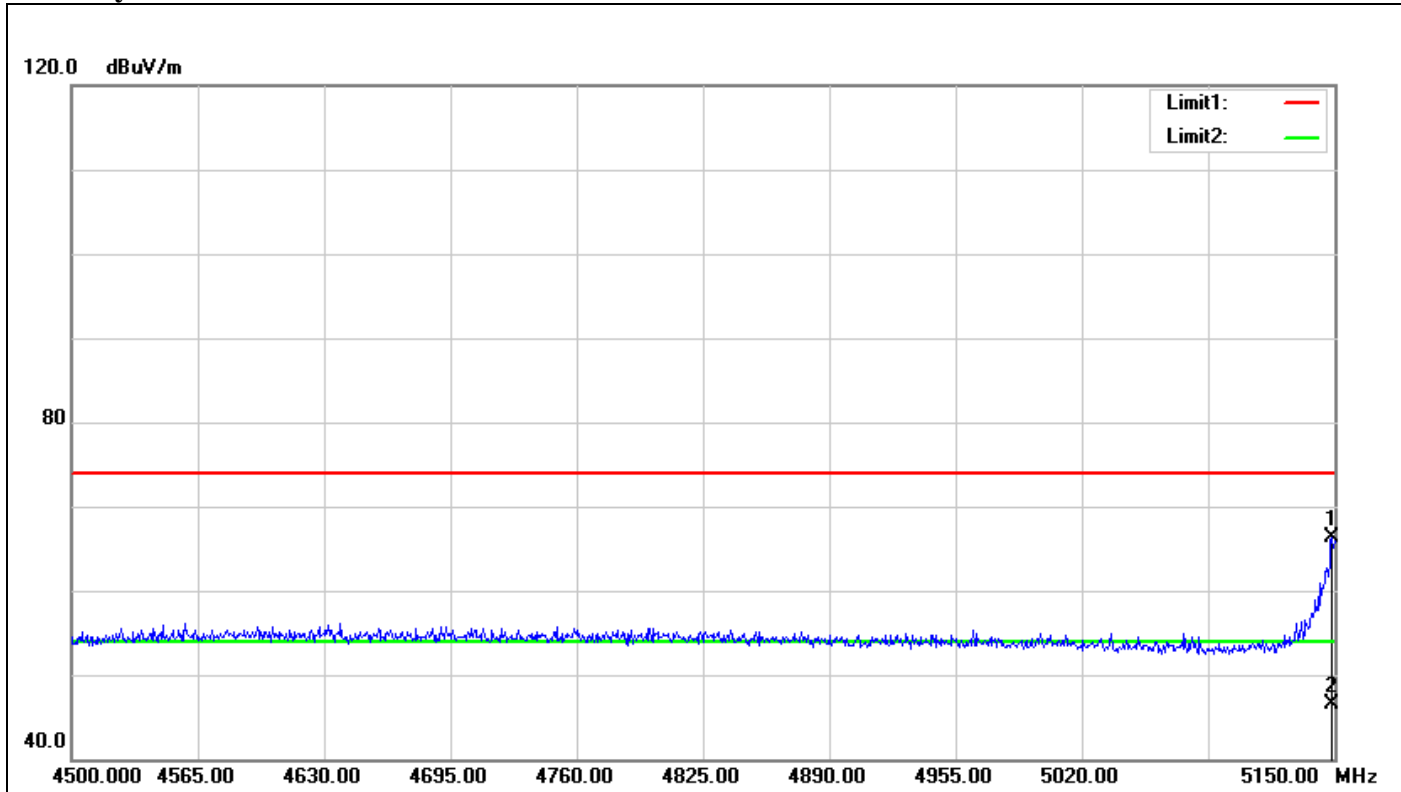

No.	Frequency (MHz)	Reading (dBuV)	Correct Factor(dB/m)	Result (dBuV/m)	Limit (dBuV/m)	Margin (dB)	Height (cm)	Degree (°)	Remark
1	5148.700	63.22	3.03	66.25	74.00	-7.75	100	248	peak
2	5148.700	43.50	3.03	46.53	54.00	-7.47	100	248	AVG



Polarity: Horizontal

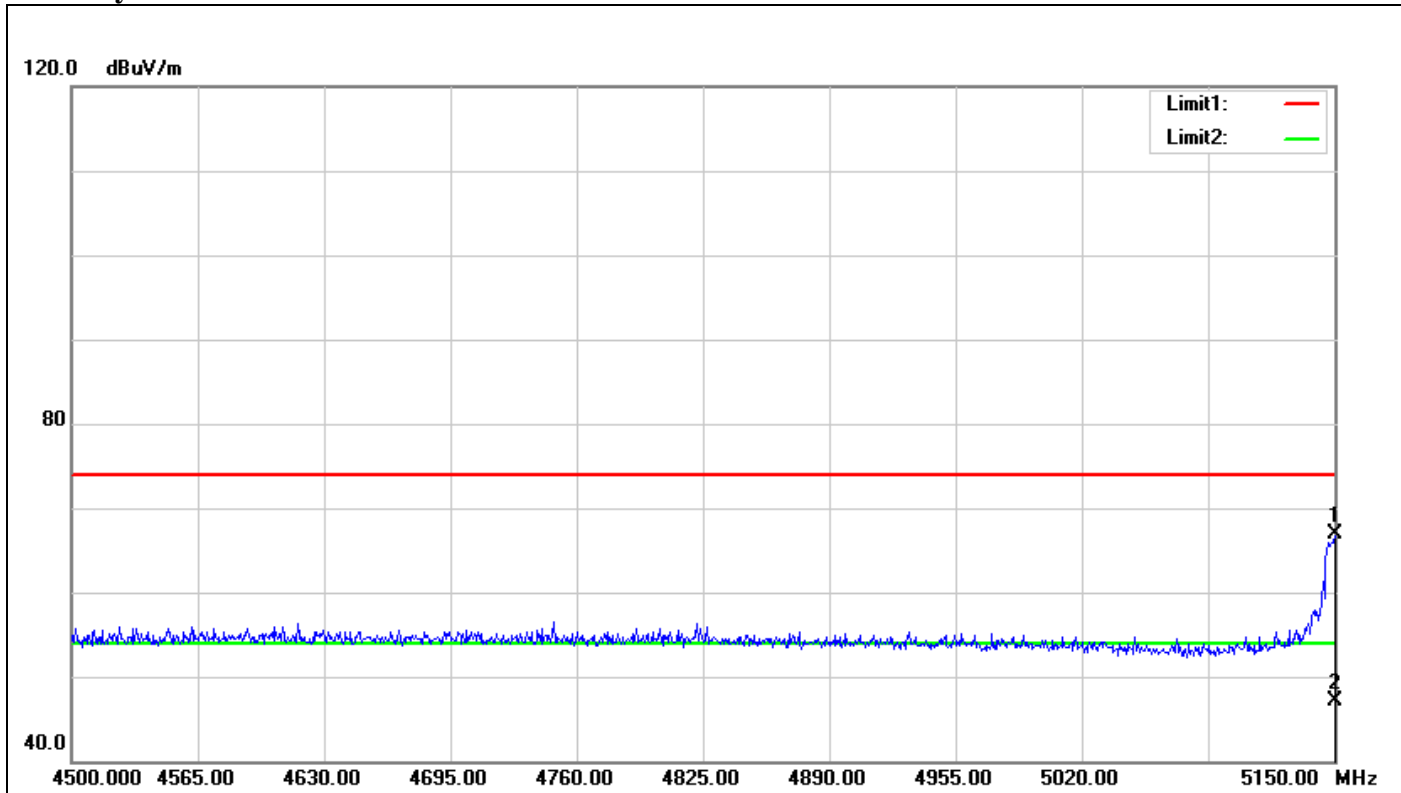

No.	Frequency (MHz)	Reading (dBuV)	Correct Factor(dB/m)	Result (dBuV/m)	Limit (dBuV/m)	Margin (dB)	Height (cm)	Degree (°)	Remark
1	5150.000	63.87	3.04	66.91	74.00	-7.09	100	250	peak
2	5150.000	44.15	3.04	47.19	54.00	-6.81	100	250	AVG



Band Edges (IEEE 802.11n HT 20 mode / 5180 MHz)

Polarity: Vertical

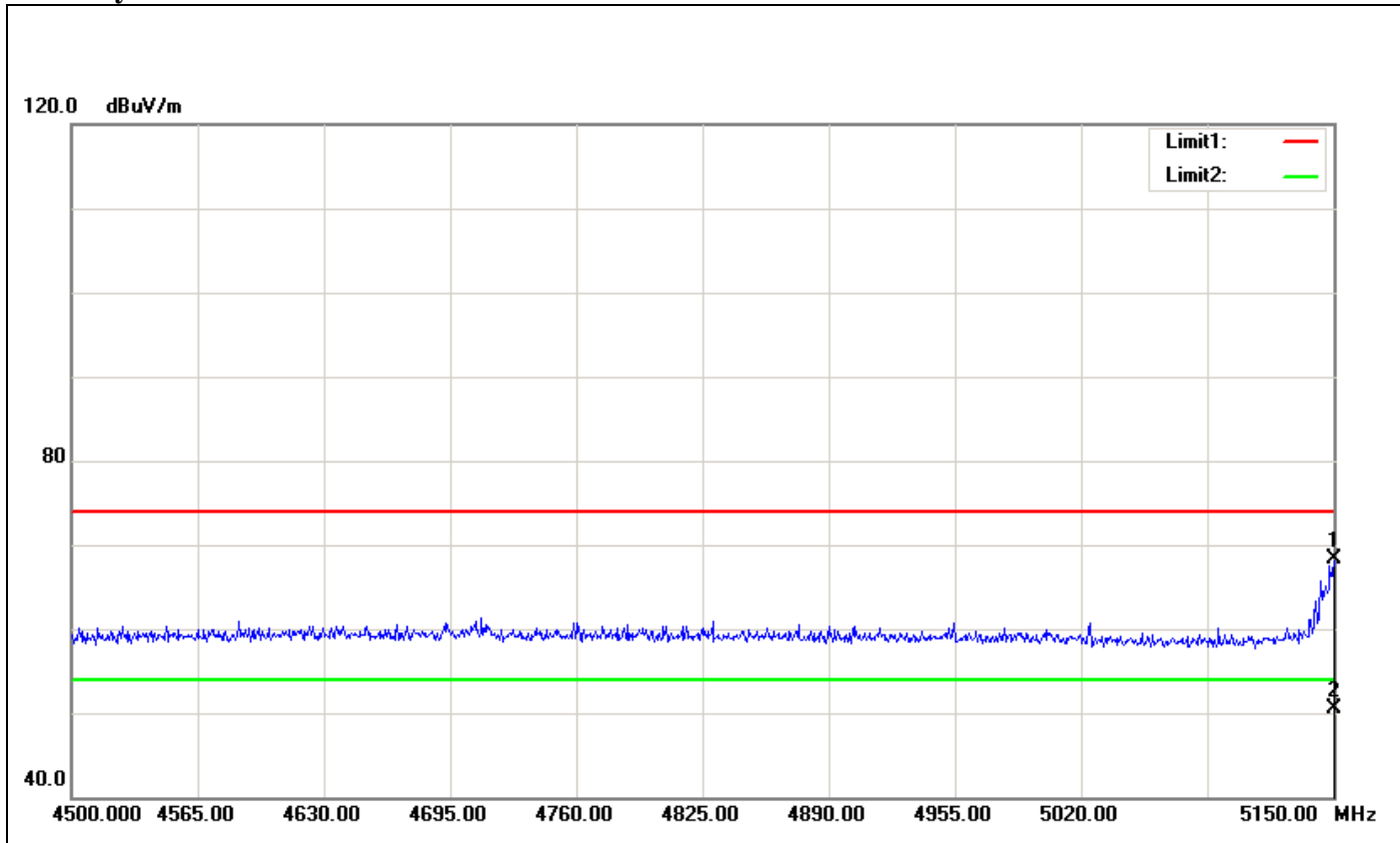

No.	Frequency (MHz)	Reading (dBuV)	Correct Factor(dB/m)	Result (dBuV/m)	Limit (dBuV/m)	Margin (dB)	Height (cm)	Degree (°)	Remark
1	5150.000	60.57	7.74	68.31	74.00	-5.69	100	0	peak
2	5150.000	42.71	7.74	50.45	54.00	-3.55	100	0	AVG



Polarity: Horizontal

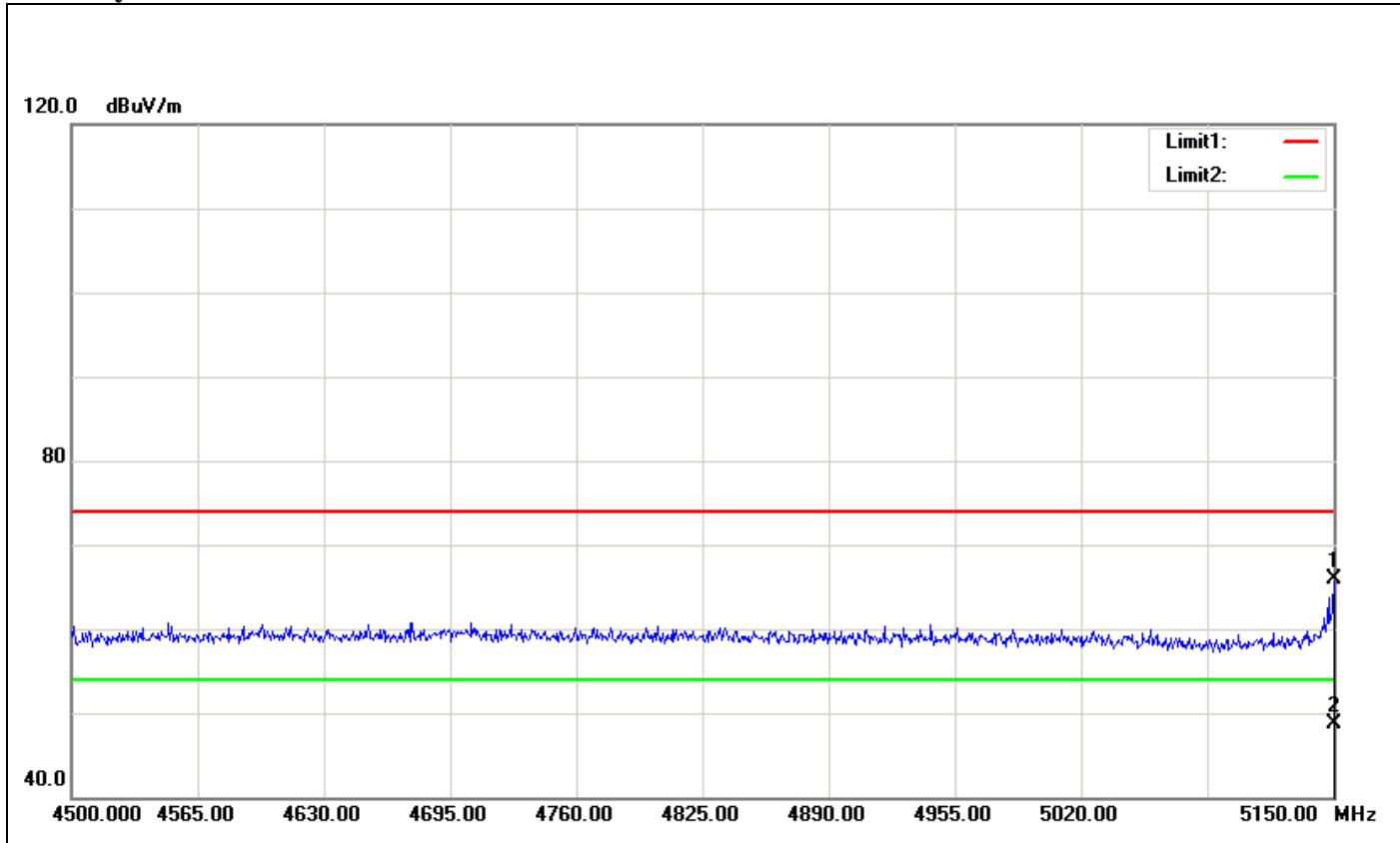

No.	Frequency (MHz)	Reading (dBuV)	Correct Factor(dB/m)	Result (dBuV/m)	Limit (dBuV/m)	Margin (dB)	Height (cm)	Degree (°)	Remark
1	5150.000	58.20	7.74	65.94	74.00	-8.06	100	115	peak
2	5150.000	40.87	7.74	48.61	54.00	-5.39	100	115	AVG



Band Edges (IEEE 802.11n HT 40 mode / 5190 MHz)

Polarity: Vertical

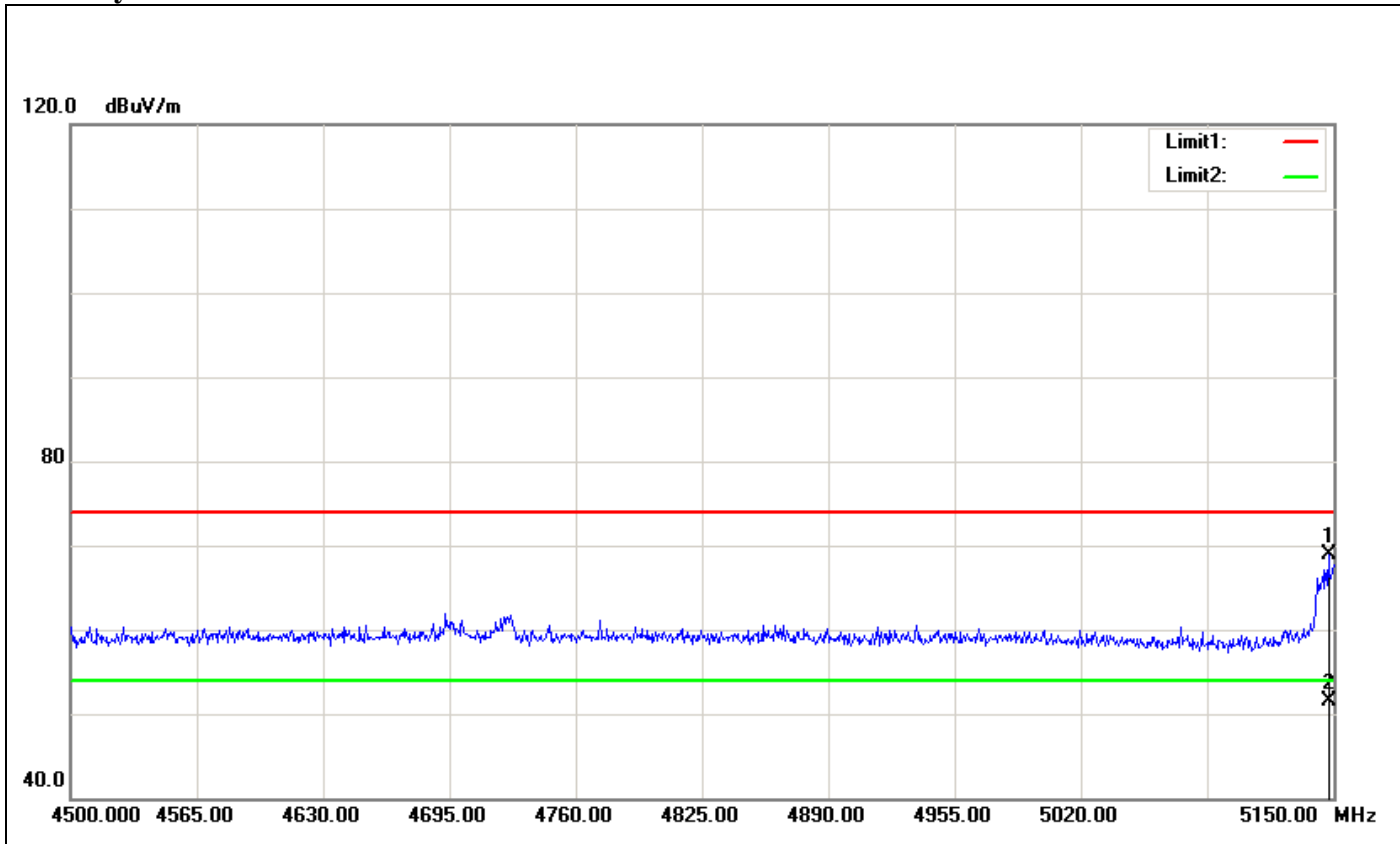

No.	Frequency (MHz)	Reading (dBuV)	Correct Factor(dB/m)	Result (dBuV/m)	Limit (dBuV/m)	Margin (dB)	Height (cm)	Degree (°)	Remark
1	5147.400	61.23	7.73	68.96	74.00	-5.04	100	258	peak
2	5147.400	43.70	7.73	51.43	54.00	-2.57	100	258	AVG



Polarity: Horizontal

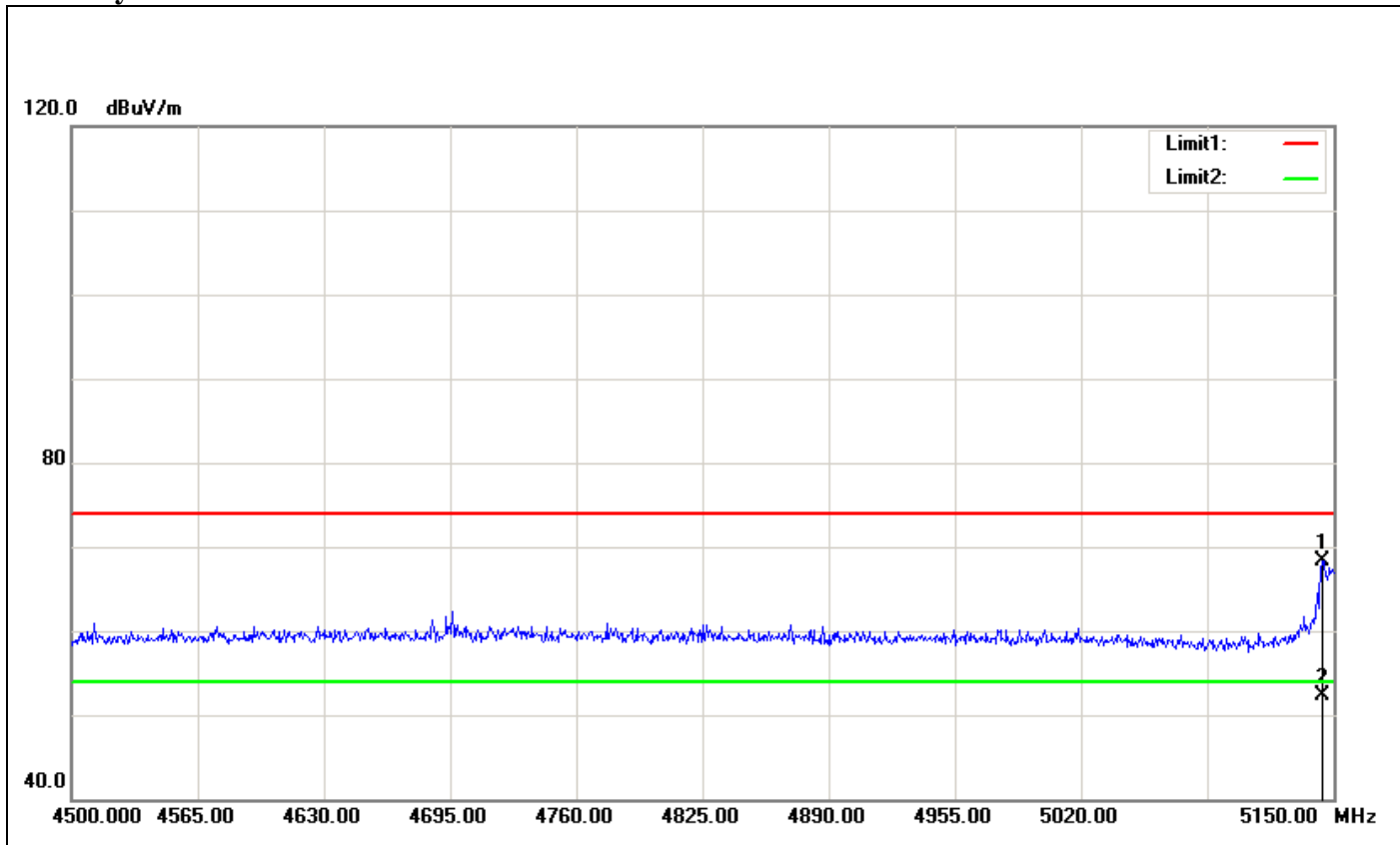

No.	Frequency (MHz)	Reading (dBuV)	Correct Factor(dB/m)	Result (dBuV/m)	Limit (dBuV/m)	Margin (dB)	Height (cm)	Degree (°)	Remark
1	5144.150	60.60	7.72	68.32	74.00	-5.68	100	1	peak
2	5144.150	44.48	7.72	52.20	54.00	-1.80	100	1	AVG



Band Edges (IEEE 802.11n HT 80 MHz mode / CH 5210 MHz)

Polarity: Vertical

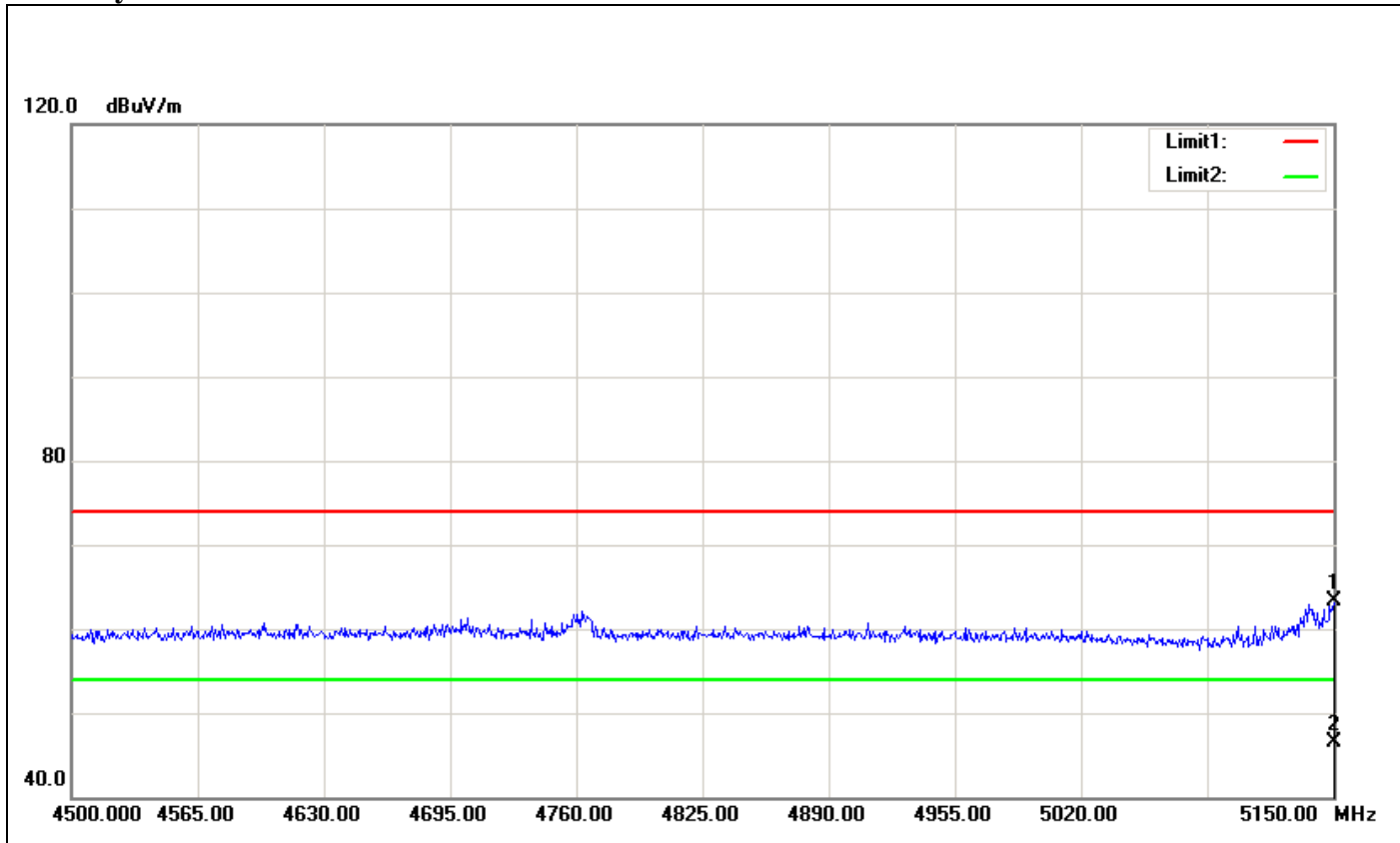

No.	Frequency (MHz)	Reading (dBuV)	Correct Factor(dB/m)	Result (dBuV/m)	Limit (dBuV/m)	Margin (dB)	Height (cm)	Degree (°)	Remark
1	5150.000	55.51	7.74	63.25	74.00	-10.75	100	59	peak
2	5150.000	38.85	7.74	46.59	54.00	-7.41	100	59	AVG



Polarity: Horizontal

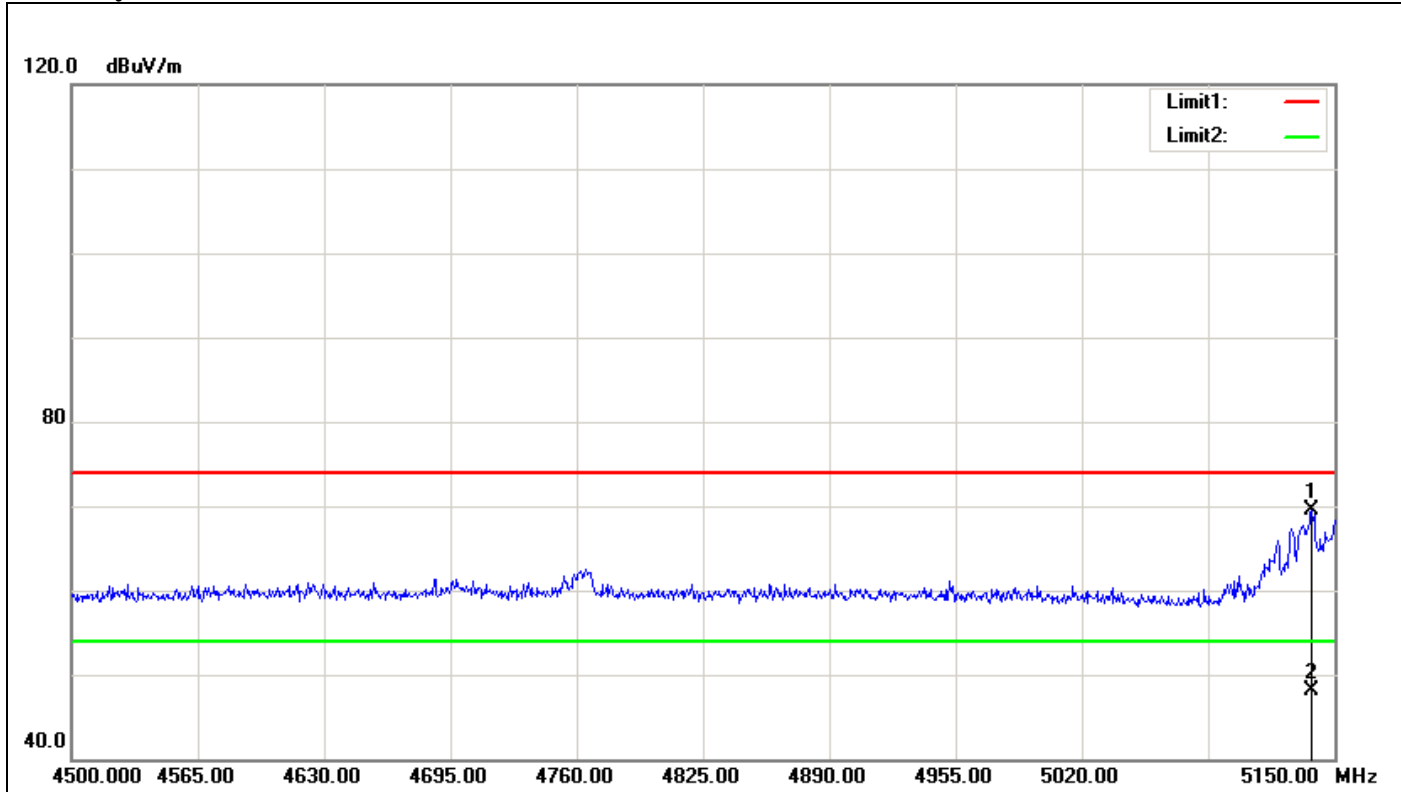

No.	Frequency (MHz)	Reading (dBuV)	Correct Factor(dB/m)	Result (dBuV/m)	Limit (dBuV/m)	Margin (dB)	Height (cm)	Degree (°)	Remark
1	5138.300	61.80	7.69	69.49	74.00	-4.51	100	28	peak
2	5138.300	40.46	7.69	48.15	54.00	-5.85	100	28	AVG



For Dipole Antenna

Band Edges (IEEE 802.11a mode / 5180 MHz)

Polarity: Vertical

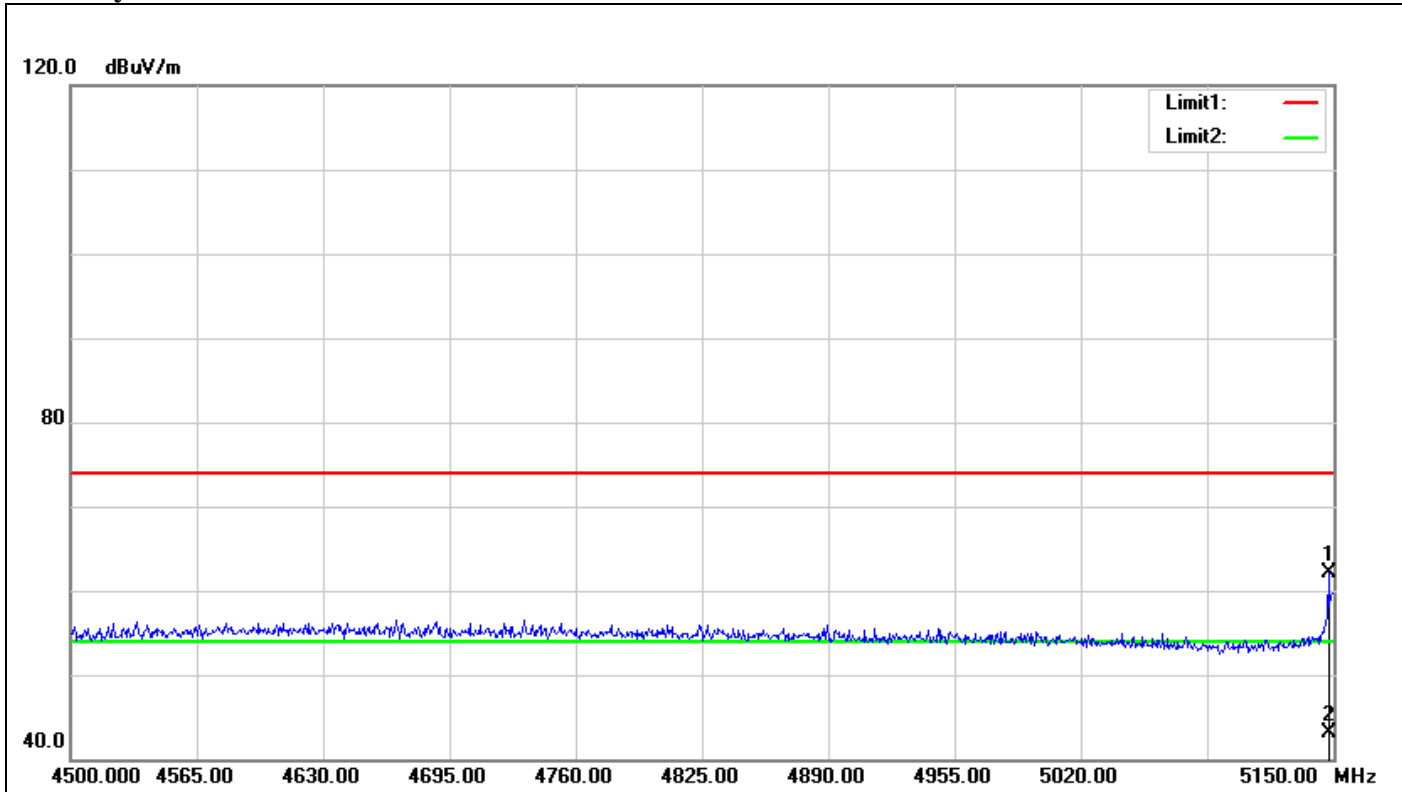

No.	Frequency (MHz)	Reading (dBuV)	Correct Factor(dB/m)	Result (dBuV/m)	Limit (dBuV/m)	Margin (dB)	Height (cm)	Degree (°)	Remark
1	5147.400	59.06	3.02	62.08	74.00	-11.92	100	241	peak
2	5147.400	40.00	3.02	43.02	54.00	-10.98	100	241	AVG



Polarity: Horizontal

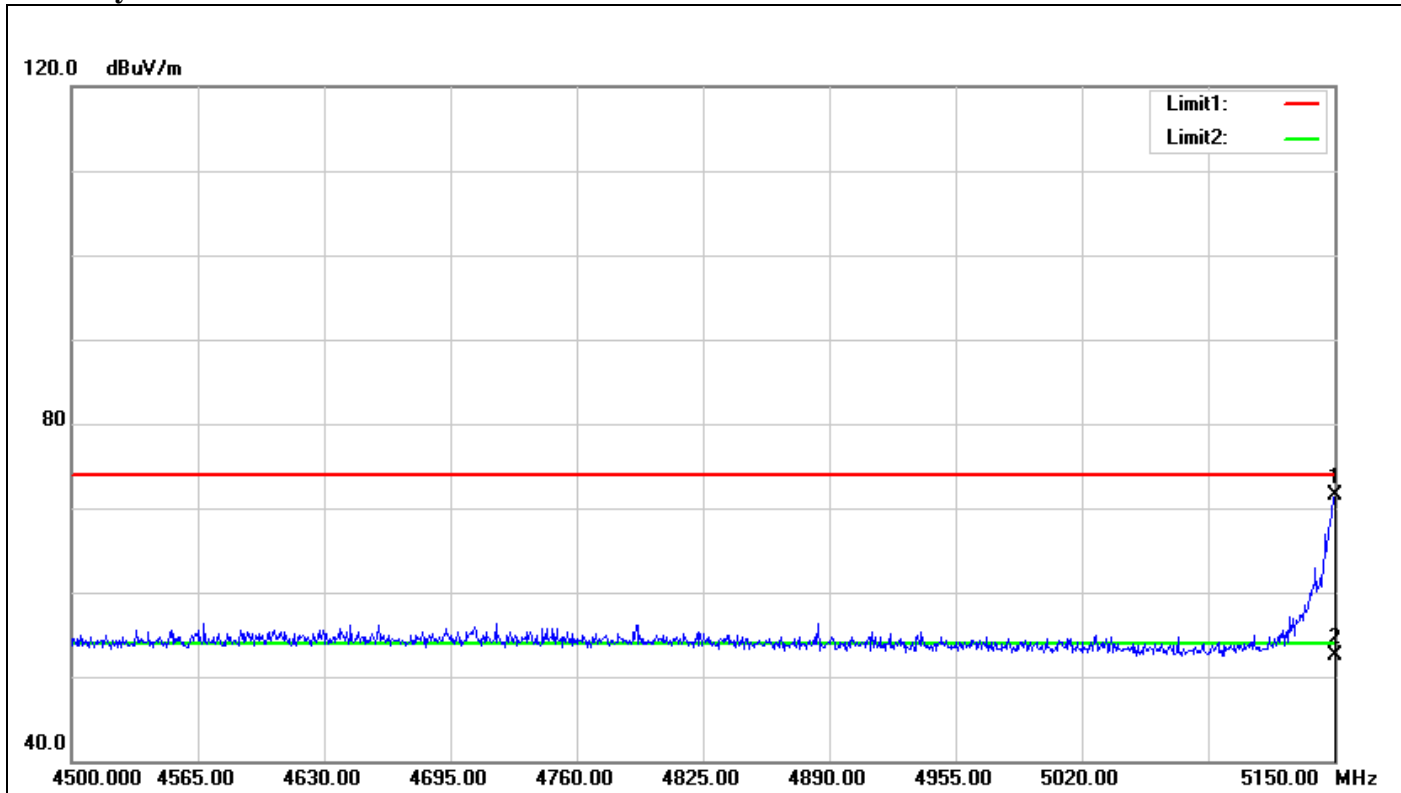

No.	Frequency (MHz)	Reading (dBuV)	Correct Factor(dB/m)	Result (dBuV/m)	Limit (dBuV/m)	Margin (dB)	Height (cm)	Degree (°)	Remark
1	5150.000	68.44	3.04	71.48	74.00	-2.52	100	155	peak
2	5150.000	49.50	3.04	52.54	54.00	-1.46	100	155	AVG



Band Edges (IEEE 802.11n HT 20 mode / 5180 MHz)

Polarity: Vertical

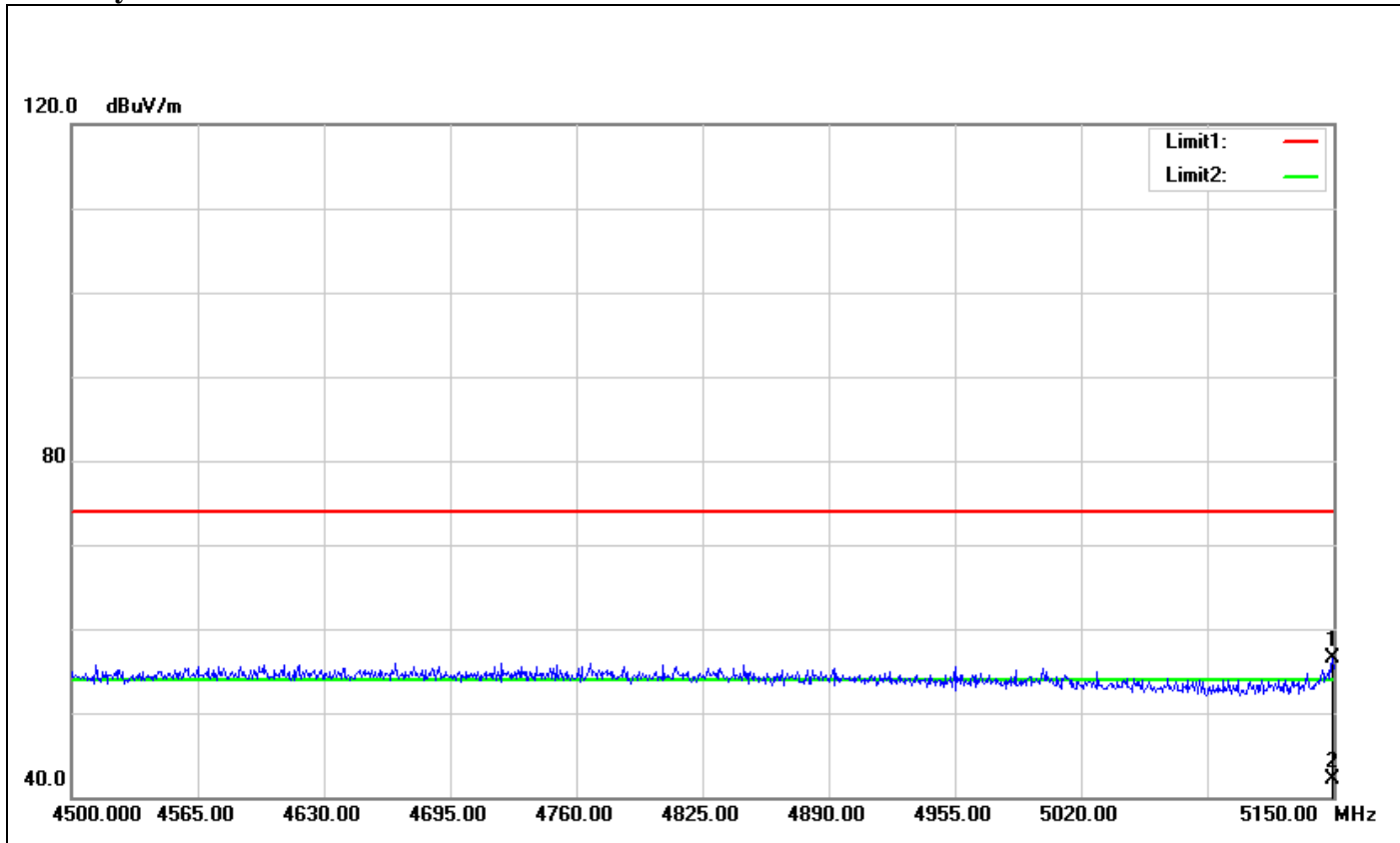

No.	Frequency (MHz)	Reading (dBuV)	Correct Factor(dB/m)	Result (dBuV/m)	Limit (dBuV/m)	Margin (dB)	Height (cm)	Degree (°)	Remark
1	5149.350	53.44	3.04	56.48	74.00	-17.52	100	194	peak
2	5149.350	38.98	3.04	42.02	54.00	-11.98	100	194	AVG



Polarity: Horizontal

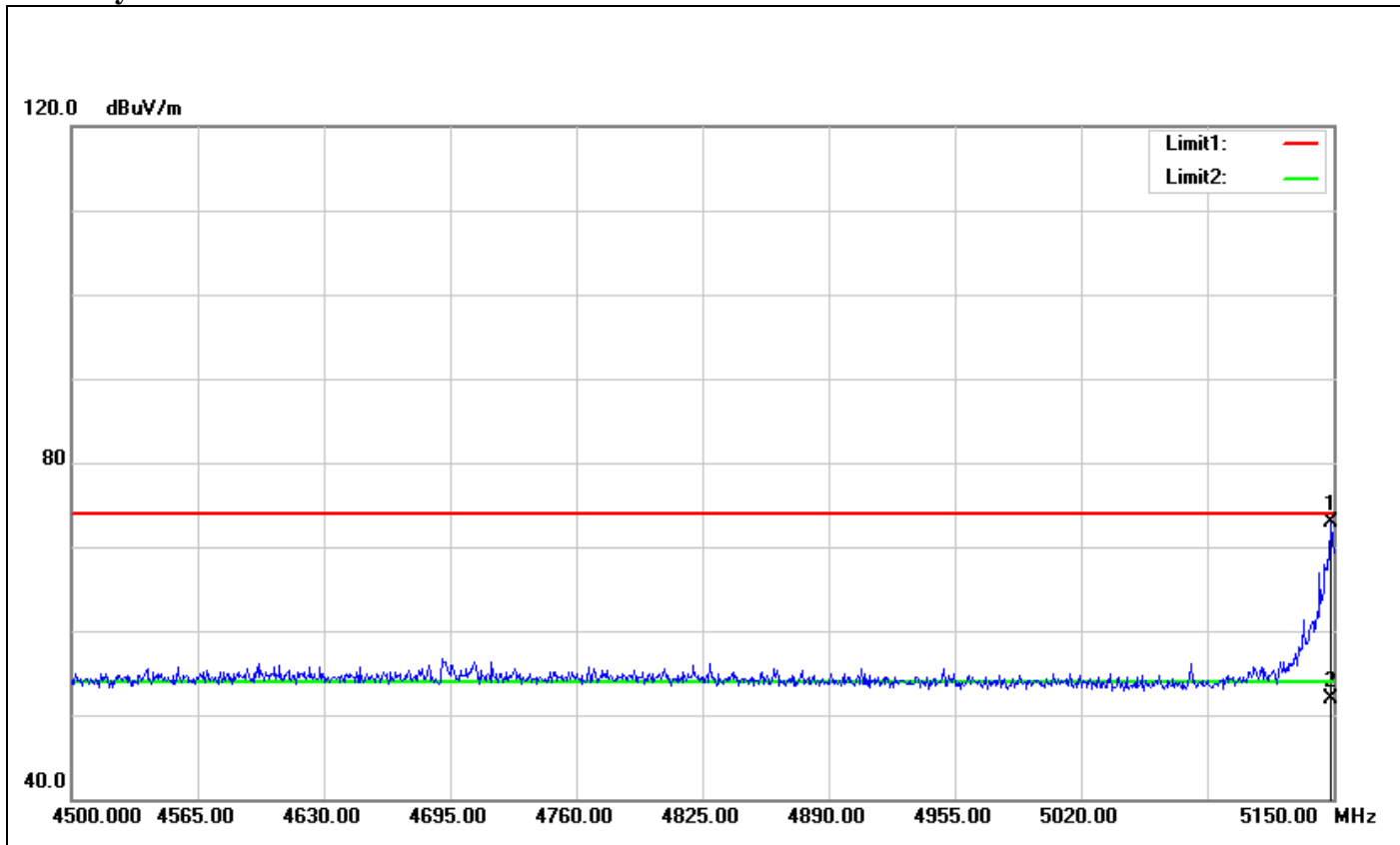

No.	Frequency (MHz)	Reading (dBuV)	Correct Factor(dB/m)	Result (dBuV/m)	Limit (dBuV/m)	Margin (dB)	Height (cm)	Degree (°)	Remark
1	5148.700	69.91	3.03	72.94	74.00	-1.06	100	321	peak
2	5148.700	48.78	3.03	51.81	54.00	-2.19	100	321	AVG



Band Edges (IEEE 802.11n HT 40 mode / 5190 MHz)

Polarity: Vertical

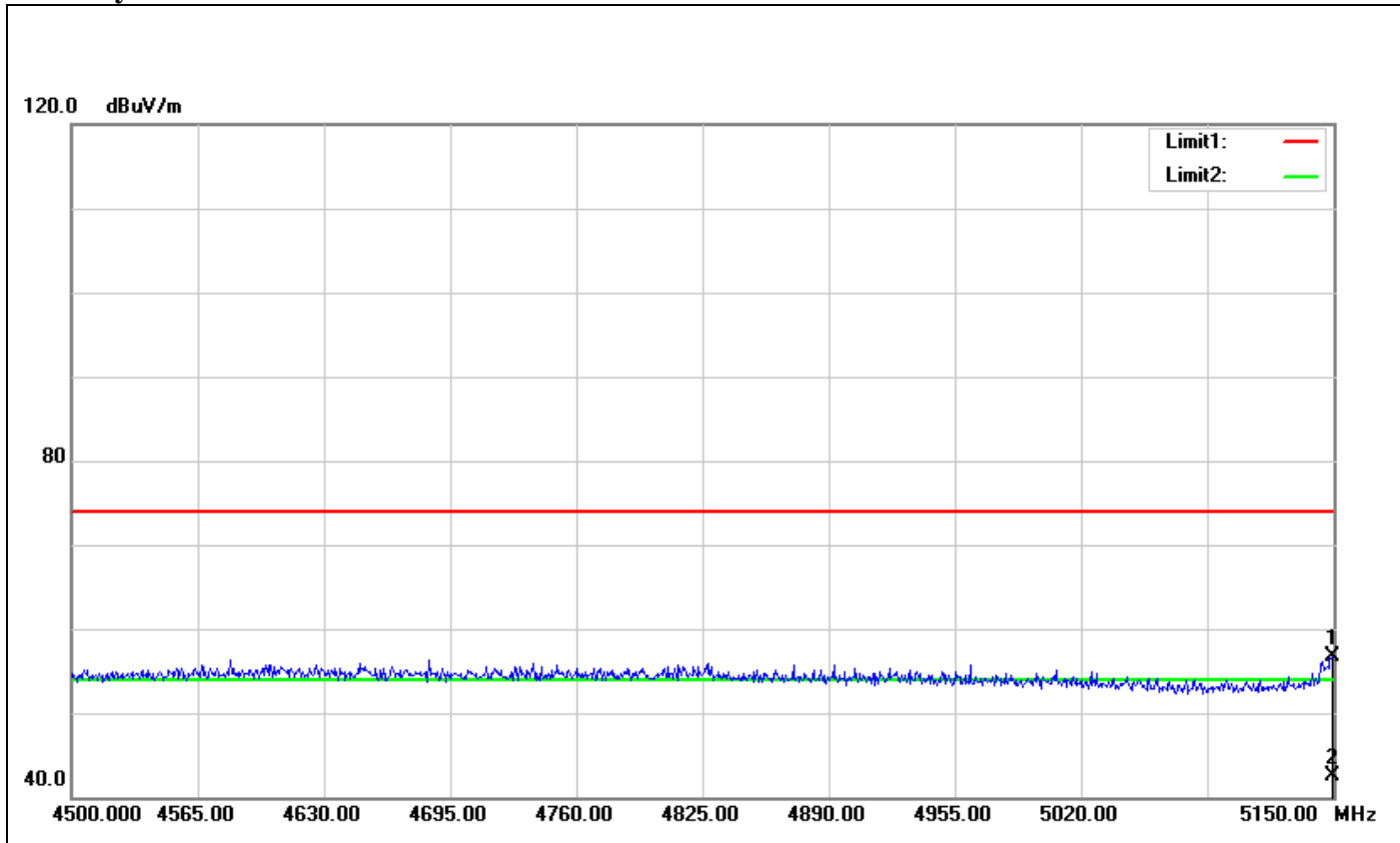

No.	Frequency (MHz)	Reading (dBuV)	Correct Factor(dB/m)	Result (dBuV/m)	Limit (dBuV/m)	Margin (dB)	Height (cm)	Degree (°)	Remark
1	5149.350	53.73	3.04	56.77	74.00	-17.23	100	274	peak
2	5149.350	39.46	3.04	42.50	54.00	-11.50	100	274	AVG



Polarity: Horizontal

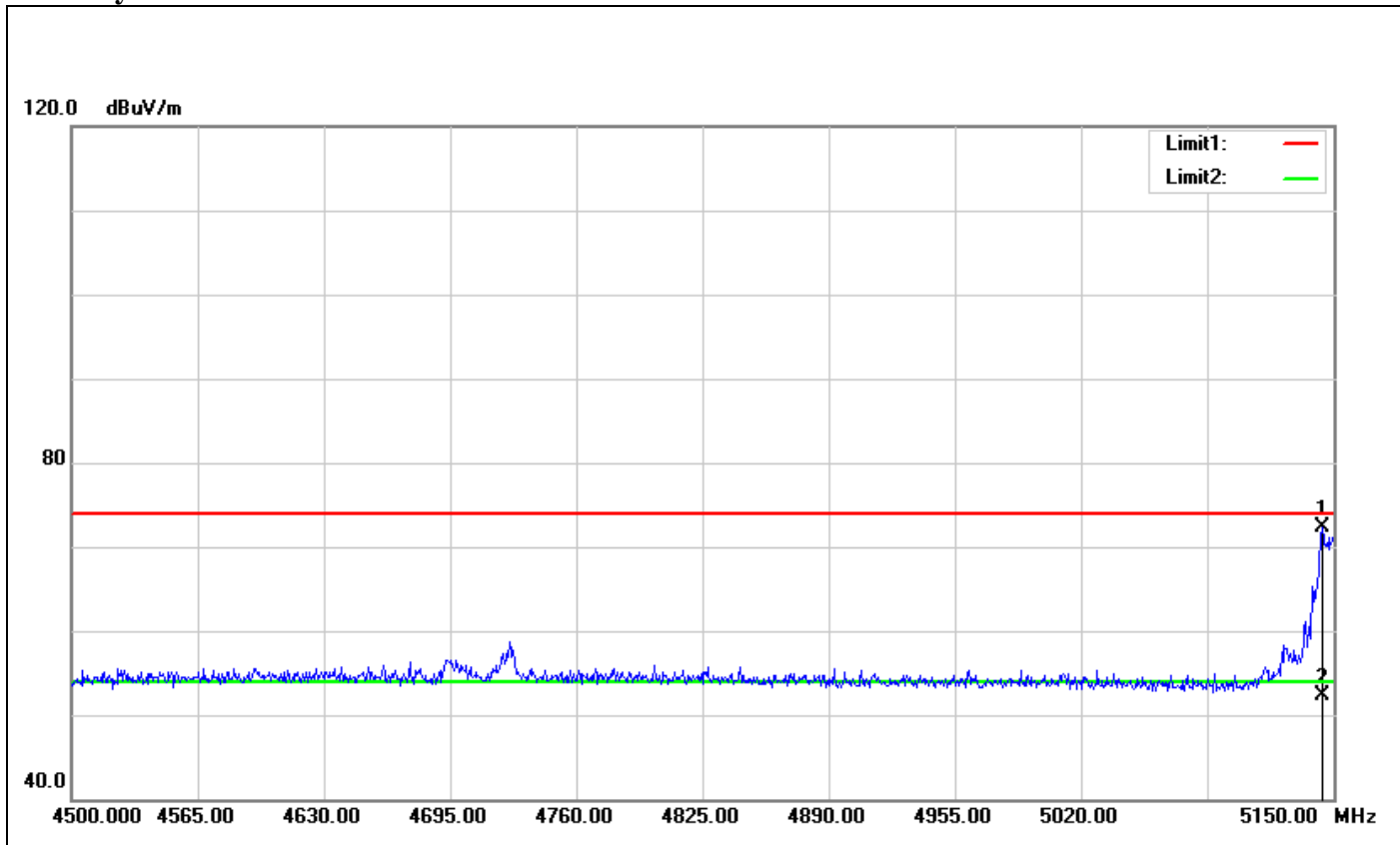

No.	Frequency (MHz)	Reading (dBuV)	Correct Factor(dB/m)	Result (dBuV/m)	Limit (dBuV/m)	Margin (dB)	Height (cm)	Degree (°)	Remark
1	5144.150	69.32	3.00	72.32	74.00	-1.68	100	23	peak
2	5144.150	49.26	3.00	52.26	54.00	-1.74	100	23	AVG



Band Edges (IEEE 802.11n HT 80 MHz mode / CH 5210 MHz)

Polarity: Vertical

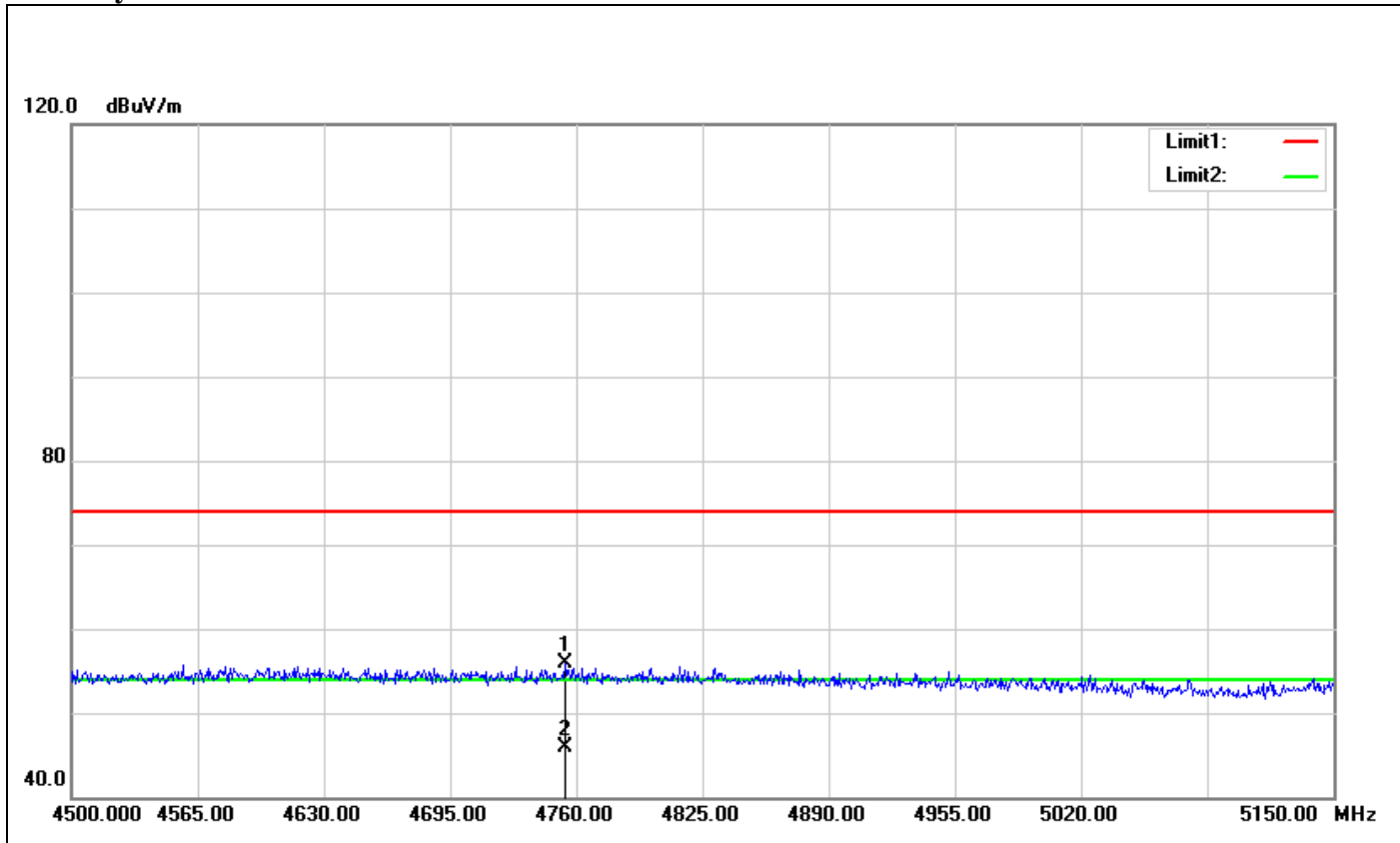

No.	Frequency (MHz)	Reading (dBuV)	Correct Factor(dB/m)	Result (dBuV/m)	Limit (dBuV/m)	Margin (dB)	Height (cm)	Degree (°)	Remark
1	4754.150	52.12	3.87	55.99	74.00	-18.01	100	142	peak
2	4754.150	41.99	3.87	45.86	54.00	-8.14	100	142	AVG



Polarity: Horizontal

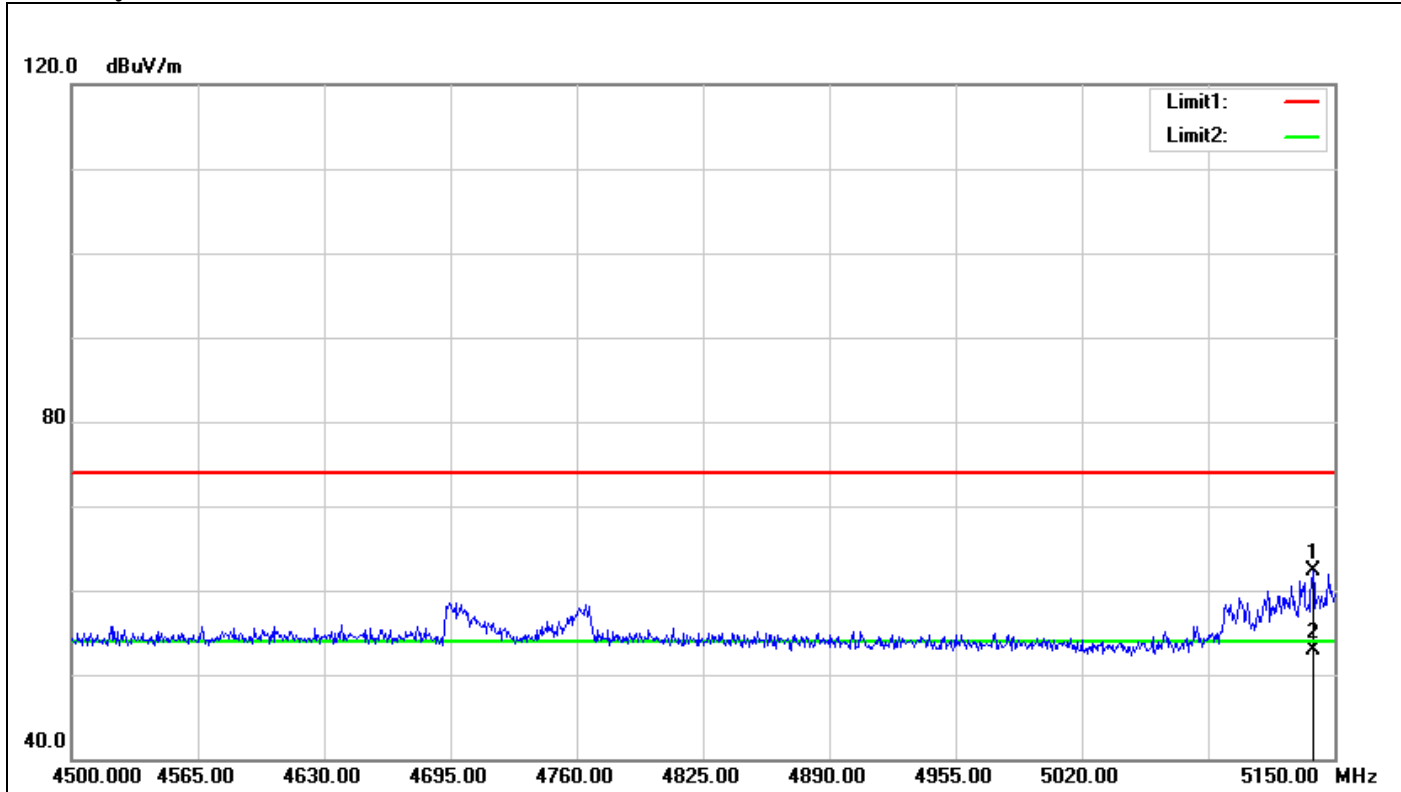

No.	Frequency (MHz)	Reading (dBuV)	Correct Factor(dB/m)	Result (dBuV/m)	Limit (dBuV/m)	Margin (dB)	Height (cm)	Degree (°)	Remark
1	5138.950	59.33	2.96	62.29	74.00	-11.71	100	222	peak
2	5138.950	50.02	2.96	52.98	54.00	-1.02	100	222	AVG



7.4 PEAK POWER SPECTRAL DENSITY

LIMIT

According to §15.407(a),

- (1) For the band 5.15-5.25 GHz, the peak power spectral density shall not exceed 4dBm in any 1MHz band.
- (2) For the band 5.25-5.35 GHz, the peak power spectral density shall not exceed 11dBm in any 1MHz band.

If transmitting antennas of directional gain greater than 6dBi are used, both the peak transmit power and the peak power spectral density shall be reduced by the amount in dB that the directional gain of the antenna exceeds 6dBi.

Test Configuration

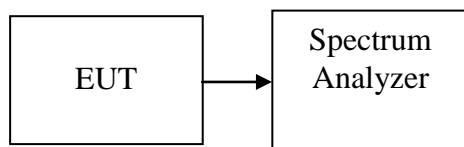

TEST PROCEDURE

1. Place the EUT on the table and set it in transmitting mode.
Remove the antenna from the EUT and then connect a low loss RF cable from the antenna port to the spectrum analyzer.
2. Set the spectrum analyzer as RBW = 1MHz, VBW = 3MHz, Span = 50MHz, Sweep=1ms
3. Record the max. reading.
4. Repeat the above procedure until the measurements for all frequencies are completed

TEST RESULTS

No non-compliance noted

**Test Data****Test mode: IEEE 802.11a mode / 5180 ~ 5240MHz**

Channel	Frequency (MHz)	PPSD (dBm)	Limit (dBm)	Result
Low	5180	7.47	4.00	PASS
Mid	5220	6.32		PASS
High	5240	6.55		PASS

Test mode: IEEE 802.11n HT 20 mode / 5180 ~ 5240MHz

Channel	Frequency (MHz)	Chain 0 PPSD (dBm)	Chain 1 PPSD (dBm)	PPSD (dBm)	Limit (dBm)	Result
Low	5180	6.15	6.45	9.31	2	PASS
Mid	5220	4.85	6.39	8.70		PASS
High	5240	5.08	6.35	8.77		PASS

Test mode: IEEE 802.11n HT 40 mode / 5190 ~ 5230MHz

Channel	Frequency (MHz)	Chain 0 PPSD (dBm)	Chain 1 PPSD (dBm)	PPSD (dBm)	Limit (dBm)	Result
Low	5190	-0.89	-2.05	1.58	2	PASS
High	5230	0.56	0.39	3.49		PASS

Test mode: IEEE 802.11n HT 80 MHz mode / 5210MHz

Channel	Frequency (MHz)	Chain 0 PPSD (dBm)	Chain 1 PPSD (dBm)	PPSD (dBm)	Limit (dBm)	Result
Mid	5210	-7.93	-8.74	-5.31	2	PASS

Remark: 1. Total PPSD (dBm) = $10 * \text{LOG}(10^{\text{Chain 0 PPSD} / 10} + 10^{\text{Chain 1 PPSD} / 10})$

2. The maximum antenna gain is 8.9dBi; therefore the reduction due to antenna gain is 2dBi, so the limit is 2dBm.



Test mode: IEEE 802.11a mode/ 5745 ~ 5825MHz

Channel	Frequency (MHz)	PPSD (dBm)	Limit (dBm)	Result
Low	5745	1.69	8.00	PASS
Mid	5785	1.46		PASS
High	5825	1.36		PASS

Test mode: IEEE 802.11n HT 20 mode / 5745 ~ 5825MHz

Channel	Frequency (MHz)	Chain 0 PPSD (dBm)	Chain 1 PPSD (dBm)	PPSD (dBm)	Limit (dBm)	Result
Low	5745	5.14	4.13	7.67	6	PASS
Mid	5785	4.58	3.89	7.26		PASS
High	5825	5.70	5.20	8.47		PASS

Test mode: IEEE 802.11n HT 40 mode / 5755 ~ 5795MHz

Channel	Frequency (MHz)	Chain 0 PPSD (dBm)	Chain 1 PPSD (dBm)	PPSD (dBm)	Limit (dBm)	Result
Low	5755	-2.18	-3.40	0.26	6	PASS
High	5795	-2.53	-3.31	0.11		PASS

Test mode: IEEE 802.11n HT 80 MHz mode / 5775MHz

Channel	Frequency (MHz)	Chain 0 PPSD (dBm)	Chain 1 PPSD (dBm)	PPSD (dBm)	Limit (dBm)	Result
Mid	5775	-9.14	-9.26	-6.19	6	PASS

Remark: 1. Total PPSD (dBm) = 10*LOG(10^(Chain 0 PPSD / 10)+10^(Chain 1 PPSD / 10))

2. The maximum antenna gain is 8dBi; therefore the reduction due to antenna gain is 2dBi, so the limit is 6dBm.



Test Plot

IEEE 802.11a mode / 5180 ~ 5240MHz

CH Low

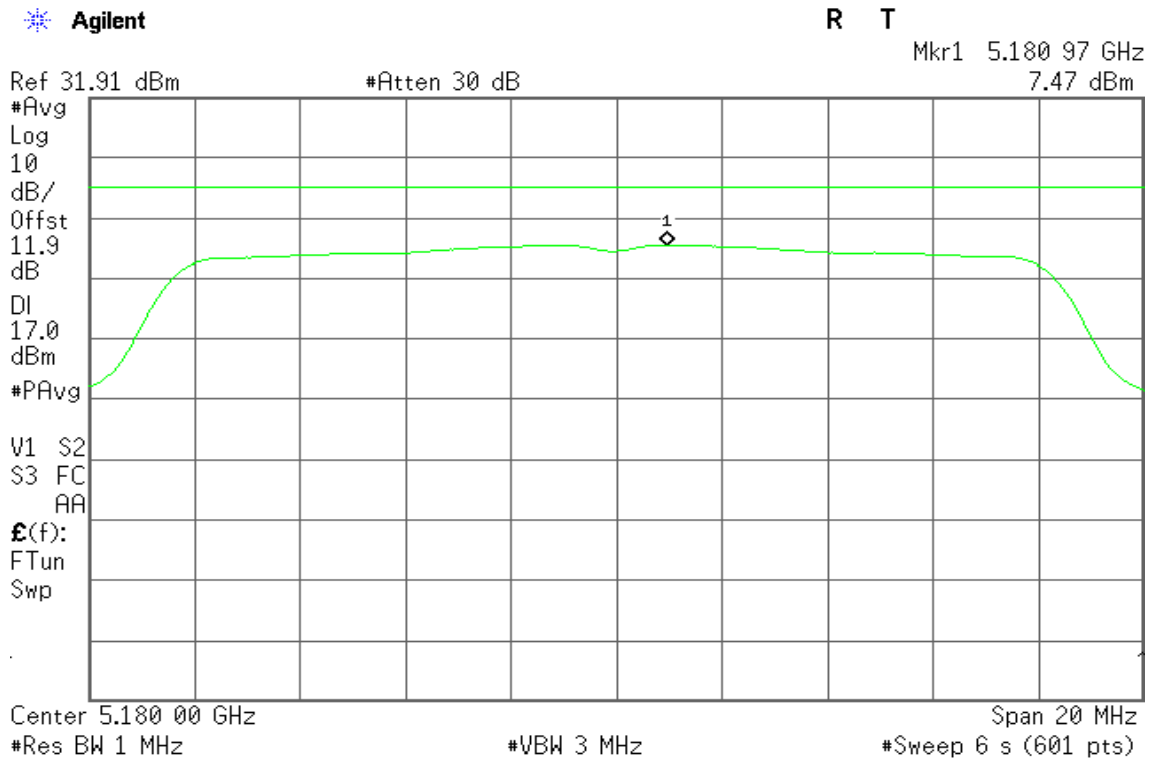

CH Mid

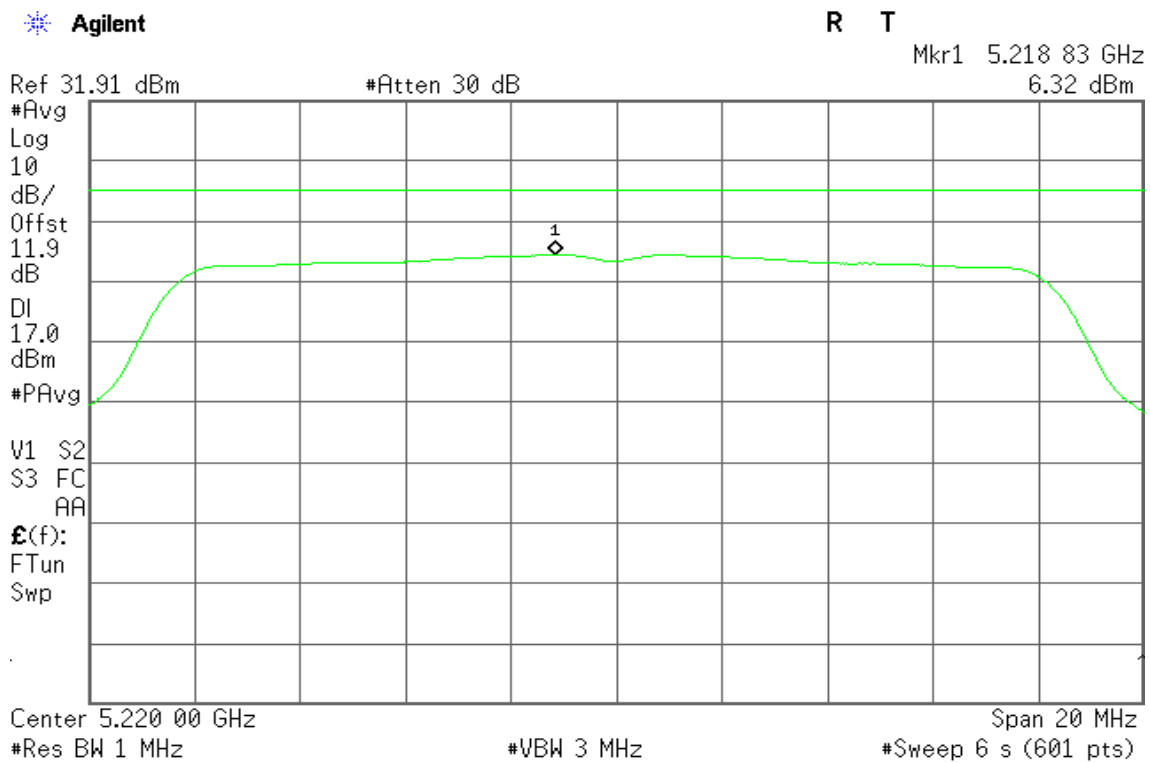



CH High

Agilent

R T

Mkr1 5.238 87 GHz
6.55 dBm

Ref 31.91 dBm

#Atten 30 dB

#Avg
Log
10
dB/
Offst
11.9
dB
DI
17.0
dBm
#PAvg
V1 S2
S3 FC
AA
£(f):
FTun
Swp

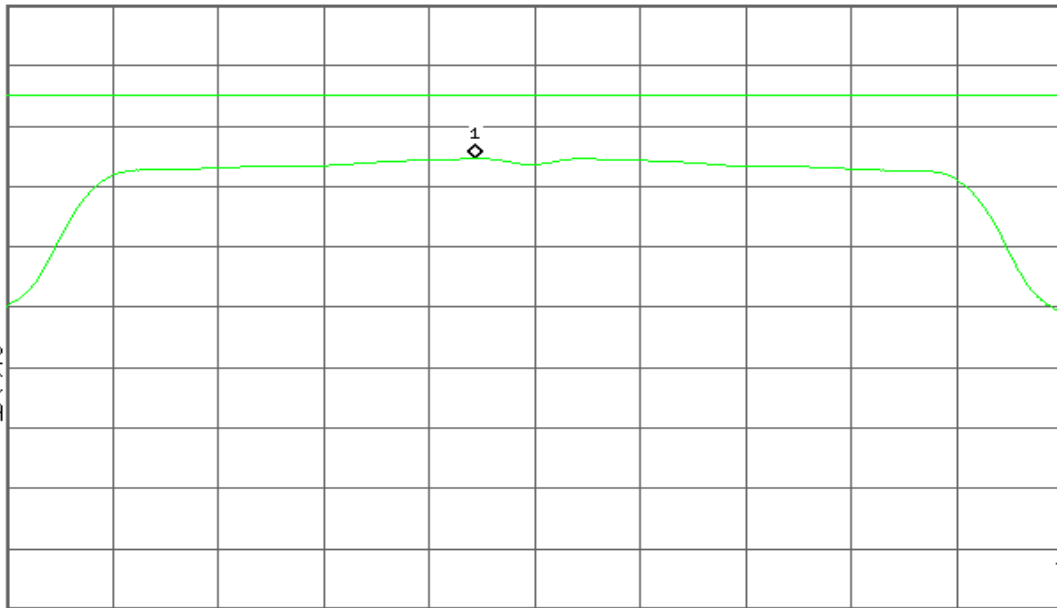

Center 5.240 00 GHz

Span 20 MHz

#Res BW 1 MHz

#VBW 3 MHz

#Sweep 6 s (601 pts)

IEEE 802.11n HT 20 mode / 5180 ~ 5240MHz / Chain 0

CH Low

Agilent

R T

Mkr1 5.180 97 GHz
6.15 dBm

Ref 31.91 dBm

#Atten 30 dB

#Avg
Log
10
dB/
Offst
11.9
dB
DI
17.0
dBm
#PAvg
V1 S2
S3 FC
AA
£(f):
FTun
Swp

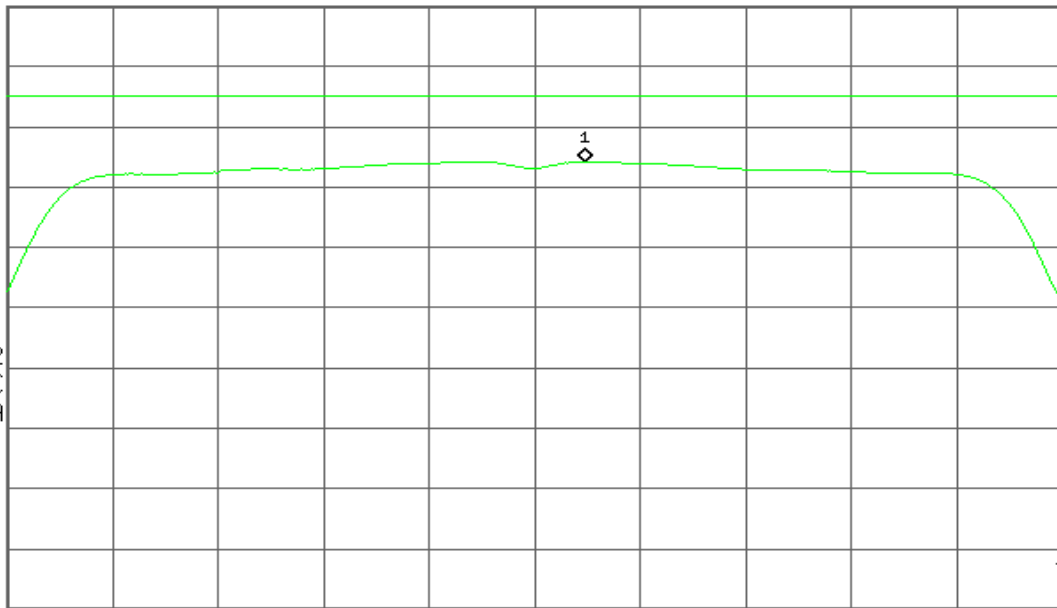

Center 5.180 00 GHz

Span 20 MHz

#Res BW 1 MHz

#VBW 3 MHz

#Sweep 6 s (601 pts)



CH Mid

Agilent

R T

Mkr1 5.218 93 GHz
4.85 dBm

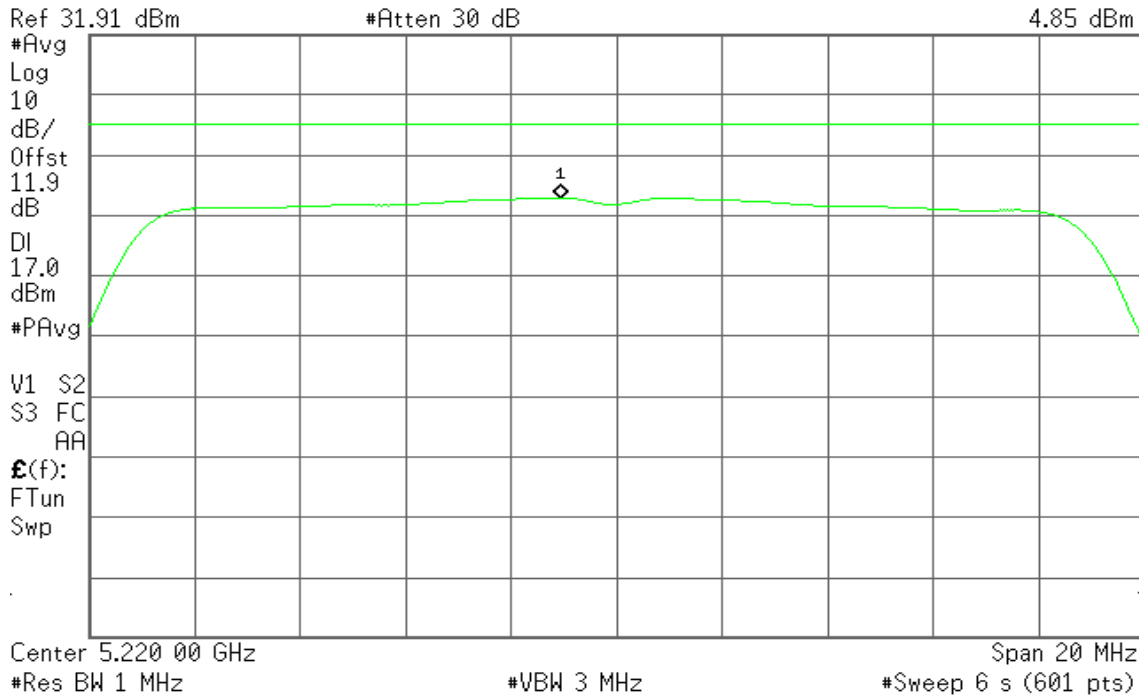

CH High

Agilent

R T

Mkr1 5.238 83 GHz
5.08 dBm

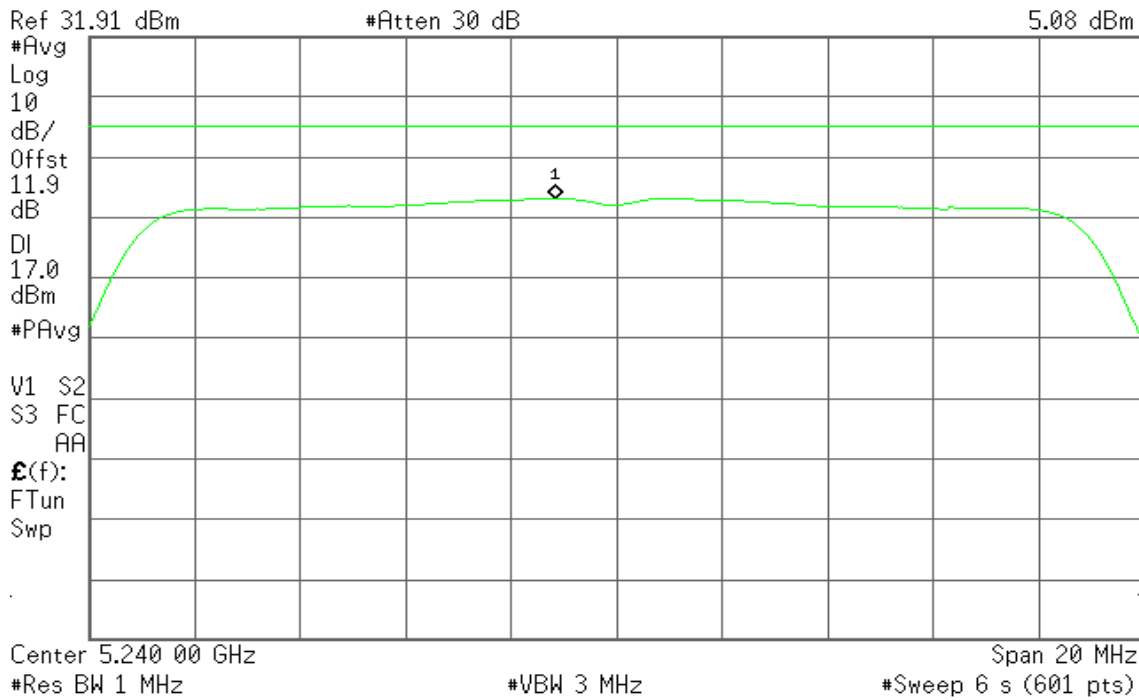



IEEE 802.11n HT 20 mode / 5180 ~ 5240MHz / Chain 1

CH Low

Agilent

R T

Mkr1 5.178 73 GHz
6.45 dBm

Ref 31.91 dBm

#Atten 30 dB

#Avg
Log
10
dB/
Offst
11.9
dB
DI
17.0
dBm
#PAvg
V1 S2
S3 FC
AA
£(f):
FTun
Swp

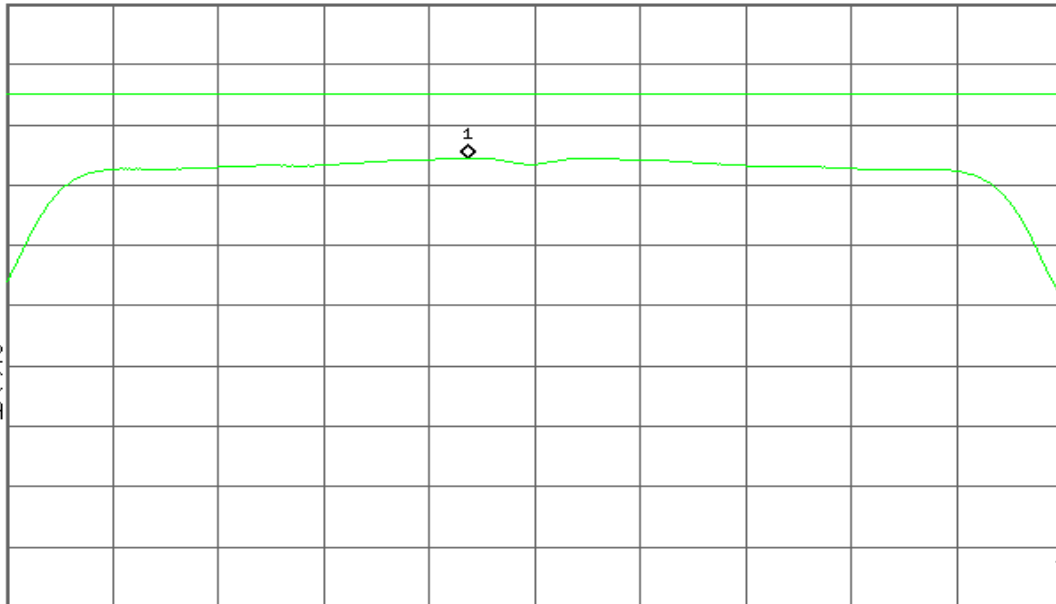

Center 5.180 00 GHz

Span 20 MHz

#Res BW 1 MHz

#VBW 3 MHz

#Sweep 6 s (601 pts)

CH Mid

Agilent

R T

Mkr1 5.218 83 GHz
6.39 dBm

Ref 31.91 dBm

#Atten 30 dB

#Avg
Log
10
dB/
Offst
11.9
dB
DI
17.0
dBm
#PAvg
V1 S2
S3 FC
AA
£(f):
FTun
Swp

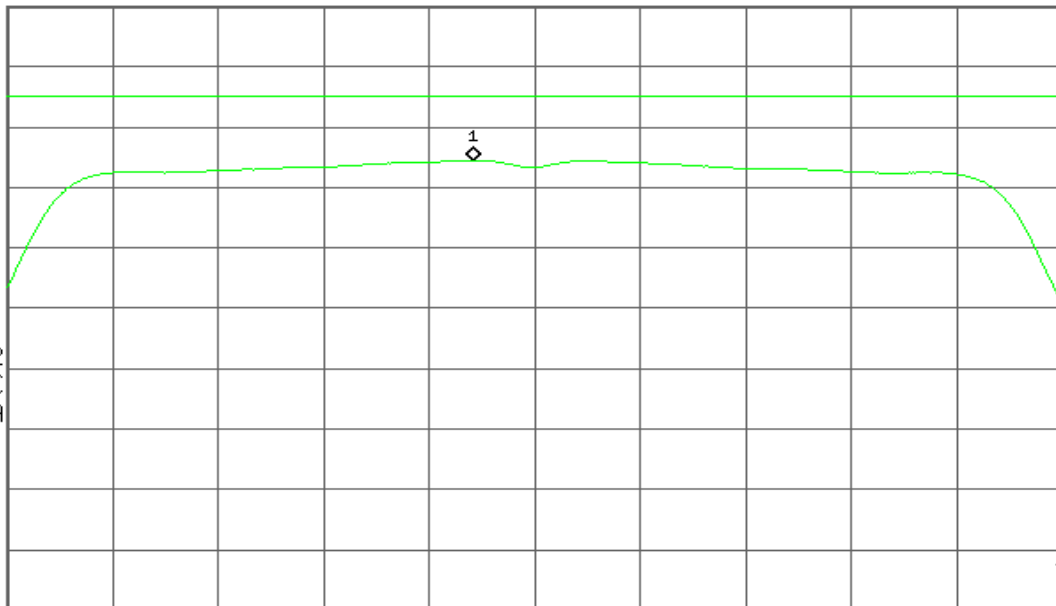

Center 5.220 00 GHz

Span 20 MHz

#Res BW 1 MHz

#VBW 3 MHz

#Sweep 6 s (601 pts)



CH High

Agilent

R T

Mkr1 5.238 87 GHz
6.35 dBm

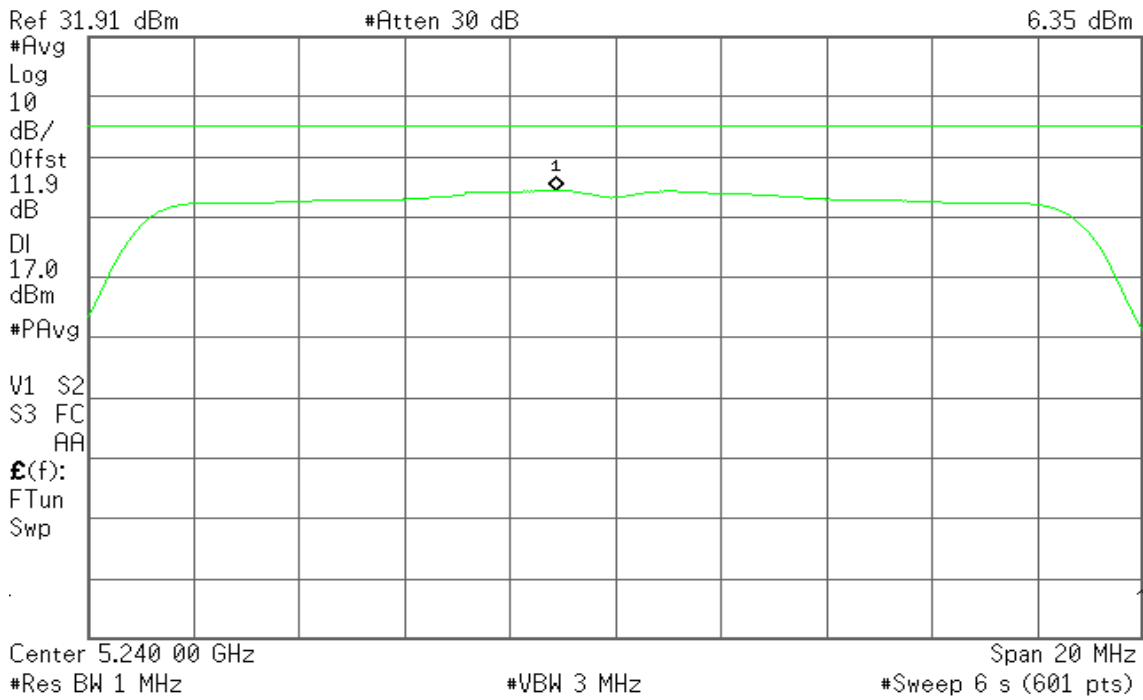

IEEE 802.11n HT 40 mode / 5190 ~ 5230MHz / Chain 0

CH Low

Agilent

R T

Mkr1 5.187 67 GHz
-0.89 dBm

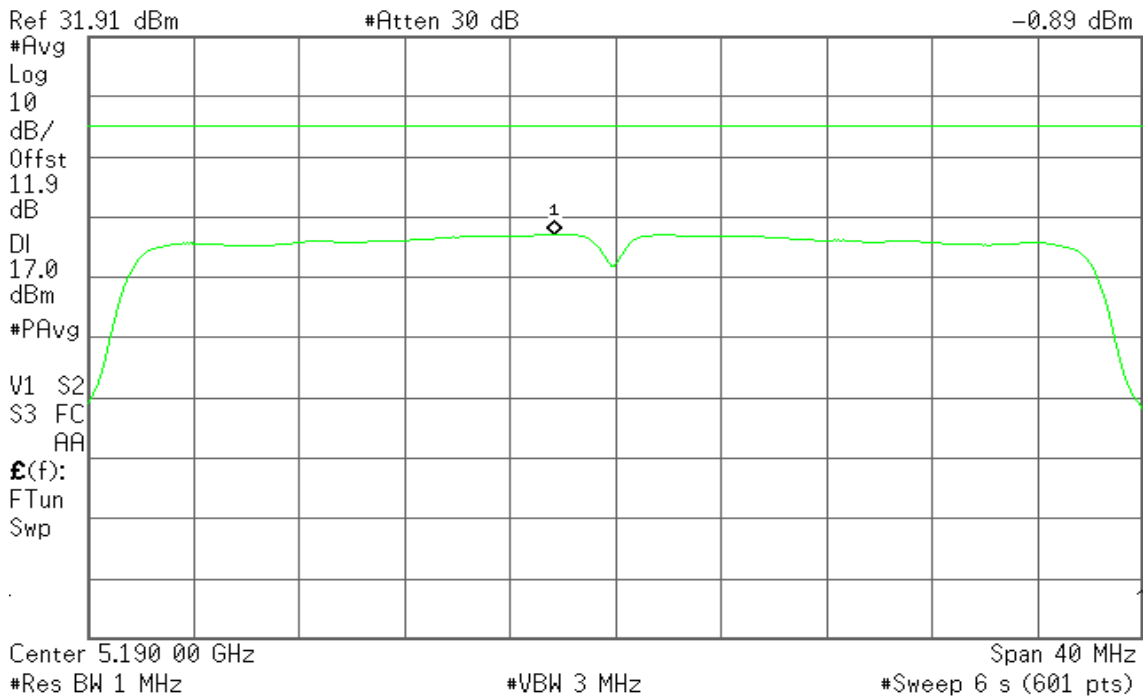



CH High

Agilent

R T

Mkr1 5.227 67 GHz
0.56 dBm

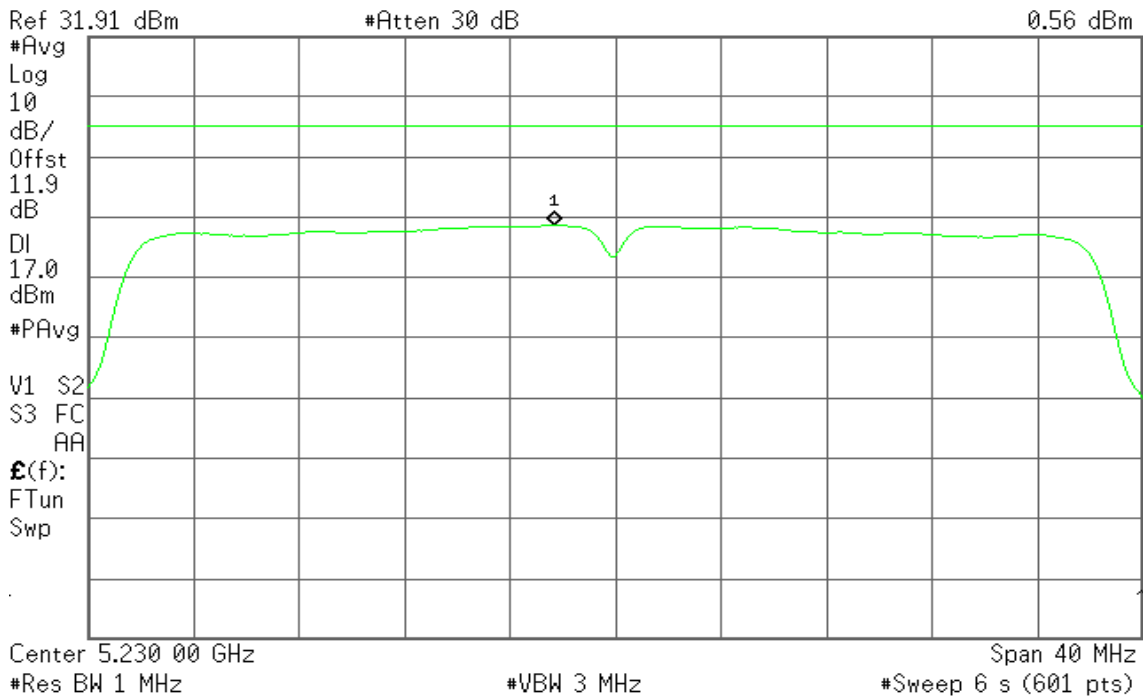

IEEE 802.11n HT 40 mode / 5190 ~ 5230MHz / Chain 1

CH Low

Agilent

R T

Mkr1 5.187 60 GHz
-2.05 dBm

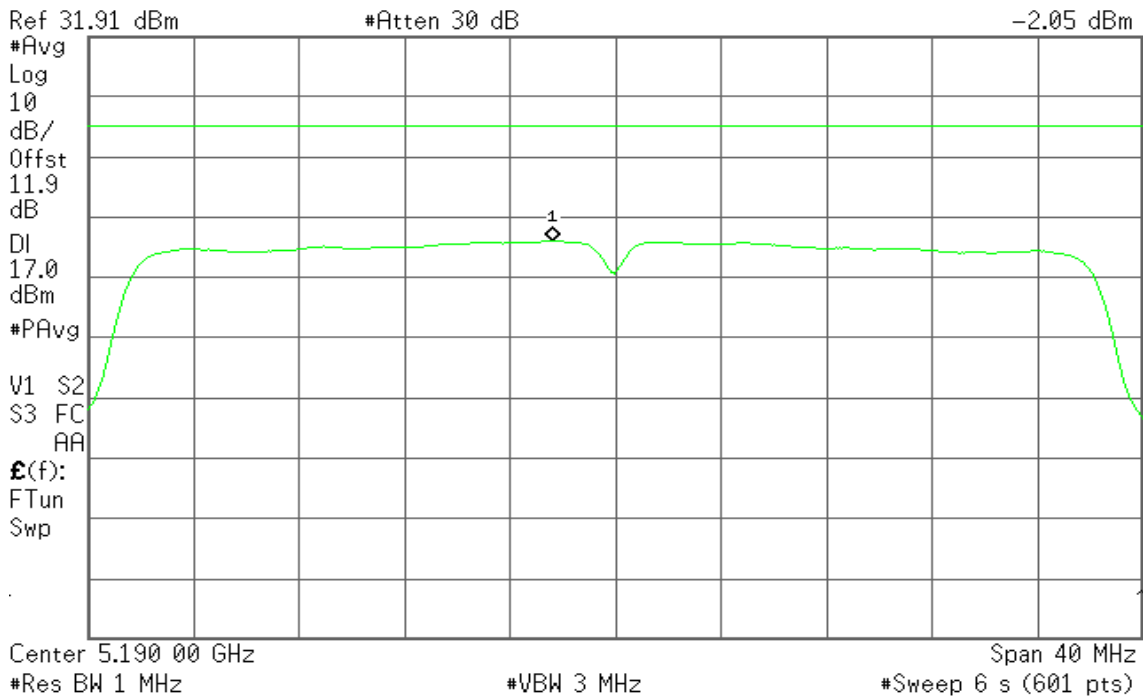



CH High

Agilent

R T

Mkr1 5.227 67 GHz
0.39 dBm

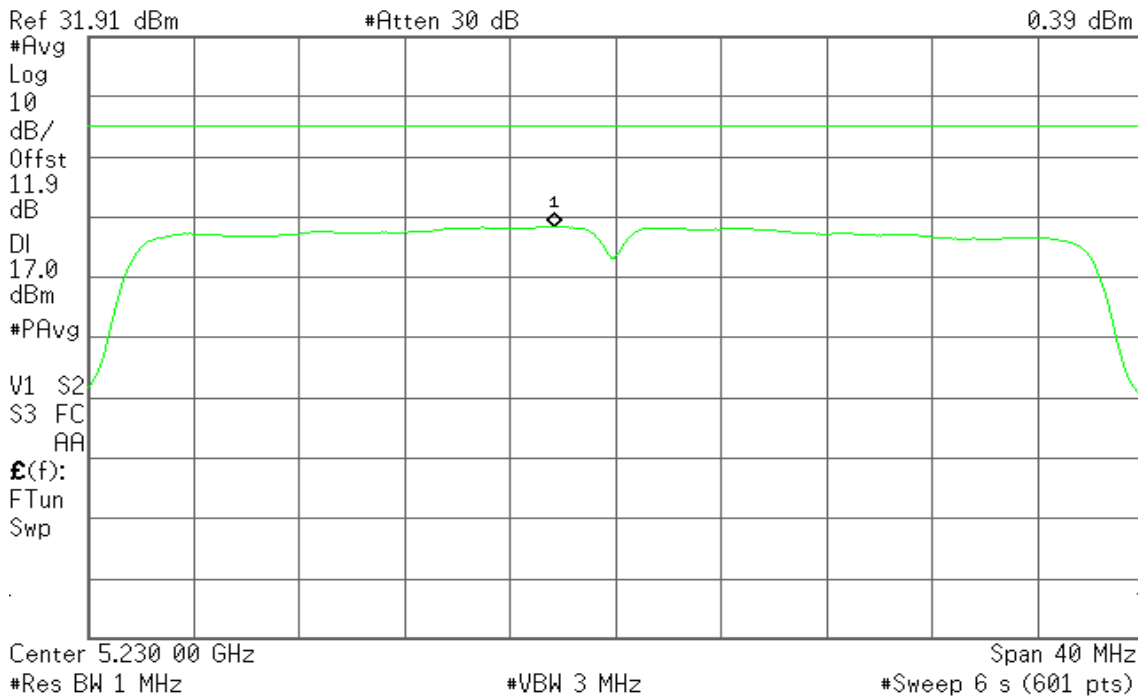

IEEE 802.11n HT 80 MHz mode / 5210MHz / Chain 0

CH Mid

Agilent

R T

Mkr1 5.206 13 GHz
-7.93 dBm

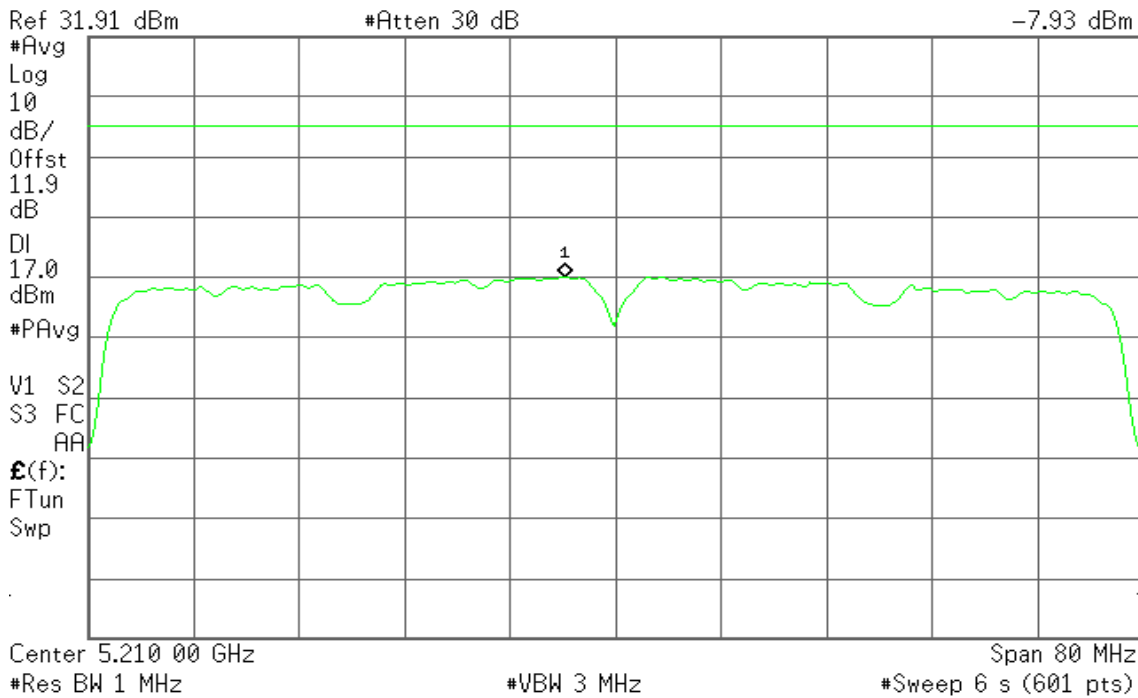



IEEE 802.11n HT 80 MHz mode / 5210MHz / Chain 1

CH Mid

Agilent

R T

Mkr1 5.206 13 GHz
-8.74 dBm

Ref 31.91 dBm

#Atten 30 dB

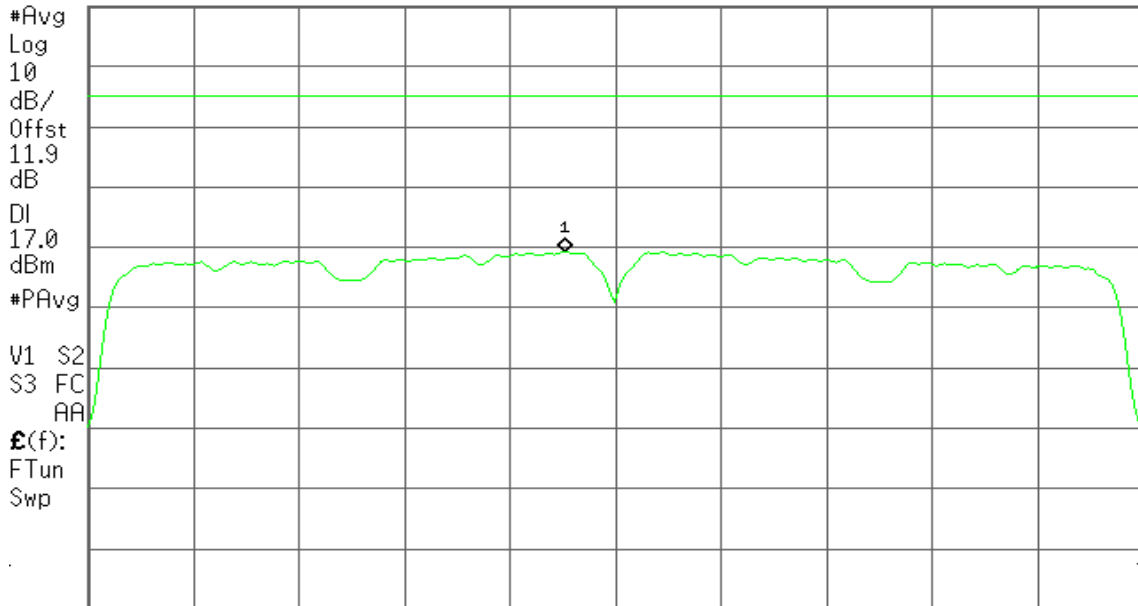

Center 5.210 00 GHz

#Res BW 1 MHz

#VBW 3 MHz

Span 80 MHz

#Sweep 6 s (601 pts)

IEEE 802.11a mode / 5745 ~ 5825MHz

CH Low

Agilent

R T

Mkr1 5.744 07 GHz
1.69 dBm

Ref 33.1 dBm

#Atten 30 dB

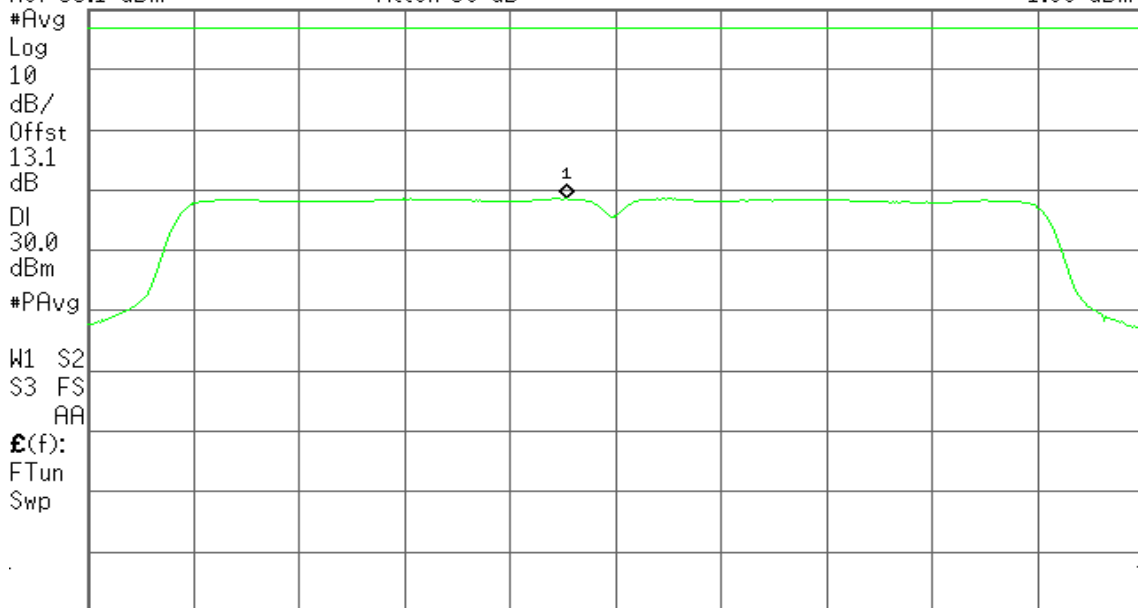

Center 5.745 00 GHz

#Res BW 510 kHz

#VBW 1.6 MHz

Span 20 MHz

#Sweep 6 s (601 pts)



CH Mid

Agilent

R T

Mkr1 5.781 00 GHz
1.46 dBm

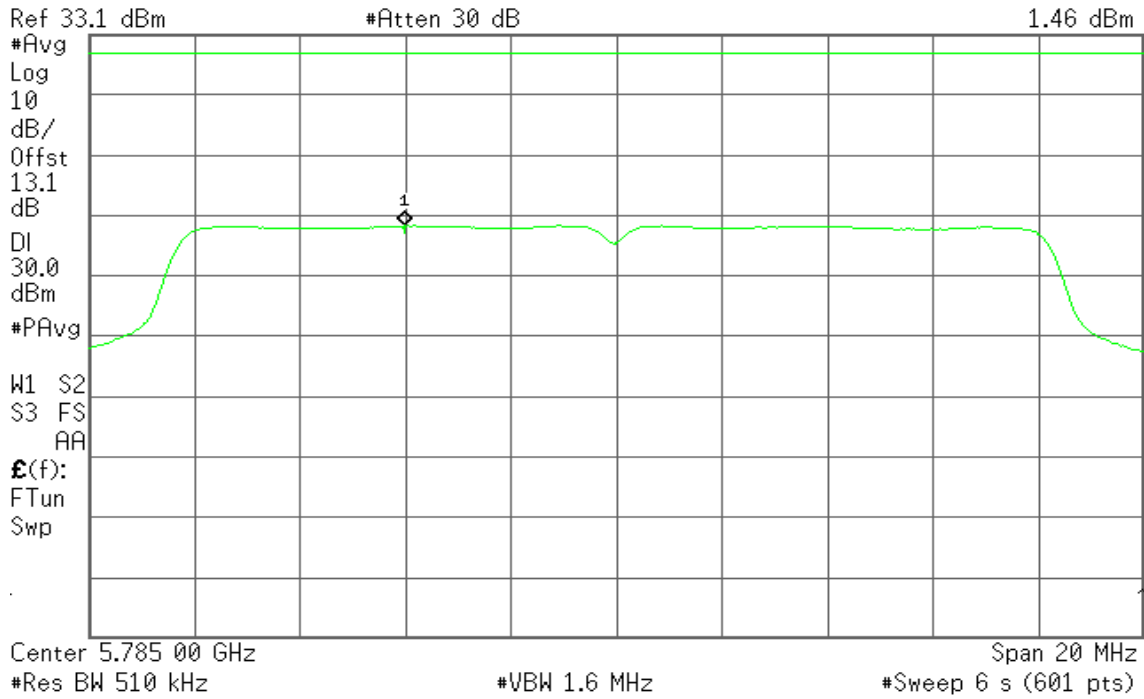

CH High

Agilent

R T

Mkr1 5.826 03 GHz
1.36 dBm

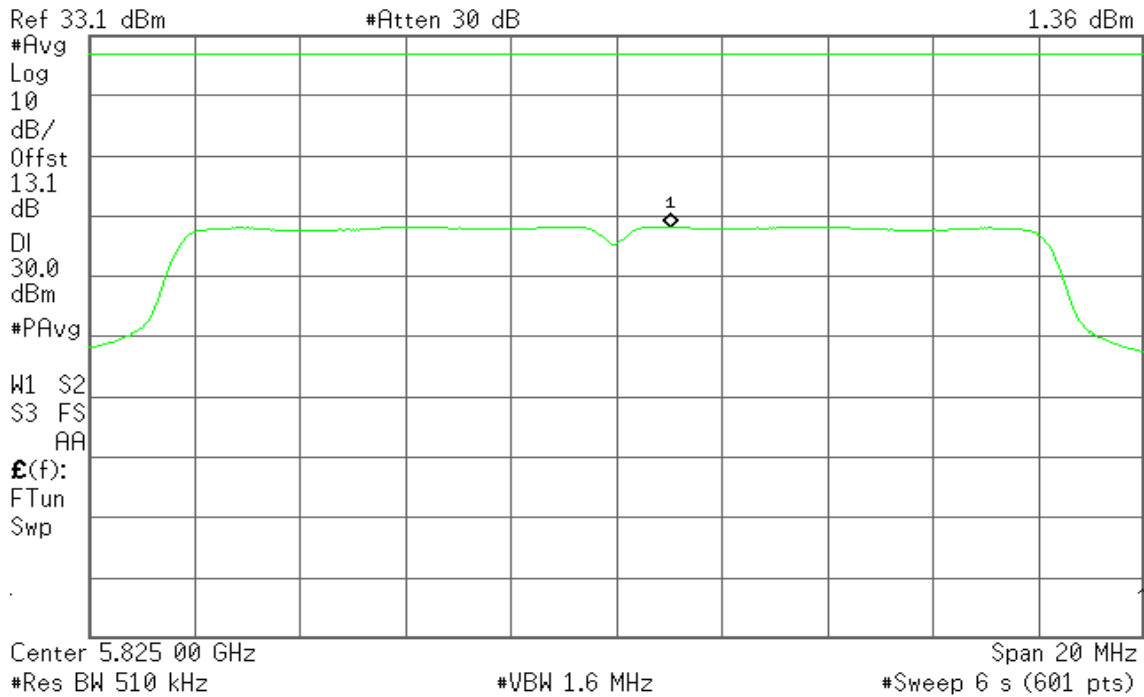



IEEE 802.11n HT 20 mode / 5745 ~ 5825MHz / Chain 0

CH Low

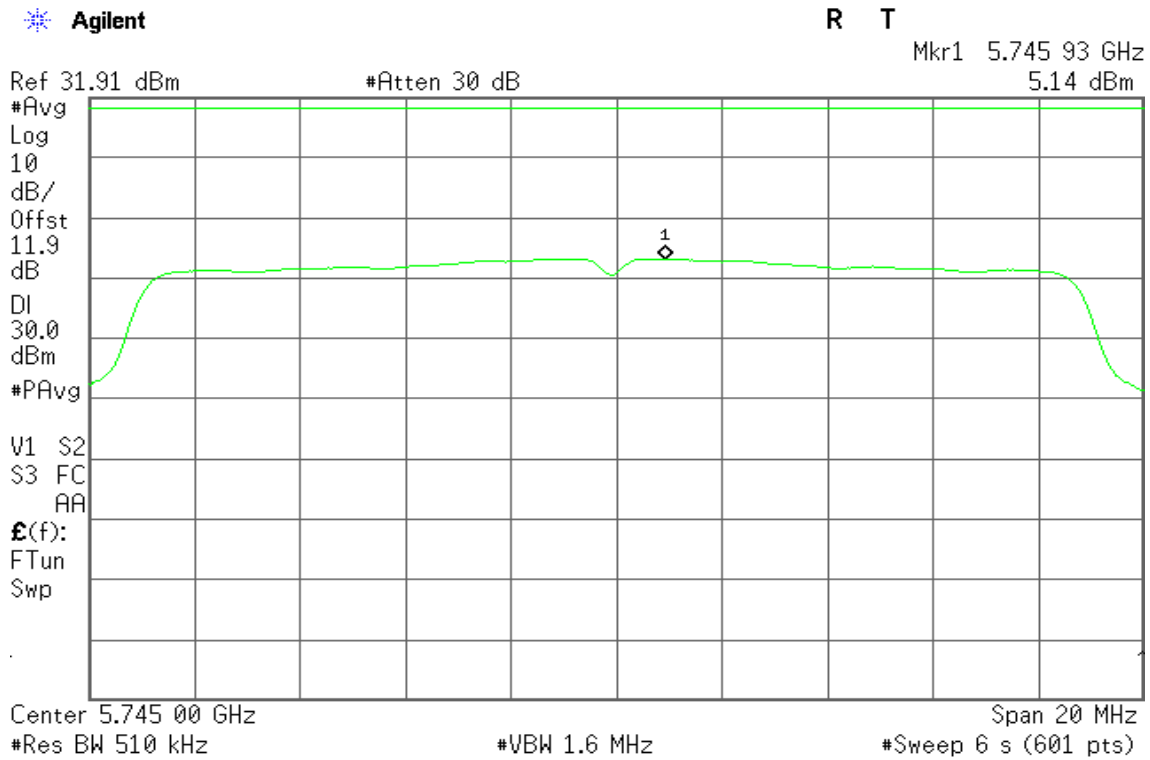

CH Mid

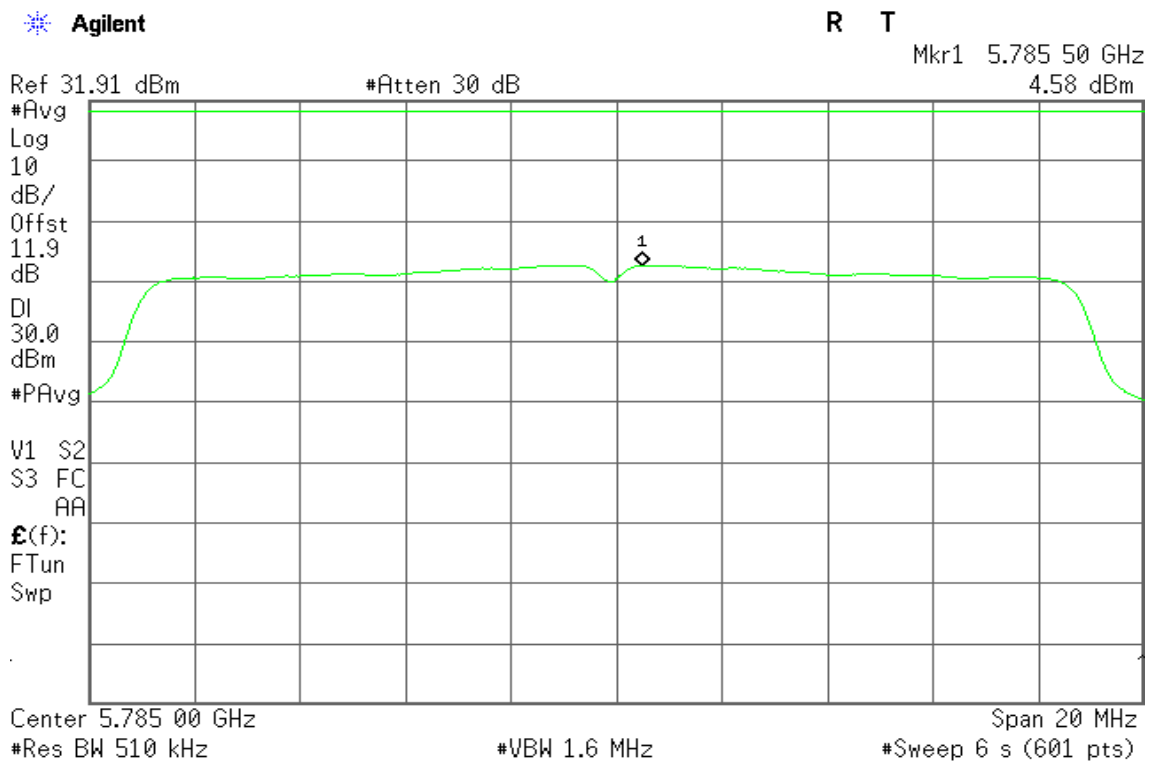



CH High

Agilent

R T

Mkr1 5.825 63 GHz
5.70 dBm

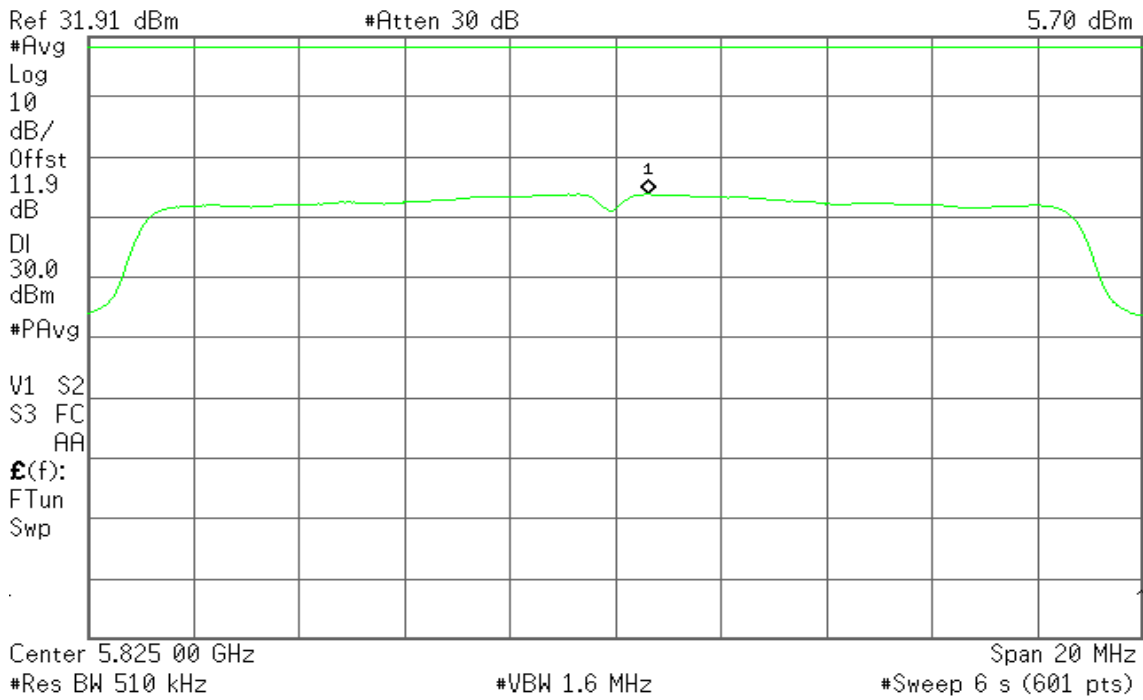

IEEE 802.11n HT 20 mode / 5745 ~ 5825MHz / Chain 1

CH Low

Agilent

R T

Mkr1 5.743 87 GHz
4.13 dBm

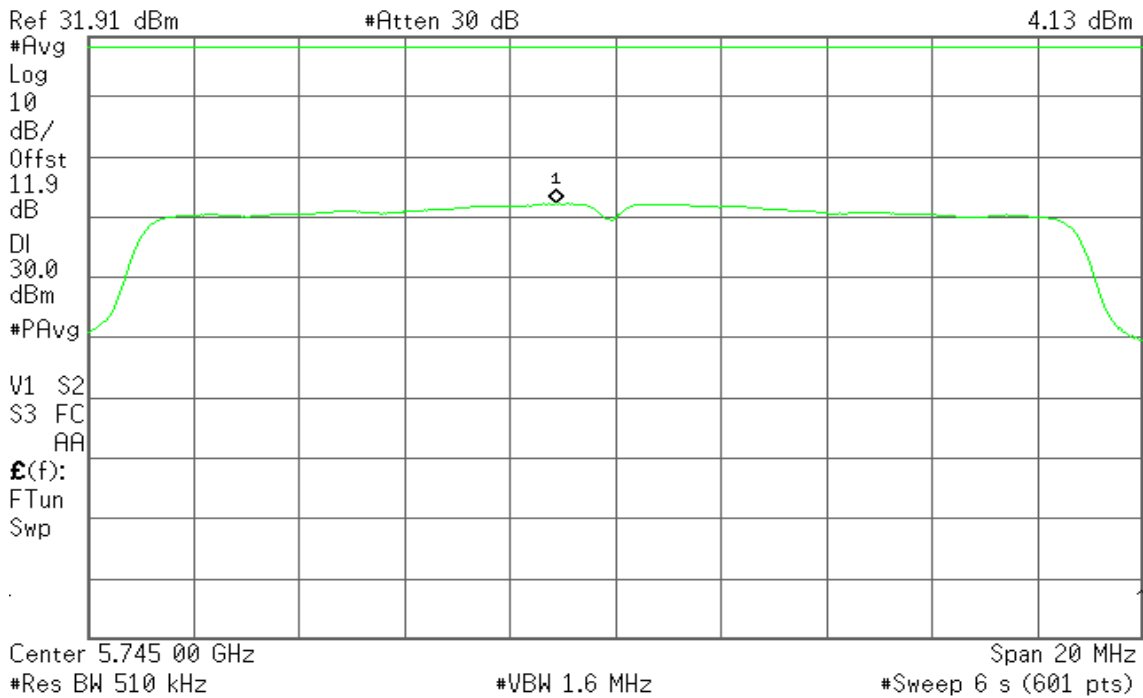



CH Mid

Agilent

R T

Mkr1 5.785 53 GHz
3.89 dBm

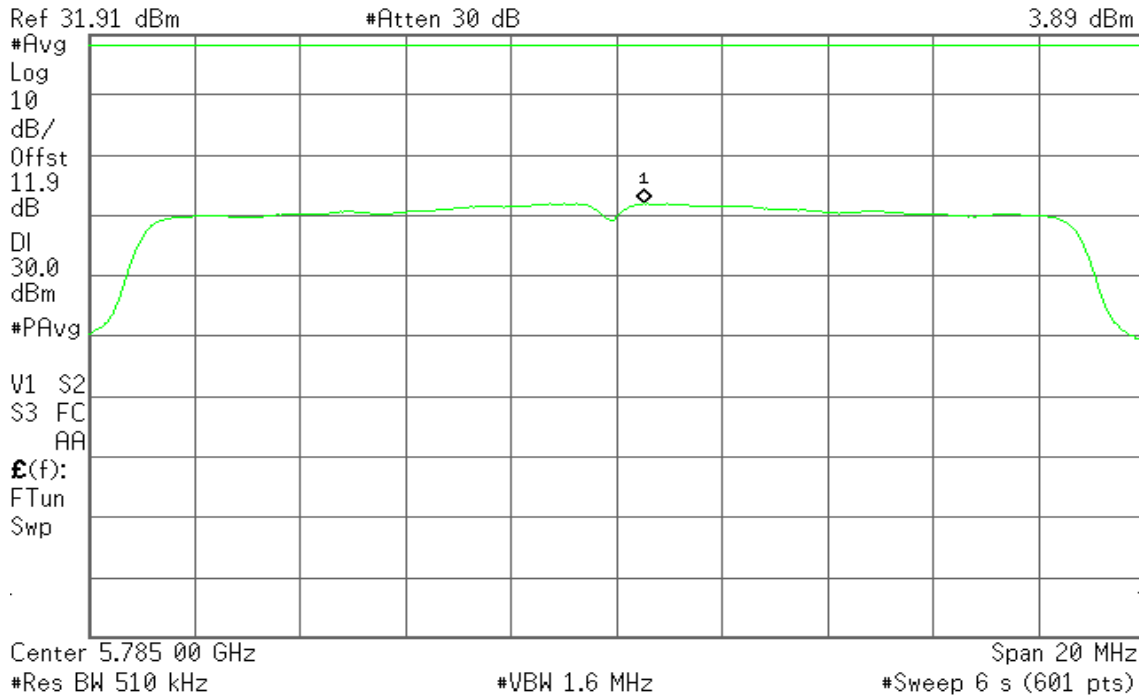

CH High

Agilent

R T

Mkr1 5.824 20 GHz
5.20 dBm

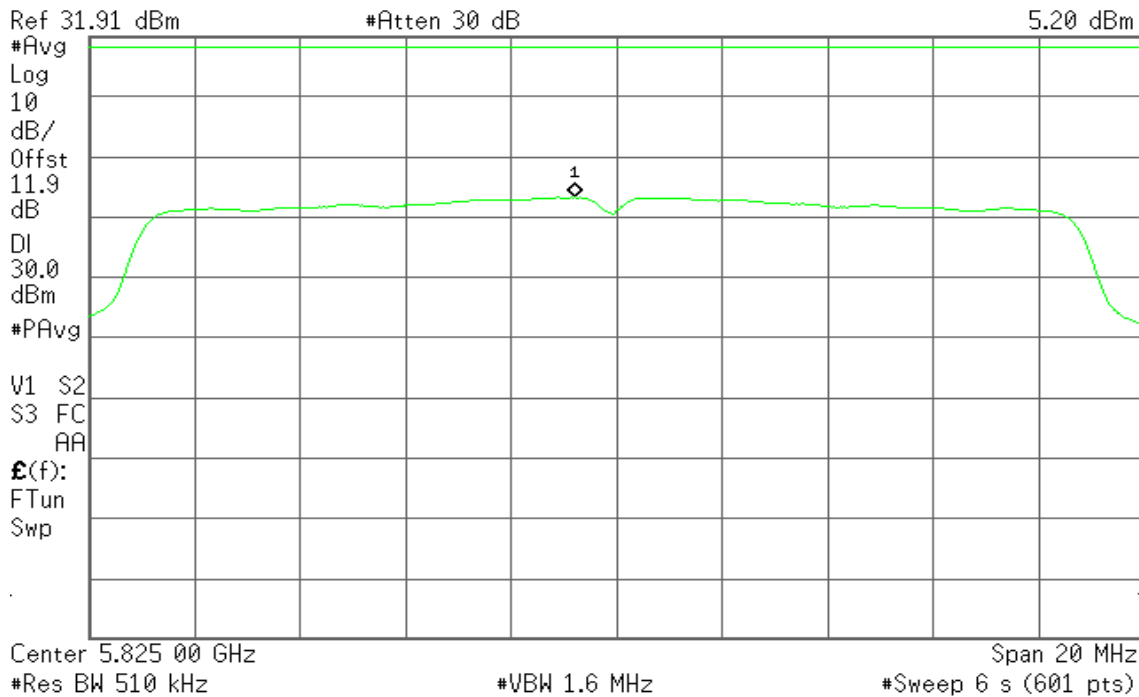



IEEE 802.11n HT 40 mode / 5755 ~ 5795MHz / Chain 0

CH Low

Agilent

R T

Mkr1 5.752 40 GHz
-2.18 dBm

Ref 31.91 dBm

#Atten 30 dB

#Avg
Log
10
dB/
Offst
11.9
dB
DI
30.0
dBm
#PAvg
V1 S2
S3 FC
AA
£(f):
FTun
Swp

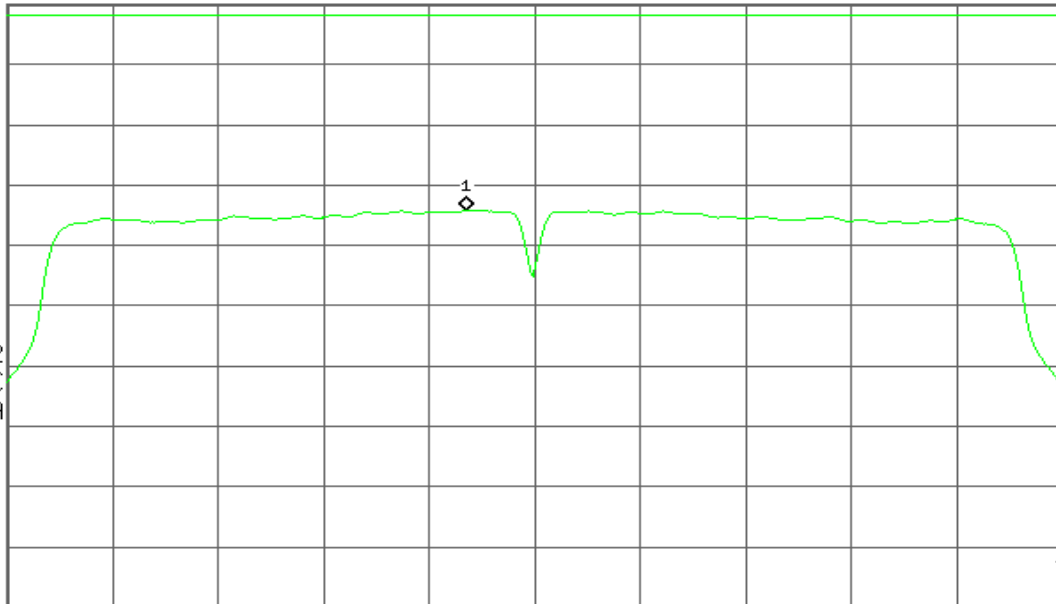

Center 5.755 00 GHz

#Res BW 510 kHz

#VBW 1.6 MHz

Span 40 MHz

#Sweep 6 s (601 pts)

CH High

Agilent

R T

Mkr1 5.792 47 GHz
-2.53 dBm

Ref 31.91 dBm

#Atten 30 dB

#Avg
Log
10
dB/
Offst
11.9
dB
DI
30.0
dBm
#PAvg
V1 S2
S3 FC
AA
£(f):
FTun
Swp

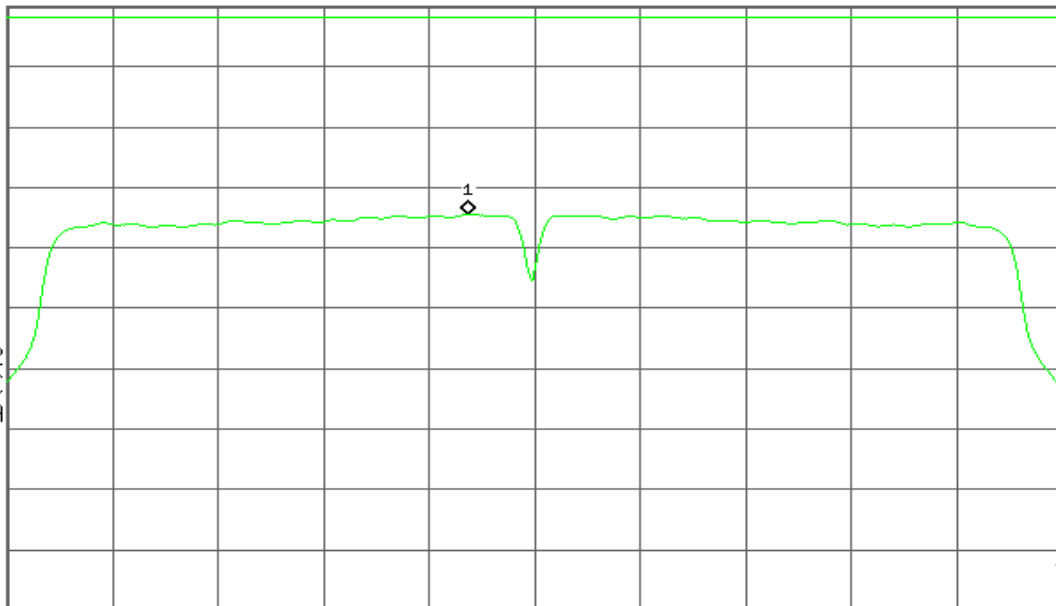

Center 5.795 00 GHz

#Res BW 510 kHz

#VBW 1.6 MHz

Span 40 MHz

#Sweep 6 s (601 pts)



IEEE 802.11n HT 40 mode / 5755 ~ 5795MHz / Chain 1

CH Low

Agilent

R T

Mkr1 5.752 47 GHz
-3.40 dBm

Ref 31.91 dBm

#Atten 30 dB

#Avg
Log
10
dB/
Offst
11.9
dB
DI
30.0
dBm
#PAvg
V1 S2
S3 FC
AA
£(f):
FTun
Swp

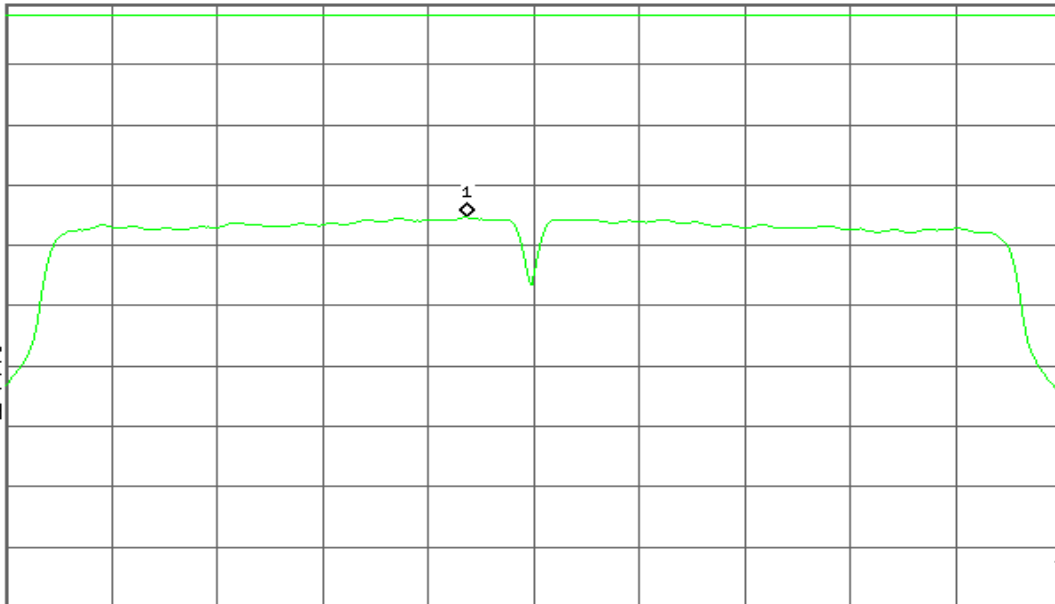

Center 5.755 00 GHz

#Res BW 510 kHz

#VBW 1.6 MHz

Span 40 MHz

#Sweep 6 s (601 pts)

CH High

Agilent

R T

Mkr1 5.792 40 GHz
-3.31 dBm

Ref 31.91 dBm

#Atten 30 dB

#Avg
Log
10
dB/
Offst
11.9
dB
DI
30.0
dBm
#PAvg
V1 S2
S3 FC
AA
£(f):
FTun
Swp

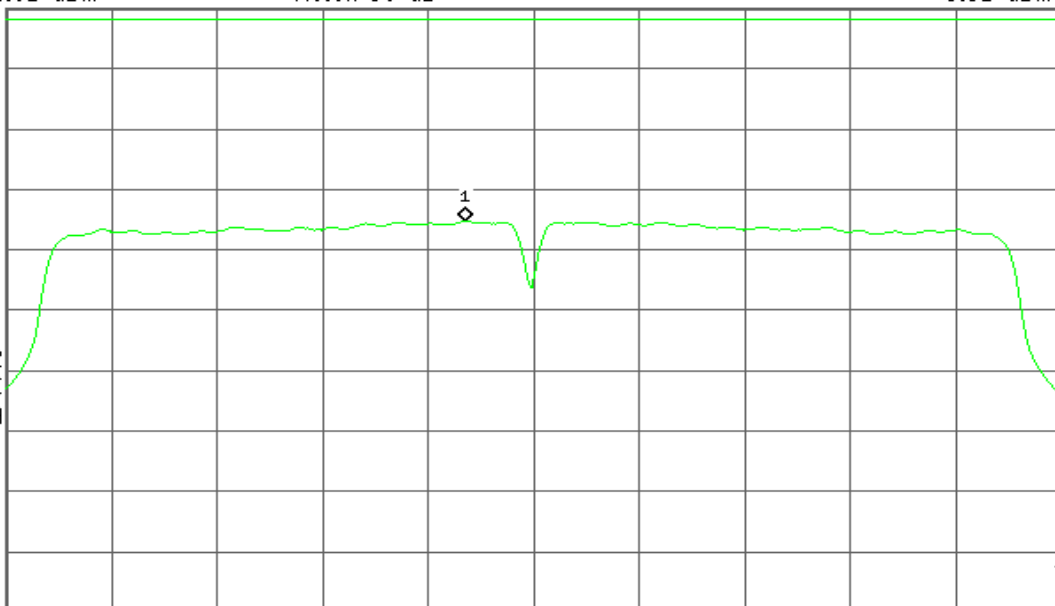

Center 5.795 00 GHz

#Res BW 510 kHz

#VBW 1.6 MHz

Span 40 MHz

#Sweep 6 s (601 pts)



IEEE 802.11n HT 80 MHz mode / 5775MHz / Chain 0

CH Mid

Agilent

R T

Mkr1 5.778 60 GHz
-9.14 dBm

Ref 31.91 dBm

#Atten 30 dB

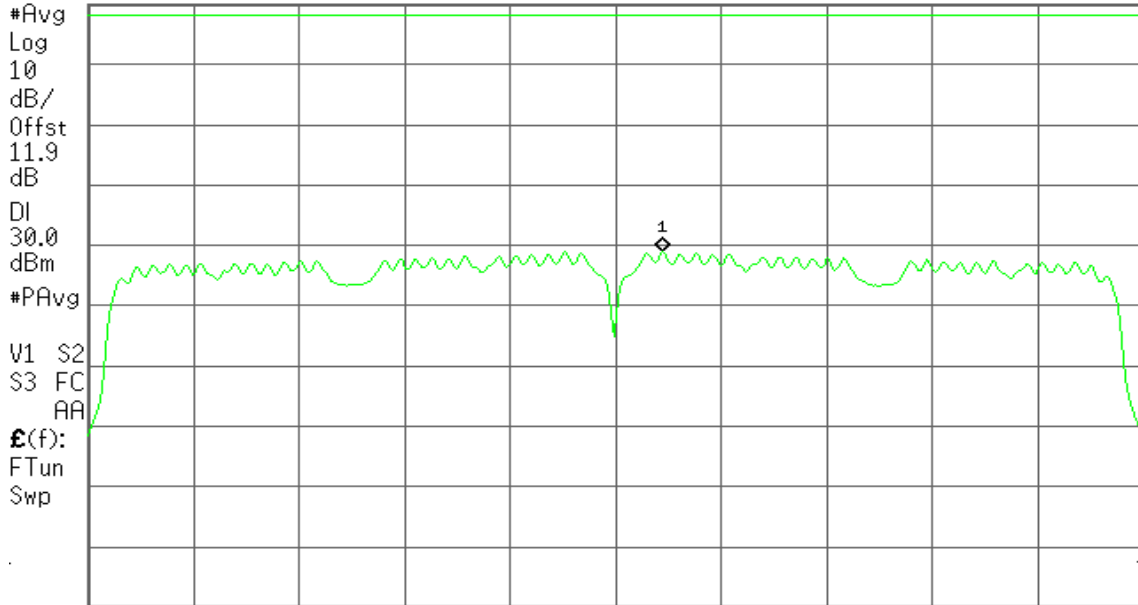

Center 5.775 00 GHz

#Res BW 510 kHz

#VBW 1.6 MHz

Span 80 MHz

#Sweep 6 s (601 pts)

IEEE 802.11n HT 80 MHz mode / 5775MHz / Chain 1

CH Mid

Agilent

R T

Mkr1 5.771 13 GHz
-9.26 dBm

Ref 31.91 dBm

#Atten 30 dB

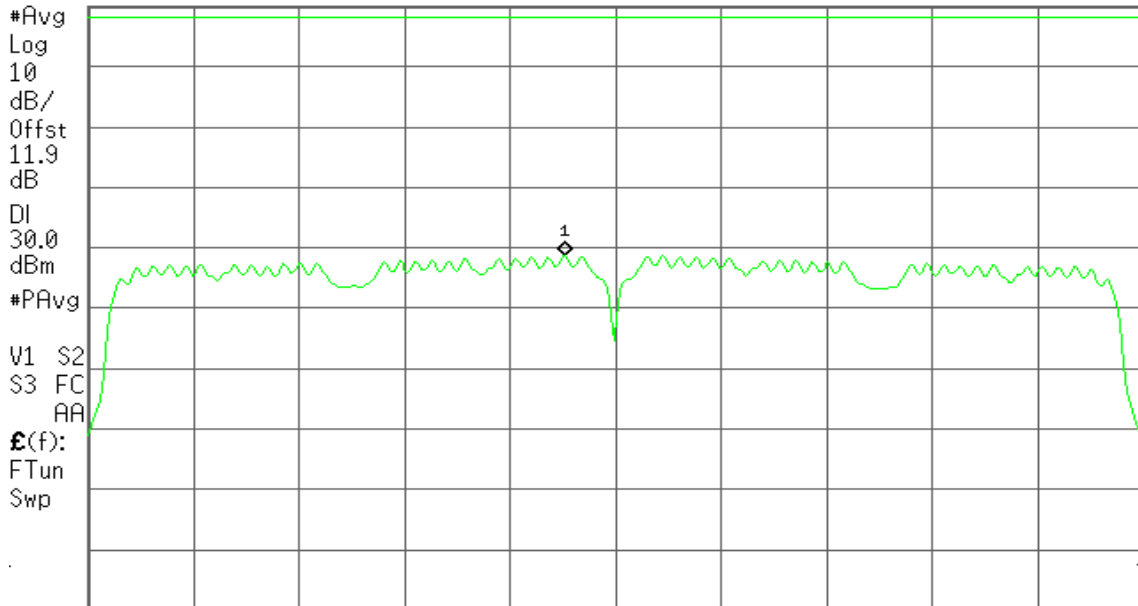

Center 5.775 00 GHz

#Res BW 510 kHz

#VBW 1.6 MHz

Span 80 MHz

#Sweep 6 s (601 pts)



7.5 RADIATED UNDESIRABLE EMISSION

1. According to §15.209(a), except as provided elsewhere in this Subpart, the emissions from an intentional radiator shall not exceed the field strength levels specified in the following table:

Frequency (MHz)	Field Strength ($\mu\text{V}/\text{m}$)	Measurement Distance (m)
0.009 - 0.490	2400/F(kHz)	300
0.490 - 1.705	24000/F(kHz)	30
1.705 – 30.0	30	30
30-88	100	3
88-216	150	3
216-960	200	3
Above 960	500	3

Remark: Except as provided in paragraph (g), fundamental emissions from intentional radiators operating under this Section shall not be located in the frequency bands 54-72 MHz, 76-88 MHz, 174-216 MHz or 470-806 MHz. However, operation within these frequency bands is permitted under other sections of this Part, e.g., Sections 15.231 and 15.241.

2. In the emission table above, the tighter limit applies at the band edges.

Frequency (MHz)	Field Strength ($\mu\text{V}/\text{m}$ at 3-meter)	Field Strength (dB $\mu\text{V}/\text{m}$ at 3-meter)
0.009 - 0.490	2400/F(kHz) +80	20LOG((2400/F(kHz))+80)
0.490 - 1.705	24000/F(kHz) +40	20LOG((24000/F(kHz))+40)
1.705 – 30.0	30	69.54
30-88	100	40
88-216	150	43.5
216-960	200	46
Above 960	500	54



Test Configuration

9kHz ~ 30MHz

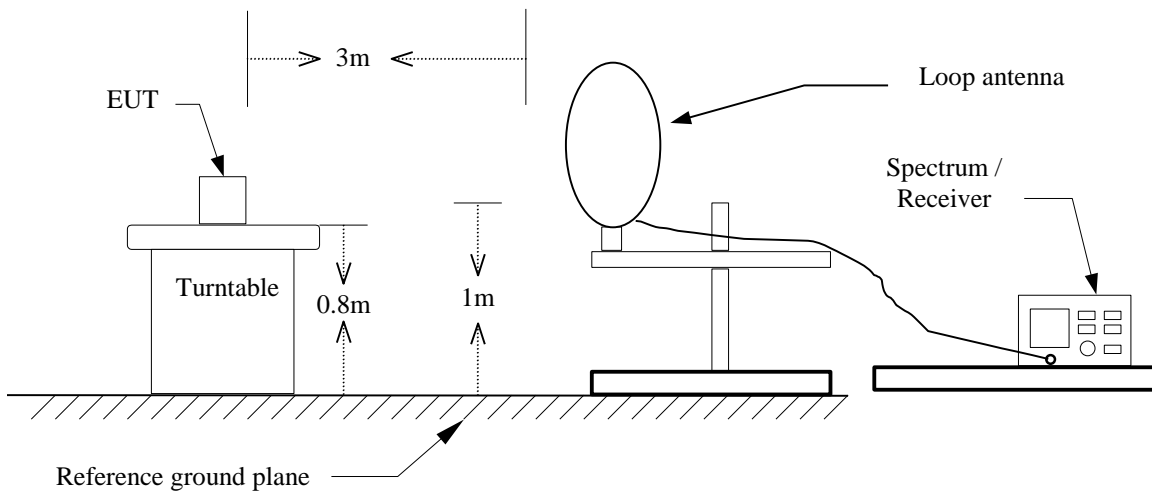

30MHz ~ 1GHz

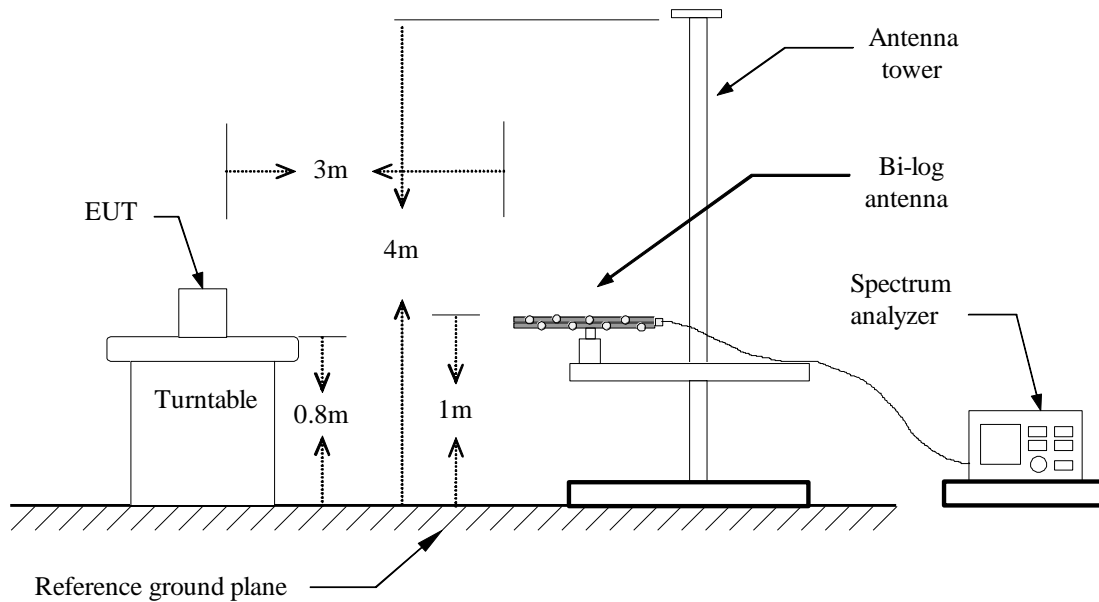



Above 1 GHz

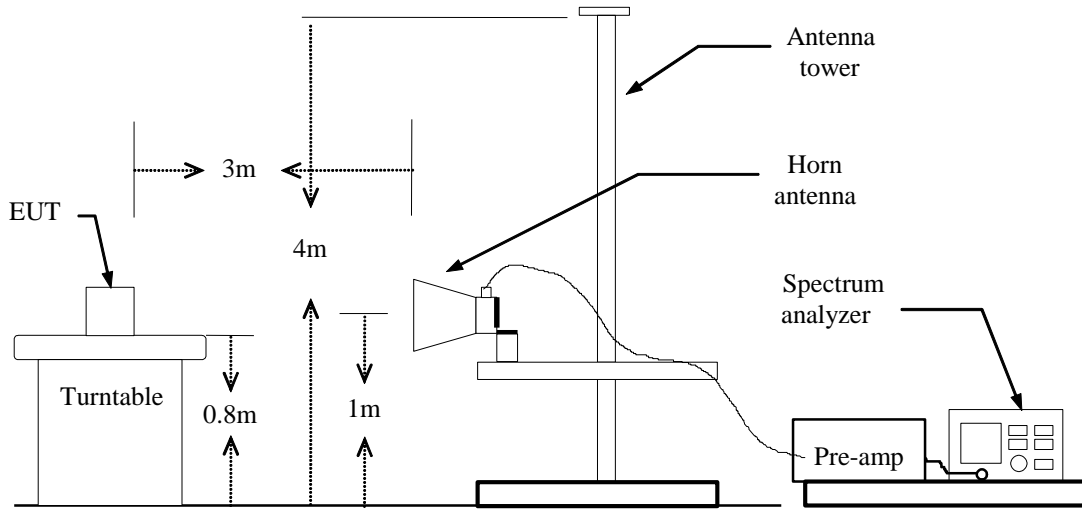



TEST PROCEDURE

1. The EUT is placed on a turntable, which is 0.8m above ground plane.
2. The turntable shall be rotated for 360 degrees to determine the position of maximum emission level.
3. EUT is set 3m away from the receiving antenna, which is varied from 1m to 4m to find out the highest emissions.
4. Maximum procedure was performed on the six highest emissions to ensure EUT compliance.
5. And also, each emission was to be maximized by changing the polarization of receiving antenna both horizontal and vertical.
6. Set the spectrum analyzer in the following setting as:

Below 1GHz:

RBW=100kHz / VBW=300kHz / Sweep=AUTO

Above 1GHz:

(a) PEAK: RBW=VBW=1MHz / Sweep=AUTO

(b) AVERAGE: RBW=1MHz / VBW=10Hz / Sweep=AUTO

7. Repeat above procedures until the measurements for all frequencies are complete.

**For printed Antenna****Below 1 GHz****Operation Mode:** Normal Link**Test Date:** December 29, 2014**Temperature:** 27°C**Tested by:** Andy Shi**Humidity:** 53% RH**Polarity:** Ver. / Hor.

Frequency (MHz)	Reading (dBuV)	Correction Factor (dB/m)	Result (dBuV/m)	Limit (dBuV/m)	Margin (dB)	Remark	Ant.Pol. (H/V)
98.8700	39.35	-21.19	18.16	43.50	-25.34	peak	V
280.2600	34.22	-16.76	17.46	46.00	-28.54	peak	V
456.8000	28.83	-12.55	16.28	46.00	-29.72	peak	V
665.3500	31.64	-9.15	22.49	46.00	-23.51	peak	V
719.6700	26.09	-8.43	17.66	46.00	-28.34	peak	V
951.5000	25.06	-5.46	19.60	46.00	-26.40	peak	V
120.2100	33.43	-17.37	16.06	43.50	-27.44	peak	H
239.5200	35.19	-18.62	16.57	46.00	-29.43	peak	H
335.5500	35.79	-15.54	20.25	46.00	-25.75	peak	H
455.8300	28.07	-12.56	15.51	46.00	-30.49	peak	H
665.3500	40.63	-9.15	31.48	46.00	-14.52	peak	H
832.1900	25.46	-6.99	18.47	46.00	-27.53	peak	H

Remark:

1. No emission found between lowest internal used/generated frequency to 30MHz (9kHz~30MHz)
2. Radiated emissions measured in frequency range from 30 MHz to 1000MHz were made with an instrument using peak/quasi-peak detector mode.
3. Quasi-peak test would be performed if the peak result were greater than the quasi-peak limit.
4. Data of measurement within this frequency range shown " --- " in the table above means the reading of emissions are attenuated more than 20dB below the permissible limits or the field strength is too small to be measured.
5. Measurements above show only up to 6 maximum emissions noted, or would be lesser, with " N/A " remark, if no specific emissions from the EUT are recorded (ie: margin>20dB from the applicable limit) and considered that's already beyond the background noise floor.
6. Margin (dB) = Remark result (dBuV/m) – Quasi-peak limit (dBuV/m).



Above 1 GHz

Operation Mode: Tx / IEEE 802.11a mode / 5180 ~ 5240MHz / CH Low **Test Date:** December 30, 2014

Temperature: 27°C **Tested by:** Andy Shi

Humidity: 53% RH **Polarity:** Ver. / Hor.

Frequency (MHz)	Reading (dBuV)	Correction (dB/m)	Result (dBuV/m)	Limit (dBuV/m)	Margin (dB)	Remark	Ant.Pol. (H/V)
1924.000	57.12	-5.28	51.84	74.00	-22.16	peak	V
N/A							
3779.000	52.41	0.28	52.69	74.00	-21.31	peak	H
N/A							

Remark:

1. Measuring frequencies from 1 GHz to the 10th harmonic of highest fundamental frequency.
2. Radiated emissions measured in frequency above 1000MHz were made with an instrument using peak/average detector mode.
3. Average test would be performed if the peak result were greater than the average limit.
4. Data of measurement within this frequency range shown “ --- ” in the table above means the reading of emissions are attenuated more than 20dB below the permissible limits or the field strength is too small to be measured.
5. Measurements above show only up to 6 maximum emissions noted, or would be lesser, with “ N/A ” remark, if no specific emissions from the EUT are recorded (ie: margin>20dB from the applicable limit) and considered that's already beyond the background noise floor.
6. $Margin (dB) = Remark\ result (dBuV/m) - Average\ limit (dBuV/m)$.



Operation Mode: Tx / IEEE 802.11a mode / 5180 ~ 5240MHz /CH Mid **Test Date:** December 30, 2014
Temperature: 27°C **Tested by:** Andy Shi
Humidity: 53% RH **Polarity:** Ver. / Hor.

Frequency (MHz)	Reading (dBuV)	Correction (dB/m)	Result (dBuV/m)	Limit (dBuV/m)	Margin (dB)	Remark	Ant.Pol. (H/V)
2330.000	53.46	-4.22	49.24	74.00	-24.76	peak	V
N/A							
1735.000	59.03	-6.28	52.75	74.00	-21.25	peak	H
N/A							

Remark:

1. Measuring frequencies from 1 GHz to the 10th harmonic of highest fundamental frequency.
2. Radiated emissions measured in frequency above 1000MHz were made with an instrument using peak/average detector mode.
3. Average test would be performed if the peak result were greater than the average limit.
4. Data of measurement within this frequency range shown “ --- ” in the table above means the reading of emissions are attenuated more than 20dB below the permissible limits or the field strength is too small to be measured.
5. Measurements above show only up to 6 maximum emissions noted, or would be lesser, with “ N/A ” remark, if no specific emissions from the EUT are recorded (ie: margin>20dB from the applicable limit) and considered that's already beyond the background noise floor.
6. Margin (dB) = Remark result (dBuV/m) – Average limit (dBuV/m).



Operation Mode: Tx / IEEE 802.11a mode / 5180 ~ 5240MHz /CH High

Test Date: December 30, 2014

Temperature: 27°C

Tested by: Andy Shi

Humidity: 53% RH

Polarity: Ver. / Hor.

Frequency (MHz)	Reading (dBuV)	Correction (dB/m)	Result (dBuV/m)	Limit (dBuV/m)	Margin (dB)	Remark	Ant.Pol. (H/V)
2330.000	51.93	-4.22	47.71	74.00	-26.29	peak	V
N/A							
4171.000	50.74	1.88	52.62	74.00	-21.38	peak	H
N/A							

Remark:

1. Measuring frequencies from 1 GHz to the 10th harmonic of highest fundamental frequency.
2. Radiated emissions measured in frequency above 1000MHz were made with an instrument using peak/average detector mode.
3. Average test would be performed if the peak result were greater than the average limit.
4. Data of measurement within this frequency range shown “ --- ” in the table above means the reading of emissions are attenuated more than 20dB below the permissible limits or the field strength is too small to be measured.
5. Measurements above show only up to 6 maximum emissions noted, or would be lesser, with “ N/A ” remark, if no specific emissions from the EUT are recorded (ie: margin>20dB from the applicable limit) and considered that's already beyond the background noise floor.
6. Margin (dB) = Remark result (dBuV/m) – Average limit (dBuV/m).



Operation Mode: Tx / IEEE 802.11n HT 20 mode / 5180 ~ 5240MHz / CH Low
Temperature: 27°C
Humidity: 53% RH

Test Date: December 31, 2014
Tested by: Andy Shi
Polarity: Ver. / Hor.

Frequency (MHz)	Reading (dBuV)	Correction (dB/m)	Result (dBuV/m)	Limit (dBuV/m)	Margin (dB)	Remark	Ant.Pol. (H/V)
3702.000	53.85	3.84	57.69	74.00	-16.31	peak	V
N/A							
3660.000	53.39	3.67	57.06	74.00	-16.94	peak	H
N/A							

Remark:

1. Measuring frequencies from 1 GHz to the 10th harmonic of highest fundamental frequency.
2. Radiated emissions measured in frequency above 1000MHz were made with an instrument using peak/average detector mode.
3. Average test would be performed if the peak result were greater than the average limit.
4. Data of measurement within this frequency range shown “ --- ” in the table above means the reading of emissions are attenuated more than 20dB below the permissible limits or the field strength is too small to be measured.
5. Measurements above show only up to 6 maximum emissions noted, or would be lesser, with “ N/A ” remark, if no specific emissions from the EUT are recorded (ie: margin>20dB from the applicable limit) and considered that's already beyond the background noise floor.
6. Margin (dB) = Remark result (dBuV/m) – Average limit (dBuV/m).



Operation Mode: Tx / IEEE 802.11n HT 20 mode / 5180 ~ 5240MHz / CH Mid
Temperature: 27°C
Humidity: 53% RH

Test Date: December 31, 2014
Tested by: Andy Shi
Polarity: Ver. / Hor.

Frequency (MHz)	Reading (dBuV)	Correction (dB/m)	Result (dBuV/m)	Limit (dBuV/m)	Margin (dB)	Remark	Ant.Pol. (H/V)
4108.000	51.44	5.55	56.99	74.00	-17.01	peak	V
N/A							
4402.000	52.13	6.82	58.95	74.00	-15.05	peak	H
N/A							

Remark:

1. Measuring frequencies from 1 GHz to the 10th harmonic of highest fundamental frequency.
2. Radiated emissions measured in frequency above 1000MHz were made with an instrument using peak/average detector mode.
3. Average test would be performed if the peak result were greater than the average limit.
4. Data of measurement within this frequency range shown “ --- ” in the table above means the reading of emissions are attenuated more than 20dB below the permissible limits or the field strength is too small to be measured.
5. Measurements above show only up to 6 maximum emissions noted, or would be lesser, with “ N/A ” remark, if no specific emissions from the EUT are recorded (ie: margin>20dB from the applicable limit) and considered that's already beyond the background noise floor.
6. Margin (dB) = Remark result (dBuV/m) – Average limit (dBuV/m).



Operation Mode: Tx / IEEE 802.11n HT 20 mode / 5180 ~ 5240MHz / CH High

Test Date: December 31, 2014

Temperature: 27°C

Tested by: Andy Shi

Humidity: 53% RH

Polarity: Ver. / Hor.

Frequency (MHz)	Reading (dBuV)	Correction (dB/m)	Result (dBuV/m)	Limit (dBuV/m)	Margin (dB)	Remark	Ant.Pol. (H/V)
3772.000	52.42	4.13	56.55	74.00	-17.45	peak	V
N/A							
4150.000	51.76	5.73	57.49	74.00	-16.51	peak	H
N/A							

Remark:

1. Measuring frequencies from 1 GHz to the 10th harmonic of highest fundamental frequency.
2. Radiated emissions measured in frequency above 1000MHz were made with an instrument using peak/average detector mode.
3. Average test would be performed if the peak result were greater than the average limit.
4. Data of measurement within this frequency range shown “ --- ” in the table above means the reading of emissions are attenuated more than 20dB below the permissible limits or the field strength is too small to be measured.
5. Measurements above show only up to 6 maximum emissions noted, or would be lesser, with “ N/A ” remark, if no specific emissions from the EUT are recorded (ie: margin>20dB from the applicable limit) and considered that's already beyond the background noise floor.
6. Margin (dB) = Remark result (dBuV/m) – Average limit (dBuV/m).



Operation Mode: Tx / IEEE 802.11n HT 40 mode / 5190 ~ 5230MHz / CH Low

Test Date: December 31, 2014

Temperature: 27°C

Tested by: Andy Shi

Humidity: 53% RH

Polarity: Ver. / Hor.

Frequency (MHz)	Reading (dBuV)	Correction (dB/m)	Result (dBuV/m)	Limit (dBuV/m)	Margin (dB)	Remark	Ant.Pol. (H/V)
3737.000	54.35	3.99	58.34	74.00	-15.66	peak	V
N/A							
3688.000	53.23	3.78	57.01	74.00	-16.99	peak	H
N/A							

Remark:

1. Measuring frequencies from 1 GHz to the 10th harmonic of highest fundamental frequency.
2. Radiated emissions measured in frequency above 1000MHz were made with an instrument using peak/average detector mode.
3. Average test would be performed if the peak result were greater than the average limit.
4. Data of measurement within this frequency range shown “ --- ” in the table above means the reading of emissions are attenuated more than 20dB below the permissible limits or the field strength is too small to be measured.
5. Measurements above show only up to 6 maximum emissions noted, or would be lesser, with “ N/A ” remark, if no specific emissions from the EUT are recorded (ie: margin>20dB from the applicable limit) and considered that's already beyond the background noise floor.
6. Margin (dB) = Remark result (dBuV/m) – Average limit (dBuV/m).



Operation Mode: Tx / IEEE 802.11n HT 40 mode / 5190 ~ 5230MHz / CH High

Test Date: December 31, 2014

Temperature: 27°C

Tested by: Andy Shi

Humidity: 53% RH

Polarity: Ver. / Hor.

Frequency (MHz)	Reading (dBuV)	Correction (dB/m)	Result (dBuV/m)	Limit (dBuV/m)	Margin (dB)	Remark	Ant.Pol. (H/V)
3716.000	53.42	3.90	57.32	74.00	-16.68	peak	V
N/A							
4262.000	50.71	6.22	56.93	74.00	-17.07	peak	H
N/A							

Remark:

1. Measuring frequencies from 1 GHz to the 10th harmonic of highest fundamental frequency.
2. Radiated emissions measured in frequency above 1000MHz were made with an instrument using peak/average detector mode.
3. Average test would be performed if the peak result were greater than the average limit.
4. Data of measurement within this frequency range shown “ --- ” in the table above means the reading of emissions are attenuated more than 20dB below the permissible limits or the field strength is too small to be measured.
5. Measurements above show only up to 6 maximum emissions noted, or would be lesser, with “ N/A ” remark, if no specific emissions from the EUT are recorded (ie: margin>20dB from the applicable limit) and considered that's already beyond the background noise floor.
6. Margin (dB) = Remark result (dBuV/m) – Average limit (dBuV/m).



Operation Mode: Tx / IEEE 802.11ac80 mode / 5210MHz

Test Date: December 31, 2014

Temperature: 27°C

Tested by: Andy Shi

Humidity: 53% RH

Polarity: Ver. / Hor.

Frequency (MHz)	Reading (dBuV)	Correction (dB/m)	Result (dBuV/m)	Limit (dBuV/m)	Margin (dB)	Remark	Ant.Pol. (H/V)
3737.000	53.13	3.99	57.12	74.00	-16.88	peak	V
N/A							
2540.000	51.11	-0.16	50.95	74.00	-23.05	peak	H
N/A							

Remark:

1. Measuring frequencies from 1 GHz to the 10th harmonic of highest fundamental frequency.
2. Radiated emissions measured in frequency above 1000MHz were made with an instrument using peak/average detector mode.
3. Average test would be performed if the peak result were greater than the average limit.
4. Data of measurement within this frequency range shown “ --- ” in the table above means the reading of emissions are attenuated more than 20dB below the permissible limits or the field strength is too small to be measured.
5. Measurements above show only up to 6 maximum emissions noted, or would be lesser, with “ N/A ” remark, if no specific emissions from the EUT are recorded (ie: margin>20dB from the applicable limit) and considered that's already beyond the background noise floor.
6. Margin (dB) = Remark result (dBuV/m) – Average limit (dBuV/m).



Operation Mode: Tx / IEEE 802.11a mode / 5745 ~ 5825MHz / CH Low **Test Date:** December 30, 2014
Temperature: 27°C **Tested by:** Andy Shi
Humidity: 53% RH **Polarity:** Ver. / Hor.

Frequency (MHz)	Reading (dBuV)	Correction (dB/m)	Result (dBuV/m)	Limit (dBuV/m)	Margin (dB)	Remark	Ant.Pol. (H/V)
2330.000	53.59	-4.22	49.37	74.00	-24.63	peak	V
N/A							
1336.000	53.72	-8.25	45.47	74.00	-28.53	peak	H
N/A							

Remark:

1. Measuring frequencies from 1 GHz to the 10th harmonic of highest fundamental frequency.
2. Radiated emissions measured in frequency above 1000MHz were made with an instrument using peak/average detector mode.
3. Average test would be performed if the peak result were greater than the average limit.
4. Data of measurement within this frequency range shown “ --- ” in the table above means the reading of emissions are attenuated more than 20dB below the permissible limits or the field strength is too small to be measured.
5. Measurements above show only up to 6 maximum emissions noted, or would be lesser, with “ N/A ” remark, if no specific emissions from the EUT are recorded (ie: margin>20dB from the applicable limit) and considered that's already beyond the background noise floor.
6. Margin (dB) = Remark result (dBuV/m) – Average limit (dBuV/m).



Operation Mode: Tx / IEEE 802.11a mode / 5745 ~ 5825MHz /CH Mid **Test Date:** December 30, 2014
Temperature: 27°C **Tested by:** Andy Shi
Humidity: 53% RH **Polarity:** Ver. / Hor.

Frequency (MHz)	Reading (dBuV)	Correction (dB/m)	Result (dBuV/m)	Limit (dBuV/m)	Margin (dB)	Remark	Ant.Pol. (H/V)
2330.000	53.60	-4.22	49.38	74.00	-24.62	peak	V
N/A							
2183.000	49.54	-4.52	45.02	74.00	-28.98	peak	H
N/A							

Remark:

1. Measuring frequencies from 1 GHz to the 10th harmonic of highest fundamental frequency.
2. Radiated emissions measured in frequency above 1000MHz were made with an instrument using peak/average detector mode.
3. Average test would be performed if the peak result were greater than the average limit.
4. Data of measurement within this frequency range shown “ --- ” in the table above means the reading of emissions are attenuated more than 20dB below the permissible limits or the field strength is too small to be measured.
5. Measurements above show only up to 6 maximum emissions noted, or would be lesser, with “ N/A ” remark, if no specific emissions from the EUT are recorded (ie: margin>20dB from the applicable limit) and considered that's already beyond the background noise floor.
6. Margin (dB) = Remark result (dBuV/m) – Average limit (dBuV/m).



Operation Mode: Tx / IEEE 802.11a mode / 5745 ~ 5825MHz /CH High

Test Date: December 30, 2014

Temperature: 27°C

Tested by: Andy Shi

Humidity: 53% RH

Polarity: Ver. / Hor.

Frequency (MHz)	Reading (dBuV)	Correction (dB/m)	Result (dBuV/m)	Limit (dBuV/m)	Margin (dB)	Remark	Ant.Pol. (H/V)
1924.000	57.79	-5.28	52.51	74.00	-21.49	peak	V
N/A							
1329.000	53.65	-8.28	45.37	74.00	-28.63	peak	H
N/A							

Remark:

1. Measuring frequencies from 1 GHz to the 10th harmonic of highest fundamental frequency.
2. Radiated emissions measured in frequency above 1000MHz were made with an instrument using peak/average detector mode.
3. Average test would be performed if the peak result were greater than the average limit.
4. Data of measurement within this frequency range shown “ --- ” in the table above means the reading of emissions are attenuated more than 20dB below the permissible limits or the field strength is too small to be measured.
5. Measurements above show only up to 6 maximum emissions noted, or would be lesser, with “ N/A ” remark, if no specific emissions from the EUT are recorded (ie: margin>20dB from the applicable limit) and considered that's already beyond the background noise floor.
6. Margin (dB) = Remark result (dBuV/m) – Average limit (dBuV/m).



Operation Mode: Tx / IEEE 802.11n HT 20 mode / 5745 ~ 5825MHz / CH Low

Test Date: December 31, 2014

Temperature: 27°C

Tested by: Andy Shi

Humidity: 53% RH

Polarity: Ver. / Hor.

Frequency (MHz)	Reading (dBuV)	Correction (dB/m)	Result (dBuV/m)	Limit (dBuV/m)	Margin (dB)	Remark	Ant.Pol. (H/V)
3646.000	52.97	3.61	56.58	74.00	-17.42	peak	V
N/A							
4367.000	51.82	6.67	58.49	74.00	-15.51	peak	H
N/A							

Remark:

1. Measuring frequencies from 1 GHz to the 10th harmonic of highest fundamental frequency.
2. Radiated emissions measured in frequency above 1000MHz were made with an instrument using peak/average detector mode.
3. Average test would be performed if the peak result were greater than the average limit.
4. Data of measurement within this frequency range shown “ --- ” in the table above means the reading of emissions are attenuated more than 20dB below the permissible limits or the field strength is too small to be measured.
5. Measurements above show only up to 6 maximum emissions noted, or would be lesser, with “ N/A ” remark, if no specific emissions from the EUT are recorded (ie: margin>20dB from the applicable limit) and considered that's already beyond the background noise floor.
6. Margin (dB) = Remark result (dBuV/m) – Average limit (dBuV/m).



Operation Mode: Tx / IEEE 802.11n HT 20 mode / 5745 ~ 5825MHz / CH Mid

Test Date: December 31, 2014

Temperature: 27°C

Tested by: Andy Shi

Humidity: 53% RH

Polarity: Ver. / Hor.

Frequency (MHz)	Reading (dBuV)	Correction (dB/m)	Result (dBuV/m)	Limit (dBuV/m)	Margin (dB)	Remark	Ant.Pol. (H/V)
4535.000	51.79	7.34	59.13	74.00	-14.87	peak	V
N/A							
4115.000	51.63	5.58	57.21	74.00	-16.79	peak	H
N/A							

Remark:

1. Measuring frequencies from 1 GHz to the 10th harmonic of highest fundamental frequency.
2. Radiated emissions measured in frequency above 1000MHz were made with an instrument using peak/average detector mode.
3. Average test would be performed if the peak result were greater than the average limit.
4. Data of measurement within this frequency range shown “ --- ” in the table above means the reading of emissions are attenuated more than 20dB below the permissible limits or the field strength is too small to be measured.
5. Measurements above show only up to 6 maximum emissions noted, or would be lesser, with “ N/A ” remark, if no specific emissions from the EUT are recorded (ie: margin>20dB from the applicable limit) and considered that's already beyond the background noise floor.
6. Margin (dB) = Remark result (dBuV/m) – Average limit (dBuV/m).



Operation Mode: Tx / IEEE 802.11n HT 20 mode / 5745 ~ 5825MHz / CH High

Test Date: December 31, 2014

Temperature: 27°C

Tested by: Andy Shi

Humidity: 53% RH

Polarity: Ver. / Hor.

Frequency (MHz)	Reading (dBuV)	Correction (dB/m)	Result (dBuV/m)	Limit (dBuV/m)	Margin (dB)	Remark	Ant.Pol. (H/V)
4885.000	52.11	8.27	60.38	74.00	-13.62	peak	V
N/A							
3695.000	53.17	3.81	56.98	74.00	-17.02	peak	H
N/A							

Remark:

1. Measuring frequencies from 1 GHz to the 10th harmonic of highest fundamental frequency.
2. Radiated emissions measured in frequency above 1000MHz were made with an instrument using peak/average detector mode.
3. Average test would be performed if the peak result were greater than the average limit.
4. Data of measurement within this frequency range shown “ --- ” in the table above means the reading of emissions are attenuated more than 20dB below the permissible limits or the field strength is too small to be measured.
5. Measurements above show only up to 6 maximum emissions noted, or would be lesser, with “ N/A ” remark, if no specific emissions from the EUT are recorded (ie: margin>20dB from the applicable limit) and considered that's already beyond the background noise floor.
6. Margin (dB) = Remark result (dBuV/m) – Average limit (dBuV/m).



Operation Mode: Tx / IEEE 802.11n HT 40 mode / 5755 ~ 5795MHz / CH Low

Test Date: December 31, 2014

Temperature: 27°C

Tested by: Andy Shi

Humidity: 53% RH

Polarity: Ver. / Hor.

Frequency (MHz)	Reading (dBuV)	Correction (dB/m)	Result (dBuV/m)	Limit (dBuV/m)	Margin (dB)	Remark	Ant.Pol. (H/V)
3737.000	54.35	3.99	58.34	74.00	-15.66	peak	V
N/A							
3688.000	53.23	3.78	57.01	74.00	-16.99	peak	H
N/A							

Remark:

1. Measuring frequencies from 1 GHz to the 10th harmonic of highest fundamental frequency.
2. Radiated emissions measured in frequency above 1000MHz were made with an instrument using peak/average detector mode.
3. Average test would be performed if the peak result were greater than the average limit.
4. Data of measurement within this frequency range shown “ --- ” in the table above means the reading of emissions are attenuated more than 20dB below the permissible limits or the field strength is too small to be measured.
5. Measurements above show only up to 6 maximum emissions noted, or would be lesser, with “ N/A ” remark, if no specific emissions from the EUT are recorded (ie: margin>20dB from the applicable limit) and considered that's already beyond the background noise floor.
6. Margin (dB) = Remark result (dBuV/m) – Average limit (dBuV/m).



Operation Mode: Tx / IEEE 802.11n HT 40 mode / 5755 ~ 5795MHz / CH High

Test Date: December 31, 2014

Temperature: 27°C

Tested by: Andy Shi

Humidity: 53% RH

Polarity: Ver. / Hor.

Frequency (MHz)	Reading (dBuV)	Correction (dB/m)	Result (dBuV/m)	Limit (dBuV/m)	Margin (dB)	Remark	Ant.Pol. (H/V)
3716.000	53.42	3.90	57.32	74.00	-16.68	peak	V
N/A							
4262.000	50.71	6.22	56.93	74.00	-17.07	peak	H
N/A							

Remark:

1. Measuring frequencies from 1 GHz to the 10th harmonic of highest fundamental frequency.
2. Radiated emissions measured in frequency above 1000MHz were made with an instrument using peak/average detector mode.
3. Average test would be performed if the peak result were greater than the average limit.
4. Data of measurement within this frequency range shown “ --- ” in the table above means the reading of emissions are attenuated more than 20dB below the permissible limits or the field strength is too small to be measured.
5. Measurements above show only up to 6 maximum emissions noted, or would be lesser, with “ N/A ” remark, if no specific emissions from the EUT are recorded (ie: margin>20dB from the applicable limit) and considered that's already beyond the background noise floor.
6. Margin (dB) = Remark result (dBuV/m) – Average limit (dBuV/m).



Operation Mode: Tx / IEEE 802.11ac80 mode / 5755MHz

Test Date: December 31, 2014

Temperature: 27°C

Tested by: Andy Shi

Humidity: 53% RH

Polarity: Ver. / Hor.

Frequency (MHz)	Reading (dBuV)	Correction (dB/m)	Result (dBuV/m)	Limit (dBuV/m)	Margin (dB)	Remark	Ant.Pol. (H/V)
3772.000	52.89	4.13	57.02	74.00	-16.98	peak	V
N/A							
4654.000	52.31	7.66	59.97	74.00	-14.03	peak	H
N/A							

Remark:

1. Measuring frequencies from 1 GHz to the 10th harmonic of highest fundamental frequency.
2. Radiated emissions measured in frequency above 1000MHz were made with an instrument using peak/average detector mode.
3. Average test would be performed if the peak result were greater than the average limit.
4. Data of measurement within this frequency range shown “ --- ” in the table above means the reading of emissions are attenuated more than 20dB below the permissible limits or the field strength is too small to be measured.
5. Measurements above show only up to 6 maximum emissions noted, or would be lesser, with “ N/A ” remark, if no specific emissions from the EUT are recorded (ie: margin>20dB from the applicable limit) and considered that's already beyond the background noise floor.
6. Margin (dB) = Remark result (dBuV/m) – Average limit (dBuV/m).

**For Dipole Antenna****Below 1 GHz****Operation Mode:** Normal Link**Test Date:** December 27, 2014**Temperature:** 27°C**Tested by:** Andy Shi**Humidity:** 53% RH**Polarity:** Ver. / Hor.

Frequency (MHz)	Reading (dBuV)	Correction Factor (dB/m)	Result (dBuV/m)	Limit (dBuV/m)	Margin (dB)	Remark	Ant.Pol. (H/V)
57.1600	55.75	-23.64	32.11	40.00	-7.89	peak	V
205.5700	41.09	-17.94	23.15	43.50	-20.35	peak	V
335.5500	50.16	-15.54	34.62	46.00	-11.38	peak	V
498.5100	45.77	-11.85	33.92	46.00	-12.08	peak	V
665.3500	46.17	-9.15	37.02	46.00	-8.98	peak	V
914.6400	36.99	-5.96	31.03	46.00	-14.97	peak	V
57.1600	55.24	-23.64	31.60	40.00	-8.40	peak	H
239.5200	48.93	-18.62	30.31	46.00	-15.69	peak	H
365.6200	52.86	-14.82	38.04	46.00	-7.96	peak	H
566.4100	37.68	-10.84	26.84	46.00	-19.16	peak	H
665.3500	46.25	-9.15	37.10	46.00	-8.90	peak	H
832.1900	40.82	-6.99	33.83	46.00	-12.17	peak	H

Remark:

1. No emission found between lowest internal used/generated frequency to 30MHz (9kHz~30MHz)
2. Radiated emissions measured in frequency range from 30 MHz to 1000MHz were made with an instrument using peak/quasi-peak detector mode.
3. Quasi-peak test would be performed if the peak result were greater than the quasi-peak limit.
4. Data of measurement within this frequency range shown " --- " in the table above means the reading of emissions are attenuated more than 20dB below the permissible limits or the field strength is too small to be measured.
5. Measurements above show only up to 6 maximum emissions noted, or would be lesser, with " N/A " remark, if no specific emissions from the EUT are recorded (ie: margin>20dB from the applicable limit) and considered that's already beyond the background noise floor.
6. $Margin (dB) = Remark\ result (dBuV/m) - Quasi-peak\ limit (dBuV/m)$.



Above 1 GHz

Operation Mode: Tx / IEEE 802.11a mode / 5180 ~ 5240MHz / CH Low **Test Date:** December 28, 2014

Temperature: 27°C **Tested by:** Andy Shi

Humidity: 53% RH **Polarity:** Ver. / Hor.

Frequency (MHz)	Reading (dBuV)	Correction (dB/m)	Result (dBuV/m)	Limit (dBuV/m)	Margin (dB)	Remark	Ant.Pol. (H/V)
3086.000	52.11	-1.90	50.21	74.00	-23.79	peak	V
N/A							
3135.000	51.67	-1.79	49.88	74.00	-24.12	peak	H
N/A							

Remark:

1. Measuring frequencies from 1 GHz to the 10th harmonic of highest fundamental frequency.
2. Radiated emissions measured in frequency above 1000MHz were made with an instrument using peak/average detector mode.
3. Average test would be performed if the peak result were greater than the average limit.
4. Data of measurement within this frequency range shown “ --- ” in the table above means the reading of emissions are attenuated more than 20dB below the permissible limits or the field strength is too small to be measured.
5. Measurements above show only up to 6 maximum emissions noted, or would be lesser, with “ N/A ” remark, if no specific emissions from the EUT are recorded (ie: margin>20dB from the applicable limit) and considered that's already beyond the background noise floor.
6. $Margin (dB) = Remark\ result (dBuV/m) - Average\ limit (dBuV/m)$.



Operation Mode: Tx / IEEE 802.11a mode / 5180 ~ 5240MHz /CH Mid **Test Date:** December 28, 2014
Temperature: 27°C **Tested by:** Andy Shi
Humidity: 53% RH **Polarity:** Ver. / Hor.

Frequency (MHz)	Reading (dBuV)	Correction (dB/m)	Result (dBuV/m)	Limit (dBuV/m)	Margin (dB)	Remark	Ant.Pol. (H/V)
2330.000	54.15	-4.22	49.93	74.00	-24.07	peak	V
N/A							
3233.000	52.40	-1.55	50.85	74.00	-23.15	peak	H
N/A							

Remark:

1. Measuring frequencies from 1 GHz to the 10th harmonic of highest fundamental frequency.
2. Radiated emissions measured in frequency above 1000MHz were made with an instrument using peak/average detector mode.
3. Average test would be performed if the peak result were greater than the average limit.
4. Data of measurement within this frequency range shown “ --- ” in the table above means the reading of emissions are attenuated more than 20dB below the permissible limits or the field strength is too small to be measured.
5. Measurements above show only up to 6 maximum emissions noted, or would be lesser, with “ N/A ” remark, if no specific emissions from the EUT are recorded (ie: margin>20dB from the applicable limit) and considered that's already beyond the background noise floor.
6. Margin (dB) = Remark result (dBuV/m) – Average limit (dBuV/m).



Operation Mode: Tx / IEEE 802.11a mode / 5180 ~ 5240MHz /CH High

Test Date: December 28, 2014

Temperature: 27°C

Tested by: Andy Shi

Humidity: 53% RH

Polarity: Ver. / Hor.

Frequency (MHz)	Reading (dBuV)	Correction (dB/m)	Result (dBuV/m)	Limit (dBuV/m)	Margin (dB)	Remark	Ant.Pol. (H/V)
2330.000	52.36	-4.22	48.14	74.00	-25.86	peak	V
N/A							
2491.000	50.16	-3.20	46.96	74.00	-27.04	peak	H
N/A							

Remark:

1. Measuring frequencies from 1 GHz to the 10th harmonic of highest fundamental frequency.
2. Radiated emissions measured in frequency above 1000MHz were made with an instrument using peak/average detector mode.
3. Average test would be performed if the peak result were greater than the average limit.
4. Data of measurement within this frequency range shown “ --- ” in the table above means the reading of emissions are attenuated more than 20dB below the permissible limits or the field strength is too small to be measured.
5. Measurements above show only up to 6 maximum emissions noted, or would be lesser, with “ N/A ” remark, if no specific emissions from the EUT are recorded (ie: margin>20dB from the applicable limit) and considered that's already beyond the background noise floor.
6. Margin (dB) = Remark result (dBuV/m) – Average limit (dBuV/m).



Operation Mode: Tx / IEEE 802.11n HT 20 mode / 5180 ~ 5240MHz / CH Low

Test Date: December 28, 2014

Temperature: 27°C

Tested by: Andy Shi

Humidity: 53% RH

Polarity: Ver. / Hor.

Frequency (MHz)	Reading (dBuV)	Correction (dB/m)	Result (dBuV/m)	Limit (dBuV/m)	Margin (dB)	Remark	Ant.Pol. (H/V)
1959.000	50.87	-5.10	45.77	74.00	-28.23	peak	V
N/A							
2743.000	50.02	-2.63	47.39	74.00	-26.61	peak	H
N/A							

Remark:

1. Measuring frequencies from 1 GHz to the 10th harmonic of highest fundamental frequency.
2. Radiated emissions measured in frequency above 1000MHz were made with an instrument using peak/average detector mode.
3. Average test would be performed if the peak result were greater than the average limit.
4. Data of measurement within this frequency range shown “ --- ” in the table above means the reading of emissions are attenuated more than 20dB below the permissible limits or the field strength is too small to be measured.
5. Measurements above show only up to 6 maximum emissions noted, or would be lesser, with “ N/A ” remark, if no specific emissions from the EUT are recorded (ie: margin>20dB from the applicable limit) and considered that's already beyond the background noise floor.
6. Margin (dB) = Remark result (dBuV/m) – Average limit (dBuV/m).



Operation Mode: Tx / IEEE 802.11n HT 20 mode / 5180 ~ 5240MHz / CH Mid
Temperature: 27°C
Humidity: 53% RH

Test Date: December 28, 2014
Tested by: Andy Shi
Polarity: Ver. / Hor.

Frequency (MHz)	Reading (dBuV)	Correction (dB/m)	Result (dBuV/m)	Limit (dBuV/m)	Margin (dB)	Remark	Ant.Pol. (H/V)
2484.000	51.58	-3.27	48.31	74.00	-25.69	peak	V
N/A							
2624.000	49.97	-2.87	47.10	74.00	-26.90	peak	H
N/A							

Remark:

1. Measuring frequencies from 1 GHz to the 10th harmonic of highest fundamental frequency.
2. Radiated emissions measured in frequency above 1000MHz were made with an instrument using peak/average detector mode.
3. Average test would be performed if the peak result were greater than the average limit.
4. Data of measurement within this frequency range shown “ --- ” in the table above means the reading of emissions are attenuated more than 20dB below the permissible limits or the field strength is too small to be measured.
5. Measurements above show only up to 6 maximum emissions noted, or would be lesser, with “ N/A ” remark, if no specific emissions from the EUT are recorded (ie: margin>20dB from the applicable limit) and considered that's already beyond the background noise floor.
6. Margin (dB) = Remark result (dBuV/m) – Average limit (dBuV/m).



Operation Mode: Tx / IEEE 802.11n HT 20 mode / 5180 ~ 5240MHz / CH High

Test Date: December 28, 2014

Temperature: 27°C

Tested by: Andy Shi

Humidity: 53% RH

Polarity: Ver. / Hor.

Frequency (MHz)	Reading (dBuV)	Correction (dB/m)	Result (dBuV/m)	Limit (dBuV/m)	Margin (dB)	Remark	Ant.Pol. (H/V)
2330.000	52.15	-4.22	47.93	74.00	-26.07	peak	V
N/A							
2554.000	51.14	-3.01	48.13	74.00	-25.87	peak	H
N/A							

Remark:

1. Measuring frequencies from 1 GHz to the 10th harmonic of highest fundamental frequency.
2. Radiated emissions measured in frequency above 1000MHz were made with an instrument using peak/average detector mode.
3. Average test would be performed if the peak result were greater than the average limit.
4. Data of measurement within this frequency range shown “ --- ” in the table above means the reading of emissions are attenuated more than 20dB below the permissible limits or the field strength is too small to be measured.
5. Measurements above show only up to 6 maximum emissions noted, or would be lesser, with “ N/A ” remark, if no specific emissions from the EUT are recorded (ie: margin>20dB from the applicable limit) and considered that's already beyond the background noise floor.
6. Margin (dB) = Remark result (dBuV/m) – Average limit (dBuV/m).



Operation Mode: Tx / IEEE 802.11n HT 40 mode / 5190 ~ 5230MHz / CH Low

Test Date: December 28, 2014

Temperature: 27°C

Tested by: Andy Shi

Humidity: 53% RH

Polarity: Ver. / Hor.

Frequency (MHz)	Reading (dBuV)	Correction (dB/m)	Result (dBuV/m)	Limit (dBuV/m)	Margin (dB)	Remark	Ant.Pol. (H/V)
1952.000	51.40	-5.13	46.27	74.00	-27.73	peak	V
N/A							
2330.000	50.64	-4.22	46.42	74.00	-27.58	peak	H
N/A							

Remark:

1. Measuring frequencies from 1 GHz to the 10th harmonic of highest fundamental frequency.
2. Radiated emissions measured in frequency above 1000MHz were made with an instrument using peak/average detector mode.
3. Average test would be performed if the peak result were greater than the average limit.
4. Data of measurement within this frequency range shown “ --- ” in the table above means the reading of emissions are attenuated more than 20dB below the permissible limits or the field strength is too small to be measured.
5. Measurements above show only up to 6 maximum emissions noted, or would be lesser, with “ N/A ” remark, if no specific emissions from the EUT are recorded (ie: margin>20dB from the applicable limit) and considered that's already beyond the background noise floor.
6. Margin (dB) = Remark result (dBuV/m) – Average limit (dBuV/m).



Operation Mode: Tx / IEEE 802.11n HT 40 mode / 5190 ~ 5230MHz / CH High

Test Date: December 28, 2014

Temperature: 27°C

Tested by: Andy Shi

Humidity: 53% RH

Polarity: Ver. / Hor.

Frequency (MHz)	Reading (dBuV)	Correction (dB/m)	Result (dBuV/m)	Limit (dBuV/m)	Margin (dB)	Remark	Ant.Pol. (H/V)
2330.000	50.88	-4.22	46.66	74.00	-27.34	peak	V
N/A							
1952.000	50.93	-5.13	45.80	74.00	-28.20	peak	H
N/A							

Remark:

1. Measuring frequencies from 1 GHz to the 10th harmonic of highest fundamental frequency.
2. Radiated emissions measured in frequency above 1000MHz were made with an instrument using peak/average detector mode.
3. Average test would be performed if the peak result were greater than the average limit.
4. Data of measurement within this frequency range shown " --- " in the table above means the reading of emissions are attenuated more than 20dB below the permissible limits or the field strength is too small to be measured.
5. Measurements above show only up to 6 maximum emissions noted, or would be lesser, with " N/A " remark, if no specific emissions from the EUT are recorded (ie: margin>20dB from the applicable limit) and considered that's already beyond the background noise floor.
6. Margin (dB) = Remark result (dBuV/m) – Average limit (dBuV/m).



Operation Mode: Tx / IEEE 802.11ac80 mode / 5210MHz

Test Date: December 28, 2014

Temperature: 27°C

Tested by: Andy Shi

Humidity: 53% RH

Polarity: Ver. / Hor.

Frequency (MHz)	Reading (dBuV)	Correction (dB/m)	Result (dBuV/m)	Limit (dBuV/m)	Margin (dB)	Remark	Ant.Pol. (H/V)
2659.000	50.06	-2.80	47.26	74.00	-26.74	peak	V
N/A							
2638.000	50.13	-2.84	47.29	74.00	-26.71	peak	H
N/A							

Remark:

1. Measuring frequencies from 1 GHz to the 10th harmonic of highest fundamental frequency.
2. Radiated emissions measured in frequency above 1000MHz were made with an instrument using peak/average detector mode.
3. Average test would be performed if the peak result were greater than the average limit.
4. Data of measurement within this frequency range shown “ --- ” in the table above means the reading of emissions are attenuated more than 20dB below the permissible limits or the field strength is too small to be measured.
5. Measurements above show only up to 6 maximum emissions noted, or would be lesser, with “ N/A ” remark, if no specific emissions from the EUT are recorded (ie: margin>20dB from the applicable limit) and considered that's already beyond the background noise floor.
6. Margin (dB) = Remark result (dBuV/m) – Average limit (dBuV/m).



Operation Mode: Tx / IEEE 802.11a mode / 5745 ~ 5825MHz / CH Low **Test Date:** December 28, 2014
Temperature: 27°C **Tested by:** Andy Shi
Humidity: 53% RH **Polarity:** Ver. / Hor.

Frequency (MHz)	Reading (dBuV)	Correction (dB/m)	Result (dBuV/m)	Limit (dBuV/m)	Margin (dB)	Remark	Ant.Pol. (H/V)
1952.000	52.58	-5.13	47.45	74.00	-26.55	peak	V
N/A							
1945.000	50.80	-5.17	45.63	74.00	-28.37	peak	H
N/A							

Remark:

1. Measuring frequencies from 1 GHz to the 10th harmonic of highest fundamental frequency.
2. Radiated emissions measured in frequency above 1000MHz were made with an instrument using peak/average detector mode.
3. Average test would be performed if the peak result were greater than the average limit.
4. Data of measurement within this frequency range shown “ --- ” in the table above means the reading of emissions are attenuated more than 20dB below the permissible limits or the field strength is too small to be measured.
5. Measurements above show only up to 6 maximum emissions noted, or would be lesser, with “ N/A ” remark, if no specific emissions from the EUT are recorded (ie: margin>20dB from the applicable limit) and considered that's already beyond the background noise floor.
6. Margin (dB) = Remark result (dBuV/m) – Average limit (dBuV/m).



Operation Mode: Tx / IEEE 802.11a mode / 5745 ~ 5825MHz /CH Mid **Test Date:** December 28, 2014
Temperature: 27°C **Tested by:** Andy Shi
Humidity: 53% RH **Polarity:** Ver. / Hor.

Frequency (MHz)	Reading (dBuV)	Correction (dB/m)	Result (dBuV/m)	Limit (dBuV/m)	Margin (dB)	Remark	Ant.Pol. (H/V)
2421.000	51.17	-3.63	47.54	74.00	-26.46	peak	V
N/A							
1952.000	50.36	-5.13	45.23	74.00	-28.77	peak	H
N/A							

Remark:

1. Measuring frequencies from 1 GHz to the 10th harmonic of highest fundamental frequency.
2. Radiated emissions measured in frequency above 1000MHz were made with an instrument using peak/average detector mode.
3. Average test would be performed if the peak result were greater than the average limit.
4. Data of measurement within this frequency range shown “ --- ” in the table above means the reading of emissions are attenuated more than 20dB below the permissible limits or the field strength is too small to be measured.
5. Measurements above show only up to 6 maximum emissions noted, or would be lesser, with “ N/A ” remark, if no specific emissions from the EUT are recorded (ie: margin>20dB from the applicable limit) and considered that's already beyond the background noise floor.
6. Margin (dB) = Remark result (dBuV/m) – Average limit (dBuV/m).



Operation Mode: Tx / IEEE 802.11a mode / 5745 ~ 5825MHz /CH High

Test Date: December 28, 2014

Temperature: 27°C

Tested by: Andy Shi

Humidity: 53% RH

Polarity: Ver. / Hor.

Frequency (MHz)	Reading (dBuV)	Correction (dB/m)	Result (dBuV/m)	Limit (dBuV/m)	Margin (dB)	Remark	Ant.Pol. (H/V)
2330.000	51.70	-4.22	47.48	74.00	-26.52	peak	V
N/A							
2743.000	48.91	-2.63	46.28	74.00	-27.72	peak	H
N/A							

Remark:

1. Measuring frequencies from 1 GHz to the 10th harmonic of highest fundamental frequency.
2. Radiated emissions measured in frequency above 1000MHz were made with an instrument using peak/average detector mode.
3. Average test would be performed if the peak result were greater than the average limit.
4. Data of measurement within this frequency range shown “ --- ” in the table above means the reading of emissions are attenuated more than 20dB below the permissible limits or the field strength is too small to be measured.
5. Measurements above show only up to 6 maximum emissions noted, or would be lesser, with “ N/A ” remark, if no specific emissions from the EUT are recorded (ie: margin>20dB from the applicable limit) and considered that's already beyond the background noise floor.
6. Margin (dB) = Remark result (dBuV/m) – Average limit (dBuV/m).



Operation Mode: Tx / IEEE 802.11n HT 20 mode / 5745 ~ 5825MHz / CH Low

Test Date: December 28, 2014

Temperature: 27°C

Tested by: Andy Shi

Humidity: 53% RH

Polarity: Ver. / Hor.

Frequency (MHz)	Reading (dBuV)	Correction (dB/m)	Result (dBuV/m)	Limit (dBuV/m)	Margin (dB)	Remark	Ant.Pol. (H/V)
2085.000	50.09	-4.97	45.12	74.00	-28.88	peak	V
N/A							
1952.000	51.56	-5.13	46.43	74.00	-27.57	peak	H
N/A							

Remark:

1. Measuring frequencies from 1 GHz to the 10th harmonic of highest fundamental frequency.
2. Radiated emissions measured in frequency above 1000MHz were made with an instrument using peak/average detector mode.
3. Average test would be performed if the peak result were greater than the average limit.
4. Data of measurement within this frequency range shown “ --- ” in the table above means the reading of emissions are attenuated more than 20dB below the permissible limits or the field strength is too small to be measured.
5. Measurements above show only up to 6 maximum emissions noted, or would be lesser, with “ N/A ” remark, if no specific emissions from the EUT are recorded (ie: margin>20dB from the applicable limit) and considered that's already beyond the background noise floor.
6. Margin (dB) = Remark result (dBuV/m) – Average limit (dBuV/m).



Operation Mode: Tx / IEEE 802.11n HT 20 mode / 5745 ~ 5825MHz / CH Mid

Test Date: December 28, 2014

Temperature: 27°C

Tested by: Andy Shi

Humidity: 53% RH

Polarity: Ver. / Hor.

Frequency (MHz)	Reading (dBuV)	Correction (dB/m)	Result (dBuV/m)	Limit (dBuV/m)	Margin (dB)	Remark	Ant.Pol. (H/V)
1952.000	51.30	-5.13	46.17	74.00	-27.83	peak	V
N/A							
2589.000	49.32	-2.94	46.38	74.00	-27.62	peak	H
N/A							

Remark:

1. Measuring frequencies from 1 GHz to the 10th harmonic of highest fundamental frequency.
2. Radiated emissions measured in frequency above 1000MHz were made with an instrument using peak/average detector mode.
3. Average test would be performed if the peak result were greater than the average limit.
4. Data of measurement within this frequency range shown “ --- ” in the table above means the reading of emissions are attenuated more than 20dB below the permissible limits or the field strength is too small to be measured.
5. Measurements above show only up to 6 maximum emissions noted, or would be lesser, with “ N/A ” remark, if no specific emissions from the EUT are recorded (ie: margin>20dB from the applicable limit) and considered that's already beyond the background noise floor.
6. Margin (dB) = Remark result (dBuV/m) – Average limit (dBuV/m).



Operation Mode: Tx / IEEE 802.11n HT 20 mode / 5745 ~ 5825MHz / CH High

Test Date: December 28, 2014

Temperature: 27°C

Tested by: Andy Shi

Humidity: 53% RH

Polarity: Ver. / Hor.

Frequency (MHz)	Reading (dBuV)	Correction (dB/m)	Result (dBuV/m)	Limit (dBuV/m)	Margin (dB)	Remark	Ant.Pol. (H/V)
2330.000	51.20	-4.22	46.98	74.00	-27.02	peak	V
N/A							
2561.000	49.38	-3.00	46.38	74.00	-27.62	peak	H
N/A							

Remark:

1. Measuring frequencies from 1 GHz to the 10th harmonic of highest fundamental frequency.
2. Radiated emissions measured in frequency above 1000MHz were made with an instrument using peak/average detector mode.
3. Average test would be performed if the peak result were greater than the average limit.
4. Data of measurement within this frequency range shown “ --- ” in the table above means the reading of emissions are attenuated more than 20dB below the permissible limits or the field strength is too small to be measured.
5. Measurements above show only up to 6 maximum emissions noted, or would be lesser, with “ N/A ” remark, if no specific emissions from the EUT are recorded (ie: margin>20dB from the applicable limit) and considered that's already beyond the background noise floor.
6. Margin (dB) = Remark result (dBuV/m) – Average limit (dBuV/m).



Operation Mode: Tx / IEEE 802.11n HT 40 mode / 5755 ~ 5795MHz / CH Low

Test Date: December 28, 2014

Temperature: 27°C

Tested by: Andy Shi

Humidity: 53% RH

Polarity: Ver. / Hor.

Frequency (MHz)	Reading (dBuV)	Correction (dB/m)	Result (dBuV/m)	Limit (dBuV/m)	Margin (dB)	Remark	Ant.Pol. (H/V)
2330.000	51.25	-4.22	47.03	74.00	-26.97	peak	V
N/A							
2428.000	49.85	-3.58	46.27	74.00	-27.73	peak	H
N/A							

Remark:

1. Measuring frequencies from 1 GHz to the 10th harmonic of highest fundamental frequency.
2. Radiated emissions measured in frequency above 1000MHz were made with an instrument using peak/average detector mode.
3. Average test would be performed if the peak result were greater than the average limit.
4. Data of measurement within this frequency range shown “ --- ” in the table above means the reading of emissions are attenuated more than 20dB below the permissible limits or the field strength is too small to be measured.
5. Measurements above show only up to 6 maximum emissions noted, or would be lesser, with “ N/A ” remark, if no specific emissions from the EUT are recorded (ie: margin>20dB from the applicable limit) and considered that's already beyond the background noise floor.
6. Margin (dB) = Remark result (dBuV/m) – Average limit (dBuV/m).



Operation Mode: Tx / IEEE 802.11n HT 40 mode / 5755 ~ 5795MHz / CH High

Test Date: December 28, 2014

Temperature: 27°C

Tested by: Andy Shi

Humidity: 53% RH

Polarity: Ver. / Hor.

Frequency (MHz)	Reading (dBuV)	Correction (dB/m)	Result (dBuV/m)	Limit (dBuV/m)	Margin (dB)	Remark	Ant.Pol. (H/V)
2330.000	51.02	-4.22	46.80	74.00	-27.20	peak	V
N/A							
1952.000	51.27	-5.13	46.14	74.00	-27.86	peak	H
N/A							

Remark:

1. Measuring frequencies from 1 GHz to the 10th harmonic of highest fundamental frequency.
2. Radiated emissions measured in frequency above 1000MHz were made with an instrument using peak/average detector mode.
3. Average test would be performed if the peak result were greater than the average limit.
4. Data of measurement within this frequency range shown “ --- ” in the table above means the reading of emissions are attenuated more than 20dB below the permissible limits or the field strength is too small to be measured.
5. Measurements above show only up to 6 maximum emissions noted, or would be lesser, with “ N/A ” remark, if no specific emissions from the EUT are recorded (ie: margin>20dB from the applicable limit) and considered that's already beyond the background noise floor.
6. Margin (dB) = Remark result (dBuV/m) – Average limit (dBuV/m).



Operation Mode: Tx / IEEE 802.11ac80 mode / 5755MHz

Test Date: December 28, 2014

Temperature: 27°C

Tested by: Andy Shi

Humidity: 53% RH

Polarity: Ver. / Hor.

Frequency (MHz)	Reading (dBuV)	Correction (dB/m)	Result (dBuV/m)	Limit (dBuV/m)	Margin (dB)	Remark	Ant.Pol. (H/V)
2330.000	51.98	-4.22	47.76	74.00	-26.24	peak	V
N/A							
2638.000	49.54	-2.84	46.70	74.00	-27.30	peak	H
N/A							

Remark:

1. Measuring frequencies from 1 GHz to the 10th harmonic of highest fundamental frequency.
2. Radiated emissions measured in frequency above 1000MHz were made with an instrument using peak/average detector mode.
3. Average test would be performed if the peak result were greater than the average limit.
4. Data of measurement within this frequency range shown “ --- ” in the table above means the reading of emissions are attenuated more than 20dB below the permissible limits or the field strength is too small to be measured.
5. Measurements above show only up to 6 maximum emissions noted, or would be lesser, with “ N/A ” remark, if no specific emissions from the EUT are recorded (ie: margin>20dB from the applicable limit) and considered that's already beyond the background noise floor.
6. Margin (dB) = Remark result (dBuV/m) – Average limit (dBuV/m).



7.6 POWERLINE CONDUCTED EMISSIONS

LIMIT

According to §15.207(a), except as shown in paragraphs (b) and (c) of this section, for an intentional radiator that is designed to be connected to the public utility (AC) power line, the radio frequency voltage that is conducted back onto the AC power line on any frequency or frequencies within the band 150 kHz to 30 MHz shall not exceed the limits in the following table, as measured using a 50 μ H/50 ohms line impedance stabilization network (LISN). Compliance with the provisions of this paragraph shall be based on the measurement of the radio frequency voltage between each power line and ground at the power terminal. The lower limit applies at the boundary between the frequency ranges.

Frequency Range (MHz)	Limits (dB μ V)	
	Quasi-peak	Average
0.15 to 0.50	66 to 56*	56 to 46*
0.50 to 5	56	46
5 to 30	60	50

* Decreases with the logarithm of the frequency.

TEST CONFIGURATION

See test photographs attached in Appendix 1 for the actual connections between EUT and support equipment.

TEST PROCEDURE

1. The EUT was placed on a table, which is 0.8m above ground plane.
2. Maximum procedure was performed on the six highest emissions to ensure EUT compliance.
3. Repeat above procedures until all frequency measured were complete.

**TEST RESULTS**

The initial step in collecting conducted data is a spectrum analyzer peak scan of the measurement range. Significant peaks are then marked as shown on the following data page, and these signals are then quasi-peaked.

For printed Antenna**Test Data**

Operation Mode: Normal Link **Test Date:** January 5, 2015
Temperature: 24°C **Tested by:** Sehni Hu
Humidity: 50% RH

Freq. (MHz)	QP Reading (dBuV)	AV Reading (dBuV)	Corr. factor (dB/m)	QP Result (dBuV/m)	AV Result (dBuV/m)	QP Limit (dBuV)	AV Limit (dBuV)	QP Margin (dB)	AV Margin (dB)	Note
0.1500	37.49	29.61	9.87	47.36	39.48	65.99	56.00	-18.63	-16.52	L1
0.2123	38.01	30.21	9.87	47.88	40.08	63.11	53.11	-15.23	-13.03	L1
2.9095	16.71	12.95	9.98	26.69	22.93	56.00	46.00	-29.31	-23.07	L1
12.8623	24.72	24.37	10.22	34.94	34.59	60.00	50.00	-25.06	-15.41	L1
14.6266	28.33	24.57	10.26	38.59	34.83	60.00	50.00	-21.41	-15.17	L1
29.2502	34.95	29.67	10.74	45.69	40.41	60.00	50.00	-14.31	-9.59	L1
0.1539	32.97	24.50	9.63	42.60	34.13	65.78	55.79	-23.18	-21.66	L2
0.2136	37.94	30.19	9.64	47.58	39.83	63.06	53.06	-15.48	-13.23	L2
2.9103	17.32	13.83	9.76	27.08	23.59	56.00	46.00	-28.92	-22.41	L2
12.9290	24.42	23.95	10.06	34.48	34.01	60.00	50.00	-25.52	-15.99	L2
14.6262	30.40	26.67	10.11	40.51	36.78	60.00	50.00	-19.49	-13.22	L2
29.2498	36.39	31.12	10.64	47.03	41.76	60.00	50.00	-12.97	-8.24	L2

Remark:

1. Measuring frequencies from 0.15 MHz to 30MHz.
2. The emissions measured in frequency range from 0.15 MHz to 30MHz were made with an instrument using Quasi-peak detector and average detector.
3. The IF bandwidth of SPA between 0.15MHz and 30MHz was 10 kHz; the IF bandwidth of Test Receiver between 0.15MHz and 30MHz was 9 kHz;
4. L1 = Line One (Live Line) / L2 = Line Two (Neutral Line)



Test Plots

Conducted emissions (Line 1)

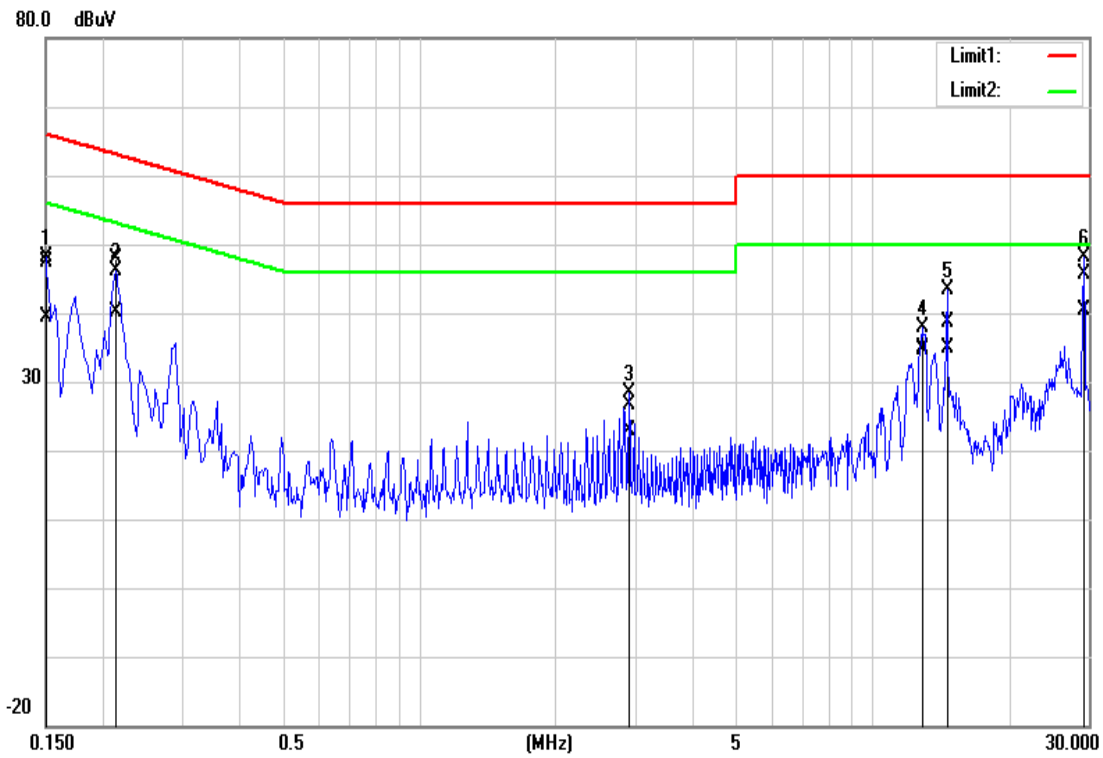

Conducted emissions (Line 2)

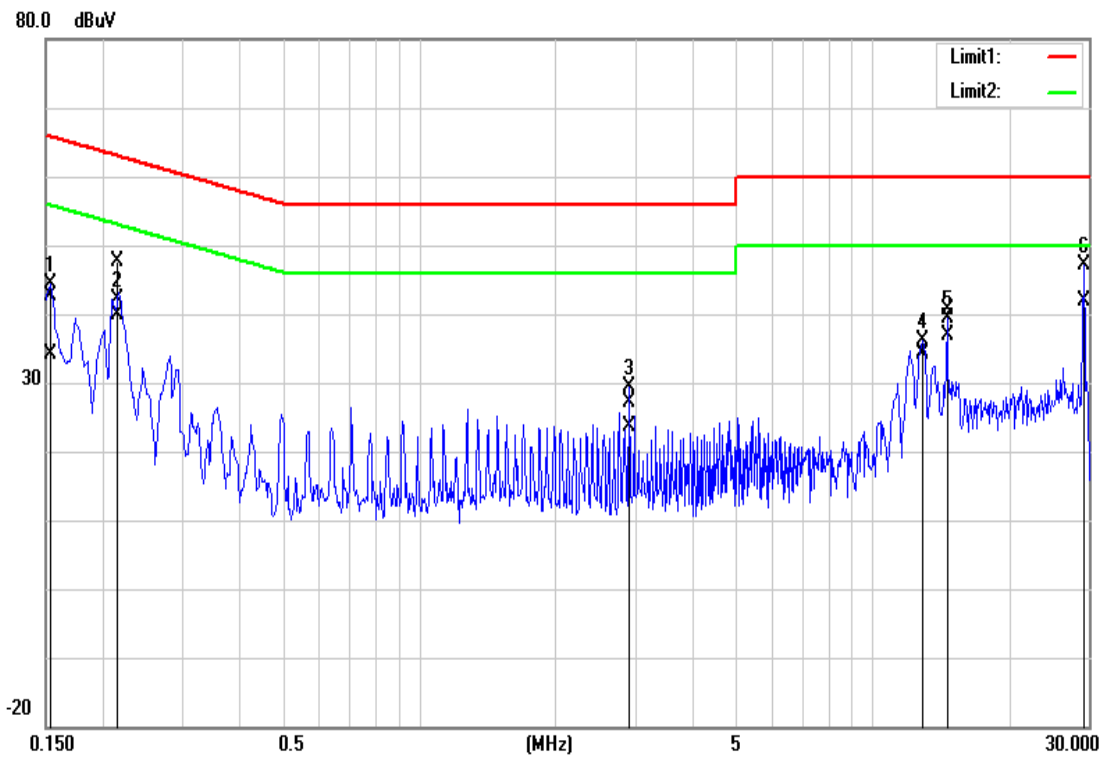

**For Dipole Antenna****Test Data****Operation Mode:** Normal Link**Test Date:**

January 5, 2015

Temperature: 24°C**Tested by:**

Sehni Hu

Humidity: 50% RH

Freq. (MHz)	QP Reading (dBuV)	AV Reading (dBuV)	Corr. factor (dB/m)	QP Result (dBuV/m)	AV Result (dBuV/m)	QP Limit (dBuV)	AV Limit (dBuV)	QP Margin (dB)	AV Margin (dB)	Note
0.1539	34.40	24.61	9.87	44.27	34.48	65.78	55.79	-21.51	-21.31	L1
0.2110	37.60	29.39	9.87	47.47	39.26	63.16	53.17	-15.69	-13.91	L1
2.9089	17.03	13.10	9.98	27.01	23.08	56.00	46.00	-28.99	-22.92	L1
12.8598	23.80	23.37	10.22	34.02	33.59	60.00	50.00	-25.98	-16.41	L1
14.6243	27.86	24.14	10.26	38.12	34.40	60.00	50.00	-21.88	-15.60	L1
29.2500	35.16	29.87	10.74	45.90	40.61	60.00	50.00	-14.10	-9.39	L1
0.1539	34.11	25.47	9.63	43.74	35.10	65.78	55.79	-22.04	-20.69	L2
0.2124	38.20	30.33	9.64	47.84	39.97	63.11	53.11	-15.27	-13.14	L2
2.7670	16.21	13.15	9.76	25.97	22.91	56.00	46.00	-30.03	-23.09	L2
12.9270	25.70	25.12	10.06	35.76	35.18	60.00	50.00	-24.24	-14.82	L2
14.6250	28.54	24.79	10.11	38.65	34.90	60.00	50.00	-21.35	-15.10	L2
29.2490	35.86	30.57	10.64	46.50	41.21	60.00	50.00	-13.50	-8.79	L2

Remark:

- 1. Measuring frequencies from 0.15 MHz to 30MHz.*
- 2. The emissions measured in frequency range from 0.15 MHz to 30MHz were made with an instrument using Quasi-peak detector and average detector.*
- 3. The IF bandwidth of SPA between 0.15MHz and 30MHz was 10 kHz; the IF bandwidth of Test Receiver between 0.15MHz and 30MHz was 9 kHz;*
- 4. L1 = Line One (Live Line) / L2 = Line Two (Neutral Line)*



Test Plots

Conducted emissions (Line 1)

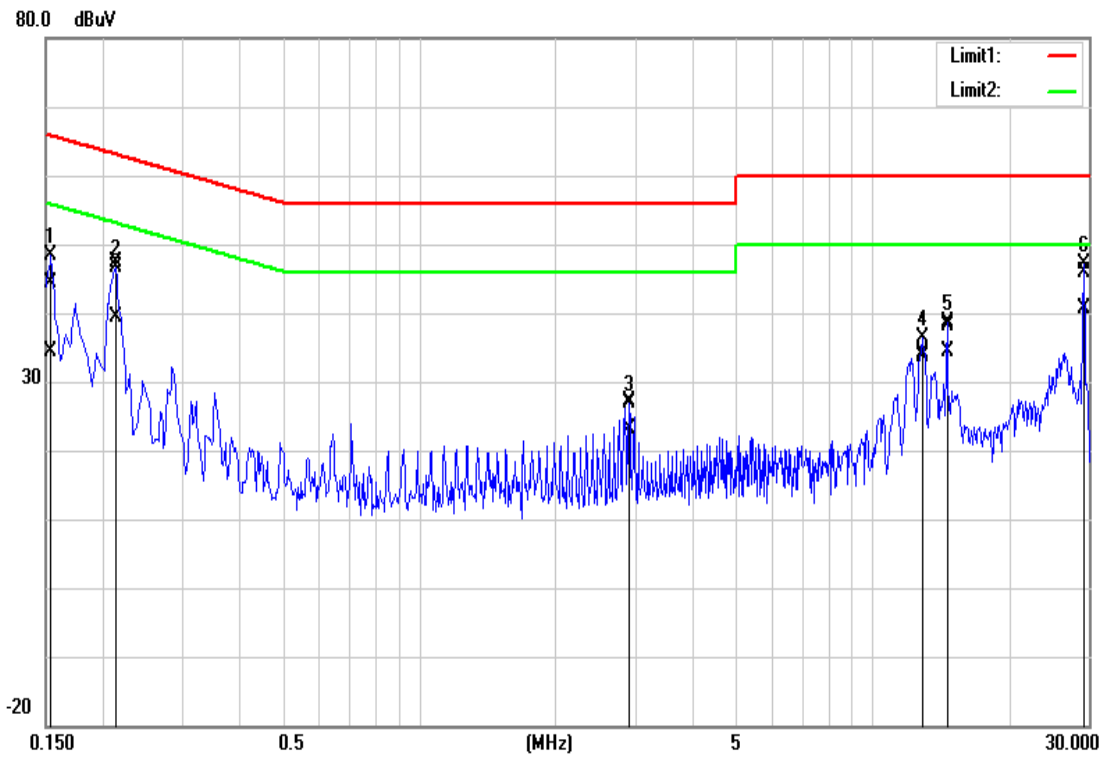

Conducted emissions (Line 2)

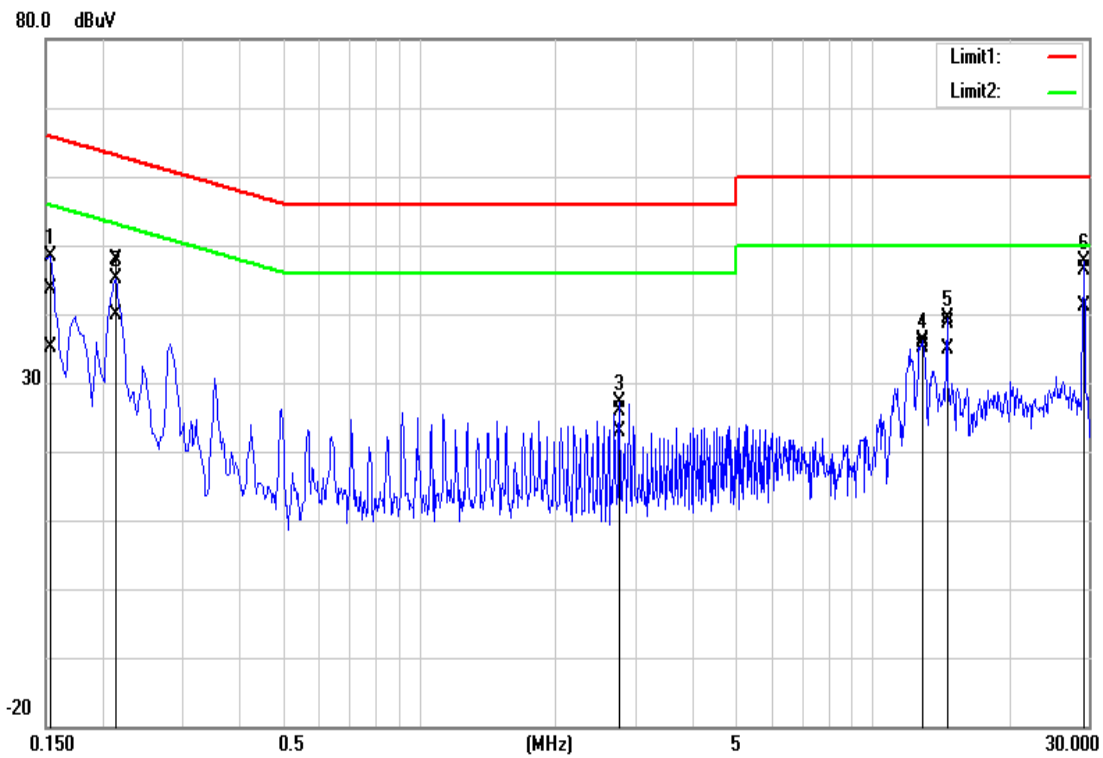



7.7 FREQUENCY STABILITY

LIMIT

According to §15.407(g), manufacturers of U-NII devices are responsible for ensuring frequency stability such that an emission is maintained within the band of operation under all conditions of normal operation as specified in the user's manual.

Test Configuration

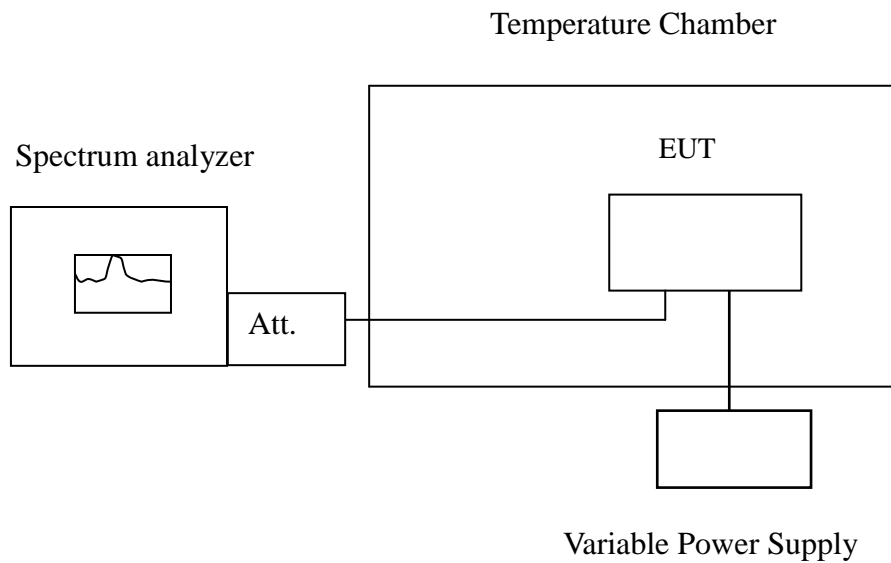

Remark: Measurement setup for testing on Antenna connector



TEST PROCEDURE

The equipment under test was connected to an external AC or DC power supply and input rated voltage. RF output was connected to a frequency counter or spectrum analyzer via feed through attenuators. The EUT was placed inside the temperature chamber. Set the spectrum analyzer RBW low enough to obtain the desired frequency resolution and measure EUT 20°C operating frequency as reference frequency. Turn EUT off and set the chamber temperature to -20°C. After the temperature stabilized for approximately 30 minutes recorded the frequency. Repeat step measure with 10°C increased per stage until the highest temperature of +50°C reached.

TEST RESULTS

No non-compliance noted.

IEEE 802.11a mode / 5180 ~ 5240 MHz:

CH Low

Operating Frequency: 5180 MHz				
Environment Temperature (°C)	Voltage (V)	Measured Frequency (MHz)	Limit Range	Test Result
50	5	5180.009649	5150~5250	Pass
40	5	5180.010537	5150~5250	Pass
30	5	5180.000086	5150~5250	Pass
20	5	5180.009531	5150~5250	Pass
10	5	5180.003892	5150~5250	Pass
0	5	5180.000580	5150~5250	Pass
-10	5	5179.997039	5150~5250	Pass
-20	5	5180.001323	5150~5250	Pass

Operating Frequency: 5180 MHz				
Environment Temperature (°C)	Voltage (V)	Measured Frequency (MHz)	Limit Range	Test Result
20	4.25	5180.01047	5150~5250	Pass
	5	5180.003178	5150~5250	Pass
	5.75	5180.002212	5150~5250	Pass



CH Mid

Operating Frequency: 5220 MHz				
Environment Temperature (°C)	Voltage (V)	Measured Frequency (MHz)	Limit Range	Test Result
50	5	5220.005888	5150~5250	Pass
40	5	5220.006549	5150~5250	Pass
30	5	5220.004778	5150~5250	Pass
20	5	5219.991192	5150~5250	Pass
10	5	5220.009712	5150~5250	Pass
0	5	5220.004359	5150~5250	Pass
-10	5	5220.000760	5150~5250	Pass
-20	5	5219.990132	5150~5250	Pass

Operating Frequency: 5220 MHz				
Environment Temperature (°C)	Voltage (V)	Measured Frequency (MHz)	Limit Range	Test Result
20	4.25	5219.999527	5150~5250	Pass
	5	5219.994812	5150~5250	Pass
	5.75	5219.994693	5150~5250	Pass



CH High

Operating Frequency: 5240 MHz				
Environment Temperature (°C)	Voltage (V)	Measured Frequency (MHz)	Limit Range	Test Result
50	5	5240.001720	5150~5250	Pass
40	5	5240.009224	5150~5250	Pass
30	5	5239.991331	5150~5250	Pass
20	5	5239.999665	5150~5250	Pass
10	5	5240.009823	5150~5250	Pass
0	5	5240.010854	5150~5250	Pass
-10	5	5240.010172	5150~5250	Pass
-20	5	5240.003138	5150~5250	Pass

Operating Frequency: 5240 MHz				
Environment Temperature (°C)	Voltage (V)	Measured Frequency (MHz)	Limit Range	Test Result
20	4.25	5239.994796	5150~5250	Pass
	5	5240.01083	5150~5250	Pass
	5.75	5239.999967	5150~5250	Pass



IEEE 802.11n HT 20 mode / 5180 ~ 5240 MHz:

CH Low

Operating Frequency: 5180 MHz				
Environment Temperature (°C)	Voltage (V)	Measured Frequency (MHz)	Limit Range	Test Result
50	5	5180.002203	5150~5250	Pass
40	5	5179.998005	5150~5250	Pass
30	5	5180.010271	5150~5250	Pass
20	5	5180.009189	5150~5250	Pass
10	5	5180.006122	5150~5250	Pass
0	5	5179.995514	5150~5250	Pass
-10	5	5179.991699	5150~5250	Pass
-20	5	5180.009129	5150~5250	Pass

Operating Frequency: 5180 MHz				
Environment Temperature (°C)	Voltage (V)	Measured Frequency (MHz)	Limit Range	Test Result
20	4.25	5180.002932	5150~5250	Pass
	5	5180.008263	5150~5250	Pass
	5.75	5179.997	5150~5250	Pass



CH Mid

Operating Frequency: 5220 MHz				
Environment Temperature (°C)	Voltage (V)	Measured Frequency (MHz)	Limit Range	Test Result
50	5	5220.005907	5150~5250	Pass
40	5	5220.001078	5150~5250	Pass
30	5	5220.004354	5150~5250	Pass
20	5	5219.998562	5150~5250	Pass
10	5	5219.995991	5150~5250	Pass
0	5	5219.996946	5150~5250	Pass
-10	5	5220.004058	5150~5250	Pass
-20	5	5219.993839	5150~5250	Pass

Operating Frequency: 5220 MHz				
Environment Temperature (°C)	Voltage (V)	Measured Frequency (MHz)	Limit Range	Test Result
20	4.25	5220.00589	5150~5250	Pass
	5	5220.006198	5150~5250	Pass
	5.75	5219.990631	5150~5250	Pass



CH High

Operating Frequency: 5240 MHz				
Environment Temperature (°C)	Voltage (V)	Measured Frequency (MHz)	Limit Range	Test Result
50	5	5239.994985	5150~5250	Pass
40	5	5239.992685	5150~5250	Pass
30	5	5239.991672	5150~5250	Pass
20	5	5240.007865	5150~5250	Pass
10	5	5239.991803	5150~5250	Pass
0	5	5240.009100	5150~5250	Pass
-10	5	5239.996604	5150~5250	Pass
-20	5	5240.001042	5150~5250	Pass

Operating Frequency: 5240 MHz				
Environment Temperature (°C)	Voltage (V)	Measured Frequency (MHz)	Limit Range	Test Result
20	4.25	5240.007613	5150~5250	Pass
	5	5240.000221	5150~5250	Pass
	5.75	5239.991156	5150~5250	Pass



IEEE 802.11n HT 40 mode / 5190 ~ 5230 MHz:

CH Low

Operating Frequency: 5190 MHz				
Environment Temperature (°C)	Voltage (V)	Measured Frequency (MHz)	Limit Range	Test Result
50	5	5190.007693	5150~5250	Pass
40	5	5189.990446	5150~5250	Pass
30	5	5190.005361	5150~5250	Pass
20	5	5190.003162	5150~5250	Pass
10	5	5190.002723	5150~5250	Pass
0	5	5189.995872	5150~5250	Pass
-10	5	5190.004324	5150~5250	Pass
-20	5	5189.994567	5150~5250	Pass

Operating Frequency: 5190 MHz				
Environment Temperature (°C)	Voltage (V)	Measured Frequency (MHz)	Limit Range	Test Result
20	4.25	5190.005061	5150~5250	Pass
	5	5190.010814	5150~5250	Pass
	5.75	5190.009377	5150~5250	Pass



CH High

Operating Frequency: 5230 MHz				
Environment Temperature (°C)	Voltage (V)	Measured Frequency (MHz)	Limit Range	Test Result
50	5	5229.993421	5150~5250	Pass
40	5	5230.008717	5150~5250	Pass
30	5	5230.001452	5150~5250	Pass
20	5	5229.990404	5150~5250	Pass
10	5	5229.994468	5150~5250	Pass
0	5	5229.991051	5150~5250	Pass
-10	5	5230.002620	5150~5250	Pass
-20	5	5230.001910	5150~5250	Pass

Operating Frequency: 5230 MHz				
Environment Temperature (°C)	Voltage (V)	Measured Frequency (MHz)	Limit Range	Test Result
20	4.25	5229.995064	5150~5250	Pass
	5	5230.0049	5150~5250	Pass
	5.75	5229.996917	5150~5250	Pass



IEEE 802.11ac80 mode / 5210 MHz:

Operating Frequency: 5210 MHz				
Environment Temperature (°C)	Voltage (V)	Measured Frequency (MHz)	Limit Range	Test Result
50	5	5210.007203	5150~5250	Pass
40	5	5210.003347	5150~5250	Pass
30	5	5210.005473	5150~5250	Pass
20	5	5209.992217	5150~5250	Pass
10	5	5210.004190	5150~5250	Pass
0	5	5209.997134	5150~5250	Pass
-10	5	5210.000749	5150~5250	Pass
-20	5	5210.003055	5150~5250	Pass

Operating Frequency: 5210 MHz				
Environment Temperature (°C)	Voltage (V)	Measured Frequency (MHz)	Limit Range	Test Result
20	4.25	5210.001203	5150~5250	Pass
	5	5210.002338	5150~5250	Pass
	5.75	5209.99694	5150~5250	Pass