



Underwriters Laboratories Inc.

www.ul.com/emc
www.ulc.co.kr

Project No.: 12CA08535
File No.: MC16340
Report No.: 12CA08535-5-FCC
Date: August 17, 2013
Model No.: FXRD-1417WA
FCC ID.: RYK-WPEA121N
IC Number: 6158A-WPEA121NW

RF Test Report

in accordance with
FCC Part 15 Subpart E §15.407 and IC RSS-210 Issue 8

for

Detector

Vieworks Co., Ltd.

#601 ~ 610, Suntechcity 2, 307-2, Sangdaewon-dong Jungwon-Gu
Seongnam-city Gyeonggi-do, 462-806, South Korea

Copyright © 2005 Underwriters Laboratories Inc.

Underwriters Laboratories Inc. authorizes the above-named company to reproduce this Report provided it is reproduced in its entirety.

Only those products bearing the UL Mark should be considered as being covered by UL.

UL Korea, Ltd
33rd FL, Gangnam Finance Center, 737
Yeoksam-dong, Gangnam-gu, Seoul
135-984 Korea
Tel: +82.2.2009.9000, Fax:+82.2.2009.9405

An organization dedicated
to public safety and committed to
quality service for over 100 years

Summary of Test Results:

The following tests were performed on a sample submitted for evaluation of compliance with FCC Part 15 C Section 15.247 and IC RSS-210 Issue 8.

No	Reference Clause No.		FCC Part15 Subpart C Conformance Requirements	Result Verdict	Remark
	FCC Rule	IC Rule			
1	15.403(i)	A9.2	26dB & 99% Bandwidth Measurement	N/A	*Note ²
2	15.407(a)	A9.2	Power Spectral Density Measurement	N/A	*Note ²
3	-	-	Average Power Measurement	-	-
4	15.407(a)	A9.2	Output Power Measurement	N/A	*Note ²
5	15.407(b)	A9.3	Conducted Spurious Emission Measurement	N/A	*Note ²
6	15.407(b)	A9.3	Band Edges Measurement	N/A	*Note ²
7	15.407(g)	A9.5	Frequency Stability Measurement	N/A	*Note ²
8	15.207	Gen 7.2.2	AC Conducted Emission Measurement	N/A	*Note ³
9	15.407(c)	A9.5	Automatically Discontinue Transmission	N/A	*Note ²
10	15.205(a)	-	Restricted bands of operation	Complied	-
11	15.209(a)	-	Radiated emission limits, general requirements	Complied	-

*Note ¹: N/T=Not Tested, N/A=Not Applicable
 *Note ²: Test was performed by modular transmitter (FCC ID: RYK-WPEA121N, Test Report no. FR131667AN issued on May.02, 2011 by Sporton International Inc.)
 *Note ³: The EUT is battery operating only.

The modular reports allow for a maximum gain dipole antenna to be 2.0dBi/2.0 dBi in the 2.4GHz band and 5GHz bands. This host device uses a PCB antenna with a maximum gain of 4.7dBi in the 2.4GHz band and 2.2dBi in the 5GHz bands, therefore the limits used for the output power and power spectral density in the modular reports for 5GHz operations (DTS and NII) show compliance for the host using these antennas as they are of equal or lower gain. For 2.4GHz operations the composite gain for 2x2 beamforming modes is 7.7dBi. the output power limit for a 7.7dBi antenna is 28.3dBm. the maximum measured output power was 27.19dBm which complies with this limit of 28.3dBm. All bandwidth, power and power density measurements were made in accordance with the latest FCC KDB guidance documents for DTS and NII transmitters.

Radiated spurious emissions were tested for the host system so the different antenna type is covered by the system level tests.

Conclusion:

The tests listed in the Summary of Testing section of this report have been performed and the results recorded by UL Korea Ltd. in accordance with the procedures stated in each test requirement and specification. The test list was determined by the Applicant as being applicable to the Equipment Under Test. As a result, the subject product has been verified to comply or not comply as noted in the Summary of Testing with each test specification. The test results relate only to the items tested.



Witness tested by
 Hongsuk Oh, WiSE Associate Project Engineer
 UL Verification Services- 3014ASEO
 UL Korea Ltd.
 Aug. 17, 2013

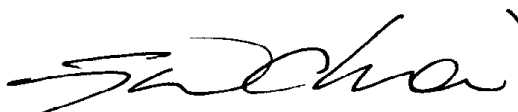

Reviewed by
 Jeawoon, Choi, WiSE Operations Manager
 UL Verification Services- 3014ASEO
 UL Korea Ltd.
 Aug. 17, 2013

Test Report Details

Test Report No: 12CA08535-5-FCC

Witness Tests Performed By: UL Korea Ltd.
33rd FL. GFC Center, 737 Yeoksam-dong, Gangnam-gu, Seoul, 135-984, Korea

Test Site: KES Co., Ltd.
477-6, Hageo-ri, Yeosu-eup, Yeosu-gun, Gyeonggi-do, 469-803, Korea

Applicant: Vieworks Co., Ltd.
#601 ~ 610, Suntechcity 2, 307-2, Sangdaewon-dong Jungwon-Gu Seongnam-city Gyeonggi-do, 462-806, South Korea

Applicant Contact: Jeong-mi Kim

Title: Manager

Phone: +82-70-7011-6176

Fax: +82-31-737-4953

FCC ID: RYK-WPEA121N

IC Number: 6158A-WPEA121NW

E-mail: salangshy@vieworks.com

Product Type: X-ray Detector

Model Number: FXRD-1417WA

Multiple Model Name: FXRD-1417WB
The manufacturer has declared to all the multiple model names into the basic model without any further evaluation by UL

Trademark 

Sample Serial Number: N/A

Test standards: FCC Part 15 C Section 15.407 and IC RSS-210 Issue 8

Sample Serial Number: N / A

Sample Receive Date: 2013.07.09

Testing Date: 2013.07.30 ~ 2013.08.09

Test Report Date: 2013.08.17

Overall Results: Pass

UL Korea Ltd. reports apply only to the specific test samples and test results submitted for UL's review. All samples tested were in good operating condition throughout the entire test program. It is the manufacturer's responsibility to assure that additional production units of this model are manufactured with identical electrical and mechanical components. UL Korea Ltd. shall have no liability for any deductions, inferences or generalizations drawn by the client or others from UL Korea Ltd. issued reports. This report shall not be used to claim, constitute or imply product certification, approval, or any agency of the National Authorities. This report may contain test results that are not covered by the NVLAP or KOLAS accreditation.

Report Directory

1.	GENERAL PRODUCT INFORMATION	5
1.1.	EQUIPMENT DESCRIPTION	5
1.2.	DETAILS OF TEST EQUIPMENT (EUT)	5
1.3.	EQUIPMENT CONFIGURATION	5
1.4.	TECHNICAL DATA.....	5
1.5.	ANTENNA INFORMATION	5
1.6.	EQUIPMENT TYPE :	6
1.7.	TECHNICAL DESCRIPTIONS AND DOCUMENTS	6
1.8.	EQUIPMENT MARKING PLATE.....	6
1.9.	DESCRIPTION OF ADDITIONAL MODEL NAME.....	7
2.	TEST SPECIFICATION.....	7
3.	TEST CONDITIONS	7
3.1.	EQUIPMENT USED DURING TEST	7
3.2.	INPUT/OUTPUT PORTS	7
3.3.	POWER INTERFACE	7
3.4.	OPERATING FREQUENCIES	8
3.5.	OPERATION MODES	8
3.6.	TEST CONFIGURATIONS	9
3.7.	LIST OF TEST EQUIPMENT.....	9
4.	OVERVIEW OF TECHNICAL REQUIREMENTS	10
4.1.	ANTENNA REQUIREMENT	10
5.	TEST RESULTS.....	11
5.1.	TRANSMITTER RADIATED SPURIOUS EMISSIONS	11

1. General Product Information

1.1. Equipment Description

Wireless communication is established between the ViVIX-S Wireless detector and System Control Unit. The ViVIX-S system is compliant with IEEE 802.11a/b/g/n (2.4 GHz / 5 GHz).

1.2. Details of Test Equipment (EUT)

- Equipment Type : X-ray Detector
- Model No. : FXRD-1417WA, FXRD-1417WB
- Operating characteristic : Short range wireless device operating in the 2400 – 2483.5 ISM frequency band
- Manufacturer : Vieworks Co., Ltd.
 #601 ~ 610, Suntechcity 2, 307-2, Sangdaewon-dong Jungwon GuSeongnam-city
 Gyeonggi-do, 462-806, South korea

1.3. Equipment Configuration

The EUT is consisted of the following component provided by the manufacturer.

Use*	Product Type	Manufacturer	Model	Comments
EUT	X-ray Detector	Vieworks Co., Ltd.	FXRD-1417WA	S/N : D3CABH001
EUT	Battery	Vieworks Co., Ltd.	FXRB-01A	S/N : B1-AAAT002
*Note: Use = EUT - Equipment Under Test, AE - Auxiliary/Associated Equipment. SIM - Simulator (Not Subjected to Test)				

1.4. Technical Data

Item	System Control Unit
Frequency Ranges	5180 ~ 5240 MHz, 5190 ~ 5230 MHz, 5745~5825 MHz, 5755 ~ 5795 MHz
Kind of modulation (s)	OFDM, BPSK, QPSK, 16QAM, 64QAM
Channel	5180 ~ 5240 MHz: 4 channel (11a/n_HT20– Non DFS) 5190 ~ 5230 MHz: 2 channel (11n_HT40– Non DFS) 5745~5825 MHz: 5 channel (11a/n_HT20– Non DFS) 5755 ~ 5795 MHz: 2 channel (11n_HT40 – Non DFS)
Antenna information	Integral type(PCB antenna)
Working temperature	-20 ~ 70 °C
Supply Voltage	DC +24 V
*Note: All the technical data described above were provided by the manufacturer.	

1.5. Antenna Information

Item	System Control Unit
Antenna Model Name	AEi-2450/5500DP-C1.13[Vieworks]
Antenna Type	PCB antenna
Manufacturer	Viework Co., Ltd.
GAIN(dBi) - 2.4GHz	4.66 dBi

GAIN(dBi) - 5GHz	2.19 dBi
Polarization	Isotropic
*Note: All the technical data described above were provided by the manufacturer.	

1.6. Equipment Type :

- Radio and ancillary equipment for fixed or semi-fixed use
- Radio and ancillary equipment for vehicular mounted use
- Radio and ancillary equipment for portable or handheld use

- Stand alone Host connected

- Self contained single unit Module with associated connection or interface

1.7. Technical descriptions and documents

No.	Document Title and Description
1	User Manual
*Note: The following document was provided by the manufacturer.	

1.8. Equipment Marking Plate

<div style="display: flex; justify-content: space-between;"> <div style="text-align: center;"> <p>ViVIX-S Wireless</p> </div> <div style="text-align: center;"> <p>CE 0434</p> </div> <div style="text-align: center;"> </div> </div> <p style="text-align: center;">Digital Imaging System</p> <hr/> <p>Part No.: FXRD-1417WA SN:</p> <div style="display: flex; justify-content: space-between;"> <div style="text-align: center;"> Follow Instruction for use </div> <div style="text-align: center;"> Rating: 24V \equiv Max. 0.5A (Use only with FXRS-03A) </div> </div> <p>Date of manufacture: _____ RN: _____</p> <div style="display: flex; justify-content: space-between; font-size: small;"> <div style="width: 30%;"> <p>CLASSIFIED Medical Equipment UL60601-1/CAN.CSA CSS.2 NO.601.1 FACTORY ID : VWF2 47CE</p> </div> <div style="width: 30%;"> <p>Contain FCC ID : RYK-WPEA-121N Contains IC Number : 6158A-WPEA121NW CMIIT ID: _____</p> </div> <div style="width: 30%;"> <p> KCC-RMM-VJM -FXRD1417W</p> </div> </div> <div style="display: flex; justify-content: space-around; align-items: center; font-size: x-small;"> <div style="text-align: center;"> Electric Shock</div> <div style="text-align: center;"> 5.15-5.35GHz is indoor use only.</div> </div> <hr/> <div style="display: flex; align-items: center;"> <div style="font-size: 2em; margin-right: 5px;">Rx</div> <div> <p>CAUTION: Federal law restricts this device to sale by or on the order of a physician or a licensed practitioner.</p> </div> </div> <hr/> <div style="display: flex; align-items: center;"> <div style="width: 20px; height: 20px; background-color: black; margin-right: 5px;"></div> <div style="font-size: small;"> <p>Manufacturer: Vieworks Co., Ltd. #107~108, 601~610, Suntechcity II, 52 Sagimakgol-ro, Jungwon-gu, Seongnam-si, Gyeonggi-do, 462-736, South Korea</p> </div> </div> <p style="text-align: right; font-size: x-small;">MADE IN KOREA</p>	<div style="display: flex; justify-content: space-between;"> <div style="text-align: center;"> <p>ViVIX-S Wireless</p> </div> <div style="text-align: center;"> <p>CE 0434</p> </div> <div style="text-align: center;"> </div> </div> <p style="text-align: center;">Digital Imaging System</p> <hr/> <p>Part No.: FXRD-1417WB SN:</p> <div style="display: flex; justify-content: space-between;"> <div style="text-align: center;"> Follow Instruction for use </div> <div style="text-align: center;"> Rating: 24V \equiv Max. 0.5A (Use only with FXRS-03A) </div> </div> <p>Date of manufacture: _____ RN: _____</p> <div style="display: flex; justify-content: space-between; font-size: small;"> <div style="width: 30%;"> <p>CLASSIFIED Medical Equipment UL60601-1/CAN.CSA CSS.2 NO.601.1 FACTORY ID : VWF2 47CE</p> </div> <div style="width: 30%;"> <p>Contain FCC ID : RYK-WPEA-121N Contains IC Number : 6158A-WPEA121NW CMIIT ID: _____</p> </div> <div style="width: 30%;"> <p> KCC-RMM-VJM -FXRD1417W</p> </div> </div> <div style="display: flex; justify-content: space-around; align-items: center; font-size: x-small;"> <div style="text-align: center;"> Electric Shock</div> <div style="text-align: center;"> 5.15-5.35GHz is indoor use only.</div> </div> <hr/> <div style="display: flex; align-items: center;"> <div style="font-size: 2em; margin-right: 5px;">Rx</div> <div> <p>CAUTION: Federal law restricts this device to sale by or on the order of a physician or a licensed practitioner.</p> </div> </div> <hr/> <div style="display: flex; align-items: center;"> <div style="width: 20px; height: 20px; background-color: black; margin-right: 5px;"></div> <div style="font-size: small;"> <p>Manufacturer: Vieworks Co., Ltd. #107~108, 601~610, Suntechcity II, 52 Sagimakgol-ro, Jungwon-gu, Seongnam-si, Gyeonggi-do, 462-736, South Korea</p> </div> </div> <p style="text-align: right; font-size: x-small;">MADE IN KOREA</p>
---	---

1.9. Description of additional model name

Model name	Model name Designation	Description of design
FXRD-1417WB	Identical to FXRD-1417WA	Depending on scintillator of detector, the model name is different. Scintillator is Csi(TI), model name is FXRD-1417WA. And also when the scintillator is Gadox, model name is FXRD-1417WB.

2. Test Specification

The following test specifications and standards have been applied and used for testing.

1) FCC Part 15 C Section 15.247

Operation within the bands 902–928 MHz, 2400–2483.5 MHz, and 5725–5850 MHz

2) ANSI C63.4:2009

American National Standard for Methods of Measurement of Radio- Noise Emissions from Low-Voltage Electrical and Electronic Equipment in the Range of 9 kHz to 40 GHz

3) KDB 789033 D01 UNII General Test Procedures v01r03

Guidelines for Compliance Testing of Unlicensed National Information Infrastructure (U-NII) Devices Part 15, Subpart E

3. Test Conditions

3.1. Equipment Used During Test

Use*	Product Type	Manufacturer	Model	Comments
EUT	X-ray Detector	Vieworks Co., Ltd.	FXRD-1417WA	S/N : D3CABH001
EUT	Battery	Vieworks Co., Ltd.	FXRB-01A	S/N : B1-AAAT002
AE	System control unit	Vieworks Co., Ltd.	FXRS-03A	S/N : S2-ABH-D002
AE	Note PC	Lenovo	X2000	-

*Note: Use = EUT - Equipment Under Test, AE - Auxiliary/Associated Equipment. SIM - Simulator (Not Subjected to Test)

3.2. Input/Output Ports

Port #	Name	Type*	Cable Max. >3m	Shielded	Comments
1	Signal port	I/O	15 m	Shielded	SCU - X-Ray detector Cable

Note 1: All the interface cables and Power Cable have been provided by the manufacturer

Note 2: *AC = AC Power Port DC = DC Power Port N/E = Non-Electrical
 I/O = Signal Input or Output Port (Not Involved in Process Control)
 TP = Telecommunication Ports

3.3. Power Interface

Mode #	Voltage (V)	Current (A)	Power (W)	Frequency (DC/AC-Hz)	Comments
Rated	DC +24 V	Max. 0.5 A	-	DC	Rated of Battery
1	DC +24 V	-	-	DC	

3.4. Operating Frequencies

Mode #	Frequency tested
1	Operating frequency range : 5 180 MHz ~ 5 240 MHz (11a & 11n_HT20) 3 channels in the Transmitter modes of 11b/g/n-HT20 are tested. - Low : 5 180 MHz / CH = 36 - Mid : 5 220 MHz / CH = 44 - Top : 5 240 MHz / CH= 48
2	Operating frequency range : 5 190 MHz ~ 5 230 MHz (11n_HT40) 3 channels in the Transmitter modes of 11n-HT40 are tested. - Low : 5 190 MHz / CH = 38 - Top : 5 230 MHz / CH= 46

3.5. Operation Modes

Mode #	Description
1	Carrier on mode: Signal from the RF module was generated continuously for the representative channels (Low, Mid, High) by the test program incorporated
<p>*Note:</p> <ol style="list-style-type: none"> The worst-case condition is determined by the baseline measurement of rf output power of the modular transmitter test report. The worst-case channel was determined as the channel with highest output power. Output power from the device during the radiated spurious measurements are within expected tolerance of the module test results to justify using the original conducted antenna port measurements for the module(average power). -. 11a : 12.0 dBm, 11an-HT20 : 14.0 dBm, 11an-HT40: 15.0 dBm for each channel -. 11a/n-HT20/40 : 16.0 dBm for each channel. 	

3.6. Test Configurations

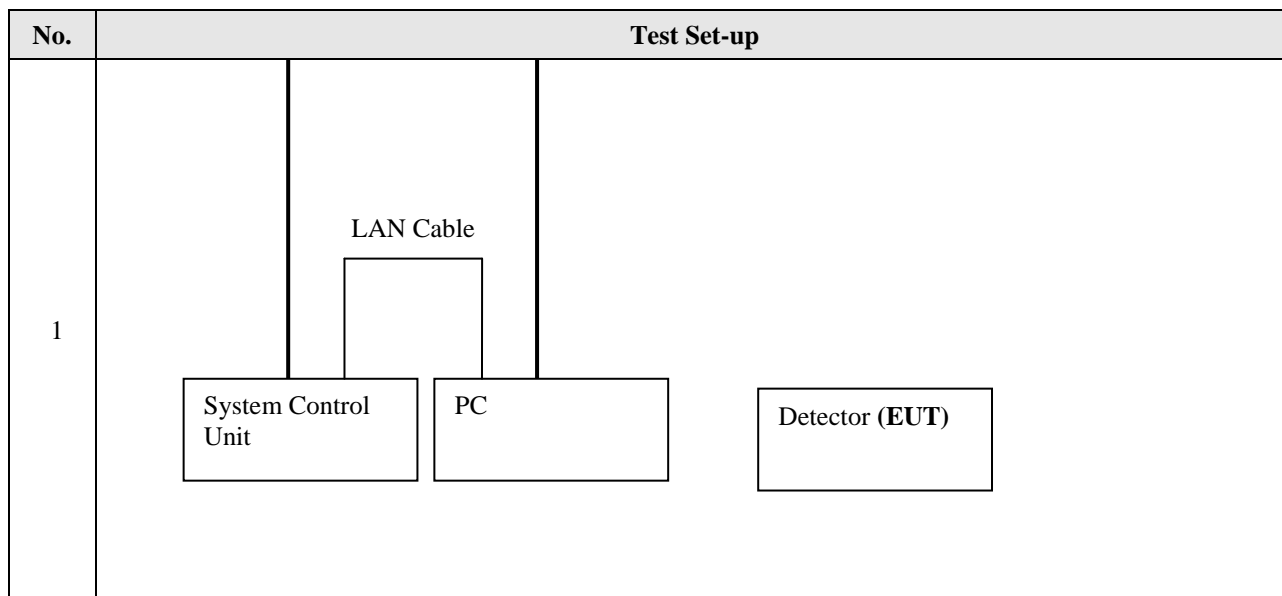

3.7. List of Test Equipment

No	Description	Manufacturer	Model	Identifier	Cal. Due
1	Spectrum Analyzer	R&S	FSV30	100736	2013.01.10
2	8360B Series Swept Signal Generator	HP	83630B	3844A00786	2013.06.06
3	Low Pass Filter	Mini-Circuits	NLP-1200+	V8979400903-1	2013.07.11
4	High Pass Filter	Wainwright Instrument	WHK6.0/18G-10SS	11	2013.07.07
5	High Pass Filter	Wainwright Instrument	WHJS3000-10TT	1	2013.01.10
6	Trilog-BroadBand Antenna	Schwarzbeck	VULB 9168	9168-462	2013.10.25
7	Horn Antenna	A.H.	SAS-571	414	2013.03.22
8	Preamplifier	R&S	SCU18	0117	2013.01.12

4. Overview of Technical requirements

The following essential requirements and test specifications are relevant to the presumption of conformity FCC Part 15 C Section 15.407			
Reference Clause No.	Essential technical requirements	Test method	Reported
15.205(a)	Restricted bands of operation	Note 1	[X]
15.209(a)	Radiated emission limits, general requirements		[X]
15.203	Antenna Requirement		[X]

Note 1: The measurement procedures described in the American National Standard for Methods of Measurement of Radio-Noise Emission from Low-Voltage Electrical and Electronic Equipment in the Range of 9 kHz to 40 MHz (ANSI C63.4-2009), the guidance provided in KDB 558074 and KDB 662911 D01 v02r01/D02 v01 were used in the measurement of the DUT.

Note 2: This device use already certified module so that the below specified test items are not tested in the end product evaluation. (TX Module FCC ID : RYK-WPEA121N, Test Report no. FR131667AN issued on May.02,2011 by Sporton International Inc.)

- . 26dB bandwidth
- . Tx Output Power
- . Band edge
- . Tx Spectral Power Density
- . Conducted Spurious Emission
- . Peak Excursion Ratio
- . Frequency Stability
- . Discontinuous Transmission

4.1. Antenna Requirement

4.1.1. Standard Applicable

For intentional device, according to FCC 47 CFR Section §15.203, an intentional radiator shall be designed to ensure that no antenna other than that furnished by the responsible party shall be used with the device. And according to FCC 47 CFR Section § 15.247 (b), if transmitting antennas of directional gain greater than 6 dBi are used, the power shall be reduced by the amount in Db that the gain of the antenna exceeds 6 dBi.

4.1.2. Antenna Connected Construction

The antenna used of this product is dipole Antenna Assembly and peak max gain of each antennas as below. Antenna is permanently installed in the end product enclosure and no user exchange is allowed.

Band	2412 – 2462 MHz	5745 – 5825 MHz 5180 – 5320 MHz 5500 – 5700 MHz
Antenna Gain (dBi)	3.6 dB Max.	4.7 dB Max.

5. Test Results

5.1. Transmitter radiated spurious emissions spurious emission

TEST: Transmitter radiated spurious emissions and Conducted spurious emission		
Method	Radiated emissions from the EUT were measured according to ANSI C63.4-2009 procedure. 1. The EUT was placed on the top of a rotating table 0.8 meters above the ground at a 3 meter anechoic chamber test site. The table was rotated 360 degrees to determine the position of the highest radiation. The antenna is varied from 1 to 4 meters above the ground to find the maximum field strength. Measurement are made with both horizontal and vertical polarizations For fundamental investigation, the EUT was positioned for 3 orthogonal orientations. 2. For measurement below 1GHz, the resolution bandwidth is set to 100 kHz for peak detection or 120kHz for quasi-peak detection measurements. Peak detection is used unless otherwise noted as quasi-peak. 3. For measurement above 1GHz, the resolution bandwidth is set to 1 MHz and video bandwidth is set to 1 MHz for peak measurement and 10 Hz for average measurement. 4. For 2.4GHz transmitter measurement, the spectrum from 30 MHz to 26GHz is investigated for Low, Mid and High channels. For 5 GHz transmitter measurement, the spectrum from 30 MHz to 40GHz is investigated for Low, Mid and High channels.	
Supplementary information: Radiated emission which fall in the restricted bands must also comply with FCC section 15.209.		
Reference Clause	Part15 C Section 15.407 (b)	
Parameters recorded during the test	Laboratory Ambient Temperature	22 °C
	Relative Humidity	36 %
	Frequency range	Measurement Point
Fully configured sample scanned over the following frequency range	30MHz to 10 th harmonics	Enclosure Port

Configuration Settings

Test Item	Power Interface Mode # (See Section 3.3)	Test Configurations Mode # (See Section 3.6)	EUT Operation Mode # (See 3.5)
Radiated Spurious emission	1	1	1
Conducted Spurious emission	N/T	N/T	N/T
Supplementary information: None			

Limits

For transmitters operating in the 5.15 ~ 5.25 GHz band: all emissions outside of the 5.15 ~ 5.35 GHz band shall not exceed an EIRP of -27 dBm/MHz.

For transmitters operating in the 5.25 ~ 5.35 GHz band: all emissions outside of the 5.15 ~ 5.35 GHz band shall not exceed an EIRP of -27 dBm/MHz.

Devices operating in the 5.25 ~ 5.35 GHz band that generate emissions in the 5.15 ~ 5.25 GHz band must meet all applicable technical requirements for operation in the 5.15 ~ 5.25 GHz band (including indoor use) or alternatively meet an out-of-band emission EIRP limit of -27 dBm/MHz in the 5.15 ~ 5.25 GHz band.

For transmitters operating in the 5.47 ~ 5.725 GHz band: all emissions outside of the 5.47 ~ 5.725 GHz band shall not exceed an EIRP of -27 dBm/MHz.

According to § 15.209(a), Except as provided elsewhere in this Subpart, the emissions from an intentional radiator shall not exceed the field strength levels specified in the following table:

Frequency (MHz)	Distance (meters)	Field Strength (dBuV/m)	Field Strength (uV/m)
30-88	3	40.0	100
88-216	3	43.5	150
216-960	3	46.0	200
Above 960	3	54.0	500

5.1.1. Radiated Spurious Emissions for Below 1 GHz

Measurement method : Radiated Conducted
 Mode of operation : Continuous Wave
 Power setting : Max. Power condition declared by the manufacturer
 Worst case configuration : 5GHz_HT40

Table 1. Test data for Radiated emission for Below 1 GHz

Radiated emissions			Ant	Correction factors			Total	Limit	
Frequency (MHz)	Reading (dBuV)	Detect Mode	Pol.	Distance (dB)	AF (dB/m)	Amp gain+CL (dB)	Actual (dBuV/m)	Limit (dBuV/m)	Margin (dB)
124.8	24.87	Q.P.	H	N/A	11.58	2.10	38.55	43.50	4.95
145.6	22.07	Q.P.	V	N/A	12.86	2.33	37.25	43.50	6.25
167.1	22.33	Q.P.	H	N/A	12.72	2.50	37.55	43.50	5.95
180.4	24.83	Q.P.	V	N/A	11.61	2.62	39.05	43.50	4.45
734.5	15.48	Q.P.	H	N/A	21.37	6.00	42.85	46.00	3.15
734.5	14.92	Q.P.	V	N/A	21.37	6.00	42.29	46.00	3.71

Supplementary information:

-. The frequency spectrum from 30 MHz to 1 000 MHz was investigated. Emission levels are not reported much lower than the limits by over 30 dB. All reading values are peak values.

Remark

- a. To get a maximum emission level from the EUT, the EUT was moved throughout the x-axis, Y-axis and Z-axis. The worst case is Y-axis.
- b. Actual = Reading + AF + AMP + CL (AF : Antenna factor, AMP : Amp gain, CL : Cable loss)
- c. Distance factor = 20log(Measurement distance / The measured distance)
- d. Margin = Limit (dBuV/m) - Actual (dBuV/m)

5.1.2. Radiated Spurious Emissions for Above 1 GHz

Measurement method : Radiated Conducted
 Mode of operation : Continuous Wave
 Power setting : Max. Power condition declared by the manufacturer
 Worst case configuration : 11a- 54 bps , 11n_HT20 – MCS7,11n_HT40 – MCS7

802.11a_Non DFS (5 180 – 5 240 MHz)

Table 2. Low Channel (5 180 MHz)

Radiated emissions			Ant	Correction factors			Total	Limit	
Frequency (MHz)	Reading (dBuV)	Detect Mode	Pol.	Distance (dB)	AF (dB/m)	Amp gain+CL (dB)	Actual (dBuV/m)	Limit (dBuV/m)	Margin (dB)
10360	46.78	Peak	H	N/A	37.58	-33.70	50.66	74.00	23.34
10360	35.43	Average	H	N/A	37.58	-33.70	39.31	54.00	14.69
10360	46.82	Peak	V	N/A	37.58	-33.70	50.70	74.00	23.30
10360	39.44	Average	V	N/A	37.58	-33.70	43.32	54.00	10.68

Table 3. Middle Channel (5 220 MHz)

Radiated emissions			Ant	Correction factors			Total	Limit	
Frequency (MHz)	Reading (dBuV)	Detect Mode	Pol.	Distance (dB)	AF (dB/m)	Amp gain+CL (dB)	Actual (dBuV/m)	Limit (dBuV/m)	Margin (dB)
10440	44.78	Peak	H	N/A	37.67	-33.66	48.79	74.00	25.21
10440	39.92	Average	H	N/A	37.67	-33.66	43.93	54.00	10.07
10440	44.54	Peak	V	N/A	37.67	-33.66	48.55	74.00	25.45
10440	39.35	Average	V	N/A	37.67	-33.66	43.36	54.00	10.64

Table 4. High Channel (5 240 MHz)

Radiated emissions			Ant	Correction factors			Total	Limit	
Frequency (MHz)	Reading (dBuV)	Detect Mode	Pol.	Distance (dB)	AF (dB/m)	Amp gain+CL (dB)	Actual (dBuV/m)	Limit (dBuV/m)	Margin (dB)
10480	43.94	Peak	H	N/A	37.61	-33.64	47.91	74.00	26.09
10480	33.70	Average	H	N/A	38.11	-33.64	38.17	54.00	15.83
10480	44.46	Peak	V	N/A	38.11	-33.64	48.93	74.00	25.07
10480	30.31	Average	V	N/A	38.11	-33.64	34.78	54.00	19.22

11n_HT20

Table 5. Low Channel (5 180 MHz)

Radiated emissions			Ant	Correction factors			Total	Limit	
Frequency (MHz)	Reading (dBuV)	Detect Mode	Pol.	Distance (dB)	AF (dB/m)	Amp gain+CL (dB)	Actual (dBuV/m)	Limit (dBuV/m)	Margin (dB)
10360	46.22	Peak	H	N/A	37.58	-33.70	50.10	74.00	23.90
10360	36.06	Average	H	N/A	37.58	-33.70	39.94	54.00	14.06
10360	44.69	Peak	V	N/A	37.58	-33.70	48.57	74.00	25.43
10360	35.53	Average	V	N/A	37.58	-33.70	39.41	54.00	14.59

Table 6. Middle Channel (5 220 MHz)

Radiated emissions			Ant	Correction factors			Total	Limit	
Frequency (MHz)	Reading (dBuV)	Detect Mode	Pol.	Distance (dB)	AF (dB/m)	Amp gain+CL (dB)	Actual (dBuV/m)	Limit (dBuV/m)	Margin (dB)
10440	45.68	Peak	H	N/A	37.67	-33.66	49.69	74.00	24.31
10440	33.27	Average	H	N/A	37.67	-33.66	37.28	54.00	16.72
10440	45.45	Peak	V	N/A	37.67	-33.66	49.46	74.00	24.54
10440	33.84	Average	V	N/A	37.67	-33.66	37.85	54.00	16.15

Table 7. High Channel (5 240 MHz)

Radiated emissions			Ant	Correction factors			Total	Limit	
Frequency (MHz)	Reading (dBuV)	Detect Mode	Pol.	Distance (dB)	AF (dB/m)	Amp gain+CL (dB)	Actual (dBuV/m)	Limit (dBuV/m)	Margin (dB)
10480	42.96	Peak	H	N/A	37.61	-33.64	46.93	74.00	27.07
10480	32.44	Average	H	N/A	38.11	-33.64	36.91	54.00	17.09
10480	44.36	Peak	V	N/A	38.11	-33.64	48.83	74.00	25.17
10480	33.21	Average	V	N/A	38.11	-33.64	37.68	54.00	16.32

11n_HT40

Table 8. Low Channel (5 190 MHz)

Radiated emissions			Ant	Correction factors			Total	Limit	
Frequency (MHz)	Reading (dBuV)	Detect Mode	Pol.	Distance (dB)	AF (dB/m)	Amp gain+CL (dB)	Actual (dBuV/m)	Limit (dBuV/m)	Margin (dB)
10380	47.32	Peak	H	N/A	37.55	-33.69	51.18	74.00	22.82
10380	40.69	Average	H	N/A	37.55	-33.69	44.55	54.00	9.45
10380	47.98	Peak	V	N/A	37.55	-33.69	51.84	74.00	22.16
10380	40.82	Average	V	N/A	37.55	-33.69	44.68	54.00	9.32

Table 9. High Channel (5 230 MHz)

Radiated emissions			Ant	Correction factors			Total	Limit	
Frequency (MHz)	Reading (dBuV)	Detect Mode	Pol.	Distance (dB)	AF (dB/m)	Amp gain+CL (dB)	Actual (dBuV/m)	Limit (dBuV/m)	Margin (dB)
10460	44.32	Peak	H	N/A	38.16	-33.65	48.83	74.00	25.17
10460	31.27	Average	H	N/A	37.62	-33.65	35.24	54.00	18.76
10460	47.13	Peak	V	N/A	37.62	-33.65	51.10	74.00	22.90
10460	33.06	Average	V	N/A	37.62	-33.65	37.03	54.00	16.97

Supplementary information:

-. Measuring frequencies from 1 GHz to the 10th harmonic of highest fundamental Frequency. Radiated emissions measured in frequency above 1 000 MHz were made with an instrument using peak/average detector mode.

Remark

- “*” means the restricted band.
- Radiated emissions measured in frequency above 1 000 MHz were made with an instrument using Peak/average detector mode if frequency was in restricted band. Otherwise the frequency was in outside of restricted band, only peak detector should be used.
- Average test would be performed if the peak result were greater than the average limit and frequency was in the restricted band.
- To get a maximum emission level from the EUT, the EUT was moved throughout the x-axis, Y-axis and Z-axis. The worst case is Y -axis.
- Actual = Reading + AF + AMP + CL (AF : Antenna factor, AMP : Amp gain, CL : Cable loss)
- Distance factor = $20\log(\text{Measurement distance} / \text{The measured distance})$
- Margin = Limit (dBuV/m) - Actual (dBuV/m)
- If frequency was outside of restricted band, the calculation method for peak limit is same as below: $68.23 \text{ dBuV/m} = \text{EIRP} - 20 \log(d) + 104.77 = -27 - 20 \log(3) + 104.77$
 *distance: 3 m, *EIRP: -27 dBm/MHz

5.1.3. Radiated Restricted Band Edge Measurements

Measurement method : Radiated Conducted
 Mode of operation : Continuous Wave

Table 10. Measurement for restricted band of 11a – Non DFS

Radiated emissions			Ant	Correction factors			Total	Limit	
Frequency (MHz)	Reading (dBuV)	Detect Mode	Pol.	Distance (dB)	AF (dB/m)	Cable loss (dB)	Actual (dBuV/m)	Limit (dBuV/m)	Margin (dB)
5048.20	17.93	Peak	V	-9.54	33.31	8.96	50.66	74.00	23.34
5134.80	12.40	Average	V	-9.54	33.38	9.20	45.44	54.00	8.56
4700.40	17.92	Peak	H	-9.54	32.53	8.85	49.76	74.00	24.24
5119.70	12.95	Average	H	-9.54	33.29	9.34	46.04	54.00	7.96

Table 11. Measurement for restricted band of 11n – Non DFS(5 GHz)

Radiated emissions			Ant	Correction factors			Total	Limit	
Frequency (MHz)	Reading (dBuV)	Detect Mode	Pol.	Distance (dB)	AF (dB/m)	Cable loss (dB)	Actual (dBuV/m)	Limit (dBuV/m)	Margin (dB)
4921.40	17.80	Peak	V	-9.54	33.08	9.40	50.74	74.00	23.26
5119.70	12.54	Average	V	-9.54	33.29	9.34	45.63	54.00	8.37
4875.90	17.33	Peak	H	-9.54	32.81	9.31	49.91	74.00	24.09
4702.60	13.23	Average	H	-9.54	32.56	8.88	45.13	54.00	8.87

Table 12. Measurement for restricted band of 11n(HT20) – Non DFS(5 GHz)

Radiated emissions			Ant	Correction factors			Total	Limit	
Frequency (MHz)	Reading (dBuV)	Detect Mode	Pol.	Distance (dB)	AF (dB/m)	Cable loss (dB)	Actual (dBuV/m)	Limit (dBuV/m)	Margin (dB)
4849.90	18.18	Peak	V	-9.54	32.60	9.18	50.42	74.00	23.58
5147.80	13.54	Average	V	-9.54	33.43	9.08	46.51	54.00	7.49
4770.80	17.17	Peak	H	-9.54	32.33	8.96	48.92	74.00	25.08
4947.40	12.03	Average	H	-9.54	33.27	9.40	45.16	54.00	8.84

Remark

- 1) Radiated emissions measured in frequency above 1 000 MHz were made with an instrument using Peak/average detector mode if frequency was in restricted band. Otherwise the frequency was in outside of restricted band, only peak detector should be used.
- 2) Average test would be performed if the peak result were greater than the average limit and frequency was in the restricted band.
- 3) To get a maximum emission level from the EUT, the EUT was moved throughout the x-axis, Y-axis and Z-axis. The worst case is Y -axis.
- 4) Actual = Reading + AF + AMP + CL (AF : Antenna factor, AMP : Amp gain, CL : Cable loss)
- 5) Distance factor = $20\log(\text{Measurement distance} / \text{The measured distance})$
- 6) Margin = Limit (dBuV/m) - Actual (dBuV/m)
- 7) If frequency was outside of restricted band, the calculation method for peak limit is same as below: $68.23 \text{ dBuV/m} = \text{EIRP} - 20 \log(d) + 104.77 = -27 - 20 \log(3) + 104.77$
 *distance: 3 m, *EIRP: -27 dBm/MHz