

FCC RADIO TEST REPORT

according to

47 CFR FCC Part 15 Subpart C § 15.247

Equipment : 11n draft Wireless LAN Mini-PCI
Model No. : WMIR215GN V2
Brand Name : Sparklan
Filing Type : New Application
Applicant : SparkLAN Communications, Inc.
8F., No.257, Sec. 2, Tiding Blvd., Neihu District, Taipei City
11493, Taiwan.
FCC ID : RYK-WMIR215GNV2
Manufacturer : SparkLAN Communications, Inc.
8F., No.257, Sec. 2, Tiding Blvd., Neihu District, Taipei City
11493, Taiwan.
Received Date : May 14, 2007
Final Test Date : May 30, 2007

Statement

Test result included is only for the 802.11n part of the product.

The test result in this report refers exclusively to the presented test model / sample.

Without written approval of SPORTON International Inc., the test report shall not be reproduced except in full.

The measurements and test results shown in this test report were made in accordance with the procedures and found in compliance with the limit given in **ANSI C63.4-2003** and **47 CFR FCC Part 15 Subpart C**.

The test equipment used to perform the test is calibrated and traceable to NML/ROC.



Testing Laboratory
1190
ILAC MRA

SPORTON International Inc.

6F, No. 106, Sec. 1, Hsin Tai Wu Rd., Hsi Chih, Taipei Hsien, Taiwan, R.O.C.

Table of Contents

1 SUMMARY OF THE TEST RESULT 2

2 GENERAL INFORMATION..... 3

2.1 Product Details 3

2.2 Table for Filed Antenna 3

2.3 Table for Carrier Frequencies 4

2.4 Table for Test Modes 5

2.5 Table for Testing Locations 5

2.6 Table for Supporting Units..... 5

2.7 Table for Parameters of Test Software Setting 6

2.8 EUT Operation during Test 6

2.9 Test Configurations 7

3 TEST RESULT 9

3.1 AC Power Line Conducted Emissions Measurement..... 9

3.2 Maximum Peak Output Power Measurement..... 13

3.3 Power Spectral Density Measurement 15

3.4 6dB Spectrum Bandwidth Measurement..... 20

3.5 Radiated Emissions Measurement..... 25

3.6 Band Edge Emissions Measurement 43

3.7 Antenna Requirements..... 48

4 LIST OF MEASURING EQUIPMENTS 49

5 TEST LOCATION..... 50

6 TAF CERTIFICATE OF ACCREDITATION 51

APPENDIX A. MAXIMUM PERMISSIBLE EXPOSURE..... A1 ~ A3

APPENDIX B. TEST PHOTOS B1 ~ B7

APPENDIX C. PHOTOGRAPHS OF EUT C1 ~ C5

CERTIFICATE OF COMPLIANCE

according to

47 CFR FCC Part 15 Subpart C § 15.247

Equipment : 11n draft Wireless LAN Mini-PCI

Model No. : WMIR215GN V2

Brand Name : Sparklan

Applicant : SparkLAN Communications, Inc.

8F., No.257, Sec. 2, Tiding Blvd., Neihs District,
Taipei City 11493, Taiwan.

Sporton International as requested by the applicant to evaluate the EMC performance of the product sample received on May 14, 2007 would like to declare that the tested sample has been evaluated and found to be in compliance with the tested rule parts. The data recorded as well as the test configuration specified is true and accurate for showing the sample's EMC nature.



Wayne Hsu

SPORTON International Inc.

6F, No.106, Sec. 1, Hsin Tai Wu Rd., Hsi Chih, Taipei Hsien, Taiwan, R.O.C.

1 SUMMARY OF THE TEST RESULT

| Applied Standard: 47 CFR FCC Part 15 Subpart C | | | | |
|--|--------------|-------------------------------------|----------|-------------|
| Part | Rule Section | Description of Test | Result | Under Limit |
| 3.1 | 15.207 | AC Power Line Conducted Emissions | Complies | 13.05 dB |
| 3.2 | 15.247(b)(3) | Maximum Peak Conducted Output Power | Complies | 9.39 dB |
| 3.3 | 15.247(e) | Power Spectral Density | Complies | 22.68 dB |
| 3.4 | 15.247(a)(2) | 6dB Spectrum Bandwidth | Complies | - |
| 3.5 | 15.247(d) | Radiated Emissions | Complies | 1.70 dB |
| 3.6 | 15.247(d) | Band Edge Emissions | Complies | 1.47 dB |
| 3.7 | 15.203 | Antenna Requirements | Complies | - |

| Test Items | Uncertainty | Remark |
|---|-----------------------|--------------------------|
| AC Power Line Conducted Emissions | ±2.3dB | Confidence levels of 95% |
| Maximum Peak Conducted Output Power | ±0.8dB | Confidence levels of 95% |
| Power Spectral Density | ±0.5dB | Confidence levels of 95% |
| 6dB Spectrum Bandwidth | ±8.5×10 ⁻⁸ | Confidence levels of 95% |
| Radiated Emissions (9kHz~30MHz) | ±0.8dB | Confidence levels of 95% |
| Radiated Emissions (30MHz~1000MHz) | ±1.9dB | Confidence levels of 95% |
| Radiated / Band Edge Emissions (1GHz~18GHz) | ±1.9dB | Confidence levels of 95% |
| Radiated Emissions (18GHz~40GHz) | ±1.9dB | Confidence levels of 95% |
| Temperature | ±0.7 | Confidence levels of 95% |
| Humidity | ±3.2% | Confidence levels of 95% |
| DC / AC Power Source | ±1.4% | Confidence levels of 95% |

2 GENERAL INFORMATION

2.1 Product Details

| Items | Description |
|--------------------------|---|
| Power Type | Power from host |
| Modulation | OFDM |
| Data Modulation | OFDM (BPSK / QPSK / 16QAM / 64QAM) |
| Data Rate (Mbps) | OFDM (6/9/12/18/24/36/48/54) |
| Frequency Range | 2400 ~ 2483.5MHz |
| Channel Number | 11 for 20MHz bandwidth ; 7 for 40MHz bandwidth |
| Channel Band Width (99%) | MCS15 (20MHz) : 17.64 MHz ; MCS15 (40MHz) : 36.10 MHz |
| Conducted Output Power | MCS15 (20MHz): 20.61 dBm ; MCS15 (40MHz): 18.31 dBm |

2.2 Table for Filed Antenna

Antenna & Bandwidth

| Antenna | Single (Tx) | | Two (Tx) | |
|---------|-------------|--------|----------|--------|
| | 20 MHz | 40 MHz | 20 MHz | 40 MHz |
| 802.11b | V | X | X | X |
| 802.11g | V | X | X | X |
| 802.11n | X | X | V | V |

| Ant. | Antenna Type | Connector | Gain (dBi) |
|------|--------------|-----------|------------|
| 1 | Dipole | UFL | 3dBi |
| 2 | Dipole | UFL | 3dBi |
| 3 | Dipole | UFL | 3dBi |

Antenna: Internal 3 Antennas with Two TX and Three RX.

IEEE 802.11n Modulation Scheme

| MCS Index | Nss | Modulation | R | NBPSC | NCBPS | | NDBPS | | Data rate(Mbps) | |
|-----------|-----|------------|-----|-------|-------|-------|-------|-------|-----------------|-------|
| | | | | | 20MHz | 40MHz | 20MHz | 40MHz | 800nsGI | |
| | | | | | | | | | 20MHz | 40MHz |
| 0 | 1 | BPSK | 1/2 | 1 | 52 | 108 | 26 | 54 | 6.5 | 13.5 |
| 1 | 1 | QPSK | 1/2 | 2 | 104 | 216 | 52 | 108 | 13.0 | 27.0 |
| 2 | 1 | QPSK | 3/4 | 2 | 104 | 216 | 78 | 162 | 19.5 | 40.5 |
| 3 | 1 | 16-QAM | 1/2 | 4 | 208 | 432 | 104 | 216 | 26.0 | 54.0 |
| 4 | 1 | 16-QAM | 3/4 | 4 | 208 | 432 | 156 | 324 | 39.0 | 81.0 |
| 5 | 1 | 64-QAM | 2/3 | 6 | 312 | 648 | 208 | 432 | 52.0 | 108.0 |
| 6 | 1 | 64-QAM | 3/4 | 6 | 312 | 648 | 234 | 486 | 58.5 | 121.5 |
| 7 | 1 | 64-QAM | 5/6 | 6 | 312 | 648 | 260 | 540 | 65.0 | 135.0 |
| 8 | 2 | BPSK | 1/2 | 1 | 104 | 216 | 52 | 108 | 13.0 | 27.0 |
| 9 | 2 | QPSK | 1/2 | 2 | 208 | 432 | 104 | 216 | 26.0 | 54.0 |
| 10 | 2 | QPSK | 3/4 | 2 | 208 | 432 | 156 | 324 | 39.0 | 81.0 |
| 11 | 2 | 16-QAM | 1/2 | 4 | 416 | 864 | 208 | 432 | 52.0 | 108.0 |
| 12 | 2 | 16-QAM | 3/4 | 4 | 416 | 864 | 312 | 648 | 78.0 | 162.0 |
| 13 | 2 | 64-QAM | 2/3 | 6 | 624 | 1296 | 416 | 864 | 104.0 | 216.0 |
| 14 | 2 | 64-QAM | 3/4 | 6 | 624 | 1296 | 468 | 972 | 117.0 | 243.0 |
| 15 | 2 | 64-QAM | 5/6 | 6 | 624 | 1296 | 520 | 1080 | 130.0 | 270.0 |

| Symbol | Explanation |
|--------|---|
| NSS | Number of spatial streams |
| R | Code rate |
| NBPSC | Number of coded bits per single carrier |
| NCBPS | Number of coded bits per symbol |
| NDBPS | Number of data bits per symbol |
| GI | guard interval |

2.3 Table for Carrier Frequencies

There are two bandwidth systems for draft 802.11n.

For both 20MHz bandwidth systems, use Channel 1~Channel 11.

For both 40MHz bandwidth systems, use Channel 3~Channel 9.

| Frequency Band | Channel No. | Frequency | Channel No. | Frequency |
|----------------|-------------|-----------|-------------|-----------|
| 2400~2483.5MHz | 1 | 2412 MHz | 7 | 2442 MHz |
| | 2 | 2417 MHz | 8 | 2447 MHz |
| | 3 | 2422 MHz | 9 | 2452 MHz |
| | 4 | 2427 MHz | 10 | 2457 MHz |
| | 5 | 2432 MHz | 11 | 2462 MHz |
| | 6 | 2437 MHz | | |

2.4 Table for Test Modes

Preliminary tests were performed in different data rate to find the worst radiated emission. The data rate shown in the table below is the worst-case rate with respect to the specific test item. Investigation has been done on all the possible configurations for searching the worst cases. The following table is a list of the test modes shown in this test report. This product is an extension of original one reported under Sporton project number: FR740303-n.

| Test Items | Mode | Channel | Antenna |
|---|---------------|---------|---------|
| AC Power Line Conducted Emissions | Receiver Mode | - | - |
| Maximum Peak Conducted Output Power | MCS15 (20MHz) | 1/6/11 | 1+2 |
| Power Spectral Density | MCS15 (40MHz) | 3/6/9 | 1+2 |
| 6dB Spectrum Bandwidth | | | |
| Radiated Emissions 9kHz~1GHz | MCS15 (40MHz) | 6 | 1+2 |
| Radiated Emissions 1GHz~10 th Harmonic | MCS15 (20MHz) | 1/6/11 | 1+2 |
| | MCS15 (40MHz) | 3/6/9 | 1+2 |
| Band Edge Emissions | MCS15 (20MHz) | 1/6/11 | 1+2 |
| | MCS15 (40MHz) | 3/6/9 | 1+2 |

2.5 Table for Testing Locations

| Test Site No. | Site Category | Location | FCC Reg. No. | IC File No. | VCCI Reg. No |
|---------------|---------------|----------|--------------|-------------|--------------|
| 03CH03-HY | SAC | Hwa Ya | 101377 | IC 4086B-1 | - |
| CO04-HY | Conduction | Hwa Ya | 101377 | IC 4086B-1 | - |
| TH01-HY | OVEN Room | Hwa Ya | - | - | - |

Open Area Test Site (OATS); Semi Anechoic Chamber (SAC); Fully Anechoic Chamber (FAC).

2.6 Table for Supporting Units

| Support Unit | Brand | Model | FCC ID |
|--------------|-----------|--------|------------|
| USB Mouse | Microsoft | 1004 | DoC |
| Notebook | DELL | D400 | DoC |
| Modem | ACEEX | DM1414 | IFAXDM1414 |

2.7 Table for Parameters of Test Software Setting

During testing, Channel & Power Controlling Software provided by the customer was used to control the operating channel as well as the output power level. The RF output power selection is for the setting of RF output power expected by the customer and is going to be fixed on the firmware of the final end product.

Power Parameters of IEEE 802.11n (20MHz)

| Test Software Version | Ralink Test for Sor RT 2860 | | |
|-----------------------|-----------------------------|----------|----------|
| Frequency | 2412 MHz | 2437 MHz | 2462 MHz |
| IEEE 802.11n | 08 06 | 0C 0A | 0F 0B |

Power Parameters of IEEE 802.11n (40MHz)

| Test Software Version | Ralink Test for Sor RT 2860 | | |
|-----------------------|-----------------------------|----------|----------|
| Frequency | 2422 MHz | 2437 MHz | 2452 MHz |
| IEEE 802.11n | 12 05 | 0C 0A | 0E 0B |

2.8 EUT Operation during Test

An executive program, EMCTEST.EXE under WIN XP, which generates a complete line of continuously repeating “ H “ pattern was used as the test software.

The program was executed as follows:

Turn on the power of all equipment.

The NB sends “ H “ messages to the panel, and the panel displays “ H “ patterns on the screen.

The NB sends “ H “ messages to the modem.

2.9 Test Configurations

2.9.1 Radiation Emissions Test Configuration

For radiated emissions above 30MHz

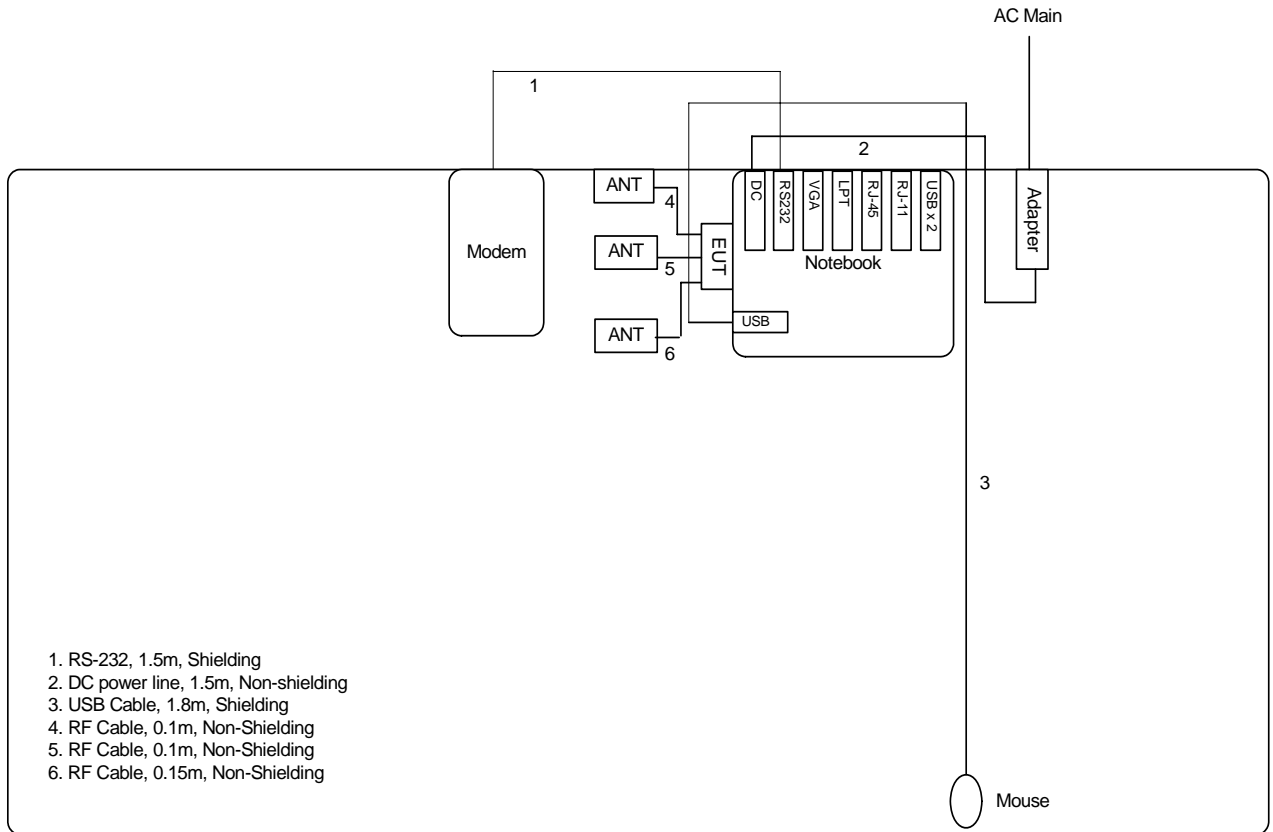

For radiated emissions above 1GHz

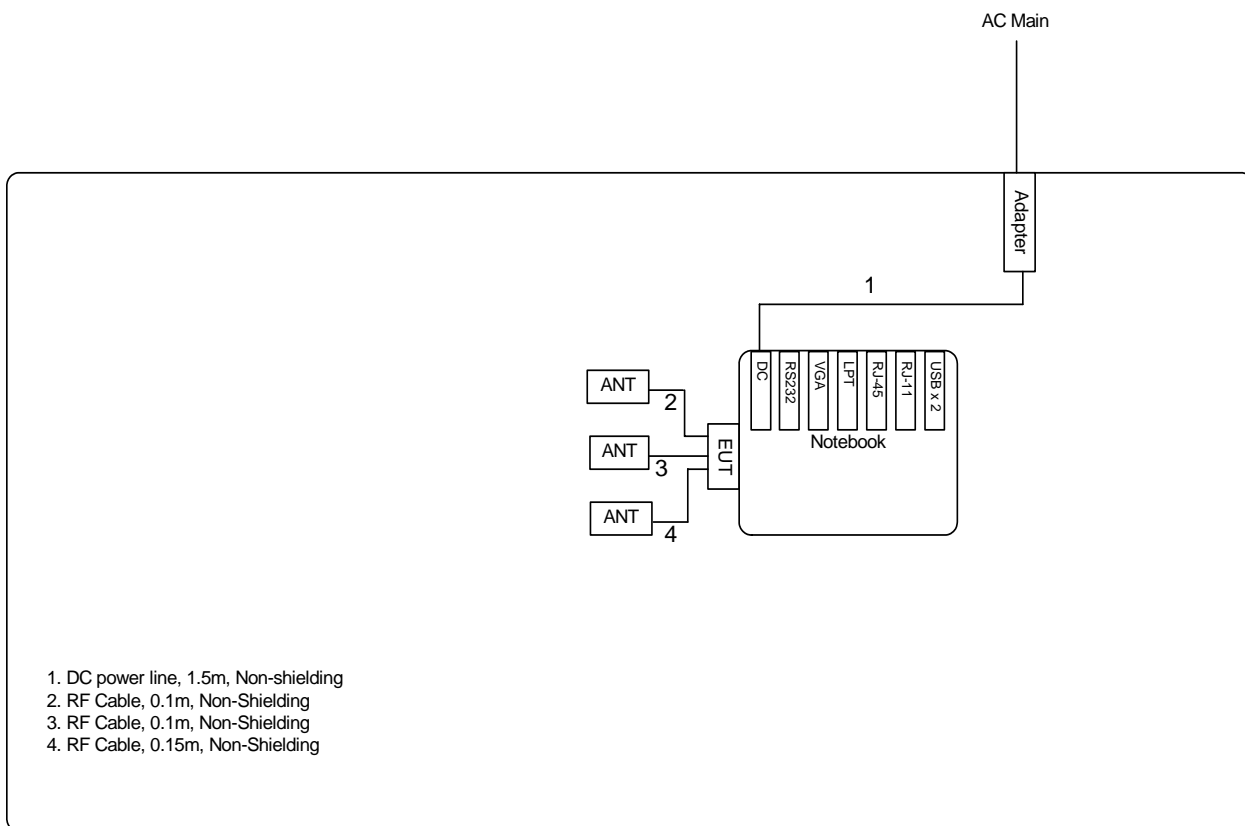

3 TEST RESULT

3.1 AC Power Line Conducted Emissions Measurement

3.1.1 Limit

For this product which is designed to be connected to the AC power line, the radio frequency voltage that is conducted back onto the AC power line on any frequency or frequencies within the band 150 kHz to 30 MHz shall not exceed below limits table.

| Frequency (MHz) | QP Limit (dBuV) | AV Limit (dBuV) |
|-----------------|-----------------|-----------------|
| 0.15~0.5 | 66~56 | 56~46 |
| 0.5~5 | 56 | 46 |
| 5~30 | 60 | 50 |

3.1.2 Measuring Instruments and Setting

Please refer to section 4 of equipments list in this report. The following table is the setting of the receiver.

| Receiver Parameters | Setting |
|---------------------|----------|
| Attenuation | 10 dB |
| Start Frequency | 0.15 MHz |
| Stop Frequency | 30 MHz |
| IF Bandwidth | 9 KHz |

3.1.3 Test Procedures

1. Configure the EUT according to ANSI C63.4. The EUT or host of EUT has to be placed 0.4 meter far from the conducting wall of the shielding room and at least 80 centimeters from any other grounded conducting surface.
2. Connect EUT or host of EUT to the power mains through a line impedance stabilization network (LISN).
3. All the support units are connected to the other LISNs. The LISN should provide 50uH/50ohms coupling impedance.
4. The frequency range from 150 KHz to 30 MHz was searched.
5. Set the test-receiver system to Peak Detect Function and Specified Bandwidth with Maximum Hold Mode.
6. The measurement has to be done between each power line and ground at the power terminal.

3.1.4 Test Setup Layout

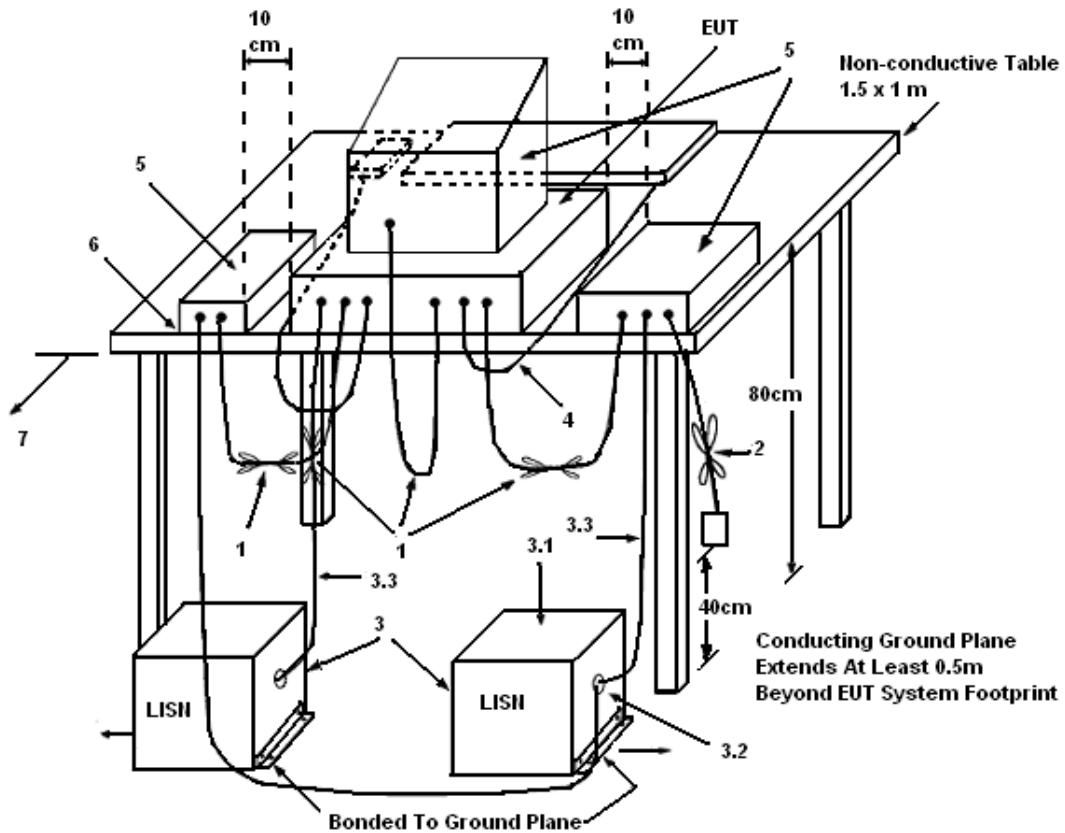

LEGEND:

- (1) Interconnecting cables that hang closer than 40 cm to the ground plane shall be folded back and forth in the center forming a bundle 30 to 40 cm long.
- (2) I/O cables that are not connected to a peripheral shall be bundled in the center. The end of the cable may be terminated, if required, using the correct terminating impedance. The overall length shall not exceed 1 m.
- (3) EUT connected to one LISN. Unused LISN measuring port connectors shall be terminated in 50 Ω. LISN can be placed on top of, or immediately beneath, reference ground plane.
 - (3.1) All other equipment powered from additional LISN(s).
 - (3.2) Multiple outlet strip can be used for multiple power cords of non-EUT equipment.
 - (3.3) LISN at least 80 cm from nearest part of EUT chassis.
- (4) Cables of hand-operated devices, such as keyboards, mice, etc., shall be placed as for normal use.
- (5) Non-EUT components of EUT system being tested.
- (6) Rear of EUT, including peripherals, shall all be aligned and flush with rear of tabletop.
- (7) Rear of tabletop shall be 40 cm removed from a vertical conducting plane that is bonded to the ground plane.

3.1.5 Test Deviation

There is no deviation with the original standard.

3.1.6 EUT Operation during Test

The EUT was placed on the test table and programmed in normal function.

3.1.7 Results of AC Power Line Conducted Emissions Measurement

| | | | |
|---------------|---------------|----------|------|
| Temperature | 27 | Humidity | 49 % |
| Test Engineer | Ted | Phase | Line |
| Configuration | Receiver Mode | | |

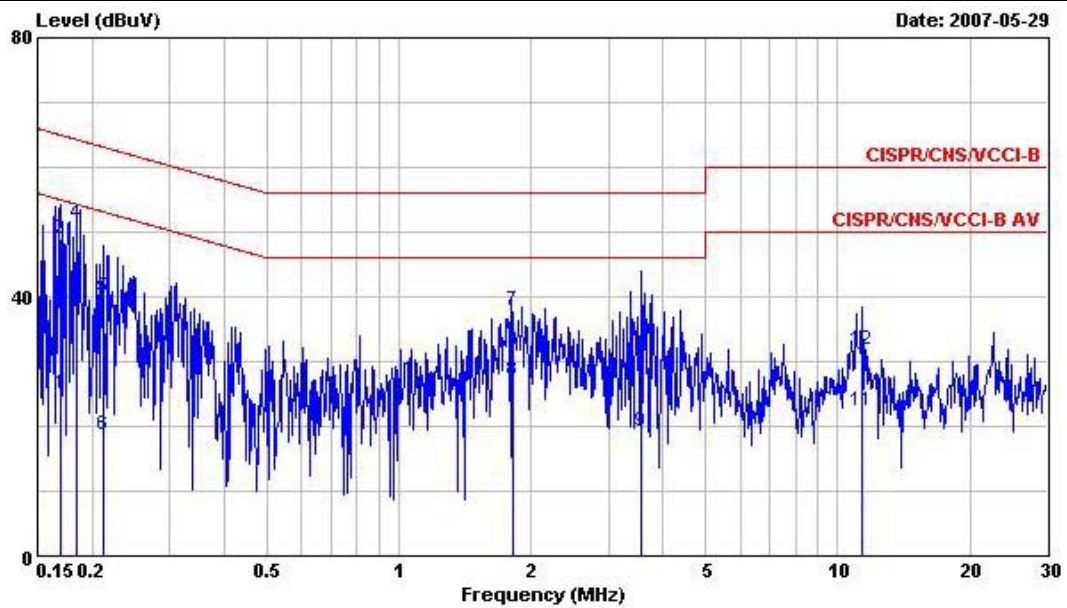

| | Freq | Level | Over | Limit | Read | LISN | Cable | Remark | Preamp |
|----|-----------|-------|--------|-------|-------|--------|-------|---------|--------|
| | MHz | dBuV | Limit | Line | Level | Factor | Loss | | Factor |
| | | | dB | dBuV | dBuV | dB | dB | | dB |
| 1 | 0.1694400 | 25.07 | -29.92 | 54.99 | 24.83 | 0.10 | 0.14 | Average | 0.00 |
| 2 | 0.1694400 | 49.06 | -15.93 | 64.99 | 48.82 | 0.10 | 0.14 | QP | 0.00 |
| 3 | 0.1839400 | 39.04 | -15.27 | 54.31 | 38.80 | 0.10 | 0.14 | Average | 0.00 |
| 4 | 0.1839400 | 51.26 | -13.05 | 64.31 | 51.02 | 0.10 | 0.14 | QP | 0.00 |
| 5 | 0.2116700 | 39.88 | -23.26 | 63.14 | 39.59 | 0.10 | 0.19 | QP | 0.00 |
| 6 | 0.2116700 | 18.76 | -34.38 | 53.14 | 18.47 | 0.10 | 0.19 | Average | 0.00 |
| 7 | 1.810 | 37.87 | -18.13 | 56.00 | 37.34 | 0.10 | 0.43 | QP | 0.00 |
| 8 | 1.810 | 27.11 | -18.89 | 46.00 | 26.58 | 0.10 | 0.43 | Average | 0.00 |
| 9 | 3.570 | 19.15 | -26.85 | 46.00 | 18.71 | 0.10 | 0.34 | Average | 0.00 |
| 10 | 3.570 | 33.24 | -22.76 | 56.00 | 32.80 | 0.10 | 0.34 | QP | 0.00 |
| 11 | 11.312 | 22.25 | -27.75 | 50.00 | 21.73 | 0.32 | 0.20 | Average | 0.00 |
| 12 | 11.312 | 31.93 | -28.07 | 60.00 | 31.41 | 0.32 | 0.20 | QP | 0.00 |

| | | | |
|---------------|---------------|----------|---------|
| Temperature | 27 | Humidity | 49 % |
| Test Engineer | Ted | Phase | Neutral |
| Configuration | Receiver Mode | | |

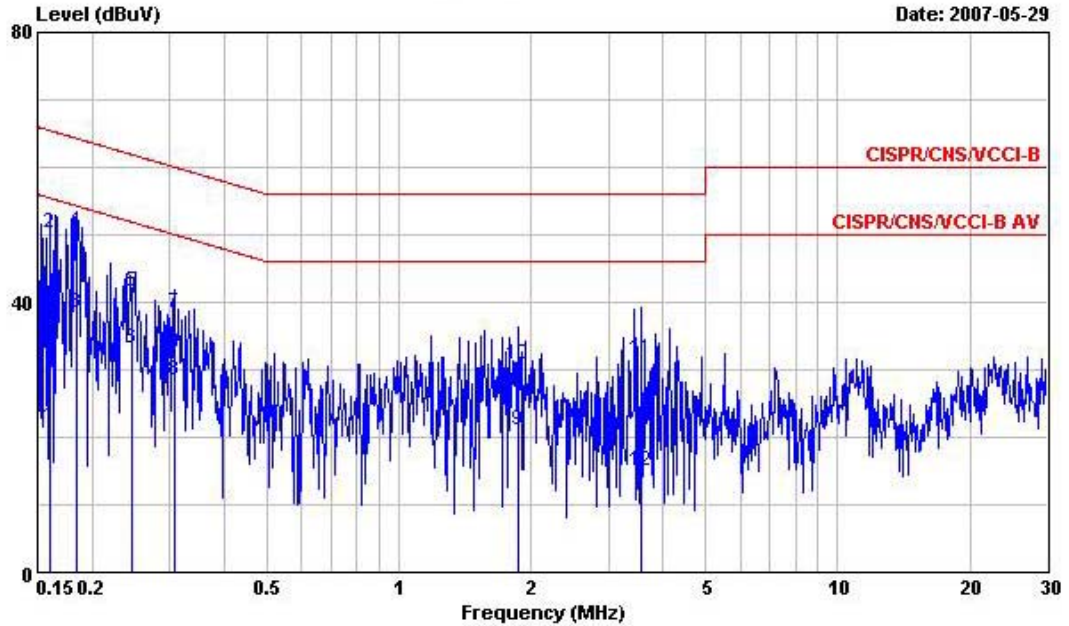

| | Freq | Level | Over Limit | Limit Line | Read Level | LISN Factor | Cable Loss | Remark | Preamp Factor |
|----|-----------|-------|------------|------------|------------|-------------|------------|---------|---------------|
| | MHz | dBuV | dB | dBuV | dBuV | dB | dB | | dB |
| 1 | 0.1598470 | 21.68 | -33.79 | 55.47 | 21.44 | 0.10 | 0.14 | Average | 0.00 |
| 2 | 0.1598470 | 50.37 | -15.10 | 65.47 | 50.13 | 0.10 | 0.14 | QP | 0.00 |
| 3 | 0.1850360 | 38.50 | -15.76 | 54.26 | 38.26 | 0.10 | 0.14 | Average | 0.00 |
| 4 | 0.1850360 | 50.51 | -13.75 | 64.26 | 50.27 | 0.10 | 0.14 | QP | 0.00 |
| 5 | 0.2459790 | 41.55 | -20.34 | 61.89 | 41.13 | 0.10 | 0.32 | QP | 0.00 |
| 6 | 0.2459790 | 33.19 | -18.70 | 51.89 | 32.77 | 0.10 | 0.32 | Average | 0.00 |
| 7 | 0.3067120 | 38.54 | -21.52 | 60.06 | 37.94 | 0.10 | 0.50 | QP | 0.00 |
| 8 | 0.3067120 | 28.43 | -21.63 | 50.06 | 27.83 | 0.10 | 0.50 | Average | 0.00 |
| 9 | 1.876 | 20.95 | -25.05 | 46.00 | 20.42 | 0.10 | 0.43 | Average | 0.00 |
| 10 | 1.876 | 30.87 | -25.13 | 56.00 | 30.34 | 0.10 | 0.43 | QP | 0.00 |
| 11 | 3.570 | 31.54 | -24.46 | 56.00 | 31.02 | 0.18 | 0.34 | QP | 0.00 |
| 12 | 3.570 | 15.05 | -30.95 | 46.00 | 14.53 | 0.18 | 0.34 | Average | 0.00 |

Note:

Level = Read Level + LISN Factor + Cable Loss.

3.2 Maximum Peak Output Power Measurement

3.2.1 Limit

For systems using digital modulation in the 2400-2483.5MHz, the limit for peak output power is 30dBm. The limited has to be reduced by the amount in dB that the gain of the antenna exceed 6dBi. In case of point-to-point operation, the limit has to be reduced by 1dB for every 3dB that the directional gain of the antenna exceeds 6dBi.

3.2.2 Measuring Instruments and Setting

Please refer to section 4 of equipments list in this report. The following table is the setting of the power meter.

| Power Meter Parameter | Setting |
|-----------------------|--------------------|
| Filter No. | Auto |
| Measurement time | 0.135 s ~ 26 s |
| Used Peak Sensor | NRV-Z32 (model 04) |

3.2.3 Test Procedures

1. The transmitter output (antenna port) was connected to the power meter.
2. Turn on the EUT and power meter and then record the peak power value.
3. Repeat above procedures on all channels needed to be tested.

3.2.4 Test Setup Layout

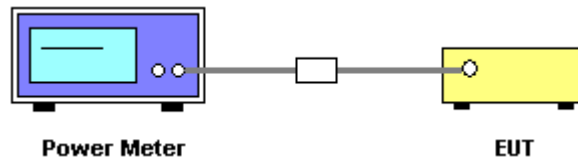

3.2.5 Test Deviation

There is no deviation with the original standard.

3.2.6 EUT Operation during Test

The EUT was programmed to be in continuously transmitting mode.

3.2.7 Test Result of Maximum Peak Output Power

| | | | |
|----------------------|--------|-----------------------|---------|
| Temperature | 28 | Humidity | 58 % |
| Test Engineer | Murphy | Configurations | 802.11n |

Configuration IEEE 802.11n (20MHz)

| Channel | Frequency | Ant. 1 Power (dBm) | Ant. 2 Power (dBm) | Ant. 1+Ant. 2 Power (dBm) | Max. Limit (dBm) | Result |
|---------|-----------|--------------------|--------------------|---------------------------|------------------|-----------------|
| 1 | 2412 MHz | 15.80 | 16.02 | 18.92 | 30.00 | Complies |
| 6 | 2437 MHz | 17.71 | 17.42 | 20.58 | 30.00 | Complies |
| 11 | 2462 MHz | 17.75 | 17.45 | 20.61 | 30.00 | Complies |

Configuration IEEE 802.11n (40MHz)

| Channel | Frequency | Ant. 1 Power (dBm) | Ant. 2 Power (dBm) | Ant. 1+Ant. 2 Power (dBm) | Max. Limit (dBm) | Result |
|---------|-----------|--------------------|--------------------|---------------------------|------------------|-----------------|
| 3 | 2422 MHz | 15.48 | 15.12 | 18.31 | 30.00 | Complies |
| 6 | 2437 MHz | 15.23 | 14.84 | 18.05 | 30.00 | Complies |
| 9 | 2452 MHz | 15.42 | 15.07 | 18.26 | 30.00 | Complies |

3.3 Power Spectral Density Measurement

3.3.1 Limit

For digitally modulated systems, the power spectral density conducted from the intentional radiator to the antenna shall not be greater than 8 dBm in any 3 kHz band during any time interval of continuous transmission.

3.3.2 Measuring Instruments and Setting

Please refer to section 4 of equipments list in this report. The following table is the setting of Spectrum Analyzer.

| Spectrum Parameter | Setting |
|--------------------|----------|
| Attenuation | Auto |
| Span Frequency | 1.5MHz |
| RB | 3 kHz |
| VB | 30 kHz |
| Detector | Peak |
| Trace | Max Hold |
| Sweep Time | 500s |

3.3.3 Test Procedures

1. The transmitter output (antenna port) was connected to the spectrum analyser.
2. Set RBW of spectrum analyzer to 3kHz and VBW to 30kHz. Set Detector to Peak, Trace to Max Hold.
3. Mark the frequency with maximum peak power as the center of the display of the spectrum.
4. Set the span to 1.5MHz and the sweep time to 500s and record the maximum peak value.

3.3.4 Test Setup Layout

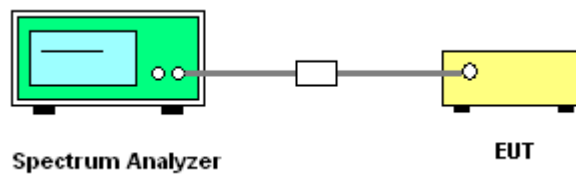

3.3.5 Test Deviation

There is no deviation with the original standard.

3.3.6 EUT Operation during Test

The EUT was programmed to be in continuously transmitting mode.

3.3.7 Test Result of Power Spectral Density

| | | | |
|----------------------|--------|-----------------------|---------|
| Temperature | 28 | Humidity | 58 % |
| Test Engineer | Murphy | Configurations | 802.11n |

Configuration IEEE 802.11n (20MHz)

| Channel | Frequency | Power Density (dBm) | Max. Limit (dBm) | Result |
|---------|-----------|---------------------|------------------|-----------------|
| 1 | 2412 MHz | -16.06 | 8.00 | Complies |
| 6 | 2437 MHz | -14.99 | 8.00 | Complies |
| 11 | 2462 MHz | -14.68 | 8.00 | Complies |

Configuration IEEE 802.11n (40MHz)

| Channel | Frequency | Power Density (dBm) | Max. Limit (dBm) | Result |
|---------|-----------|---------------------|------------------|-----------------|
| 3 | 2422 MHz | -17.61 | 8.00 | Complies |
| 6 | 2437 MHz | -18.36 | 8.00 | Complies |
| 9 | 2452 MHz | -18.14 | 8.00 | Complies |

Power Density Plot on Configuration IEEE 802.11n (20MHz) / 2412 MHz

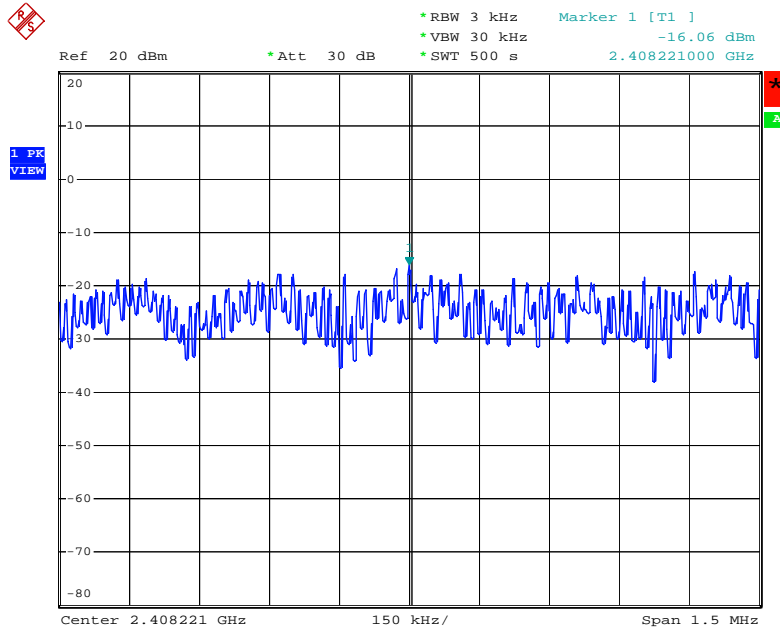

Date: 29.MAY.2007 08:33:18

Power Density Plot on Configuration IEEE 802.11n (20MHz) / 2437 MHz

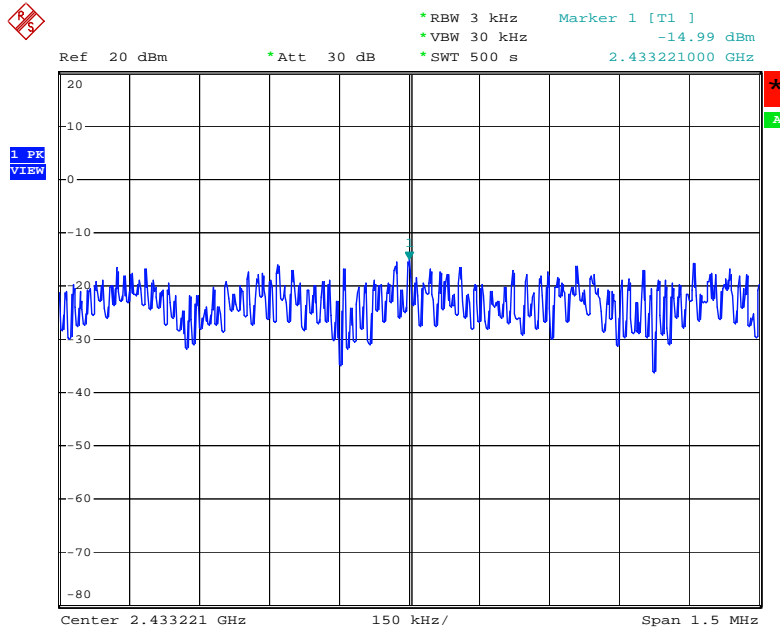

Date: 29.MAY.2007 08:43:07

Power Density Plot on Configuration IEEE 802.11n (20MHz) / 2462 MHz

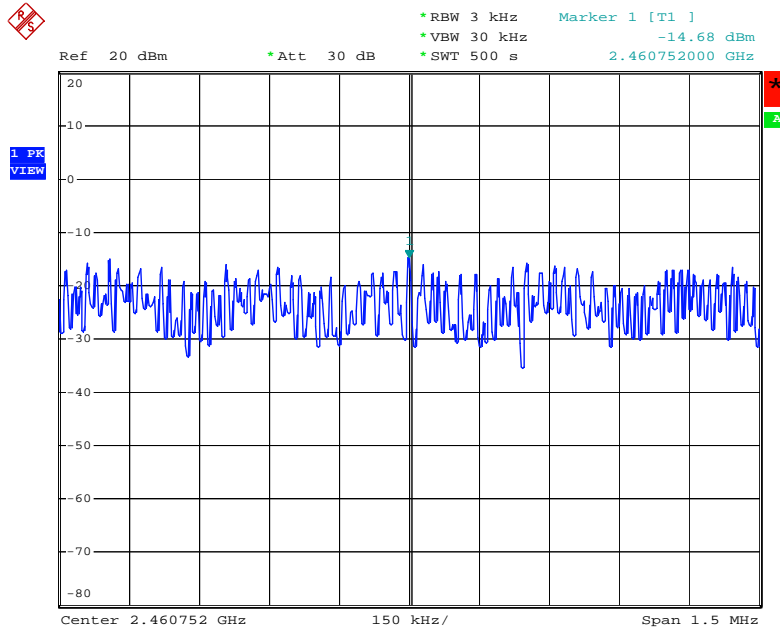

Date: 29.MAY.2007 08:53:46

Power Density Plot on Configuration IEEE 802.11n (40MHz) / 2422 MHz

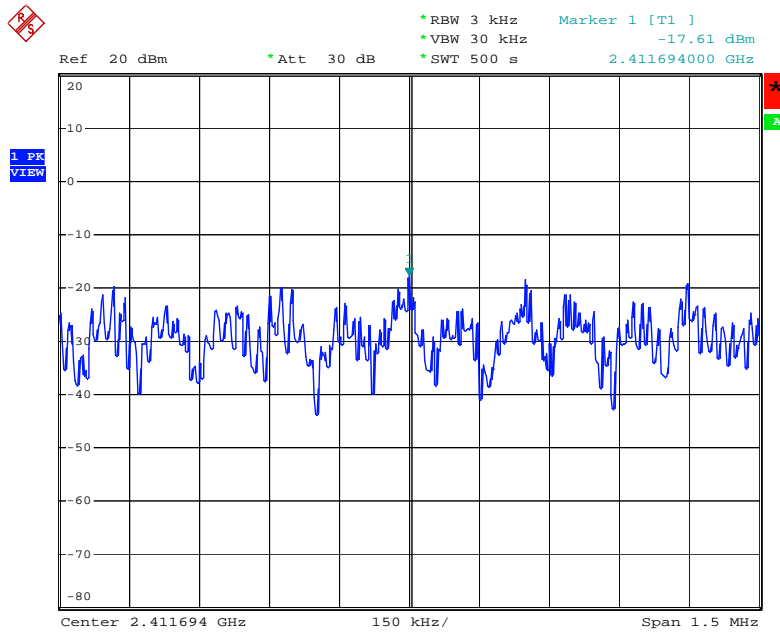

Date: 29.MAY.2007 08:03:20

Power Density Plot on Configuration IEEE 802.11n (40MHz) / 2437 MHz

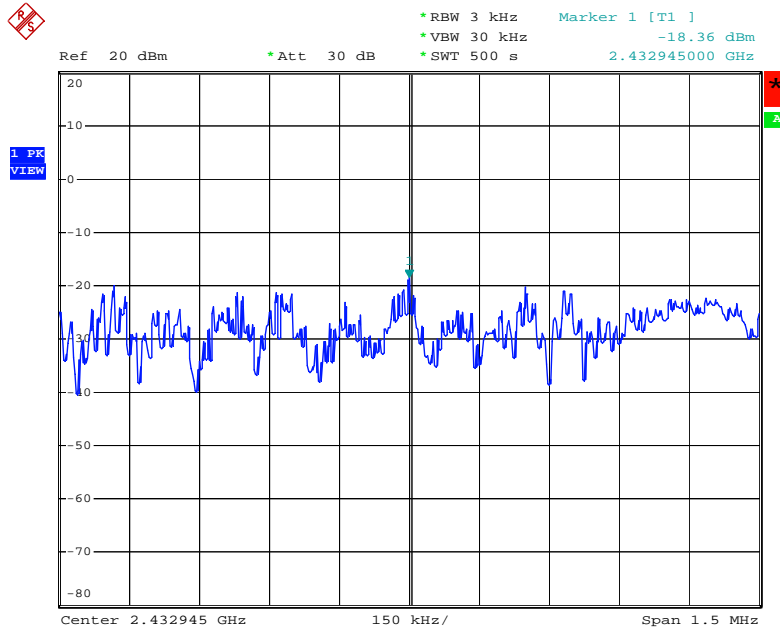

Date: 29.MAY.2007 08:09:24

Power Density Plot on Configuration IEEE 802.11n (40MHz) / 2452 MHz

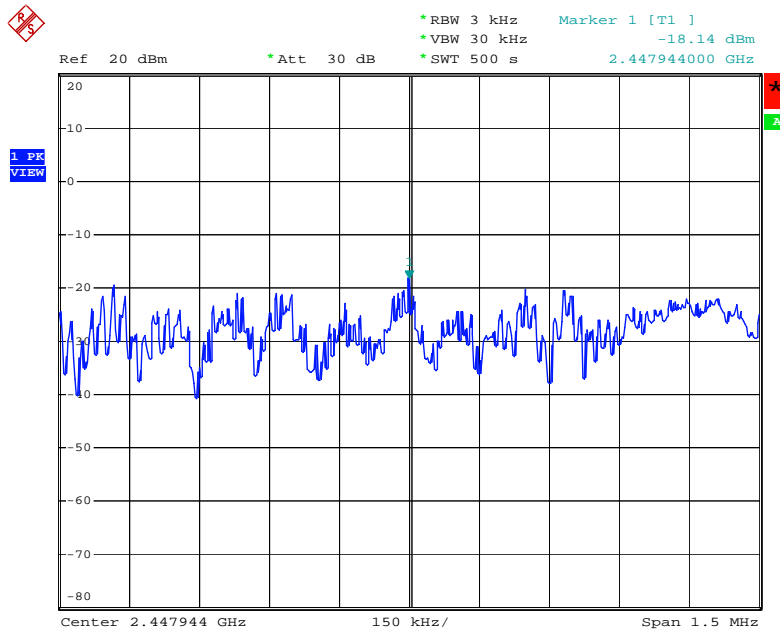

Date: 29.MAY.2007 08:17:24

3.4 6dB Spectrum Bandwidth Measurement

3.4.1 Limit

For digital modulation systems, the minimum 6 dB bandwidth shall be at least 500 kHz.

3.4.2 Measuring Instruments and Setting

Please refer to section 4 of equipments list in this report. The following table is the setting of the Spectrum Analyzer.

| Spectrum Parameters | Setting |
|---------------------|-----------------|
| Attenuation | Auto |
| Span Frequency | > 6dB Bandwidth |
| RB | 100 kHz |
| VB | 100 kHz |
| Detector | Peak |
| Trace | Max Hold |
| Sweep Time | Auto |

3.4.3 Test Procedures

1. The transmitter output (antenna port) was connected to the spectrum analyser in peak hold mode.
2. The resolution bandwidth of 100 kHz and the video bandwidth of 100 kHz were used.
3. Measured the spectrum width with power higher than 6dB below carrier.

3.4.4 Test Setup Layout

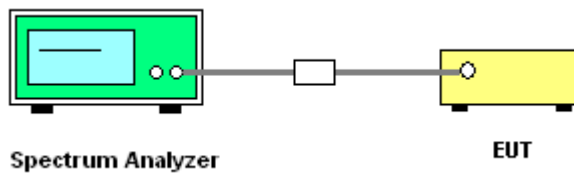

3.4.5 Test Deviation

There is no deviation with the original standard.

3.4.6 EUT Operation during Test

The EUT was programmed to be in continuously transmitting mode.

3.4.7 Test Result of 6dB Spectrum Bandwidth

| | | | |
|----------------------|--------|-----------------------|---------|
| Temperature | 28 | Humidity | 58 % |
| Test Engineer | Murphy | Configurations | 802.11n |

Configuration IEEE 802.11n (20MHz)

| Channel | Frequency | 6dB Bandwidth (MHz) | 99% Occupied Bandwidth (MHz) | Min. Limit (kHz) | Test Result |
|---------|-----------|---------------------|------------------------------|------------------|-----------------|
| 1 | 2412 MHz | 17.76 | 17.64 | 500 | Complies |
| 6 | 2437 MHz | 17.72 | 17.60 | 500 | Complies |
| 11 | 2462 MHz | 17.72 | 17.60 | 500 | Complies |

Configuration IEEE 802.11n (40MHz)

| Channel | Frequency | 6dB Bandwidth (MHz) | 99% Occupied Bandwidth (MHz) | Min. Limit (kHz) | Test Result |
|---------|-----------|---------------------|------------------------------|------------------|-----------------|
| 3 | 2422 MHz | 36.50 | 36.10 | 500 | Complies |
| 6 | 2437 MHz | 36.40 | 36.10 | 500 | Complies |
| 9 | 2452 MHz | 36.40 | 36.10 | 500 | Complies |

6 dB Bandwidth Plot on Configuration IEEE 802.11n (20MHz) / 2412 MHz

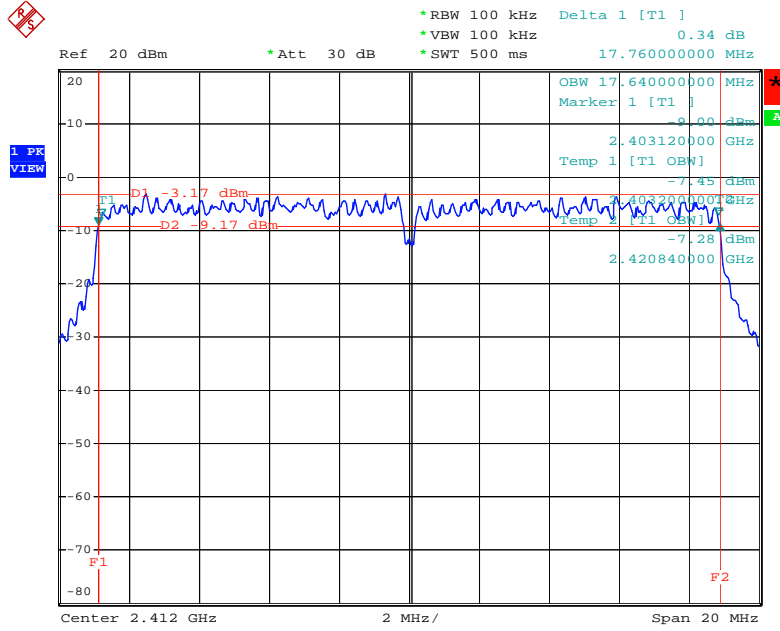

Date: 30.MAY.2007 12:38:32

6 dB Bandwidth Plot on Configuration IEEE 802.11n (20MHz) / 2437 MHz

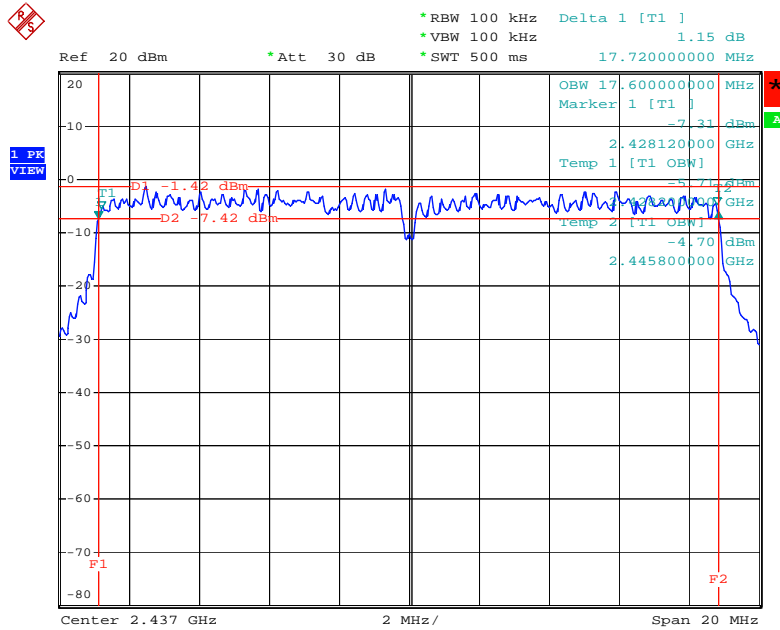

Date: 30.MAY.2007 12:41:19

6 dB Bandwidth Plot on Configuration IEEE 802.11n (20MHz) / 2462 MHz

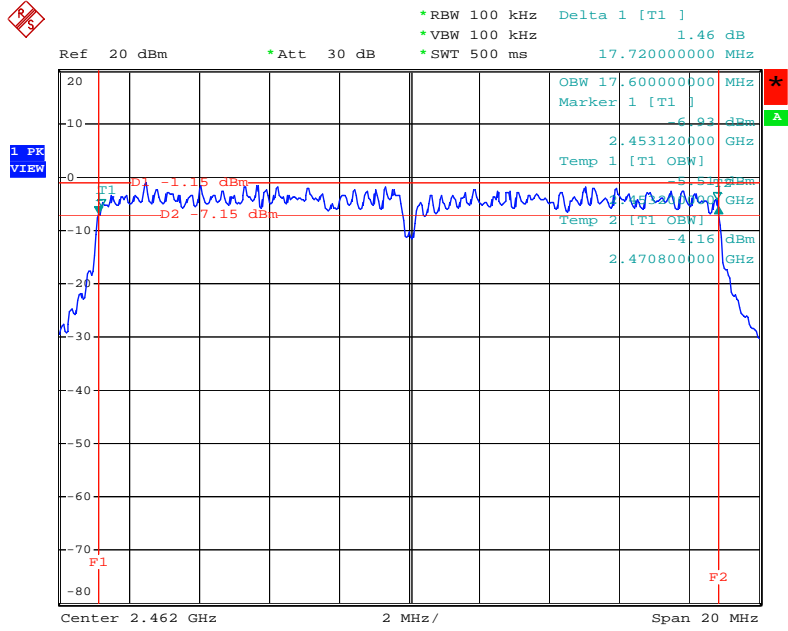

Date: 30.MAY.2007 12:44:16

6 dB Bandwidth Plot on Configuration IEEE 802.11n (40MHz) / 2422 MHz

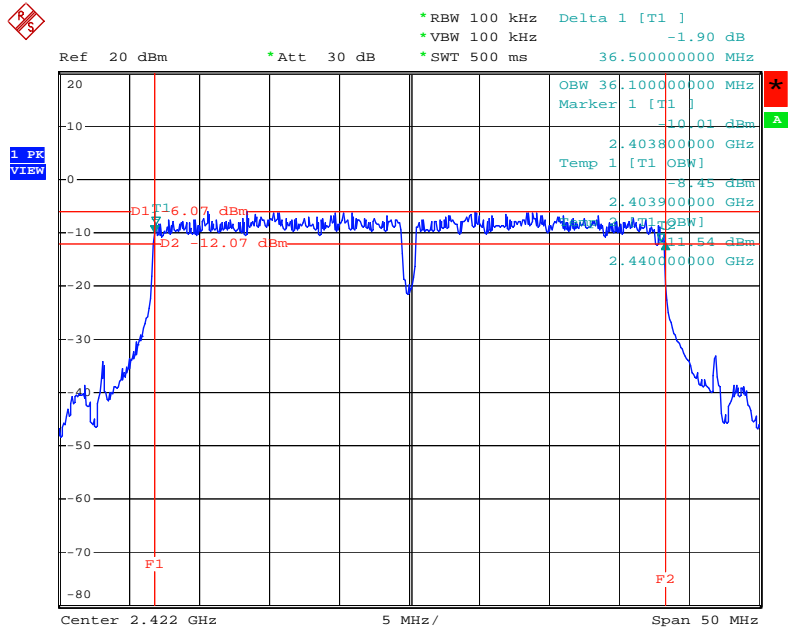

Date: 30.MAY.2007 12:49:04

6 dB Bandwidth Plot on Configuration IEEE 802.11n (40MHz) / 2437 MHz

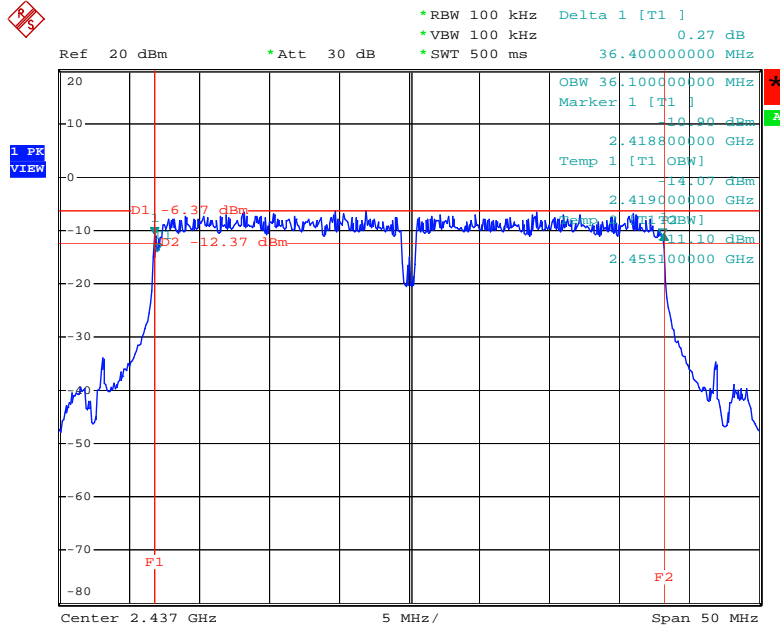

Date: 30.MAY.2007 12:51:26

6 dB Bandwidth Plot on Configuration IEEE 802.11n (40MHz) / 2452 MHz

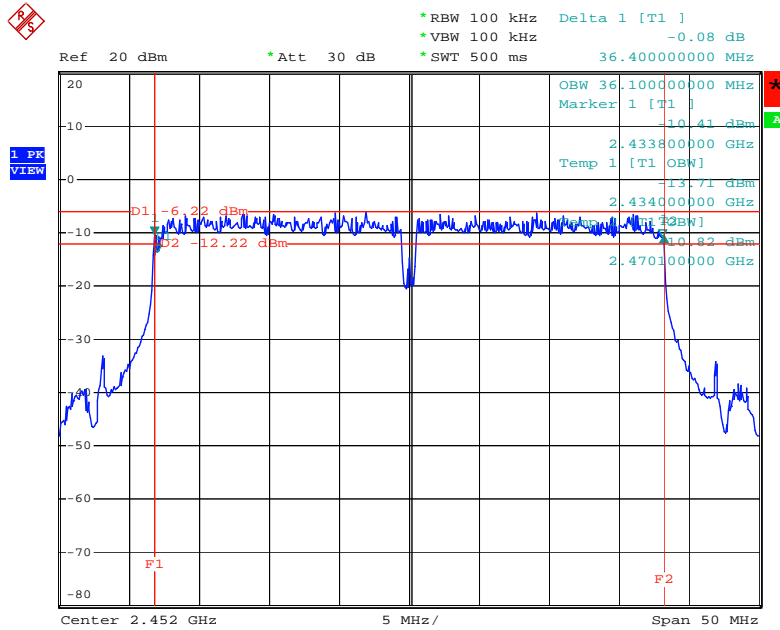

Date: 30.MAY.2007 12:53:53

3.5 Radiated Emissions Measurement

3.5.1 Limit

20dBc in any 100 kHz bandwidth outside the operating frequency band. In case the emission fall within the restricted band specified on 15.205(a), then the 15.209(a) limit in the table below has to be followed.

| Frequencies (MHz) | Field Strength (micorvolts/meter) | Measurement Distance (meters) |
|--------------------------|--|--------------------------------------|
| 0.009~0.490 | 2400/F(KHz) | 300 |
| 0.490~1.705 | 24000/F(KHz) | 30 |
| 1.705~30.0 | 30 | 30 |
| 30~88 | 100 | 3 |
| 88~216 | 150 | 3 |
| 216~960 | 200 | 3 |
| Above 960 | 500 | 3 |

3.5.2 Measuring Instruments and Setting

Please refer to section 4 of equipments list in this report. The following table is the setting of spectrum analyzer and receiver.

| Spectrum Parameter | Setting |
|---|--|
| Attenuation | Auto |
| Start Frequency | 1000 MHz |
| Stop Frequency | 10th carrier harmonic |
| RB / VB (Emission in restricted band) | 1MHz / 1MHz for Peak, 1 MHz / 10Hz for Average |
| RB / VB (Emission in non-restricted band) | 1000KHz / 1000KHz for peak |

| Receiver Parameter | Setting |
|---------------------------|----------------------------------|
| Attenuation | Auto |
| Start ~ Stop Frequency | 9kHz~150kHz / RB 200Hz for QP |
| Start ~ Stop Frequency | 150kHz~30MHz / RB 9kHz for QP |
| Start ~ Stop Frequency | 30MHz~1000MHz / RB 120kHz for QP |

3.5.3 Test Procedures

1. Configure the EUT according to ANSI C63.4. The EUT was placed on the top of the turntable 0.8 meter above ground. The phase center of the receiving antenna mounted on the top of a height-variable antenna tower was placed 3 meters far away from the turntable.
2. Power on the EUT and all the supporting units. The turntable was rotated by 360 degrees to determine the position of the highest radiation.
3. The height of the broadband receiving antenna was varied between one meter and four meters above ground to find the maximum emissions field strength of both horizontal and vertical polarization.
4. For each suspected emissions, the antenna tower was scan (from 1 M to 4 M) and then the turntable was rotated (from 0 degree to 360 degrees) to find the maximum reading.
5. Set the test-receiver system to Peak or CISPR quasi-peak Detect Function with specified bandwidth under Maximum Hold Mode.
6. For emissions above 1GHz, use 1MHz VBW and RBW for peak reading. Then 1MHz RBW and 10Hz VBW for average reading in spectrum analyzer.
7. When the radiated emissions limits are expressed in terms of the average value of the emissions, and pulsed operation is employed, the measurement field strength shall be determined by averaging over one complete pulse train, including blanking intervals, as long as the pulse train does not exceed 0.1 seconds. As an alternative (provided the transmitter operates for longer than 0.1 seconds) or in cases where the pulse train exceeds 0.1 seconds, the measured field strength shall be determined from the average absolute voltage during a 0.1 second interval during which the field strength is at its maximum value.
8. If the emissions level of the EUT in peak mode was 3 dB lower than the average limit specified, then testing will be stopped and peak values of EUT will be reported, otherwise, the emissions which do not have 3 dB margin will be repeated one by one using the quasi-peak method for below 1GHz.
9. For testing above 1GHz, the emissions level of the EUT in peak mode was lower than average limit (that means the emissions level in peak mode also complies with the limit in average mode), then testing will be stopped and peak values of EUT will be reported, otherwise, the emissions will be measured in average mode again and reported.
10. In case the emission is lower than 30MHz, loop antenna has to be used for measurement and the recorded data should be QP measured by receiver. High – Low scan is not required in this case.

3.5.4 Test Setup Layout

For radiated emissions below 30MHz

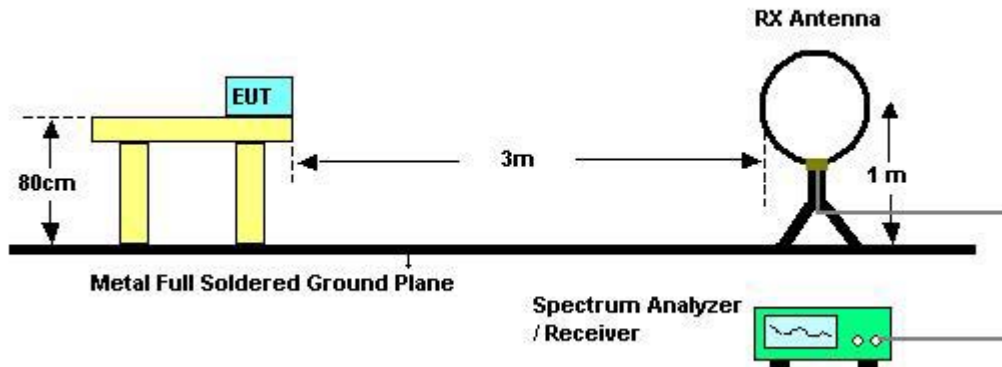

For radiated emissions above 30MHz

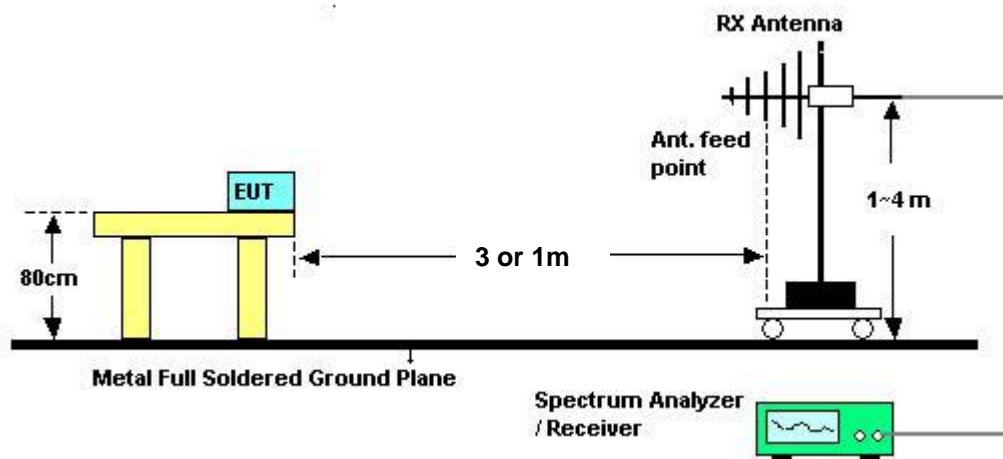

Above 10 GHz shall be extrapolated to the specified distance using an extrapolation factor of 20 dB/decade from 3m to 1m.

Distance extrapolation factor = $20 \log (\text{specific distance [3m]} / \text{test distance [1m]})$ (dB);

Limit line = specific limits (dBuV) + distance extrapolation factor [9.54 dB].

3.5.5 Test Deviation

There is no deviation with the original standard.

3.5.6 EUT Operation during Test

The EUT was programmed to be in continuously transmitting mode.

3.5.7 Results of Radiated Emissions (9kHz~30MHz)

| | | | |
|----------------------|-----|-----------------------|-------|
| Temperature | 25 | Humidity | 56% |
| Test Engineer | Vic | Configurations | MCS15 |

| Freq. (MHz) | Level (dBuV) | Over Limit (dB) | Limit Line (dBuV) | Remark |
|--------------------|---------------------|------------------------|--------------------------|---------------|
| - | - | - | - | See Note |

Note:

The amplitude of spurious emissions which are attenuated by more than 20 dB below the permissible value has no need to be reported.

Distance extrapolation factor = $40 \log(\text{specific distance} / \text{test distance})$ (dB);

Limit line = specific limits (dBuV) + distance extrapolation factor.

3.5.8 Results of Radiated Emissions (30MHz~1GHz)

| | | | |
|---------------|-----|----------------|--------------------|
| Temperature | 25 | Humidity | 56% |
| Test Engineer | Vic | Configurations | MCS15 (40MHz) Ch 6 |

Horizontal

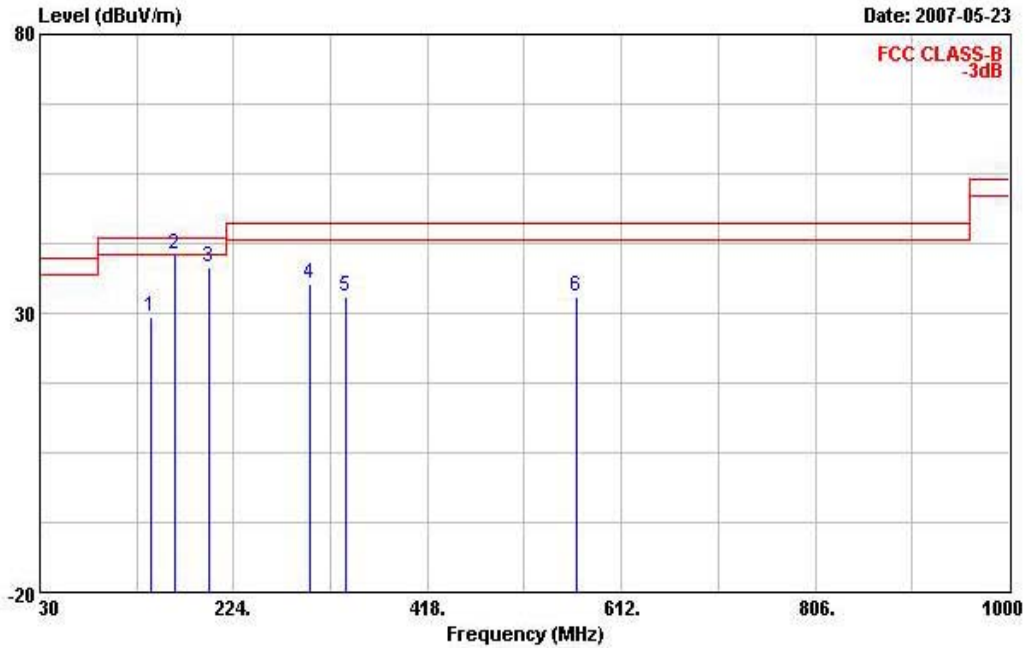

| | Freq | Level | Over Limit | Limit Line | Read Antenna Level | Antenna Factor | Cable Loss | Preamp Factor | Remark | Ant Pos | Table Pos |
|---|---------|--------|------------|------------|--------------------|----------------|------------|---------------|--------|---------|-----------|
| | MHz | dBuV/m | dB | dBuV/m | dBuV | dB/m | dB | dB | | cm | deg |
| 1 | 141.550 | 29.25 | -14.25 | 43.50 | 42.97 | 11.26 | 2.96 | 27.93 | Peak | --- | --- |
| 2 | 164.830 | 40.53 | -2.97 | 43.50 | 55.13 | 9.89 | 3.40 | 27.90 | QP | --- | --- |
| 3 | 198.780 | 38.24 | -5.26 | 43.50 | 53.19 | 9.61 | 3.54 | 28.09 | Peak | --- | --- |
| 4 | 299.660 | 35.27 | -10.73 | 46.00 | 46.42 | 13.58 | 3.81 | 28.54 | Peak | --- | --- |
| 5 | 335.550 | 33.07 | -12.93 | 46.00 | 42.79 | 14.67 | 4.25 | 28.63 | Peak | --- | --- |
| 6 | 567.380 | 32.97 | -13.03 | 46.00 | 38.47 | 19.30 | 4.78 | 29.57 | Peak | --- | --- |

Vertical

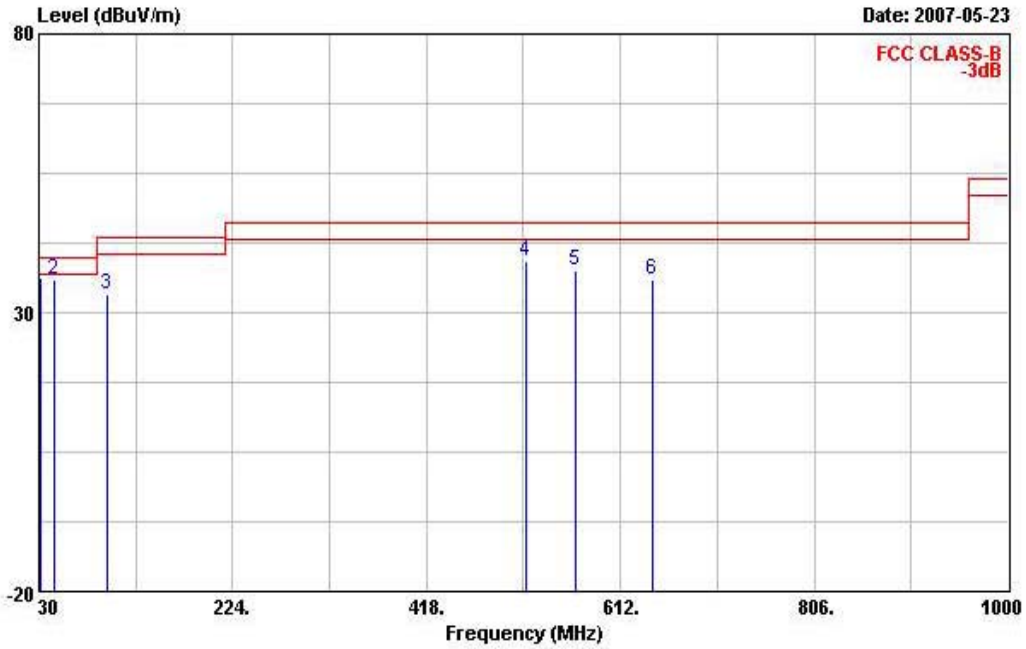

| | Freq | Level | Over Limit | Limit Line | ReadAntenna Level | Antenna Factor | Cable Loss | Preamp Factor | Remark | Ant Pos | Table Pos |
|---|---------|--------|------------|------------|-------------------|----------------|------------|---------------|--------|---------|-----------|
| | MHz | dBuV/m | dB | dBuV/m | dBuV | dB/m | dB | dB | | cm | deg |
| 1 | 31.940 | 36.31 | -3.69 | 40.00 | 44.53 | 17.30 | 2.16 | 27.68 | Peak | --- | --- |
| 2 | 44.550 | 36.01 | -3.99 | 40.00 | 49.99 | 10.51 | 3.27 | 27.76 | Peak | --- | --- |
| 3 | 98.870 | 33.21 | -10.29 | 43.50 | 47.03 | 11.03 | 2.86 | 27.71 | Peak | --- | --- |
| 4 | 517.910 | 39.37 | -6.63 | 46.00 | 45.75 | 18.55 | 4.34 | 29.27 | Peak | --- | --- |
| 5 | 567.380 | 37.54 | -8.46 | 46.00 | 43.04 | 19.30 | 4.78 | 29.57 | Peak | --- | --- |
| 6 | 644.980 | 35.88 | -10.12 | 46.00 | 41.09 | 19.60 | 5.00 | 29.80 | Peak | --- | --- |

Note:

The amplitude of spurious emissions which are attenuated by more than 20 dB below the permissible value has no need to be reported.

Emission level (dBuV/m) = 20 log Emission level (uV/m).

Corrected Reading: Antenna Factor + Cable Loss + Read Level - Preamp Factor = Level.

Pol. : V is Vertical Polarization ; H is Horizontal Polarization.

3.5.9 Results for Radiated Emissions (1GHz~10th Harmonic)

| | | | |
|---------------|-----|----------------|--------------------|
| Temperature | 25 | Humidity | 56% |
| Test Engineer | Vic | Configurations | MCS15 (20MHz) Ch 1 |

Horizontal

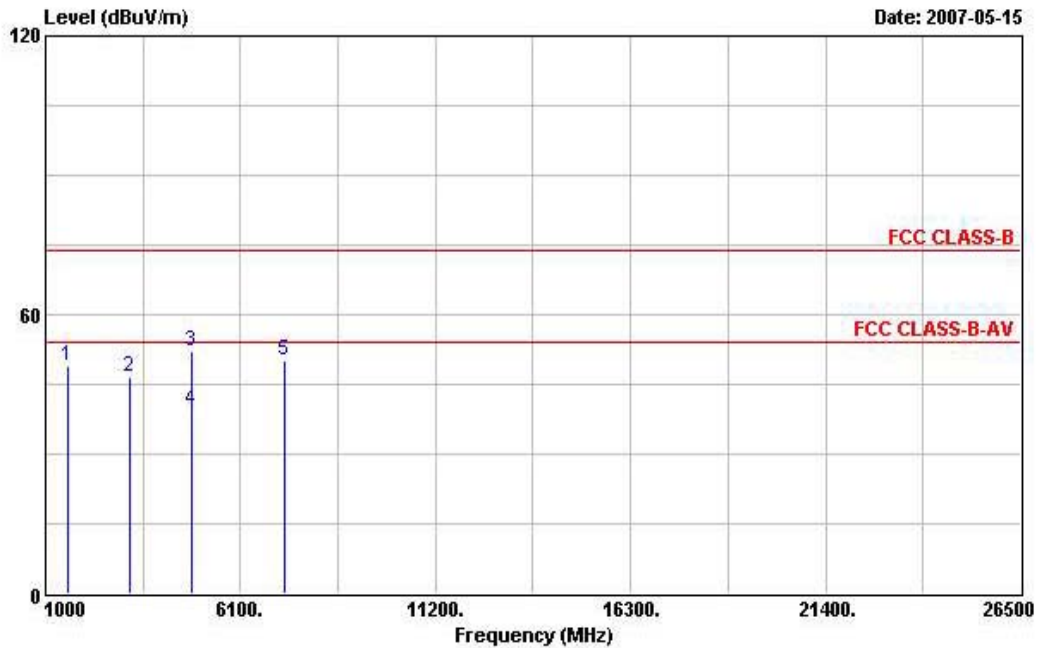

| | Freq | Level | Over | Limit | ReadAntenna | Cable | Preamp | | Ant | Table |
|---|----------|--------|--------|--------|-------------|-------|--------|---------------|-----|-------|
| | MHz | dBuV/m | Limit | Line | Level | Loss | Factor | Remark | Pos | Pos |
| | | | dB | dBuV/m | dBuV | dB | dB | | cm | deg |
| 1 | 1604.000 | 49.11 | -4.89 | 54.00 | 53.97 | 25.89 | 2.25 | 33.00 Average | --- | --- |
| 2 | 3216.000 | 46.53 | | | 45.35 | 30.51 | 3.38 | 32.71 | --- | --- |
| 3 | 4824.000 | 52.16 | -21.84 | 74.00 | 47.09 | 33.06 | 4.35 | 32.32 PEAK | --- | --- |
| 4 | 4824.000 | 39.39 | -14.61 | 54.00 | 34.31 | 33.06 | 4.35 | 32.32 Average | --- | --- |
| 5 | 7232.000 | 50.05 | | | 41.65 | 35.78 | 5.18 | 32.55 | --- | --- |

Note: An item 2 and 5 are on un-restricted band, so the limit is -20dBc for the field strength of the fundamental emissions (see section 3.6.7).

Vertical

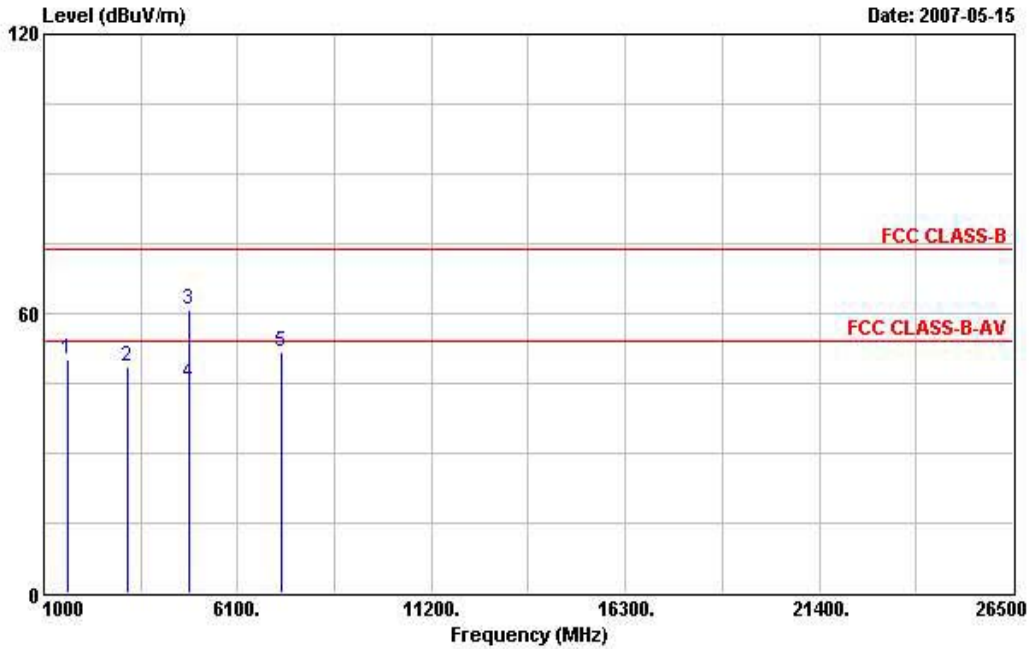

| | Freq | Level | Over | Limit | ReadAntenna | Cable | Preamp | | Ant | Table | |
|-----|----------|--------|--------|--------|-------------|-------|--------|-------|---------|-------|-----|
| | MHz | dBuV/m | dB | dBuV/m | dBuV | dB/m | dB | dB | cm | deg | |
| 1 | 1608.000 | 50.18 | -3.82 | 54.00 | 55.00 | 25.89 | 2.28 | 33.00 | Average | --- | --- |
| 2 | 3216.000 | 48.52 | | | 47.33 | 30.51 | 3.38 | 32.71 | | --- | --- |
| 3 | 4828.000 | 60.71 | -13.29 | 74.00 | 55.63 | 33.06 | 4.35 | 32.32 | PEAK | --- | --- |
| 4 | 4828.000 | 45.05 | -8.95 | 54.00 | 39.97 | 33.06 | 4.35 | 32.32 | Average | --- | --- |
| 5 @ | 7236.000 | 51.76 | | | 43.37 | 35.78 | 5.18 | 32.57 | | --- | --- |

Note: An item 2 and 5 are on un-restricted band, so the limit is -20dBc for the field strength of the fundamental emissions (see section 3.6.7).

| | | | |
|---------------|-----|----------------|--------------------|
| Temperature | 25 | Humidity | 56% |
| Test Engineer | Vic | Configurations | MCS15 (20MHz) Ch 6 |

Horizontal

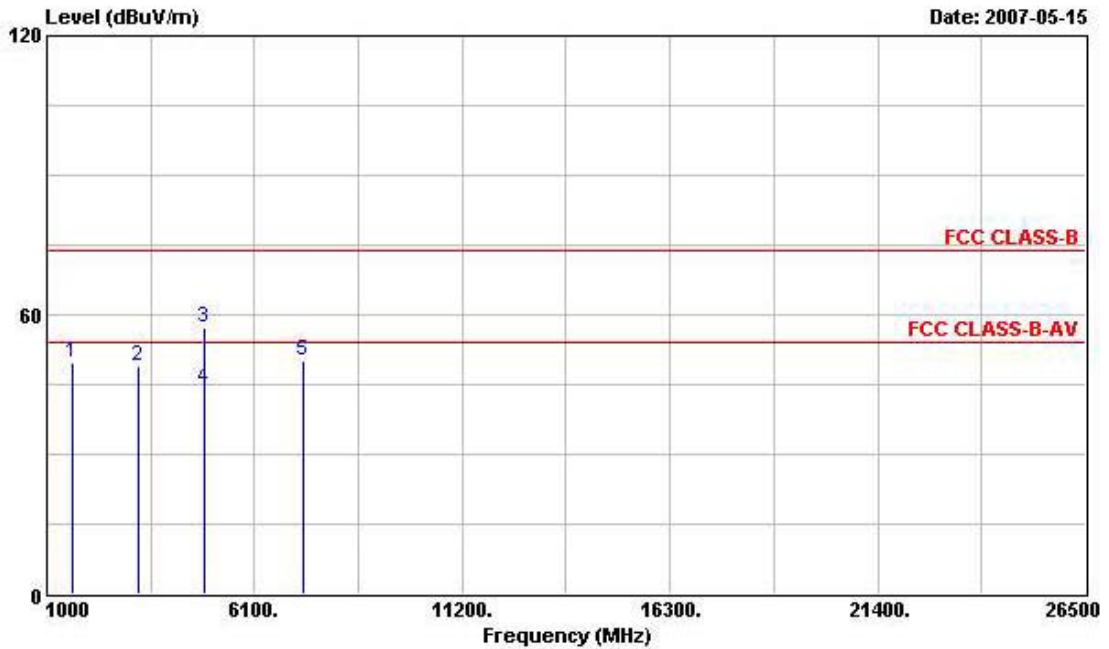

| | Freq | Level | Over Limit | Limit Line | ReadAntenna Level | Antenna Factor | Cable Loss | Preamp Factor | Remark | Ant Pos | Table Pos |
|---|----------|--------|------------|------------|-------------------|----------------|------------|---------------|---------|---------|-----------|
| | MHz | dBuV/m | dB | dBuV/m | dBuV | dB/m | dB | dB | | cm | deg |
| 1 | 1624.000 | 49.62 | -4.38 | 54.00 | 54.38 | 25.96 | 2.28 | 33.00 | Average | --- | --- |
| 2 | 3248.000 | 48.87 | | | 47.59 | 30.58 | 3.40 | 32.71 | | --- | --- |
| 3 | 4868.000 | 57.31 | -16.69 | 74.00 | 52.09 | 33.16 | 4.36 | 32.30 | PEAK | --- | --- |
| 4 | 4868.000 | 44.19 | -9.81 | 54.00 | 38.97 | 33.16 | 4.36 | 32.30 | Average | --- | --- |
| 5 | 7307.000 | 49.94 | -4.06 | 54.00 | 41.29 | 35.94 | 5.30 | 32.59 | Average | --- | --- |

Note: An item 2 is on un-restricted band, so the limit is -20dBc for the field strength of the fundamental emissions (see section 3.6.7).

Vertical

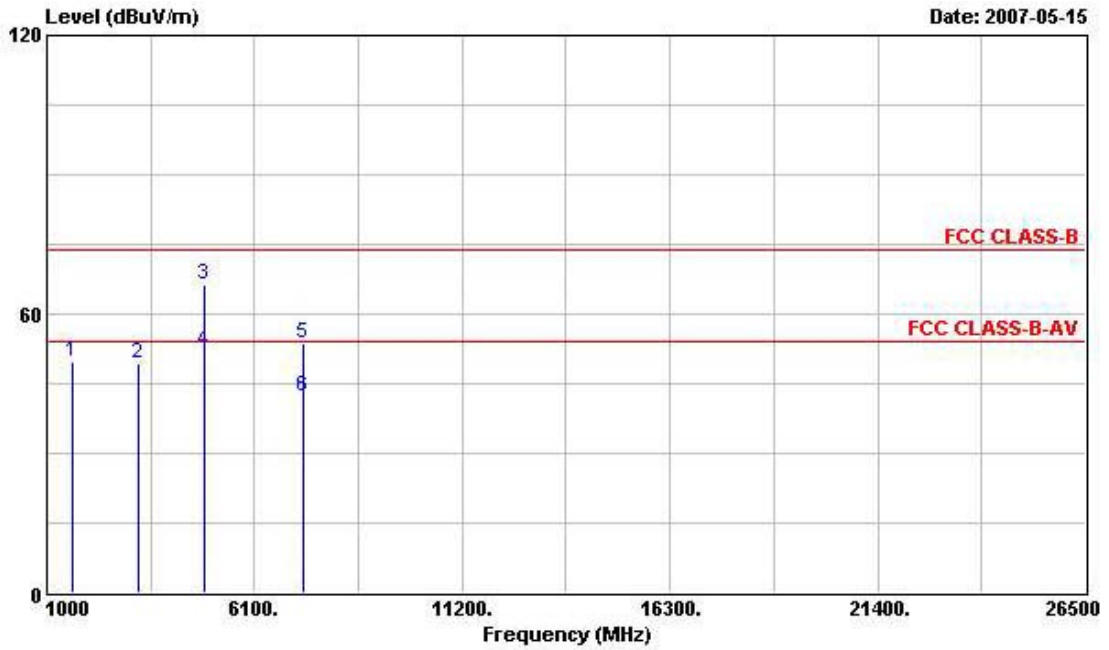

| | Freq | Level | Over Limit | Limit Line | ReadAntenna Level | Antenna Factor | Cable Loss | Preamplifier | Remark | Ant Pos | Table Pos |
|---|----------|--------|------------|------------|-------------------|----------------|------------|--------------|---------|---------|-----------|
| | MHz | dBuV/m | dB | dBuV/m | dBuV | dB/m | dB | dB | | cm | deg |
| 1 | 1616.000 | 49.73 | -4.27 | 54.00 | 54.55 | 25.89 | 2.28 | 33.00 | Average | --- | --- |
| 2 | 3248.000 | 49.23 | | | 47.95 | 30.58 | 3.40 | 32.71 | | --- | --- |
| 3 | 4876.000 | 66.19 | -7.81 | 74.00 | 60.97 | 33.16 | 4.36 | 32.30 | PEAK | --- | --- |
| 4 | 4876.000 | 52.30 | -1.70 | 54.00 | 47.08 | 33.16 | 4.36 | 32.30 | Average | --- | --- |
| 5 | 7312.000 | 53.69 | -20.31 | 74.00 | 45.05 | 35.94 | 5.30 | 32.61 | PEAK | --- | --- |
| 6 | 7312.000 | 42.26 | -11.74 | 54.00 | 33.62 | 35.94 | 5.30 | 32.61 | Average | --- | --- |

Note: An item 2 is on un-restricted band, so the limit is -20dBc for the field strength of the fundamental emissions (see section 3.6.7).

| | | | |
|---------------|-----|----------------|---------------------|
| Temperature | 25 | Humidity | 56% |
| Test Engineer | Vic | Configurations | MCS15 (20MHz) Ch 11 |

Horizontal

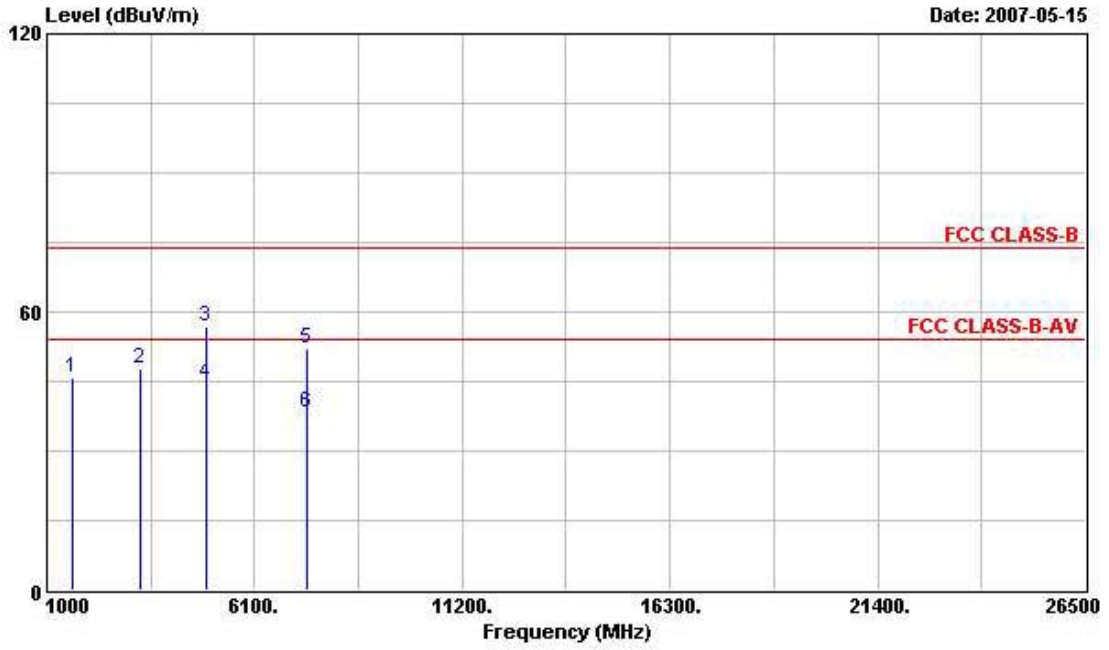

| | Freq | Level | Over Limit | Limit Line | ReadAntenna Level | Antenna Factor | Cable Loss | Preamp Factor | Remark | Ant Pos | Table Pos |
|---|----------|--------|------------|------------|-------------------|----------------|------------|---------------|---------|---------|-----------|
| | MHz | dBuV/m | dB | dBuV/m | dBuV | dB/m | dB | dB | | cm | deg |
| 1 | 1638.000 | 45.64 | | | 50.30 | 26.03 | 2.28 | 32.97 | | --- | --- |
| 2 | 3280.000 | 47.74 | | | 46.39 | 30.65 | 3.40 | 32.70 | | --- | --- |
| 3 | 4920.000 | 56.93 | -17.07 | 74.00 | 51.55 | 33.26 | 4.40 | 32.28 | PEAK | --- | --- |
| 4 | 4920.000 | 44.56 | -9.44 | 54.00 | 39.18 | 33.26 | 4.40 | 32.28 | Average | --- | --- |
| 5 | 7382.000 | 51.95 | -22.05 | 74.00 | 43.06 | 36.11 | 5.41 | 32.63 | PEAK | --- | --- |
| 6 | 7382.000 | 38.25 | -15.75 | 54.00 | 29.36 | 36.11 | 5.41 | 32.63 | Average | --- | --- |

Note: An item 1 and 2 are on un-restricted band, so the limit is -20dBc for the field strength of the fundamental emissions (see section 3.6.7).

Vertical

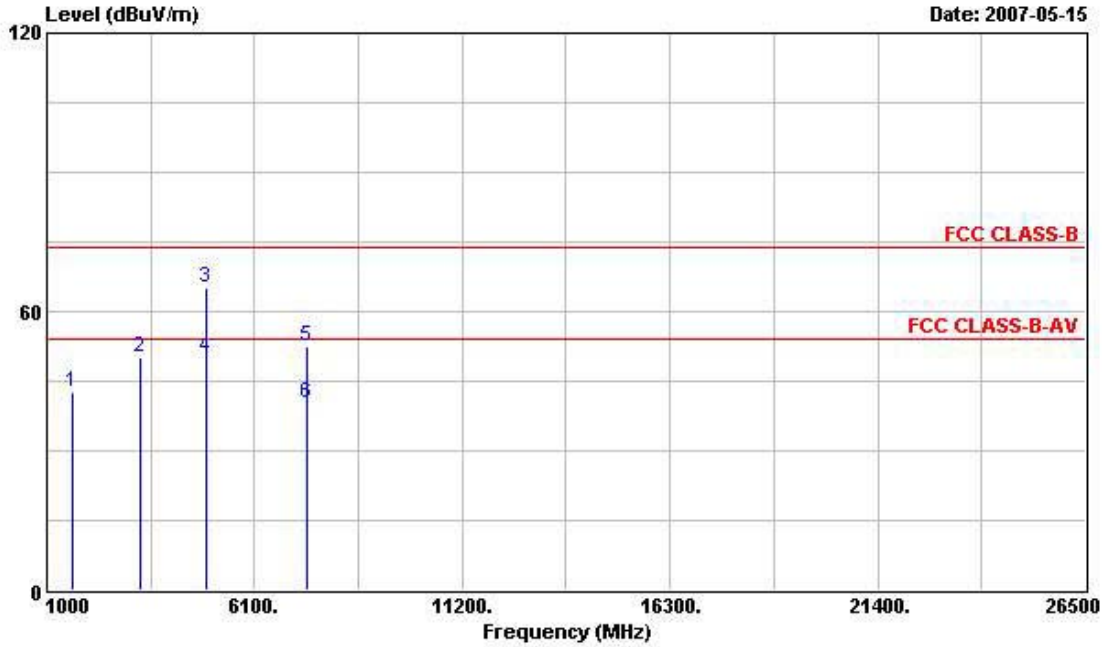

| | Freq | Level | Over Limit | Limit Line | Read Level | Antenna Factor | Cable Loss | Preamplifier | Remark | Ant Pos | Table Pos |
|---|----------|--------|------------|------------|------------|----------------|------------|--------------|---------|---------|-----------|
| | MHz | dBuV/m | dB | dBuV/m | dBuV | dB/m | dB | dB | | cm | deg |
| 1 | 1638.000 | 42.73 | | | 47.39 | 26.03 | 2.28 | 32.97 | | --- | --- |
| 2 | 3280.000 | 50.19 | | | 48.84 | 30.65 | 3.40 | 32.70 | | --- | --- |
| 3 | 4928.000 | 64.94 | -9.06 | 74.00 | 59.55 | 33.26 | 4.40 | 32.28 | PEAK | --- | --- |
| 4 | 4928.000 | 49.95 | -4.05 | 54.00 | 44.57 | 33.26 | 4.40 | 32.28 | Average | --- | --- |
| 5 | 7378.400 | 52.49 | -21.51 | 74.00 | 43.60 | 36.11 | 5.41 | 32.63 | PEAK | --- | --- |
| 6 | 7378.400 | 40.22 | -13.78 | 54.00 | 31.33 | 36.11 | 5.41 | 32.63 | Average | --- | --- |

Note: An item 1 and 2 are on un-restricted band, so the limit is -20dBc for the field strength of the fundamental emissions (see section 3.6.7).

| | | | |
|---------------|-----|----------------|--------------------|
| Temperature | 25 | Humidity | 56% |
| Test Engineer | Vic | Configurations | MCS15 (40MHz) Ch 3 |

Horizontal

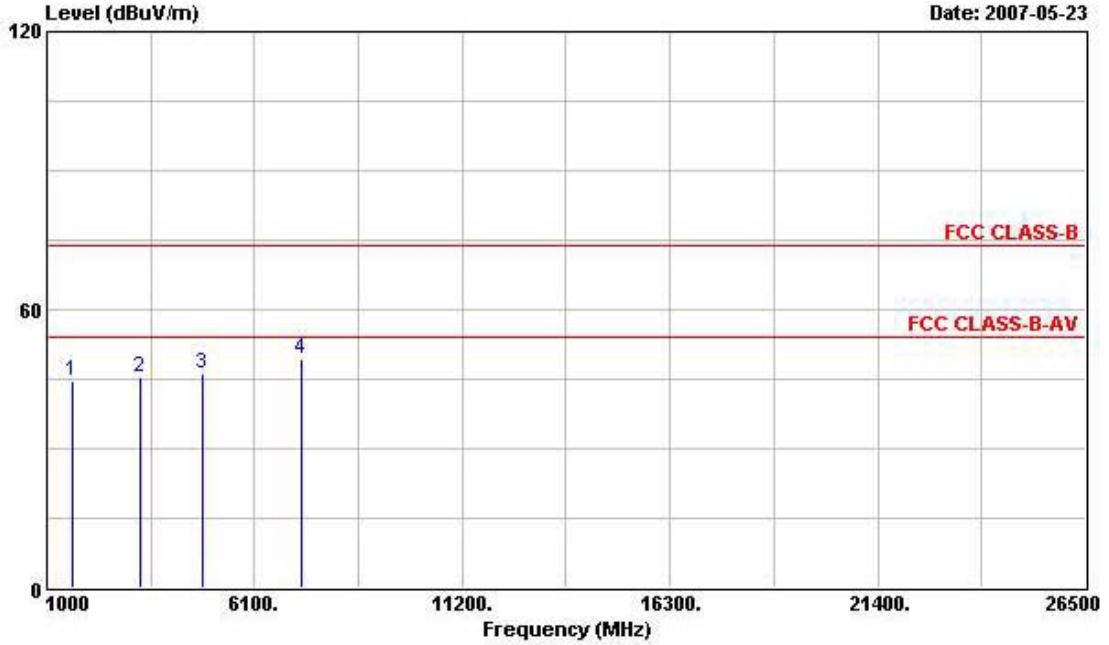

| | Freq | Level | Over Limit | Limit Line | ReadAntenna Level | Antenna Factor | Cable Loss | Preamp Factor | Remark | Ant Pos | Table Pos |
|---|----------|--------|------------|------------|-------------------|----------------|------------|---------------|---------|---------|-----------|
| | MHz | dBuV/m | dB | dBuV/m | dBuV | dB/m | dB | dB | | cm | deg |
| 1 | 1616.000 | 44.57 | -9.43 | 54.00 | 49.39 | 25.89 | 2.28 | 33.00 | Average | --- | --- |
| 2 | 3280.000 | 45.39 | | | 44.04 | 30.65 | 3.40 | 32.70 | | --- | --- |
| 3 | 4840.000 | 46.32 | -7.68 | 54.00 | 41.19 | 33.09 | 4.35 | 32.31 | Average | --- | --- |
| 4 | 7262.000 | 49.50 | -4.50 | 54.00 | 41.01 | 35.82 | 5.24 | 32.58 | Average | --- | --- |

Note: An item 2 is on un-restricted band, so the limit is -20dBc for the field strength of the fundamental emissions (see section 3.6.7).

Vertical

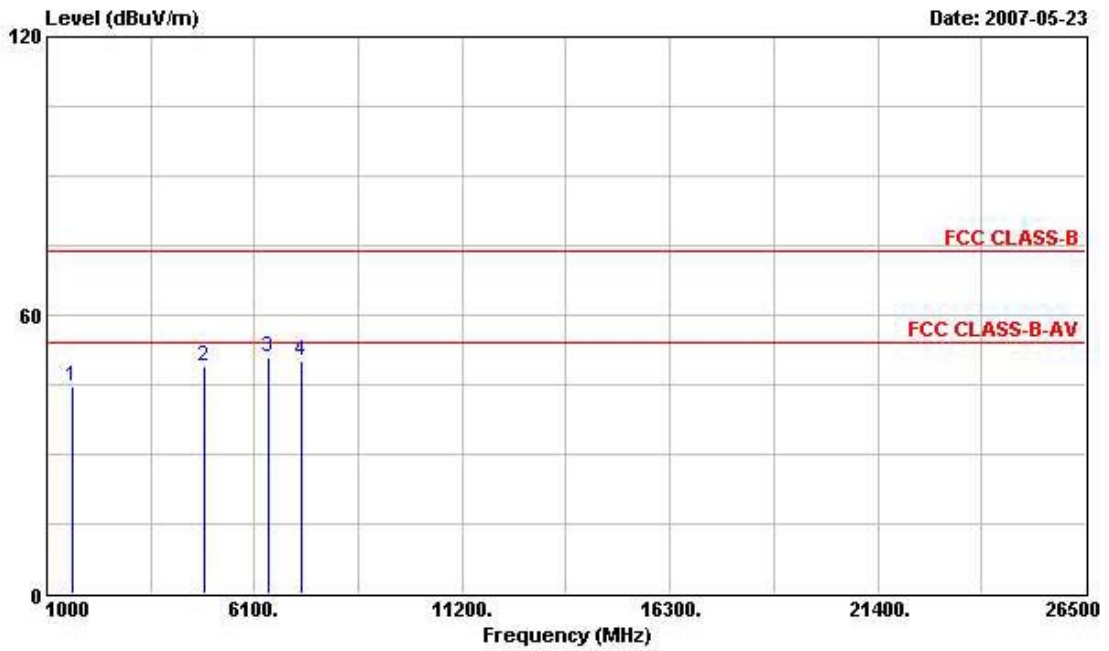

| | Freq | Level | Over Limit | Limit Line | ReadAntenna Level | Antenna Factor | Cable Loss | Preamp Factor | Remark | Ant Pos | Table Pos |
|-----|----------|--------|------------|------------|-------------------|----------------|------------|---------------|---------|---------|-----------|
| | MHz | dBuV/m | dB | dBuV/m | dBuV | dB/m | dB | dB | | cm | deg |
| 1 | 1612.000 | 44.50 | -9.50 | 54.00 | 49.33 | 25.89 | 2.28 | 33.00 | Average | --- | --- |
| 2 | 4848.000 | 49.10 | | | 43.96 | 33.09 | 4.36 | 32.31 | | --- | --- |
| 3 @ | 6460.000 | 50.77 | | | 44.16 | 34.19 | 4.98 | 32.56 | | --- | --- |
| 4 | 7262.000 | 50.05 | -3.95 | 54.00 | 41.57 | 35.82 | 5.24 | 32.58 | Average | --- | --- |

Note: An item 2 and 3 are on un-restricted band, so the limit is -20dBc for the field strength of the fundamental emissions (see section 3.6.7).

| | | | |
|---------------|-----|----------------|--------------------|
| Temperature | 25 | Humidity | 56% |
| Test Engineer | Vic | Configurations | MCS15 (40MHz) Ch 6 |

Horizontal

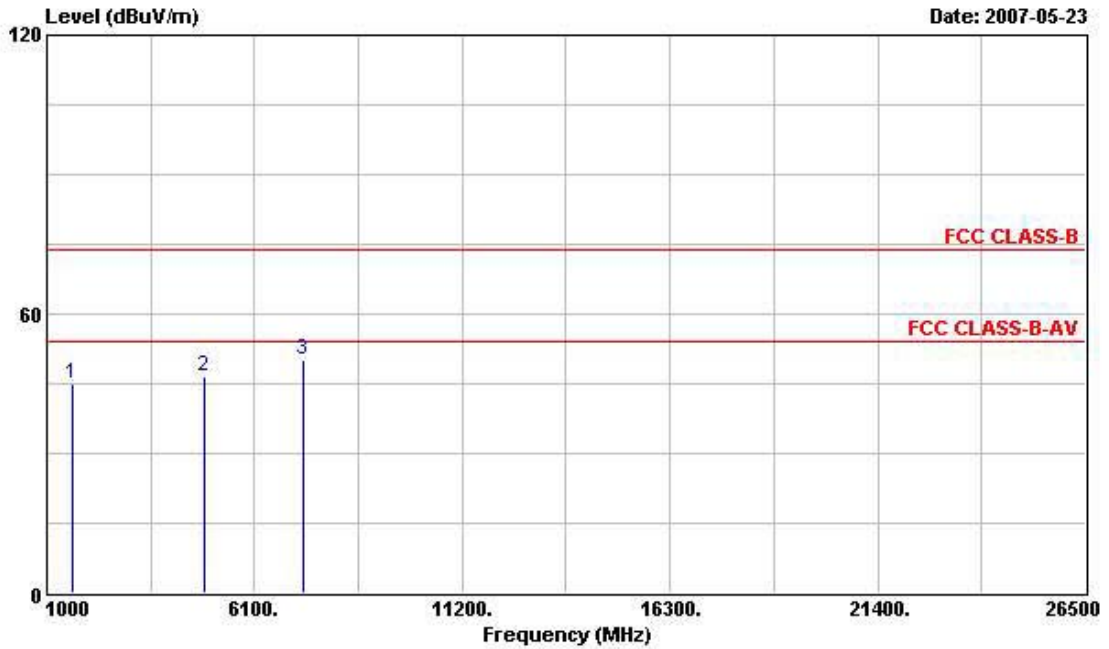

| | Freq | Level | Over Limit | Limit Line | ReadAntenna Level | Antenna Factor | Cable Loss | Preamplifier | Remark | Ant Pos | Table Pos |
|---|----------|--------|------------|------------|-------------------|----------------|------------|--------------|---------|---------|-----------|
| | MHz | dBuV/m | dB | dBuV/m | dBuV | dB/m | dB | dB | | cm | deg |
| 1 | 1624.000 | 44.99 | -9.01 | 54.00 | 49.75 | 25.96 | 2.28 | 33.00 | Average | --- | --- |
| 2 | 4874.000 | 46.77 | -7.23 | 54.00 | 41.55 | 33.16 | 4.36 | 32.30 | Average | --- | --- |
| 3 | 7311.000 | 49.94 | -4.06 | 54.00 | 41.29 | 35.94 | 5.30 | 32.59 | Average | --- | --- |

Vertical

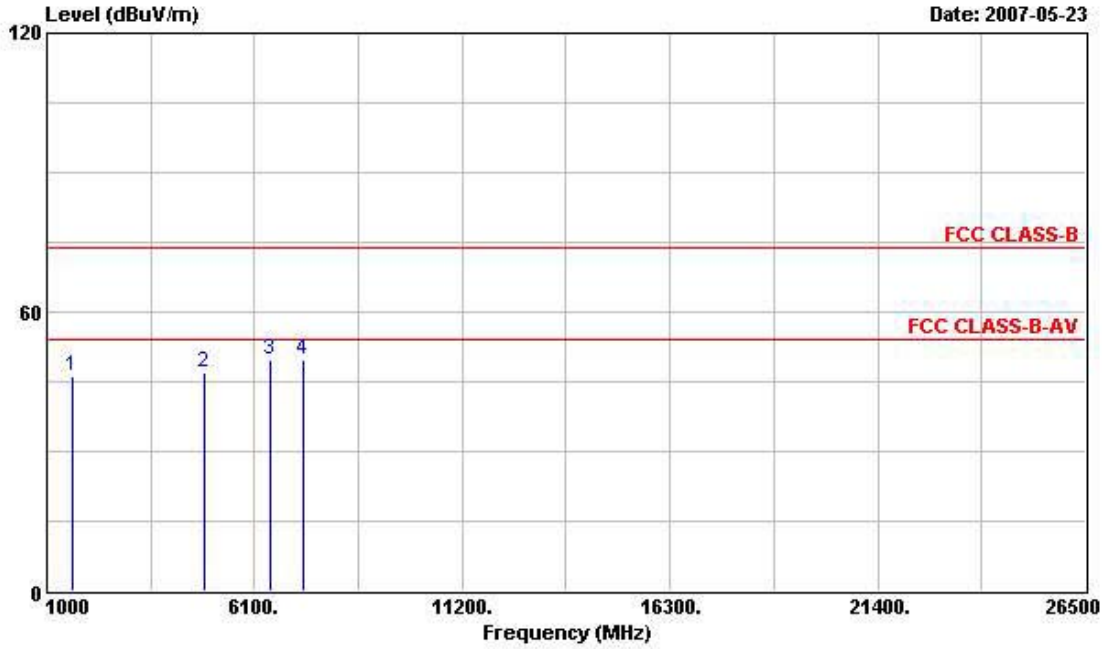

| | Freq | Level | Over Limit | Limit Line | ReadAntenna Level | Antenna Factor | Cable Loss | Preamp Factor | Remark | Ant Pos | Table Pos |
|---|----------|--------|------------|------------|-------------------|----------------|------------|---------------|---------|---------|-----------|
| | MHz | dBuV/m | dB | dBuV/m | dBuV | dB/m | dB | dB | | cm | deg |
| 1 | 1628.000 | 46.36 | | | 51.08 | 25.96 | 2.28 | 32.97 | | --- | --- |
| 2 | 4878.000 | 46.83 | -7.17 | 54.00 | 41.61 | 33.16 | 4.36 | 32.30 | Average | --- | --- |
| 3 | 6500.000 | 49.57 | | | 42.99 | 34.20 | 4.97 | 32.59 | | --- | --- |
| 4 | 7315.000 | 49.72 | -4.28 | 54.00 | 41.08 | 35.94 | 5.30 | 32.61 | Average | --- | --- |

Note: An item 1 and 3 are on un-restricted band, so the limit is -20dBc for the field strength of the fundamental emissions (see section 3.6.7).

| | | | |
|---------------|-----|----------------|--------------------|
| Temperature | 25 | Humidity | 56% |
| Test Engineer | Vic | Configurations | MCS15 (40MHz) Ch 9 |

Horizontal

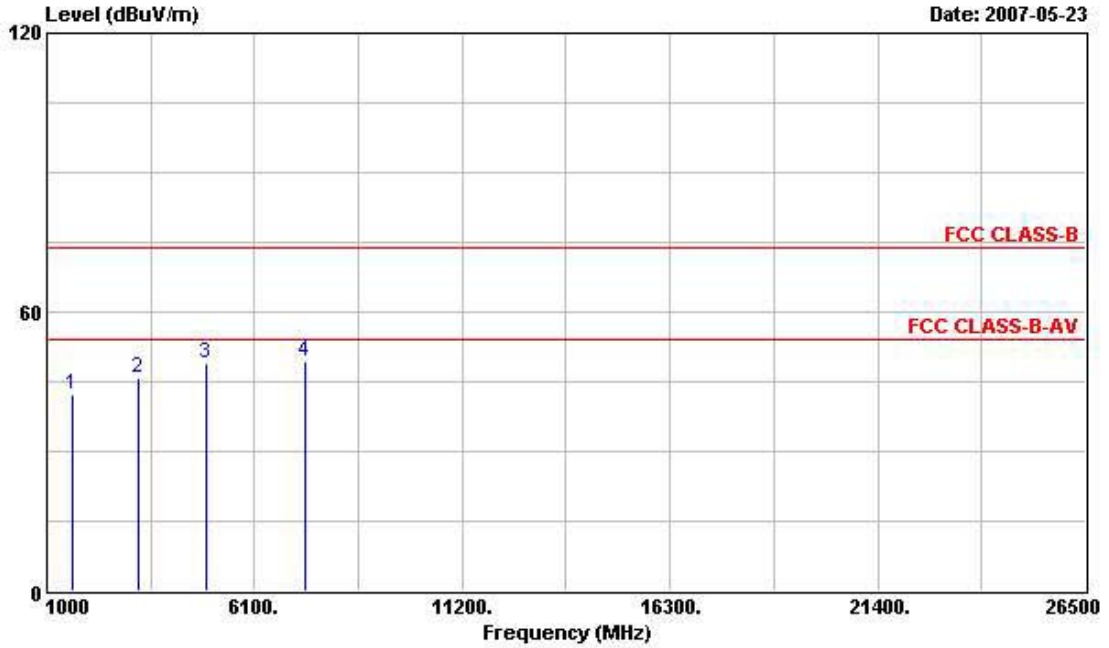

| | Freq | Level | Over Limit | Limit Line | Read Level | Antenna Factor | Cable Loss | Preamp Factor | Remark | Ant Pos | Table Pos |
|---|----------|--------|------------|------------|------------|----------------|------------|---------------|---------|---------|-----------|
| | MHz | dBuV/m | dB | dBuV/m | dBuV | dB/m | dB | dB | | cm | deg |
| 1 | 1630.000 | 42.19 | | | 46.92 | 25.96 | 2.28 | 32.97 | | --- | --- |
| 2 | 3268.000 | 45.84 | | | 44.52 | 30.62 | 3.40 | 32.70 | | --- | --- |
| 3 | 4908.000 | 48.96 | -5.04 | 54.00 | 43.64 | 33.23 | 4.38 | 32.29 | Average | --- | --- |
| 4 | 7360.000 | 49.26 | -4.74 | 54.00 | 40.45 | 36.07 | 5.36 | 32.62 | Average | --- | --- |

Note: An item 1 and 2 are on un-restricted band, so the limit is -20dBc for the field strength of the fundamental emissions (see section 3.6.7).

Vertical

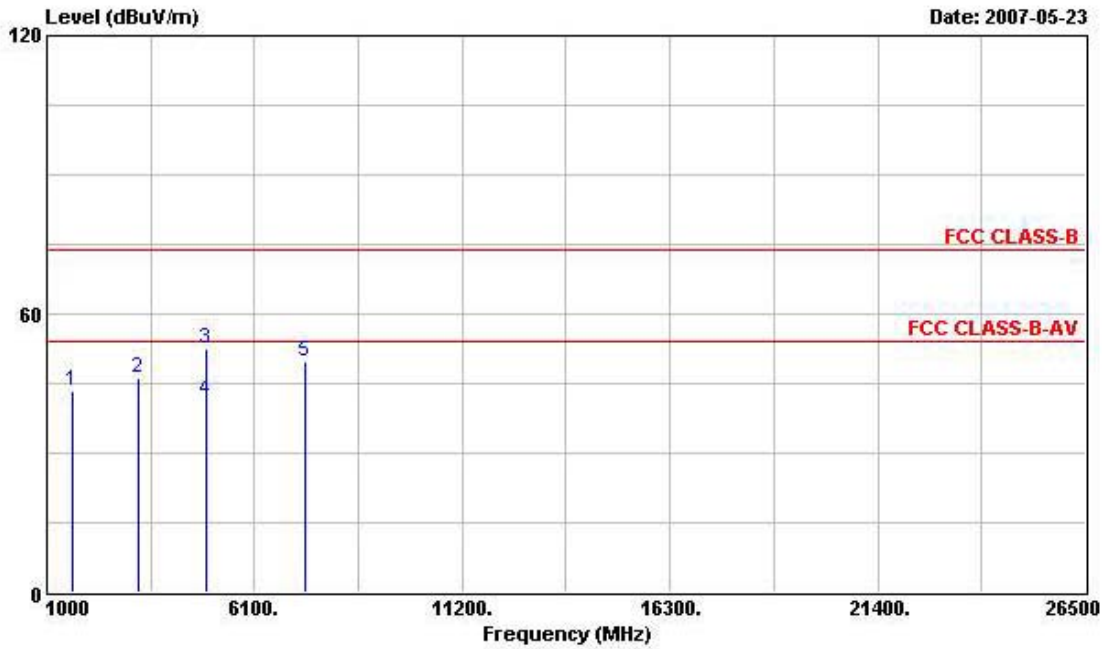

| | Freq | Level | Over Limit | Limit Line | Read Level | Antenna Factor | Cable Loss | Preamp Factor | Remark | Ant Pos | Table Pos |
|---|----------|--------|------------|------------|------------|----------------|------------|---------------|---------|---------|-----------|
| | MHz | dBuV/m | dB | dBuV/m | dBuV | dB/m | dB | dB | | cm | deg |
| 1 | 1636.000 | 43.45 | | | 48.18 | 25.96 | 2.28 | 32.97 | | --- | --- |
| 2 | 3268.000 | 46.00 | | | 44.68 | 30.62 | 3.40 | 32.70 | | --- | --- |
| 3 | 4908.000 | 52.66 | -21.34 | 74.00 | 47.35 | 33.23 | 4.38 | 32.29 | Peak | --- | --- |
| 4 | 4908.000 | 41.36 | -12.64 | 54.00 | 36.04 | 33.23 | 4.38 | 32.29 | Average | --- | --- |
| 5 | 7356.000 | 49.82 | -4.18 | 54.00 | 41.01 | 36.07 | 5.36 | 32.62 | Average | --- | --- |

Note: An Items 1 and 2 are on un-restricted band, so the limit is -20dBc for the field strength of the fundamental emissions (see section 3.6.7).

The amplitude of spurious emissions which are attenuated by more than 20 dB below the permissible value has no need to be reported.

Emission level (dBuV/m) = 20 log Emission level (uV/m).

Corrected Reading: Antenna Factor + Cable Loss + Read Level - Preamp Factor = Level.

Note: Items 1 and 2 are on un-restricted band, so the limit is -20dBc for the field strength of the fundamental emissions (see section 3.6.7).

3.6 Band Edge Emissions Measurement

3.6.1 Limit

20dBc in any 100 kHz bandwidth outside the operating frequency band. In case the emission fall within the restricted band specified on 15.205(a), then the 15.209(a) limit in the table below has to be followed.

| Frequencies (MHz) | Field Strength (micровolts/meter) | Measurement Distance (meters) |
|--------------------------|--|--------------------------------------|
| 0.009~0.490 | 2400/F(KHz) | 300 |
| 0.490~1.705 | 24000/F(KHz) | 30 |
| 1.705~30.0 | 30 | 30 |
| 30~88 | 100 | 3 |
| 88~216 | 150 | 3 |
| 216~960 | 200 | 3 |
| Above 960 | 500 | 3 |

3.6.2 Measuring Instruments and Setting

Please refer to section 4 of equipments list in this report. The following table is the setting of the spectrum analyzer.

| Spectrum Parameter | Setting |
|---|--|
| Attenuation | Auto |
| Span Frequency | 100 MHz |
| RB / VB (Emission in restricted band) | 1MHz / 1MHz for Peak, 1 MHz / 10Hz for Average |
| RB / VB (Emission in non-restricted band) | 100 KHz /100 KHz for Peak |

3.6.3 Test Procedures

1. The test procedure is the same as section 3.5.3; only the frequency range investigated is limited to 100MHz around bandedges.
2. In case the emission is fail due to the used RB/VB is too wide, marker-delta method of FCC Public Notice DA00-705 will be followed.

3.6.4 Test Setup Layout

This test setup layout is the same as that shown in section 3.5.4.

3.6.5 Test Deviation

There is no deviation with the original standard.

3.6.6 EUT Operation during Test

The EUT was programmed to be in continuously transmitting mode.

3.6.7 Test Result of Band Edge and Fundamental Emissions

| | | | |
|----------------------|-----|-----------------------|---------------------------|
| Temperature | 25 | Humidity | 56% |
| Test Engineer | Vic | Configurations | MCS15 (20MHz) CH 1, 6, 11 |

Channel 1

| | Freq | Level | Over Limit | Limit Line | ReadAntenna Level | Antenna Factor | Cable Loss | Preamp Factor | Remark | Ant Pos | Table Pos |
|-----|----------|--------|------------|------------|-------------------|----------------|------------|---------------|---------|---------|-----------|
| | MHz | dBuV/m | dB | dBuV/m | dBuV | dB/m | dB | dB | | cm | deg |
| 1 | 2390.000 | 65.42 | -8.58 | 74.00 | 34.30 | 28.29 | 2.82 | 0.00 | Peak | --- | --- |
| 2 # | 2406.140 | 107.53 | | | 76.38 | 28.33 | 2.82 | 0.00 | Peak | --- | --- |
| 1 | 2390.000 | 51.92 | -2.08 | 54.00 | 20.80 | 28.29 | 2.82 | 0.00 | Average | --- | --- |
| 2 @ | 2406.140 | 97.68 | | | 66.53 | 28.33 | 2.82 | 0.00 | Average | --- | --- |

An item 2 is fundamental.

Channel 6

| | Freq | Level | Over Limit | Limit Line | ReadAntenna Level | Antenna Factor | Cable Loss | Preamp Factor | Remark | Ant Pos | Table Pos |
|-----|----------|--------|------------|------------|-------------------|----------------|------------|---------------|---------|---------|-----------|
| | MHz | dBuV/m | dB | dBuV/m | dBuV | dB/m | dB | dB | | cm | deg |
| 1 # | 2444.330 | 108.24 | | | 77.00 | 28.40 | 2.85 | 0.00 | Peak | --- | --- |
| 1 @ | 2444.330 | 99.17 | | | 67.93 | 28.40 | 2.85 | 0.00 | Average | --- | --- |

An item 1 is fundamental.

Channel 11

| | Freq | Level | Over Limit | Limit Line | ReadAntenna Level | Antenna Factor | Cable Loss | Preamp Factor | Remark | Ant Pos | Table Pos |
|-----|----------|--------|------------|------------|-------------------|----------------|------------|---------------|---------|---------|-----------|
| | MHz | dBuV/m | dB | dBuV/m | dBuV | dB/m | dB | dB | | cm | deg |
| 1 # | 2454.780 | 109.05 | | | 77.77 | 28.43 | 2.85 | 0.00 | Peak | --- | --- |
| 2 | 2483.500 | 68.13 | -5.87 | 74.00 | 36.79 | 28.47 | 2.87 | 0.00 | Peak | --- | --- |
| 1 @ | 2454.780 | 100.43 | | | 69.15 | 28.43 | 2.85 | 0.00 | Average | --- | --- |
| 2 | 2483.500 | 52.53 | -1.47 | 54.00 | 21.19 | 28.47 | 2.87 | 0.00 | Average | --- | --- |

An item 1 is fundamental.

| | | | |
|---------------|-----|----------------|--------------------------|
| Temperature | 25 | Humidity | 56% |
| Test Engineer | Vic | Configurations | MCS15 (40MHz) CH 3, 6, 9 |

Channel 3

| | Freq | Level | Over Limit | Limit Line | Read Level | Antenna Factor | Cable Loss | Preamp Factor | Remark | Ant Pos | Table Pos |
|-----|----------|--------|------------|------------|------------|----------------|------------|---------------|---------|---------|-----------|
| | MHz | dBuV/m | dB | dBuV/m | dBuV | dB/m | dB | dB | | cm | deg |
| 1 | 2389.610 | 71.20 | -2.80 | 74.00 | 40.08 | 28.29 | 2.82 | 0.00 | Peak | --- | --- |
| 2 # | 2418.490 | 101.59 | | | 70.44 | 28.33 | 2.82 | 0.00 | Peak | --- | --- |
| 1 | 2389.610 | 52.40 | -1.60 | 54.00 | 21.28 | 28.29 | 2.82 | 0.00 | Average | --- | --- |
| 2 @ | 2418.490 | 91.87 | | | 60.72 | 28.33 | 2.82 | 0.00 | Average | --- | --- |

An item 2 is fundamental.

Channel 6

| | Freq | Level | Over Limit | Limit Line | Read Level | Antenna Factor | Cable Loss | Preamp Factor | Remark | Ant Pos | Table Pos |
|-----|----------|--------|------------|------------|------------|----------------|------------|---------------|---------|---------|-----------|
| | MHz | dBuV/m | dB | dBuV/m | dBuV | dB/m | dB | dB | | cm | deg |
| 1 # | 2420.580 | 104.05 | | | 72.86 | 28.36 | 2.82 | 0.00 | Peak | --- | --- |
| 1 @ | 2420.580 | 94.19 | | | 63.00 | 28.36 | 2.82 | 0.00 | Average | --- | --- |

An item 1 is fundamental.

Channel 9

| | Freq | Level | Over Limit | Limit Line | Read Level | Antenna Factor | Cable Loss | Preamp Factor | Remark | Ant Pos | Table Pos |
|-----|----------|--------|------------|------------|------------|----------------|------------|---------------|---------|---------|-----------|
| | MHz | dBuV/m | dB | dBuV/m | dBuV | dB/m | dB | dB | | cm | deg |
| 1 # | 2435.780 | 103.37 | | | 72.16 | 28.36 | 2.85 | 0.00 | Peak | --- | --- |
| 2 | 2483.850 | 71.91 | -2.09 | 74.00 | 40.57 | 28.47 | 2.87 | 0.00 | Peak | --- | --- |
| 1 @ | 2440.340 | 94.56 | | | 63.32 | 28.40 | 2.85 | 0.00 | Average | --- | --- |
| 2 | 2483.850 | 51.45 | -2.55 | 54.00 | 20.11 | 28.47 | 2.87 | 0.00 | Average | --- | --- |

An item 1 is fundamental.

Note:

Emission level (dBuV/m) = 20 log Emission level (uV/m).

Corrected Reading: Antenna Factor + Cable Loss + Read Level - Preamp Factor = Level.

For Emission not in Restricted Band

Low Band Edge Plot on Configuration IEEE 802.11n (20MHz) / 2412 MHz

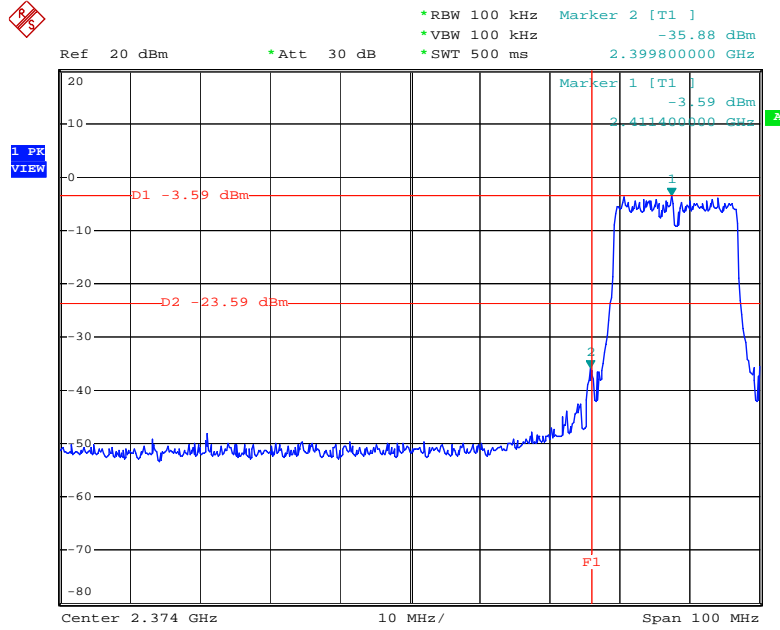

Date: 29.MAY.2007 08:31:11

High Band Edge Plot on Configuration IEEE 802.11n (20MHz) / 2462 MHz

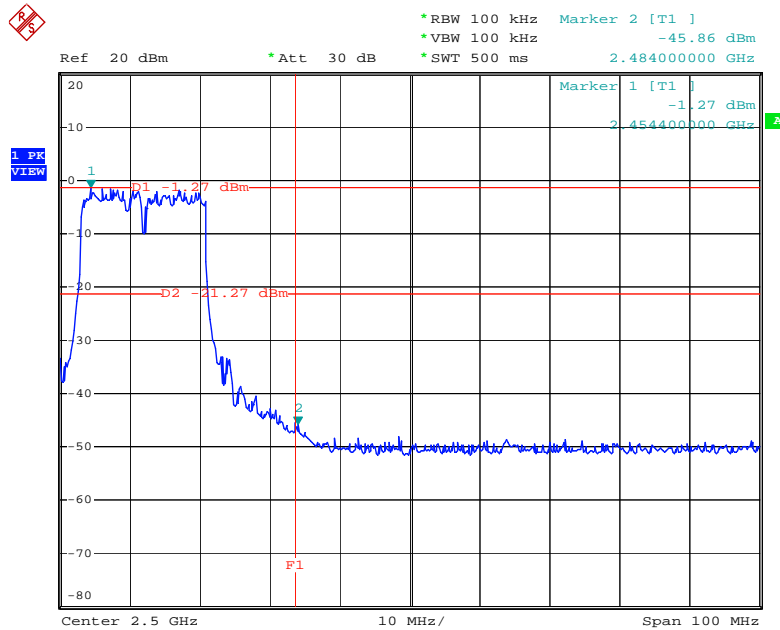

Date: 29.MAY.2007 08:51:45

For Emission not in Restricted Band

Low Band Edge Plot on Configuration IEEE 802.11n (40MHz) / 2422 MHz

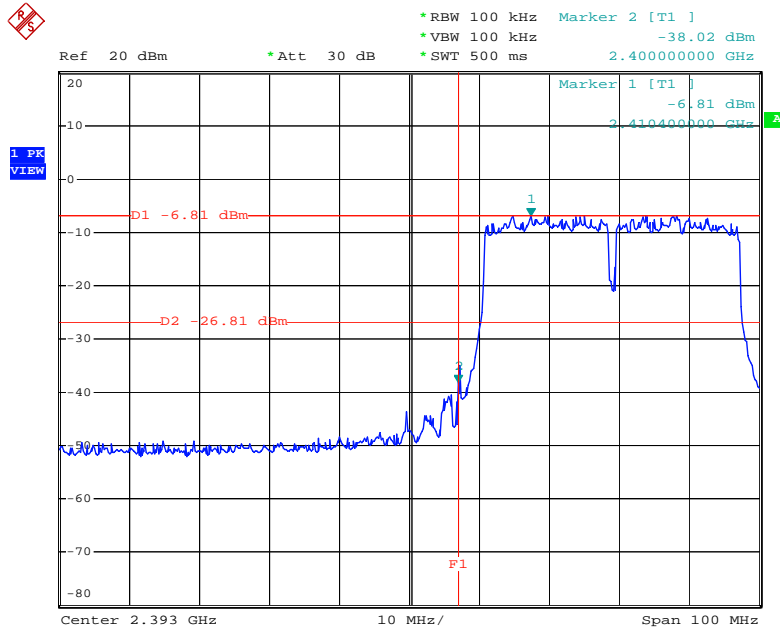

Date: 29.MAY.2007 07:59:12

High Band Edge Plot on Configuration IEEE 802.11n (40MHz) / 2452 MHz

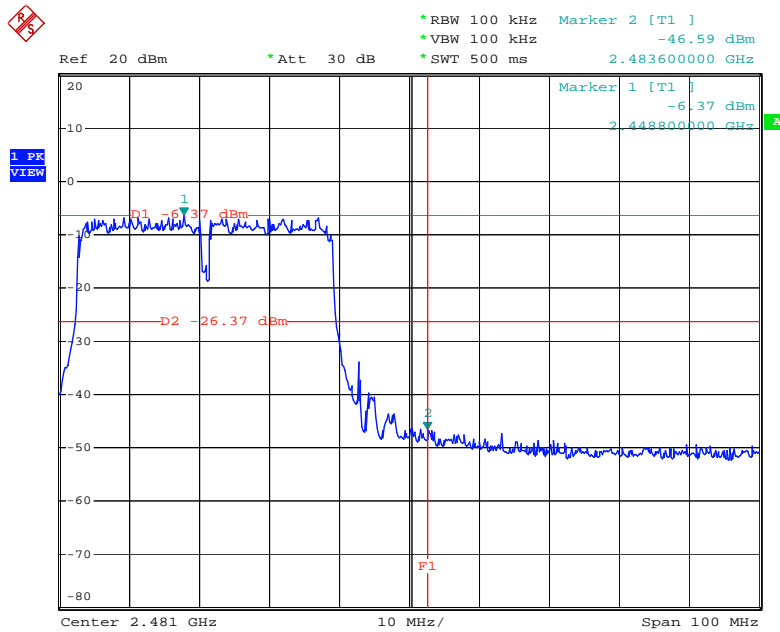

Date: 29.MAY.2007 08:21:46

3.7 Antenna Requirements

3.7.1 Limit

Except for special regulations, the Low-power Radio-frequency Devices must not be equipped with any jacket for installing an antenna with extension cable. An intentional radiator shall be designed to ensure that no antenna other than that furnished by the responsible party shall be used with the device. The use of a permanently attached antenna or of an antenna that uses a unique coupling to the intentional radiator shall be considered sufficient to comply with the provisions of this Section. The manufacturer may design the unit so that the user can replace a broken antenna, but the use of a standard antenna jack or electrical connector is prohibited. Further, this requirement does not apply to intentional radiators that must be professionally installed.

3.7.2 Antenna Connector Construction

Please refer to section 2.2 in this test report; antenna connector complied with the requirements.

4 LIST OF MEASURING EQUIPMENTS

| Instrument | Manufacturer | Model No. | Serial No. | Characteristics | Calibration Date | Remark |
|----------------------------|-------------------|----------------|-------------|----------------------|------------------|-----------------------|
| EMC Receiver | R&S | ESCS 30 | 100359 | 9kHz – 2.75GHz | Mar. 01, 2007 | Conduction (CO04-HY) |
| LISN | MessTec | NNB-2/16Z | 99079 | 9kHz – 30MHz | Mar. 31, 2007 | Conduction (CO04-HY) |
| LISN (Support Unit) | EMCO | 3810/2NM | 9703-1839 | 9kHz – 30MHz | Mar. 22, 2007 | Conduction (CO04-HY) |
| RF Cable-CON | UTIFLEX | 3102-26886-4 | CB049 | 9kHz – 30MHz | Apr. 20, 2007 | Conduction (CO04-HY) |
| EMI Filter | LINDGREN | LRE-2030 | 2651 | < 450 Hz | N/A | Conduction (CO04-HY) |
| Isolation Transformer | Erika Fiedler OHG | D-65396 Walluf | 58 | 45MHz-2.15GHz | N/A | Conduction (CO04-HY) |
| Spectrum Analyzer | R&S | FSP30 | 100023 | 9kHz ~ 30GHz | Dec. 17, 2006 | Conducted (TH01-HY) |
| Power Meter | R&S | NRVS | 100764 | DC ~ 40GHz | Jul. 20, 2006 | Conducted (TH01-HY) |
| Power Sensor | R&S | NRV-Z51 | 100666 | DC ~ 40GHz | Jul. 20, 2006 | Conducted (TH01-HY) |
| Power Sensor | R&S | NRV-Z32 | 100057 | 30MHz ~ 6GHz | Jun. 10, 2006 | Conducted (TH01-HY) |
| DC Power Source | G.W. | GPC-6030D | C671845 | DC 1V ~ 60V | Mar. 03, 2007 | Conducted (TH01-HY) |
| Temp. and Humidity Chamber | KSON | THS-C3L | 612 | N/A | Oct. 02, 2006 | Conducted (TH01-HY) |
| RF CABLE-1m | Jye Bao | RG142 | CB034-1m | 20MHz ~ 7GHz | Dec. 01, 2006 | Conducted (TH01-HY) |
| RF CABLE-2m | Jye Bao | RG142 | CB035-2m | 20MHz ~ 1GHz | Dec. 01, 2006 | Conducted (TH01-HY) |
| Oscilloscope | Tektronix | TDS1012 | CO38515 | 100MHz / 1GS/s | Jun. 20, 2006 | Conducted (TH01-HY) |
| Signal Generator | R&S | SMR40 | 100116 | 10MHz ~ 40GHz | Mar. 07, 2007 | Conducted (TH01-HY) |
| Data Generator | Tektronix | DG2030 | 063-2920-50 | 0.1Hz~400MHz | Jun. 16, 2006 | Conducted (TH01-HY) |
| 3m Semi Anechoic Chamber | SIDT FRANKONIA | SAC-3M | 03CH03-HY | 30 MHz - 1 GHz 3m | Jun. 15, 2006 | Radiation (03CH03-HY) |
| Amplifier | SCHAFFNER | CPA9231A | 1886 | 9 kHz - 2 GHz | Jan. 22, 2007 | Radiation (03CH03-HY) |
| Spectrum Analyzer | R&S | FSP40 | 100004/040 | 9 kHz - 40 GHz | Sep. 21, 2006 | Radiation (03CH03-HY) |
| Bilog Antenna | SCHAFFNER | CBL 6112D | 22237 | 30 MHz – 1 GHz | Jul. 24, 2006 | Radiation (03CH03-HY) |
| Horn Antenna | EMCO | 3115 | 6741 | 1GHz ~ 18GHz | May 04, 2007 | Radiation (03CH03-HY) |
| Horn Antenna | SCHWARZBECK | BBHA9170 | BBHA9170154 | 15 GHz - 40 GHz | NCR | Radiation (03CH03-HY) |
| RF Cable-R03m | Jye Bao | RG142 | CB021 | 30 MHz - 1 GHz | Dec. 02, 2006 | Radiation (03CH03-HY) |
| RF Cable-HIGH | SUHNER | SUCOFLEX 106 | 03CH03-HY | 1 GHz - 40 GHz | Dec. 02, 2006 | Radiation (03CH03-HY) |
| Turn Table | HD | DS 420 | 420/650/00 | 0 – 360 degree | N/A | Radiation (03CH03-HY) |
| Antenna Mast | HD | MA 240 | 240/560/00 | 1 m - 4 m | N/A | Radiation (03CH03-HY) |

Note: Calibration Interval of instruments listed above is one year. NCR: Non-Calibration required.

| Instrument | Manufacturer | Model No. | Serial No. | Characteristics | Calibration Date | Remark |
|-----------------|--------------|---------------|-------------|-------------------|------------------|-----------------------|
| AC Power Source | HPC | HPA-500W | HPA-9100024 | AC 0 ~ 300V | May 04, 2007* | Conducted (TH01-HY) |
| Amplifier | MITEQ | AMF-6F-260400 | 923364 | 26.5 GHz - 40 GHz | Jan. 22, 2007* | Radiation (03CH03-HY) |
| Loop Antenna | R&S | HFH2-Z2 | 860004/001 | 9 kHz - 30 MHz | May 23, 2006* | Radiation (03CH03-HY) |

Note: Calibration Interval of instruments listed above is two year.

5 TEST LOCATION

| | |
|--------|--|
| SHIJR | ADD : 6Fl., No. 106, Sec. 1, Shintai 5th Rd., Shijr City, Taipei, Taiwan 221, R.O.C. TEL : 886-2-2696-2468 FAX : 886-2-2696-2255 |
| HWA YA | ADD : No. 52, Hwa Ya 1st Rd., Kwei-Shan Hsiang, Tao Yuan Hsien, Taiwan, R.O.C. TEL : 886-3-327-3456 FAX : 886-3-318-0055 |
| LINKOU | ADD : No. 30-2, Dingfu Tsuen, Linkou Shiang, Taipei, Taiwan 244, R.O.C TEL : 886-2-2601-1640 FAX : 886-2-2601-1695 |
| DUNGHU | ADD : No. 3, Lane 238, Kangle St., Neihu Chiu, Taipei, Taiwan 114, R.O.C. TEL : 886-2-2631-4739 FAX : 886-2-2631-9740 |
| JUNGHE | ADD : 7Fl., No. 758, Jungjeng Rd., Junghe City, Taipei, Taiwan 235, R.O.C. TEL : 886-2-8227-2020 FAX : 886-2-8227-2626 |
| NEIHU | ADD : 4Fl., No. 339, Hsin Hu 2 nd Rd., Taipei 114, Taiwan, R.O.C. TEL : 886-2-2794-8886 FAX : 886-2-2794-9777 |
| JHUBEI | ADD : No.8, Lane 728, Bo-ai St., Jhubei City, HsinChu County 302, Taiwan, R.O.C. TEL : 886-3-656-9065 FAX : 886-3-656-9085 |

6 TAF CERTIFICATE OF ACCREDITATION



Certificate No. : L1190-070110

財團法人全國認證基金會
Taiwan Accreditation Foundation

Certificate of Accreditation

This is to certify that

Sporton International Inc.

EMC & Wireless Communications Laboratory

No.52, Hwa Ya 1st Rd., Hwa Ya Technology Park, Kwei-Shan Hsiang, Tao Yuan Hsien,
Taiwan, R.O.C.

is accredited in respect of laboratory

- Accreditation Criteria : ISO/IEC 17025:2005
- Accreditation Number : 1190
- Originally Accredited : December 15, 2003
- Effective Period : January 10, 2007 to January 09, 2010
- Accredited Scope : Testing Field, see described in the Appendix
Accreditation Program for Designated Testing Laboratory
- Specific Accreditation Program : for Commodities Inspection
Accreditation Program for Telecommunication Equipment Testing Laboratory

Jay-San Chen
President, Taiwan Accreditation Foundation
Date : January 10, 2007

PI, total 9 pages

The Appendix forms an integral part of this Certificate, which shall be invalid when used without the Appendix.