



FCC TEST REPORT (15.407)

REPORT NO.: RF961003L09-1

MODEL NO.: WMIA-139AG

RECEIVED: Oct. 22, 2007

TESTED: Oct. 24 ~ Oct. 31, 2007

ISSUED: Nov. 02, 2007

APPLICANT: SparkLAN Communications, Inc.

ADDRESS: 3Fl., No. 246, Sec. 1, Neihu Road., Neihu
Chiu, Taipei Taiwan 114, R.O.C

ISSUED BY: Advance Data Technology Corporation

LAB ADDRESS: No. 47, 14th Ling, Chia Pau Tsuen, Lin Kou
Hsiang 244, Taipei Hsien, Taiwan, R.O.C.

TEST LOCATION: No. 19, Hwa Ya 2nd Rd., Kwei Shan Hsiang,
Taoyuan Hsien 333, Taiwan, R.O.C.

This test report consists of 65 pages in total. It may be duplicated completely for legal use with the approval of the applicant. It should not be reproduced except in full, without the written approval of our laboratory. The client should not use it to claim product endorsement by TAF, A2LA or any government agencies. The test results in the report only apply to the tested sample.





TABLE OF CONTENTS

1.	CERTIFICATION	4
2.	SUMMARY OF TEST RESULTS.....	5
2.1	MEASUREMENT UNCERTAINTY	5
3.	GENERAL INFORMATION	6
3.1	GENERAL DESCRIPTION OF EUT	6
3.2	DESCRIPTION OF TEST MODES	7
3.2.1	CONFIGURATION OF SYSTEM UNDER TEST.....	8
3.2.2	TEST MODE APPLICABILITY AND TESTED CHANNEL DETAIL	9
3.3	GENERAL DESCRIPTION OF APPLIED STANDARDS.....	11
3.4	DESCRIPTION OF SUPPORT UNITS.....	11
4.	TEST TYPES AND RESULTS.....	12
4.1	RADIATED EMISSION MEASUREMENT	12
4.1.1	LIMITS OF RADIATED EMISSION MEASUREMENT	12
4.1.2	LIMITS OF UNWANTED EMISSION OUT OF THE RESTRICTED BANDS	12
4.1.3	TEST INSTRUMENTS	13
4.1.4	TEST PROCEDURES.....	14
4.1.5	DEVIATION FROM TEST STANDARD	14
4.1.6	TEST SETUP	15
4.1.7	EUT OPERATING CONDITION	15
4.1.8	TEST RESULTS.....	16
4.2	CONDUCTED EMISSION MEASUREMENT.....	26
4.2.1	LIMITS OF CONDUCTED EMISSION MEASUREMENT	26
4.2.2	TEST INSTRUMENTS	26
4.2.3	TEST PROCEDURES.....	27
4.2.4	DEVIATION FROM TEST STANDARD	27
4.2.5	TEST SETUP	28
4.2.6	EUT OPERATING CONDITIONS.....	28
4.2.7	TEST RESULTS.....	29
4.3	PEAK TRANSMIT POWER MEASUREMENT.....	31
4.3.1	LIMITS OF PEAK TRANSMIT POWER MEASUREMENT	31
4.3.2	TEST INSTRUMENTS	31
4.3.3	TEST PROCEDURE	31
4.3.4	DEVIATION FROM TEST STANDARD	32
4.3.5	TEST SETUP	32
4.3.6	EUT OPERATING CONDITIONS.....	32
4.3.7	TEST RESULTS.....	33
4.4	PEAK POWER EXCURSION MEASUREMENT.....	39
4.4.1	LIMITS OF PEAK POWER EXCURSION MEASUREMENT	39
4.4.2	TEST INSTRUMENTS	39
4.4.3	TEST PROCEDURE	39
4.4.4	DEVIATION FROM TEST STANDARD	40
4.4.5	TEST SETUP	40
4.4.6	EUT OPERATING CONDITIONS.....	40
4.4.7	TEST RESULTS.....	41
4.5	PEAK POWER SPECTRAL DENSITY MEASUREMENT.....	44
4.5.1	LIMITS OF PEAK POWER SPECTRAL DENSITY MEASUREMENT	44
4.5.2	TEST INSTRUMENTS	44
4.5.3	TEST PROCEDURES.....	44



4.5.4	DEVIATION FROM TEST STANDARD	44
4.5.5	TEST SETUP	45
4.5.6	EUT OPERATING CONDITIONS.....	45
4.5.7	TEST RESULTS.....	46
4.6	FREQUENCY STABILITY	49
4.6.1	LIMITS OF FREQUENCY STABILITY MEASUREMENT	49
4.6.2	TEST INSTRUMENTS	49
4.6.3	TEST PROCEDURE	49
4.6.4	DEVIATION FROM TEST STANDARD.....	50
4.6.5	TEST SETUP	50
4.6.6	EUT OPERATING CONDITION	50
4.6.7	TEST RESULTS.....	51
4.7	BAND EDGES MEASUREMENT	52
4.7.1	TEST INSTRUMENTS	52
4.7.2	TEST PROCEDURE	52
4.7.3	EUT OPERATING CONDITION	53
4.7.4	TEST RESULTS.....	53
4.8	ANTENNA REQUIREMENT.....	62
4.8.1	STANDARD APPLICABLE.....	62
4.8.2	ANTENNA CONNECTED CONSTRUCTION	62
5.	PHOTOGRAPHS OF THE TEST CONFIGURATION	63
6.	INFORMATION ON THE TESTING LABORATORIES.....	64
7.	APPENDIX A - MODIFICATIONS RECORDERS FOR ENGINEERING CHANGES TO THE EUT BY THE LAB	65



1. CERTIFICATION

PRODUCT: Wireless 802.11a/b/g Mini PCI module

MODEL: WMIA-139AG

BRAND: SparkLAN

APPLICANT: SparkLAN Communications, Inc.

TEST SAMPLE: ENGINEERING SAMPLE

TESTED: Oct. 24 ~ Oct. 31, 2007

STANDARDS: FCC Part 15, Subpart E (Section 15.407)

ANSI C63.4-2003

The above equipment (Model: WMIA-139AG) has been tested by **Advance Data Technology Corporation**, and found compliance with the requirement of the above standards. The test record, data evaluation & Equipment Under Test (EUT) configurations represented herein are true and accurate accounts of the measurements of the sample's EMC characteristics under the conditions specified in this report.

PREPARED BY : Andrea Hsia , **DATE:** Nov. 02, 2007
Andrea Hsia / Specialist

TECHNICAL ACCEPTANCE : Long Chen , **DATE:** Nov. 02, 2007
Responsible for RF Long Chen / Senior Engineer

APPROVED BY : Gary Chang , **DATE:** Nov. 02, 2007
Gary Chang / Assistant Manager

2. SUMMARY OF TEST RESULTS

The EUT has been tested according to the following specifications:

APPLIED STANDARD: FCC PART 15, SUBPART E (SECTION 15.407)			
STANDARD SECTION	TEST TYPE AND LIMIT	RESULT	REMARK
15.407(b)(5)	AC Power Conducted Emission	PASS	Meet the requirement of limit. Minimum passing margin is -14.91dB at 0.154MHz.
15.407(b)(1/2/3) (b)(5)	Electric Field Strength Spurious Emissions, 30MHz ~ 40000MHz	PASS	Meet the requirement of limit. Minimum passing margin is -1.11dB at 5150.00MHz.
15.407(a)(1/2/3)	Peak Transmit Power	PASS	Meet the requirement of limit.
15.407(a)(6)	Peak Power Excursion	PASS	Meet the requirement of limit.
15.407(a)(1/2/3)	Peak Power Spectral Density	PASS	Meet the requirement of limit.
15.407(g)	Frequency Stability	PASS	Meet the requirement of limit.

2.1 MEASUREMENT UNCERTAINTY

Where relevant, the following measurement uncertainty levels have been estimated for tests performed on the EUT as specified in CISPR 16-4-2:

MEASUREMENT	FREQUENCY	UNCERTAINTY
Conducted emissions	9kHz~30MHz	2.44 dB
Radiated emissions	30MHz ~ 200MHz	2.93 dB
	200MHz ~1000MHz	2.95 dB
	1GHz ~ 18GHz	2.26 dB
	18GHz ~ 40GHz	1.94 dB

This uncertainty represents an expanded uncertainty expressed at approximately the 95% confidence level using a coverage factor of $k = 2$.

3. GENERAL INFORMATION

3.1 GENERAL DESCRIPTION OF EUT

EUT	Wireless 802.11a/b/g Mini PCI module
MODEL NO.	WMIA-139AG
FCC ID	RYK-WMIA139AGX
POWER SUPPLY	3.3Vdc or 5.0Vdc from DC power supply
MODULATION TYPE	CCK, DQPSK, DBPSK for DSSS 64QAM, 16QAM, QPSK, BPSK for OFDM
MODULATION TECHNOLOGY	DSSS, OFDM
TRANSFER RATE	802.11b:11/5.5/2/1Mbps 802.11g: 54/48/36/24/18/12/9/6Mbps 802.11a: 54/48/36/24/18/12/9/6Mbps (Turbo mode: up to 108Mbps *see Note 3)
FREQUENCY RANGE	2.4GHz: 2400 ~ 2483.5MHz 5.0GHz: 5150 ~ 5250MHz, 5725 ~ 5850MHz
NUMBER OF CHANNEL	2.4GHz: 11 for Normal mode / 1 for Turbo mode 5.0GHz: 5150 ~ 5250MHz: 4 for 802.11a / 1 for Turbo mode 5725 ~ 5850MHz: 5 for 802.11a / 2 for Turbo mode
OUTPUT POWER	35.810mW for 2400 ~ 2483.5MHz 28.907mW for 5150 ~ 5250MHz 51.050mW for 5725 ~ 5850MHz
ANTENNA TYPE	Refer to note as below
DATA CABLE	NA
I/O PORTS	NA
ASSOCIATED DEVICES	NA

NOTE:

- The following antennas are used in this EUT.

ITEM	TEST MDOE	ANTENNA MODEL	ANTENNA TYPE	GAIN(dBi)		CONNECTER
				2.4GHz	5.0GHz	
1	A	EA-292B-1	Dipole	-	4.15	Reverse SMA
2	B	EA-292B	Dipole	-	4.56	Reverse SMA
3	C	HAO9SDP	Hi-Gain Outdoor Directional	9.0	-	N Jack
4	D	HG2409UM	Omnidirectional Wireless LAN Marine	8.5	-	RP-SMA plug
5	E	HGA51G-DIR30	TIKI (Printed Antenna)	-	8.00	RP SMA Plug

**For Antenna item 1 & 2, chosen the one with higher gain for final test and presented in the test report.

- The EUT operates in both the 5GHz and 2.4GHz Bands and compatibility with 802.11a and 802.11b, 802.11g technology.
- This EUT is capable of providing data rates of up to 108 Mbps in Turbo mode depending upon reception quality.
- The above EUT information was declared by manufacturer and for more detailed features description, please refer to the manufacturer's specifications or user's manual.

3.2 DESCRIPTION OF TEST MODES

Operated in 5150 ~ 5250MHz

4 channels are provided for 802.11a:

CHANNEL	FREQUENCY
1	5180 MHz
2	5200 MHz
3	5220 MHz
4	5240 MHz

1 channel is provided for turbo mode.

CHANNEL	FREQUENCY
1	5210 MHz

3.2.1 CONFIGURATION OF SYSTEM UNDER TEST

TEST MODE A,B & E

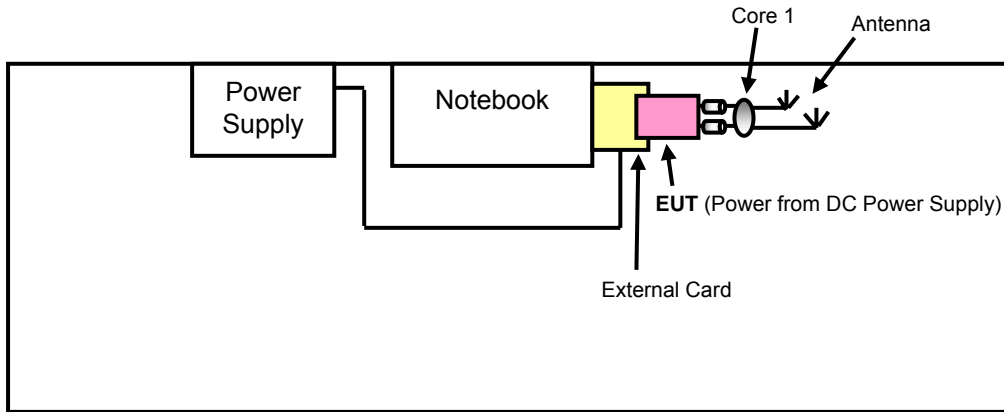

TEST MODE C

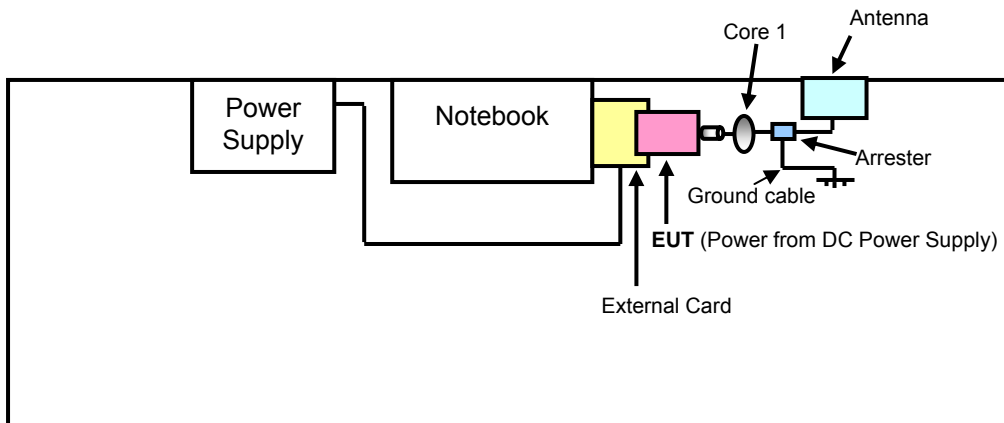

TEST MODE D

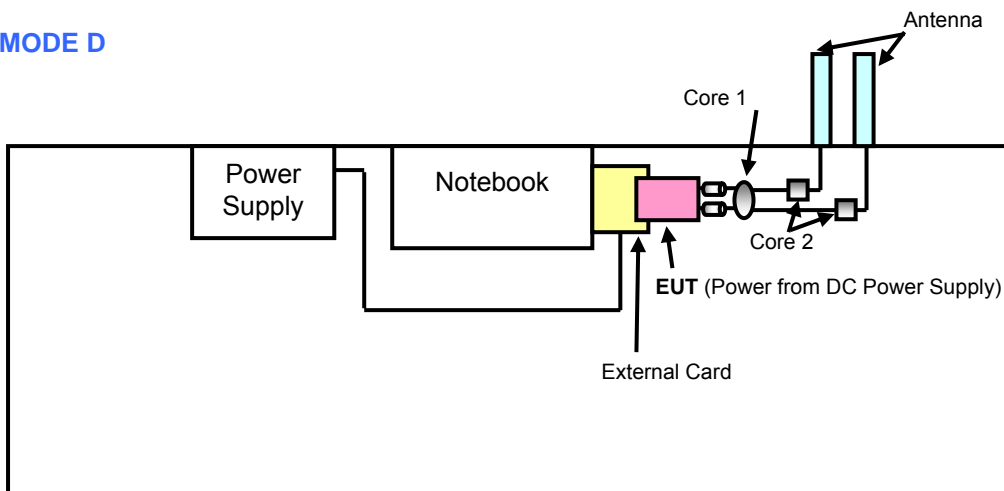

3.2.2 TEST MODE APPLICABILITY AND TESTED CHANNEL DETAIL

EUT CONFIGURE MODE	APPLICABLE TO				DESCRIPTION
	RE<1G	RE≥1G	PLC	APCM	
B	√	√	-	-	For Antenna item 2
E	√	√	√	√	For Antenna item 5

Where **PLC**: Power Line Conducted Emission **RE<1G**: Radiated Emission below 1GHz
RE≥1G: Radiated Emission above 1GHz **APCM**: Antenna Port Conducted Measurement

RADIATED EMISSION TEST (ABOVE 1GHz):

- Pre-Scan has been conducted to determine the worst-case mode from all possible combinations between available modulations, data rates and antenna ports (if EUT with antenna diversity architecture).
- Following channel(s) was (were) selected for the final test as listed below.

EUT CONFIGURE MODE	MODE	AVAILABLE CHANNEL	TESTED CHANNEL	MODULATION TECHNOLOGY	MODULATION TYPE	DATA RATE (Mbps)
B	802.11a	1 to 4	1, 2, 4	OFDM	BPSK	6
B	802.11a Turbo	1	1	OFDM	QPSK	12
E	802.11a	1 to 4	1, 2, 4	OFDM	BPSK	6
E	802.11a Turbo	1	1	OFDM	QPSK	12

RADIATED EMISSION TEST (BELOW 1GHz):

- Pre-Scan has been conducted to determine the worst-case mode from all possible combinations between available modulations, data rates and antenna ports (if EUT with antenna diversity architecture).
- Following channel(s) was (were) selected for the final test as listed below.

EUT CONFIGURE MODE	MODE	AVAILABLE CHANNEL	TESTED CHANNEL	MODULATION TECHNOLOGY	MODULATION TYPE	DATA RATE (Mbps)
B	802.11a	1 to 4	2	OFDM	BPSK	6
E	802.11a	1 to 4	2	OFDM	BPSK	6

POWER LINE CONDUCTED EMISSION TEST:

- Pre-Scan has been conducted to determine the worst-case mode from all possible combinations between available modulations, data rates and antenna ports (if EUT with antenna diversity architecture).
- Following channel(s) was (were) selected for the final test as listed below.

EUT CONFIGURE MODE	MODE	AVAILABLE CHANNEL	TESTED CHANNEL	MODULATION TECHNOLOGY	MODULATION TYPE	DATA RATE (Mbps)
E	802.11a	1 to 4	2	OFDM	BPSK	6

BANDEDGE MEASUREMENT:

- Pre-Scan has been conducted to determine the worst-case mode from all possible combinations between available modulations, data rates and antenna ports (if EUT with antenna diversity architecture).
- Following channel(s) was (were) selected for the final test as listed below.

EUT CONFIGURE MODE	MODE	AVAILABLE CHANNEL	TESTED CHANNEL	MODULATION TECHNOLOGY	MODULATION TYPE	DATA RATE (Mbps)
B	802.11a	1 to 4	1, 4	OFDM	BPSK	6
B	802.11a Turbo	1	1	OFDM	QPSK	12
E	802.11a	1 to 4	1, 4	OFDM	BPSK	6
E	802.11a Turbo	1	1	OFDM	QPSK	12

ANTENNA PORT CONDUCTED MEASUREMENT:

- Pre-Scan has been conducted to determine the worst-case mode from all possible combinations between available modulations, data rates and antenna ports (if EUT with antenna diversity architecture).
- Following channel(s) was (were) selected for the final test as listed below.

EUT CONFIGURE MODE	MODE	AVAILABLE CHANNEL	TESTED CHANNEL	MODULATION TECHNOLOGY	MODULATION TYPE	DATA RATE (Mbps)
E	802.11a	1 to 4	1, 2, 4	OFDM	BPSK	6
E	802.11a Turbo	1	1	OFDM	QPSK	12



3.3 GENERAL DESCRIPTION OF APPLIED STANDARDS

The EUT is a RF Product. According to the specifications of the manufacturer, it must comply with the requirements of the following standards:

FCC Part 15, Subpart E (15.407)

ANSI C63.4-2003

All test items have been performed and recorded as per the above standards.

NOTE: The EUT is also considered as a kind of computer peripheral, because the connection to computer is necessary for typical use. It has been verified to comply with the requirements of FCC Part 15, Subpart B, Class B (DoC). The test report has been issued separately.

3.4 DESCRIPTION OF SUPPORT UNITS

The EUT has been tested as an independent unit together with other necessary accessories or support units. The following support units or accessories were used to form a representative test configuration during the tests.

NO.	PRODUCT	BRAND	MODEL NO.	SERIAL NO.	FCC ID
1	NOTEBOOK COMPUTER	DELL	PP05L	9954115984	E2K24CLNS
2	POWER SUPPLY	TOP WARD	6603A	725906	NA
3	CORE 1	kingcore	KCF-50-B	NA	NA
4	CORE 2	kingcore	KCF-130-B	NA	NA

NO.	SIGNAL CABLE DESCRIPTION OF THE ABOVE SUPPORT UNITS
1	NA
2	1.7m shielded without core
3	NA
4	NA

NOTE: All power cords of the above support units are non shielded (1.8m).

4. TEST TYPES AND RESULTS

4.1 RADIATED EMISSION MEASUREMENT

4.1.1 LIMITS OF RADIATED EMISSION MEASUREMENT

Emissions radiated outside of the specified bands, shall be according to the general radiated limits in 15.209 as following:

FREQUENCIES (MHz)	FIELD STRENGTH (microvolts/meter)	MEASUREMENT DISTANCE (meters)
0.009 ~ 0.490	2400/F(kHz)	300
0.490 ~ 1.705	24000/F(kHz)	30
1.705 ~ 30.0	30	30
30 ~ 88	100	3
88 ~ 216	150	3
216 ~ 960	200	3
Above 960	500	3

NOTE:

1. The lower limit shall apply at the transition frequencies.
2. Emission level (dBuV/m) = 20 log Emission level (uV/m).
3. As shown in 15.35(b), for frequencies above 1000MHz, the field strength limits are based on average detector, however, the peak field strength of any emission shall not exceed the maximum permitted average limits, specified above by more than 20dB under any condition of modulation.

4.1.2 LIMITS OF UNWANTED EMISSION OUT OF THE RESTRICTED BANDS

FREQUENCIES (MHz)	EIRP LIMIT (dBm)		EQUIVALENT FIELD STRENGTH AT 3m (dBμV/m) *NOTE 3	
	PK	AV	PK	AV
5150 ~ 5250	-7	-27	88.3	68.3
5250 ~ 5350	-7	-27	88.3	68.3
5470 ~ 5725	-7	-27	88.3	68.3

NOTE:

1. For frequencies 10MHz or greater above or below the band edge.
2. All emissions within the frequency range from the band edge to 10MHz above or below the band edge.
3. The following formula is used to convert the equipment isotropic radiated power (eirp) to field strength:

$$E = \frac{1000000\sqrt{30P}}{3} \mu\text{V/m, where P is the eirp (Watts).}$$



4.1.3 TEST INSTRUMENTS

DESCRIPTION & MANUFACTURER	MODEL NO.	SERIAL NO.	CALIBRATED UNTIL
Test Receiver ROHDE & SCHWARZ	ESCI	100424	Jul. 27, 2008
Spectrum Analyzer ROHDE & SCHWARZ	FSP40	100269	Aug. 05, 2008
BILOG Antenna SCHWARZBECK	VULB9168	9168-153	Jan. 04, 2008
HORN Antenna SCHWARZBECK	BBHA 9120 D	9120D-563	Jul. 30, 2008
HORN Antenna SCHWARZBECK	BBHA 9170	BBHA9170242	Jan. 16, 2008
Preamplifier Agilent	8449B	3008A01910	Sep. 19, 2008
Preamplifier Agilent	8447D	2944A10638	Dec. 20, 2007
RF signal cable HUBER+SUHNNER	SUCOFLEX 104	218188/218189	Nov. 14, 2007
RF signal cable Worken	8D-FB	Cable-HYCH9-01	Aug. 09, 2008
Software	ADT_Radiated_V7.6	NA	NA
Antenna Tower EMCO	2070/2080	512.835.4684	NA
Turn Table EMCO	2087-2.03	NA	NA
Antenna Tower & Turn Table Controller EMCO	2090	NA	NA
26GHz ~ 40GHz Amplifier	EM26400	07026401	Apr. 23, 2008

- NOTE:**
1. The calibration interval of the above test instruments is 12 months and the calibrations are traceable to NML/ROC and NIST/USA.
 2. The test was performed in HwaYa Chamber 9.
 3. The horn antenna and HP preamplifier (model: 8449B) are used only for the measurement of emission frequency above 1GHz if tested.
 4. The IC Site Registration No. is IC3789B-9.

4.1.4 TEST PROCEDURES

- a. The EUT was placed on the top of a rotating table 0.8 meters above the ground at a 3 meter semi-anechoic chamber. The table was rotated 360 degrees to determine the position of the highest radiation.
- b. The EUT was set 3 meters away from the interference-receiving antenna, which was mounted on the top of a variable-height antenna tower.
- c. The antenna is a broadband antenna, and its height is varied from one meter to four meters above the ground to determine the maximum value of the field strength. Both horizontal and vertical polarizations of the antenna are set to make the measurement.
- d. For each suspected emission, the EUT was arranged to its worst case and then the antenna was tuned to heights from 1 meter to 4 meters and the rotatable table was turned from 0 degrees to 360 degrees to find the maximum reading.
- e. The test-receiver system was set to Peak Detect Function and Specified Bandwidth with Maximum Hold Mode.
- f. If the emission level of the EUT in peak mode was 10dB lower than the limit specified, then testing could be stopped and the peak values of the EUT would be reported. Otherwise the emissions that did not have 10dB margin would be re-tested one by one using peak, quasi-peak or average method as specified and then reported in a data sheet.

NOTE:

1. The resolution bandwidth and video bandwidth of test receiver/spectrum analyzer is 120kHz for Peak detection (PK) and Quasi-peak detection (QP) at frequency below 1GHz.
2. The resolution bandwidth of test receiver/spectrum analyzer is 1MHz and video bandwidth is 3MHz for Peak detection at frequency above 1GHz.
3. The resolution bandwidth of test receiver/spectrum analyzer is 1 MHz and the video bandwidth is 10Hz for Average detection (AV) at frequency above 1GHz.
4. All modes of operation were investigated and the worst-case emissions are reported.

4.1.5 DEVIATION FROM TEST STANDARD

No deviation

4.1.6 TEST SETUP

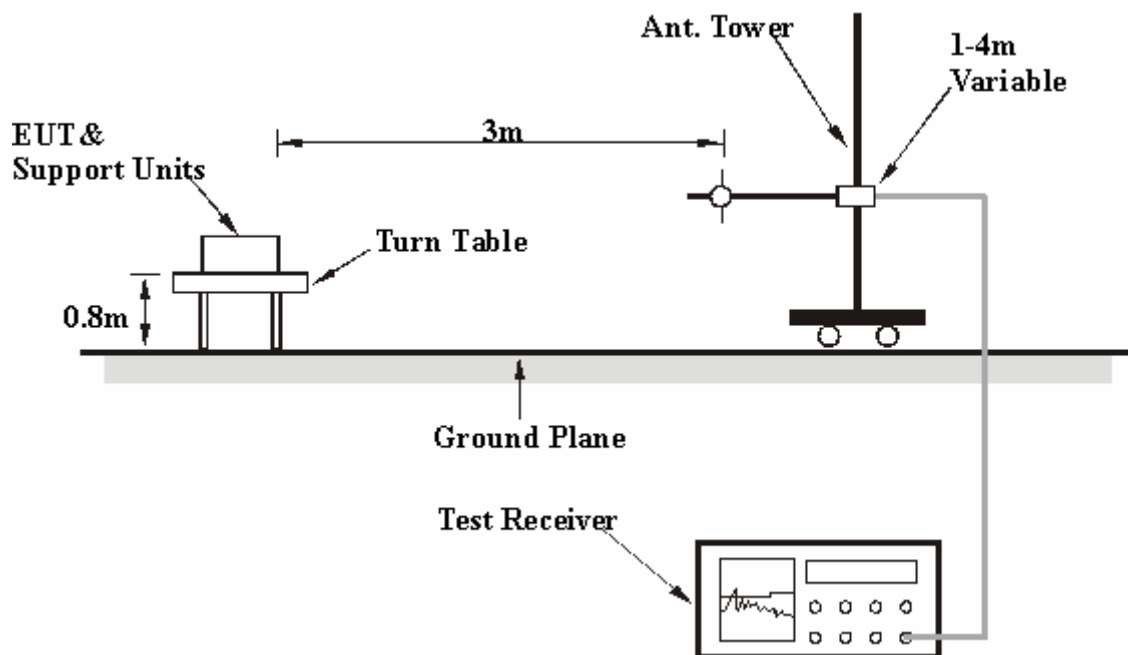

For the actual test configuration, please refer to the attached file (Test Setup Photo).

4.1.7 EUT OPERATING CONDITION

- Connected the EUT into the notebook system via external card and placed on a testing table.
- The EUT ran a test program (provided by manufacturer) to enable all functions under transmission condition continuously at specific channel frequency.
- The necessary accessories enable the EUT in full functions.

4.1.8 TEST RESULTS

ABOVE 1GHz DATA: 802.11a OFDM MODULATION_NORMAL MODE:

EUT TEST CONDITION		MEASUREMENT DETAIL	
CHANNEL	Channel 1	FREQUENCY RANGE	1 ~ 40GHz
MODULATION TYPE	BPSK	DETECTOR FUNCTION	Peak (PK) Average (AV)
INPUT POWER (SYSTEM)	120Vac, 60Hz	ENVIRONMENTAL CONDITIONS	25deg. C, 65%RH, 991hPa
TEST MODE	B	TESTED BY	Long Chen

ANTENNA POLARITY & TEST DISTANCE: HORIZONTAL AT 3 M								
No.	Freq. (MHz)	Emission Level (dBuV/m)	Limit (dBuV/m)	Margin (dB)	Antenna Height (m)	Table Angle (Degree)	Raw Value (dBuV)	Correction Factor (dB/m)
1	5150.00	56.26 PK	74.00	-17.74	1.00 H	64	17.89	38.37
2	5150.00	38.91 AV	54.00	-15.09	1.00 H	64	0.54	38.37
3	*5180.00	101.82 PK			1.00 H	64	63.40	38.42
4	*5180.00	90.67 AV			1.00 H	64	52.25	38.42
5	6906.00	52.16 PK	88.30	-36.14	1.07 H	63	8.80	43.36
6	6906.00	40.11 AV	68.30	-28.19	1.07 H	63	-3.25	43.36
7	10360.00	63.88 PK	88.30	-24.42	1.47 H	63	15.13	48.75
8	10360.00	50.68 AV	68.30	-17.62	1.47 H	63	1.93	48.75

ANTENNA POLARITY & TEST DISTANCE: VERTICAL AT 3 M								
No.	Freq. (MHz)	Emission Level (dBuV/m)	Limit (dBuV/m)	Margin (dB)	Antenna Height (m)	Table Angle (Degree)	Raw Value (dBuV)	Correction Factor (dB/m)
1	5150.00	65.15 PK	74.00	-8.85	1.00 V	185	26.78	38.37
2	5150.00	47.82 AV	54.00	-6.18	1.00 V	185	9.45	38.37
3	*5180.00	110.71 PK			1.02 V	224	72.29	38.42
4	*5180.00	99.58 AV			1.02 V	224	61.16	38.42
5	6906.00	53.17 PK	88.30	-35.13	1.15 V	36	9.82	43.36
6	6906.00	41.51 AV	68.30	-26.79	1.15 V	36	-1.84	43.36
7	10360.00	61.23 PK	88.30	-27.07	1.54 V	63	12.48	48.75
8	10360.00	48.23 AV	68.30	-20.07	1.54 V	63	-0.52	48.75

- REMARKS:**
1. Emission level (dBuV/m) = Raw Value (dBuV) + Correction Factor (dB/m).
 2. Correction Factor (dB/m) = Antenna Factor (dB/m) + Cable Factor (dB).
 3. The other emission levels were very low against the limit.
 4. Margin value = Emission level – Limit value.
 5. “ * “: Fundamental frequency.
 6. “ # “: The radiated frequency falling in the restricted band.

EUT TEST CONDITION		MEASUREMENT DETAIL	
CHANNEL	Channel 2	FREQUENCY RANGE	1 ~ 40GHz
MODULATION TYPE	BPSK	DETECTOR FUNCTION	Peak (PK) Average (AV)
INPUT POWER (SYSTEM)	120Vac, 60Hz	ENVIRONMENTAL CONDITIONS	25deg. C, 65%RH, 991hPa
TEST MODE	B	TESTED BY	Long Chen

ANTENNA POLARITY & TEST DISTANCE: HORIZONTAL AT 3 M								
No.	Freq. (MHz)	Emission Level (dBuV/m)	Limit (dBuV/m)	Margin (dB)	Antenna Height (m)	Table Angle (Degree)	Raw Value (dBuV)	Correction Factor (dB/m)
1	*5200.00	103.48 PK			1.00 H	185	65.03	38.45
2	*5200.00	92.26 AV			1.00 H	185	53.81	38.45
3	6933.00	53.49 PK	88.30	-34.81	1.58 H	69	10.06	43.43
4	6933.00	44.17 AV	68.30	-24.13	1.58 H	69	0.74	43.43
5	10400.00	65.81 PK	88.30	-22.49	1.02 H	68	16.98	48.83
6	10400.00	51.02 AV	68.30	-17.28	1.02 H	68	2.19	48.83

ANTENNA POLARITY & TEST DISTANCE: VERTICAL AT 3 M								
No.	Freq. (MHz)	Emission Level (dBuV/m)	Limit (dBuV/m)	Margin (dB)	Antenna Height (m)	Table Angle (Degree)	Raw Value (dBuV)	Correction Factor (dB/m)
1	*5200.00	112.31 PK			1.05 V	233	73.86	38.45
2	*5200.00	101.12 AV			1.05 V	233	62.67	38.45
3	6933.00	49.23 PK	88.30	-39.07	1.46 V	88	5.80	43.43
4	6933.00	40.82 AV	68.30	-27.48	1.46 V	88	-2.61	43.43
5	10400.00	60.53 PK	88.30	-27.77	1.02 V	36	11.70	48.83
6	10400.00	46.80 AV	68.30	-21.50	1.02 V	36	-2.03	48.83

- REMARKS:**
1. Emission level (dBuV/m) = Raw Value (dBuV) + Correction Factor (dB/m).
 2. Correction Factor (dB/m) = Antenna Factor (dB/m) + Cable Factor (dB).
 3. The other emission levels were very low against the limit.
 4. Margin value = Emission level – Limit value.
 5. “ * “: Fundamental frequency.
 6. “ # “: The radiated frequency falling in the restricted band.

EUT TEST CONDITION		MEASUREMENT DETAIL	
CHANNEL	Channel 4	FREQUENCY RANGE	1 ~ 40GHz
MODULATION TYPE	BPSK	DETECTOR FUNCTION	Peak (PK) Average (AV)
INPUT POWER (SYSTEM)	120Vac, 60Hz	ENVIRONMENTAL CONDITIONS	25deg. C, 65%RH, 991hPa
TEST MODE	B	TESTED BY	Long Chen

ANTENNA POLARITY & TEST DISTANCE: HORIZONTAL AT 3 M								
No.	Freq. (MHz)	Emission Level (dBuV/m)	Limit (dBuV/m)	Margin (dB)	Antenna Height (m)	Table Angle (Degree)	Raw Value (dBuV)	Correction Factor (dB/m)
1	*5240.00	102.99 PK			1.03 H	183	64.48	38.51
2	*5240.00	91.84 AV			1.03 H	183	53.33	38.51
3	#5350.00	48.78 PK	74.00	-25.22	1.03 H	183	10.12	38.66
4	#5350.00	36.08 AV	54.00	-17.92	1.03 H	183	-2.59	38.66
5	6987.00	53.22 PK	88.30	-35.08	1.63 H	54	9.65	43.57
6	6987.00	40.21 AV	68.30	-28.09	1.63 H	54	-3.36	43.57
7	10480.00	63.54 PK	88.30	-24.76	1.02 H	69	14.43	49.11
8	10480.00	51.02 AV	68.30	-17.28	1.02 H	69	1.91	49.11

ANTENNA POLARITY & TEST DISTANCE: VERTICAL AT 3 M								
No.	Freq. (MHz)	Emission Level (dBuV/m)	Limit (dBuV/m)	Margin (dB)	Antenna Height (m)	Table Angle (Degree)	Raw Value (dBuV)	Correction Factor (dB/m)
1	*5240.00	111.93 PK			1.03 V	231	73.42	38.51
2	*5240.00	100.99 AV			1.03 V	231	62.48	38.51
3	5350.00	57.72 PK	74.00	-16.28	1.00 V	231	19.05	38.66
4	5350.00	45.23 AV	54.00	-8.77	1.00 V	231	6.57	38.66
5	6987.00	49.85 PK	88.30	-38.45	1.47 V	69	6.28	43.57
6	6987.00	37.22 AV	68.30	-31.08	1.47 V	69	-6.35	43.57
7	10480.00	60.20 PK	88.30	-28.10	1.02 V	68	11.09	49.11
8	10480.00	48.30 AV	68.30	-20.00	1.02 V	68	-0.81	49.11

- REMARKS:**
1. Emission level (dBuV/m) = Raw Value (dBuV) + Correction Factor (dB/m).
 2. Correction Factor (dB/m) = Antenna Factor (dB/m) + Cable Factor (dB).
 3. The other emission levels were very low against the limit.
 4. Margin value = Emission level – Limit value.
 5. “ * “: Fundamental frequency.
 6. “ # “: The radiated frequency falling in the restricted band.

EUT TEST CONDITION		MEASUREMENT DETAIL	
CHANNEL	Channel 1	FREQUENCY RANGE	1 ~ 40GHz
MODULATION TYPE	BPSK	DETECTOR FUNCTION	Peak (PK) Average (AV)
INPUT POWER (SYSTEM)	120Vac, 60Hz	ENVIRONMENTAL CONDITIONS	25deg. C, 65%RH, 991hPa
TEST MODE	E	TESTED BY	Long Chen

ANTENNA POLARITY & TEST DISTANCE: HORIZONTAL AT 3 M								
No.	Freq. (MHz)	Emission Level (dBuV/m)	Limit (dBuV/m)	Margin (dB)	Antenna Height (m)	Table Angle (Degree)	Raw Value (dBuV)	Correction Factor (dB/m)
1	#5150.00	72.89 PK	74.00	-1.11	1.00 H	142	34.52	38.37
2	#5150.00	52.85 AV	54.00	-1.15	1.00 H	142	14.48	38.37
3	*5180.00	114.19 PK			1.00 H	143	75.78	38.42
4	*5180.00	103.20 AV			1.00 H	143	64.79	38.42
5	6906.00	52.63 PK	88.30	-35.67	1.00 H	49	9.28	43.36
6	6906.00	41.55 AV	68.30	-26.75	1.00 H	49	-1.80	43.36
7	10360.00	63.87 PK	88.30	-24.43	1.24 H	340	15.12	48.75
8	10360.00	51.13 AV	68.30	-17.17	1.24 H	340	2.38	48.75

ANTENNA POLARITY & TEST DISTANCE: VERTICAL AT 3 M								
No.	Freq. (MHz)	Emission Level (dBuV/m)	Limit (dBuV/m)	Margin (dB)	Antenna Height (m)	Table Angle (Degree)	Raw Value (dBuV)	Correction Factor (dB/m)
1	#5150.00	70.26 PK	74.00	-3.74	1.02 V	211	31.90	38.37
2	#5150.00	50.35 AV	54.00	-3.65	1.02 V	211	11.98	38.37
3	*5180.00	98.02 PK			1.21 V	207	59.60	38.42
4	*5180.00	87.61 AV			1.21 V	207	49.19	38.42
5	6906.00	50.51 PK	88.30	-37.79	1.00 V	17	7.16	43.36
6	6906.00	38.33 AV	68.30	-29.97	1.00 V	17	-5.02	43.36
7	10360.00	60.47 PK	88.30	-27.83	1.43 V	241	11.72	48.75
8	10360.00	47.93 AV	68.30	-20.37	1.43 V	241	-0.82	48.75

- REMARKS:**
1. Emission level (dBuV/m) = Raw Value (dBuV) + Correction Factor (dB/m).
 2. Correction Factor (dB/m) = Antenna Factor (dB/m) + Cable Factor (dB).
 3. The other emission levels were very low against the limit.
 4. Margin value = Emission level – Limit value.
 5. “ * “: Fundamental frequency.
 6. “ # “: The radiated frequency falling in the restricted band.

EUT TEST CONDITION		MEASUREMENT DETAIL	
CHANNEL	Channel 2	FREQUENCY RANGE	1 ~ 40GHz
MODULATION TYPE	BPSK	DETECTOR FUNCTION	Peak (PK) Average (AV)
INPUT POWER (SYSTEM)	120Vac, 60Hz	ENVIRONMENTAL CONDITIONS	25deg. C, 65%RH, 991hPa
TEST MODE	E	TESTED BY	Long Chen

ANTENNA POLARITY & TEST DISTANCE: HORIZONTAL AT 3 M								
No.	Freq. (MHz)	Emission Level (dBuV/m)	Limit (dBuV/m)	Margin (dB)	Antenna Height (m)	Table Angle (Degree)	Raw Value (dBuV)	Correction Factor (dB/m)
1	*5200.00	116.51 PK			1.00 H	138	78.06	38.45
2	*5200.00	104.99 AV			1.00 H	138	66.54	38.45
3	6933.00	52.99 PK	88.30	-35.31	1.02 H	36	9.56	43.43
4	6933.00	43.14 AV	68.30	-25.16	1.02 H	36	-0.29	43.43
5	10400.00	64.78 PK	88.30	-23.52	1.11 H	346	15.95	48.83
6	10400.00	50.95 AV	68.30	-17.35	1.11 H	346	2.12	48.83

ANTENNA POLARITY & TEST DISTANCE: VERTICAL AT 3 M								
No.	Freq. (MHz)	Emission Level (dBuV/m)	Limit (dBuV/m)	Margin (dB)	Antenna Height (m)	Table Angle (Degree)	Raw Value (dBuV)	Correction Factor (dB/m)
1	*5200.00	98.65 PK			1.26 V	235	60.20	38.45
2	*5200.00	87.31 AV			1.26 V	235	48.86	38.45
3	6933.00	48.99 PK	88.30	-39.31	1.23 V	253	5.56	43.43
4	6933.00	40.02 AV	68.30	-28.28	1.23 V	253	-3.41	43.43
5	10400.00	60.21 PK	88.30	-28.09	1.65 V	8	11.38	48.83
6	10400.00	45.79 AV	68.30	-22.51	1.65 V	8	-3.04	48.83

- REMARKS:**
1. Emission level (dBuV/m) = Raw Value (dBuV) + Correction Factor (dB/m).
 2. Correction Factor (dB/m) = Antenna Factor (dB/m) + Cable Factor (dB).
 3. The other emission levels were very low against the limit.
 4. Margin value = Emission level – Limit value.
 5. “ * “: Fundamental frequency.
 6. “ # “: The radiated frequency falling in the restricted band.

EUT TEST CONDITION		MEASUREMENT DETAIL	
CHANNEL	Channel 4	FREQUENCY RANGE	1 ~ 40GHz
MODULATION TYPE	BPSK	DETECTOR FUNCTION	Peak (PK) Average (AV)
INPUT POWER (SYSTEM)	120Vac, 60Hz	ENVIRONMENTAL CONDITIONS	25deg. C, 65%RH, 991hPa
TEST MODE	E	TESTED BY	Long Chen

ANTENNA POLARITY & TEST DISTANCE: HORIZONTAL AT 3 M								
No.	Freq. (MHz)	Emission Level (dBuV/m)	Limit (dBuV/m)	Margin (dB)	Antenna Height (m)	Table Angle (Degree)	Raw Value (dBuV)	Correction Factor (dB/m)
1	*5240.00	116.66 PK			1.00 H	140	78.15	38.51
2	*5240.00	105.30 AV			1.00 H	140	66.79	38.51
3	#5350.00	57.62 PK	74.00	-16.38	1.00 H	140	18.95	38.66
4	#5350.00	46.70 AV	54.00	-7.30	1.00 H	140	8.04	38.66
5	6987.00	53.08 PK	88.30	-35.22	1.16 H	63	9.51	43.57
6	6987.00	43.75 AV	68.30	-24.55	1.16 H	63	0.18	43.57
7	10480.00	62.52 PK	88.30	-25.78	1.25 H	326	13.41	49.11
8	10480.00	50.31 AV	68.30	-17.99	1.25 H	326	1.20	49.11

ANTENNA POLARITY & TEST DISTANCE: VERTICAL AT 3 M								
No.	Freq. (MHz)	Emission Level (dBuV/m)	Limit (dBuV/m)	Margin (dB)	Antenna Height (m)	Table Angle (Degree)	Raw Value (dBuV)	Correction Factor (dB/m)
1	*5240.00	99.56 PK			1.25 V	213	61.05	38.51
2	*5240.00	88.69 AV			1.25 V	213	50.18	38.51
3	#5350.00	49.13 PK	74.00	-24.87	1.26 V	224	10.47	38.66
4	#5350.00	36.52 AV	54.00	-17.48	1.26 V	224	-2.14	38.66
5	6987.00	50.30 PK	88.30	-38.00	1.02 V	66	6.73	43.57
6	6987.00	40.20 AV	68.30	-28.10	1.02 V	66	-3.37	43.57
7	10480.00	58.79 PK	88.30	-29.51	1.02 V	3	9.68	49.11
8	10480.00	47.00 AV	68.30	-21.30	1.02 V	3	-2.11	49.11

- REMARKS:**
1. Emission level (dBuV/m) = Raw Value (dBuV) + Correction Factor (dB/m).
 2. Correction Factor (dB/m) = Antenna Factor (dB/m) + Cable Factor (dB).
 3. The other emission levels were very low against the limit.
 4. Margin value = Emission level – Limit value.
 5. “ * “: Fundamental frequency.
 6. “ # “: The radiated frequency falling in the restricted band.

802.11a OFDM MODULATION_TURBO MODE:

EUT TEST CONDITION		MEASUREMENT DETAIL	
CHANNEL	Channel 1	FREQUENCY RANGE	1 ~ 40GHz
MODULATION TYPE	QPSK	DETECTOR FUNCTION	Peak (PK) Average (AV)
INPUT POWER (SYSTEM)	120Vac, 60Hz	ENVIRONMENTAL CONDITIONS	25deg. C, 65%RH, 991hPa
TEST MODE	B	TESTED BY	Long Chen

ANTENNA POLARITY & TEST DISTANCE: HORIZONTAL AT 3 M								
No.	Freq. (MHz)	Emission Level (dBuV/m)	Limit (dBuV/m)	Margin (dB)	Antenna Height (m)	Table Angle (Degree)	Raw Value (dBuV)	Correction Factor (dB/m)
1	#5150.00	55.34 PK	74.00	-18.66	1.00 H	122	16.98	38.37
2	#5150.00	40.20 AV	54.00	-13.80	1.00 H	122	1.84	38.37
3	*5210.00	97.56 PK			1.00 H	122	59.10	38.46
4	*5210.00	86.50 AV			1.00 H	122	48.04	38.46
5	6947.00	52.89 PK	88.30	-35.41	1.06 H	22	9.43	43.46
6	6947.00	41.05 AV	68.30	-27.25	1.06 H	22	-2.41	43.46
7	10420.00	64.49 PK	88.30	-23.81	1.06 H	286	15.59	48.90
8	10420.00	50.00 AV	68.30	-18.30	1.06 H	286	1.10	48.90

ANTENNA POLARITY & TEST DISTANCE: VERTICAL AT 3 M								
No.	Freq. (MHz)	Emission Level (dBuV/m)	Limit (dBuV/m)	Margin (dB)	Antenna Height (m)	Table Angle (Degree)	Raw Value (dBuV)	Correction Factor (dB/m)
1	#5150.00	66.09 PK	74.00	-7.91	1.00 V	182	27.73	38.37
2	#5150.00	49.20 AV	54.00	-4.80	1.00 V	182	10.84	38.37
3	*5210.00	108.31 PK			1.00 V	182	69.85	38.46
4	*5210.00	97.11 AV			1.00 V	182	58.65	38.46
5	6947.00	53.85 PK	88.30	-34.45	1.02 V	68	10.39	43.46
6	6947.00	42.89 AV	68.30	-25.41	1.02 V	68	-0.57	43.46
7	10420.00	62.59 PK	88.30	-25.71	1.24 V	277	13.69	48.90
8	10420.00	48.00 AV	68.30	-20.30	1.24 V	277	-0.90	48.90

- REMARKS:**
1. Emission level (dBuV/m) = Raw Value (dBuV) + Correction Factor (dB/m).
 2. Correction Factor (dB/m) = Antenna Factor (dB/m) + Cable Factor (dB).
 3. The other emission levels were very low against the limit.
 4. Margin value = Emission level – Limit value.
 5. “ * “: Fundamental frequency.
 6. “ # “: The radiated frequency falling in the restricted band.

EUT TEST CONDITION		MEASUREMENT DETAIL	
CHANNEL	Channel 1	FREQUENCY RANGE	1 ~ 40GHz
MODULATION TYPE	QPSK	DETECTOR FUNCTION	Peak (PK) Average (AV)
INPUT POWER (SYSTEM)	120Vac, 60Hz	ENVIRONMENTAL CONDITIONS	25deg. C, 65%RH, 991hPa
TEST MODE	E	TESTED BY	Long Chen

ANTENNA POLARITY & TEST DISTANCE: HORIZONTAL AT 3 M								
No.	Freq. (MHz)	Emission Level (dBuV/m)	Limit (dBuV/m)	Margin (dB)	Antenna Height (m)	Table Angle (Degree)	Raw Value (dBuV)	Correction Factor (dB/m)
1	#5150.00	69.56 PK	74.00	-4.44	1.00 H	141	31.19	38.37
2	#5150.00	52.84 AV	54.00	-1.16	1.00 H	141	14.48	38.37
3	*5210.00	113.34 PK			1.00 H	141	74.88	38.46
4	*5210.00	102.21 AV			1.00 H	141	63.75	38.46
5	6947.00	54.31 PK	88.30	-33.99	1.12 H	53	10.85	43.46
6	6947.00	41.74 AV	68.30	-26.56	1.12 H	53	-1.72	43.46
7	10420.00	64.28 PK	88.30	-24.02	1.24 H	341	15.38	48.90
8	10420.00	51.25 AV	68.30	-17.05	1.24 H	341	2.35	48.90

ANTENNA POLARITY & TEST DISTANCE: VERTICAL AT 3 M								
No.	Freq. (MHz)	Emission Level (dBuV/m)	Limit (dBuV/m)	Margin (dB)	Antenna Height (m)	Table Angle (Degree)	Raw Value (dBuV)	Correction Factor (dB/m)
1	#5150.00	52.35 PK	74.00	-21.65	1.00 V	226	13.98	38.37
2	#5150.00	35.65 AV	54.00	-18.35	1.00 V	226	-2.72	38.37
3	*5210.00	96.13 PK			1.00 V	226	57.67	38.46
4	*5210.00	85.02 AV			1.00 V	226	46.56	38.46
5	6947.00	52.23 PK	88.30	-36.07	1.47 V	175	8.77	43.46
6	6947.00	39.91 AV	68.30	-28.39	1.47 V	175	-3.55	43.46
7	10420.00	62.11 PK	88.30	-26.19	1.45 V	255	13.21	48.90
8	10420.00	49.55 AV	68.30	-18.75	1.45 V	255	0.65	48.90

- REMARKS:**
1. Emission level (dBuV/m) = Raw Value (dBuV) + Correction Factor (dB/m).
 2. Correction Factor (dB/m) = Antenna Factor (dB/m) + Cable Factor (dB).
 3. The other emission levels were very low against the limit.
 4. Margin value = Emission level – Limit value.
 5. “ * “: Fundamental frequency.
 6. “ # ”: The radiated frequency falling in the restricted band.



BELOW 1GHz WORST-CASE DATA: 802.11a OFDM MODULATION_NORMAL MODE:

EUT TEST CONDITION		MEASUREMENT DETAIL	
CHANNEL	Channel 2	FREQUENCY RANGE	Below 1000MHz
MODULATION TYPE	BPSK	DETECTOR FUNCTION	Quasi-Peak
ENVIRONMENTAL CONDITIONS	24deg. C, 67%RH, 991hPa	INPUT POWER (SYSTEM)	120Vac, 60Hz
TEST MODE	B	TESTED BY	Long Chen

ANTENNA POLARITY & TEST DISTANCE: HORIZONTAL AT 3 M								
No.	Freq. (MHz)	Emission Level (dBuV/m)	Limit (dBuV/m)	Margin (dB)	Antenna Height (m)	Table Angle (Degree)	Raw Value (dBuV)	Correction Factor (dB/m)
1	131.00	39.46 QP	43.50	-4.04	1.50 H	61	26.21	13.25
2	166.00	38.80 QP	43.50	-4.70	1.50 H	349	24.74	14.06
3	199.05	39.64 QP	43.50	-3.86	1.00 H	199	28.30	11.34
4	267.10	39.73 QP	46.00	-6.27	1.00 H	139	25.55	14.19
5	331.26	44.81 QP	46.00	-1.19	1.00 H	340	28.84	15.97
6	531.53	36.37 QP	46.00	-9.63	1.50 H	205	15.48	20.90
7	928.16	38.83 QP	46.00	-7.17	1.00 H	244	10.82	28.00

ANTENNA POLARITY & TEST DISTANCE: VERTICAL AT 3 M								
No.	Freq. (MHz)	Emission Level (dBuV/m)	Limit (dBuV/m)	Margin (dB)	Antenna Height (m)	Table Angle (Degree)	Raw Value (dBuV)	Correction Factor (dB/m)
1	59.06	38.82 QP	40.00	-1.18	1.00 V	70	24.76	14.06
2	111.56	36.60 QP	43.50	-6.90	1.00 V	76	25.00	11.61
3	169.89	34.31 QP	43.50	-9.19	1.00 V	76	20.55	13.76
4	333.21	41.80 QP	46.00	-4.20	1.50 V	181	25.78	16.02
5	665.68	34.92 QP	46.00	-11.08	1.00 V	334	11.14	23.78
6	933.99	39.98 QP	46.00	-6.02	1.50 V	196	11.89	28.09

- REMARKS:**
1. Emission level (dBuV/m) = Raw Value (dBuV) + Correction Factor (dB/m).
 2. Correction Factor (dB/m) = Antenna Factor (dB/m) + Cable Factor (dB).
 3. The other emission levels were very low against the limit.
 4. Margin value = Emission level – Limit value.

EUT TEST CONDITION		MEASUREMENT DETAIL	
CHANNEL	Channel 2	FREQUENCY RANGE	Below 1000MHz
MODULATION TYPE	BPSK	DETECTOR FUNCTION	Quasi-Peak
ENVIRONMENTAL CONDITIONS	24deg. C, 67%RH, 991hPa	INPUT POWER (SYSTEM)	120Vac, 60Hz
TEST MODE	E	TESTED BY	Long Chen

ANTENNA POLARITY & TEST DISTANCE: HORIZONTAL AT 3 M								
No.	Freq. (MHz)	Emission Level (dBuV/m)	Limit (dBuV/m)	Margin (dB)	Antenna Height (m)	Table Angle (Degree)	Raw Value (dBuV)	Correction Factor (dB/m)
1	99.89	40.53 QP	43.50	-2.97	1.50 H	187	30.35	10.18
2	132.95	42.20 QP	43.50	-1.30	1.50 H	169	28.84	13.36
3	166.00	42.04 QP	43.50	-1.46	1.50 H	328	27.98	14.06
4	199.05	42.24 QP	43.50	-1.26	1.50 H	187	30.90	11.34
5	333.21	43.09 QP	46.00	-2.91	1.50 H	340	27.06	16.02
6	531.53	37.19 QP	46.00	-8.81	1.50 H	70	16.30	20.90
7	862.06	37.79 QP	46.00	-8.21	1.50 H	265	10.67	27.11

ANTENNA POLARITY & TEST DISTANCE: VERTICAL AT 3 M								
No.	Freq. (MHz)	Emission Level (dBuV/m)	Limit (dBuV/m)	Margin (dB)	Antenna Height (m)	Table Angle (Degree)	Raw Value (dBuV)	Correction Factor (dB/m)
1	53.23	36.40 QP	40.00	-3.60	1.00 V	340	21.79	14.61
2	64.90	37.67 QP	40.00	-2.33	1.50 V	124	24.32	13.35
3	99.89	42.04 QP	43.50	-1.46	1.00 V	79	31.86	10.18
4	166.00	34.71 QP	43.50	-8.79	1.50 V	118	20.66	14.06
5	333.21	38.02 QP	46.00	-7.98	1.50 V	154	22.00	16.02
6	533.47	34.53 QP	46.00	-11.47	1.50 V	340	13.59	20.93
7	928.16	39.55 QP	46.00	-6.45	1.50 V	301	11.54	28.00

- REMARKS:**
1. Emission level(dBuV/m)=Raw Value(dBuV) + Correction Factor(dB/m)
 2. Correction Factor(dB/m) = Antenna Factor (dB/m) + Cable Factor (dB)
 3. The other emission levels were very low against the limit.
 4. Margin value = Emission level – Limit value.

4.2 CONDUCTED EMISSION MEASUREMENT

4.2.1 LIMITS OF CONDUCTED EMISSION MEASUREMENT

FREQUENCY OF EMISSION (MHz)	CONDUCTED LIMIT (dB μ V)	
	Quasi-peak	Average
0.15 ~ 0.5	66 to 56	56 to 46
0.5 ~ 5	56	46
5 ~ 30	60	50

- NOTE:**
1. The lower limit shall apply at the transition frequencies.
 2. The limit decreases in line with the logarithm of the frequency in the range of 0.15 to 0.50MHz.
 3. All emanations from a class A/B digital device or system, including any network of conductors and apparatus connected thereto, shall not exceed the level of field strengths specified above.

4.2.2 TEST INSTRUMENTS

DESCRIPTION & MANUFACTURER	MODEL NO.	SERIAL NO.	CALIBRATED UNTIL
Test Receiver ROHDE & SCHWARZ	ESCS30	100289	Dec. 08, 2007
RF signal cable Woken	5D-FB	Cable-HYCO3-01	Jan. 06, 2008
LISN ROHDE & SCHWARZ	ESH2-Z5	100100	Jan. 08, 2008
LISN ROHDE & SCHWARZ	ESH3-Z5	100311	Jan. 16, 2008
Software ADT	ADT_Cond_V3	NA	NA

- NOTE:**
1. The calibration interval of the above test instruments is 12 months and the calibrations are traceable to NML/ROC and NIST/USA.
 2. The test was performed in HwaYa Shielded Room 2.
 3. The VCCI Site Registration No. is C-2047.

4.2.3 TEST PROCEDURES

- a. The EUT was placed 0.4 meters from the conducting wall of the shielded room with EUT being connected to the power mains through a line impedance stabilization network (LISN). Other support units were connected to the power mains through another LISN. The two LISNs provide 50 ohm/ 50uH of coupling impedance for the measuring instrument.
- b. Both lines of the power mains connected to the EUT were checked for maximum conducted interference.
- c. The frequency range from 150kHz to 30MHz was searched. Emission levels under (Limit - 20dB) was not recorded.

NOTE: All modes of operation were investigated and the worst-case emissions are reported.

4.2.4 DEVIATION FROM TEST STANDARD

No deviation

4.2.5 TEST SETUP

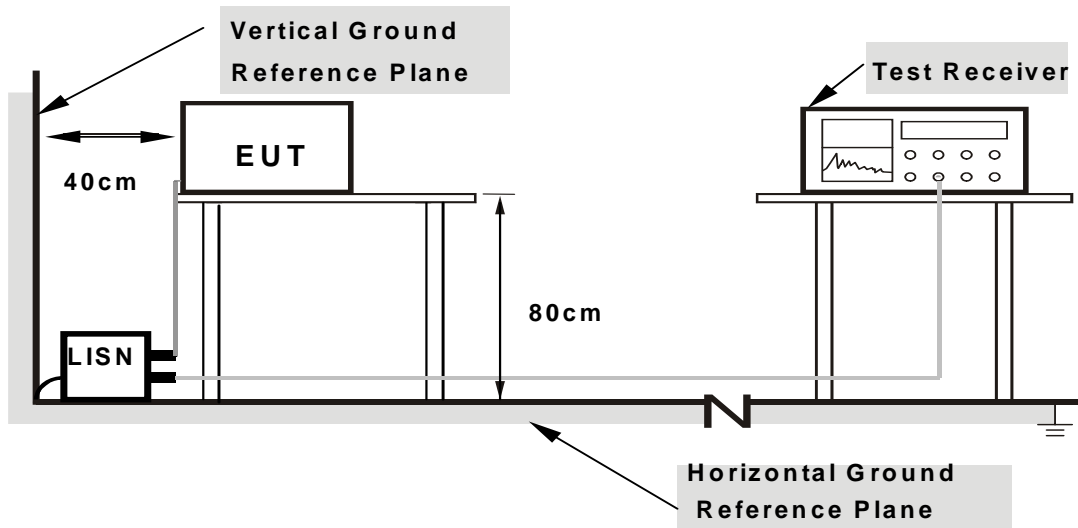

Note: 1. Support units were connected to second LISN.

2. Both of LISNs (AMN) are 80 cm from EUT and at least 80 cm from other units and other metal planes

For the actual test configuration, please refer to the related item – Photographs of the Test Configuration.

4.2.6 EUT OPERATING CONDITIONS

Same as 4.1.7

4.2.7 TEST RESULTS

CONDUCTED WORST-CASE DATA: 802.11a OFDM MODULATION NORMAL MODE:

EUT TEST CONDITION		MEASUREMENT DETAIL	
CHANNEL	Channel 2	PHASE	Line 1
MODULATION TYPE	BPSK	INPUT POWER (SYSTEM)	120Vac, 60Hz
ENVIRONMENTAL CONDITIONS	26deg. C, 68%RH, 991hPa	6dB BANDWIDTH	9kHz
TEST MODE	E	TESTED BY	Kevin Liang

No	Freq. [MHz]	Corr. Factor [dB]	Reading Value [dB (uV)]		Emission Level [dB (uV)]		Limit [dB (uV)]		Margin (dB)	
			Q.P.	AV.	Q.P.	AV.	Q.P.	AV.	Q.P.	AV.
1	0.209	0.10	45.32	-	45.42	-	63.26	53.26	-17.84	-
2	0.314	0.10	31.02	-	31.12	-	59.86	49.86	-28.74	-
3	0.505	0.10	22.22	-	22.32	-	56.00	46.00	-33.68	-
4	1.531	0.17	26.64	-	26.81	-	56.00	46.00	-29.19	-
5	3.941	0.28	21.86	-	22.14	-	56.00	46.00	-33.86	-
6	9.945	0.33	26.87	-	27.20	-	60.00	50.00	-32.80	-

- REMARKS:**
1. Q.P. and AV. are abbreviations of quasi-peak and average individually.
 2. "-": The Quasi-peak reading value also meets average limit and measurement with the average detector is unnecessary.
 3. The emission levels of other frequencies were very low against the limit.
 4. Margin value = Emission level - Limit value
 5. Correction factor = Insertion loss + Cable loss
 6. Emission Level = Correction Factor + Reading Value.

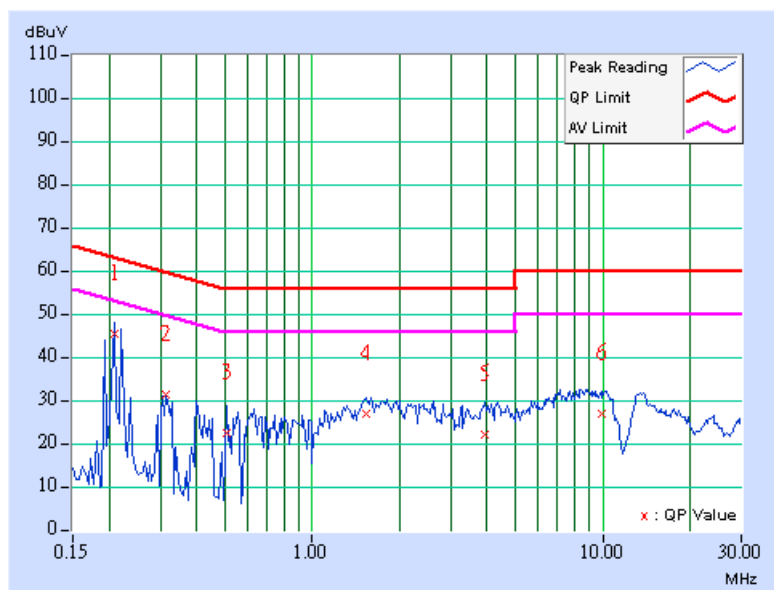

EUT TEST CONDITION		MEASUREMENT DETAIL	
CHANNEL	Channel 2	PHASE	Line 2
MODULATION TYPE	BPSK	INPUT POWER (SYSTEM)	120Vac, 60Hz
ENVIRONMENTAL CONDITIONS	26deg. C, 68%RH, 991hPa	6dB BANDWIDTH	9kHz
TEST MODE	E	TESTED BY	Kevin Liang

No	Freq. [MHz]	Corr. Factor [dB]	Reading Value [dB (uV)]		Emission Level [dB (uV)]		Limit [dB (uV)]		Margin (dB)	
			Q.P.	AV.	Q.P.	AV.	Q.P.	AV.	Q.P.	AV.
1	0.154	0.10	50.78	-	50.88	-	65.79	55.79	-14.91	-
2	0.197	0.10	41.65	-	41.75	-	63.74	53.74	-21.99	-
3	0.224	0.10	42.58	-	42.68	-	62.66	52.66	-19.98	-
4	1.500	0.22	27.71	-	27.93	-	56.00	46.00	-28.07	-
5	4.480	0.29	22.92	-	23.21	-	56.00	46.00	-32.79	-
6	9.090	0.41	27.05	-	27.46	-	60.00	50.00	-32.54	-

- REMARKS:**
1. Q.P. and AV. are abbreviations of quasi-peak and average individually.
 2. "-": The Quasi-peak reading value also meets average limit and measurement with the average detector is unnecessary.
 3. The emission levels of other frequencies were very low against the limit.
 4. Margin value = Emission level - Limit value
 5. Correction factor = Insertion loss + Cable loss
 6. Emission Level = Correction Factor + Reading Value.

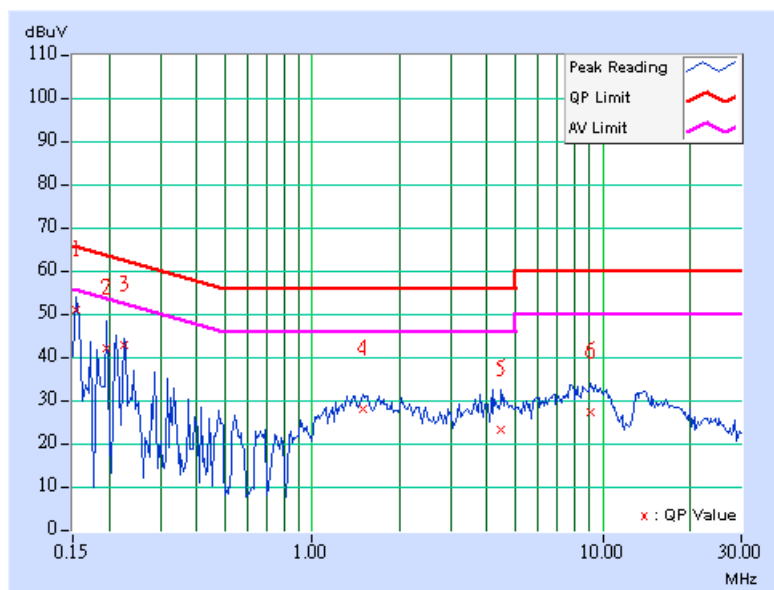

4.3 PEAK TRANSMIT POWER MEASUREMENT

4.3.1 LIMITS OF PEAK TRANSMIT POWER MEASUREMENT

FREQUENCY BAND	LIMIT
5.150 ~ 5.250GHz	The lesser of 50mW (17dBm) or 4dBm + 10logB
5.250 ~ 5.350GHz	The lesser of 250mW (24dBm) or 11dBm + 10logB
5.470 ~ 5.725GHz	The lesser of 250mW (24dBm) or 11dBm + 10logB

NOTE: Where B is the 26dB emission bandwidth in MHz.

4.3.2 TEST INSTRUMENTS

DESCRIPTION & MANUFACTURER	MODEL NO.	SERIAL NO.	CALIBRATED UNTIL
R&S SPECTRUM ANALYZER	FSP40	100040	Jun. 28, 2008

NOTE: The calibration interval of the above test instruments is 12 months and the calibrations are traceable to NML/ROC and NIST/USA.

4.3.3 TEST PROCEDURE

1. The transmitter output was connected to the spectrum analyzer.
2. Set span to encompass the entire emission bandwidth of the signal.
3. Set RBW to 1MHz, VBW to 3MHz.
4. Using the spectrum analyzer's channel power measurement function to measure the output power.

NOTE: The test is performed in accordance with FCC Public Notice: APPENDIX A Guidelines for Assessing Unlicensed National Information Infrastructure (U-NII) Devices – Part 15, Subpart E, August 2002.

The transmitter output operates continuously therefore Method # 3 is used.

4.3.4 DEVIATION FROM TEST STANDARD

No deviation

4.3.5 TEST SETUP

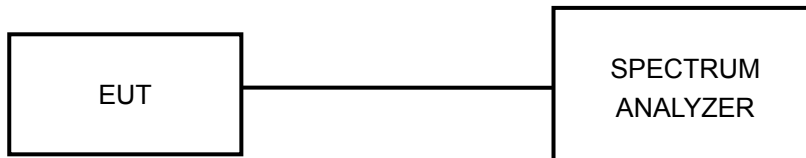

4.3.6 EUT OPERATING CONDITIONS

The software provided by client to enable the EUT under transmission condition continuously at specific channel frequencies individually.

4.3.7 TEST RESULTS

PEAK POWER OUTPUT: 802.11a OFDM MODULATION_NORMAL MODE:

MODULATION TYPE	BPSK	ENVIRONMENTAL CONDITIONS	23deg.C, 69%RH, 991hPa
INPUT POWER (SYSTEM)	120Vac, 60Hz	TESTED BY	Long Chen

CHANNEL	CHANNEL FREQUENCY (MHz)	PEAK POWER OUTPUT (mW)	PEAK POWER OUTPUT (dBm)	PEAK POWER LIMIT (dBm)	PASS / FAIL
1	5180	20.184	13.05	15.00	PASS
2	5200	28.907	14.61	15.00	PASS
4	5240	28.445	14.54	15.00	PASS

NOTE: According to 15.407(a)(1)(2), the maximum antenna gain 8dBi is higher than 6dBi, so the limit of peak power shall be reduced by 2dB.

CH 1

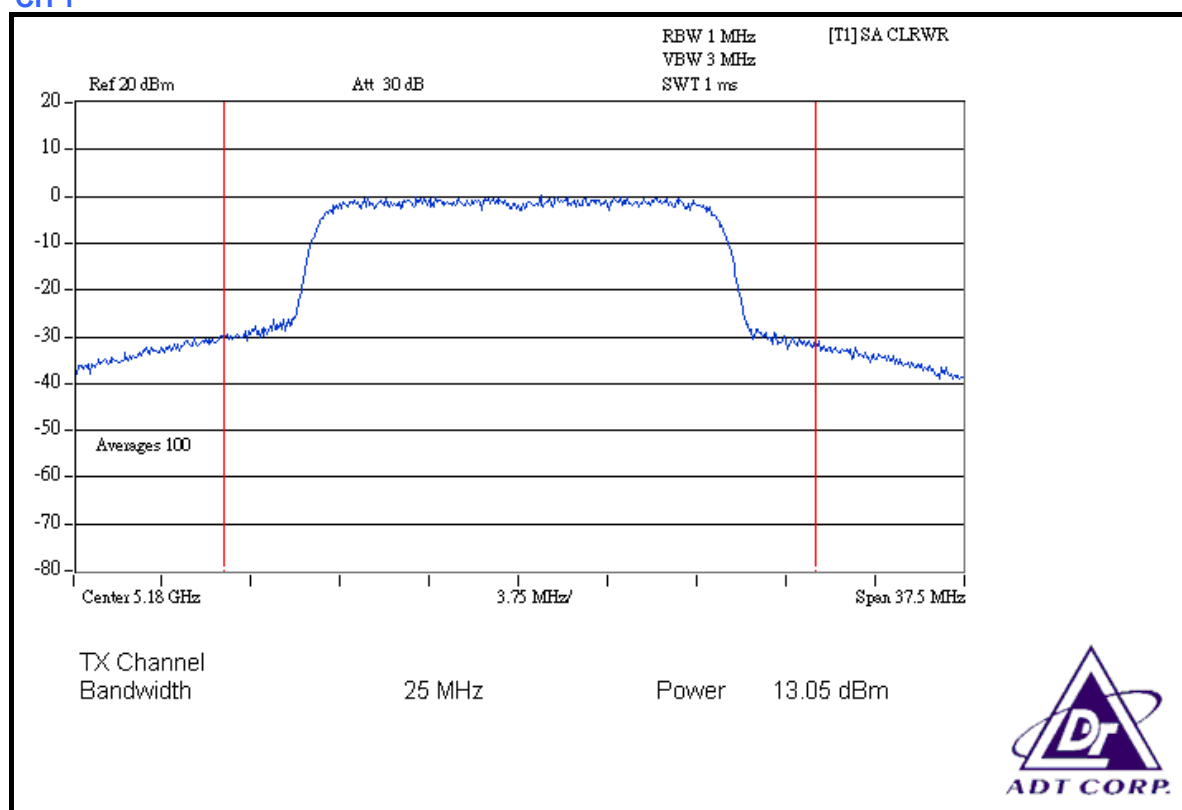

CH 2

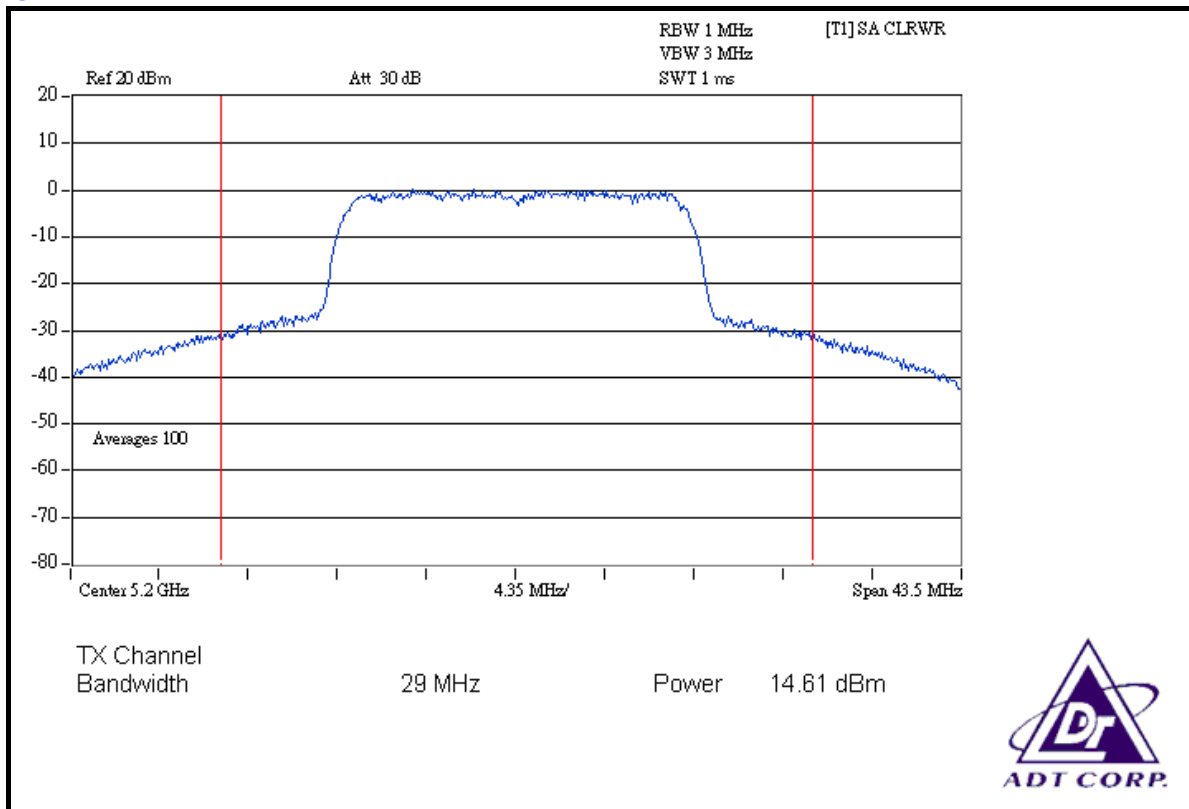

CH 4

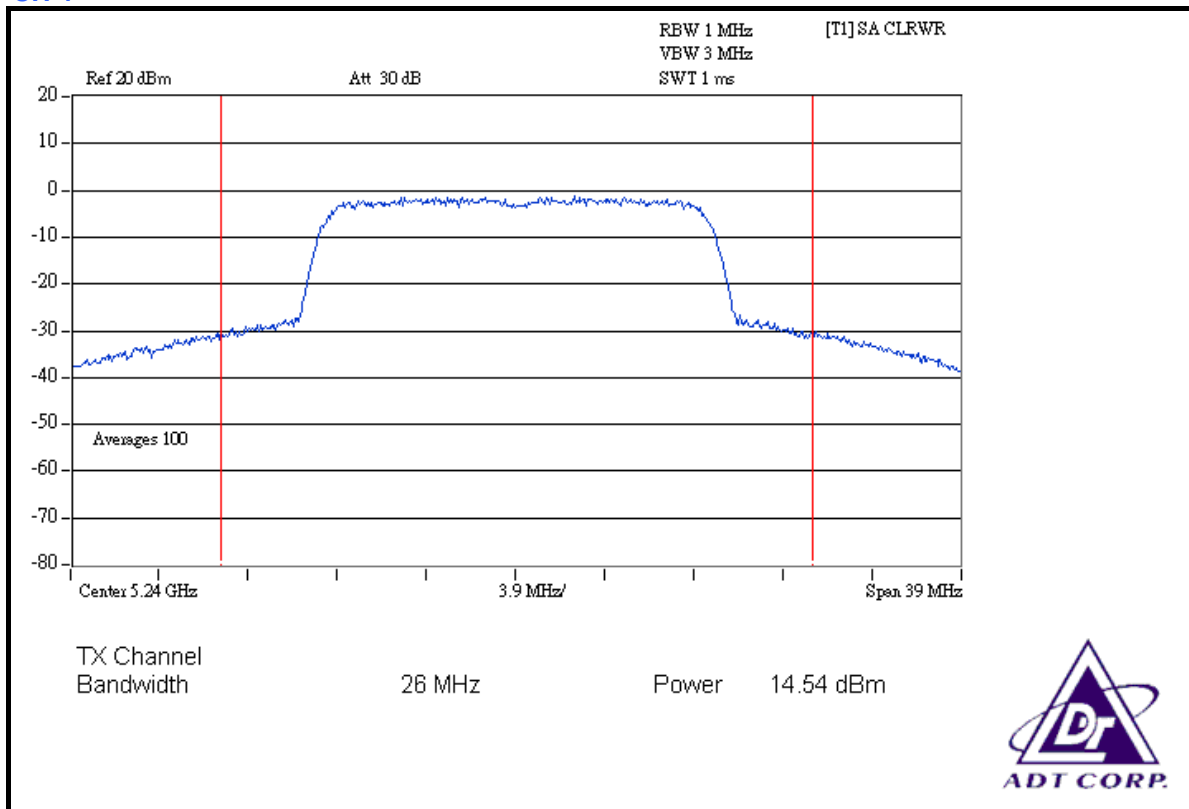



PEAK POWER OUTPUT: 802.11a OFDM MODULATION_TURBO MODE:

MODULATION TYPE	QPSK	ENVIRONMENTAL CONDITIONS	23deg.C, 69%RH, 991hPa
INPUT POWER (SYSTEM)	120Vac, 60Hz	TESTED BY	Long Chen

CHANNEL	CHANNEL FREQUENCY (MHz)	PEAK POWER OUTPUT (mW)	PEAK POWER OUTPUT (dBm)	PEAK POWER LIMIT (dBm)	PASS / FAIL
1	5210	28.642	14.57	15.00	PASS

NOTE: According to 15.407(a)(1)(2), the maximum antenna gain 8dBi is higher than 6dBi, so the limit of peak power shall be reduced by 2dB.

CH 1

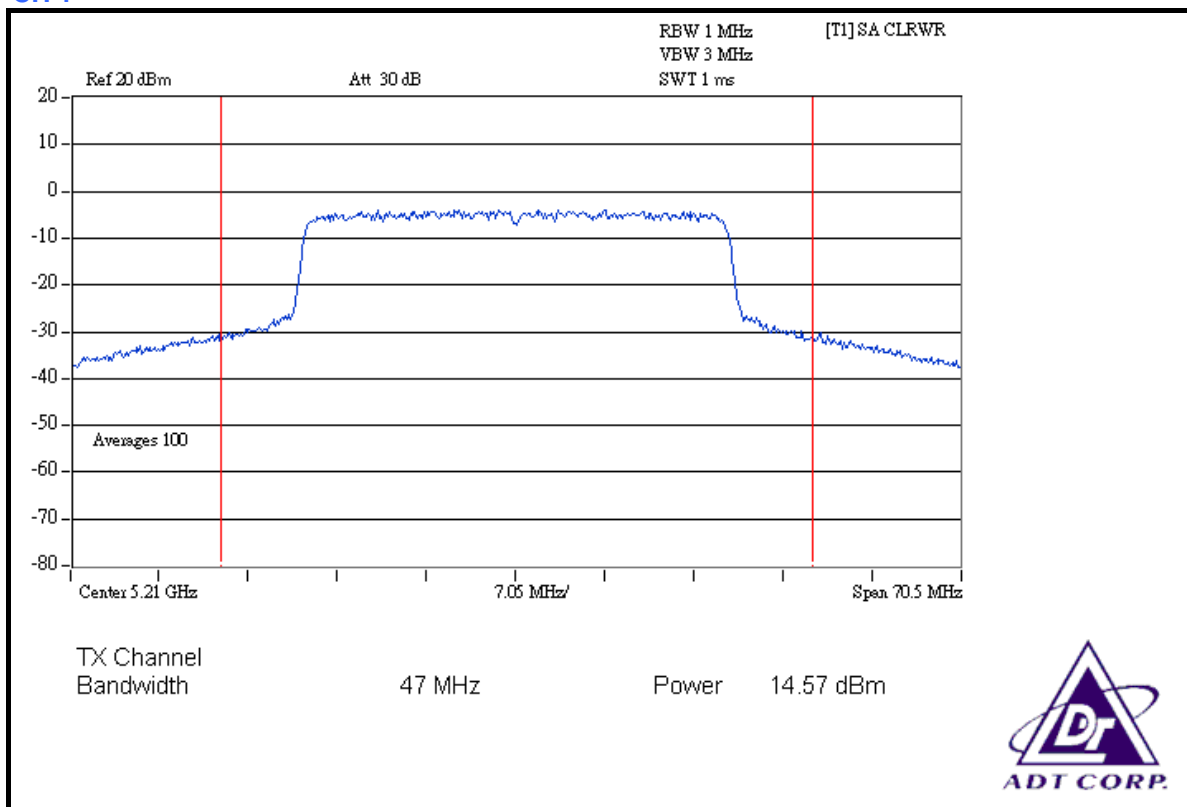



26dB OCCUPIED BANDWIDTH: 802.11a OFDM MODULATION_NORMAL MODE:

MODULATION TYPE	BPSK	ENVIRONMENTAL CONDITIONS	23deg.C, 69%RH, 991hPa
INPUT POWER (SYSTEM)	120Vac, 60Hz	TESTED BY	Long Chen

CHANNEL	CHANNEL FREQUENCY (MHz)	26dBc OCCUPIED BANDWIDTH (MHz)	PASS / FAIL
1	5180	24.33	PASS
2	5200	28.20	PASS
4	5240	25.33	PASS

CH 1

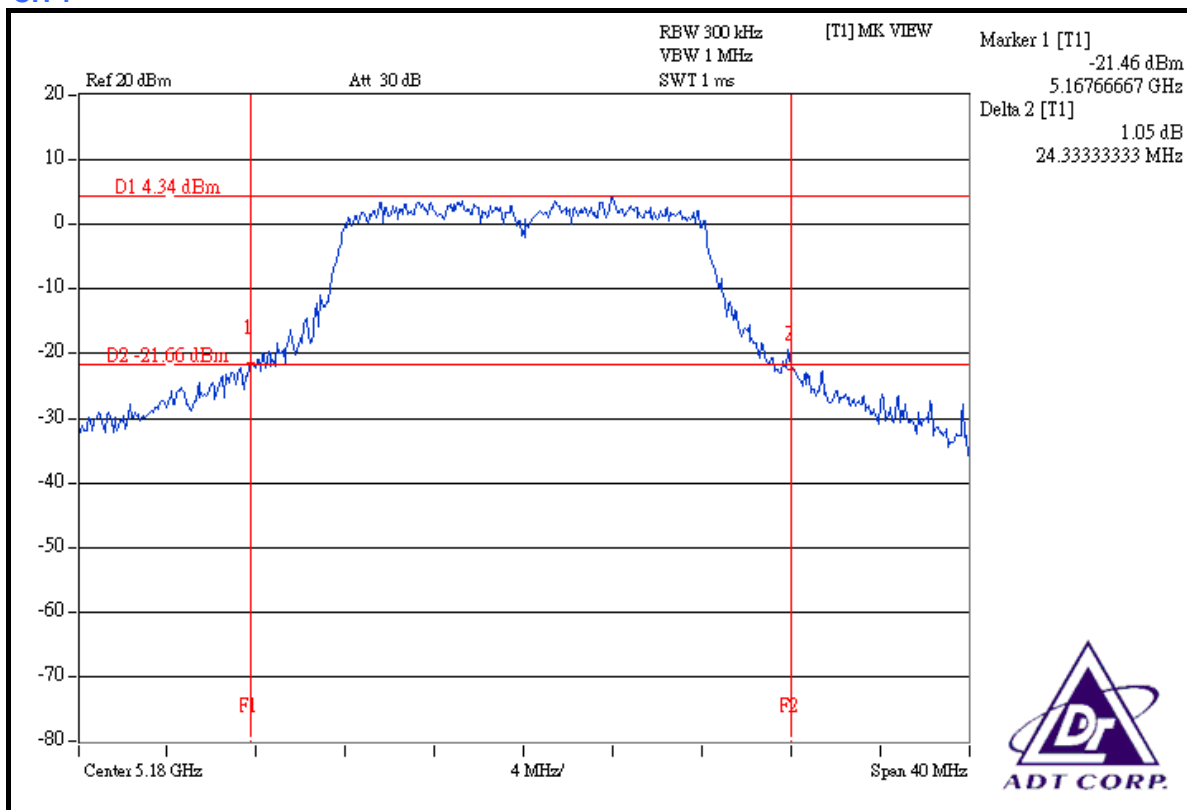

CH 2

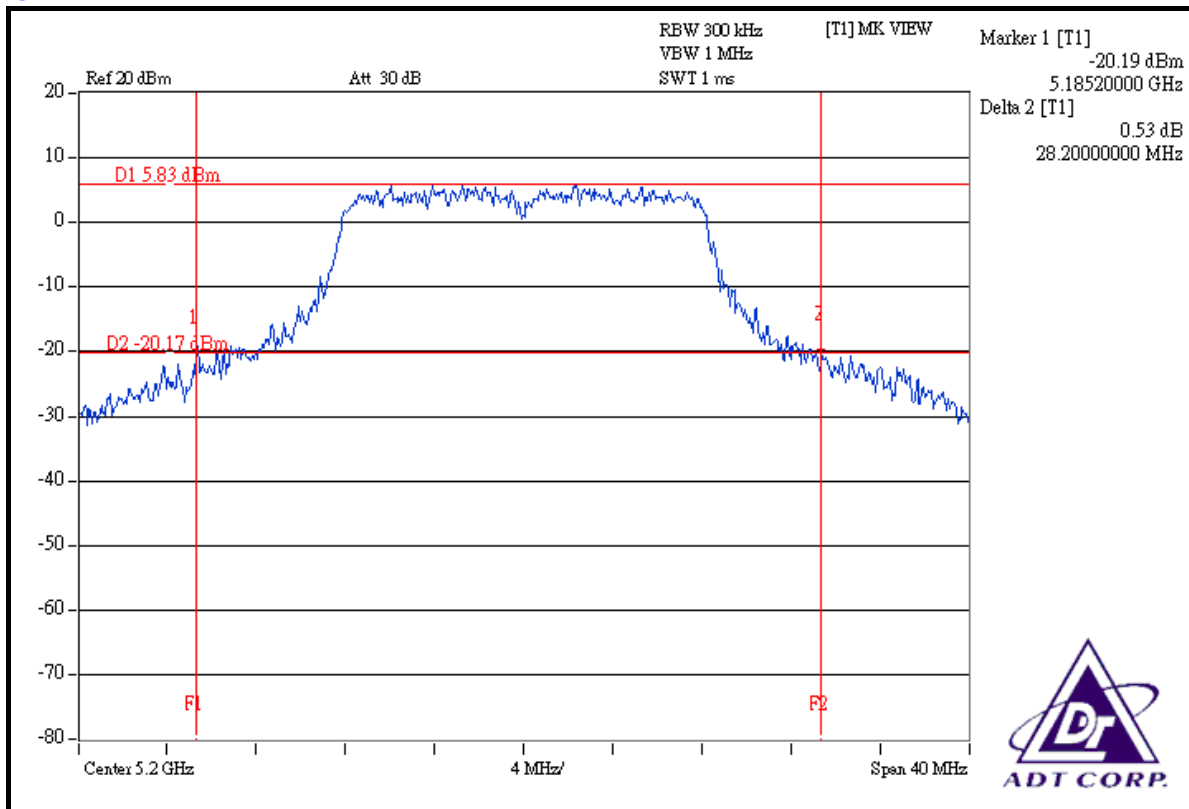

CH 4

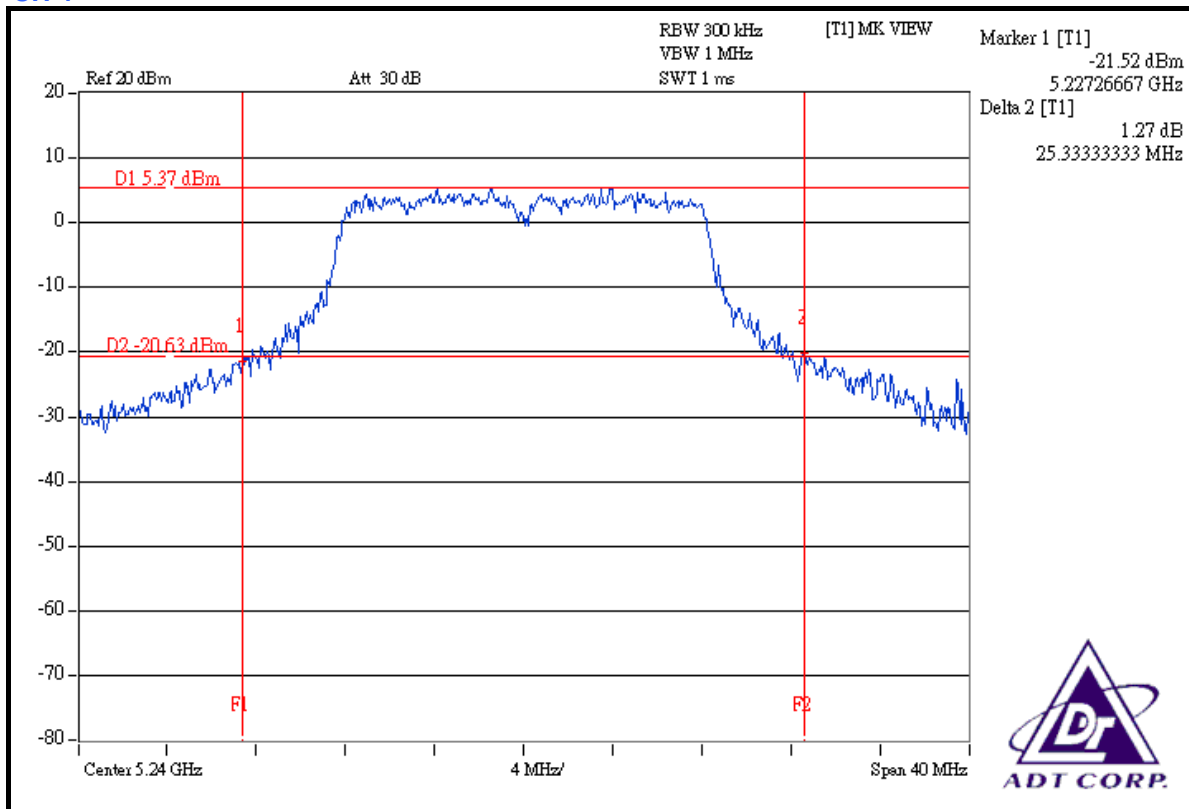



26dB OCCUPIED BANDWIDTH: 802.11a OFDM MODULATION_TURBO MODE:

MODULATION TYPE	QPSK	ENVIRONMENTAL CONDITIONS	23deg.C, 69%RH, 991hPa
INPUT POWER (SYSTEM)	120Vac, 60Hz	TESTED BY	Long Chen

CHANNEL	CHANNEL FREQUENCY (MHz)	26dBc OCCUPIED BANDWIDTH (MHz)	PASS / FAIL
1	5210	46.13	PASS

CH 1

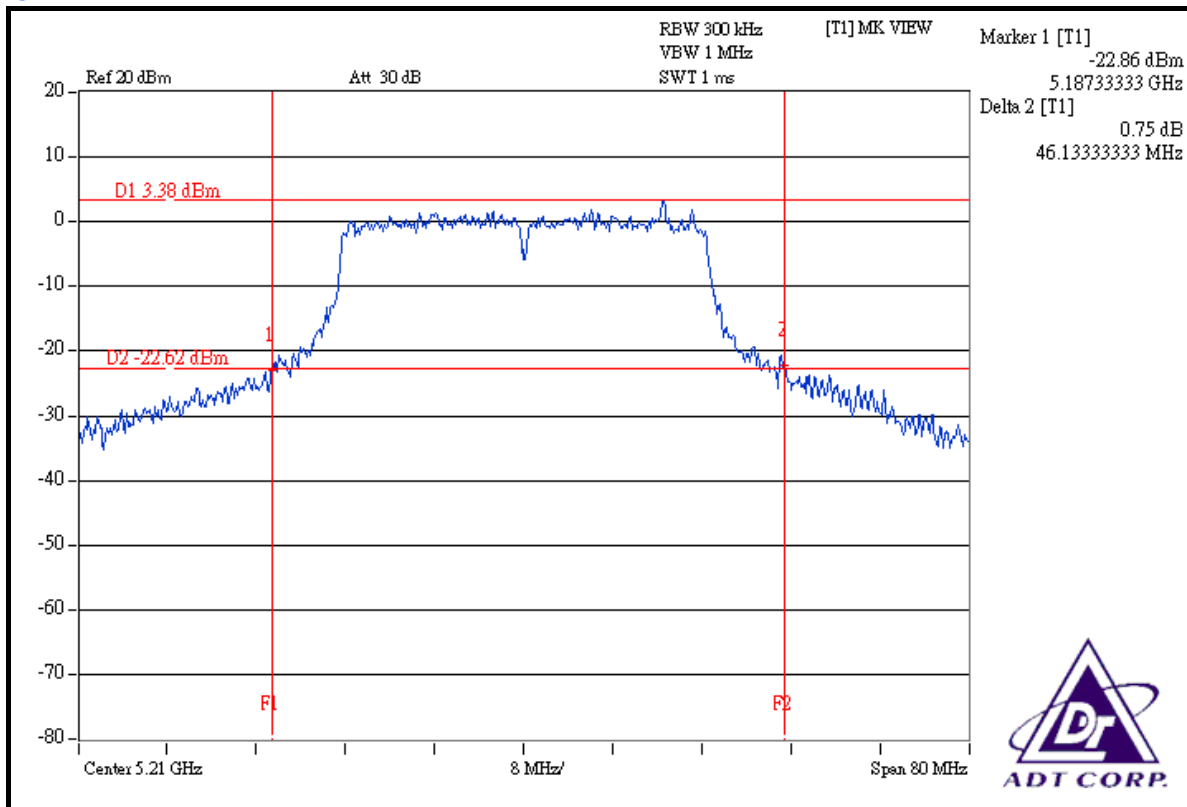

4.4 PEAK POWER EXCURSION MEASUREMENT

4.4.1 LIMITS OF PEAK POWER EXCURSION MEASUREMENT

FREQUENCY BAND	LIMIT
5.150 ~ 5.250GHz	13dB
5.250 ~ 5.350GHz	13dB
5.470 ~ 5.725GHz	13dB

4.4.2 TEST INSTRUMENTS

DESCRIPTION & MANUFACTURER	MODEL NO.	SERIAL NO.	CALIBRATED UNTIL
R&S SPECTRUM ANALYZER	FSP40	100040	Jun. 28, 2008

NOTE: The calibration interval of the above test instruments is 12 months and the calibrations are traceable to NML/ROC and NIST/USA.

4.4.3 TEST PROCEDURE

1. The transmitter output was connected to the spectrum analyzer.
2. Set the spectrum bandwidth span to view the entire spectrum.
3. Using peak detector and Max-hold function for Trace 1 (RB = 1MHz, VB = 3MHz) and 2 (RB = 1MHz, VB = 300kHz).
4. The largest difference between Trace 1 and Trace 2 in any 1MHz band on any frequency was recorded.

4.4.4 DEVIATION FROM TEST STANDARD

No deviation

4.4.5 TEST SETUP

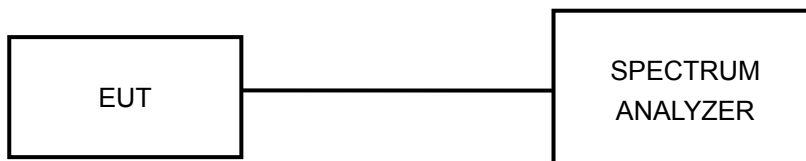

4.4.6 EUT OPERATING CONDITIONS

The software provided by client to enable the EUT under transmission condition continuously at specific channel frequencies individually.



4.4.7 TEST RESULTS

802.11a OFDM MODULATION_NORMAL MODE:

MODULATION TYPE	BPSK	ENVIRONMENTAL CONDITIONS	23deg.C, 69%RH, 991hPa
INPUT POWER (SYSTEM)	120Vac, 60Hz	TESTED BY	Long Chen

CHANNEL	CHANNEL FREQUENCY (MHz)	PEAK POWER EXCURSION (dB)	PEAK TO AVERAGE EXCURSION LIMIT (dB)	PASS / FAIL
1	5180	8.92	13	PASS
2	5200	8.52	13	PASS
4	5240	8.59	13	PASS

CH 1

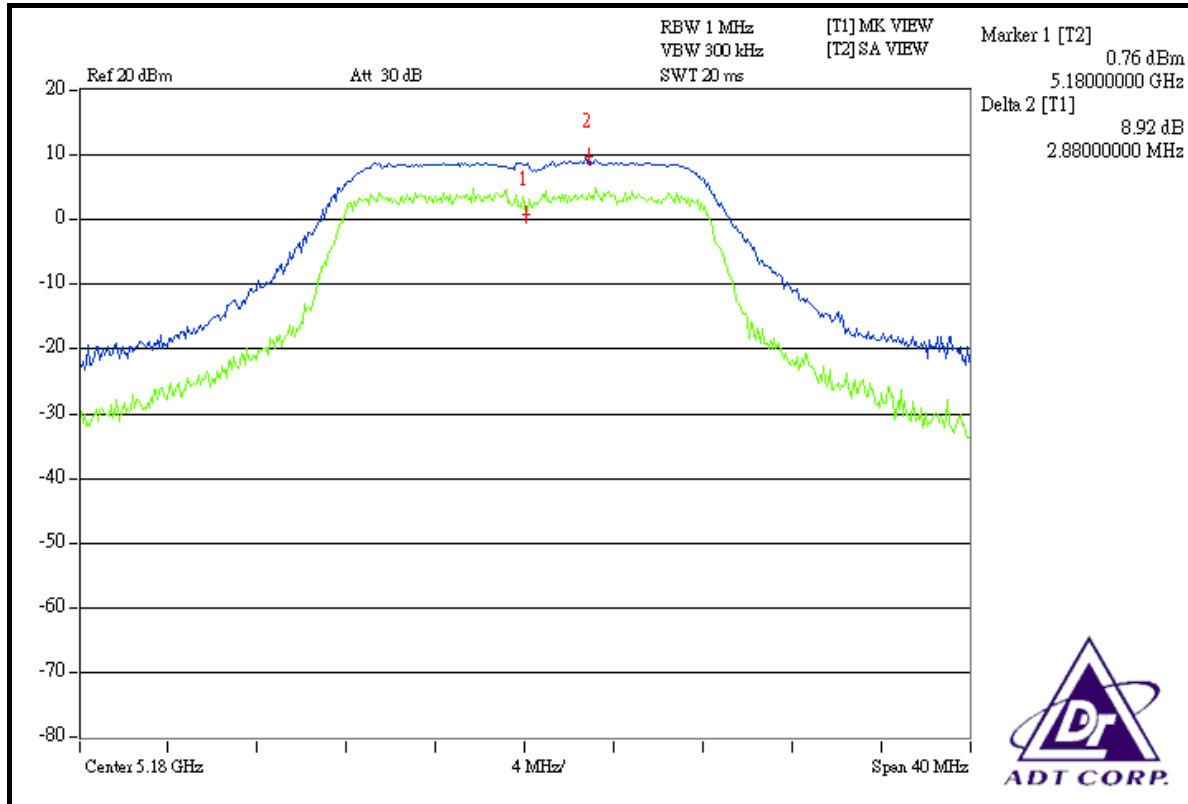



CH 2

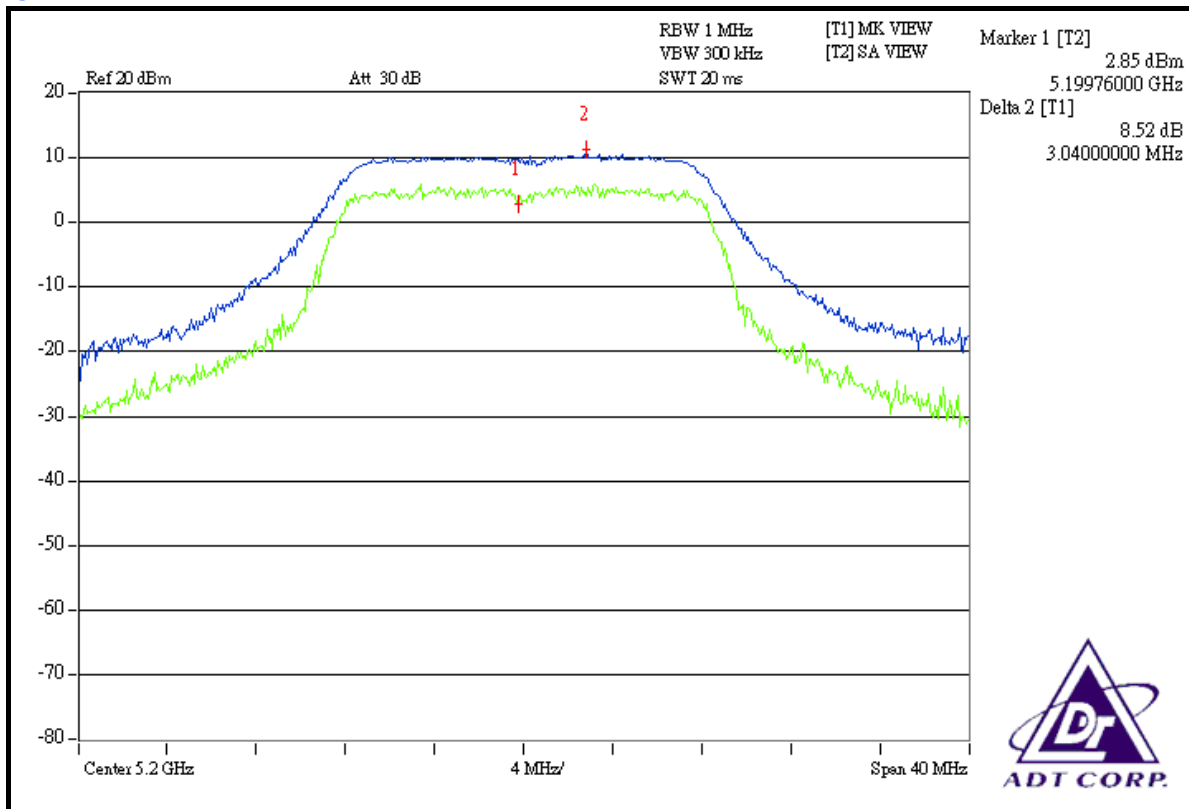

CH 4

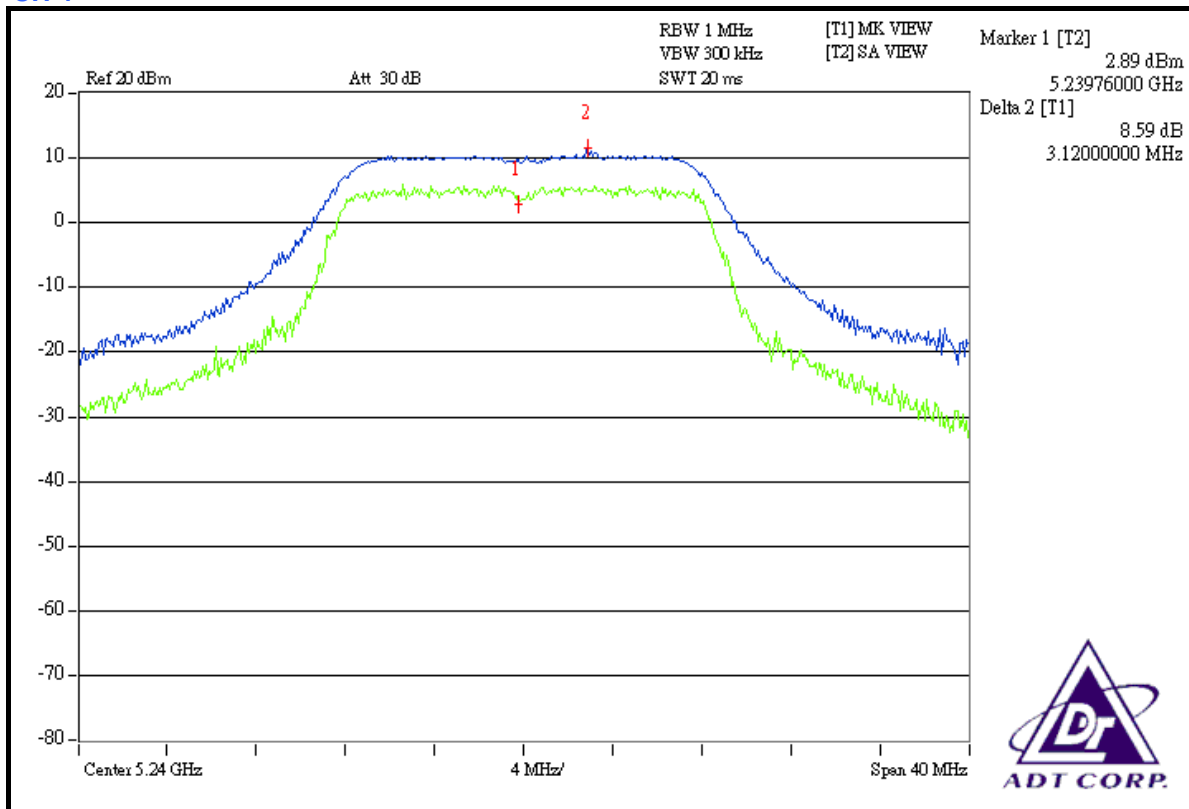



802.11a OFDM MODULATION_TURBO MODE:

MODULATION TYPE	QPSK	ENVIRONMENTAL CONDITIONS	23deg.C, 69%RH, 991hPa
INPUT POWER (SYSTEM)	120Vac, 60Hz	TESTED BY	Long Chen

CHANNEL	CHANNEL FREQUENCY (MHz)	PEAK POWER EXCURSION (dB)	PEAK TO AVERAGE EXCURSION LIMIT (dB)	PASS / FAIL
1	5210	8.94	13	PASS

CH 1

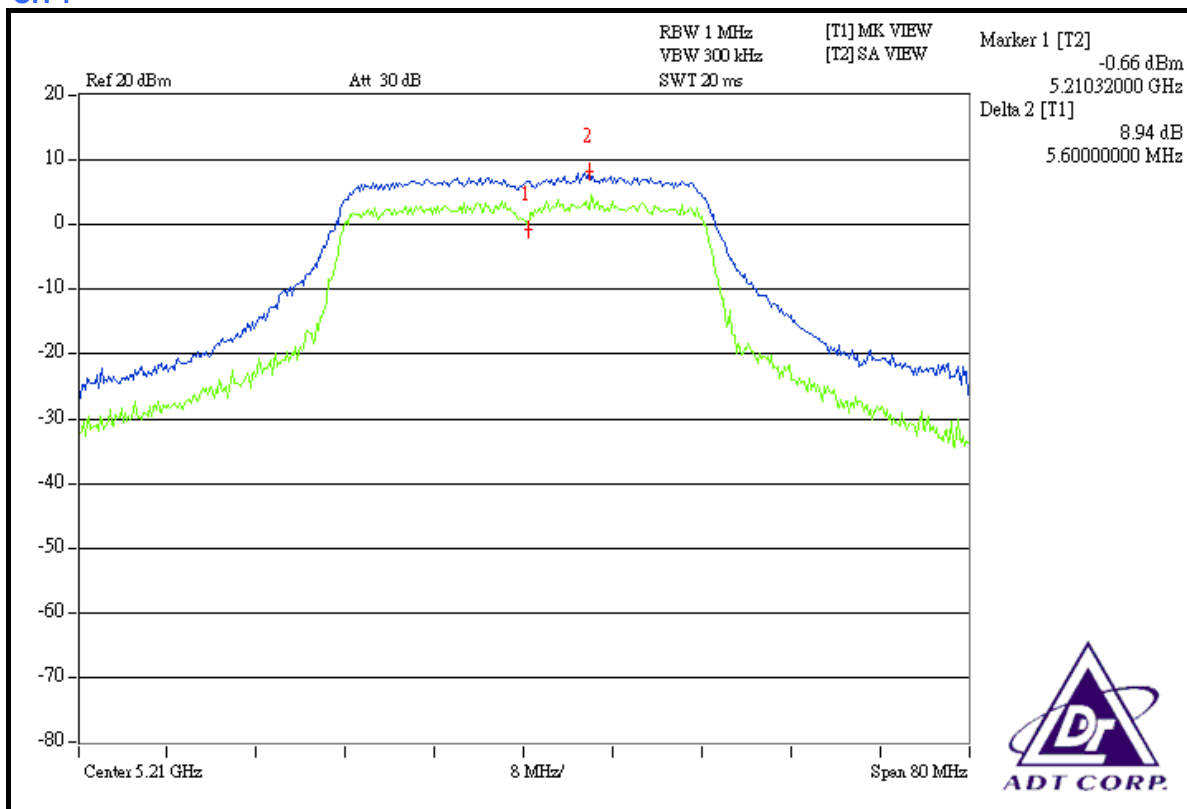

4.5 PEAK POWER SPECTRAL DENSITY MEASUREMENT

4.5.1 LIMITS OF PEAK POWER SPECTRAL DENSITY MEASUREMENT

FREQUENCY BAND	LIMIT
5.150 ~ 5.250GHz	4dBm
5.250 ~ 5.350GHz	11dBm
5.470 ~ 5.725GHz	11dBm

4.5.2 TEST INSTRUMENTS

DESCRIPTION & MANUFACTURER	MODEL NO.	SERIAL NO.	CALIBRATED UNTIL
R&S SPECTRUM ANALYZER	FSP40	100040	Jun. 28, 2008

NOTE: The calibration interval of the above test instruments is 12 months and the calibrations are traceable to NML/ROC and NIST/USA.

4.5.3 TEST PROCEDURES

- a. The transmitter output was connected to the spectrum analyzer.
- b. Set RBW = 1MHz, VBW = 3MHz. The PPSD is the highest level found across the emission in any 1MHz band.

4.5.4 DEVIATION FROM TEST STANDARD

No deviation

4.5.5 TEST SETUP

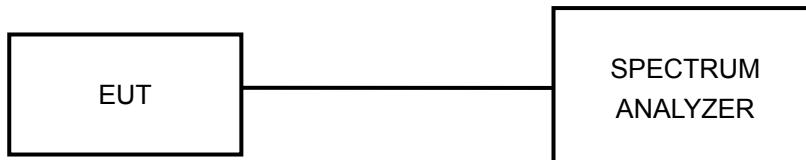

4.5.6 EUT OPERATING CONDITIONS

Same as 5.3.6

4.5.7 TEST RESULTS

802.11a OFDM MODULATION_NORMAL MODE:

MODULATION TYPE	BPSK	ENVIRONMENTAL CONDITIONS	23deg.C, 69%RH, 991hPa
INPUT POWER (SYSTEM)	120Vac, 60Hz	TESTED BY	Long Chen

CHANNEL	CHANNEL FREQUENCY (MHz)	RF POWER LEVEL IN 1MHz BW (dBm)	MAXIMUM LIMIT (dBm)	PASS / FAIL
1	5180	-1.35	2	PASS
2	5200	0.16	2	PASS
4	5240	0.38	2	PASS

NOTE: According to 15.407(a)(1)(2), the maximum antenna gain 8dBi is higher than 6dBi, so the limit of peak power shall be reduced by 2dB.

CH 1

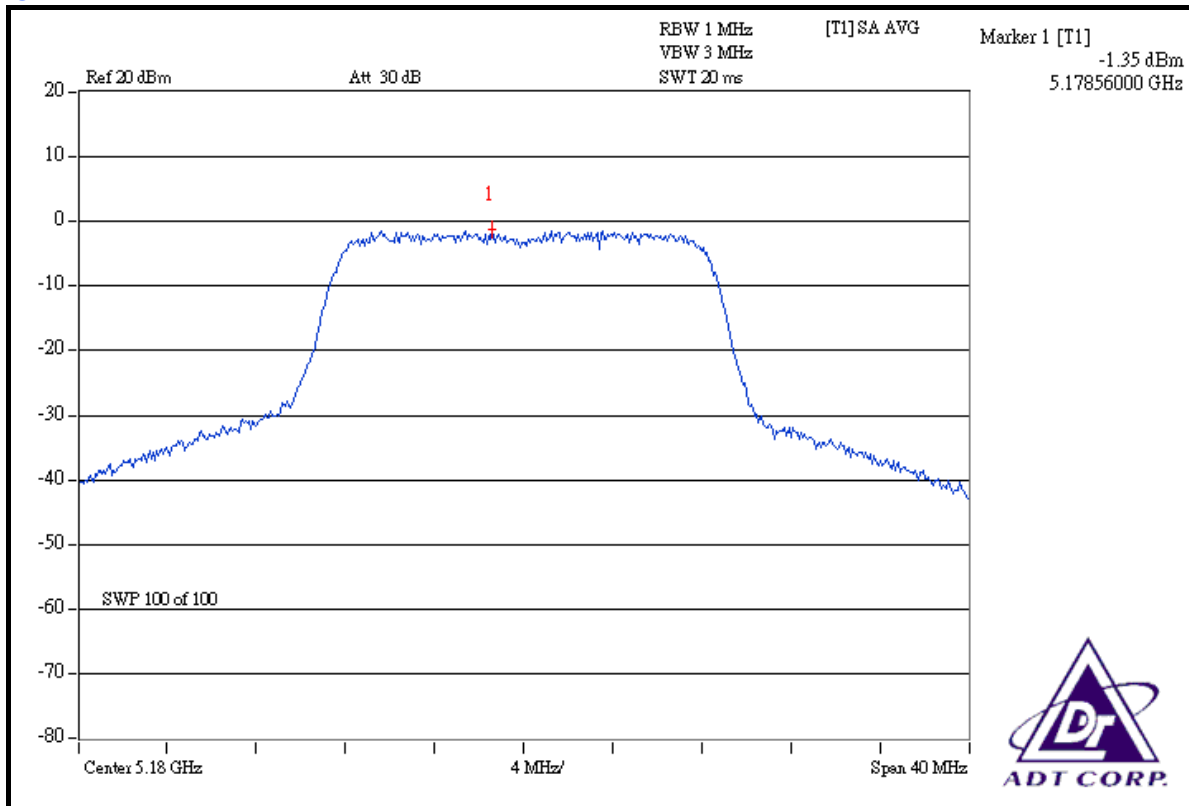



802.11a OFDM MODULATION_NORMAL MODE:

MODULATION TYPE	QPSK	ENVIRONMENTAL CONDITIONS	23deg.C, 69%RH, 991hPa
INPUT POWER (SYSTEM)	120Vac, 60Hz	TESTED BY	Long Chen

CHANNEL	CHANNEL FREQUENCY (MHz)	RF POWER LEVEL IN 1MHz BW (dBm)	MAXIMUM LIMIT (dBm)	PASS / FAIL
1	5210	-2.04	2	PASS

NOTE: According to 15.407(a)(1)(2), the maximum antenna gain 8dBi is higher than 6dBi, so the limit of peak power shall be reduced by 2dB.

CH 1

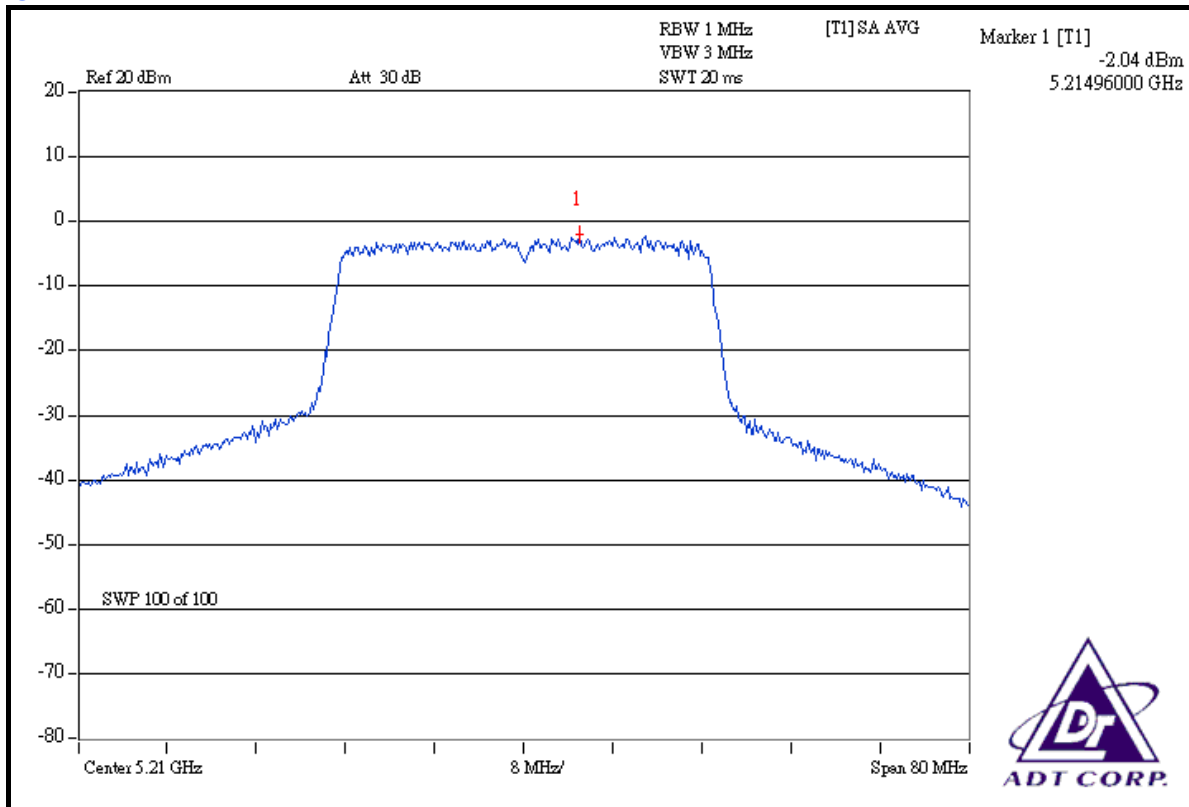

4.6 FREQUENCY STABILITY

4.6.1 LIMITS OF FREQUENCY STABILITY MEASUREMENT

The frequency tolerance of the carrier signal shall be maintained within +/- 0.02% of the operating frequency over a temperature variation of -30 degrees to 50 degrees C at normal supply voltage, and for a variation in the primary supply voltage from 85% to 115% of the rated supply voltage at a temperature of 20 degrees C.

4.6.2 TEST INSTRUMENTS

DESCRIPTION & MANUFACTURER	MODEL NO.	SERIAL NO.	CALIBRATED UNTIL
ANRITSU SPECTRUM ANALYZER	MS2667C	M10281	Mar. 07, 2008
WIT STANDARD TEMPERATURE AND HUMIDITY CHAMBER	TH-4S-C	W981030	Jun. 28, 2008

NOTE: The calibration interval of the above test instruments is 12 months and the calibrations are traceable to NML/ROC and NIST/USA.

4.6.3 TEST PROCEDURE

1. The EUT was placed inside the environmental test chamber and powered by nominal DC voltage.
2. Turn the EUT on and couple its output to a spectrum analyzer.
3. Turn the EUT off and set the chamber to the highest temperature specified.
4. Allow sufficient time (approximately 30 min) for the temperature of the chamber to stabilize, turn the EUT on and measure the operating frequency after 2, 5, and 10 minutes.
5. Repeat step 2 and 3 with the temperature chamber set to the lowest temperature.
6. The test chamber was allowed to stabilize at +20 degree C for a minimum of 30 minutes. The supply voltage was then adjusted on the EUT from 85% to 115% and the frequency record.

4.6.4 DEVIATION FROM TEST STANDARD

No deviation

4.6.5 TEST SETUP

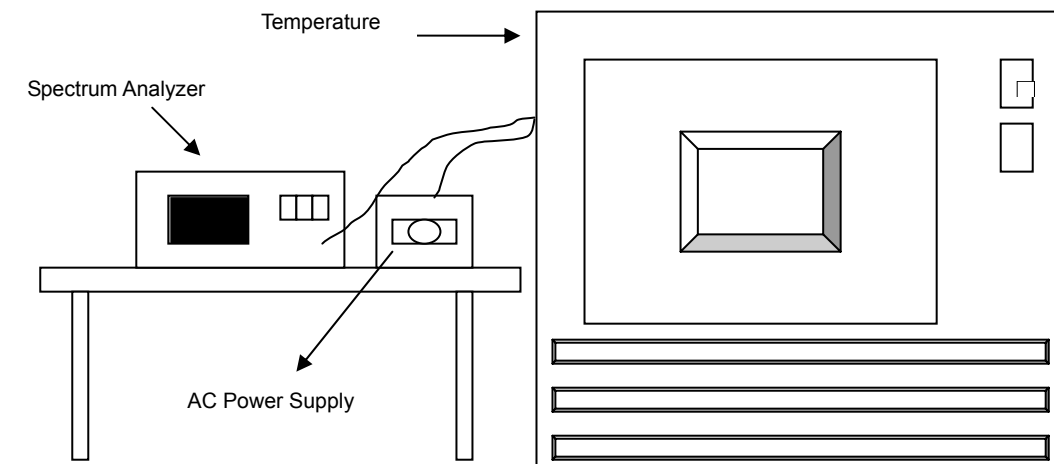

4.6.6 EUT OPERATING CONDITION

Same as Item 4.1.6



4.6.7 TEST RESULTS

OPERATING FREQUENCY: 5200MHz						LIMIT: ± 0.01%			
TEMP. (°C)	POWER SUPPLY (Vac)	0 MINUTE		2 MINUTE		5 MINUTE		10 MINUTE	
		(MHz)	(%)	(MHz)	(%)	(MHz)	(%)	(MHz)	(%)
50	126.5	5199.907731	-0.0017744	5199.917943	-0.0015780	5199.941154	-0.0011316	5199.938845	-0.0011760
	110.0	5199.923731	-0.0014667	5199.929943	-0.0013472	5199.944554	-0.0010663	5199.942745	-0.0011010
	93.5	5199.926531	-0.0014129	5199.930343	-0.0013396	5199.949754	-0.0009663	5199.949945	-0.0009626
40	126.5	5199.918831	-0.0015609	5199.926943	-0.0014049	5199.945554	-0.0010470	5199.943745	-0.0010818
	110.0	5199.925031	-0.0014417	5199.935743	-0.0012357	5199.950354	-0.0009547	5199.947845	-0.0010030
	93.5	5199.936631	-0.0012186	5199.943643	-0.0010838	5199.953254	-0.0008990	5199.954445	-0.0008760
30	126.5	5199.920131	-0.0015359	5199.933043	-0.0012876	5199.951254	-0.0009374	5199.949945	-0.0009626
	110.0	5199.925931	-0.0014244	5199.948643	-0.0009876	5199.958854	-0.0007913	5199.949945	-0.0009626
	93.5	5199.944031	-0.0010763	5199.957043	-0.0008261	5199.959954	-0.0007701	5199.960145	-0.0007664
20	126.5	5199.927131	-0.0014013	5199.936943	-0.0012126	5199.954554	-0.0008740	5199.955045	-0.0008645
	110.0	5199.927431	-0.0013956	5199.954343	-0.0008780	5199.962354	-0.0007240	5199.959445	-0.0007799
	93.5	5199.951731	-0.0009282	5199.965543	-0.0006626	5199.963854	-0.0006951	5199.962845	-0.0007145
10	126.5	5199.934331	-0.0012629	5199.947743	-0.0010049	5199.961954	-0.0007316	5199.961445	-0.0007414
	110.0	5199.942931	-0.0010975	5199.958643	-0.0007953	5199.964254	-0.0006874	5199.962845	-0.0007145
	93.5	5199.957831	-0.0008109	5199.970343	-0.0005703	5199.971954	-0.0005393	5199.972845	-0.0005222
0	126.5	5199.938031	-0.0011917	5199.954743	-0.0008703	5199.965554	-0.0006624	5199.966845	-0.0006376
	110.0	5199.949531	-0.0009706	5199.964143	-0.0006896	5199.972354	-0.0005316	5199.969945	-0.0005780
	93.5	5199.964131	-0.0006898	5199.973443	-0.0005107	5199.974354	-0.0004932	5199.975545	-0.0004703
-10	126.5	5199.950131	-0.0009590	5199.960243	-0.0007646	5199.972354	-0.0005316	5199.971745	-0.0005434
	110.0	5199.956631	-0.0008340	5199.970243	-0.0005722	5199.975554	-0.0004701	5199.976645	-0.0004491
	93.5	5199.971231	-0.0005532	5199.976643	-0.0004492	5199.979254	-0.0003990	5199.979945	-0.0003857
-20	126.5	5199.955031	-0.0008648	5199.966643	-0.0006415	5199.975854	-0.0004643	5199.976845	-0.0004453
	110.0	5199.960431	-0.0007609	5199.974643	-0.0004876	5199.982054	-0.0003451	5199.979845	-0.0003876
	93.5	5199.975231	-0.0004763	5199.984043	-0.0003069	5199.983254	-0.0003220	5199.980845	-0.0003684
-30	126.5	5199.960331	-0.0007629	5199.973443	-0.0005107	5199.982154	-0.0003432	5199.979245	-0.0003991
	110.0	5199.974731	-0.0004859	5199.979743	-0.0003896	5199.984554	-0.0002970	5199.983845	-0.0003107
	93.5	5199.977831	-0.0004263	5199.989243	-0.0002069	5199.988654	-0.0002182	5199.987045	-0.0002491



4.7 BAND EDGES MEASUREMENT

4.7.1 TEST INSTRUMENTS

Description & Manufacturer	Model No.	Serial No.	Calibrated Until
SPECTRUM ANALYZER	FSP40	100040	Jun. 28, 2008

NOTE: The calibration interval of the above test instruments is 12 months and the calibrations are traceable to NML/ROC and NIST/USA.

4.7.2 TEST PROCEDURE

The transmitter output was connected to the spectrum analyzer via a low loss cable. Set both RBW and VBW of spectrum analyzer to 1MHz / 3MHz with suitable frequency span including 100MHz bandwidth from band edge. The band edges was measured and recorded.

4.7.3 EUT OPERATING CONDITION

The software provided by client to enable the EUT under transmission condition continuously at specific channel frequencies individually.

4.7.4 TEST RESULTS

For signals in the restricted bands above and below the 5.15 to 5.35GHz allocated band a measurement was made of the amplitude of the spurious emissions with respect to the intentional signals. The relative amplitude, in dBc, was applied to the average and peak field strength of the intentional signal made on the OATS to calculate the field strength of the unintentional signals.

The spectrum plots (Peak RBW = 1MHz, VBW = 3MHz) are attached on the following pages.

802.11a OFDM MODULATION_NORMAL MODE:

TEST MODE B

Channel 1 (5180MHz)

The band edge emission plot on the next second page shows 41.50dBc between carrier maximum power and local maximum emission in restrict band. The emission of carrier strength list in the test result of channel 1 is 110.71dBuV/m (Peak), so the maximum field strength in restrict band is $110.71 - 41.50 = 69.21$ dBuV/m which is under 74dBuV/m limit.

The band edge emission plot on the next second page shows 51.19dBc between carrier maximum power and local maximum emission in restrict band. The emission of carrier strength list in the test result of channel 1 is 99.58dBuV/m (Average), so the maximum field strength in restrict band is $99.58 - 51.19 = 48.39$ dBuV/m which is under 54dBuV/m limit.

Channel 4 (5240MHz)

The band edge emission plot on the next third page shows 53.71dBc between carrier maximum power and local maximum emission in restrict band. The emission of carrier strength list in the test result of channel 4 is 111.93dBuV/m (Peak), so the maximum field strength in restrict band is $111.93 - 53.71 = 58.22$ dBuV/m which is under 74dBuV/m limit.

The band edge emission plot on the next fourth page shows 56.22dBc between carrier maximum power and local maximum emission in restrict band. The emission of carrier strength list in the test result of channel 4 is 100.99dBuV/m (Average), so the maximum field strength in restrict band is $100.99 - 56.22 = 44.77$ dBuV/m which is under 54dBuV/m limit.

TEST MODE E

Channel 1 (5180MHz)

The band edge emission plot on the next page shows 41.50dBc between carrier maximum power and local maximum emission in restrict band. The emission of carrier strength list in the test result of channel 1 is 114.19dBuV/m (Peak), so the maximum field strength in restrict band is $114.19 - 41.50 = 72.69$ dBuV/m which is under 74dBuV/m limit.

The band edge emission plot on the next page shows 51.19dBc between carrier maximum power and local maximum emission in restrict band. The emission of carrier strength list in the test result of channel 1 is 103.20dBuV/m (Average), so the maximum field strength in restrict band is $103.20 - 51.19 = 52.01$ dBuV/m which is under 54dBuV/m limit.

Channel 4 (5240MHz)

The band edge emission plot on the next second page shows 53.71dBc between carrier maximum power and local maximum emission in restrict band. The emission of carrier strength list in the test result of channel 4 is 116.66dBuV/m (Peak), so the maximum field strength in restrict band is $116.66 - 53.71 = 62.95$ dBuV/m which is under 74dBuV/m limit.

The band edge emission plot on the next third page shows 56.22dBc between carrier maximum power and local maximum emission in restrict band. The emission of carrier strength list in the test result of channel 4 is 105.30dBuV/m (Average), so the maximum field strength in restrict band is $105.30 - 56.22 = 49.08$ dBuV/m which is under 54dBuV/m limit.

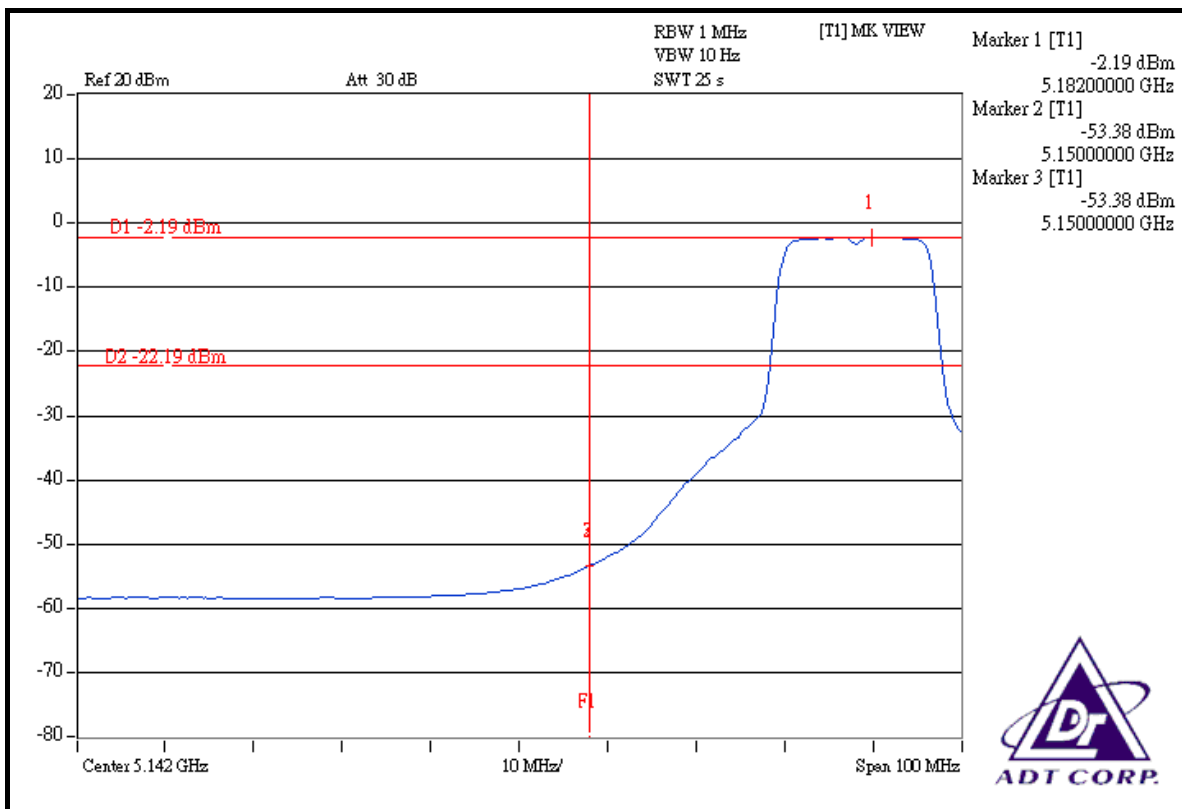
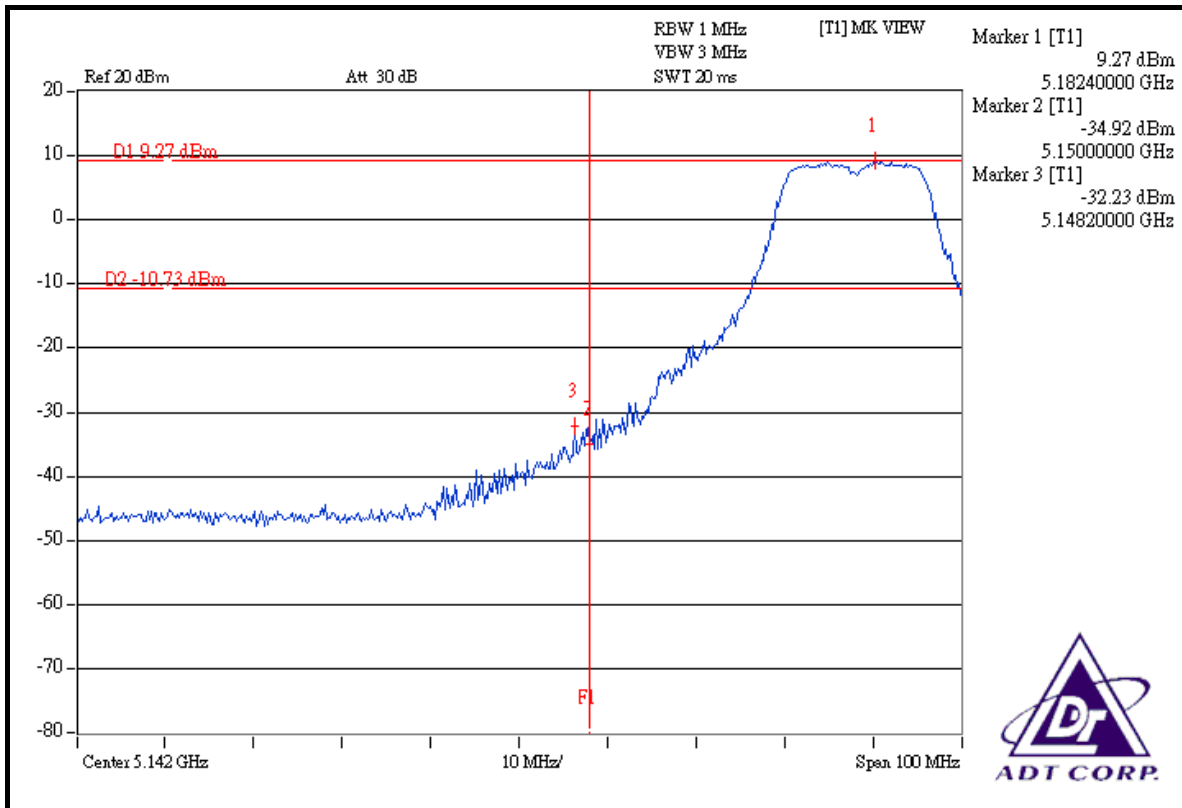

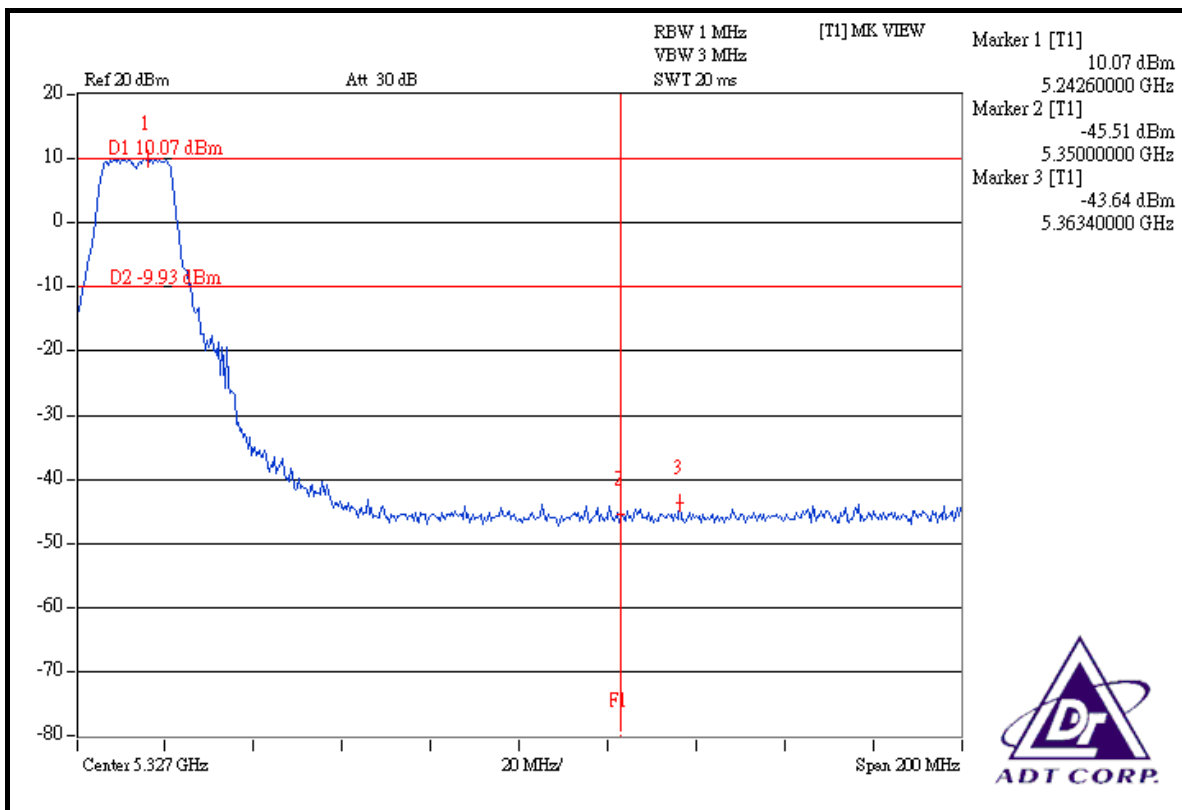
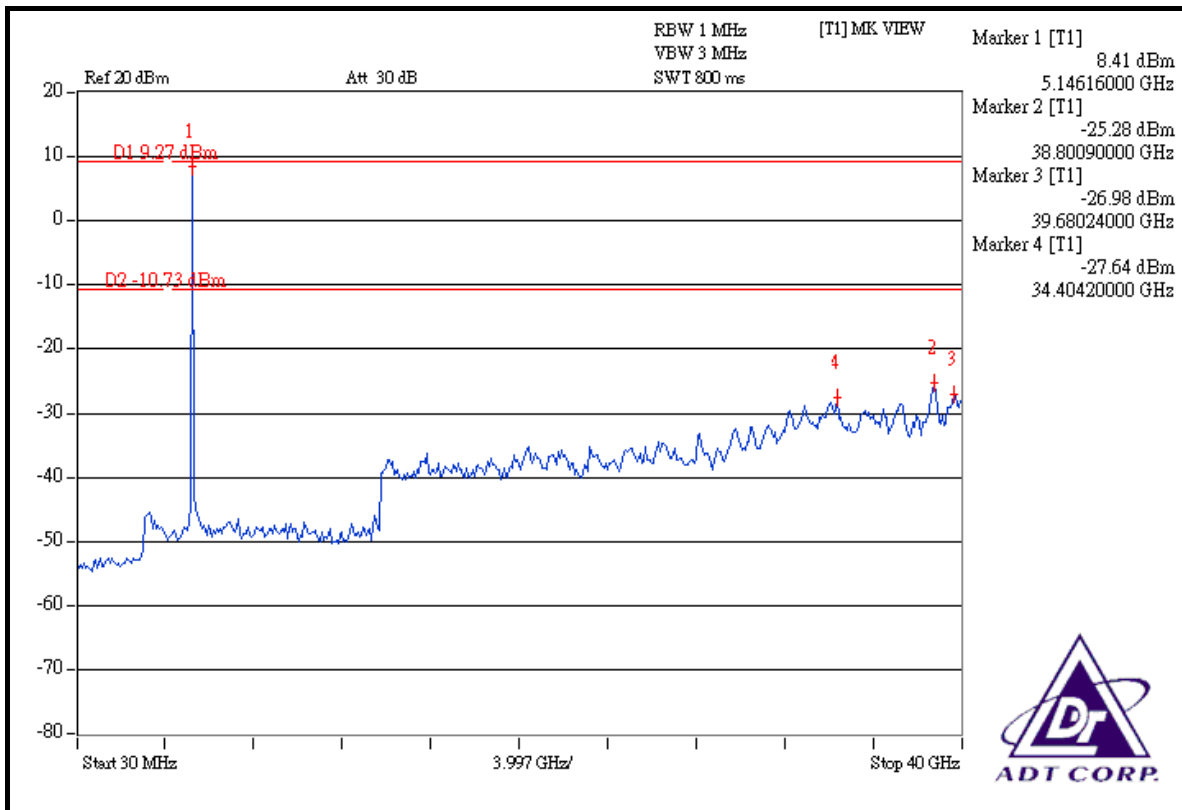

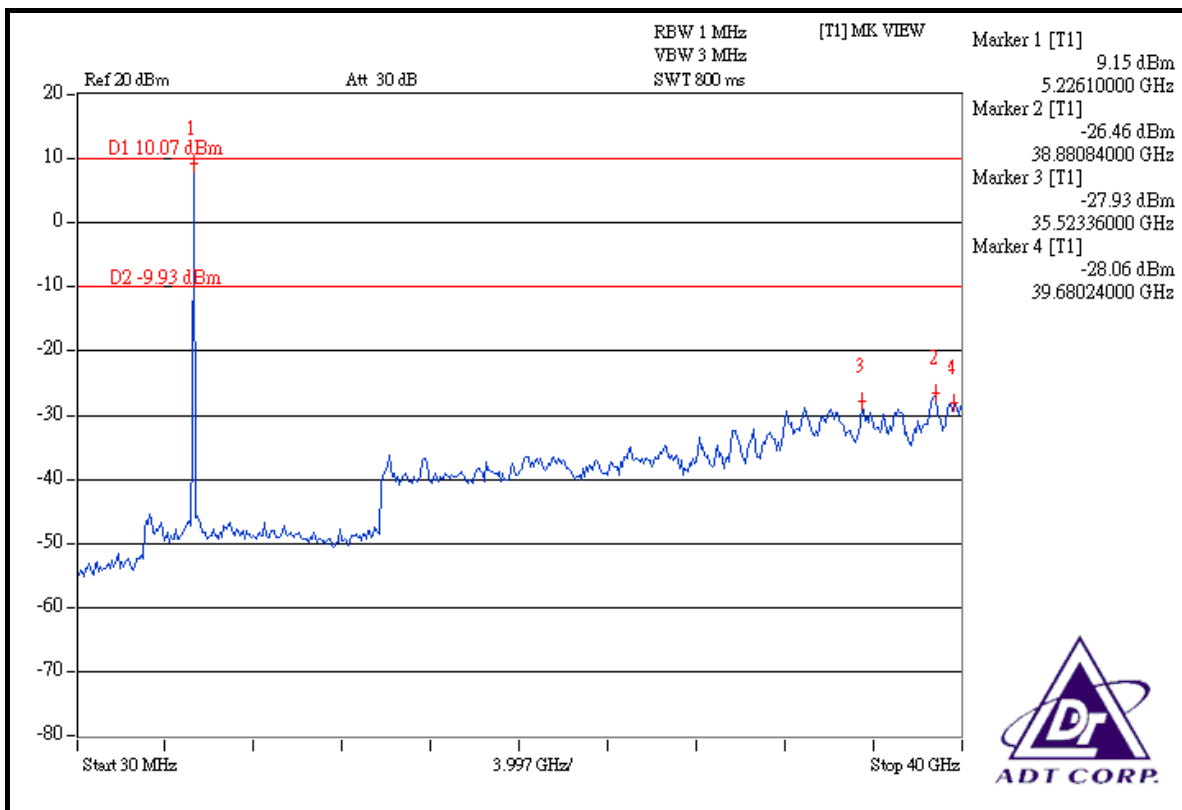
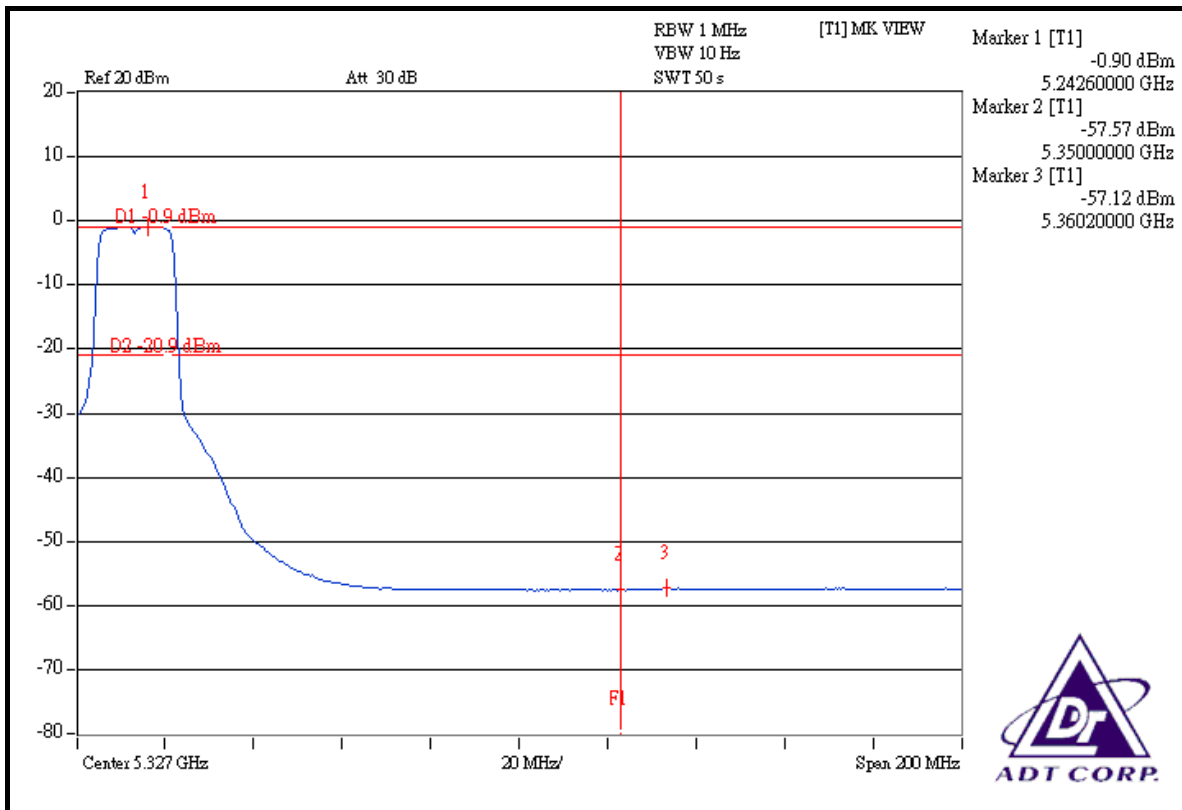

802.11a OFDM MODULATION_TURBO MODE:

TEST MODE B

Channel 1 (5120MHz)

The band edge emission plot on the next page shows 42.07dBc between carrier maximum power and local maximum emission in restrict band. The emission of carrier strength list in the test result of channel 1 is 108.31dBuV/m (Peak), so the maximum field strength in restrict band is $108.31 - 42.07 = 66.24$ dBuV/m which is under 74dBuV/m limit.

The band edge emission plot on the next page shows 49.55dBc between carrier maximum power and local maximum emission in restrict band. The emission of carrier strength list in the test result of channel 1 is 97.11dBuV/m (Average), so the maximum field strength in restrict band is $97.11 - 49.55 = 47.56$ dBuV/m which is under 54dBuV/m limit.

TEST MODE E

Channel 1 (5120MHz)

The band edge emission plot on the next page shows 42.07dBc between carrier maximum power and local maximum emission in restrict band. The emission of carrier strength list in the test result of channel 1 is 113.34dBuV/m (Peak), so the maximum field strength in restrict band is $113.34 - 42.07 = 71.27$ dBuV/m which is under 74dBuV/m limit.

The band edge emission plot on the next page shows 49.55dBc between carrier maximum power and local maximum emission in restrict band. The emission of carrier strength list in the test result of channel 1 is 102.21dBuV/m (Average), so the maximum field strength in restrict band is $102.21 - 49.55 = 52.66$ dBuV/m which is under 54dBuV/m limit.

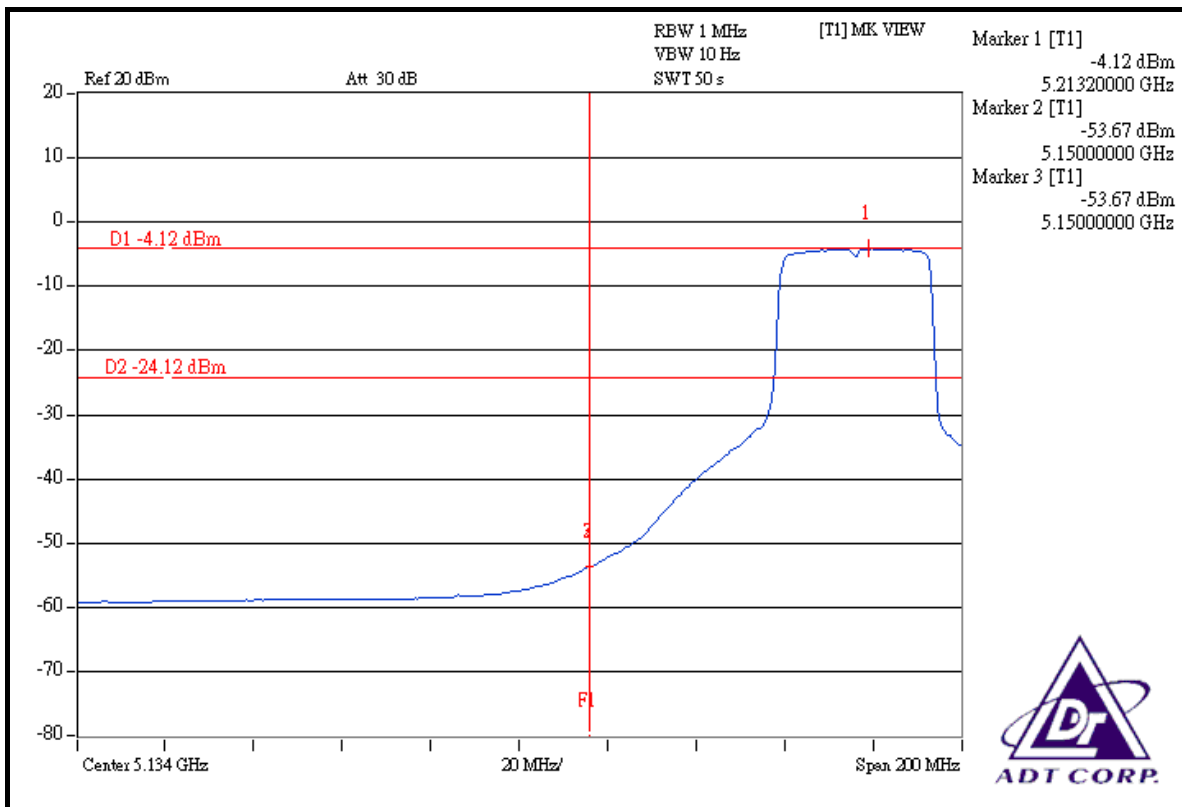
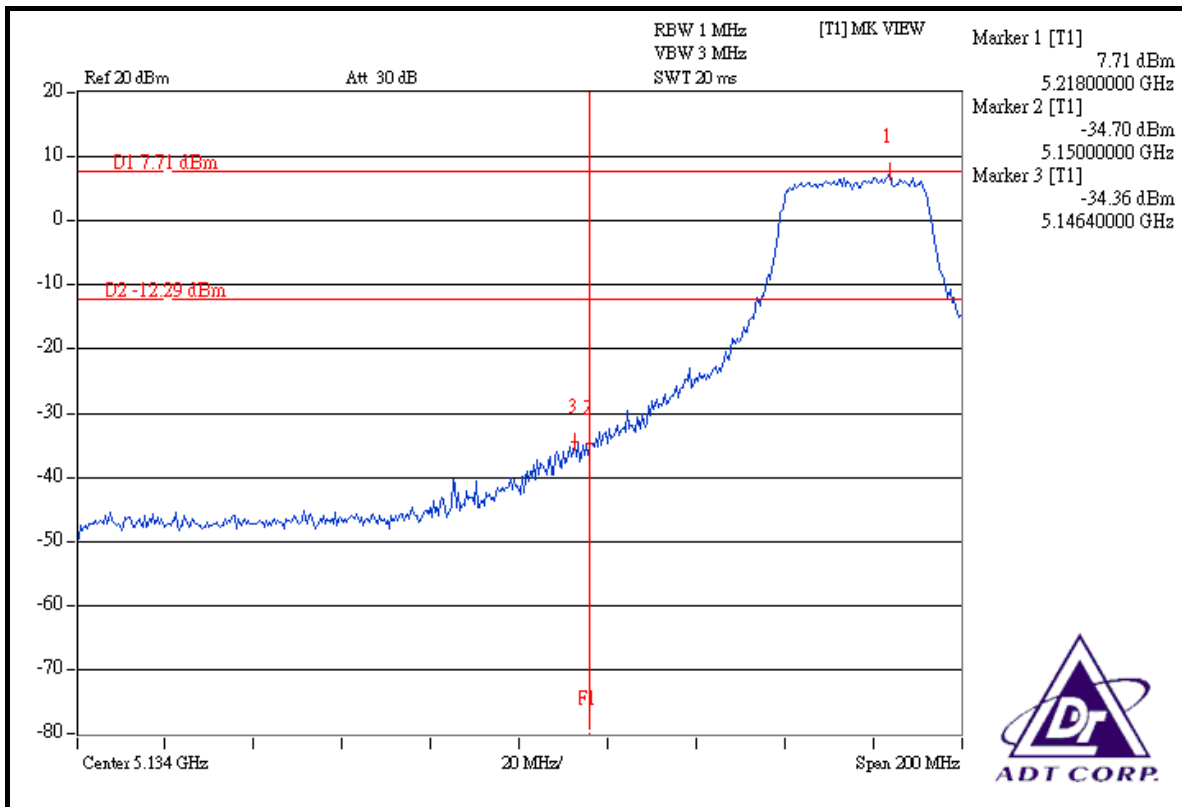

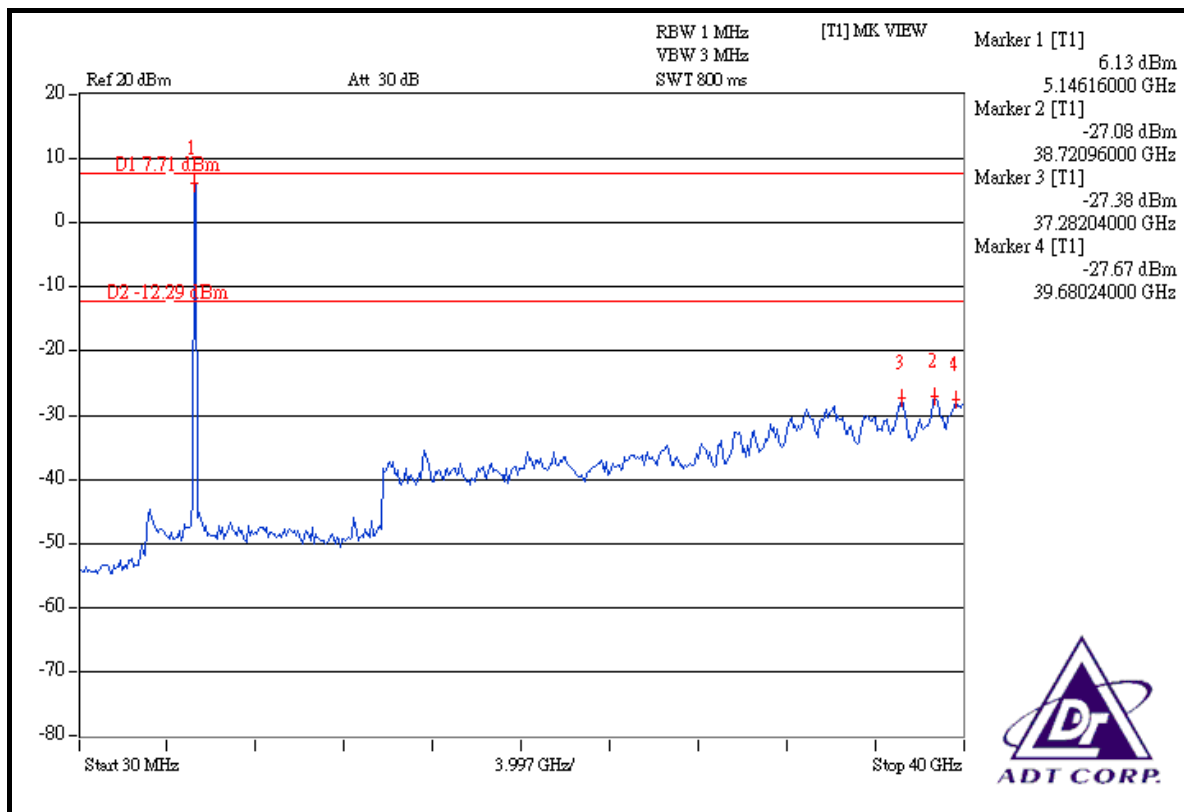

4.8 ANTENNA REQUIREMENT

4.8.1 STANDARD APPLICABLE

For intentional device, according to FCC 47 CFR Section 15.203, an intentional radiator shall be designed to ensure that no antenna other than that furnished by the responsible party shall be used with the device.

And according to FCC 47 CFR Section 15.407(a), if transmitting antennas of directional gain greater than 6dBi are used, the power shall be reduced by the amount in dB that the directional gain of the antenna exceeds 6dBi.

4.8.2 ANTENNA CONNECTED CONSTRUCTION

The antennas used in this product are Dipole Antenna with Reverse SMA connector & Printed Antenna with RP SMA Plug connector.
The maximum Gain of the antenna is 8.0dBi.



5. PHOTOGRAPHS OF THE TEST CONFIGURATION

Please refer to the attached file (Test Setup Photo).



6. INFORMATION ON THE TESTING LABORATORIES

We, ADT Corp., were founded in 1988 to provide our best service in EMC, Radio, Telecom and Safety consultation. Our laboratories are accredited and approved by the following approval agencies according to ISO/IEC 17025.

USA	FCC, UL, A2LA
Germany	TUV Rheinland
Japan	VCCI
Norway	NEMKO
Canada	INDUSTRY CANADA , CSA
R.O.C.	TAF, BSMI, NCC
Netherlands	Telefication
Singapore	GOST-ASIA(MOU)
Russia	CERTIS(MOU)

Copies of accreditation certificates of our laboratories obtained from approval agencies can be downloaded from our web site:
www.adt.com.tw/index.5/phtml. If you have any comments, please feel free to contact us at the following:

Linko EMC/RF Lab:
Tel: 886-2-26052180
Fax: 886-2-26051924

Hsin Chu EMC/RF Lab:
Tel: 886-3-5935343
Fax: 886-3-5935342

Hwa Ya EMC/RF/Safety Telecom Lab:
Tel: 886-3-3183232
Fax: 886-3-3185050

Web Site: www.adt.com.tw

The address and road map of all our labs can be found in our web site also.

7. APPENDIX A - MODIFICATIONS RECORDERS FOR ENGINEERING CHANGES TO THE EUT BY THE LAB

No any modifications are made to the EUT by the lab during the test.