



FCC TEST REPORT

REPORT NO.: RF931028L12

MODEL NO.: WMIA-105A

RECEIVED: Oct. 21, 2004

TESTED: Nov. 03 ~ Nov. 11, 2004

APPLICANT: SparkLAN Communications, Inc.

ADDRESS: 3Fl., No. 246, Sec. 1, Neihu Road., Neihu Chiu,
Taipei, Taiwan 114, R.O.C

ISSUED BY: Advance Data Technology Corporation

LAB ADDRESS: No. 47, 14th Ling, Chia Pau Tsuen, Lin Kou
Hsiang 244, Taipei Hsien, Taiwan, R.O.C.

TEST LOCATION: No. 19, Hwa Ya 2nd Rd., Wen Hwa Tsuen,
Kwei Shan Hsiang, Taoyuan Hsien 333,
Taiwan, R.O.C.

This test report consists of 140 pages in total. It may be duplicated completely for legal use with the approval of the applicant. It should not be reproduced except in full, without the written approval of our laboratory. The client should not use it to claim product endorsement by CNLA, A2LA or any government agencies. The test results in the report only apply to the tested sample.



0528
ILAC MRA



No. 2177-01



Table of Contents

1.	CERTIFICATION	5
2.	SUMMARY OF TEST RESULTS	6
2.1	MEASUREMENT UNCERTAINTY.....	8
3.	GENERAL INFORMATION	9
3.1	GENERAL DESCRIPTION OF EUT	9
3.2	DESCRIPTION OF TEST MODES.....	10
3.3	GENERAL DESCRIPTION OF APPLIED STANDARDS.....	10
3.4	DESCRIPTION OF SUPPORT UNITS	11
3.5	CONFIGURATION OF SYSTEM UNDER TEST.....	11
4.	TEST TYPES AND RESULTS (FOR PART 802.11a).....	12
	FOR FREQUENCY 5.15~5.35GHz	12
4.1	CONDUCTED EMISSION MEASUREMENT	12
4.1.1	LIMITS OF CONDUCTED EMISSION MEASUREMENT	12
4.1.2	TEST INSTRUMENTS	12
4.1.3	TEST PROCEDURES	13
4.1.4	DEVIATION FROM TEST STANDARD	13
4.1.5	TEST SETUP	14
4.1.6	EUT OPERATING CONDITIONS	14
4.1.7	TEST RESULTS.....	15
4.2	RADIATED EMISSION MEASUREMENT	17
4.2.1	LIMITS OF RADIATED EMISSION MEASUREMENT	17
4.2.2	LIMITS OF UNWANTED EMISSION OUT OF THE RESTRICTED BANDS.....	18
4.2.3	TEST INSTRUMENTS	19
4.2.4	TEST PROCEDURES	20
4.2.5	DEVIATION FROM TEST STANDARD	20
4.2.6	TEST SETUP	21
4.2.7	EUT OPERATING CONDITIONS	21
4.2.8	TEST RESULTS.....	22
4.3	Peak transmit power MEASUREMENT	31
4.3.1	LIMITS OF PEAK TRANSMIT POWER MEASUREMENT	31
4.3.2	TEST INSTRUMENTS	31
4.3.3	TEST PROCEDURE	32
4.3.4	DEVIATION FROM TEST STANDARD	32
4.3.5	TEST SETUP	32
4.3.6	EUT OPERATING CONDITIONS	32
4.3.7	TEST RESULTS.....	33
4.4	PEAK POWER EXCURSION MEASUREMENT	49
4.4.1	LIMITS OF PEAK POWER EXCURSION MEASUREMENT	49



4.4.2	TEST INSTRUMENTS	49
4.4.3	TEST PROCEDURE	50
4.4.4	DEVIATION FROM TEST STANDARD	50
4.4.5	TEST SETUP	50
4.4.6	EUT OPERATING CONDITIONS	50
4.4.7	TEST RESULTS.....	51
4.5	PEAK POWER SPECTRAL DENSITY MEASUREMENT	60
4.5.1	LIMITS OF PEAK POWER SPECTRAL DENSITY MEASUREMENT	60
4.5.2	TEST INSTRUMENTS	60
4.5.3	TEST PROCEDURES	61
4.5.4	DEVIATION FROM TEST STANDARD	61
4.5.5	TEST SETUP	61
4.5.6	EUT OPERATING CONDITIONS	61
4.5.7	TEST RESULTS.....	62
4.6	FREQUENCY STABILITY.....	71
4.6.1	LIMITS OF FREQUENCY STABILITY MEASUREMENT	71
4.6.2	TEST INSTRUMENTS	71
4.6.3	TEST PROCEDURE	71
4.6.4	DEVIATION FROM TEST STANDARD	71
4.6.5	TEST SETUP	72
4.6.6	EUT OPERATING CONDITION.....	72
4.6.7	TEST RESULTS.....	73
4.7	BAND EDGES MEASUREMENT	74
4.7.1	TEST INSTRUMENTS	74
4.7.2	TEST PROCEDURE	74
4.7.3	EUT OPERATING CONDITION.....	74
4.7.4	TEST RESULTS.....	74
4.8	ANTENNA REQUIREMENT	88
4.8.1	STANDARD APPLICABLE	88
4.8.2	ANTENNA CONNECTED CONSTRUCTION.....	88
	FOR FREQUENCY 5.725~5.850GHz	89
4.9	6dB BANDWIDTH MEASUREMENT	105
4.9.1	LIMITS OF 6dB BANDWIDTH MEASUREMENT	105
4.9.2	TEST INSTRUMENTS	105
4.9.3	TEST PROCEDURE	106
4.9.4	DEVIATION FROM TEST STANDARD	106
4.9.5	TEST SETUP	106
4.9.6	EUT OPERATING CONDITIONS	106
4.9.7	TEST RESULTS.....	107
4.10	MAXIMUM PEAK OUTPUT POWER	114
4.10.1	LIMITS OF MAXIMUM PEAK OUTPUT POWER MEASUREMENT	114



4.10.2 INSTRUMENTS.....	114
4.10.3 TEST PROCEDURES	115
4.10.4 DEVIATION FROM TEST STANDARD	115
4.10.5 TEST SETUP	115
4.10.6 EUT OPERATING CONDITIONS	115
4.10.7 TEST RESULTS.....	116
4.11 POWER SPECTRAL DENSITY MEASUREMENT.....	117
4.11.1 LIMITS OF POWER SPECTRAL DENSITY MEASUREMENT.....	117
4.11.2 TEST INSTRUMENTS	117
4.11.3 TEST PROCEDURE.....	118
4.11.4 DEVIATION FROM TEST STANDARD	118
4.11.5 TEST SETUP	118
4.11.6 EUT OPERATING CONDITION.....	118
4.11.7 TEST RESULTS.....	119
4.12 BAND EDGES MEASUREMENT.....	126
4.12.1 LIMITS OF BAND EDGES MEASUREMENT.....	126
4.12.2 TEST INSTRUMENTS.....	126
4.12.3 TEST PROCEDURE.....	126
4.12.4 DEVIATION FROM TEST STANDARD	126
4.12.5 EUT OPERATING CONDITION.....	127
4.12.6 TEST RESULTS.....	127
4.13 ANTENNA REQUIREMENT.....	136
4.13.1 STANDARD APPLICABLE.....	136
4.13.2 ANTENNA CONNECTED CONSTRUCTION.....	136
5. PHOTOGRAPHS OF THE TEST CONFIGURATION.....	137
6. INFORMATION ON THE TESTING LABORATORIES.....	140



1. CERTIFICATION

PRODUCT: 802.11a mini-PCI Module
BRAND NAME: SparkLAN
MODEL NO.: WMIA-105A
TESTED: Nov. 03 ~ Nov. 11, 2004
APPLICANT: SparkLAN Communications, Inc.
TEST SAMPLE: Engineering Sample
STANDARDS: FCC Part 15, Subpart C (Section 15.247),
Subpart E (Section 15.407), ANSI C63.4-2003

The above equipment have been tested by **Advance Data Technology Corporation**, and found compliance with the requirement of the above standards. The test record, data evaluation & Equipment Under Test (EUT) configurations represented herein are true and accurate accounts of the measurements of the sample's EMC characteristics under the conditions specified in this report.

PREPARED BY : Candice Chen , **DATE:** Nov. 15, 2004
(Candice Chen)

TECHNICAL
ACCEPTANCE : Gary Chang , **DATE:** Nov. 15, 2004
Responsible for RF (Gary Chang)

APPROVED BY : Cody Chang , **DATE:** Nov. 15, 2004
(Cody Chang, Deputy
Manager)



2. SUMMARY OF TEST RESULTS

The EUT has been tested according to the following specifications:

For Freq. 5.15 ~ 5.35GHz:

APPLIED STANDARD: FCC Part 15, Subpart E			
Standard Section	Test Type	Result	Remark
15.407(b)(5)	AC Power Conducted Emission	PASS	Meet the requirement of limit. Minimum passing margin is -16.69dB at 0.240MHz
15.407(b/1/2/3) (b)(5)	Electric Field Strength Spurious Emissions, 30MHz ~ 40000MHz	PASS	Meet the requirement of limit. Minimum passing margin is -1.31dB at 10480.00MHz
15.407(a/1/2/3)	Peak Transmit Power	PASS	Meet the requirement of limit.
15.407(a)(6)	Peak Power Excursion	PASS	Meet the requirement of limit.
15.407(a/1/2/3)	Peak Power Spectral Density	PASS	Meet the requirement of limit.
15.407(g)	Frequency Stability	PASS	Meet the requirement of limit.



For Freq. 5.725 ~ 5.850GHz :

APPLIED STANDARD: FCC Part 15, Subpart C			
Standard Section	Test Type and Limit	Result	Remark
15.207	AC Power Conducted Emission	PASS	Meet the requirement of limit. Minimum passing margin is -16.69dB at 0.240MHz
15.247(a)(2)	Spectrum Bandwidth of a Direct Sequence Spread Spectrum System Limit: min. 500kHz	PASS	Meet the requirement of limit.
15.247(b)	Maximum Peak Output Power Limit: max. 30dBm	PASS	Meet the requirement of limit.
15.247(d)	Radiated Emissions Limit: Table 15.209	PASS	Meet the requirement of limit. Minimum passing margin is -2.55dB at 199.12MHz
15.247(e)	Power Spectral Density Limit: max. 8dBm	PASS	Meet the requirement of limit.
15.247(d)	Band Edge Measurement Limit: 20dB less than the peak value of fundamental frequency	PASS	Meet the requirement of limit.



2.1 MEASUREMENT UNCERTAINTY

Where relevant, the following measurement uncertainty levels have been estimated for tests performed on the EUT as specified in CISPR 16-4:

Measurement	Frequency	Uncertainty
Conducted emissions	9kHz~30MHz	2.44 dB
Radiated emissions	30MHz ~ 200MHz	3.73 dB
	200MHz ~ 1000MHz	3.74 dB
	1GHz ~ 18GHz	2.20 dB
	18GHz ~ 40GHz	1.88 dB



3. GENERAL INFORMATION

3.1 GENERAL DESCRIPTION OF EUT

EUT	802.11a mini-PCI Module
MODEL NO.	WMIA-105A
POWER SUPPLY	3.3Vdc from host equipment
MODULATION TYPE	64QAM, 16QAM, QPSK, BPSK for OFDM
MODULATION TECHNOLOGY	OFDM
TRANSFER RATE	54/48/36/24/18/12/9/6Mbps (Turbo mode: up to 108Mbps *see Note 2)
FREQUENCY RANGE	5.15 ~ 5.35GHz and 5.725 ~ 5.850GHz
NUMBER OF CHANNEL	13 for Normal mode / 5 for Turbo mode
CHANNEL SPACING	20MHz for Normal mode / 40MHz for Turbo mode
OUTPUT POWER	25.645mW
DATA CABLE	NA
ANTENNA TYPE	Printed antenna with 2.7dBi gain
I/O PORTS	NA
ASSOCIATED DEVICES	NA

NOTE:

1. The EUT operates in the 5GHz Bands and compatibility with 802.11a technology.
2. This EUT is capable of providing data rates of up to 108Mbps in Turbo Mode depending upon reception quality.
3. The above EUT information was declared by the manufacturer and for more detailed features description, please refer to the manufacturer's specifications or User's Manual.



3.2 DESCRIPTION OF TEST MODES

Thirteen channels are provided to this EUT for Normal mode.

Channel	Frequency	Channel	Frequency
1	5180 MHz	8	5320 MHz
2	5200 MHz	9	5745 MHz
3	5220 MHz	10	5765 MHz
4	5240 MHz	11	5785 MHz
5	5260 MHz	12	5805 MHz
6	5280 MHz	13	5825 MHz
7	5300 MHz		

Five channels are provided to this EUT for Turbo Mode.

Channel	Frequency	Channel	Frequency
1	5210 MHz	4	5760 MHz
2	5250 MHz	5	5800 MHz
3	5290 MHz		

NOTE:

1. The EUT was tested in both normal mode (channel bandwidth of approximately 30MHz) and turbo mode (channel bandwidth of approximately 60MHz).
2. "Normal Mode" allows data rates of up to 54Mbps, and "Turbo Mode" allows data rates of up to 108Mbps. After pre-tested all data rates, we have chosen 6Mbps for normal mode and 12Mbps for turbo mode, as the worst cases for the test among other data rates.
3. Channel 1, 4, 5, 8, 9, 11 and 13 are the closest frequencies to the band edge, were chosen for final test of Normal Mode.
4. Channel 1~5 were chosen for final test of Turbo mode.
5. Below 1GHz test, channel 1 ~ 13 for normal mode and channel 1 ~ 5 for turbo mode were pre-tested in chamber. Channel 5 with normal mode, worst case one, was chosen for final test and recorded in the report.
6. For conducted emission test, we have chosen normal mode as the worst case after pre-testing in conducted emission test site.

3.3 GENERAL DESCRIPTION OF APPLIED STANDARDS

The EUT is a 802.11a mini-PCI Module. According to the specifications of the manufacturer, it must comply with the requirements of the following standards:

**FCC Part 15, Subpart C. (15.247),
Subpart E (15.407). ANSI C63.4 : 2003**

All test items have been performed and recorded as per the above standards.

NOTE: The EUT is also considered as a kind of computer peripheral, because the connection to computer is necessary for typical use. It has been verified to comply with the requirements of FCC Part 15, Subpart B, Class B (DoC). The test report has been issued separately.



3.4 DESCRIPTION OF SUPPORT UNITS

The EUT has been tested as an independent unit together with other necessary accessories or support units. The following support units or accessories were used to form a representative test configuration during the tests.

NO.	PRODUCT	BRAND	MODEL NO.	SERIAL NO.	FCC ID
1	NOTEBOOK COMPUTER	DELL	PP05L	33898721680	E2K24CLNS
2	PRINTER	EPSON	LQ-300+	DCGY054147	FCC DoC Approved
3	MODEM	ACEEX	1414V/3	0401008269	IFAXDM1414

NO.	SIGNAL CABLE DESCRIPTION OF THE ABOVE SUPPORT UNITS
1	NA
2	1.2m braid shielded wire, terminated with DB25 and Centronics connector via metallic frame, w/o core
3	1.2 m braid shielded wire, terminated with DB25 and DB9 connector via metallic frame, w/o core.

NOTE: All power cords of the above support units are non shielded (1.8m).

3.5 CONFIGURATION OF SYSTEM UNDER TEST

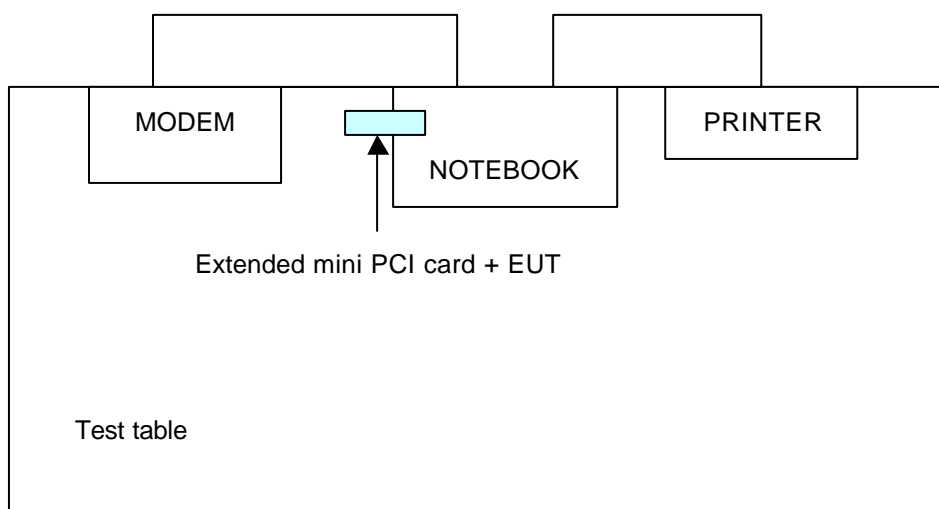



4. TEST TYPES AND RESULTS (FOR PART 802.11a)

FOR FREQUENCY 5.15~5.35GHz

4.1 CONDUCTED EMISSION MEASUREMENT

4.1.1 LIMITS OF CONDUCTED EMISSION MEASUREMENT

FREQUENCY OF EMISSION (MHz)	CONDUCTED LIMIT (dB μ V)	
	Quasi-peak	Average
0.15-0.5	66 to 56	56 to 46
0.5-5	56	46
5-30	60	50

- NOTE:**
1. The lower limit shall apply at the transition frequencies.
 2. The limit decreases in line with the logarithm of the frequency in the range of 0.15 to 0.50 MHz.
 3. All emanations from a class A/B digital device or system, including any network of conductors and apparatus connected thereto, shall not exceed the level of field strengths specified above.

4.1.2 TEST INSTRUMENTS

DESCRIPTION & MANUFACTURER	MODEL NO.	SERIAL NO.	CALIBRATED UNTIL
Test Receiver ROHDE & SCHWARZ	ESCS30	100291	Nov. 16, 2005
RF signal cable Woken	5D-FB	Cable-HYC01-01	Mar. 02, 2005
LISN ROHDE & SCHWARZ	ESH3-Z5	100312	Mar. 03, 2005
LISN ROHDE & SCHWARZ	ESH2-Z5	100104	Mar. 02, 2005
Software ADT	ADT_Cond_V3	NA	NA

- NOTE:**
1. The calibration interval of the above test instruments is 12 months and the calibrations are traceable to NML/ROC and NIST/USA.
 2. The test was performed in HwaYa Shielded Room 1.
 3. The VCCI Site Registration No. is C-2040.



4.1.3 TEST PROCEDURES

- a. The EUT was placed 0.4 meters from the conducting wall of the shielded room with EUT being connected to the power mains through a line impedance stabilization network (LISN). Other support units were connected to the power mains through another LISN. The two LISNs provide 50 ohm/ 50uH of coupling impedance for the measuring instrument.
- b. Both lines of the power mains connected to the EUT were checked for maximum conducted interference.
- c. The frequency range from 150kHz to 30MHz was searched. Emission levels under (Limit - 20dB) was not recorded.

4.1.4 DEVIATION FROM TEST STANDARD

No deviation

4.1.5 TEST SETUP

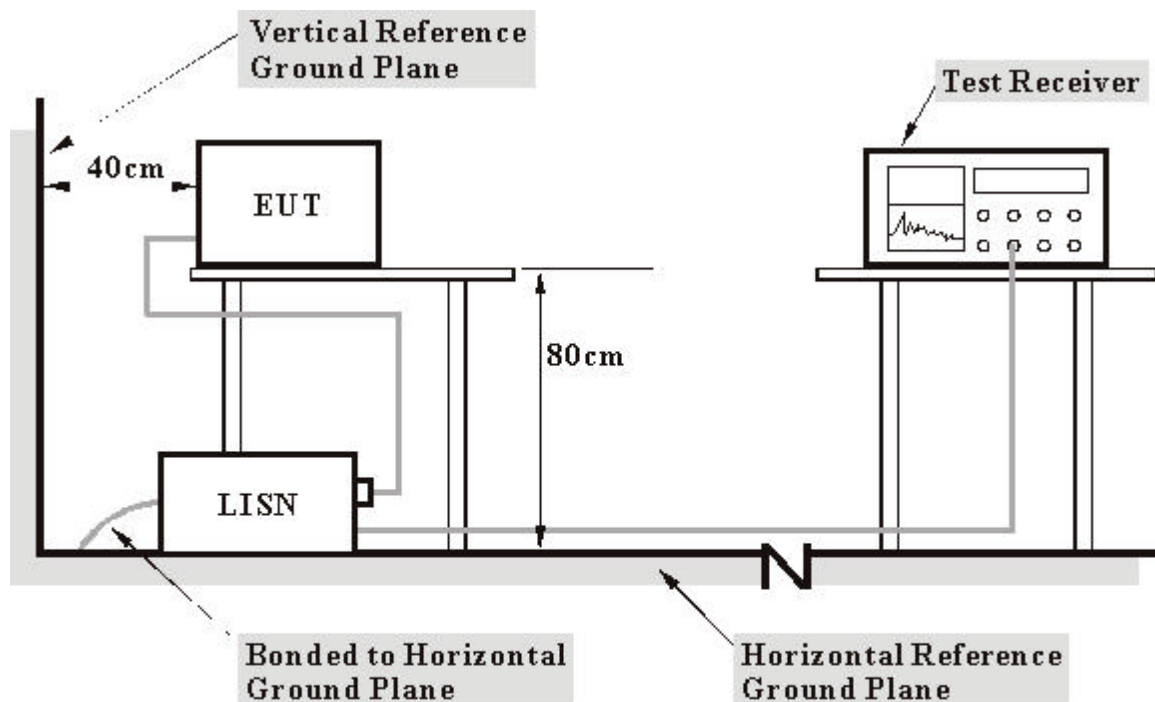

- Note:**
1. Support units were connected to second LISN.
 2. Both of LISNs (AMN) 80 cm from EUT and at the least 80 cm from other units and other metal planes support units.

For the actual test configuration, please refer to the related item – Photographs of the Test Configuration.

4.1.6 EUT OPERATING CONDITIONS

- a. Connected the EUT to a notebook system placed on a testing table.
- b. The notebook system ran a test program (provided by manufacturer) to enable EUT under transmission/receiving condition continuously at specific channel frequency.
- c. The notebook system sent "H" messages to its screen.
- d. The notebook system sent "H" messages to modem.
- e. The notebook system sent "H" messages to printer, and the printer prints them on paper.
- f. Steps c-e are repeated.



4.1.7 TEST RESULTS

EUT	802.11a mini-PCI Module	MODEL	WMIA-105A
		6dB BANDWIDTH	9 kHz
INPUT POWER (SYSTEM)	120Vac, 60 Hz	PHASE	Line (L)
ENVIRONMENTAL CONDITIONS	24deg. C, 65%RH, 991hPa	TESTED BY: Steven Lu	

No	Freq. [MHz]	Corr. Factor (dB)	Reading Value		Emission Level		Limit		Margin	
			[dB (uV)]		[dB (uV)]		[dB (uV)]		(dB)	
			Q.P.	AV.	Q.P.	AV.	Q.P.	AV.	Q.P.	AV.
1	0.154	0.11	39.99	-	40.10	-	65.79	55.79	-25.69	-
2	0.240	0.12	45.29	-	45.41	-	62.10	52.10	-16.69	-
3	0.306	0.12	32.94	-	33.06	-	60.07	50.07	-27.01	-
4	1.629	0.16	30.32	-	30.48	-	56.00	46.00	-25.52	-
5	2.113	0.16	28.98	-	29.14	-	56.00	46.00	-26.86	-
6	10.176	0.32	29.56	-	29.88	-	60.00	50.00	-30.12	-

- REMARKS:**
1. Q.P. and AV. are abbreviations of quasi-peak and average individually.
 2. "-": The Quasi-peak reading value also meets average limit and measurement with the average detector is unnecessary.
 3. The emission levels of other frequencies were very low against the limit.
 4. Margin value = Emission level - Limit value
 5. Correction factor = Insertion loss + Cable loss
 6. Emission Level = Correction Factor + Reading Value.

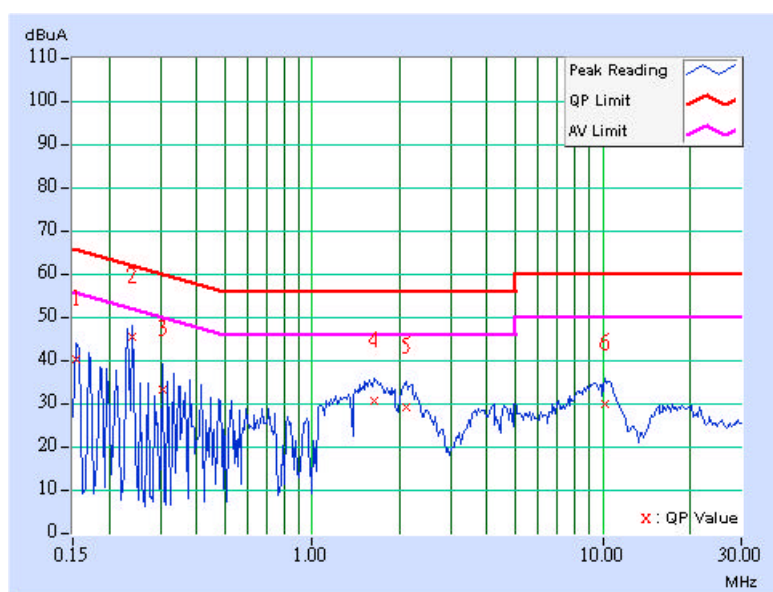



EUT	802.11a mini-PCI Module	MODEL	WMIA-105A
		6dB BANDWIDTH	9 kHz
INPUT POWER (SYSTEM)	120Vac, 60 Hz	PHASE	Neutral (N)
ENVIRONMENTAL CONDITIONS	24deg. C, 65%RH, 991hPa	TESTED BY: Steven Lu	

No	Freq. [MHz]	Corr. Factor (dB)	Reading Value [dB (uV)]		Emission Level [dB (uV)]		Limit [dB (uV)]		Margin (dB)	
			Q.P.	AV.	Q.P.	AV.	Q.P.	AV.	Q.P.	AV.
	1	0.177	0.11	44.70	-	44.81	-	64.61	54.61	-19.80
2	0.240	0.11	44.37	-	44.48	-	62.10	52.10	-17.62	-
3	0.351	0.12	30.92	-	31.04	-	58.94	48.94	-27.91	-
4	1.840	0.16	31.34	-	31.50	-	56.00	46.00	-24.50	-
5	4.816	0.22	21.94	-	22.16	-	56.00	46.00	-33.84	-
6	10.277	0.30	29.98	-	30.28	-	60.00	50.00	-29.72	-

- REMARKS:**
1. Q.P. and AV. are abbreviations of quasi-peak and average individually.
 2. "-": The Quasi-peak reading value also meets average limit and measurement with the average detector is unnecessary.
 3. The emission levels of other frequencies were very low against the limit.
 4. Margin value = Emission level - Limit value
 5. Correction factor = Insertion loss + Cable loss
 6. Emission Level = Correction Factor + Reading Value.

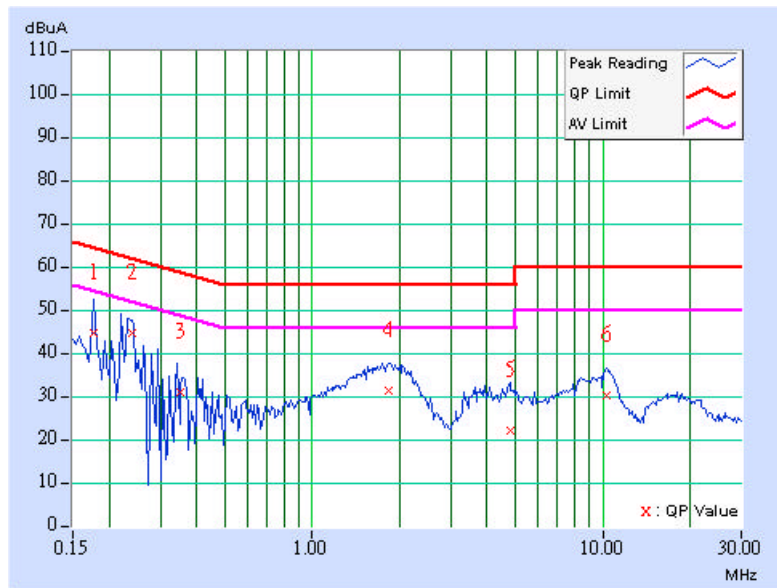



4.2 RADIATED EMISSION MEASUREMENT

4.2.1 LIMITS OF RADIATED EMISSION MEASUREMENT

Emissions radiated outside of the specified bands, shall be according to the general radiated limits in 15.209 as following:

Frequencies (MHz)	Field strength (microvolts/meter)	Measurement distance (meters)
0.009-0.490	2400/F(kHz)	300
0.490-1.705	24000/F(kHz)	30
1.705-30.0	30	30
30-88	100	3
88-216	150	3
216-960	200	3
Above 960	500	3

NOTE

1. The lower limit shall apply at the transition frequencies.
2. Emission level (dBuV/m) = 20 log Emission level (uV/m).
3. As shown in 15.35(b), for frequencies above 1000MHz, the field strength limits are based on average detector, however, the peak field strength of any emission shall not exceed the maximum permitted average limits, specified above by more than 20dB under any condition of modulation.



4.2.2 LIMITS OF UNWANTED EMISSION OUT OF THE RESTRICTED BANDS

Frequencies (MHz)	EIRP Limit (dBm)	Equivalent Field Strength at 3m (dB μ V/m) *note 3
5150~5250	-27	68.3
5250~5350	-27	68.3
5725~5825	-27 *note 1	68.3
	-17 *note 2	78.3

NOTE:

1. For frequencies 10MHz or greater above or below the band edge.
2. All emissions within the frequency range from the band edge to 10MHz above or below the band edge.
3. The following formula is used to convert the equipment isotropic radiated power (eirp) to field strength

$$E = \frac{1000000\sqrt{30P}}{3} \quad \mu\text{V/m, where P is the eirp (Watts)}$$



4.2.3 TEST INSTRUMENTS

DESCRIPTION & MANUFACTURER	MODEL NO.	SERIAL NO.	CALIBRATED UNTIL
Test Receiver ROHDE & SCHWARZ	ESIB7	100188	Jan. 13, 2005
Spectrum Analyzer ROHDE & SCHWARZ	FSP40	100039	Dec. 15, 2004
BILOG Antenna SCHWARZBECK	VULB9168	9168-157	Feb. 03, 2005
HORN Antenna SCHWARZBECK	BBHA 9120 D	9120D-407	Feb. 03, 2005
HORN Antenna SCHWARZBECK	BBHA 9170	BBHA 9170241	Feb. 23, 2005
Preamplifier Agilent	8449B	3008A01961	Nov. 09, 2005
Preamplifier Agilent	8447D	2944A10629	Nov. 09, 2005
RF signal cable HUBER+SUHNER	SUCOFLEX 104	218182/4	Mar. 04, 2005
RF signal cable HUBER+SUHNER	SUCOFLEX 104	218194/4	Mar. 04, 2005
Software ADT.	ADT_Radiated_V5.14	NA	NA
Antenna Tower ADT.	AT100	AT93021702	NA
Turn Table ADT.	TT100.	TT93021702	NA
Controller ADT.	SC100.	SC93021702	NA

- NOTE:**
1. The calibration interval of the above test instruments is 12 months and the calibrations are traceable to NML/ROC and NIST/USA.
 2. The test was performed in HwaYa Chamber 1.
 3. The horn antenna and HP preamplifier (model: 8449B) are used only for the measurement of emission frequency above 1GHz if tested.
 4. The IC Site Registration No. is IC4924-2.



4.2.4 TEST PROCEDURES

- a. The EUT was placed on the top of a rotating table 0.8 meters above the ground at a 3 meter semi-anechoic chamber. The table was rotated 360 degrees to determine the position of the highest radiation.
- b. The EUT was set 3 meters away from the interference-receiving antenna, which was mounted on the top of a variable-height antenna tower.
- c. The antenna is a broadband antenna, and its height is varied from one meter to four meters above the ground to determine the maximum value of the field strength. Both horizontal and vertical polarizations of the antenna are set to make the measurement.
- d. For each suspected emission, the EUT was arranged to its worst case and then the antenna was tuned to heights from 1 meter to 4 meters and the rotatable table was turned from 0 degrees to 360 degrees to find the maximum reading.
- e. The test-receiver system was set to Peak Detect Function and Specified Bandwidth with Maximum Hold Mode.
- f. If the emission level of the EUT in peak mode was 10dB lower than the limit specified, then testing could be stopped and the peak values of the EUT would be reported. Otherwise the emissions that did not have 10dB margin would be re-tested one by one using peak, quasi-peak or average method as specified and then reported in a data sheet.

NOTE:

1. The resolution bandwidth and video bandwidth of test receiver/spectrum analyzer is 120kHz for Peak detection (PK) and Quasi-peak detection (QP) at frequency below 1GHz.
2. The resolution bandwidth and video bandwidth of test receiver/spectrum analyzer is 1 MHz for Peak detection at frequency above 1GHz.
3. The resolution bandwidth of test receiver/spectrum analyzer is 1 MHz and the video bandwidth is 10 Hz for Average detection (AV) at frequency above 1GHz.

4.2.5 DEVIATION FROM TEST STANDARD

No deviation

4.2.6 TEST SETUP

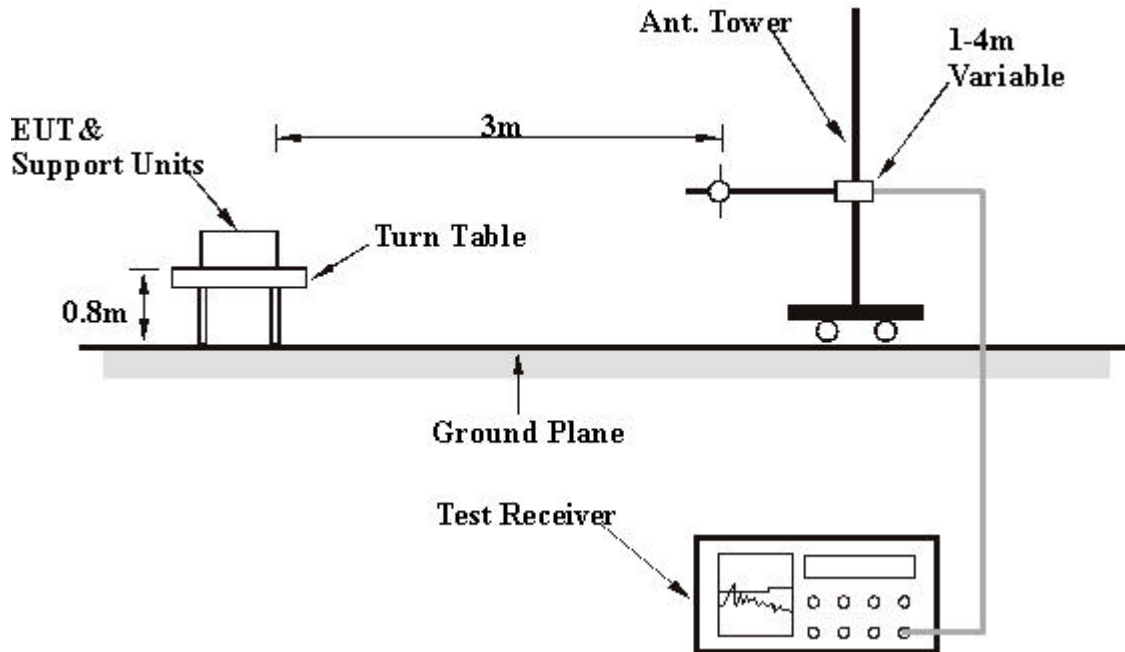

For the actual test configuration, please refer to the related item – Photographs of the Test Configuration.

4.2.7 EUT OPERATING CONDITIONS

Same as 4.1.6



4.2.8 TEST RESULTS

EUT	802.11a mini-PCI Module	MODEL	WMIA-105A
INPUT POWER (SYSTEM)	120Vac, 60 Hz	FREQUENCY RANGE	Below 1000MHz
ENVIRONMENTAL CONDITIONS	25deg. C, 55%RH, 991hPa	DETECTOR FUNCTION	Quasi-Peak
TESTED BY: Match Tsui			

ANTENNA POLARITY & TEST DISTANCE: HORIZONTAL AT 3 M								
No.	Freq. (MHz)	Emission Level (dBuV/m)	Limit (dBuV/m)	Margin (dB)	Antenna Height (m)	Table Angle (Degree)	Raw Value (dBuV)	Correction Factor (dB/m)
1	98.04	34.17 QP	43.50	-9.33	2.00 H	22	23.34	10.83
2	114.14	40.41 QP	43.50	-3.09	1.49 H	238	27.98	12.43
3	164.13	39.19 QP	43.50	-4.31	1.50 H	196	24.69	14.49
4	199.12	40.95 QP	43.50	-2.55	1.50 H	241	29.49	11.46
5	232.16	32.05 QP	46.00	-13.95	1.25 H	259	19.46	12.59
6	265.21	37.66 QP	46.00	-8.34	1.25 H	337	24.08	13.58
7	300.20	38.48 QP	46.00	-7.52	1.00 H	337	23.97	14.50
8	333.25	42.61 QP	46.00	-3.39	1.00 H	346	27.34	15.26
9	395.45	35.21 QP	46.00	-10.79	1.00 H	313	18.56	16.65
10	465.43	39.22 QP	46.00	-6.78	1.75 H	247	20.95	18.27
11	533.47	28.76 QP	46.00	-17.24	1.25 H	289	9.39	19.37
12	640.38	33.15 QP	46.00	-12.85	1.25 H	148	11.60	21.55
13	665.65	35.66 QP	46.00	-10.34	1.25 H	49	13.79	21.87
14	799.78	33.39 QP	46.00	-12.61	2.00 H	181	9.57	23.82
15	906.69	30.60 QP	46.00	-15.40	2.00 H	187	5.42	25.18

- REMARKS:**
1. Emission level(dBuV/m)=Raw Value(dBuV) + Correction Factor(dB/m)
 2. Correction Factor(dB/m) = Antenna Factor (dB/m) + Cable Factor (dB)
 3. The other emission levels were very low against the limit.
 4. Margin value = Emission level – Limit value.



EUT	802.11a mini-PCI Module	MODEL	WMIA-105A
INPUT POWER (SYSTEM)	120Vac, 60 Hz	FREQUENCY RANGE	Below 1000MHz
ENVIRONMENTAL CONDITIONS	25deg. C, 55%RH, 991hPa	DETECTOR FUNCTION	Quasi-Peak
TESTED BY: Match Tsui			

ANTENNA POLARITY & TEST DISTANCE: VERTICAL AT 3 M								
No.	Freq. (MHz)	Emission Level (dBuV/m)	Limit (dBuV/m)	Margin (dB)	Antenna Height (m)	Table Angle (Degree)	Raw Value (dBuV)	Correction Factor (dB/m)
1	64.99	29.15 QP	40.00	-10.85	1.25 V	94	16.00	13.15
2	99.98	29.87 QP	43.50	-13.63	1.50 V	169	18.89	10.98
3	115.53	33.53 QP	43.50	-9.97	1.00 V	262	20.96	12.57
4	168.02	33.73 QP	43.50	-9.77	1.50 V	175	19.61	14.12
5	201.06	35.18 QP	43.50	-8.32	1.75 V	142	23.77	11.41
6	265.21	33.49 QP	46.00	-12.51	1.75 V	178	19.92	13.58
7	333.25	33.55 QP	46.00	-12.45	1.25 V	304	18.29	15.26
8	379.90	34.03 QP	46.00	-11.97	1.00 V	334	17.72	16.31
9	449.88	31.60 QP	46.00	-14.40	1.00 V	313	13.53	18.07
10	465.43	37.81 QP	46.00	-8.19	1.00 V	310	19.54	18.27
11	531.52	30.97 QP	46.00	-15.03	1.00 V	337	11.63	19.34
12	597.62	28.68 QP	46.00	-17.32	1.00 V	250	7.73	20.95
13	665.65	36.12 QP	46.00	-9.88	1.50 V	223	14.25	21.87
14	799.78	29.89 QP	46.00	-16.11	1.75 V	202	6.07	23.82
15	935.85	31.66 QP	46.00	-14.34	1.25 V	259	6.17	25.49

- REMARKS:**
1. Emission level(dBuV/m)=Raw Value(dBuV) + Correction Factor(dB/m)
 2. Correction Factor(dB/m) = Antenna Factor (dB/m) + Cable Factor (dB)
 3. The other emission levels were very low against the limit.
 4. Margin value = Emission level – Limit value.



EUT	802.11a mini-PCI Module	MODEL	WMIA-105A
MODE	Normal Mode	CHANNEL	1
FREQUENCY RANGE	1 ~ 40 GHz	DETECTOR FUNCTION	Peak(PK) Average (AV)
ENVIRONMENTAL CONDITIONS	25deg. C, 60%RH, 991hPa	INPUT POWER (SYSTEM)	120Vac, 60Hz
TESTED BY	Match Tsui		

ANTENNA POLARITY & TEST DISTANCE: HORIZONTAL AT 3 M

No.	Freq. (MHz)	Emission Level (dBuV/m)	Limit (dBuV/m)	Margin (dB)	Antenna Height (m)	Table Angle (Degree)	Raw Value (dBuV)	Correction Factor (dB/m)
1	3453.00	61.95 PK	68.30	-6.35	1.07 H	109	26.37	35.58
2	#5150.00	48.14 PK	74.00	-25.86	1.06 H	119	9.04	39.10
2	#5150.00	38.09 AV	54.00	-15.91	1.06 H	119	-1.01	39.10
3	*5180.00	107.47 PK			1.06 H	119	68.30	39.17
3	*5180.00	97.42 AV			1.06 H	119	58.25	39.17
4	10360.00	61.85 PK	68.30	-6.45	1.45 H	146	16.56	45.29

ANTENNA POLARITY & TEST DISTANCE: VERTICAL AT 3 M

No.	Freq. (MHz)	Emission Level (dBuV/m)	Limit (dBuV/m)	Margin (dB)	Antenna Height (m)	Table Angle (Degree)	Raw Value (dBuV)	Correction Factor (dB/m)
1	3453.00	58.59 PK	68.30	-9.71	1.50 V	229	23.01	35.58
2	#5150.00	40.93 PK	74.00	-33.07	1.20 V	121	1.83	39.10
2	#5150.00	31.36 AV	54.00	-22.64	1.20 V	121	-7.74	39.10
3	*5180.00	100.26 PK			1.20 V	121	61.09	39.17
3	*5180.00	90.69 AV			1.20 V	121	51.52	39.17
4	10360.00	64.90 PK	68.30	-3.40	1.51 V	360	19.61	45.29

NOTE:

1. Emission level = Raw value + Correction Factor
2. Correction Factor = Ant. Factor + Cable loss
3. Margin value = Emission level - Limit value
4. The other emission levels were very low against the limit.
5. "*" : Fundamental frequency
6. "#" The radiated frequency falling in the restricted band.



EUT	802.11a mini-PCI Module	MODEL	WMIA-105A
MODE	Normal Mode	CHANNEL	4
FREQUENCY RANGE	1 ~ 40 GHz	DETECTOR FUNCTION	Peak(PK) Average (AV)
ENVIRONMENTAL CONDITIONS	25deg. C, 60%RH, 991hPa	INPUT POWER (SYSTEM)	120Vac, 60Hz
TESTED BY	Match Tsui		

ANTENNA POLARITY & TEST DISTANCE: HORIZONTAL AT 3 M

No.	Freq. (MHz)	Emission Level (dBuV/m)	Limit (dBuV/m)	Margin (dB)	Antenna Height (m)	Table Angle (Degree)	Raw Value (dBuV)	Correction Factor (dB/m)
1	3493.00	49.96 PK	68.30	-18.34	1.07 H	120	14.27	35.70
2	*5240.00	108.42 PK			1.04 H	123	69.24	39.18
2	*5240.00	97.69 AV			1.04 H	123	58.51	39.18
3	10480.00	66.99 PK	68.30	-1.31	1.48 H	132	20.90	46.08

ANTENNA POLARITY & TEST DISTANCE: VERTICAL AT 3 M

No.	Freq. (MHz)	Emission Level (dBuV/m)	Limit (dBuV/m)	Margin (dB)	Antenna Height (m)	Table Angle (Degree)	Raw Value (dBuV)	Correction Factor (dB/m)
1	3493.00	49.15 PK	68.30	-19.15	1.31 V	256	13.46	35.70
2	*5240.00	101.77 PK			1.17 V	118	62.59	39.18
2	*5240.00	91.66 AV			1.17 V	118	52.48	39.18
3	10480.00	63.24 PK	68.30	-5.06	1.30 V	68	17.15	46.08

NOTE:

1. Emission level = Raw value + Correction Factor
2. Correction Factor = Ant. Factor + Cable loss
3. Margin value = Emission level - Limit value
4. The other emission levels were very low against the limit.
5. "*" : Fundamental frequency
6. "#" The radiated frequency falling in the restricted band.



EUT	802.11a mini-PCI Module	MODEL	WMIA-105A
MODE	Normal Mode	CHANNEL	5
FREQUENCY RANGE	1 ~ 40 GHz	DETECTOR FUNCTION	Peak(PK) Average (AV)
ENVIRONMENTAL CONDITIONS	25deg. C, 60%RH, 991hPa	INPUT POWER (SYSTEM)	120Vac, 60Hz
TESTED BY	Match Tsui		

ANTENNA POLARITY & TEST DISTANCE: HORIZONTAL AT 3 M

No.	Freq. (MHz)	Emission Level (dBuV/m)	Limit (dBuV/m)	Margin (dB)	Antenna Height (m)	Table Angle (Degree)	Raw Value (dBuV)	Correction Factor (dB/m)
1	3506.00	49.86 PK	68.30	-18.44	1.26 H	122	14.12	35.73
2	*5260.00	107.62 PK			1.04 H	132	68.46	39.16
2	*5260.00	96.86 AV			1.04 H	132	57.70	39.16
3	10520.00	65.28 PK	68.30	-3.02	1.46 H	133	19.13	46.16

ANTENNA POLARITY & TEST DISTANCE: VERTICAL AT 3 M

No.	Freq. (MHz)	Emission Level (dBuV/m)	Limit (dBuV/m)	Margin (dB)	Antenna Height (m)	Table Angle (Degree)	Raw Value (dBuV)	Correction Factor (dB/m)
1	3506.00	48.27 PK	68.30	-20.03	1.26 V	252	12.53	35.73
2	*5260.00	102.51 PK			1.03 V	118	63.35	39.16
2	*5260.00	92.66 AV			1.03 V	118	53.50	39.16
3	10520.00	63.30 PK	68.30	-5.00	1.33 V	61	17.15	46.16

NOTE:

1. Emission level = Raw value + Correction Factor
2. Correction Factor = Ant. Factor + Cable loss
3. Margin value = Emission level - Limit value
4. The other emission levels were very low against the limit.
5. "*" : Fundamental frequency
6. "#" The radiated frequency falling in the restricted band.



EUT	802.11a mini-PCI Module	MODEL	WMIA-105A
MODE	Normal Mode	CHANNEL	8
FREQUENCY RANGE	1 ~ 40 GHz	DETECTOR FUNCTION	Peak(PK) Average (AV)
ENVIRONMENTAL CONDITIONS	25deg. C, 55%RH, 991hPa	INPUT POWER (SYSTEM)	120Vac, 60Hz
TESTED BY	Match Tsui		

ANTENNA POLARITY & TEST DISTANCE: HORIZONTAL AT 3 M								
No.	Freq. (MHz)	Emission Level (dBuV/m)	Limit (dBuV/m)	Margin (dB)	Antenna Height (m)	Table Angle (Degree)	Raw Value (dBuV)	Correction Factor (dB/m)
1	3546.00	47.99 PK	68.30	-20.31	1.29 H	186	12.14	35.85
2	*5320.00	107.40 PK			1.05 H	88	68.25	39.15
2	*5320.00	97.06 AV			1.05 H	88	57.91	39.15
3	#5350.00	48.83 PK	74.00	-25.17	1.05 H	88	9.63	39.20
3	#5350.00	38.49 AV	54.00	-15.51	1.05 H	88	-0.71	39.20
4	7093.00	53.42 PK	68.30	-14.88	1.31 H	22	10.90	42.52
5	#10640.00	59.60 PK	74.00	-14.40	1.27 H	117	13.37	46.23
5	#10640.00	47.32 AV	54.00	-6.68	1.27 H	117	1.09	46.23
6	#15960.00	58.65 PK	74.00	-15.35	1.29 H	135	13.69	44.96
6	#15960.00	46.07 AV	54.00	-7.93	1.29 H	135	1.11	44.96

ANTENNA POLARITY & TEST DISTANCE: VERTICAL AT 3 M								
No.	Freq. (MHz)	Emission Level (dBuV/m)	Limit (dBuV/m)	Margin (dB)	Antenna Height (m)	Table Angle (Degree)	Raw Value (dBuV)	Correction Factor (dB/m)
1	3546.00	48.71 PK	68.30	-19.59	1.34 V	238	12.86	35.85
2	*5320.00	101.82 PK			1.15 V	116	62.67	39.15
2	*5320.00	91.94 AV			1.15 V	116	52.79	39.15
3	#5350.00	43.25 PK	74.00	-30.75	1.15 V	116	4.05	39.20
3	#5350.00	33.37 AV	54.00	-20.63	1.15 V	116	-5.83	39.20
4	#10640.00	61.39 PK	74.00	-12.61	1.31 V	16	15.16	46.23
4	#10640.00	49.53 AV	54.00	-4.47	1.31 V	16	3.30	46.23
5	#15960.00	63.90 PK	74.00	-10.10	1.22 V	131	18.94	44.96
5	#15960.00	51.01 AV	54.00	-2.99	1.22 V	131	6.05	44.96

NOTE:

1. Emission level = Raw value + Correction Factor
2. Correction Factor = Ant. Factor + Cable loss
3. Margin value = Emission level - Limit value
4. The other emission levels were very low against the limit.
5. "*" : Fundamental frequency
6. "#" The radiated frequency falling in the restricted band.



EUT	802.11a mini-PCI Module	MODEL	WMIA-105A
MODE	Turbo Mode	CHANNEL	1
FREQUENCY RANGE	1 ~ 40 GHz	DETECTOR FUNCTION	Peak(PK) Average (AV)
ENVIRONMENTAL CONDITIONS	25deg. C, 60%RH, 991hPa	INPUT POWER (SYSTEM)	120Vac, 60Hz
TESTED BY	Match Tsui		

ANTENNA POLARITY & TEST DISTANCE: HORIZONTAL AT 3 M

No.	Freq. (MHz)	Emission Level (dBuV/m)	Limit (dBuV/m)	Margin (dB)	Antenna Height (m)	Table Angle (Degree)	Raw Value (dBuV)	Correction Factor (dB/m)
1	3473.00	53.46 PK	68.30	-14.84	1.26 H	119	17.82	35.64
2	#5150.00	53.48 PK	74.00	-20.52	1.05 H	129	14.38	39.10
2	#5150.00	44.08 AV	54.00	-9.92	1.05 H	129	4.98	39.10
3	*5210.00	103.35 PK			1.05 H	129	64.14	39.21
3	*5210.00	93.95 AV			1.05 H	129	54.74	39.21
4	10420.00	61.33 PK	68.30	-6.97	1.51 H	141	15.56	45.77

ANTENNA POLARITY & TEST DISTANCE: VERTICAL AT 3 M

No.	Freq. (MHz)	Emission Level (dBuV/m)	Limit (dBuV/m)	Margin (dB)	Antenna Height (m)	Table Angle (Degree)	Raw Value (dBuV)	Correction Factor (dB/m)
1	3473.00	47.36 PK	68.30	-20.94	1.46 V	57	11.72	35.64
2	#5150.00	47.87 PK	74.00	-26.13	1.46 V	121	8.77	39.10
2	#5150.00	38.39 AV	54.00	-15.61	1.46 V	121	-0.71	39.10
3	*5210.00	97.74 PK			1.46 V	121	58.53	39.21
3	*5210.00	88.26 AV			1.46 V	121	49.05	39.21
4	10420.00	61.55 PK	68.30	-6.75	1.49 V	198	15.78	45.77

NOTE:

1. Emission level = Raw value+ Correction Factor
2. Correction Factor = Ant. Factor + Cable loss
3. Margin value = Emission level - Limit value
4. The other emission levels were very low against the limit.
5. "*" : Fundamental frequency
6. "#" The radiated frequency falling in the restricted band.



EUT	802.11a mini-PCI Module	MODEL	WMIA-105A
MODE	Turbo Mode	CHANNEL	2
FREQUENCY RANGE	1 ~ 40 GHz	DETECTOR FUNCTION	Peak(PK) Average (AV)
ENVIRONMENTAL CONDITIONS	25deg. C, 60%RH, 991hPa	INPUT POWER (SYSTEM)	120Vac, 60Hz
TESTED BY	Match Tsui		

ANTENNA POLARITY & TEST DISTANCE: HORIZONTAL AT 3 M

No.	Freq. (MHz)	Emission Level (dBuV/m)	Limit (dBuV/m)	Margin (dB)	Antenna Height (m)	Table Angle (Degree)	Raw Value (dBuV)	Correction Factor (dB/m)
1	3500.00	49.19 PK	68.30	-19.11	1.28 H	200	13.47	35.72
2	*5250.00	104.98 PK			1.05 H	117	65.81	39.17
2	*5250.00	95.37 AV			1.05 H	117	56.20	39.17
3	10500.00	65.43 PK	68.30	-2.87	1.48 H	56	19.24	46.19
4	#15750.00	61.48 PK	74.00	-12.52	1.57 H	40	13.97	47.51
4	#15750.00	48.47 AV	54.00	-5.53	1.57 H	40	0.96	47.51

ANTENNA POLARITY & TEST DISTANCE: VERTICAL AT 3 M

No.	Freq. (MHz)	Emission Level (dBuV/m)	Limit (dBuV/m)	Margin (dB)	Antenna Height (m)	Table Angle (Degree)	Raw Value (dBuV)	Correction Factor (dB/m)
1	3500.00	46.77 PK	68.30	-21.53	1.24 V	48	11.05	35.72
2	*5250.00	98.40 PK			1.09 V	297	59.23	39.17
2	*5250.00	88.40 AV			1.09 V	297	49.23	39.17
3	10500.00	62.20 PK	68.30	-6.10	1.40 V	21	16.01	46.19
4	#15750.00	60.11 PK	74.00	-13.89	1.24 V	48	12.60	47.51
4	#15750.00	48.01 AV	54.00	-5.99	1.24 V	48	0.50	47.51

NOTE:

1. Emission level = Raw value + Correction Factor
2. Correction Factor = Ant. Factor + Cable loss
3. Margin value = Emission level - Limit value
4. The other emission levels were very low against the limit.
5. “#” The radiated frequency falling in the restricted band.



EUT	802.11a mini-PCI Module	MODEL	WMIA-105A
MODE	Turbo Mode	CHANNEL	3
FREQUENCY RANGE	1 ~ 40 GHz	DETECTOR FUNCTION	Peak(PK) Average (AV)
ENVIRONMENTAL CONDITIONS	25deg. C, 60%RH, 991hPa	INPUT POWER (SYSTEM)	120Vac, 60Hz
TESTED BY	Match Tsui		

ANTENNA POLARITY & TEST DISTANCE: HORIZONTAL AT 3 M

No.	Freq. (MHz)	Emission Level (dBuV/m)	Limit (dBuV/m)	Margin (dB)	Antenna Height (m)	Table Angle (Degree)	Raw Value (dBuV)	Correction Factor (dB/m)
1	3526.00	50.64 PK	68.30	-17.66	1.24 H	122	14.85	35.79
2	*5290.00	104.76 PK			1.14 H	12	65.63	39.13
2	*5290.00	95.13 AV			1.14 H	12	56.00	39.13
3	#5350.00	52.10 PK	74.00	-21.90	1.14 H	12	12.90	39.20
3	#5350.00	42.47 AV	54.00	-11.53	1.14 H	12	3.27	39.20
4	10580.00	61.00 PK	68.30	-7.30	1.43 H	121	14.93	46.07

ANTENNA POLARITY & TEST DISTANCE: VERTICAL AT 3 M

No.	Freq. (MHz)	Emission Level (dBuV/m)	Limit (dBuV/m)	Margin (dB)	Antenna Height (m)	Table Angle (Degree)	Raw Value (dBuV)	Correction Factor (dB/m)
1	3526.00	49.99 PK	68.30	-18.31	1.32 V	254	14.20	35.79
2	*5290.00	98.20 PK			1.17 V	124	59.07	39.13
2	*5290.00	89.07 AV			1.17 V	124	49.94	39.13
3	#5350.00	45.54 PK	74.00	-28.46	1.17 V	124	6.34	39.20
3	#5350.00	36.41 AV	54.00	-17.59	1.17 V	124	-2.79	39.20
4	10580.00	62.20 PK	68.30	-6.10	1.04 V	340	16.13	46.07

NOTE:

1. Emission level = Raw value + Correction Factor
2. Correction Factor = Ant. Factor + Cable loss
3. Margin value = Emission level - Limit value
4. The other emission levels were very low against the limit.
5. "*" : Fundamental frequency
6. "#" The radiated frequency falling in the restricted band.



4.3 PEAK TRANSMIT POWER MEASUREMENT

4.3.1 LIMITS OF PEAK TRANSMIT POWER MEASUREMENT

Frequency Band	Limit
5.15 – 5.25GHz	The lesser of 50mW (17dBm) or 4dBm + 10logB
5.25 – 5.35GHz	The lesser of 250mW (24dBm) or 11dBm + 10logB
5.725 – 5.825GHz	The lesser of 1W (30dBm) or 17dBm + 10logB

NOTE: Where B is the 26dB emission bandwidth in MHz.

4.3.2 TEST INSTRUMENTS

Description & Manufacturer	Model No.	Serial No.	Calibrated Until
R&S SPECTRUM ANALYZER	FSEK30	100049	Aug. 12, 2005

NOTE: The calibration interval of the above test instruments is 12 months and the calibrations are traceable to NML/ROC and NIST/USA.

4.3.3 TEST PROCEDURE

1. The transmitter output was connected to the spectrum analyzer.
2. Set span to encompass the entire emission bandwidth of the signal.
3. Set RBW to 1MHz, VBW to 300kHz.
4. Using the spectrum analyzer's channel power measurement function to measure the output power.

4.3.4 DEVIATION FROM TEST STANDARD

No deviation

4.3.5 TEST SETUP

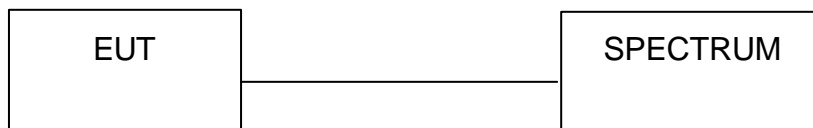

4.3.6 EUT OPERATING CONDITIONS

The software provided by client to enable the EUT under transmission condition continuously at specific channel frequencies individually.



4.3.7 TEST RESULTS

EUT	802.11a mini-PCI Module	MODEL	WMIA-105A
MODE	Normal	INPUT POWER (SYSTEM)	120Vac, 60 Hz
ENVIRONMENTAL CONDITIONS	24deg. C, 64%RH, 991hPa	TESTED BY	Leo Hung

CHANNEL	CHANNEL FREQUENCY (MHz)	PEAK POWER OUTPUT (mW)	PEAK POWER OUTPUT (dBm)	PEAK POWER LIMIT (dBm)	26dBc Occupied Bandwidth (MHz)	PASS/FAIL
1	5180	25.293	14.03	17.00	29.96	PASS
4	5240	25.527	14.07	17.00	28.98	PASS
5	5260	25.586	14.08	24.00	26.74	PASS
8	5320	25.586	14.08	24.00	26.81	PASS

NOTE: The 26dBc Occupied Bandwidth plot, please refer to the following pages.



Peak Power Output:
CH1

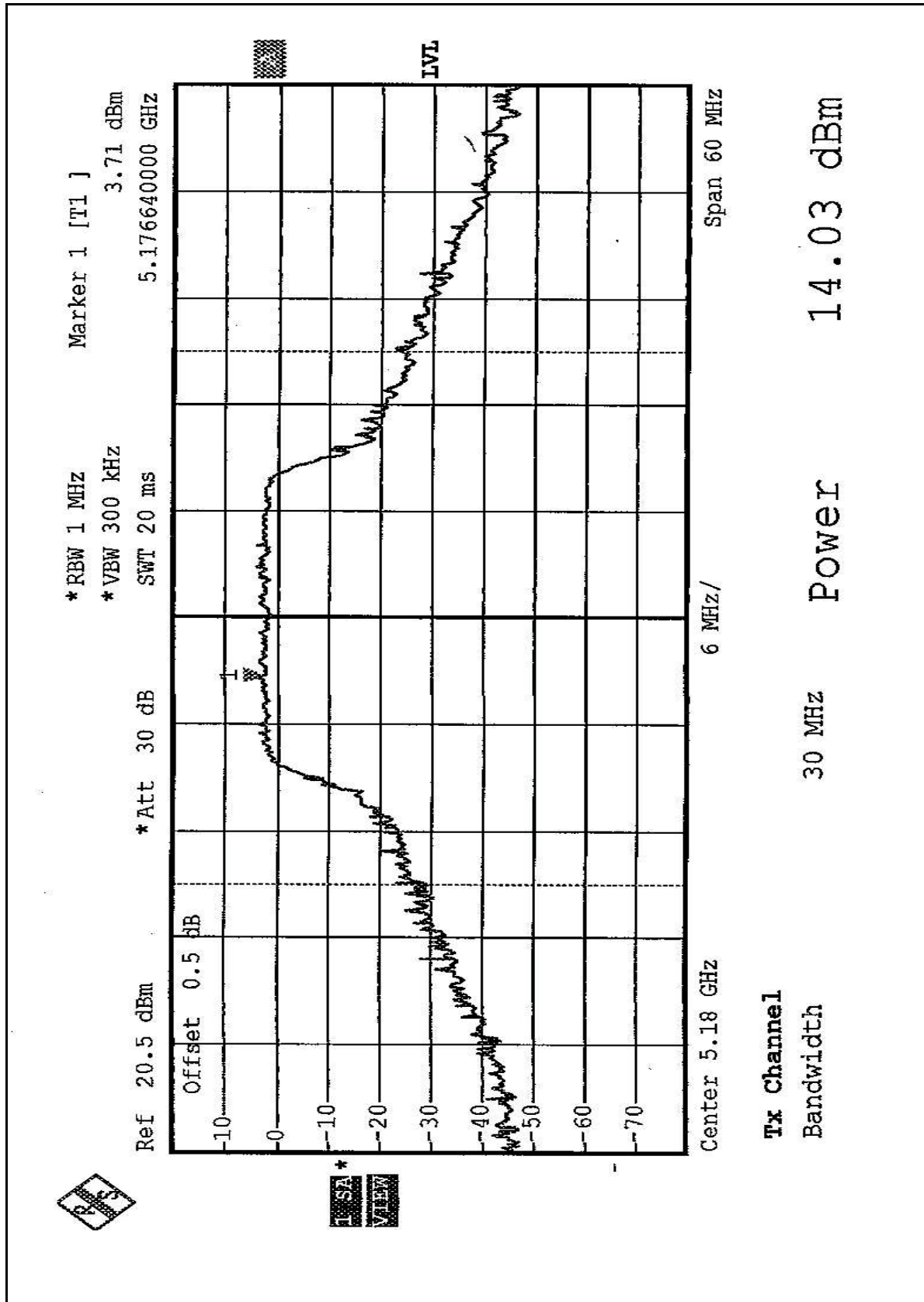



CH4

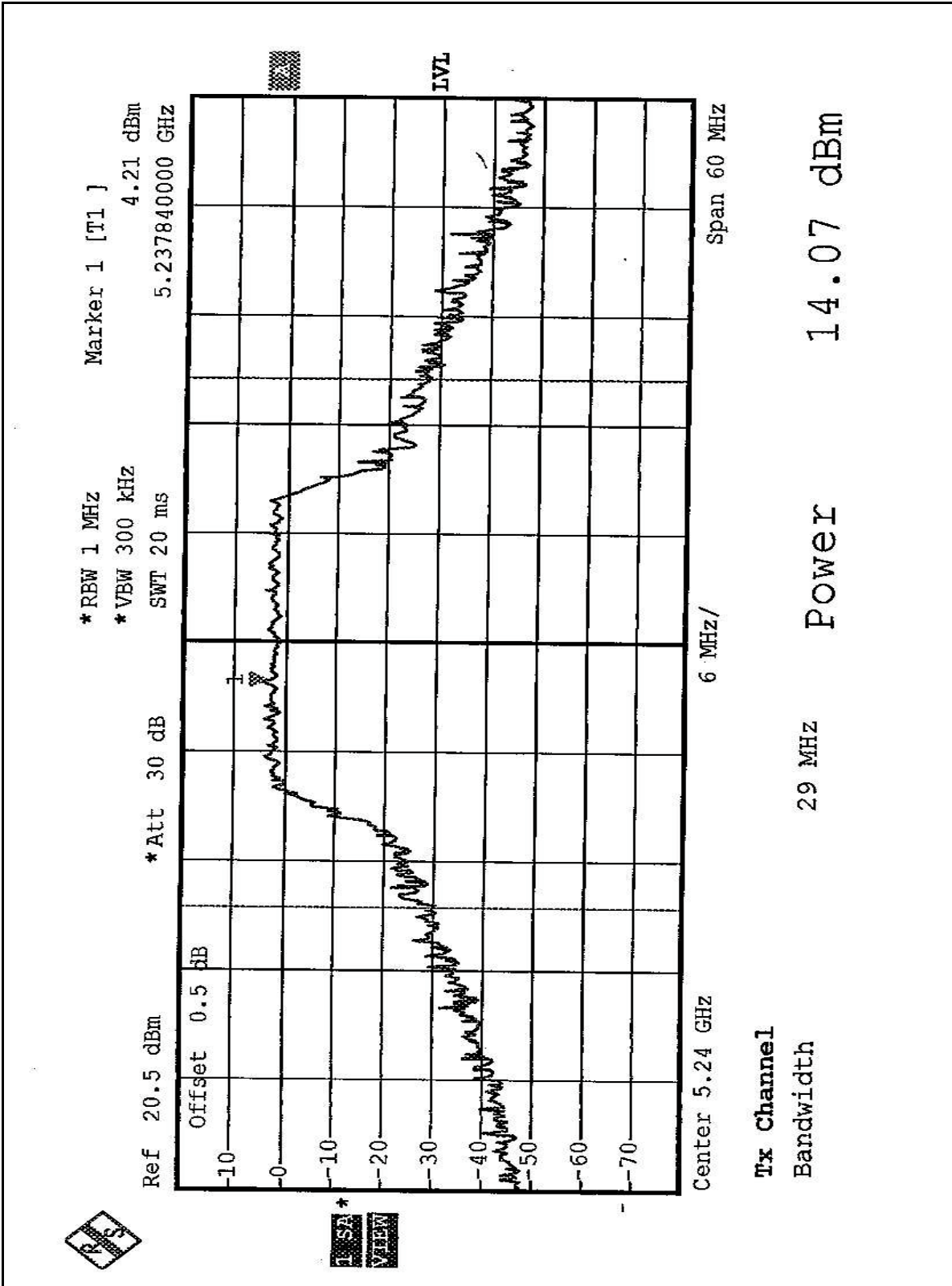



CH5

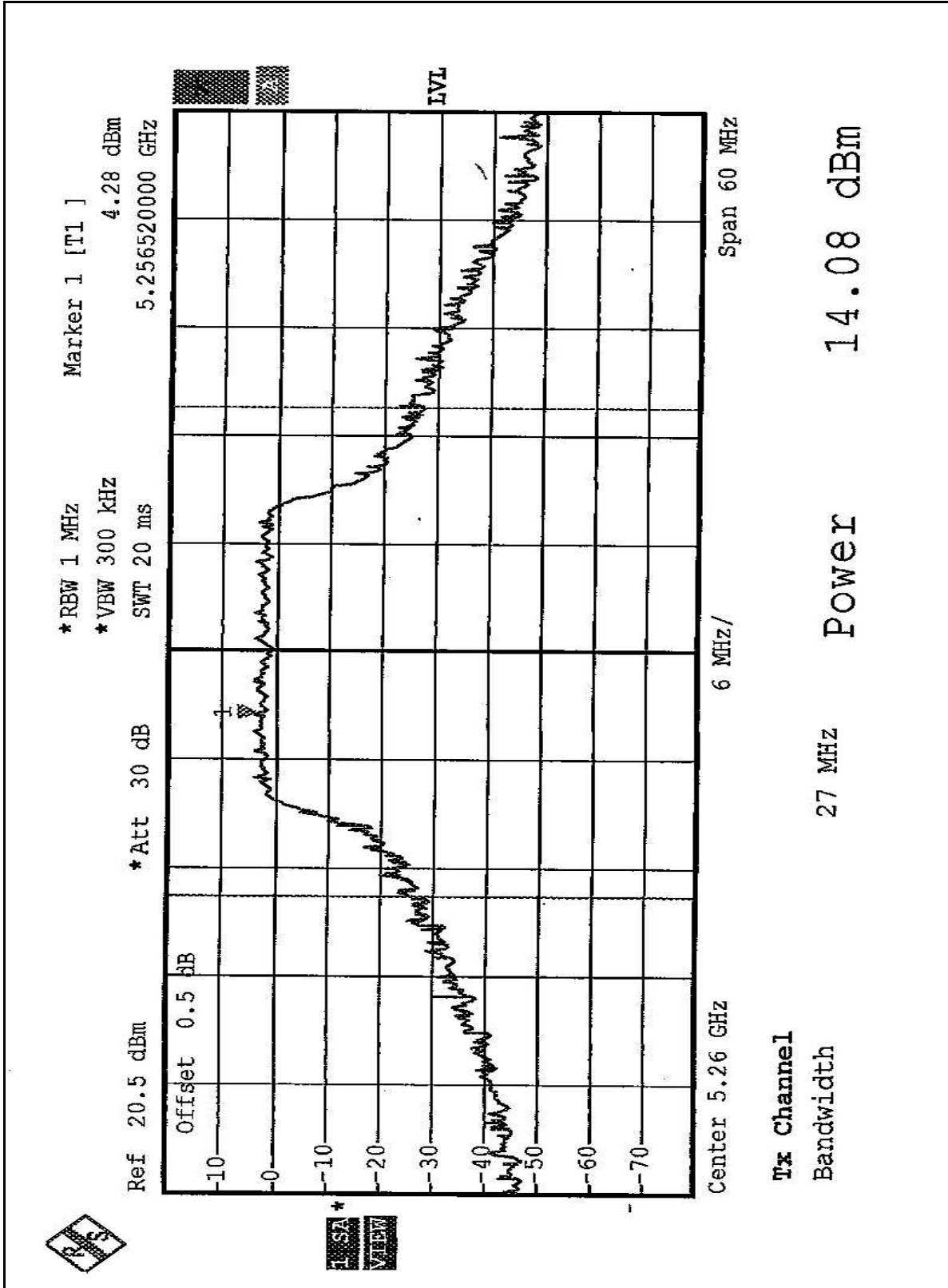



CH8

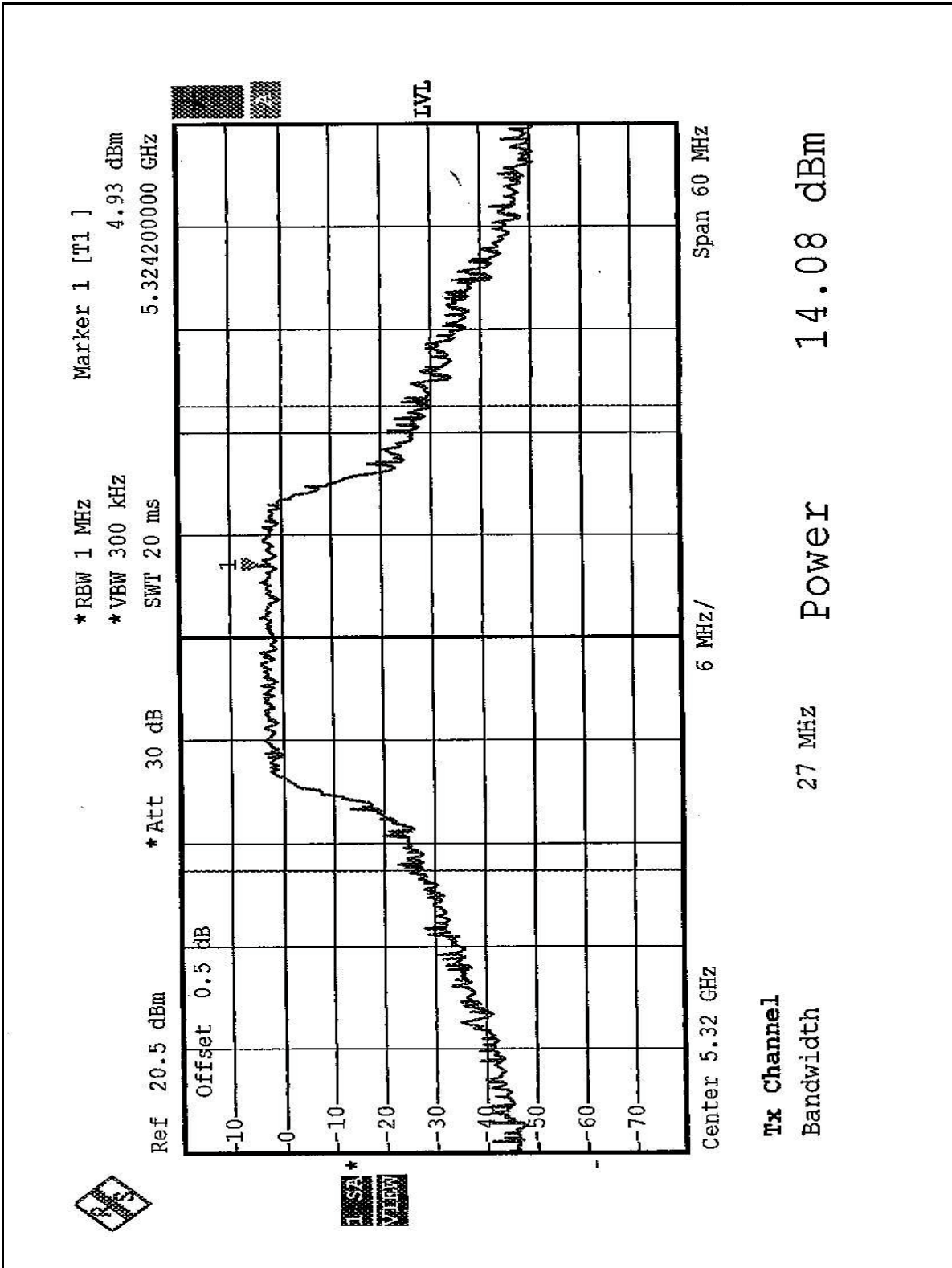



26dB Occupied Bandwidth:
CH1

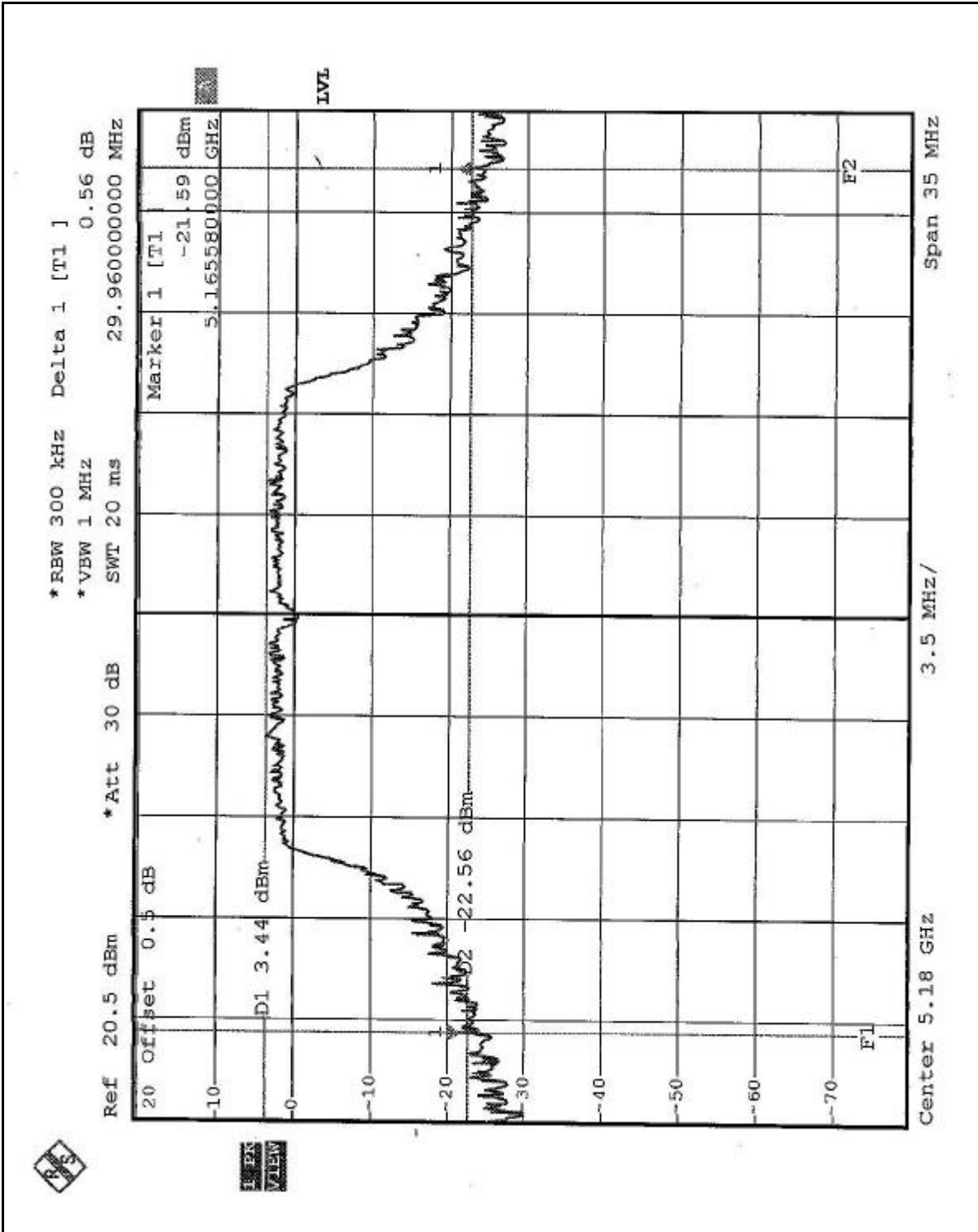



CH4

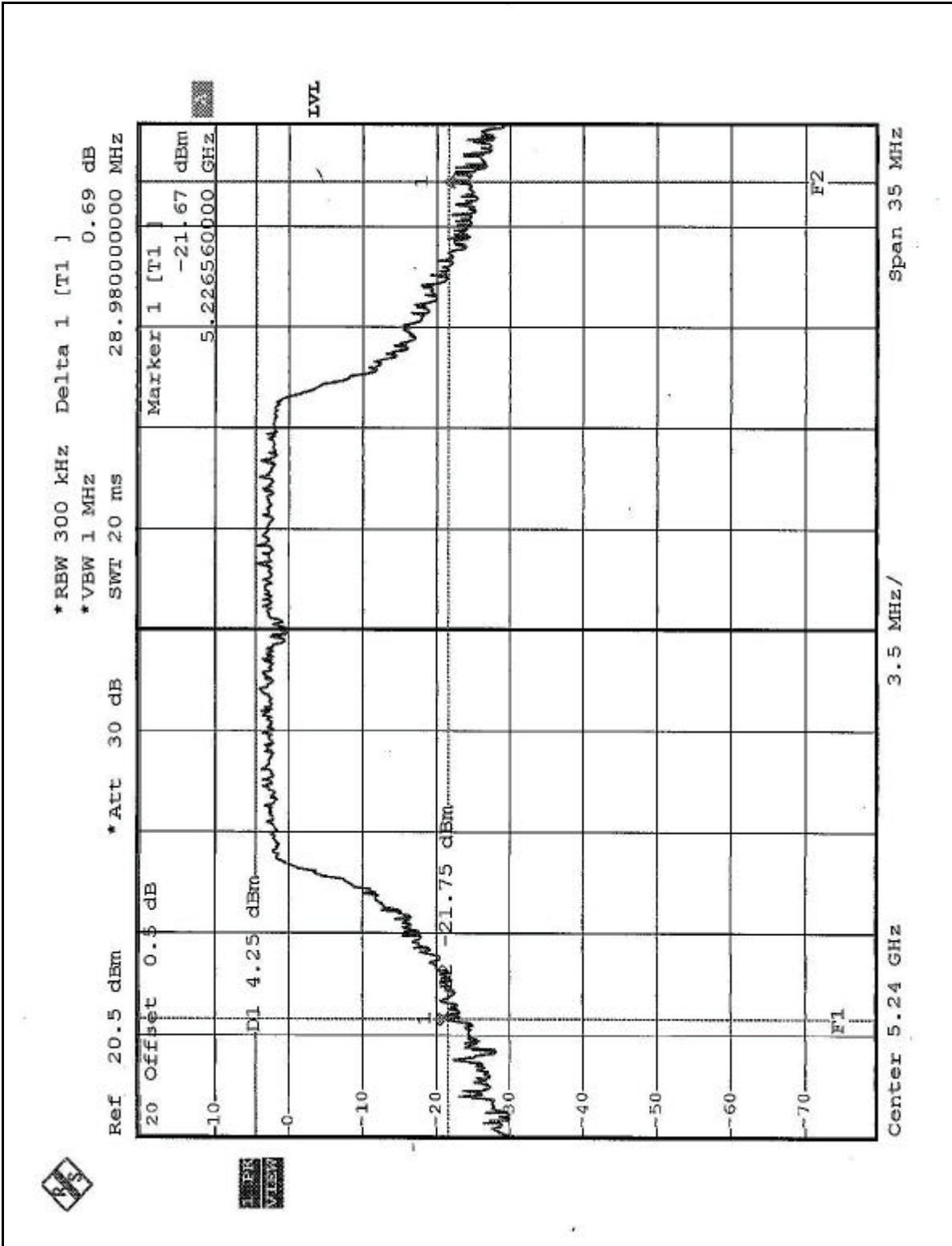



CH5

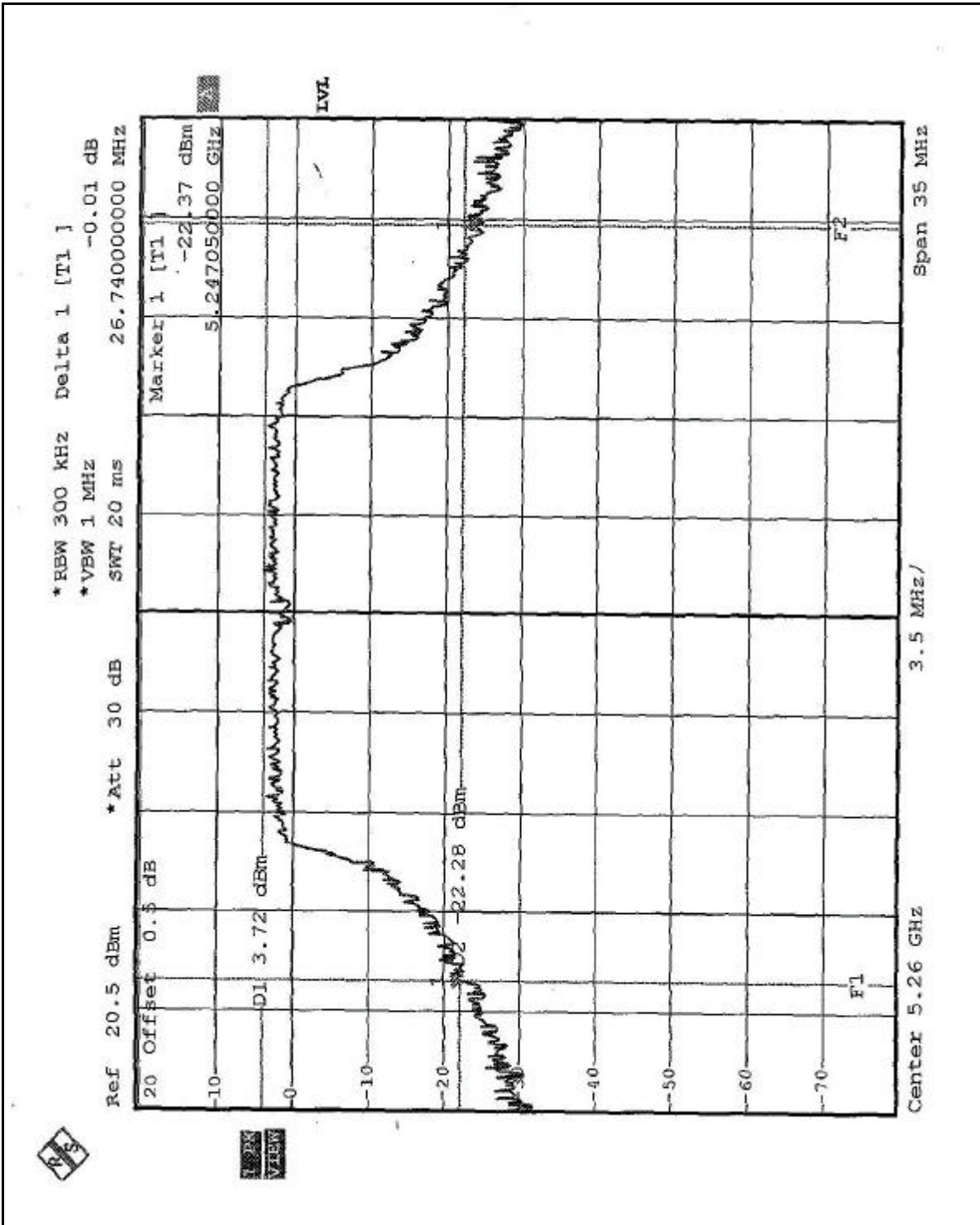



CH8

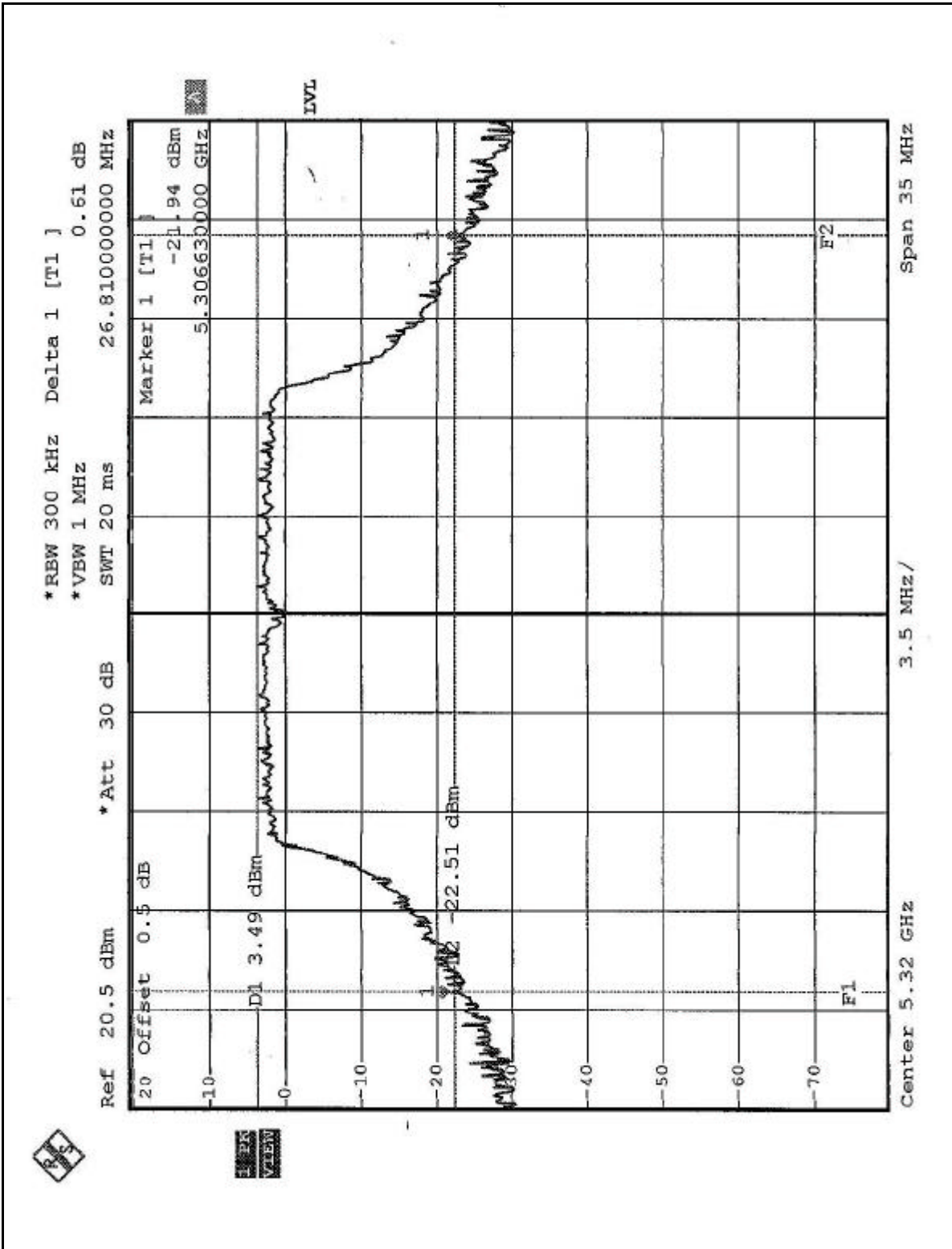



EUT	802.11a mini-PCI Module	MODEL	WMIA-105A
MODE	Turbo	INPUT POWER (SYSTEM)	120Vac, 60 Hz
ENVIRONMENTAL CONDITIONS	24deg. C, 64%RH, 991hPa	TESTED BY	Leo Hung

CHANNEL	CHANNEL FREQUENCY (MHz)	PEAK POWER OUTPUT (mW)	PEAK POWER OUTPUT (dBm)	PEAK POWER LIMIT (dBm)	26dBc Occupied Bandwidth (MHz)	PASS/FAIL
1	5210	25.527	14.07	17.00	50.04	PASS
2	5250	25.586	14.08	17.00	50.52	PASS
3	5290	25.645	14.09	24.00	48.00	PASS

NOTE: The 26dBc Occupied Bandwidth plot, please refer to the following pages.



Peak Power Output:
CH1

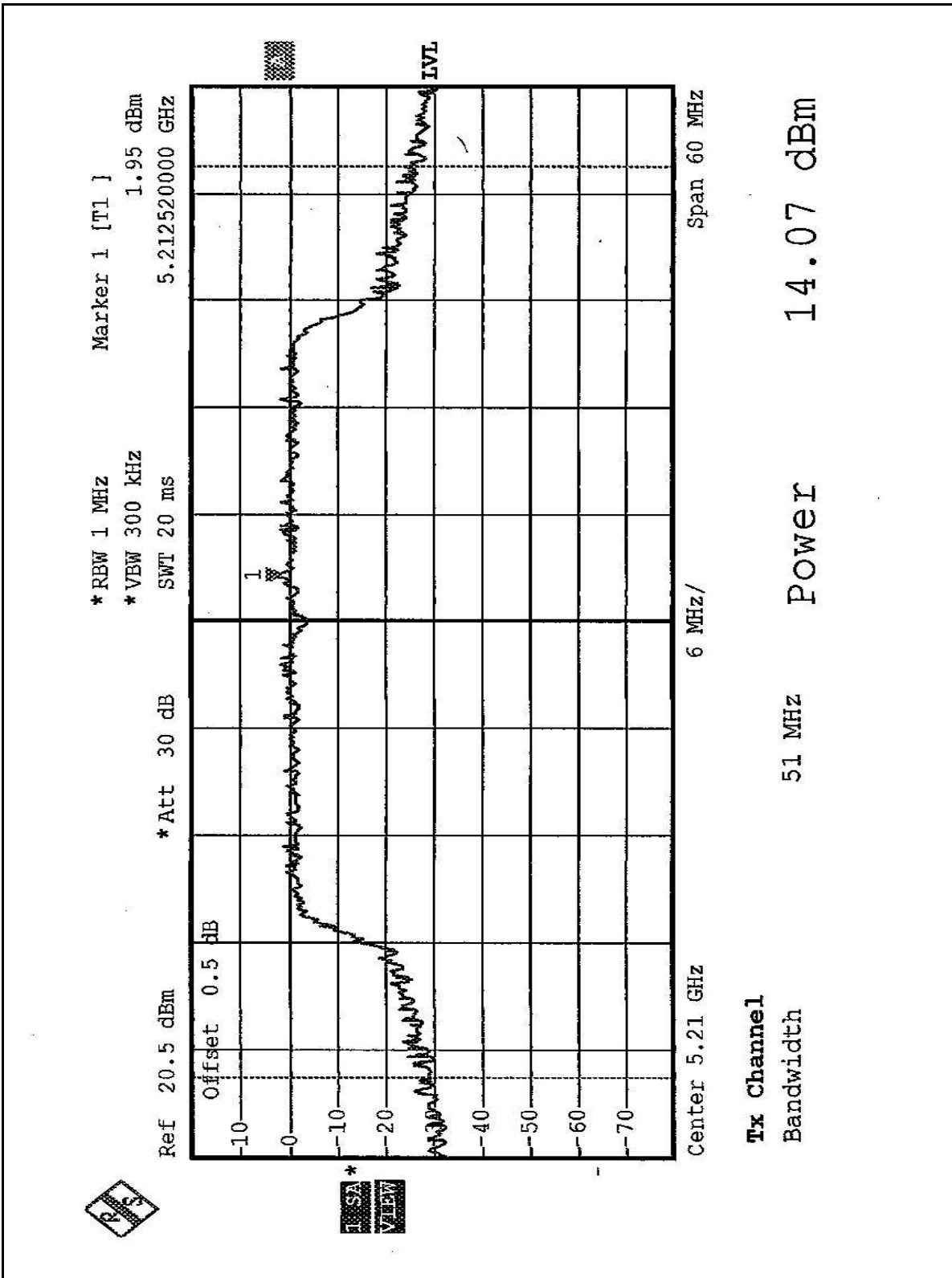



CH2

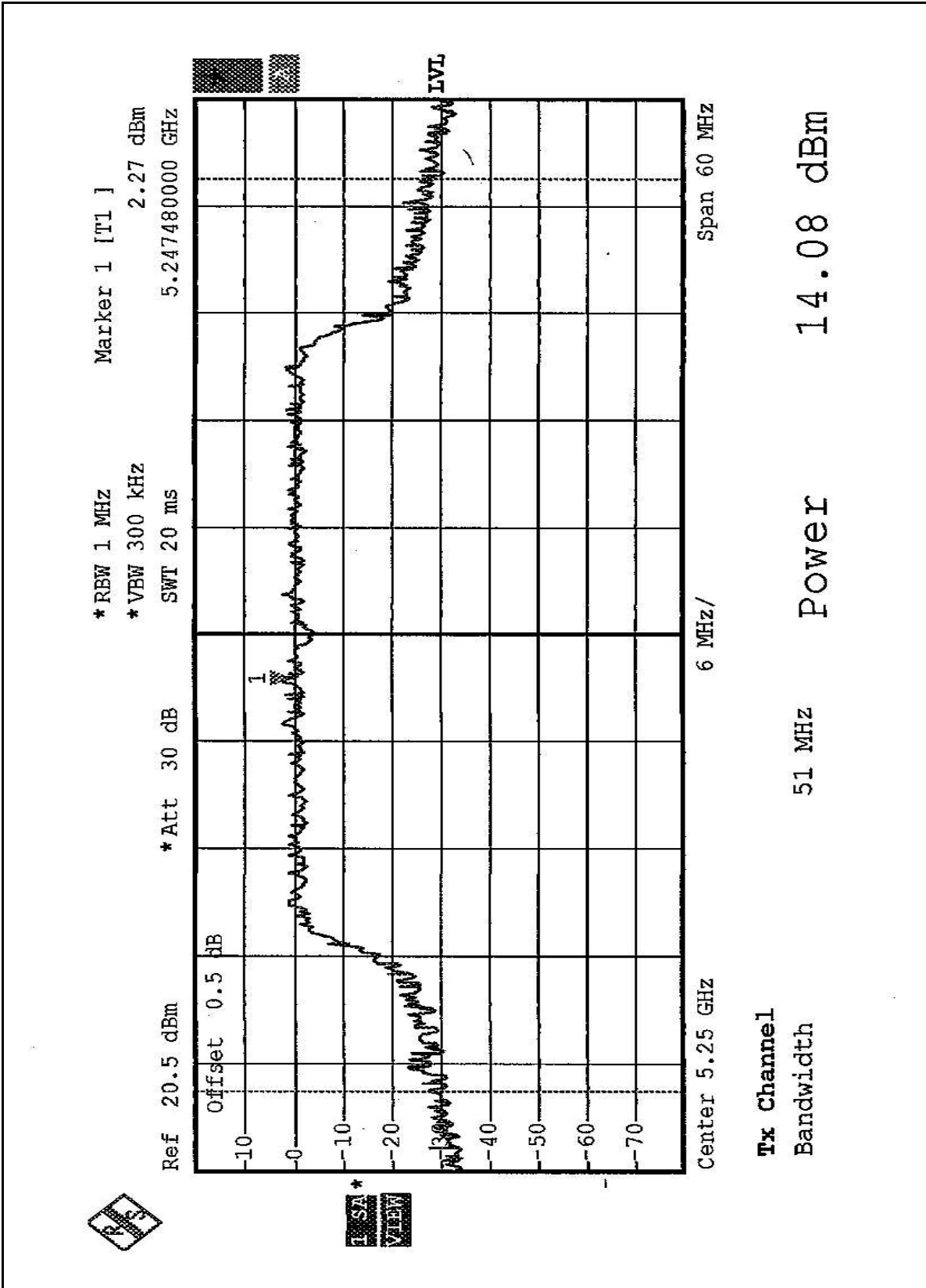



CH3

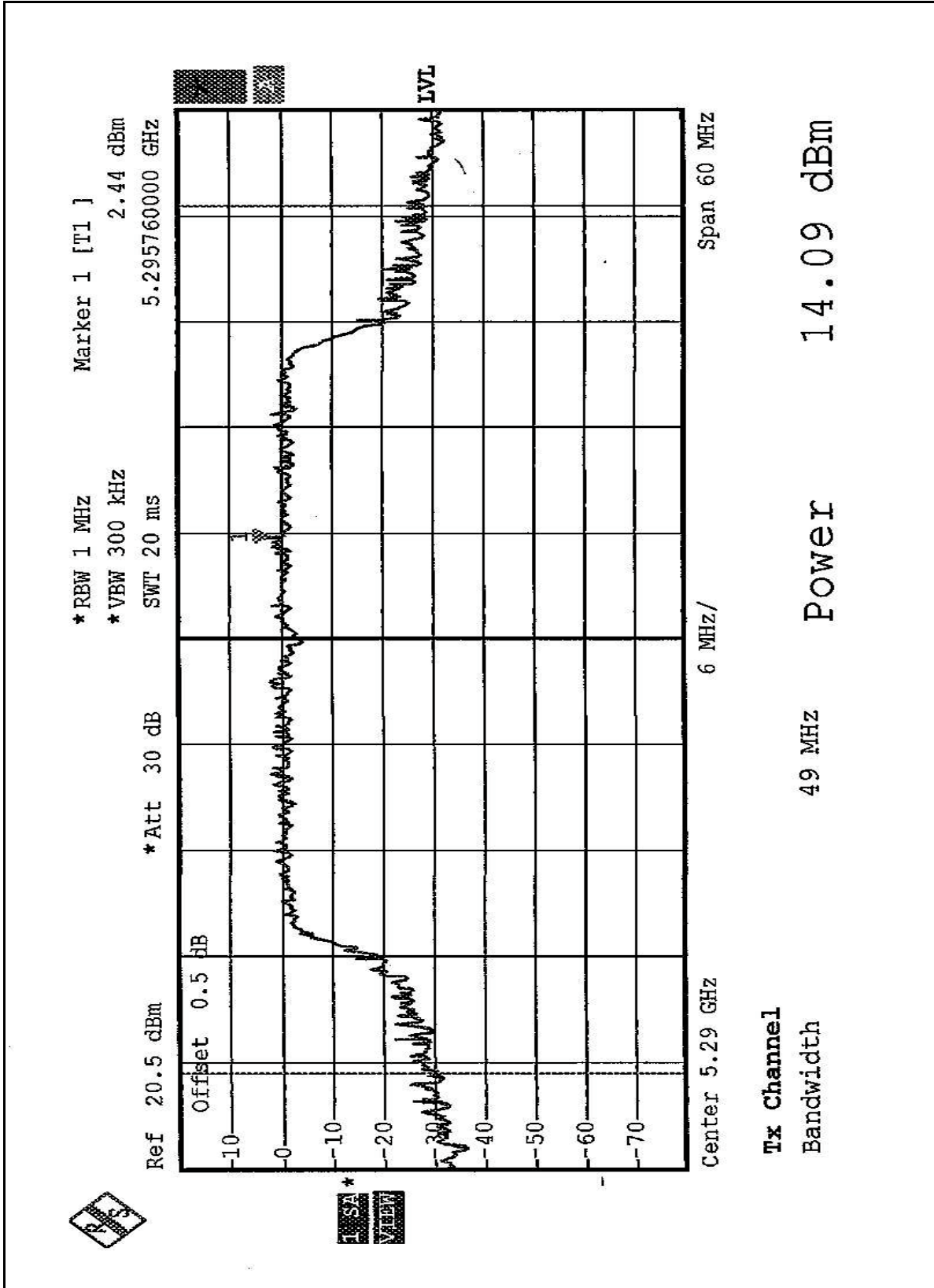



26dB Occupied Bandwidth:
CH1

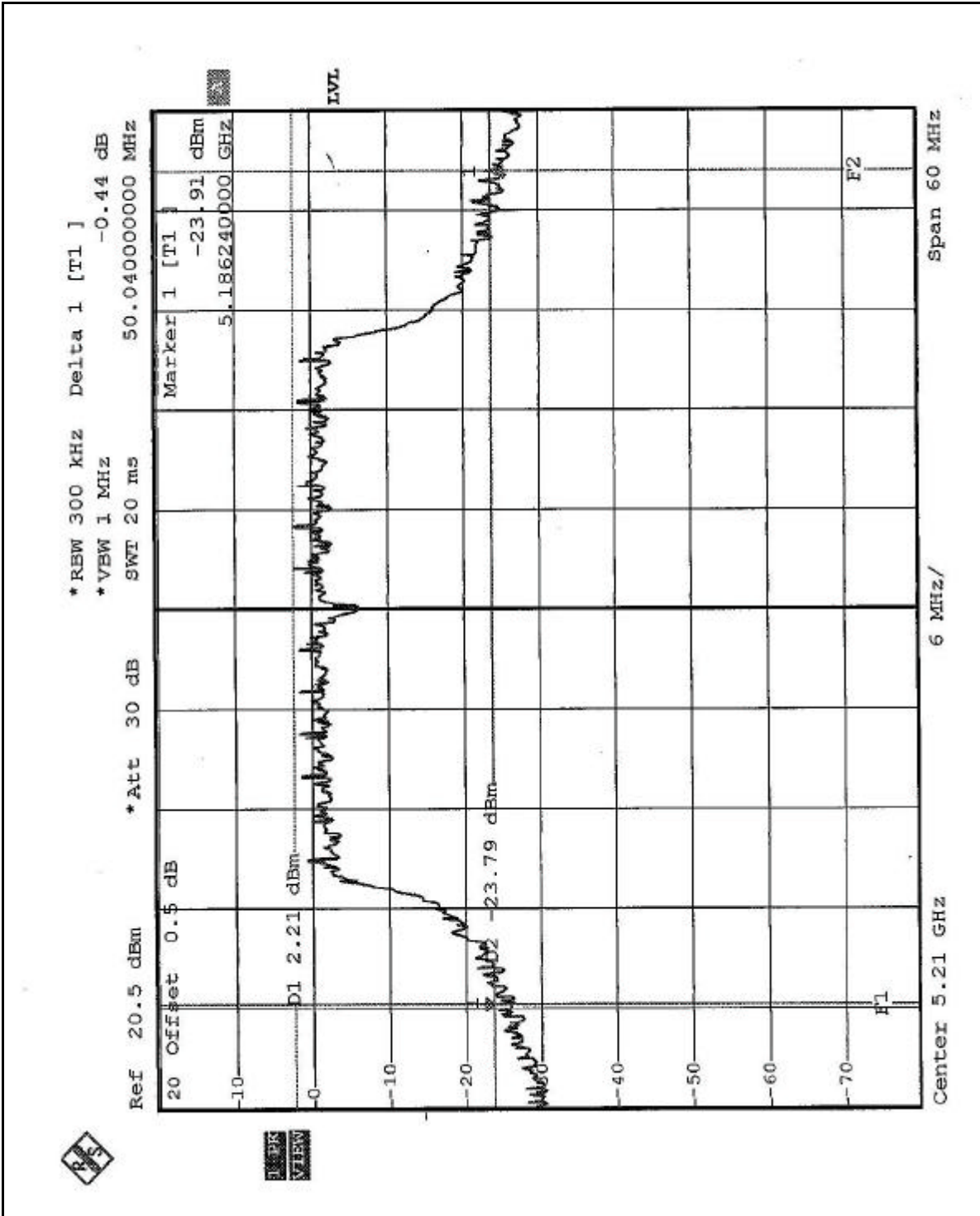



CH2

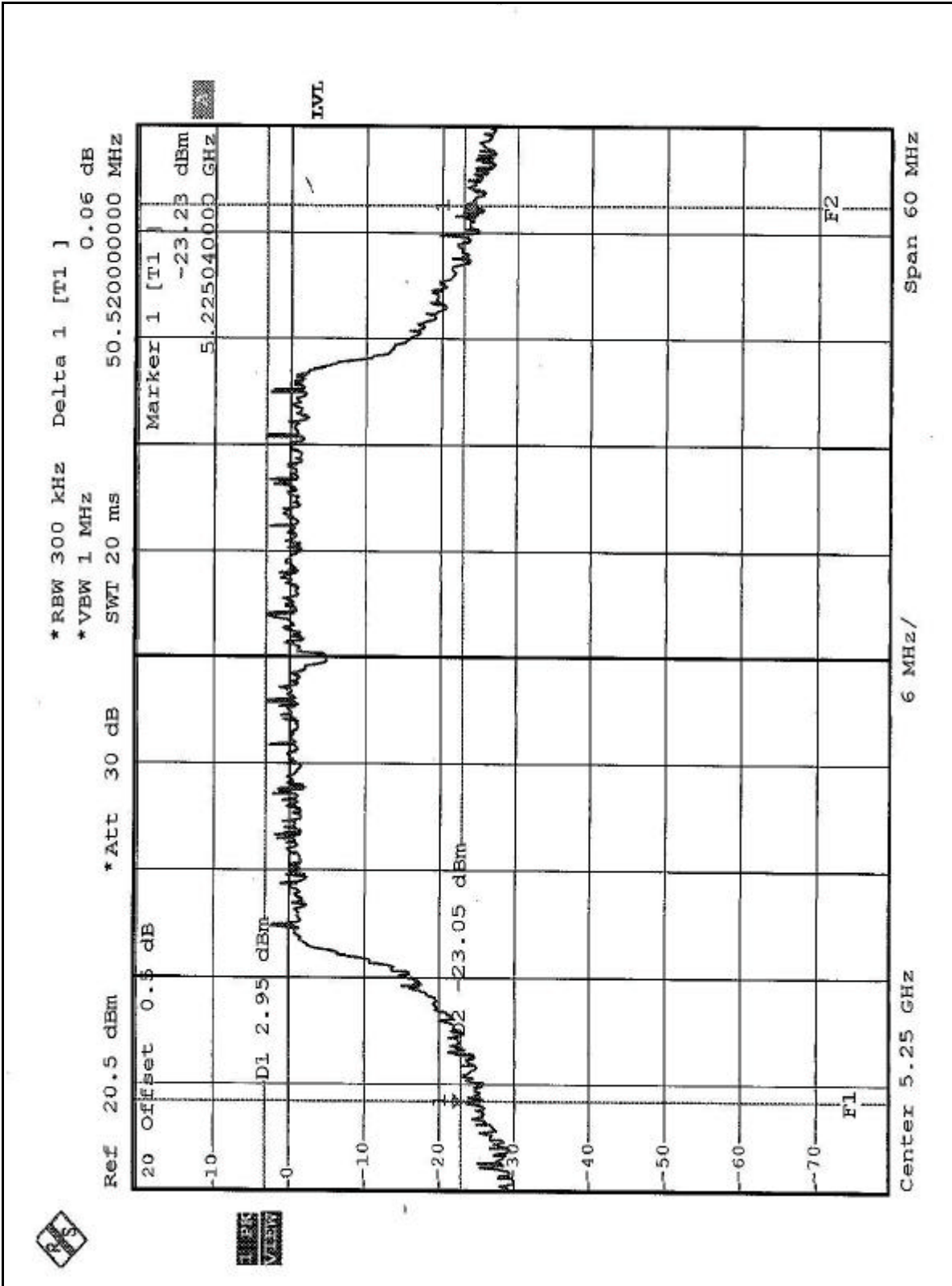



CH3

