

## 火焰灯音箱

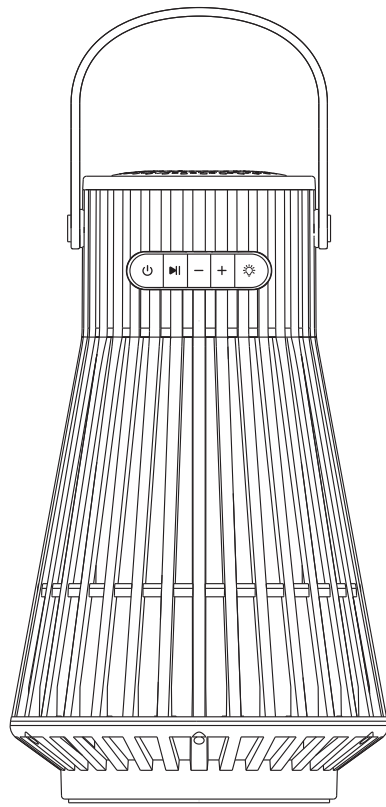

使用前请仔细阅读

### 产品简介



- 按键式操作, 方便快捷
- 火焰灯功能
- 夜灯功能
- 无线音箱功能
- 支持任意两个音箱串联立体声输出, 左右声道分开形成对箱, 沉浸式体验
- 声音效果更加完美
- 使用单个音箱时, 左右声道合并输出
- 音箱开机时蓝色指示灯在闪烁, 连接成功后蓝色指示灯长亮
- 内置大容量可充电锂电池, 户外使用更方便
- IP65级防尘防水
- 音箱充电时指示灯显示红色, 充满电后指示灯熄灭

### 规格参数

版本	V5.0	失真度	≤10%
传输距离	≥10m	信噪比	> 80dB
输出功率	5W	喇叭参数	φ52mm 4Ω 5W
频响范围	50Hz-20kHz	电源输入	5V 1A
充电接口	Type-C	产品尺寸	113x113x188mm
内置锂电	3.7V/3600mAh		

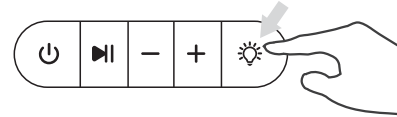



### 火焰灯使用



火焰灯和音箱是独立设计, 独立控制的, 短按火焰灯开关按键  一次, 火焰灯点亮, 再短按切换到夜灯功能, 再短按熄灭, 依次循环。长按  键可以调节夜灯的亮度。





### 音箱使用

#### 单音箱使用

- 长按  键开机, 并伴有提示音, 蓝色指示灯慢闪, 然后在手机端搜索音箱名称, 连接成功后指示灯长亮并有提示音。
- 短按  键切换到上一曲, 长按为减小音量。
- 短按  键切换到下一曲, 长按为增加音量, 音量最大时有提示音。
- 长按  键取消和手机配对。
- 短按  键暂停或继续播放。

#### 双音箱使用

#### 对箱配对组合

- 同时长按  键打开两台音箱的电源。短按或双击任意一台音箱的电源键  此时两台音箱在互相配对组合中, 配对组合成功后指示灯长亮并有提示音。
- 如果单个音箱已经和手机配对连接成功, 再想和另一音箱组合左右声道, 只需要打开另一音箱的电源, 然后在已经和手机配对连接的机子上, 短按或双击电源键  即可, 等待两个音箱自动配对组合, 配对组合成功后会有提示音。(一定要在先和手机配对连接的机子上短按或双击电源键  , 否则不能配对组合成功)

### 对箱使用

- 当对箱配对组合成功后, 和手机的连接操作同单音箱使用方法, 搜索名手机里只会显示一个, 和手机连接后声音即从两上音箱上同时出来。
- 如果只想使用单音箱, 直接关闭另一个的电源或长按  键取消配对组合即可。

### 充电说明

#### 电源输入

- 将USB连接线插入产品侧面USB插孔进行充电, 插入充电时亮红灯, 充满电后红灯熄灭

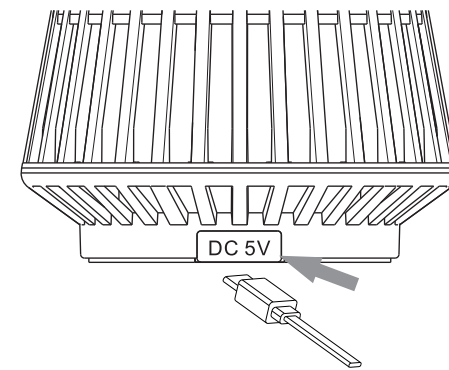

#### 注意事项

- 请在0°C-40°C的环境下充电
- 不建议外设产品边充电边使用
- 设备充满电后最好及时拔掉充电线
- 不要在潮湿的环境下给设备充电

## 产品售后服务保证卡

### FCC STATEMENT :

This device complies with Part 15 of the FCC Rules. Operation is subject to the following two conditions:  
(1) This device may not cause harmful interference, and  
(2) This device must accept any interference received, including interference that may cause undesired operation.

**Warning:** Changes or modifications not expressly approved by the party responsible for compliance could void the user's authority to operate the equipment.

**NOTE:** This equipment has been tested and found to comply with the limits for a Class B digital device, pursuant to Part 15 of the FCC Rules. These limits are designed to provide reasonable protection against harmful interference in a residential installation. This equipment generates uses and can radiate radio frequency energy and, if not installed and used in accordance with the instructions, may cause harmful interference to radio communications. However, there is no guarantee that interference will not occur in a particular installation. If this equipment does cause harmful interference to radio or television reception, which can be determined by turning the equipment off and on, the user is encouraged to try to correct the interference by one or more of the following measures:

Reorient or relocate the receiving antenna.  
Increase the separation between the equipment and receiver.  
Connect the equipment into an outlet on a circuit different from that to which the receiver is connected.  
Consult the dealer or an experienced radio/TV technician for help.

### 适用范围:

- 本产品自购买日起, 正常使用情况下保证一年免费服务。若超过保质期将收取一定零件成本费用。
- 如需更换零件的服务, 依照本公司服务零件检修价目表收费。
- 在下列情况时, 虽然在有效保证期间内, 恕不免费保证。
  - 1.因天灾地震、鼠祸公害、未正常使用所导致故障或损坏的。
  - 2.购买后的运送、移动落下、保存不当等所造成的故障或损坏。
  - 3.损耗品如零附件、电池、灯珠等。
  - 4.保证书信息记录不完全, 未填入购买日期、无购买店盖章的。
  - 5.特色环境不保修, 如潮湿、硫磺区、海边高盐分及船上等易腐蚀地区。
  - 6.未按照使用说明书使用者。
  - 7.特殊约定销售的产品。
- 产品返厂维修时, 送修时应自行妥善包装维修品, 以免在运送途中造成损害。
- 自行拆装产品导致的产品故障, 制造方概不负责。

### 重要!

感谢您购买本产品。

为保证您权益, 请妥善填写, 谢谢!!

姓名	
地址	
电话	
发票号码	
购买日期	
产品型号	
经销商	! 本栏请加盖经销商店章。
<b>注意</b> *请妥善保留您的产品保证书, 保修期需出示核对	

### 注意事项

- 为了使用者正确使用音箱, 确保音箱性能良好, 请认真阅读并遵守:
- 切勿严重撞击主机
- 切勿接触苯、稀释剂等化学药品
- 请不要靠近磁场、电场
- 请避开直射光线或发热器具
- 切勿自行拆卸、修理、改造

# 单页: 240\*140mm, 折后: 80\*140mm, 正反印刷

## Flame speaker

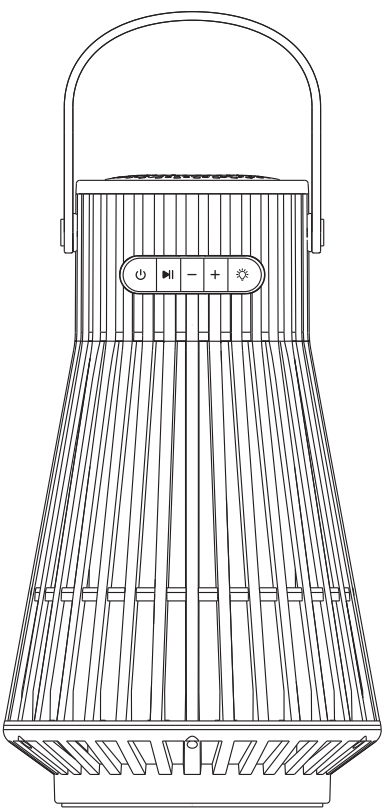

Please read carefully before use

### Product information





- Button control, easy to use
- Flame lamp
- Night light
- When using both two wireless speakers, the left and right channels be separated to be on the box. Stereo output creates perfect sound. (Notice: When using a single wireless speaker, the left and right channels will be combined to output.)
- Wireless speaker function
- White LED light flashes, shows wireless speaker is ON. White LED light lights in long time, shows wireless speaker connected success fully.
- When charging, it shows the red light. The red light goes off, shows the lamp full charged.
- IP65 dustproof and waterproof

### Technical Parameters

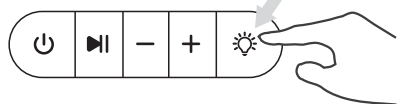
Wireless version	V5.0	Distortion Rate	≤10%
Output Power	5W	SNR	> 80dB
Transmission Distance	≥10m	Horn Parameters	φ52mm 4Ω 5W
Frequency Response	50Hz-20kHz	Power Supply	5V 1A
The Charging Interface	Type-C	Product Size	113x113x188mm
Built-in Lithium Battery	3.7V/3600mAh		





### Flame Lamp mode



Flame lamp and speaker are independently designed and controlled. Short press the light key  for the first time, and the flame light will turn on. Short press the light key  for the second time to turn on the night light, and long press the light key  to adjust the brightness or darkness of the night light. Short press the light key  for the third time, the night light goes out, and the cycle repeats in sequence.



### Wireless speaker mode

#### Single speaker use

- Long press  button to turn on speaker and with a beep. The blue indicator light flashes slowly, search bluetooth name "AJ100" on the phone. After the connection is successful, the indicator light will be always on and accompanied with a beep.
- Short press  button to switch to the previous song, long press to lower the volume.
- Short press  button to switch to next song, long press to increase the volume. When the volume reaches the maximum, there will be a beep.
- Long press  button to cancel pairing with mobile phone.
- Short press  button to pause or resume playing.

#### Double speakers use

#### Two speakers pairing

- Long press  button at same time to turn on the two speakers, short press or double press the  button of any speaker to enter the pairing. After the pairing is successful, the indicator light will be on and there will be a beep.
- If one speaker is successfully connected and to connect another one to form left and right channels, just turn on the left speaker power, and then short press or double press the  button of the connected speaker. After the pairing is successful, there will be a beep. (Be sure to short or double press the speakers that have been paired successfully, otherwise the pairing cannot be successfully combined).

### Double Speaker Use

- When the matching of the case is successful, the connection method of the mobile phone is the same as that of the single speaker. Only one search name will be displayed on the phone. After the connection is successful, the sound will come out from both speakers at the same time.
- If only want to use single speaker, directly turn off the power of the other or long press the  button to cancel the combination.

### Charging instructions

#### Power input

- Plug the USB into the USB port on the side of the speaker for charging, the red light will be on when charging, and it will go out when.

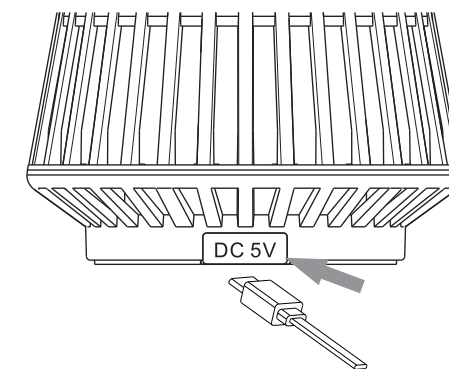

#### Attention

- Please charge in 0°C-40°C environment
- Not recommended to use while charging
- Please unplug the charging cable in time after fully charged
- Do not charge the speaker in a humid environment

## Warranty Card

### Applicable for

- Since buying date, the user enjoys one year free repair services under normal use. After one year, will be charged according to each component part cost.
- In case change component part, will be charged according to our company's component part cost list.
- The following situations without free repair services in warranty period
  - 1) Damage caused by natural earthquake, rat disaster, and unnormal use.
  - 2) Damage caused in transportation, fall, and improper storage.
  - 3) Consumable component, such as spare parts, batteries, light bulbs, etc.
  - 4) Warranty information records is not complete, no purchase date, no buying shop seal, etc.
  - 5) Featured using environment, such as humidity, sulfur area, high salty and on board, etc, easy corrosion area.
  - 6) Using not according to the instructions.
  - 7) Special offer.

- When return to factory for repair, the user should make sure the product packed properly to avoid any damage during transportation.
- Factory not responsible for the damages caused by the users themselves unproper disassemble.

### FCC STATEMENT :

This device complies with Part 15 of the FCC Rules. Operation is subject to the following two conditions:  
(1) This device may not cause harmful interference, and  
(2) This device must accept any interference received, including interference that may cause undesired operation.

**Warning:** Changes or modifications not expressly approved by the party responsible for compliance could void the user's authority to operate the equipment.

**NOTE:** This equipment has been tested and found to comply with the limits for a Class B digital device, pursuant to Part 15 of the FCC Rules. These limits are designed to provide reasonable protection against harmful interference in a residential installation. This equipment generates uses and can radiate radio frequency energy and, if not installed and used in accordance with the instructions, may cause harmful interference to radio communications. However, there is no guarantee that interference will not occur in a particular installation. If this equipment does cause harmful interference to radio or television reception, which can be determined by turning the equipment off and on, the user is encouraged to try to correct the interference by one or more of the following measures:

Reorient or relocate the receiving antenna.  
Increase the separation between the equipment and receiver.  
Connect the equipment into an outlet on a circuit different from that to which the receiver is connected.  
Consult the dealer or an experienced radio/TV technician for help.

### Important

Thank you for purchasing our products. To guarantee your rights, please fill in this form properly, Thank you

Name	
Address	
Telephone	
Invoice number	
Purchase date	
Item number	
Dealers	! Note: this field requires the dealer's seal!

Warning: please keep this warranty paper for repair presentation.

### Attention

- In order to use the speaker correctly, ensure the good performance of the speaker, please read carefully and observe below:
- Please do not impact the mainframe seriously
- Please do not contact benzene, diluent and other chemicals
- Please do not close to the magnetic and electric field
- Please avoid directly lighting and heating appliances
- Please do not repair, disassemble, transform by users themselves