

亞 驪 企 業 股 份 有 限 公 司
ARISTOTLE ENTERPRISES

承 認 申 請 書

客戶名稱: 捷超通訊科技股份有限公司
Customer
廠商料號: RFA-02-C2H1-06-150-白
Part No.
品名: 2.4GHz, 無鉛製程, 1.13,L=150mm
Description
圖號: RFA-02-C2H1-06-150-白.DWG
Drawing No.
客戶料號:
Drawing No.

出廠簽章:

檢 查 TEST BY	核 對 CHECK BY	承 認 APPROVE BY
周沂珮	黃秋芳	廖煥文

承認簽章:

檢 查 TEST BY	核 對 CHECK BY	承 認 APPROVE BY

地址:台北縣中和市莒光路 63 號 8 樓
電話:02-2225-8209
傳真:02-2225-7523

Specifications

Frequency range	2400 MHz – 2500 MHz
Antenna gain	2 dBi
VSWR	2.0 : 1 Max.
Polarization	Linear, vertical
Impedance	50 Ω
Temperature	- 10°C to +55°C
Connector	I-PEX
Cable	1.13

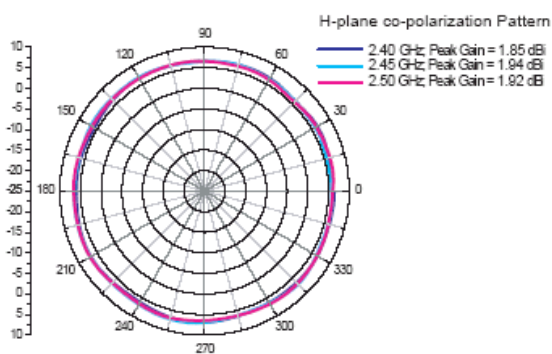
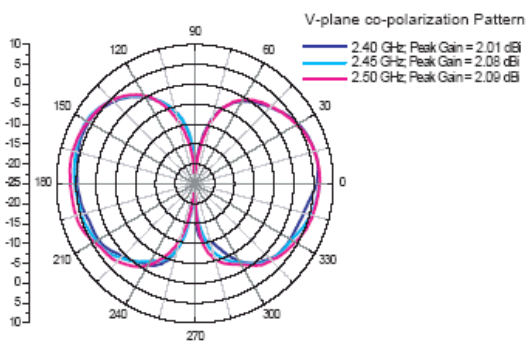

NO.	NAME	FINISH	MAT'L	Q'TY	MEMO
1.	Hinge	WHITE	ABS	1	
2.	Ant. Shell	WHITE	ABS	1	
3.	Cable	GRAY	TEFLON	1	OD=φ1.13
4.	Connector	GOLD PLATED	BRASS	1	20278-111R-13(I-PEX)

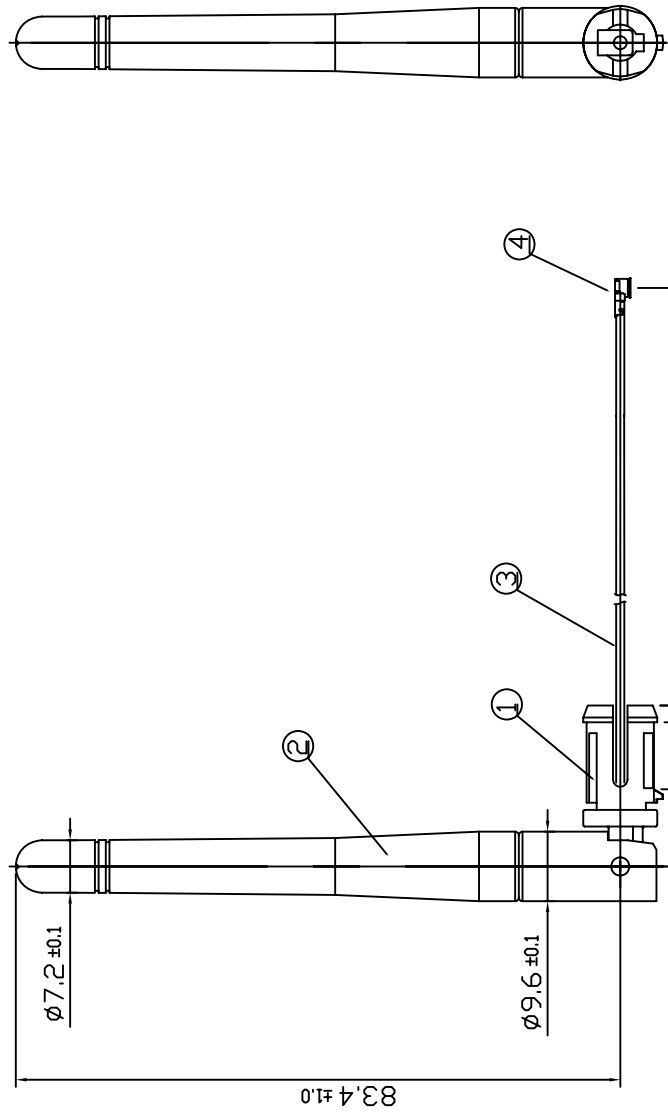

ARISTONTE
ENTERPRISES INC. 亞馬騰企業股份有限公司

PROJECTION	UNITS	mm	TITLE
	SCALE	1/1	RFA-02-C2H1-06-150-白
	PAPER	A4	2.4GHz, 平轉軸
APPD.			DWG NO.
CHKD.			REV.
DESIGN			RFA-02-C2H1-06-150-白DWG
DRAW			A

DATE: 23/02/05
DRAWN: J.W. Lee

REV	ECN	NAME	DATE
4.			
3.			
2.			
1.			

DESCRIPTION : Swivel Access Point Antenna

MODEL NO : RFA-02-C2H1-06-150-白

1.1 ELECTRICAL

Frequency Range: 2400~2500 MHZ

Gain: 2.0dBi

VSWR: ≤ 2

Polarization: Linear, Vertical

Impedance : 50Ω

Connector: IPEX MHF

Cable: φ 1.13mm

1.2 MECHANICAL

Condition : Non operating during test.

Material : PCABS(UL94V-0)

Endurance

Number of 90° rotation of the connector : 1000 cycles (min.)

Mandatory : Guaranty of functionalities after test.

Bending: Number of 90° at the hinge parts and bending on one direction with 1 kg force : 1000 cycles

Mandatory : No mechanical damage tolerated. Guaranty of functionalities after test.

Antenna resistance

Tests are applicable to all parts and both sides.

Traction: Tractions force applied 3 times on plugs during 15 second : 5 kg

Mandatory : No mechanical damage tolerated. Guaranty of functionalities after test.

1.3 ENVIROMENTAL

Storage

Condition : Non operating during test.

Cold: -40°C during 72h (IEC 68-2-1 standard Ab/Ad test)

Dry heat: +80°C during 96h (IEC 68-2-2 standard Bb/Bd test)

Humidity: +40°C at 95%R.H. during 4 days (IEC 68-2-56 standard Cb test)

Mandatory : No mechanical or visible damage tolerated. Guaranty of functionalities after test.

Operation

Condition : Operating during test.

Cold: -10°C during 48h (IEC 68-2-1 standard Ab/Ad test)

Dry heat: +55°C during 48h (IEC 68-2-2 standard Bb/Bd test)

Composite: -10°C to +55°C 95%R.H 4 cycles(IEC 68-2-30 standard Nb test)

Mandatory : No mechanical or visible damage tolerated. Guaranty of functionalities during and after test.



CHI MEI CORPORATION

59-1 SAN CHIA, JEN TE, TAINAN COUNTY, TAIWAN R.O.C.

TEL: 886-6-266-5000,

FAX: 886-6-266-5555-7

泛用級 ABS, POLYLAC[®] PA-757

VIW

材料特性

特性(Properties)	測試方法(Test Method)	測試條件(Test Condition)	單位(Unit)	PA-757
引張強度 Tensile Strength	ASTM D638	1/8", 6 mm/min	Kg/cm ² (lb/in ²)	480(6800)
延伸率 Tensile Elongation	ASTM D638	1/8", 6 mm/min	%	20
彎曲強度 Flexural Strength	ASTM D790	1/4", 2.8 mm/min	Kg/cm ² (lb/in ²)	820(11660)
彎曲彈性率 Flexural Modulus	ASTM D790	1/4", 2.8 mm/min	Kg/cm ² (lb/in ²)	27000(380000)
IZOD 衝擊強度 Izod Impact Strength	ASTM D256(Notched)	1/4", 23°C 1/8", 23°C	Kg-cm/cm(ft-lb/in) Kg-cm/cm(ft-lb/in)	18(3.3) 20(3.7)
流動係數 Melt Flow Index	ASTM D1238	200°C, 5Kg	g/10min	1.8
硬度 Hardness	ASTM D785	1/2"	R Scale	116
比重 Specific Gravity	ASTM D792	23°C	-	1.05
軟化點 Vicat Softening Temp	ASTM D1525	1/8", 50°C/hr	°C (°F)	105(221)
熱變形溫度 H.D.T Annealed(85°C, 8hr) Unannealed	ASTM D648	1/4", 120°C/hr	°C (°F)	99(210) 88(190)
燃燒率 Flammability	UL 94	-	-	1/16"HB

以上數據僅代表一般通用數據，不代表每一產品的規格值

若有任何疑問請洽產品推廣課 06-2665000, 06-2663000



奇美實業股份有限公司

台灣省台南縣仁德鄉三甲村59-1號。電話：886-6-266-5000，傳真：886-6-266-5555~7

1/2(A-GHE)

物質安全資料表

VIW

1. 物品及廠商資料

產品名稱	Polylac[®]	PA-707	PA-757	PA-757N	PA-717C	PA-727	PA-747	PA-709
製造商	奇美實業股份有限公司							
地址	台灣省台南縣仁德鄉三甲村59-1號							
電話	886-6-2663000		Ext. 1361 (產品推廣課)					
緊急電話	886-6-2663000		Ext. 1361 (產品推廣課)					
傳真電話	886-6-2667981							

2. 成品辨識資料

單一產品或混合物	單一產品
化學名稱	Acrylonitrile-Butadiene-Styrene Copolymer
含量	>98% (添加劑≤2%)
化學式	(C ₃ H ₃ N, C ₄ H ₆ , C ₈ H ₈) _x
CAS No.	9003-56-9
危害性不純物	無

3. 危害性分類

健康危害效應	無
環境影響	無
物理性及化學性危害	無
特殊危害	無

4. 急救措施

吸入	若吸入熔融樹脂逸出之氣體，將患者移至通風處，立即送醫。
皮膚接觸	若接觸到塑膠粒或塑膠粉末，以清水沖洗。 若接觸到熔膠，以大量(肥皂)水沖洗患部及衣物，立即送醫。
眼睛接觸	若接觸到塑膠粒或塑膠粉末，以大量清水至少沖洗15分鐘。 若有不適，立即送醫。 若接觸到高溫熔融樹脂逸出之氣體，以大量清水至少沖洗15分鐘。 若有不適，立即送醫。
吞食	催吐，以清水漱口，若有不適，立即送醫。

5. 消防措施

適用滅火劑	水、泡沫、乾粉
滅火時可能遭遇之特殊危害	無
特殊滅火程序	移除可燃物
消防人員之特殊防護設備	使用供氧式呼吸防護具

6. 洩漏處理方法

個人應注意事項	若塑膠粒或塑膠粉末殘留於地面上，可能會導致人員滑倒。
環境注意事項	為防止鳥類或魚類由排水系統中攝食，須徹底回收
清理方法	回收或廢棄

7. 安全處置與儲存方法

處置	操作處所須嚴禁煙火，做好整理整頓以避免粉塵累積。為防止塵爆，空氣輸送管路、袋濾器及儲槽須加裝靜電消除裝置，並確實接地。袋濾器之濾材採導電性材質。
儲存	存放於陰涼處所，避免直射陽光、雨淋及急速之溫差。儲存處嚴禁煙火



奇美實業股份有限公司

台灣省台南縣仁德鄉三甲村59-1號。電話：886-6-266-5000, 傳真：886-6-266-5555~7 2/2(A-GHE)

8. 暴露預防措施

容許濃度(TLV)	未定
通風設備	排除粉塵、煙及氣體時使用
個人防護設備	呼吸防護 清洗成型機時使用防毒面具。 手部防護 接觸熔膠時使用皮手套。 眼睛防護 平時使用安全眼鏡，清洗成型機時使用護目鏡

9. 物理及化學性質

物質狀態	米白色膠粒
形狀	粒狀
顏色	米白色
氣味	無
閃火點	404 °C
自燃溫度	466 °C
爆炸界限	45 g/m ³
最小著火能量	3.6 mJ
最大爆炸壓力	7 × 10 ⁵ Pa
最大壓力上升速度	3.2 × 10 ⁷ Pa/S
比重	1.03-1.10
溶解度	無

10. 安定性及反應性

安定性	依一般操作及儲存程序時，安定性佳。
危害性分解物	CO, HCN, AN, SM and NO
燃燒能量	3.53 × 10 ⁷ J/kg (8424 Kcal/kg)

11. 毒性資料

刺激性	分解後之塑膠所產生的煙及蒸氣會刺激眼睛。
-----	----------------------

12. 生態資料

為防止被海洋生物或鳥類攝食，嚴禁丟棄至海洋或水域。

13. 廢棄物處理

適當之焚化爐燃燒或掩埋法。不適當之焚化爐可能會產生有毒氣體如 CO, HCN, AN and SM.

14. 運送資料

未分類

15. 法規資料

無

16. 其他資料

無

CHI MEI CORPORATION

59-1 SAN CHIA JEN TE TAINAN HSIEN TAIWAN

Material Designation: PA-757 (+)

Product Description: Acrylonitrile Butadiene Styrene (ABS), designated "Polylac" furnished as pellets.

Color	Min. Thick. (mm)	Flame Class	HWI	HAI	RTI Elec	RTI Imp	RTI Str	IEC GWIT	IEC GWFI
ALL	1.5	HB	4	0	85	80	85	-	-
	3.0	HB	3	0	85	80	85	-	-
CTI: 0	IEC CTI: -	HVTR: 1			D495: 1			IEC Ball Pressure (°C): -	
Dielectric Strength (kV/mm): -					Volume Resistivity (10⁹ohm-cm): -			Dimensional Stability(%): -	
ISO Tensile Strength (MPa): -					ISO Flexural Strength (MPa): -			ISO Heat Deflection (°C): -	
ISO Tensile Impact (kJ/m²): -					ISO Izod Impact (kJ/m²): -			ISO Charpy Impact (kJ/m²): -	

(+) Optional prefix or suffix may be used to denote 0-0.5% acid scavengers.

Report Date: 6/23/1983

Underwriters Laboratories Inc®

UL94 small-scale test data does not pertain to building materials, furnishings and related contents. UL 94 small-scale test data is intended solely for determining the flammability of plastic materials used in components and parts of end-product devices and appliances, where the acceptability of the combination is determined by

ULI.



CHI MEI CORPORATION

59-1 SAN CHIA, JEN TE, TAINAN COUNTY, TAIWAN R.O.C. TEL: 886-6-266-5000, FAX: 886-6-266-5617

Data issued: May 25, 2005

We hereby certify that the follow Polyac ABS resin (list as follow) produced by Chi Mei Corporation

GP-Grade	PA-707, PA-757, PA-717C, PA-727, PA-747, PA-709,
HF-Grade	PA-756, PA-756S, PA-756H, PA-756B, PA-716, PA-746, PA-746H, PA-737
Extrusion Grade	PA-747F, PA-747R, PA-747S, PA-709S
HH-Grade	PA-777B, PA-777D, PA-777E
Transparent Grade	PA-758

conforms to the requirement that no chemicals as following are added.

1. PBBEs (Poly Bromo Bisphenyl Ethers)
2. PBBs (Poly Bromo Bisphenyls)
3. Ozone Depleting Chemicals(CFC's&HCFC'S)
4. Chlorinated Paraffin (C10-C13)
5. Polyvinyl Chloride (PVC)
6. Mercury(Hg) and its compounds,
7. Lead(Pb) and its compounds,
8. Cadmium(Cd) and its compounds,
9. Chromium(Cr) and its compounds,
10. Arsenic(As) and its compounds,
11. Antimony(Sb) and its compounds,
12. Selenium(Se) and its compounds,
13. Barium(Ba) and its compounds,
14. Chromium(Cr) VI and its compounds
15. Organic tin compounds
16. Polychlorinated Biphenyls(PCB's) and Terphenyls(PCT's)
17. Poly naphthalenes
18. Azo compounds
19. Polychlorinated biphenyl
20. Polychlorinated naphthalene
21. Asbestos
22. Phthalates

With regard to composition of above grade, they can comply with the Directives of RoHS (2002/95/EC), 2003/11/EC , TCO'99, Blue Angel and SONY (SS-00259)

Sincerely Yours,

Eric Chou

Manager

Department of Product Strategy & Service

This statement is based on our current level of knowledge and covers the above resins as supplied by CHI MEI CORPORATION at the date of issue. Since conditions of use are outside CHI MEI CORPORATION's control, CHI MEI CORPORATION makes no warranties, express or implied, and assumes no liability in connection with any use of this information.

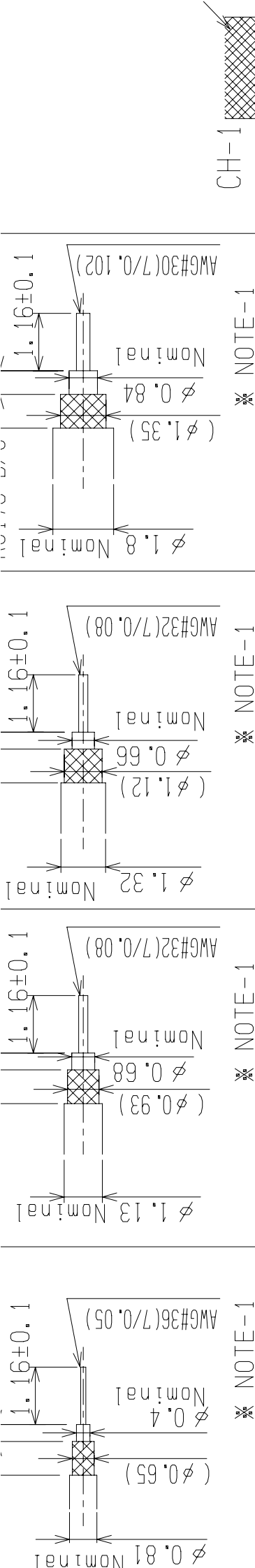
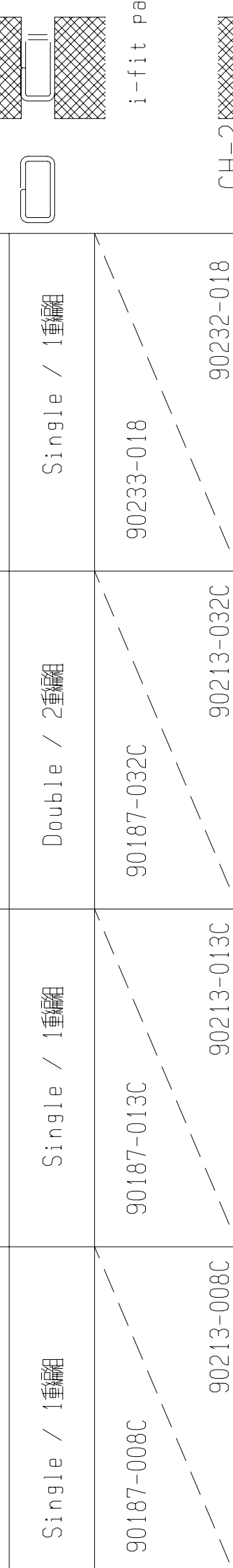
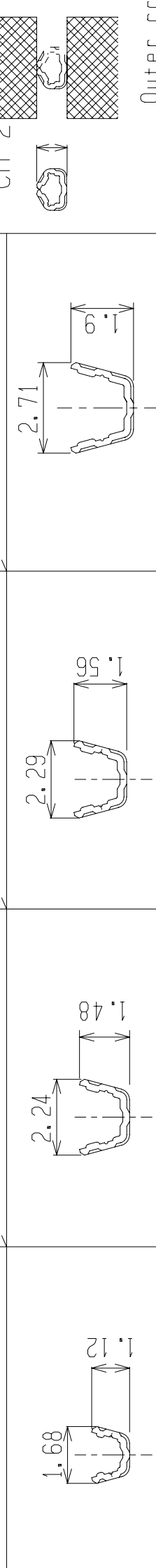
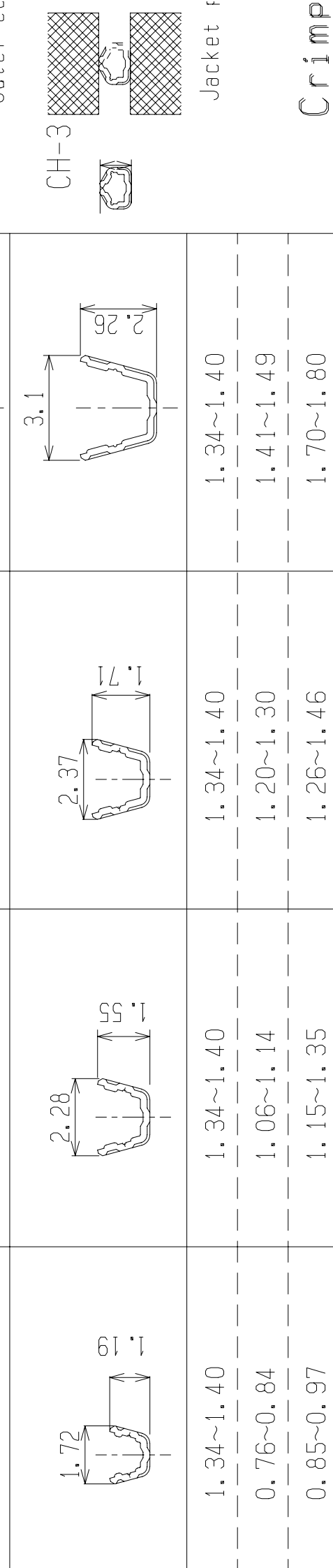
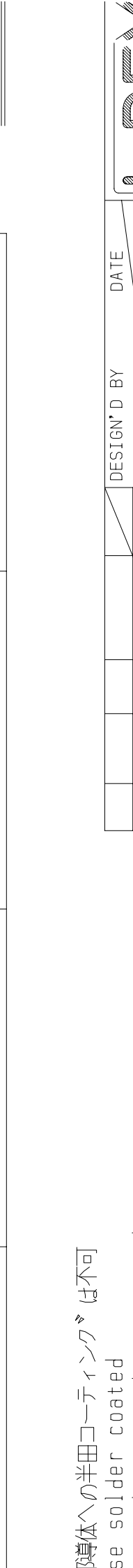
				
Single / 1重編組	Double / 2重編組	Single / 1重編組	Single / 1重編組	Single / 1重編組
90187-008C	90187-032C	90187-013C	90187-013C	90233-018
90213-008C	90213-032C	90213-013C	90213-013C	90232-018
1.34~1.40	1.34~1.40	1.34~1.40	1.34~1.40	1.34~1.40
0.76~0.84	1.20~1.30	1.06~1.14	1.06~1.14	1.41~1.49
0.85~0.97	1.26~1.46	1.15~1.35	1.15~1.35	1.70~1.80

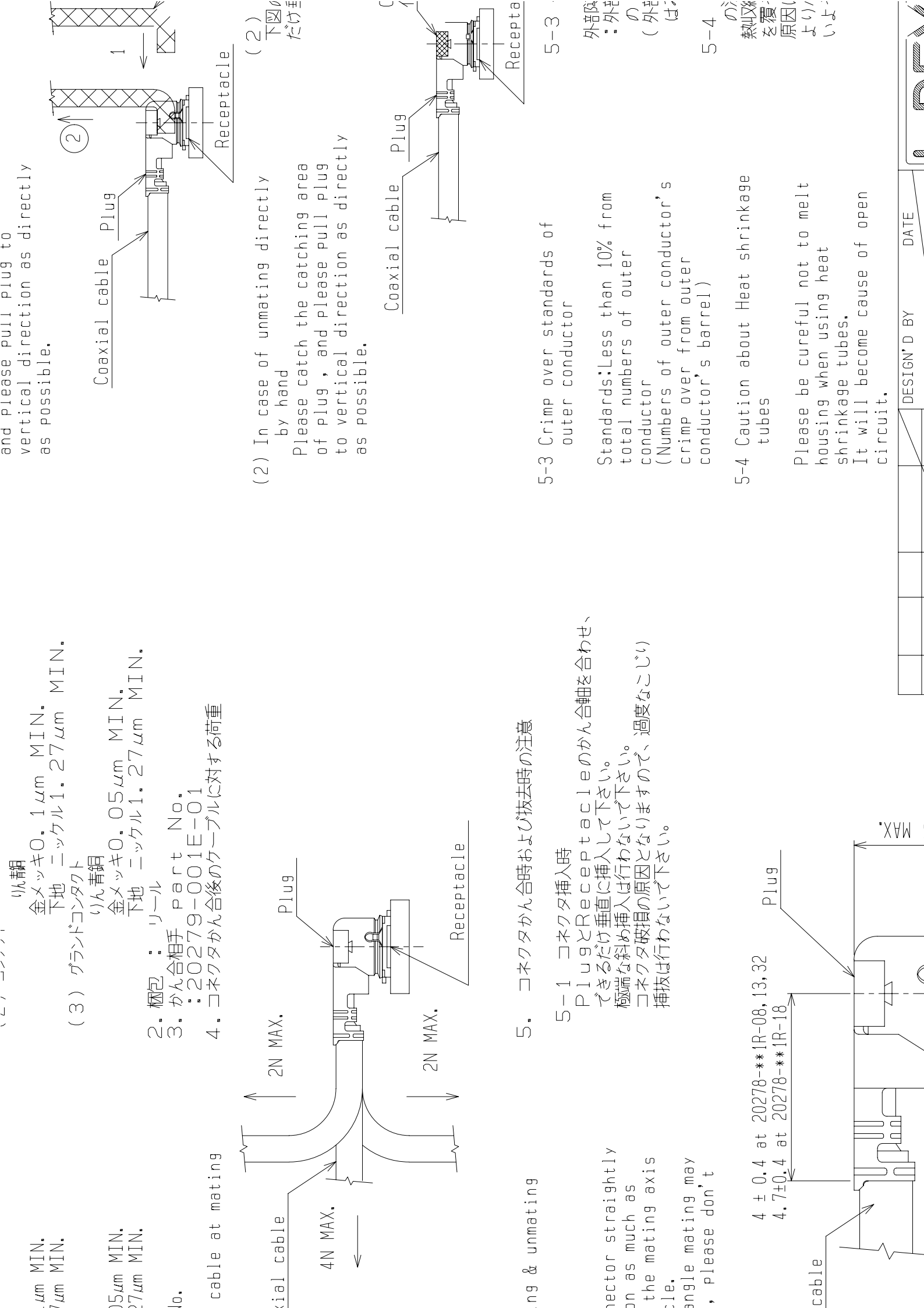

0.1mm MIN.
0.2mm MIN.

0.5mm MIN.
0.7mm MIN.

0.1mm MIN.
0.27mm MIN.

0.05mm MIN.
0.27mm MIN.

リール
Part No.
: 20279-001E-01

コネクタかん合後のケーブルに対する荷重

コネクタかん合時および抜去時の注意

コネクタ挿入時
PlugとReceptacleのかん合軸を合わせ、
できるだけ垂直に挿入して下さい。
極端な斜め挿入は行わないで下さい。
コネクタ破損の原因となりますので、過度なこじり
挿抜は行わないで下さい。

4 ± 0.4 at 20278-**1R-08, 13, 32
4.7 ± 0.4 at 20278-**1R-18

connector straightly
as much as
the mating axis
able.
angle mating may
, please don't

and please pull plug to
vertical direction as directly
as possible.

Coaxial cable Plug

Receptacle

Coaxial cable Plug

Receptacle

4N MAX.

2N MAX.

2N MAX.

5-3 Crimp over standards of
outer conductor

Standards: Less than 10% from
total numbers of outer
conductor
(Numbers of outer conductor's
crimp over from outer
conductor's barrel)

5-4 Caution about Heat shrinkage
tubes

Please be careful not to melt
housing when using heat
shrinkage tubes.
It will become cause of open
circuit.

5-3

5-4

外部腐
の
(外部
は、

熱収縮
を覆
原因
よ
いよ

DESIGN'D BY

DATE

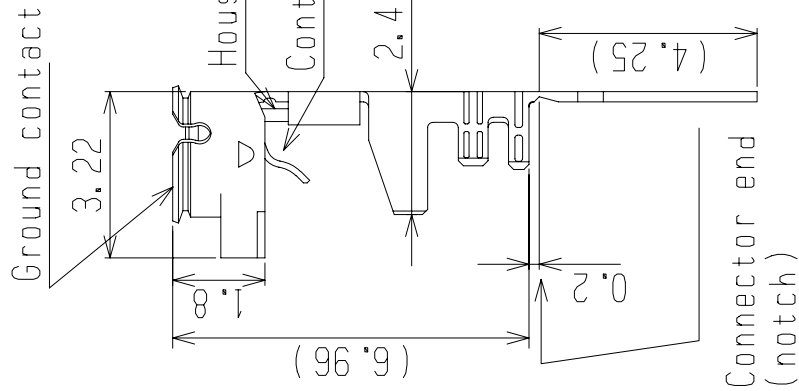
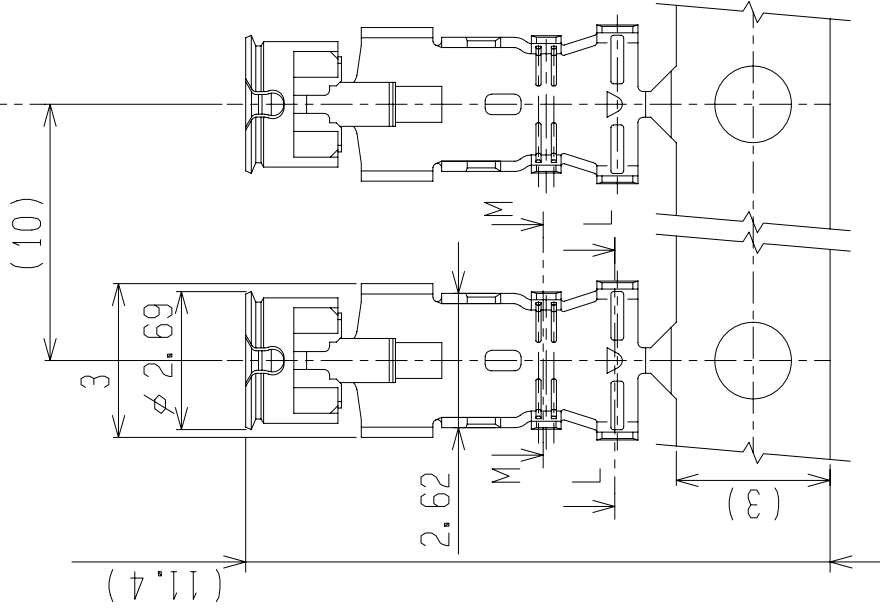
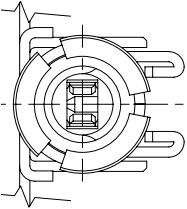

Part No. 20278-101R-08
20278-101R-13
20278-101R-32

For hand tool
(with notch)

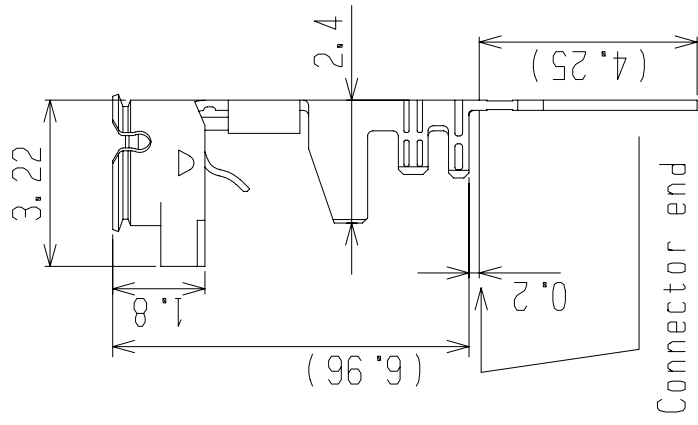

Part No. 20278-111R-08
20278-111R-13
20278-111R-32

For semi auto
termination machine
(without notch)

Date :

Our Spec. No. WS03-M051

MESSRS.

SPECIFICATION
FOR
HIGH FREQUENCY COAXIAL CABLE
" KHCX - 32AWG - SB - TA "

SHOWA ELECTRIC WIRE & CABLE CO., LTD.

TORANOMON

TOKYO JAPAN

James Huang

LANTRRA INDUSTRIAL CO., LTD.
F.14, NO. 92, SHING TEH ROAD,
SAN CHUNG, TAIPEI, TAIWAN
TEL:886-2-8511-1178
FAX:886-2-8511-1179
Email:sales@lanterra.com.tw
www.lanterra.com.tw
www.terraview.com.tw

T. Mori

T. Mori
Manager, Engineering Section
Engineering Dept.
Electronic Wire Business Unit

1. 適用(SCOPE)

本仕様書は電子機器などの内部配線に使用される細径同軸“KHCX-32AWG-SB-TA”の構造と特性について定める。

This specification covers the construction and characteristics of coaxial cable “KHCX-32AWG-SB-TA” for internal wiring of electronic equipment.

2. ケーブル型名の説明 (EXPLANATION OF CABLE TYPE)

KHCX-32AWG-SB-TA

(1) (2) (3)

(1) ケーブル略称 (Cable Abbreviation)

(2) 導体サイズ (Conductor Size)

(3) 外部導体タイプ (Outer Conductor Type)

3. 構造(CONSTRUCTION)

項目 Item		要求特性 Requirement
内部導体 Inner conductor	材質 Material	銀めつき軟銅線 Silver coated annealed copper wire
	構成 Stranding	7/0.08mm
	外径 Diameter	標準 0.24mm Nom. 0.24mm
絶縁体 Insulation	材質 Material	FEP
	色別 Color	自然色 Natural
	厚さ Thickness	標準 0.22mm Nom. 0.22mm
	外径 Diameter	標準 0.68mm Nom. 0.68mm
外部導体 Outer conductor	材質 Material	錫めつき軟銅線 Tinned annealed copper wire braid shield
	構成 Stranding	16/4/0.05 mm
シース Sheath	材質 Material	FEP
	色別 Color	灰・白・黒 Gray・White・Black
	厚さ Thickness	標準 0.10mm Nom. 0.10mm
仕上外径 Overall diameter		標準 1.13mm Nom. 1.13mm
概算質量 Approximate mass		3 kg/km

4. 電気特性(20℃) (ELECTRICAL CHARACTERISTICS at 20 degree)

項目 Item	単位 Unit	要求特性 Requirements
導体抵抗 Conductor Resistance	Ω/km	520 以下 Max. 520
絶縁抵抗 Insulation Resistance	MΩ km	1,500 以上 (DC 500V 1 分間充電後) Mjn. 1,500 (After charge DC 500V for 1 min.)
耐電圧 Dielectric Strength	V/1min.	AC 1,000
静電容量 Capacitance	pF/m	標準 97 (at 1kHz) Nom. 97 (at 1kHz)
特性インピーダンス Characteristic Impedance	Ω	標準 50 (TDR にて測定) Nom. 50 (at TDR)



図1.ケーブル構造図

Fig.1. Cable Cross-Section

5. 梱包及び荷札の表示 (PACKING AND MARKING ON TAG)

完成品は運送中及び保管中に損傷を生じぬ荷造りをする。

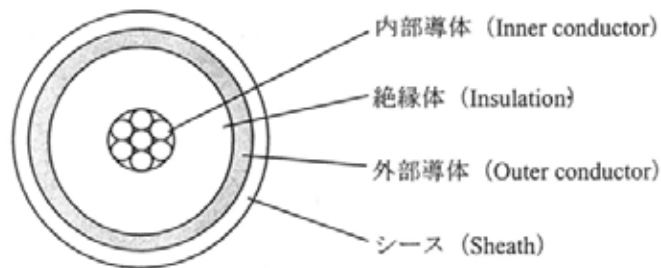
また、荷札の表示は以下の通りとする。

The completed cables shall be coiled and packing in such a manner as to be adequately protected from damage during packing, shipping, and normal handling.

The following items shall be marked in the Tag which is attached to the products.

- 1) 品名 (Type of Cable)
- 2) 導体サイズ (Conductor size)
- 3) 条長 (Length)
- 4) 製造者名または略称 (Manufacturer's name or trade mark)
- 5) 製造年月 (The year and month of manufacture)

なお、完成品にはジョイントを有する場合がある。その場合は条長明細を記載する。

Note : The spool may contain joints. In that case, the detail of length is indicated.

RoHS REPORT INDEX-RFA-02-C2H1-06-150-白

	NAME	供應商	RoHS report
1	ANTENNA HOUSING/HINGE-ABS PA757	CHI MEI CORPORATION	KA/2007/10032
2	IPEX	IPEX JP. CO., LTD.	CS/2006/90209
3	COAXIAL CABLE KHCX-Ø1.13		
3-1	GRAY PLASTIC JACKET	SWCC SHOWA DEVICE TECHNOLOGY CO., LTD.	CE/2006/B3245
3-2	SILVER COLORED METAL FOIL	SWCC SHOWA DEVICE TECHNOLOGY CO., LTD.	CE/2006/B3239C
3-3	TRANSPARENT PLASTIC	SWCC SHOWA DEVICE TECHNOLOGY CO., LTD.	CE/2006/B3239A
3-4	SILVER COLORED METAL WIRE	SWCC SHOWA DEVICE TECHNOLOGY CO., LTD.	CE/2006/B3239B

Test Report

No. :KA/2007/10032 Date: 20070109 Page: 1 of 5

CHI MEI CORPORATION.
NO.59-1, SANJIA VILLAGE, RENDE TOWNSHIP, TAINAN COUNTY 717, TAIWAN
(R.O.C.)



The following sample(s) was/were submitted and identified by/on behalf of the client as :

Sample Description : ACRYLONYTRILE-BUTADIENE-STYRENE COPOLYMER
Style/Item No. : POLYLAC® PA-757 J01
Color : BLACK
Sample Receiving Date : 2007/01/02
Testing Period : 2007/01/02 TO 2007/1/9

Test Requested : In accordance with the RoHS Directive 2002/95/EC, and its amendment directives.

Test Method :

- (1) With reference to US EPA 3052 for Cadmium Content. Analysis was performed by ICP-AES.
- (2) With reference to US EPA Method 3052 for Lead Content. Analysis was performed by ICP-AES.
- (3) With reference to US EPA Method 3052 for Mercury Content. Analysis was performed by ICP-AES.
- (4) With reference to IEC 62321, Ed.1 111/54/CDV. Determination of Hexavalent Chromium for non-metallic samples by UV/Vis Spectrometry.
- (5) With reference to US EPA 3540C for PBBs/PBDEs Content. Analysis was performed by GC/MS.

Test Result(s) : Please refer to next page(s).

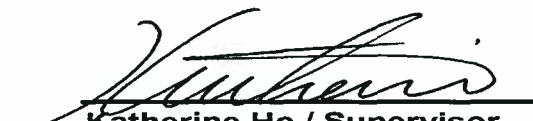

Katherine Ho / Supervisor
Signed for and on behalf of
SGS Taiwan Limited

This Test Report is issued by the Company subject to its General Conditions of Service printed overleaf or available on request and accessible at www.sgs.com. Attention is drawn to the limitations of liability, indemnification and jurisdictional issues defined therein. Unless otherwise stated the results shown in this test report refer only to the sample(s) tested. This test report cannot be reproduced, except in full, without prior written permission of the Company. Any unauthorized alteration, forgery or falsification of the content or appearance of this report is unlawful and offenders may be prosecuted to the fullest extent of the law. 此報告是遵循本公司訂定之通用服務條款所製作發放，請注意此條款列印於背面，亦可在www.sgs.com中查閱。將本公司之義務，免責，管轄權皆明確規範之。除非另有說明，此報告結果僅對檢驗之樣品負責。本報告未經本公司書面許可，不可部份複製。對本報告內容或外觀之任何未經授權之變更、偽造、竄改皆屬非法，違犯者將會被依法追訴。

TW4127728

Test Report

No. :KA/2007/10032

Date: 20070109 Page: 2 of 5

CHI MEI CORPORATION.
NO.59-1, SANJIA VILLAGE, RENDE TOWNSHIP, TAINAN COUNTY 717, TAIWAN
(R.O.C.)



Test results by chemical method (Unit: mg/kg)

Test Item (s):	Method (Refer to)	Result	MDL
		No.1	
Cadmium (Cd)	(1)	n.d.	2
Lead (Pb)	(2)	n.d.	2
Mercury (Hg)	(3)	n.d.	2
Hexavalent Chromium Cr(VI) by alkaline extraction	(4)	n.d.	2
Sum of PBBs	(5)	n.d.	-
Monobromobiphenyl		n.d.	5
Dibromobiphenyl		n.d.	5
Tribromobiphenyl		n.d.	5
Tetrabromobiphenyl		n.d.	5
Pentabromobiphenyl		n.d.	5
Hexabromobiphenyl		n.d.	5
Heptabromobiphenyl		n.d.	5
Octabromobiphenyl		n.d.	5
Nonabromobiphenyl		n.d.	5
Decabromobiphenyl		n.d.	5
Sum of PBDEs (Mono to Nona)(Note 4)		n.d.	-
Monobromobiphenyl ether		n.d.	5
Dibromobiphenyl ether		n.d.	5
Tribromobiphenyl ether		n.d.	5
Tetrabromobiphenyl ether		n.d.	5
Pentabromobiphenyl ether		n.d.	5
Hexabromobiphenyl ether		n.d.	5
Heptabromobiphenyl ether		n.d.	5
Octabromobiphenyl ether		n.d.	5
Nonabromobiphenyl ether		n.d.	5
Decabromobiphenyl ether		n.d.	5
Sum of PBDEs (Mono to Deca)		n.d.	-

TEST PART DESCRIPTION:

NO.1

: BLACK PLASTIC PELLETS

This Test Report is issued by the Company subject to its General Conditions of Service printed overleaf or available on request and accessible at www.sgs.com. Attention is drawn to the limitations of liability, indemnification and jurisdictional issues defined therein. Unless otherwise stated the results shown in this test report refer only to the sample(s) tested. This test report cannot be reproduced, except in full, without prior written permission of the Company. Any unauthorized alteration, forgery or falsification of the content or appearance of this report is unlawful and offenders may be prosecuted to the fullest extent of the law. 此報告是遵循本公司訂定之通用服務條款所製作發放，請注意此條款列印於背面，亦可在www.sgs.com中查閱。將本公司之義務，免責，管轄權皆明確規範之。除非另有說明，此報告結果僅對檢驗之樣品負責。本報告未經本公司書面許可，不可部份複製。對本報告內容或外觀之任何未經授權之變更、偽造、竄改皆屬非法，違犯者將會被依法追訴。

TW4127727

Test Report

No. :KA/2007/10032

Date: 20070109 Page: 3 of 5

CHI MEI CORPORATION.
NO.59-1, SANJIA VILLAGE, RENDE TOWNSHIP, TAINAN COUNTY 717, TAIWAN
(R.O.C.)



- Note :
1. mg/kg = ppm
 2. n.d. = Not Detected
 3. MDL = Method Detection Limit
 4. Sum of Mono to NonaBDE & according to 2005/717/EC DecaBDE is exempt.
 5. " - " = Not Regulated

This Test Report is issued by the Company subject to its General Conditions of Service printed overleaf or available on request and accessible at www.sgs.com. Attention is drawn to the limitations of liability, indemnification and jurisdictional issues defined therein. Unless otherwise stated the results shown in this test report refer only to the sample(s) tested. This test report cannot be reproduced, except in full, without prior written permission of the Company. Any unauthorized alteration, forgery or falsification of the content or appearance of this report is unlawful and offenders may be prosecuted to the fullest extent of the law. 此報告是遵循本公司訂定之通用服務條款所製作發放，請注意此條款列印於背面，亦可在www.sgs.com中查閱。將本公司之義務，免責，管轄權皆明確規範之。除非另有說明，此報告結果僅對檢驗之樣品負責。本報告未經本公司書面許可，不可部份複製。對本報告內容或外觀之任何未經授權之變更、偽造、竄改皆屬非法，違犯者將會被依法追訴。

TW4127726



Test Report

No. :KA/2007/10032 Date: 20070109 Page: 4 of 5

CHI MEI CORPORATION.
NO.59-1, SANJIA VILLAGE, RENDE TOWNSHIP, TAINAN COUNTY 717, TAIWAN
(R.O.C.)



Per requirements of SONY QAR-05-002:

1)These samples were dissolved totally by pre-conditioning method according to below flow chart.

2)Name of the person who made measurement: Hungming Li

3)Name of the person in charge of measurement: George Huang

Flow Chart of Digestion for Plastic –EPA3052 for Pb · Cd (without residue)

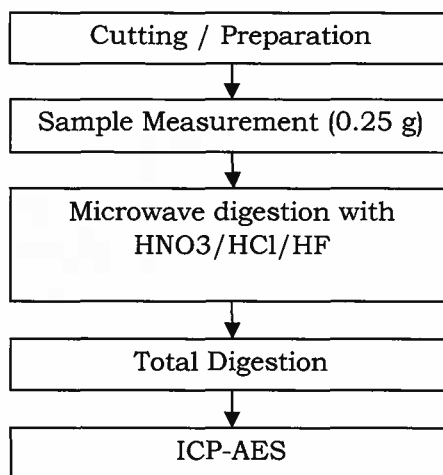

This Test Report is issued by the Company subject to its General Conditions of Service printed overleaf or available on request and accessible at www.sgs.com. Attention is drawn to the limitations of liability, indemnification and jurisdictional issues defined therein. Unless otherwise stated the results shown in this test report refer only to the sample(s) tested. This test report cannot be reproduced, except in full, without prior written permission of the Company. Any unauthorized alteration, forgery or falsification of the content or appearance of this report is unlawful and offenders may be prosecuted to the fullest extent of the law. 此報告是遵循本公司訂定之通用服務條款所製作發放，請注意此條款列印於背面，亦可在www.sgs.com中查閱。將本公司之義務，免責，管轄權皆明確規範之。除非另有說明，此報告結果僅對檢驗之樣品負責。本報告未經本公司書面許可，不可部份複製。對本報告內容或外觀之任何未經授權之變更、偽造、竄改皆屬非法，違犯者將會被依法追訴。

TW4127725

Test Report

No. :KA/2007/10032

Date: 20070109 Page: 5 of 5

CHI MEI CORPORATION.
NO.59-1, SANJIA VILLAGE, RENDE TOWNSHIP, TAINAN COUNTY 717, TAIWAN
(R.O.C.)



**** End of Report ****

This Test Report is issued by the Company subject to its General Conditions of Service printed overleaf or available on request and accessible at www.sgs.com. Attention is drawn to the limitations of liability, indemnification and jurisdictional issues defined therein. Unless otherwise stated the results shown in this test report refer only to the sample(s) tested. This test report cannot be reproduced, except in full, without prior written permission of the Company. Any unauthorized alteration, forgery or falsification of the content or appearance of this report is unlawful and offenders may be prosecuted to the fullest extent of the law. 此報告是遵循本公司訂定之通用服務條款所製作發放，請注意此條款列印於背面，亦可在www.sgs.com中查閱。將本公司之義務，免責，管轄權皆明確規範之。除非另有說明，此報告結果僅對檢驗之樣品負責。本報告未經本公司書面許可，不可部份複製。對本報告內容或外觀之任何未經授權之變更、偽造、竄改皆屬非法，違犯者將會被依法追訴。

TW4127724

Survey Report

I-PEX JP CO., LTD.
6-27-19 HARAMACHIDA MACHIDA-CITY TOKYO 194-
0013 JAPAN

Report No : CS/2006/90209

Date : 2006/09/22

Page : 1 of 4



The following sample(s) was/were submitted and identified by/on behalf of the client as :

Sample Description : MHF PLUG SERIE CONNECTOR
Style/Item No : 20278-111R-08, 20278-111R-13, 20278-111R-32, 20278-111R-18

=====
Test Result(s) : - Please see the next page(s) -

This report is combined with 4 copies of test reports which hereby certified by SGS through the verification of each above certification provided by client.

Daniel Yeh, M.R. / Operation Manager
Signed for and on behalf of
SGS TAIWAN LTD.

Survey Report

I-PEX JP CO., LTD.
6-27-19 HARAMACHIDA MACHIDA-CITY TOKYO 194-
0013 JAPAN

Report No : CS/2006/90209

Date : 2006/09/22

Page : 2 of 4



Test Result(s)

PART NAME NO.1 : GOLDEN COLORED METAL(CE/2005/A0701)
PART NAME NO.2 : GOLDEN COLORED METAL(CE/2005/96053)
PART NAME NO.3 : BLACK PLASTIC(CE/2005/96055)
PART NAME NO.4 : WHITE PLASTIC(CE/2006/60388)

Test Item(s):	Unit	Method	MDL	Result			
				NO.1	NO.2	NO.3	NO.4
Chromium VI (Cr+6)	ppm	UV-VIS after reference to US EPA 3060A.	2	N.D.	N.D.	N.D.	N.D.
Gold (Au)	ppm	ICP-AES after reference to US EPA 3050B or other acid digestion.	2	1155.0	3783.9	---	---
Cadmium (Cd)	ppm	ICP-AES after reference to EN 1122, method B:2001 or other acid digestion.	2	N.D.	N.D.	N.D.	N.D.
Mercury (Hg)	ppm	ICP-AES after reference to US EPA 3052 or other acid digestion.	2	N.D.	N.D.	N.D.	N.D.
Nickel (Ni)	ppm	ICP-AES after reference to US EPA 3050B or other acid digestion.	2	25445.3	33433.8	---	---
Lead (Pb)	ppm	ICP-AES after reference to US EPA 3050B or other acid digestion.	2	17.4	18.7	23.5	38.8

Survey Report

I-PEX JP CO., LTD.
6-27-19 HARAMACHIDA MACHIDA-CITY TOKYO 194-0013 JAPAN

Report No : CS/2006/90209

Date : 2006/09/22

Page : 3 of 4



Test Item(s):	Unit	Method	MDL	Result			
				NO.1	NO.2	NO.3	NO.4
Monobromobiphenyl	%	With reference to USEPA3540C. Analysis was performed by HPLC/DAD, LC/MS or GC/MS. (prohibited by 2002/95/EC (RoHS), 83/264/EEC, and 76/769/EEC)	0.0005	---	---	N.D.	N.D.
Dibromobiphenyl	%		0.0005	---	---	N.D.	N.D.
Tribromobiphenyl	%		0.0005	---	---	N.D.	N.D.
Tetrabromobiphenyl	%		0.0005	---	---	N.D.	N.D.
Pentabromobiphenyl	%		0.0005	---	---	N.D.	N.D.
Hexabromobiphenyl	%		0.0005	---	---	N.D.	N.D.
Heptabromobiphenyl	%		0.0005	---	---	N.D.	N.D.
Octabromobiphenyl	%		0.0005	---	---	N.D.	N.D.
Nonabromobiphenyl	%		0.0005	---	---	N.D.	N.D.
Decabromobiphenyl	%		0.0005	---	---	N.D.	N.D.
Total PBBs (Polybrominated biphenyls)/Sum of above	%	-	---	---	N.D.	N.D.	
Monobromobiphenyl ether	%	With reference to USEPA3540C. Analysis was performed by HPLC/DAD, LC/MS or GC/MS. (prohibited by 2002/95/EC (RoHS), 83/264/EEC, and 76/769/EEC)	0.0005	---	---	N.D.	N.D.
Dibromobiphenyl ether	%		0.0005	---	---	N.D.	N.D.
Tribromobiphenyl ether	%		0.0005	---	---	N.D.	N.D.
Tetrabromobiphenyl ether	%		0.0005	---	---	N.D.	N.D.
Pentabromobiphenyl ether	%		0.0005	---	---	N.D.	N.D.
Hexabromobiphenyl ether	%		0.0005	---	---	N.D.	N.D.
Heptabromobiphenyl ether	%		0.0005	---	---	N.D.	N.D.
Octabromobiphenyl ether	%		0.0005	---	---	N.D.	N.D.
Nonabromobiphenyl ether	%		0.0005	---	---	N.D.	N.D.
Decabromobiphenyl ether	%		0.0005	---	---	N.D.	N.D.
Total PBBEs(PBDEs) (Polybrominated biphenyl ethers)/Sum of above	%	-	---	---	N.D.	N.D.	
Total of Mono to Nona-brominated biphenyl ether. (Note 4)	%	-	---	---	N.D.	N.D.	

NOTE: (1) N.D. = Not Detected (<MDL)

(2) ppm = mg/kg

(3) MDL = Method Detection Limit

(4) Decabromodiphenyl ether (DecaBDE) in polymeric applications is exempted by Commission Decision of 13 Oct 2005 amending Directive 2002/95/EC notified under document 2005/717/EC.

(5) PBBEs=PBDEs=Polybrominated Diphenyl Ethers=PBDOs=PBBOs.

(6) " - " = Not Regulation

(7) " --- " = Not Applicable

Survey Report

I-PEX JP CO., LTD.
6-27-19 HARAMACHIDA MACHIDA-CITY TOKYO 194-
0013 JAPAN

Report No : CS/2006/90209

Date : 2006/09/22

Page : 4 of 4

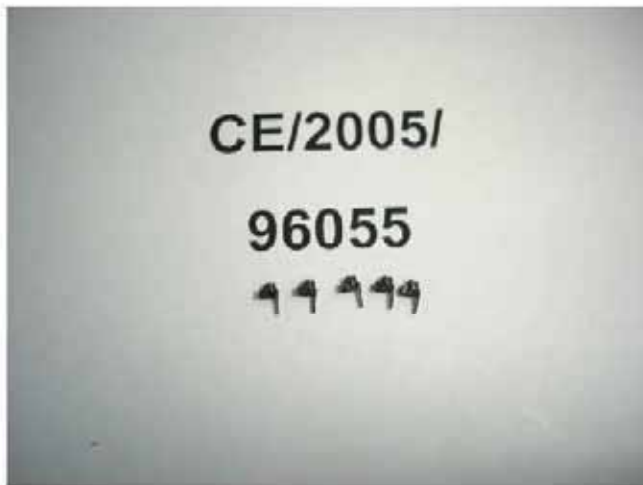
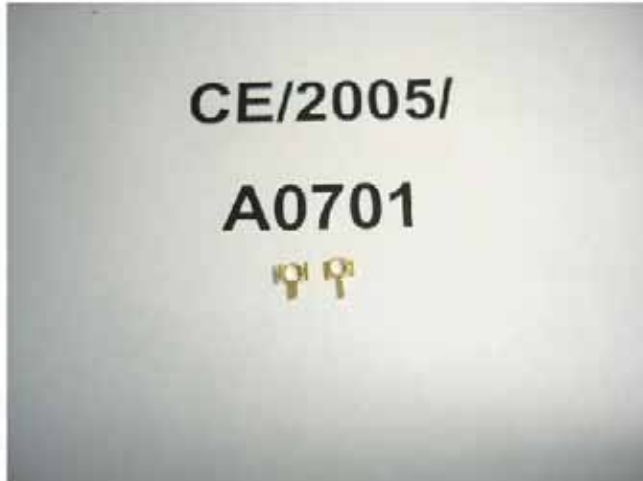

**** End of Report ****

Test Report

No : CE/2006/B3245 Date : 2006/11/21 Page: 1 of 3

SWCC SHOWA DEVICE TECHNOLOGY CO., LTD.
NO. 1-8, TORANOMON 1-CHOME, MINATO-KU, TOKYO
105-8444



Report on the submitted sample said to be ANTENNA COAXIAL CABLE UL-STYLE 11032.

Style/Item No : FOR KHCX-32AWG-SB-TA / KHCX-32AWG-WSB-TA /
KHCX-30AWG-SB-TA KHCX-36AWG-SB-TA GRAY
Sample Receiving Date : 2006/11/14
Testing Period : 2006/11/14 TO 2006/11/21

Test Requested : In accordance with the RoHS Directive 2002/95/EC, and its amendment directives.

Test Method :
(1) With reference to BS EN 1122:2001, Method B for Cadmium Content. Analysis was performed by ICP-AES.
(2) With reference to US EPA Method 3050B for Lead Content. Analysis was performed by ICP-AES.
(3) With reference to US EPA Method 3052 for Mercury Content. Analysis was performed by ICP-AES.
(4) With reference to US EPA Method 3060A & 7196A for Hexavalent Chromium. Analysis was performed by UV/Vis Spectrometry.
(5) With reference to US EPA 3540C for PBB/PBDE Content. Analysis was performed by GC/MS and screening via US EPA 3550C with HPLC/DAD/MS.

Test Result(s) : Please refer to next page(s).

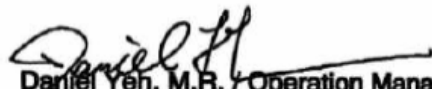
Daniel Yeh, M.R. / Operation Manager
Signed for and on behalf of
SGS TAIWAN LTD.

Test Report

No : CE/2006/B3245 Date : 2006/11/21 Page: 2 of 3

SWCC SHOWA DEVICE TECHNOLOGY CO., LTD.
NO. 1-8, TORANOMON 1-CHOME, MINATO-KU, TOKYO
105-8444



Test results by chemical method (Unit: mg/kg)

Test Item (s):	Method (Refer to)	Result	MDL
		No.1	
Cadmium (Cd)	(1)	n.d.	2
Lead (Pb)	(2)	n.d.	2
Mercury (Hg)	(3)	n.d.	2
Hexavalent Chromium (CrVI)	(4)	n.d.	2
Sum of PBBs	(5)	n.d.	-
Monobromobiphenyl		n.d.	5
Dibromobiphenyl		n.d.	5
Tribromobiphenyl		n.d.	5
Tetrabromobiphenyl		n.d.	5
Pentabromobiphenyl		n.d.	5
Hexabromobiphenyl		n.d.	5
Heptabromobiphenyl		n.d.	5
Octabromobiphenyl		n.d.	5
Nonabromobiphenyl		n.d.	5
Decabromobiphenyl		n.d.	5
Sum of PBDEs (Mono to Nona) (Note 4)		n.d.	-
Monobromobiphenyl ether		n.d.	5
Dibromobiphenyl ether		n.d.	5
Tribromobiphenyl ether		n.d.	5
Tetrabromobiphenyl ether		n.d.	5
Pentabromobiphenyl ether		n.d.	5
Hexabromobiphenyl ether		n.d.	5
Heptabromobiphenyl ether		n.d.	5
Octabromobiphenyl ether		n.d.	5
Nonabromobiphenyl ether		n.d.	5
Decabromobiphenyl ether		n.d.	5
Sum of PBDEs (Mono to Deca)		n.d.	-

Test Part Description:

NO.1 : GRAY PLASTIC JACKET

Note : 1. mg/kg = ppm

2. n.d. = Not Detected

3. MDL = Method Detection Limit

4. Sum of Mono to NonaBDE & according to 2005/717/EC DecaBDE is exempt.

5. "-" = Not Regulated

Test Report

No : CE/2006/B3245 Date : 2006/11/21 Page: 3 of 3

SWCC SHOWA DEVICE TECHNOLOGY CO., LTD.
NO. 1-8, TORANOMON 1-CHOME, MINATO-KU, TOKYO
105-8444



** End of Report **

Test Report

No : CE/2006/B3239C Date : 2006/11/28 Page: 1 of 3

SWCC SHOWA DEVICE TECHNOLOGY CO., LTD.
NO. 1-8, TORANOMON 1-CHOME, MINATO-KU, TOKYO
105-8444



Report on the submitted sample said to be ANTENNA COAXIAL CABLE UL-STYLE 11032.

Style/Item No : KHCX-32AWG-SB-TA KHCX-32AWG-WSB-TA
KHCX-30AWG-SB-TA KHCX-36AWG-SB-TA
Sample Receiving Date : 2006/11/14
Testing Period : 2006/11/14 TO 2006/11/21

=====
Test Requested : In accordance with the RoHS Directive 2002/95/EC, and its amendment directives.

Test Method :
(1) With reference to BS EN 1122:2001, Method B for Cadmium Content. Analysis was performed by ICP-AES.
(2) With reference to US EPA Method 3050B for Lead Content. Analysis was performed by ICP-AES.
(3) With reference to US EPA Method 3052 for Mercury Content. Analysis was performed by ICP-AES.
(4) With reference to US EPA Method 3060A & 7196A for Hexavalent Chromium. Analysis was performed by UV/Vis Spectrometry.

Test Result(s) : Please refer to next page(s).

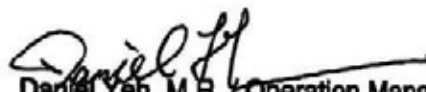
Daniel Yeh, M.R. / Operation Manager
Signed for and on behalf of
SGS TAIWAN LTD.

Test Report

No : CE/2006/B3239C Date : 2006/11/28 Page: 2 of 3

SWCC SHOWA DEVICE TECHNOLOGY CO., LTD.
 NO. 1-8, TORANOMON 1-CHOME, MINATO-KU, TOKYO
 105-8444



Test results by chemical method (Unit: mg/kg)

Test Item (s):	Method (Refer to)	Result	MDL
		No.1	
Cadmium (Cd)	(1)	n.d.	2
Lead (Pb)	(2)	n.d.	2
Mercury (Hg)	(3)	n.d.	2
Hexavalent Chromium (CrVI)	(4)	n.d.	2

Test Part Description:

NO.1 : SILVER COLORED METAL FOIL

- Note :
- 1. mg/kg = ppm
 - 2. n.d. = Not Detected
 - 3. MDL = Method Detection Limit

Test Report

No : CE/2006/B3239C Date : 2006/11/28 Page: 3 of 3

SWCC SHOWA DEVICE TECHNOLOGY CO., LTD.
NO. 1-8, TORANOMON 1-CHOME, MINATO-KU, TOKYO
105-8444



** End of Report **

Test Report

No : CE/2006/B3239A Date : 2006/11/28 Page: 1 of 3

SWCC SHOWA DEVICE TECHNOLOGY CO., LTD.
NO. 1-8, TORANOMON 1-CHOME, MINATO-KU, TOKYO
105-8444



Report on the submitted sample said to be ANTENNA COAXIAL CABLE UL-STYLE 11032.

Style/Item No : KHCX-32AWG-SB-TA KHCX-32AWG-WSB-TA
KHCX-30AWG-SB-TA KHCX-36AWG-SB-TA
Sample Receiving Date : 2006/11/14
Testing Period : 2006/11/14 TO 2006/11/21

=====
Test Requested : In accordance with the RoHS Directive 2002/95/EC, and its amendment directives.

Test Method :
(1) With reference to BS EN 1122:2001, Method B for Cadmium Content. Analysis was performed by ICP-AES.
(2) With reference to US EPA Method 3050B for Lead Content. Analysis was performed by ICP-AES.
(3) With reference to US EPA Method 3052 for Mercury Content. Analysis was performed by ICP-AES.
(4) With reference to US EPA Method 3060A & 7196A for Hexavalent Chromium. Analysis was performed by UV/Vis Spectrometry.
(5) With reference to US EPA 3540C for PBB/PBDE Content. Analysis was performed by GC/MS and screening via US EPA 3550C with HPLC/DAD/MS.

Test Result(s) : Please refer to next page(s).

Daniel Yeh, M.R. Operation Manager
Signed for and on behalf of
SGS TAIWAN LTD.

Test Report

No : CE/2006/B3239A Date : 2006/11/28 Page: 2 of 3

SWCC SHOWA DEVICE TECHNOLOGY CO., LTD.
NO. 1-8, TORANOMON 1-CHOME, MINATO-KU, TOKYO
105-8444



Test results by chemical method (Unit: mg/kg)

Test Item (s):	Method (Refer to)	Result	MDL
		No.1	
Cadmium (Cd)	(1)	n.d.	2
Lead (Pb)	(2)	n.d.	2
Mercury (Hg)	(3)	n.d.	2
Hexavalent Chromium (CrVI)	(4)	n.d.	2
Sum of PBBs	(5)	n.d.	-
Monobromobiphenyl		n.d.	5
Dibromobiphenyl		n.d.	5
Tribromobiphenyl		n.d.	5
Tetrabromobiphenyl		n.d.	5
Pentabromobiphenyl		n.d.	5
Hexabromobiphenyl		n.d.	5
Heptabromobiphenyl		n.d.	5
Octabromobiphenyl		n.d.	5
Nonabromobiphenyl		n.d.	5
Decabromobiphenyl		n.d.	5
Sum of PBDEs (Mono to Nona) (Note 4)		n.d.	-
Monobromobiphenyl ether		n.d.	5
Dibromobiphenyl ether		n.d.	5
Tribromobiphenyl ether		n.d.	5
Tetrabromobiphenyl ether		n.d.	5
Pentabromobiphenyl ether		n.d.	5
Hexabromobiphenyl ether		n.d.	5
Heptabromobiphenyl ether		n.d.	5
Octabromobiphenyl ether		n.d.	5
Nonabromobiphenyl ether		n.d.	5
Decabromobiphenyl ether		n.d.	5
Sum of PBDEs (Mono to Deca)		n.d.	-

Test Part Description:

NO.1 : TRANSPARENT PLASTIC

- Note :
1. mg/kg = ppm
 2. n.d. = Not Detected
 3. MDL = Method Detection Limit
 4. Sum of Mono to NonaBDE & according to 2005/717/EC DecaBDE is exempt.
 5. "-" = Not Regulated

Test Report

No : CE/2006/B3239A Date : 2006/11/28 Page: 3 of 3

SWCC SHOWA DEVICE TECHNOLOGY CO., LTD.
NO. 1-8, TORANOMON 1-CHOME, MINATO-KU, TOKYO
105-8444



**** End of Report ****

Test Report

No : CE/2006/B3239B Date : 2006/11/28 Page: 1 of 3

SWCC SHOWA DEVICE TECHNOLOGY CO., LTD.
NO. 1-8, TORANOMON 1-CHOME, MINATO-KU, TOKYO
105-8444



Report on the submitted sample said to be ANTENNA COAXIAL CABLE UL-STYLE 11032.

Style/Item No : KHCX-32AWG-SB-TA KHCX-32AWG-WSB-TA
KHCX-30AWG-SB-TA KHCX-36AWG-SB-TA
Sample Receiving Date : 2006/11/14
Testing Period : 2006/11/14 TO 2006/11/21

=====
Test Requested : In accordance with the RoHS Directive 2002/95/EC, and its amendment directives.

Test Method :
(1) With reference to BS EN 1122:2001, Method B for Cadmium Content. Analysis was performed by ICP-AES.
(2) With reference to US EPA Method 3050B for Lead Content. Analysis was performed by ICP-AES.
(3) With reference to US EPA Method 3052 for Mercury Content. Analysis was performed by ICP-AES.
(4) With reference to US EPA Method 3060A & 7196A for Hexavalent Chromium. Analysis was performed by UV/Vis Spectrometry.

Test Result(s) : Please refer to next page(s).

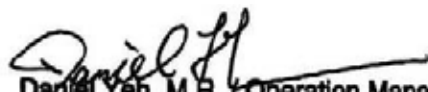
Daniel Yeh, M.R. / Operation Manager
Signed for and on behalf of
SGS TAIWAN LTD.

Test Report

No : CE/2006/B3239B Date : 2006/11/28 Page: 2 of 3

SWCC SHOWA DEVICE TECHNOLOGY CO., LTD.
 NO. 1-8, TORANOMON 1-CHOME, MINATO-KU, TOKYO
 105-8444



Test results by chemical method (Unit: mg/kg)

Test Item (s):	Method (Refer to)	Result	MDL
		No.1	
Cadmium (Cd)	(1)	n.d.	2
Lead (Pb)	(2)	n.d.	2
Mercury (Hg)	(3)	n.d.	2
Hexavalent Chromium (CrVI)	(4)	n.d.	2

Test Part Description:

NO.1 : SILVER COLORED METAL WIRE

- Note :
- 1. mg/kg = ppm
 - 2. n.d. = Not Detected
 - 3. MDL = Method Detection Limit

Test Report

No : CE/2006/B3239B Date : 2006/11/28 Page: 3 of 3

SWCC SHOWA DEVICE TECHNOLOGY CO., LTD.
NO. 1-8, TORANOMON 1-CHOME, MINATO-KU, TOKYO
105-8444



**** End of Report ****