



EMI TEST REPORT

Test Report No. : 27DE0139-HO-D

Applicant : OMRON Corporation Okayama factory
Type of Equipment : FA Wireless LAN Unit
Model No. : WE70-CL (applied model)
WE70-AP (tested model)
FCC ID : RXEWE70CL
Test standard : FCC Part 15 Subpart E: 2007
Section 15.407
Test Result : Complied

1. This test report shall not be reproduced in full or partial, without the written approval of UL Japan, Inc.
2. The results in this report apply only to the sample tested.
3. This sample tested is in compliance with above regulation.
4. The test results in this report are traceable to the national or international standards.

Date of test: January 19 to March 3, 2007

Tested by:

K. Adachi

Kenichi Adachi
EMC Services

M. Fujimura

Mitsuru Fujimura
EMC Services

T. Hatakedo

Takahiro Hatakedo
EMC Services

Approved by :

H. Shimoji

Hironobu Shimoji
Assistant Manager of
EMC Services



NVLAP LAB CODE: 200572-0

This laboratory is accredited by the NVLAP LAB CODE 200572-0, U.S.A. The tests reported herein have been performed in accordance with its terms of accreditation.
*As for the range of Accreditation in NVLAP, you may refer to the WEB address,
<http://uljapan.co.jp/emc/nvlap.htm>

UL Japan, Inc.

Head Office EMC Lab.

4383-326 Asama-cho, Ise-shi, Mie-ken 516-0021 JAPAN

Telephone : +81 596 24 8116

Facsimile : +81 596 24 8124

MF060b (18.06.07)

CONTENTS	PAGE
SECTION 1: Client information	3
SECTION 2: Equipment under test (E.U.T.)	3
SECTION 3: Test specification, procedures & results	5
SECTION 4: Operation of E.U.T. during testing	8
SECTION 5: Conducted Emission	11
SECTION 6: Spurious Emission , Band Edge Compliance	12
SECTION 7: 26dB Emission Bandwidth	13
SECTION 8: Maximum Peak Output Power	13
SECTION 9: Peak Power Spectral Density	13
SECTION 10: Peak Excursion Ratio	13
APPENDIX 1: Photographs of test setup	14
Conducted Emission	14
Spurious Emission (Radiated).....	16
Worst Case Position (Horizontal: EUT-X-axis, Ant-X-axis/ Vertical:EUT-X-axis, Ant-Y-axis)	17
APPENDIX 2: Data of EMI test	21
Conducted Emission	21
26dB Emission Bandwidth	42
Maximum Peak Output Power	45
Maximum Peak Output Power (Transmitter Power Control (Low power)).....	50
Radiated Spurious Emission (below 1GHz).....	52
Radiated Spurious Emission (above 1GHz:Inside of the restricted band)	67
Radiated Spurious Emission (above 1GHz:Outside of the restricted band).....	79
Conducted Spurious Emission(DSSS and other forms of modulation).....	97
Radiated emission Band Edge compliance.....	106
Conducted emission Band Edge compliance	109
Peak Power Spectral Density	110
Peak Excursion Ratio.....	113
99%Occupied Bandwidth.....	116
APPENDIX 3:Test instruments	118

SECTION 1: Client information

Company Name : OMRON Corporation Okayama factory
Address : 2075 Miyoshi Okayama-city, Okayama, 703-8502, Japan
Telephone Number : +81-86-276-1797
Facsimile Number : +81-86-276-1520
Contact Person : Shinji Ueno

SECTION 2: Equipment under test (E.U.T.)

2.1 Identification of E.U.T.

Type of Equipment : FA Wireless LAN Unit
Model No. : WE70-CL (applied model)
WE70-AP (tested model)*
Serial No. : 279651000201 (for Radiated Emission and Conducted Emission tests)
279651000202 (for Antenna Terminal Conducted test)
Rating : DC 24V (20.4V to 26.4V)
Country of Manufacture : JAPAN
Receipt Date of Sample : January 19, 2007
Condition of EUT : Production prototype
(Not for Sale: This sample is equivalent to mass-produced items.)
Modification of EUT : No modification by the test lab.

*As WE70-CL is identical to WE70-AP in radio specification, the test data for WE70-AP is included in this test report and used for the application of WE70-CL.

2.2 Product Description

Model No: WE70-CL is the, FA Wireless LAN Unit (Client).
WE70-CL has a variant model: WE70-AP (Master). They are identical in radio specification
The difference between two models is the presence or absence of RSSI button (for receiving status indication) only.
(WE70-AP does not have the button, but WE70-CL does.)

Clock Frequencies are 20MHz(CPU Clock), 25MHz(LAN Clock), 80MHz(Memory Clock) and 40MHz (Wireless LAN).

UL Japan, Inc.

Head Office EMC Lab.

4383-326 Asama-cho, Ise-shi, Mie-ken 516-0021 JAPAN

Telephone : +81 596 24 8116

Facsimile : +81 596 24 8124

IEEE802.11b / 11g / 11a WLAN

Equipment Type	Transceiver		
Frequency of Operation	11b/11g	2412MHz - 2462MHz *1)	
	11a	Low	5180MHz - 5240MHz
		Mid	5260MHz - 5320MHz *2)
		Add	5500MHz - 5700MHz *2)
		Upper	5745MHz - 5805MHz 5825MHz *1)
Type of Modulation	DSSS, DBPSK, DQPSK, CCK (11b) OFDM, BPSK, QPSK, 16QAM, 64QAM, CCK (11g, 11a)		
Bandwidth	20MHz		
Channel spacing	5MHz (11b/11g), 20MHz (11a)		
Power Supply (inner)	DC 3.3V		
Antenna Connector Type	Reverse SMA connector (ANT A and ANT B)		
Antenna Information	Type	: Dual Band Diversity Antenna	
	Model name	: ANT-S-789	
	Gain	: 2.14dBi (max)	
	Type	: Magnetic Pedestal Antenna *3)	
	Model name	: WE70-AT001H(OMR04-220100)	
	Gain	: 2.4GHz band: 4.5dBi (max) 5GHz band: 7dBi (max)	
	Type	: Magnetic Pedestal Antenna with extension cable of 5.0m *4)	
	Model name	: WE70-AT001H (OMR04-220100)	
	Gain	: 2.4GHz band: 4.5dBi (max) 5GHz band: 7dBi (max)	

*1) Refer to 27DE0139-HO-B, FCC Part 15C (FCC 15.247) report.

*2) Refer to 27DE0139-HO-F, FCC Part 15E (FCC 15.407 DFS) report.

*3) Magnetic Pedestal Antenna is connected directly with the cable of 2.0m.

*4) Magnetic Pedestal Antenna can be used with extension cable of 5.0 m (Total length of cable: 7.0m).

[Remarks]

The circuits for 2.4GHz and 5GHz bands are included in one chip of FA Wireless LAN Unit.

UL Japan, Inc.

Head Office EMC Lab.

4383-326 Asama-cho, Ise-shi, Mie-ken 516-0021 JAPAN

Telephone : +81 596 24 8116

Facsimile : +81 596 24 8124

SECTION 3: Test specification, procedures & results

3.1 Test Specification

Test Specification : FCC Part15 Subpart E : 2007
Title : FCC 47CFR Part15 Radio Frequency Device
Subpart E Unlicensed National Information Infrastructure Devices
Section 15.407 General technical requirements

FCC 15.31 (e)

This EUT provides stable voltage (DC3.3V) constantly to RF Module regardless of input voltage. Therefore, this EUT complies with the requirement.

FCC Part 15.407(d) Antenna requirement

This EUT complies with the requirement of 15.203, because a unique coupling (antenna connector, Type: Reverse SMA) is used for this EUT.

UL Japan, Inc.

Head Office EMC Lab.

4383-326 Asama-cho, Ise-shi, Mie-ken 516-0021 JAPAN

Telephone : +81 596 24 8116

Facsimile : +81 596 24 8124

3.2 Procedures and results

No.	Item	Test Procedure	Specification	Remarks	Deviation	Worst margin	Results
1	26dB Emission Bandwidth	FCC: ANSI C63.4:2003 IC: -	FCC : 15.407(a)(1)(2) IC: RSS-210 A9.2 (1) (2)	Conducted	N/A	See data	N/A
2	Maximum Peak Output Power	FCC: ANSI C63.4:2003 IC: -	FCC : 15.407(a)(1)(2) IC: RSS-210 A.9.2 (1) (2)	Conducted	N/A		Complied
3	Peak Power Spectral Density	FCC: ANSI C63.4:2003 IC: -	FCC : 15.407(a)(1)(2) IC: RSS-210 A.9.2 (1) (2)	Conducted	N/A		Complied
4	Peak Excursion Ratio	FCC: ANSI C63.4:2003 IC: -	FCC : 15.407(a)(1)(2)(3) IC: RSS-210 A.9.2 (1) (2)	Conducted	N/A		Complied
5	Spurious Emission	FCC: ANSI C63.4:2003 IC: -	FCC : 15.407(b)(1)(2)(4)(5)(7), 15.205 and 15.209 IC: RSS-210 A.9.3 (1) (2)	Conducted Radiated	N/A	[Tx] 2.5dB 62.501MHz Ver, QP (Tx 5180MHz) [Rx] 4.6dB 719.981MHz Hori, QP	Complied
6	Conducted Emission	FCC: ANSI C63.4:2003 IC: RSS-Gen 7.2.2	FCC: 15.407(b)(6)/15.207 IC: RSS-Gen 7.2.2	-	N/A	15.3dB 4.99554MHz AV, N (Tx 5700MHz)	Complied
7	Band Edge Compliance	FCC: ANSI C63.4:2003 IC: -	FCC : 15.407(b)(1)(2)(7)/15.205 IC: RSS-210 A.9.3 (1)(2)	Conducted / Radiated	N/A	See data	Complied
8	Dynamic Frequency Selection	FCC 06-96 APPENDIX IC: -	FCC : 15.407(h)(2) IC: RSS-210 A9.4	Conducted	N/A	N/A	N/A *1)

Note: UL Japan's EMI Work Procedures No.QPM05 and QPM15.

*1) Refer to 27DE0139-HO-F, FCC part 15E (FCC 15.407) DFS report.

*These tests were also referred to FCC Public Notice DA 02-2138 "Measurement Procedure Updated for Peak Transmit Power in the Unlicensed National Information Infrastructure (U-NII) Bands".

*These tests were performed without any deviations from test procedure except for additions or exclusions.

3.3 Addition to standards

No.	Item	Test Procedure	Specification	Remarks	Deviation	Worst margin	Results
1	99% Occupied Band Width	RSS-Gen 4.4.1	RSS-Gen 4.4.1	Conducted	N/A	N/A	N/A

UL Japan, Inc.

Head Office EMC Lab.

4383-326 Asama-cho, Ise-shi, Mie-ken 516-0021 JAPAN

Telephone : +81 596 24 8116

Facsimile : +81 596 24 8124

3.4 Uncertainty

The following uncertainties have been calculated to provide a confidence level of 95% using a coverage factor k=2.

Conducted Emission

The measurement uncertainty for this test is ± 2.66 dB.

The data listed in this test report has enough margin, more than the site margin.

Spurious Emission (Radiated)

The measurement uncertainty for this test using Biconical antenna is ± 4.59 dB(3m)/ ± 4.58 dB(10m).

The measurement uncertainty for this test using Logperiodic antenna is ± 4.62 dB(3m)/ ± 4.60 dB(10m).

The measurement uncertainty for this test using Horn antenna is ± 5.27 dB.

The data listed in this report meets the limits unless the uncertainty is taken into consideration.

Other test except Conducted Emission and Spurious Emission (Radiated)

The measurement uncertainty for this test is ± 3.0 dB.

3.5 Test Location

UL Japan, Inc. Head Office EMC Lab. *NVLAP Lab. code: 200572-0

4383-326 Asama-cho, Ise-shi, Mie-ken 516-0021 JAPAN

Telephone : +81 596 24 8116 Facsimile : +81 596 24 8124

	FCC Registration Number	IC Registration Number	Width x Depth x Height (m)	Size of reference ground plane (m) / horizontal conducting plane	Other rooms
No.1 semi-anechoic chamber	313583	IC4247A	19.2 x 11.2 x 7.7m	7.0 x 6.0m	Preparation room
No.2 semi-anechoic chamber	655103	IC4247A-2	7.5 x 5.8 x 5.2m	4.0 x 4.0m	-
No.3 semi-anechoic chamber	148738	IC4247A-3	12.0 x 8.5 x 5.9m	6.8 x 5.75m	
No.3 shielded room	-	-	4.0 x 6.0 x 2.7m	N/A	-
No.4 semi-anechoic chamber	134570	IC4247A-4	12.0 x 8.5 x 5.9m	6.8 x 5.75m	-
No.4 shielded room	-	-	4.0 x 6.0 x 2.7m	N/A	-
No.5 semi-anechoic chamber	-	-	6.0 x 6.0 x 3.9m	N/A	-
No.6 shielded room	-	-	4.0 x 4.5 x 2.7m	2.0 x 2.0 m	-
No.6 measurement room	-	-	4.75 x 5.4 x 3.0m	4.75 x 5.4 m	-
No.7 shielded room	-	-	4.7 x 7.5 x 2.7m	4.7 x 7.5m	-
No.8 measurement room	-	-	3.1 x 5.0 x 2.7m	N/A	-

* Size of vertical conducting plane (for Conducted Emission test) : 2.0 x 2.0m for No.1, No.2, No.3 and No.4 semi-anechoic chambers and No.3 and No.4 shielded rooms.

Our company name was changed from "UL Apex Co., Ltd." to "UL Japan, Inc." on April 26,2007.

3.6 Test set up, Test instruments and Data of EMI

Refer to APPENDIX 1 to 3.

UL Japan, Inc.

Head Office EMC Lab.

4383-326 Asama-cho, Ise-shi, Mie-ken 516-0021 JAPAN

Telephone : +81 596 24 8116

Facsimile : +81 596 24 8124

SECTION 4: Operation of E.U.T. during testing

4.1 Operating Modes

The mode is used :

The EUT was operating in a manner similar to typical use during the tests.

IEEE 802.11a : OFDM(54Mbps(Worst), Packet Type: Maximum, Payload: PN9) * See Remarks.

-Transmitting mode

- Channel 36: : 5180MHz
- Channel 52: : 5260MHz
- Channel 64: : 5320MHz

- Channel 100: : 5500MHz
- Channel 120: : 5600MHz
- Channel 140: : 5700MHz

- Channel 149: : 5745MHz
- Channel 153: : 5765MHz
- Channel 161: : 5805MHz

-Receiving mode

- Channel 52: : 5260MHz
- Channel 120: : 5600MHz
- Channel 153: : 5765MHz

Remarks

- Conditions : 1) Data Rate:IEEE802.11a : 6, 9, 12, 18, 24, 36, 48, 54 Mbps
2) Antenna connector: ANT A and ANTB (same type)
3) Antenna Type: Dual Band Diversity Antenna
Magnetic Pedestal Antenna
Magnetic Pedestal Antenna with extension cable 5m
4) High / Mid / Low power

As a result of the preliminary test, the final test was performed under the worst conditions of the above. See the below table for the details of the worst conditions.

Worst Conditions:

Test Item	IEEE802.11a
All tests	1) Rate: 54Mbps
	2) Antenna Port: ANT A
	3) Dual Band Diversity Antenna
	4) High power

However, some test items were performed with other antennas in addition to the worst one (Dual Band Diversity Antenna). See the below table for the details.

Test Item	Tested Antenna Type
Spurious emissions (Tx 5260MHz, 5600MHz, and 5765MHz)	Dual Band Diversity Antenna Magnetic Pedestal Antenna
BandEdge emissions (Tx 5180MHz, 5320MHz, 5500MHz, 5700MHz, 5745MHz, and 5805MHz)	Dual Band Diversity Antenna Magnetic Pedestal Antenna Magnetic Pedestal Antenna with extension cable 5m

UL Japan, Inc.

Head Office EMC Lab.

4383-326 Asama-cho, Ise-shi, Mie-ken 516-0021 JAPAN

Telephone : +81 596 24 8116

Facsimile : +81 596 24 8124

4.2 Configuration and peripherals

4.2.1 Conducted emissions /Antenna Terminal Conducted test

(1) Dual Band Diversity Antenna

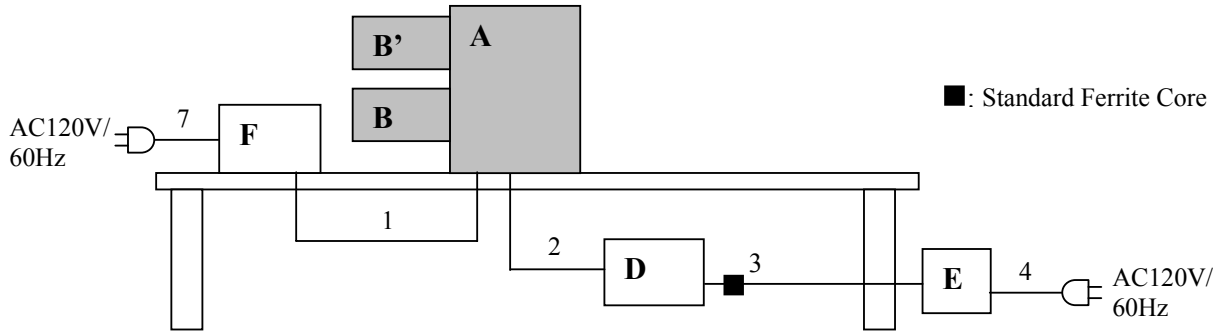

(2) Magnetic Pedestal Antenna

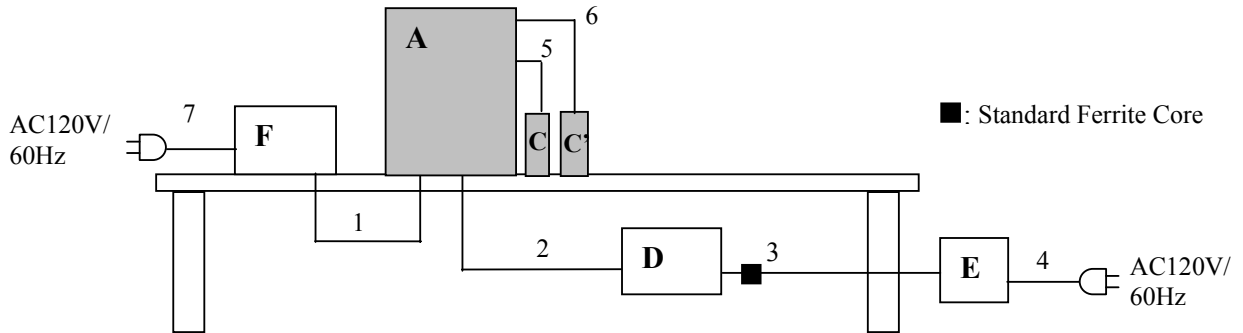

* Cabling and setup were taken into consideration and test data was taken under worse case conditions.

4.2.2 Radiated emissions

(1) Dual Band Diversity Antenna

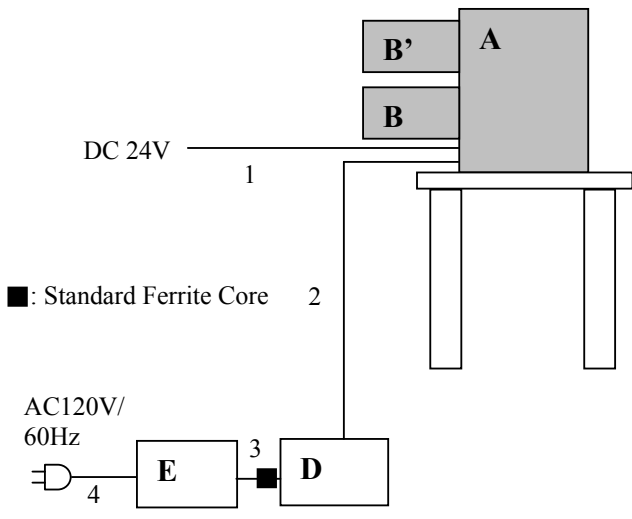

(2) Magnetic Pedestal Antenna

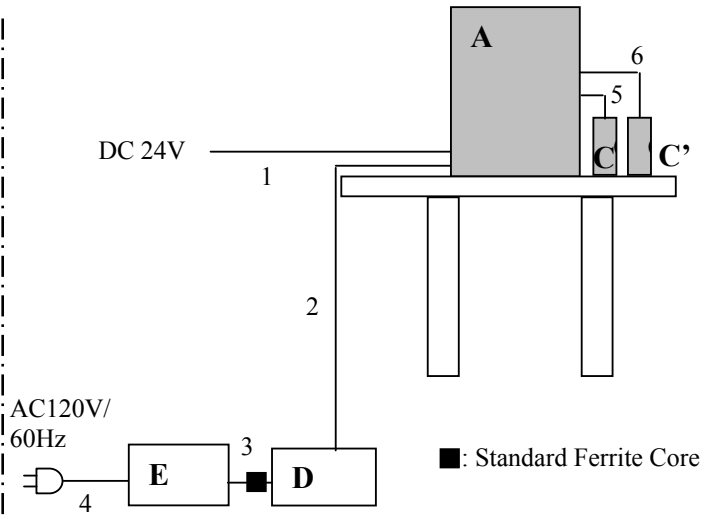

* Cabling and setup were taken into consideration and test data was taken under worse case conditions.

UL Japan, Inc.

Head Office EMC Lab.

4383-326 Asama-cho, Ise-shi, Mie-ken 516-0021 JAPAN

Telephone : +81 596 24 8116

Facsimile : +81 596 24 8124

Description of EUT and Support equipment

No.	Item	Model number	Serial number	Manufacturer	Remark
A	FA Wireless LAN Unit	WE70-AP	279651000201 *1) 279651000202 *2)	OMRON	EUT
B,B'	Dual Band Diversity Antenna	-	-	OMRON	EUT
C,C'	Magnetic Pedestal Antenna	-	-	OMRON	EUT
D	Personal Computer	TYPE2366-LJ7	97-99D4L	IBM	-
E	AC Adapter	02K6750	11S02K6750Z1Z2UP29ADTJ	IBM	-
F	DC power supply	6654A	MY40000510	Agilent	-

*1) for Conducted Emission and Radiated Emission tests.

*2) for Antenna Terminal Conducted test

List of cables used

No.	Name	Length (m)	Shield	
			Cable	Connector
1	DC cable	2.5	Unshielded	Unshielded
2	LAN cable	3.0	Shielded	Shielded
3	DC cable	1.8	Unshielded	Unshielded
4	AC cable	1.0	Unshielded	Unshielded
5	Antenna cable	2.0, 7.0 *3)	Shielded	Shielded
6	Antenna cable	2.0, 7.0 *3)	Shielded	Shielded
7	AC cable	2.2	Unshielded	Unshielded

*3) Without extension cable of 5.0m = 2.0m, With extension cable of 5.0m = 7.0m (2.0m + 5.0m.)

UL Japan, Inc.

Head Office EMC Lab.

4383-326 Asama-cho, Ise-shi, Mie-ken 516-0021 JAPAN

Telephone : +81 596 24 8116

Facsimile : +81 596 24 8124

SECTION 5: Conducted Emission

Test Procedure

EUT was placed on a urethane platform of nominal size, 1.0m by 1.5m, raised 80cm above the conducting ground plane.

The rear of tabletop was located 40cm to the vertical conducting plane. The rear of EUT, including peripherals aligned and flushed with rear of tabletop. All other surfaces of tabletop were at least 80cm from any other grounded conducting surface. EUT was located 80cm from a Line Impedance Stabilization Network (LISN)/ Artificial mains Network (AMN) and excess AC cable was bundled in center .

For the tests on EUT with other peripherals (as a whole system)

I/O cable and AC cables that were connected to the peripherals were bundled in center. They were folded back and forth forming a bundle 30cm to 40cm long and were hanged at a 40cm height to the ground plane.

The AC Mains Terminal Continuous disturbance Voltage has been measured with the EUT in a Semi Anechoic Chamber or a Measurement Room.

The EUT was connected to a LISN (AMN).

An overview sweep with peak detection has been performed.

The measurements have been performed with a CISPR quasi-peak detector (IF BW 9 kHz).

Measurement range: 0.15-30MHz

Test data : **APPENDIX 2**
Test result : **Pass**

UL Japan, Inc.

Head Office EMC Lab.

4383-326 Asama-cho, Ise-shi, Mie-ken 516-0021 JAPAN

Telephone : +81 596 24 8116

Facsimile : +81 596 24 8124

SECTION 6: Spurious Emission , Band Edge Compliance

[Conducted]

Test Procedure

The Out of Band Emission was measured with a spectrum analyzer connected to the antenna port.

Test data : APPENDIX 2
Test result : Pass

[Radiated]

Test Procedure

EUT was placed on a urethane platform of nominal size, 0.5m by 1.0m, raised 80cm above the conducting ground plane.

The Radiated Electric Field Strength intensity has been measured in a Semi Anechoic Chamber with a ground plane and at a distance of 3m(Below 10GHz) , 1m(10-26.5GHz, Distance Factor : $20\log(3[m]/1[m])$) and 0.5m(Upper 26.5GHz, Distance Factor : $20\log(3[m]/0.5[m])$).

The height of the measuring varied between 1 and 4m and EUT was rotated a full revolution in order to obtain the maximum value of the electric field intensity.

The measurements were performed for both vertical and horizontal antenna polarization with the Test Receiver or the Spectrum Analyzer.

Below 1GHz

The result also satisfied with the general limits specified in section 15.209(a).

Above 1GHz

Inside of the restricted bands (Section 15.205) : Apply to limit in the Section 15.209(a)

Outside of the restricted bands (Section 15.407) : Limit -27dBm EIRP
 -17dBm EIRP (5.725-5.825GHz Band Edge)

Frequency	Below 1GHz	Above 1GHz (Inside of the restricted bands)	Above 1GHz (Outside of the restricted bands)
Instrument use	Test Receiver	Spectrum Analyzer	Spectrum Analyzer
Detector IF Bandwidth	QP: BW 120kHz	PK: RBW:1MHz/VBW: 1MHz AV: RBW:1MHz/VBW:10Hz	RBW:1MHz/VBW: 1MHz

*The noise from the EUT was not seen above 18GHz. The measurement was made in the residual noise levels.

- The carrier level and noise levels were confirmed at each position of X, Y and Z axes of EUT and EUT's antenna to see the position of maximum noise, and the test was made at the position that has the maximum noise.

Test data : APPENDIX 2
Test result : Pass

UL Japan, Inc.

Head Office EMC Lab.

4383-326 Asama-cho, Ise-shi, Mie-ken 516-0021 JAPAN

Telephone : +81 596 24 8116

Facsimile : +81 596 24 8124

SECTION 7: 26dB Emission Bandwidth

Test Procedure

The 26dB Emission Bandwidth was measured with a spectrum analyzer connected to the antenna port.

Test data : APPENDIX 2
Test result : Pass

SECTION 8: Maximum Peak Output Power

Test Procedure

The Peak Transmit Power was measured with a spectrum analyzer connected to the antenna port. The test was made with the spectrum analyzer that has a function of channel-power measurement. We followed the method 1 specified in DA-02-2138A1.

Test data : APPENDIX 2
Test result : Pass

SECTION 9: Peak Power Spectral Density

Test Procedure

The Peak Power Spectral Density was measured with a spectrum analyzer connected to the antenna port. We followed the method 2 specified in DA-02-2138A1.

Test data : APPENDIX 2
Test result : Pass

SECTION 10: Peak Excursion Ratio

Test Procedure

The Peak Excursion Ratio was measured with a spectrum analyzer connected to the antenna port. The second Sweep was measured based on Method 1 specified in DA-02-2138A1.

Test data : APPENDIX 2
Test result : Pass

UL Japan, Inc.

Head Office EMC Lab.

4383-326 Asama-cho, Ise-shi, Mie-ken 516-0021 JAPAN

Telephone : +81 596 24 8116

Facsimile : +81 596 24 8124