



# RADIO TEST REPORT

Test Report No. : 27DE0139-HO-B

Applicant : OMRON Corporation Okayama factory  
Type of Equipment : FA Wireless LAN Unit  
Model No. : WE70-CL (applied model)  
WE70-AP (tested model)  
FCC ID : RXEWE70CL  
Test standard : FCC Part 15 Subpart C: 2007  
Section 15.207, Section 15.247  
Test Result : Complied

1. This test report shall not be reproduced in full or partial, without the written approval of UL Japan, Inc.
2. The results in this report apply only to the sample tested.
3. This sample tested is in compliance with the above regulation.
4. The test results in this report are traceable to the national or international standards.
- 5.

Date of test: January 19 to March 3, 2007

Tested by:

  
Kenichi Adachi  
EMC Services

  
Makoto Kosaka  
EMC Services

  
Motoya Imura  
EMC Services

Approved  
by :

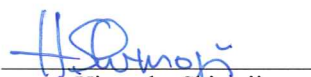
  
Hironobu Shimoji  
Assistant Manager of EMC  
Services



NVLAP LAB CODE: 200572-0

This laboratory is accredited by the NVLAP LAB CODE 200572-0, U.S.A. The tests reported herein have been performed in accordance with its terms of accreditation.  
\*As for the range of Accreditation in NVLAP, you may refer to the WEB address,  
<http://uljapan.co.jp/emc/nvlap.htm>

UL Japan, Inc.

Head Office EMC Lab.

4383-326 Asama-cho, Ise-shi, Mie-ken 516-0021 JAPAN

Telephone : +81 596 24 8116

Facsimile : +81 596 24 8124

MF060b (18.06.07)

<b>CONTENTS</b>	<b>PAGE</b>
SECTION 1: Client information .....	3
SECTION 2: Equipment under test (E.U.T.).....	3
SECTION 3: Test specification, procedures & results.....	5
SECTION 4: Operation of E.U.T. during testing.....	8
SECTION 5: Conducted Emission.....	11
SECTION 6: Spurious Emission .....	12
SECTION 7: Bandwidth.....	13
SECTION 8: Maximum Peak Output Power .....	13
SECTION 9: Peak Power Density.....	13
APPENDIX 1: Photographs of test setup .....	14
Conducted Emission .....	14
Spurious Emission (Radiated) .....	16
Worst Case Position (Horizontal: EUT-X-axis, Ant-X-axis/ Vertical:EUT-X-axis, Ant-Y-axis) .....	17
APPENDIX 2: Data of EMI test.....	21
Conducted Emission .....	21
6dB Bandwidth.....	37
Maximum Peak Output Power.....	40
Radiated Spurious Emission (below 1GHz) .....	42
Radiated Spurious Emission (above 1GHz) .....	54
Conducted Spurious Emission.....	74
Conducted emission Band Edge compliance.....	84
Power Density.....	85
99%Occupied Bandwidth .....	88
APPENDIX 3:Test instruments .....	90

## **SECTION 1: Client information**

Company Name : OMRON Corporation Okayama factory  
Address : 2075 Miyoshi Okayama-city, Okayama, 703-8502, Japan  
Telephone Number : +81-86-276-1797  
Facsimile Number : +81-86-276-1520  
Contact Person : Shinji Ueno

## **SECTION 2: Equipment under test (E.U.T.)**

### **2.1 Identification of E.U.T.**

Type of Equipment : FA Wireless LAN Unit  
Model No. : WE70-CL (applied model)  
WE70-AP (tested model)\*  
Serial No. : 279651000201 (for Radiated Emission and Conducted Emission tests)  
279651000202 (for Antenna Terminal Conducted test)  
Rating : DC 24V (20.4V to 26.4V)  
Country of Manufacture : JAPAN  
Receipt Date of Sample : January 19, 2007  
Condition of EUT : Production prototype  
(Not for Sale: This sample is equivalent to mass-produced items.)  
Modification of EUT : No modification by the test lab.

\*As WE70-CL is identical to WE70-AP in radio specification, the test data for WE70-AP is included in this test report and used for the application of WE70-CL.

### **2.2 Product Description**

Model No: WE70-CL is the, FA Wireless LAN Unit (Client).  
WE70-CL has a variant model: WE70-AP (Master). They are identical in radio specification  
The difference between two models is the presence or absence of RSSI button (for receiving status indication) only.  
(WE70-AP does not have the button, but WE70-CL does.)

Clock Frequencies are 20MHz(CPU Clock), 25MHz(LAN Clock), 80MHz(Memory Clock) and 40MHz (Wireless LAN).

---

## **UL Japan, Inc.**

### **Head Office EMC Lab.**

4383-326 Asama-cho, Ise-shi, Mie-ken 516-0021 JAPAN

Telephone : +81 596 24 8116

Facsimile : +81 596 24 8124

**IEEE802.11b / 11g / 11a WLAN**

Equipment Type	Transceiver		
Frequency of Operation	11b/11g	2412MHz - 2462MHz	
	11a	Low	5180MHz - 5240MHz *1)
		Mid	5260MHz - 5320MHz *1) *2)
		Add	5500MHz - 5700MHz *1) *2)
		Upper	5745MHz - 5805MHz *1) 5825MHz
Type of Modulation	DSSS, DBPSK, DQPSK, CCK (11b) OFDM, BPSK, QPSK, 16QAM, 64QAM, CCK (11g, 11a)		
Bandwidth	20MHz		
Channel spacing	5MHz (11b/11g), 20MHz (11a)		
Power Supply (inner)	DC 3.3V		
Antenna Connector Type	Reverse SMA connector (ANT A and ANT B)		
Antenna Information	Type	: Dual Band Diversity Antenna	
	Model name	: ANT-S-789	
	Gain	: 2.14dBi (max)	
	Type	: Magnetic Pedestal Antenna *3)	
	Model name	: WE70-AT001H(OMR04-220100)	
	Gain	: 2.4GHz band: 4.5dBi (max) 5GHz band: 7dBi (max)	
	Type	: Magnetic Pedestal Antenna with extension cable of 5.0m *4)	
	Model name	: WE70-AT001H (OMR04-220100)	
	Gain	: 2.4GHz band: 4.5dBi (max) 5GHz band: 7dBi (max)	

\*1) Refer to 27DE0139-HO-D FCC Part 15E (FCC 15.407) report.

\*2) Refer to 27DE0139-HO-F FCC Part 15E (FCC 15.407 DFS) report.

\*3) Magnetic Pedestal Antenna is connected directly with the cable of 2.0m.

\*4) Magnetic Pedestal Antenna can be used with extension cable of 5.0 m (Total length of cable: 7.0m).

**[Remarks]**

The circuits for 2.4GHz and 5GHz bands are included in one chip of FA Wireless LAN Unit.

**UL Japan, Inc.**

**Head Office EMC Lab.**

4383-326 Asama-cho, Ise-shi, Mie-ken 516-0021 JAPAN

Telephone : +81 596 24 8116

Facsimile : +81 596 24 8124

### **SECTION 3: Test specification, procedures & results**

#### **3.1 Test Specification**

Test Specification : FCC Part15 Subpart C: 2007  
Title : FCC 47CFR Part15 Radio Frequency Device Subpart C Intentional Radiators  
Section 15.207 Conducted limits  
Section 15.247 Operation within the bands 902-928MHz, 2400-2483.5MHz, and 5725-5850MHz

#### **FCC 15.31 (e)**

This EUT provides the stable voltage (DC3.3V) constantly to RF Module regardless of input voltage. Therefore, this EUT complies with the requirement.

#### **FCC Part 15.203 Antenna requirement**

This EUT complies with the requirement of 15.203, because a unique coupling (Antenna Connector Type: Reverse SMA) is used for this EUT.

---

**UL Japan, Inc.**

**Head Office EMC Lab.**

4383-326 Asama-cho, Ise-shi, Mie-ken 516-0021 JAPAN

Telephone : +81 596 24 8116

Facsimile : +81 596 24 8124

### 3.2 Procedures and results

No.	Item	Test Procedure	Specification	Remarks	Deviation	Worst margin	Results
1	Conducted emission	FCC: ANSI C63.4:2003 7. AC powerline conducted emission measurements ----- IC: RSS-Gen 7.2.2	FCC: Section 15.207 ----- IC: RSS-Gen 7.2.2	-	N/A	15.3dB, 4.99553MHz, QP, N	Complied
2	6dB Bandwidth	FCC: ANSI C63.4:2003 13. Measurement of intentional radiators ----- IC: RSS-Gen 4.4.2	FCC: Section 15.247(a)(2) ----- IC: RSS-210 A8.2(a)	Conducted	N/A	See data.	Complied
3	Maximum Peak Output Power	FCC: ANSI C63.4:2003 13. Measurement of intentional radiators ----- IC: RSS-Gen 4.6	FCC: Section 15.247(b)(3) ----- IC: RSS-210 A8.4(4)	Conducted	N/A		Complied
4	Restricted Band Edges	FCC: ANSI C63.4:2003 13. Measurement of intentional radiators ----- IC: -	FCC: Section 15.247 (d) ----- IC: RSS-210 A8.5	Conducted/ Radiated	N/A		Complied
5	Power Density	FCC: ANSI C63.4:2003 13. Measurement of intentional radiators ----- IC: -	FCC: Section 15.247 (e) ----- IC: RSS-210 A8.2(b)	Conducted	N/A		Complied
6	Spurious Emission	FCC: ANSI C63.4:2003 13. Measurement of intentional radiators ----- IC: RSS-Gen 4.7 RSS-Gen 4.8	FCC: Section 15.247(d) ----- IC: RSS-210 A8.5 RSS-Gen 7.2.1 and 7.2.3	Conducted/ Radiated	N/A		<Tx> 2.2dB, 88.000MHz, Vertical, QP <Rx> 2.7dB, 88.000MHz, Vertical, QP

Note: UL Japan's EMI Work Procedures No.QPM05 and QPM15.

\*These tests were also referred to "Guidance on Measurement of Digital Transmission Systems Operating under Section 15.247".

\*These tests were performed without any deviations from test procedure except for additions or exclusions.

### 3.3 Addition to standards

No.	Item	Test Procedure	Specification	Remarks	Deviation	Worst margin	Results
1	99% Occupied Band Width	RSS-Gen 4.4.1	RSS-Gen 4.4.1	Conducted	N/A	N/A	N/A

**UL Japan, Inc.**

**Head Office EMC Lab.**

4383-326 Asama-cho, Ise-shi, Mie-ken 516-0021 JAPAN

Telephone : +81 596 24 8116

Facsimile : +81 596 24 8124

### 3.4 Uncertainty

The following uncertainties have been calculated to provide a confidence level of 95% using a coverage factor k=2.

#### Conducted Emission

The measurement uncertainty for this test is  $\pm 2.66$ dB.

The data listed in this test report has enough margin, more than the site margin.

#### Spurious Emission (Radiated)

The measurement uncertainty for this test using Biconical antenna is  $\pm 4.59$ dB(3m).

The measurement uncertainty for this test using Logperiodic antenna is  $\pm 4.62$ dB(3m).

The measurement uncertainty for this test using Horn antenna is  $\pm 5.27$ dB.

The data listed in this report meets the limits unless the uncertainty is taken into consideration.

#### Other test except Conducted Emission and Spurious Emission (Radiated)

The measurement uncertainty for this test is  $\pm 3.0$ dB.

### 3.5 Test Location

UL Japan, Inc. Head Office EMC Lab. \*NVLAP Lab. code: 200572-0

4383-326 Asama-cho, Ise-shi, Mie-ken 516-0021 JAPAN

Telephone: +81 596 24 8116

Facsimile: +81 596 24 8124

	FCC Registration Number	IC Registration Number	Width x Depth x Height (m)	Size of reference ground plane (m) / horizontal conducting plane	Other rooms
No.1 semi-anechoic chamber	313583	IC4247A	19.2 x 11.2 x 7.7m	7.0 x 6.0m	Preparation room
No.2 semi-anechoic chamber	655103	IC4247A-2	7.5 x 5.8 x 5.2m	4.0 x 4.0m	-
No.3 semi-anechoic chamber	148738	IC4247A-3	12.0 x 8.5 x 5.9m	6.8 x 5.75m	
No.3 shielded room	-	-	4.0 x 6.0 x 2.7m	N/A	-
No.4 semi-anechoic chamber	134570	IC4247A-4	12.0 x 8.5 x 5.9m	6.8 x 5.75m	-
No.4 shielded room	-	-	4.0 x 6.0 x 2.7m	N/A	-
No.5 semi-anechoic chamber	-	-	6.0 x 6.0 x 3.9m	N/A	-
No.6 shielded room	-	-	4.0 x 4.5 x 2.7m	2.0 x 2.0 m	-
No.6 measurement room	-	-	4.75 x 5.4 x 3.0m	4.75 x 5.4 m	-
No.7 shielded room	-	-	4.7 x 7.5 x 2.7m	4.7 x 7.5m	-
No.8 measurement room	-	-	3.1 x 5.0 x 2.7m	N/A	-

\* Size of vertical conducting plane (for Conducted Emission test) : 2.0 x 2.0m for No.1, No.2, No.3 and No.4 semi-anechoic chambers and No.3 and No.4 shielded rooms.

Our company name was changed from "UL Apex Co., Ltd." To "UL Japan, Inc." on April 26, 2007.

### 3.6 Test set up, Test instruments and Data of EMI

Refer to APPENDIX 1 to 3.

## UL Japan, Inc.

### Head Office EMC Lab.

4383-326 Asama-cho, Ise-shi, Mie-ken 516-0021 JAPAN

Telephone : +81 596 24 8116

Facsimile : +81 596 24 8124

**SECTION 4: Operation of E.U.T. during testing**

**4.1 Operating Modes**

The mode is used :

The EUT was operating in a manner similar to typical use during the tests.

IEEE 802.11b: CCK (11Mbps(worst), Payload: PN9, High power) \* See Remarks.

- Transmitting mode
  - Low channel : 2412MHz
  - Middle channel : 2437MHz
  - High channel : 2462MHz
- Receiving mode
  - Mid channel : 2437MHz

IEEE 802.11g: OFDM(54Mbps(Worst), Payload: PN9, High power) \* See Remarks.

- Transmitting mode
  - Low channel : 2412MHz
  - Middle channel : 2437MHz
  - High channel : 2462MHz
- Receiving mode
  - Mid channel : 2437MHz

IEEE 802.11a: OFDM(54Mbps(Worst), Payload: PN9, High power) \* See Remarks.

- Transmitting mode : 5825MHz
- Receiving mode : 5825MHz

**Remarks**

- Conditions :
- 1) Data Rate:IEEE802.11g / 11a : 6M, 9M, 12M, 18M, 24M, 36M, 48M, 54 M bps  
IEEE802.11b: 1M, 2M, 5.5M, 11M bps
  - 2) Antenna Connector: ANT A, ANT B (same connector type)
  - 3) Antenna Type: Dual Band Diversity Antenna  
Magnetic Pedestal Antenna  
Magnetic Pedestal Antenna with extension cable of 5.0m
  - 4) High / Mid / Low power

As a result of the preliminary test, the final test was performed under the worst conditions of the above. See the below table for the details of the worst conditions.

**Worst Conditions:**

Test Item	IEEE802.11b	IEEE802.11g / 11a
All tests	1) Rate:11Mbps	1) Rate:54Mbps
	2) Antenna Port: ANT A	
	3) Dual Band Diversity Antenna	
	4) High power	

However, some test items were performed with other antennas in addition to the worst one (Dual Band Diversity Antenna). See the below table for the details.

Test Item	Tested Antenna type
Tx (11b / 11g) Middle Ch. Spurious emissions and Tx (11a) 5825MHz Spurious emissions tests.	Dual Band Diversity Antenna
	Magnetic Pedestal Antenna
Tx (11b / 11g) Low / High ch. BandEdge emissions tests.	Dual Band Diversity Antenna
	Magnetic Pedestal Antenna
	Magnetic Pedestal Antenna with extension cable of 5.0m

**UL Japan, Inc.**

**Head Office EMC Lab.**

4383-326 Asama-cho, Ise-shi, Mie-ken 516-0021 JAPAN

Telephone : +81 596 24 8116

Facsimile : +81 596 24 8124



4.2 Configuration and peripherals

4.2.1 Conducted emissions/Antenna Terminal Conducted test

(1) Dual Band Diversity Antenna

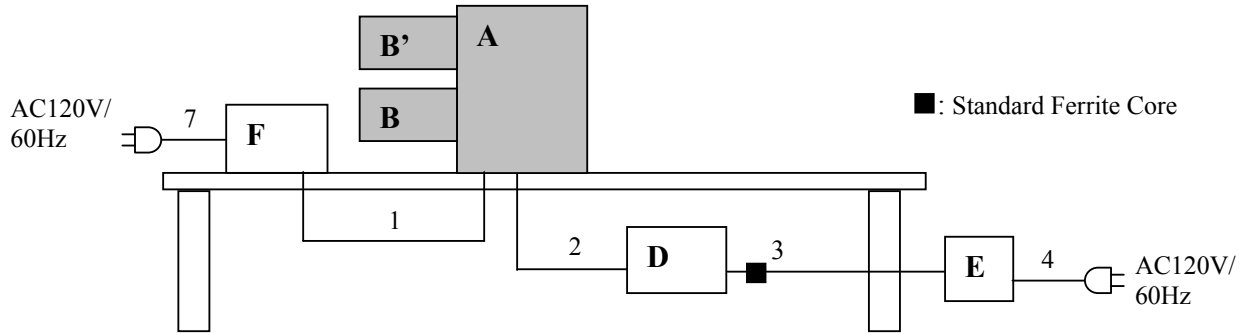

(2) Magnetic Pedestal Antenna

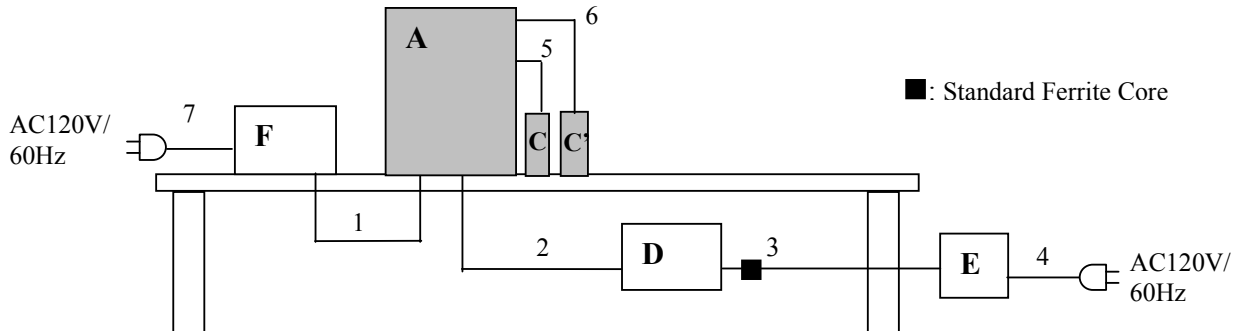

\* Cabling and setup were taken into consideration and test data was taken under worse case conditions.

4.2.2 Radiated emissions

(1) Dual Band Diversity Antenna

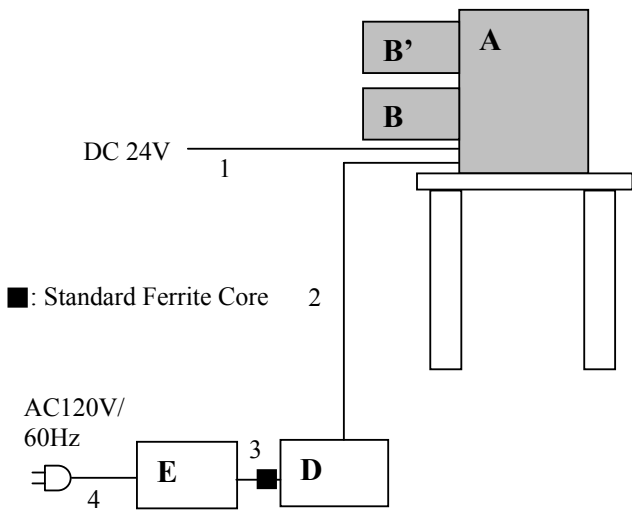

(2) Magnetic Pedestal Antenna

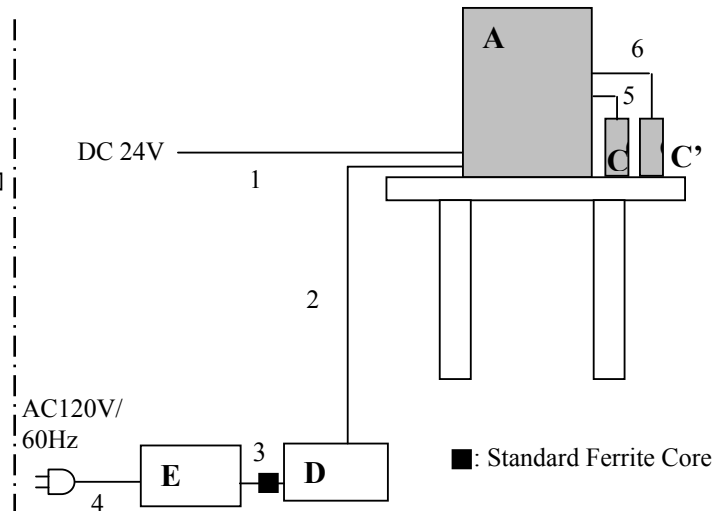

\* Cabling and setup were taken into consideration and test data was taken under worse case conditions.

UL Japan, Inc.

Head Office EMC Lab.

4383-326 Asama-cho, Ise-shi, Mie-ken 516-0021 JAPAN

Telephone : +81 596 24 8116

Facsimile : +81 596 24 8124

**Description of EUT and Support equipment**

No.	Item	Model number	Serial number	Manufacturer	Remark
A	FA Wireless LAN Unit	WE70-AP	279651000201 *1) 279651000202 *2)	OMRON	EUT
B,B'	Dual Band Diversity Antenna	-	-	OMRON	EUT
C,C'	Magnetic Pedestal Antenna	-	-	OMRON	EUT
D	Personal Computer	TYPE2366-LJ7	97-99D4L	IBM	-
E	AC Adapter	02K6750	11S02K6750Z1Z2UP29ADTJ	IBM	-
F	DC power supply	6654A	MY40000510	Agilent	-

\*1) for Conducted Emission and Radiated Emission tests.

\*2) for Antenna Terminal Conducted test

**List of cables used**

No.	Name	Length (m)	Shield	
			Cable	Connector
1	DC cable	2.5	Unshielded	Unshielded
2	LAN cable	3.0	Shielded	Shielded
3	DC cable	1.8	Unshielded	Unshielded
4	AC cable	1.0	Unshielded	Unshielded
5	Antenna cable	2.0, 7.0 *3)	Shielded	Shielded
6	Antenna cable	2.0, 7.0 *3)	Shielded	Shielded
7	AC cable	2.2	Unshielded	Unshielded

\*3) Without extension cable of 5.0m = 2.0m, With extension cable of 5.0m = 7.0m (2.0m + 5.0m.)

**UL Japan, Inc.**

**Head Office EMC Lab.**

4383-326 Asama-cho, Ise-shi, Mie-ken 516-0021 JAPAN

Telephone : +81 596 24 8116

Facsimile : +81 596 24 8124

## **SECTION 5: Conducted Emission**

### **Test Procedure and conditions**

EUT was placed on a urethane platform of nominal size, 1.5m by 1.0m, raised 80cm above the conducting ground plane. The rear of tabletop was located 40cm to the vertical conducting plane. The rear of EUT, including peripherals aligned and flushed with rear of tabletop. All other surfaces of tabletop were at least 80cm from any other grounded conducting surface. EUT was located 80cm from a Line Impedance Stabilization Network (LISN)/ Artificial mains Network (AMN) and excess AC cable was bundled in center.

#### For the tests on EUT with other peripherals (as a whole system)

I/O cable and AC cables that were connected to the peripherals were bundled in center. They were folded back and forth forming a bundle 30cm to 40cm long and were hanged at a 40cm height to the ground plane. All unused 50ohm connectors of the LISN(AMN) were resistivity terminated in 50ohm when not connected to the measuring equipment.

The AC Mains Terminal Continuous disturbance Voltage has been measured with the EUT in a Semi Anechoic Chamber or a Measurement Room.

The EUT was connected to a LISN (AMN).

An overview sweep with peak detection has been performed.

<b>Detector</b>	<b>: CISPR quasi-peak and average detector (IF BW 9 kHz)</b>
<b>Measurement range</b>	<b>: 0.15-30MHz</b>
<b>Test data</b>	<b>: APPENDIX 2</b>
<b>Test result</b>	<b>: Pass</b>

---

**UL Japan, Inc.**

**Head Office EMC Lab.**

4383-326 Asama-cho, Ise-shi, Mie-ken 516-0021 JAPAN

Telephone : +81 596 24 8116

Facsimile : +81 596 24 8124

**SECTION 6: Spurious Emission**

**[Conducted]**

**Test Procedure**

The Out of Band Emission was measured with a spectrum analyzer connected to the antenna port.

**Test data : APPENDIX 2**

**Test result : Pass**

**[Radiated]**

**Test Procedure**

EUT was placed on a urethane platform of nominal size, 0.5m by 1.0m, raised 80cm above the conducting ground plane. The Radiated Electric Field Strength intensity has been measured in a Semi Anechoic Chamber with a ground plane and at a distance of 3m(Below 10GHz) and 1m(Upper 10GHz).

The height of the measuring varied between 1 and 4m and EUT was rotated a full revolution in order to obtain the maximum value of the electric field intensity.

The measurements were performed for both vertical and horizontal antenna polarization with the Test Receiver, or the Spectrum Analyzer (in linear mode).

The test was made with the detector (RBW/VBW) in the following table.

When using Spectrum analyzer, the test was made with adjusting span to zero by using peak hold.

In any 100kHz bandwidth outside the frequency band in which the spread spectrum intentional radiator is operating, the radio frequency power that is produced by the intentional radiator confirmed 20dB below that in the 100kHz bandwidth within the band that contains the highest level of the desired power, based on a radiated measurement.

**20dBc was applied to the frequency over the limit of FCC 15.209 and outside the restricted band of FCC15.205.**

Frequency	Below 1GHz	Above 1GHz
Instrument used	Test Receiver / Spectrum Analyzer	Spectrum Analyzer
Detector	QP: BW 120kHz(T/R)	PK: RBW:1MHz/VBW: 1MHz
IF Bandwidth	20dBc : RBW: 100kHz VBW: 300kHz (S/A)	AV: RBW:1MHz/VBW:10Hz 20dBc : RBW:100kHz/VBW:300kHz

- The carrier level and noise levels were confirmed at each position of X, Y and Z axes of EUT and EUT's antenna to see the position of maximum noise, and the test was made at the position that has the maximum noise.

**Test data : APPENDIX 2**

**Test result : Pass**

---

**UL Japan, Inc.**

**Head Office EMC Lab.**

4383-326 Asama-cho, Ise-shi, Mie-ken 516-0021 JAPAN

Telephone : +81 596 24 8116

Facsimile : +81 596 24 8124

## **SECTION 7: Bandwidth**

### **Test Procedure**

The bandwidth was measured with a spectrum analyzer connected to the antenna port.

**Test data** : APPENDIX 2  
**Test result** : Pass

## **SECTION 8: Maximum Peak Output Power**

### **Test Procedure**

The Maximum Peak Output Power was measured with a power meter (tested bandwidth: 50MHz) connected to the antenna port.

It was measured based on "Power Output Option 1" of "Guidance on Measurement of Digital Transmission Systems Operating under Section15.247".

**Test data** : APPENDIX 2  
**Test result** : Pass

## **SECTION 9: Peak Power Density**

[Conducted]

### **Test Procedure**

The Peak Power Density was measured with a spectrum analyzer connected to the antenna port.

It was measured based on "PSD Option 1" of "Guidance on Measurement of Digital Transmission Systems Operating under Section15.247".

**Test data** : APPENDIX 2  
**Test result** : Pass

---

**UL Japan, Inc.**

**Head Office EMC Lab.**

4383-326 Asama-cho, Ise-shi, Mie-ken 516-0021 JAPAN

Telephone : +81 596 24 8116

Facsimile : +81 596 24 8124