

Prüfbericht-Nr.: <i>Test report no.:</i>	CN21YVQP(P15E-WiFi) 001	Auftrags-Nr.: <i>Order no.:</i>	238518387	Seite 1 von 44 Page 1 of 44
Kunden-Referenz-Nr.: <i>Client reference no.:</i>	N/A	Auftragsdatum: <i>Order date:</i>	2021-08-02	
Auftraggeber: <i>Client:</i>	Hon Hai Precision Industry Co., Ltd. No.151, Sec. 1, Nankan Rd., Lujhu Dist., Taoyuan City 33859, Taiwan (R.O.C.)			
Prüfgegenstand: <i>Test item:</i>	802.11a/b/g/n/ac WLAN 2T2R + BT v5.1 Combo Module			
Bezeichnung / Typ-Nr.: <i>Identification / Type no.:</i>	WBU063-VZ			
Auftrags-Inhalt: <i>Order content:</i>	FCC Part 15E Test report (WiFi 5GHz)			
Prüfgrundlage: <i>Test specification:</i>	FCC 47CFR Part 15: Subpart E Section 15.407			
Wareneingangsdatum: <i>Date of sample receipt:</i>	2021-08-03			
Prüfmuster-Nr.: <i>Test sample no.:</i>	A003103482-006 & -004 A003103482-001			
Prüfzeitraum: <i>Testing period:</i>	2021-08-11 - 2021-09-09			
Ort der Prüfung: <i>Place of testing:</i>	EMC/RF Taipei Testing Site			
Prüflaboratorium: <i>Testing laboratory:</i>	Taipei Testing Laboratories			
Prüfergebnis*: <i>Test result*:</i>	Pass			
überprüft von: <i>compiled by:</i>	genehmigt von: <i>authorized by:</i>			
Datum: <i>Date:</i> 2021-09-11	David Huang	Ausstellungsdatum: <i>Issue date:</i> 2021-09-11	Brenda Chen	
Stellung / Position:	Project Manager	Stellung / Position:	Senior Project Manager	
Sonstiges / Other:				
Zustand des Prüfgegenstandes bei Anlieferung: <i>Condition of the test item at delivery:</i>	Prüfmuster vollständig und unbeschädigt <i>Test item complete and undamaged</i>			
* Legende:	1 = sehr gut P(ass) = entspricht o.g. Prüfgrundlage(n)	2 = gut F(ail) = entspricht nicht o.g. Prüfgrundlage(n)	3 = befriedigend N/A = nicht anwendbar	4 = ausreichend N/T = nicht getestet
* Legend:	1 = very good P(ass) = passed a.m. test specification(s)	2 = good F(ail) = failed a.m. test specification(s)	3 = satisfactory N/A = not applicable	4 = sufficient N/T = not tested
<p>Dieser Prüfbericht bezieht sich nur auf das o.g. Prüfmuster und darf ohne Genehmigung der Prüfstelle nicht auszugsweise vervielfältigt werden. Dieser Bericht berechtigt nicht zur Verwendung eines Prüfzeichens. <i>This test report only relates to the a. m. test sample. Without permission of the test center this test report is not permitted to be duplicated in extracts. This test report does not entitle to carry any test mark.</i></p>				

TEST SUMMARY

Report Section	FCC Clause	Test Item	Result
5.1.1	15.407(a) & 15.203	Antenna Requirement	Pass
5.1.2	15.407(a)	Maximum Conducted Output Power	Pass
5.1.3	15.407(a)	26 dB Bandwidth	Pass
5.1.3	2.1049	99% Occupied Bandwidth	Pass
5.1.4	15.407(e)	6 dB Bandwidth (U-NII-3 Band only)	Pass
5.1.5	15.407(g)	Frequency Stability	Pass
5.1.6	15.407(a)	Power Spectral Density	Pass
5.1.7	15.407(b) & 15.205 & 15.209	Radiated Spurious Emissions and Band Edges	Pass
5.1.8	15.407(h) & KDB 905462 D02	Dynamic Frequency Selection	Pass
5.2.1	15.207	Mains Conducted Emission	Pass

Note: Determining compliance based on the results of the compliance measurement, not taking into account measurement instrumentation uncertainty.

Contents

HISTORY OF THIS TEST REPORT	5
1. GENERAL REMARKS	6
1.1 COMPLEMENTARY MATERIALS.....	6
1.2 DECISION RULE OF CONFORMITY	6
2. TEST SITES	7
2.1 TEST LABORATORY	7
2.2 TEST FACILITY.....	7
2.3 TRACEABILITY	8
2.4 CALIBRATION	8
2.5 MEASUREMENT UNCERTAINTY	8
3. GENERAL PRODUCT INFORMATION.....	9
3.1 PRODUCT FUNCTION AND INTENDED USE	9
3.2 SYSTEM DETAILS AND RATINGS.....	9
3.3 NOISE GENERATING AND NOISE SUPPRESSING PARTS	11
3.4 SUBMITTED DOCUMENTS.....	11
4. TEST SET-UP AND OPERATION MODES.....	12
4.1 PRINCIPLE OF CONFIGURATION SELECTION	12
4.2 CARRIER FREQUENCY AND CHANNEL.....	13
4.3 TEST OPERATION AND TEST SOFTWARE.....	14
4.4 SPECIAL ACCESSORIES AND AUXILIARY EQUIPMENT	16
4.5 TEST SETUP DIAGRAM	17
4.6 DUTY CYCLE OF TEST SIGNAL	18
5. TEST RESULTS	19
5.1 TRANSMITTER REQUIREMENT & TEST SUITES.....	19
5.1.1 <i>Antenna Requirement</i>	<i>19</i>
5.1.2 <i>Maximum Conducted Output Power</i>	<i>20</i>
5.1.3 <i>26 dB Bandwidth and 99% Occupied Bandwidth.....</i>	<i>24</i>
5.1.4 <i>6 dB Bandwidth (5725-5850MHz).....</i>	<i>25</i>
5.1.5 <i>Frequency Stability Measurement.....</i>	<i>26</i>
5.1.6 <i>Power Spectral Density.....</i>	<i>31</i>
5.1.7 <i>Radiated Spurious Emissions</i>	<i>33</i>
5.1.8 <i>Dynamic Frequency Selection</i>	<i>38</i>
5.2 MAINS EMISSION	43
5.2.1 <i>Mains Conducted Emission.....</i>	<i>43</i>

Prüfbericht - Nr.: CN21YVQP(P15E-WiFi) 001
Test Report No.

Seite 4 von 44
Page 4 of 44

APPENDIX A - TEST RESULT OF CONDUCTED

APPENDIX B - TEST RESULT OF RADIATED EMISSIONS & MAINS CONDUCTED EMISSION

APPENDIX SP - PHOTOGRAPHS OF TEST SETUP

APPENDIX EP - PHOTOGRAPHS OF EUT

Prüfbericht - Nr.: CN21YVQP(P15E-WiFi) 001
Test Report No.**Seite 5 von 44**
Page 5 of 44

HISTORY OF THIS TEST REPORT

Report No.	Description	Date Issued
CN21YVQP(P15E-WiFi) 001	Original Release	2021-09-11

1. General Remarks

1.1 Complementary Materials

All attachments are integral parts of this test report. This applies especially to the following appendix:

Appendix A - Test Result of Conducted

Appendix B - Test Result of Radiated Emissions & Mains Conducted Emission

Appendix SP - Photographs of Test Setup

Appendix EP - Photographs of EUT

Applied Standard and Test Levels

Radio
FCC 47CFR Part 15: Subpart E Section 15.407
FCC 47CFR Part 2: Subpart J Section 2.1049
ANSI C63.10:2013
KDB 789033 D02 General UNII Test Procedures New Rules v02r01
KDB 905462 D02 UNII DFS Compliance Procedures New Rules v02
KDB 662911 D01 Multiple Transmitter Output v02r01

1.2 Decision Rule of Conformity

The decision rule of conformity of this test report is following the requirements of the requested standard in the quotation, and agreed among testing laboratory and manufacturer (applicant) to exclude the consideration of Measurement Uncertainty, unless it is required by the specific standard.

2. Test Sites

2.1 Test Laboratory

Taipei Testing Laboratories

11F. No.758, Sec. 4, Bade Rd., Songshan Dist.
Taipei City 105
Taiwan (R.O.C.)

2.2 Test Facility

Taipei Testing Laboratories

No.458-18, Sec. 2, Fenliao Rd., Linkou Dist.,
New Taipei City 244
Taiwan (R.O.C.)
FCC Registration No.: 226631
ISED Registration No.: 25563

2.3 Traceability

All measurement equipment calibrations are traceable to NML(Taiwan)/NIST(USA) or where calibration is performed outside Taiwan, to equivalent nationally recognized standards organizations.

2.4 Calibration

Equipment requiring calibration is calibrated periodically in a suitably accredited Calibration Lab. Additionally all equipment is verified for proper performance on a regular basis using in house standards or comparisons.

2.5 Measurement Uncertainty

All measurement uncertainty values are shown with a coverage factor of $k=2$ to indicate a 95% level of confidence.

Emission Measurement Uncertainty

Parameter	Uncertainty
Radiated Emission (9 kHz ~ 30 MHz)	± 1.15 dB
Radiated Emission (30 MHz ~ 200 MHz)	± 1.30 dB
Radiated Emission (200 MHz ~ 1 GHz)	± 1.30 dB
Radiated Emission (1 GHz ~ 18 GHz)	± 1.54 dB
Radiated Emission (18 GHz ~ 40 GHz)	± 2.52 dB
Mains Conducted Emission	± 1.65 dB

3. General Product Information

3.1 Product Function and Intended Use

The EUT is a 802.11a/b/g/n/ac WLAN 2T2R + BT v5.1 Combo Module. It contains a WLAN compatible module enabling the user to communicate data through a Wireless interface.

For details refer to the User Guide, Data Sheet and Circuit Diagram.

3.2 System Details and Ratings

Basic Information of EUT

Item	EUT information
Kind of Equipment/Test Item	802.11a/b/g/n/ac WLAN 2T2R + BT v5.1 Combo Module
Type Identification	WBU063-VZ
FCC ID	RX3-WBU063VZ

Technical Specification of EUT

Item	EUT information
Operating Frequency	Band 1: 5180 MHz ~ 5240 MHz Band 2: 5260 MHz ~ 5320 MHz Band 3: 5500 MHz ~ 5720 MHz Band 4: 5745 MHz ~ 5825 MHz
Channel Number	Band 1: 4 for 802.11a, 802.11n HT20, 802.11ac VHT20 2 for 802.11n HT40, 802.11ac VHT40 1 for 802.11ac VHT80 Band 2: 4 for 802.11a, 802.11n HT20, 802.11ac VHT20 2 for 802.11n HT40, 802.11ac VHT40 1 for 802.11ac VHT80 Band 3: 12 for 802.11a, 802.11n HT20, 802.11ac VHT20 6 for 802.11n HT40, 802.11ac VHT40 3 for 802.11ac VHT80 Band 4: 5 for 802.11a, 802.11n HT20, 802.11ac VHT20 2 802.11n HT40, 802.11ac VHT40 1 for 802.11ac VHT80
Data Rate	802.11a: 54.0 / 48.0 / 36.0 / 24.0 / 18.0 / 12.0 / 9.0 / 6.0 Mbps 802.11n: up to MCS7 802.11ac: up to MCS9
Operation Voltage	5 Vdc
Modulation	OFDM (BPSK, QPSK, 16QAM, 64QAM, 256QAM)

Prüfbericht - Nr.: CN21YVQP(P15E-WiFi) 001

Test Report No.

Seite 10 von 44

Page 10 of 44

Item	EUT information
Maximum Output Power (mW)	5180 ~ 5240 MHz: 47.68 5260 ~ 5320 MHz: 47.93 5500 ~ 5720 MHz: 48.67 5745 ~ 5825 MHz: 47.97
Maximum EIRP (mW)	5260 ~ 5320 MHz: 110.15 5500 ~ 5720 MHz: 137.09
DFS Mode	Slave without radar detection
Antenna Information	Refer to 5.1.1
Accessory Device	Refer to 4.4

3.3 Noise Generating and Noise Suppressing Parts

Refer to the Circuit Diagram.

3.4 Submitted Documents

- Circuit Diagram
- Instruction Manual
- Rating Label
- Technical Description

4. Test Set-up and Operation Modes

4.1 Principle of Configuration Selection

The test modes were adapted accordingly in reference to the instructions for use.

During testing, Channel and Power Controlling Software provided by the customer was used to control the operating channel as well as the output power level. The RF output power selection is for the setting of RF output expected by the customer and is going to be fixed on the firmware of the final end product.

Table for Parameters of Test Software Setting

802.11a		802.11n HT20 / 802.11ac VHT20		802.11n HT40 / 802.11ac VHT40		802.11ac VHT80	
Channel	Power Setting	Channel	Power Setting	Channel	Power Setting	Channel	Power Setting
36	0C	36	10	38	13	42	11
40	0D	40	10	46	13	58	10
48	0C	48	0E	54	13	106	12
52	0B	52	0E	62	13	122	12
60	0B	60	0F	102	15	138	12
64	0B	64	0F	110	15	155	12
100	0D	100	10	134	15		
116	0D	116	10	142	15		
140	0D	140	10	151	15		
144	0C	144	10	159	15		
149	0D	149	10				
157	0C	157	10				
165	0C	165	0F				

4.2 Carrier Frequency and Channel

Band	Channel	Frequency (MHz)	802.11a 802.11n HT20 802.11ac VHT20	802.11n HT40 802.11ac VHT40	802.11ac VHT80
U-NII-1 (Band 1)	36	5180	V		
	38	5190		V	
	40	5200	V		
	42	5210			V
	44	5220	V		
	46	5230		V	
U-NII-2A (Band 2)	48	5240	V		
	52	5260	V		
	54	5270		V	
	56	5280	V		
	58	5290			V
	60	5300	V		
U-NII-2C (Band 3)	62	5310		V	
	64	5320	V		
	100	5500	V		
	102	5510		V	
	104	5520	V		
	106	5530			V
	108	5540	V		
	110	5550		V	
	112	5560	V		
	116	5580	V		
	118	5590		V	
	120	5600	V		
	122	5610			V
	124	5620	V		
126	5630		V		
Straddle Channel	128	5640	V		
	132	5660	V		
U-NII-3 (Band 4)	134	5670		V	
	136	5680	V		
	140	5700	V		
	138	5690			V
	142	5710		V	
	144	5720	V		
	149	5745	V		
	151	5755		V	
153	5765	V			
U-NII-3 (Band 4)	155	5775			V
	157	5785	V		
	159	5795		V	
	161	5805	V		
	165	5825	V		

4.3 Test Operation and Test Software

Setup for testing: Test samples are provided with an USB interface which makes it possible to control them through a test software installed on a notebook computer.

This software was running on the laptop computer connected to the EUT. It was used to enable the operation modes listed as below.

Test Software	QA-Tool
---------------	---------

The samples were used as follows:

A003103482-006 & -004

A003103482-001

Full test was applied on all test modes, but only worst case was shown.

The EUT incorporates a MIMO function. Physically, the EUT provides two completed transmitters and receivers.

Modulation Mode	Tx Function
802.11a	2TX (MIMO)
802.11n HT20	2TX (MIMO)
802.11n HT40	2TX (MIMO)
802.11ac VHT20	2TX (MIMO)
802.11ac VHT40	2TX (MIMO)
802.11ac VHT80	2TX (MIMO)

* The modulation and bandwidth are similar for 802.11n mode HT20/HT40 and 802.11ac mode VHT20/VHT40, therefore investigated worse case as representative mode in test report.

EUT Configure Mode	Applicable To				Description
	Antenna Port Conducted Measurement	Radiated Spurious Emissions above 1 GHz	Radiated Spurious Emissions below 1 GHz	Mains Conducted Emission	
-	√	√	√	√	-

Note:

1. The EUT had been pre-tested on the positioned of each 3 axis. The worst case was found when position on **Z-plane**.
2. "-" means no effect.

Antenna Port Conducted Measurement

- Pre-Scan full test was applied on all test modes, but only worst case was shown.
- Following channel(s) was (were) selected for the final test as listed below.

EUT Configure Mode	Mode	Frequency (MHz)	Available Channel	Tested Channel	Date Rate (Mbps)
-	802.11a	5180-5240	36 to 48	36, 40, 48	6.0
-		5260-5320	52 to 64	52, 60, 64	
-		5500-5720	100 to 144	100, 116, 140, 144	
-		5745-5825	149 to 165	149, 157, 165	
-	802.11n HT20	5180-5240	36 to 48	36, 40, 48	6.5
-		5260-5320	52 to 64	52, 60, 64	
-		5500-5720	100 to 144	100, 116, 140, 144	
-		5745-5825	149 to 165	149, 157, 165	
-	802.11n HT40	5180-5240	38 to 46	38, 46	MCS0
-		5260-5320	54 to 62	54, 62	
-		5500-5720	102 to 142	102, 110, 134, 142	
-		5745-5825	151 to 159	151, 159	
-	802.11ac VHT80	5180-5240	42	42	MCS0
-		5260-5320	58	58	
-		5500-5720	106 to 138	106, 122, 138	
-		5745-5825	155	155	

Radiated Spurious Emissions (Above 1 GHz)

- Pre-Scan full test was applied on all test modes, but only worst case was shown.
- Following channel(s) was (were) selected for the final test as listed below.

EUT Configure Mode	Mode	Frequency (MHz)	Available Channel	Tested Channel	Date Rate (Mbps)
-	802.11a	5180-5240	36 to 48	36, 40, 48	6.0
-		5260-5320	52 to 64	52, 60, 64	
-		5500-5720	100 to 144	100, 116, 140, 144	
-		5745-5825	149 to 165	149, 157, 165	
-	802.11n HT20	5180-5240	36 to 48	36, 40, 48	6.5
-		5260-5320	52 to 64	52, 60, 64	
-		5500-5720	100 to 144	100, 116, 140, 144	
-		5745-5825	149 to 165	149, 157, 165	
-	802.11n HT40	5180-5240	38 to 46	38, 46	MCS0
-		5260-5320	54 to 62	54, 62	
-		5500-5720	102 to 142	102, 110, 134, 142	
-		5745-5825	151 to 159	151, 159	
-	802.11ac VHT80	5180-5240	42	42	MCS0
-		5260-5320	58	58	
-		5500-5720	106 to 138	106, 122, 138	
-		5745-5825	155	155	

Radiated Spurious Emissions (Below 1 GHz)

- Pre-Scan full test was applied on all test modes, but only worst case was shown.
 Following channel(s) was (were) selected for the final test as listed below.

EUT Configure Mode	Mode	Frequency (MHz)	Available Channel	Tested Channel	Date Rate (Mbps)
-	802.11ac VHT80	5180-5240	42	42	MCS0
-	802.11ac VHT80	5260-5320	58	58	MCS0
-	802.11ac VHT80	5500-5720	106 to 138	106	MCS0
-	802.11a	5745-5825	149 to 165	165	6.0

Mains Conducted Emission Test

- Pre-Scan full test was applied on all test modes, but only worst case was shown.
 Following channel(s) was (were) selected for the final test as listed below.

EUT Configure Mode	Mode	Frequency (MHz)	Available Channel	Tested Channel	Date Rate (Mbps)
-	802.11ac VHT80	5180-5240	42	42	MCS0

Test Condition

Test Item	Ambient Temperature	Relative Humidity	Tested by
Conducted Measurement	23.7-24.1 °C	51.6-53 %	Nick Hsu
Radiated Spurious Emissions above 1 GHz	23.1-25.1 °C	50-60 %	Simon Tsai
Radiated Spurious Emissions below 1 GHz	23.1-25.1 °C	50-60 %	Simon Tsai
Mains Conducted Emission	21.9 °C	59 %	Simon Tsai

4.4 Special Accessories and Auxiliary Equipment

The product has been tested together with the following additional accessories:

Accessory of EUT

None

Support Unit

No.	Description	Brand	Model	S/N	Remark
Radiated Test					
1	USB Cable	Pro-best	MK-USBMF-3M	-	300 m shielded cable w/o core
2	Notebook	HP	15s-du0007TX	CND93662VF	-
Mains Conducted Test					
1	Adapter	HP	TPN-CA16	-	180 m non-shielded cable w/o core
2	Notebook	HP	15s-du0007TX	CND93662VF	-
3	USB Cable	Pro-best	MK-USBMF-0.5M	-	50 m shielded cable w/o core
Conducted Test					
-	Notebook	LENOVO	TP00094A	PF-1GT015	-

4.5 Test Setup Diagram

<Radiated Spurious Emissions mode>

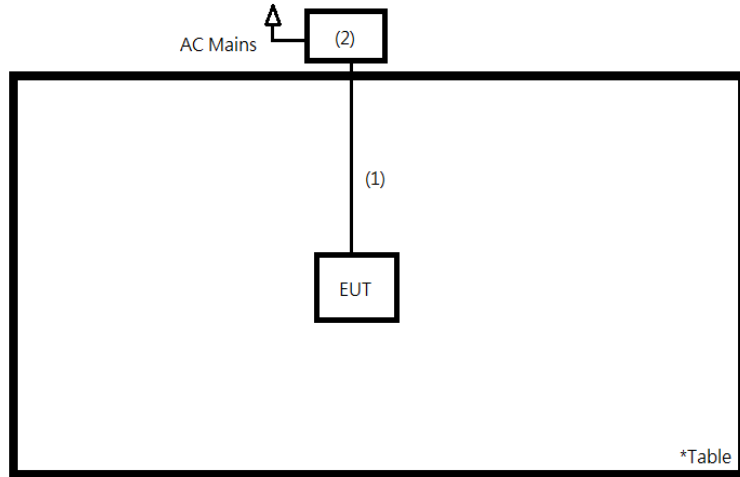

<Mains Conducted Emission mode>

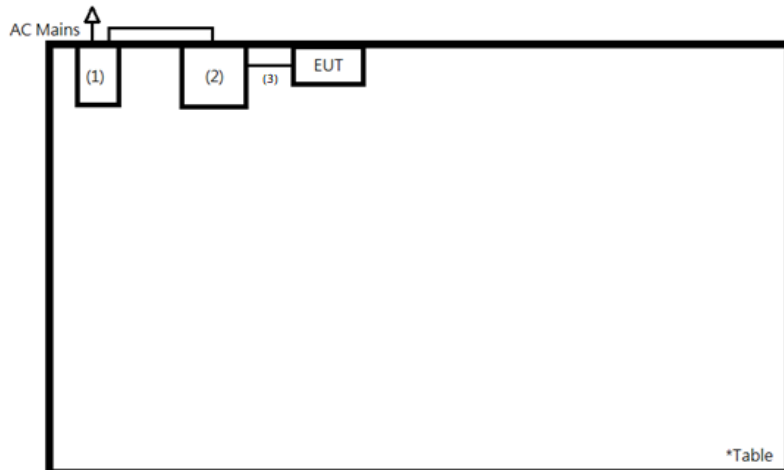

4.6 Duty Cycle of Test Signal

Mode	On + Off Time (ms)	On Time (ms)	Duty Cycle (%)	Duty Factor (dB)
802.11a	2.835	2.775	97.88	0.09
802.11n HT20	1.64	1.585	96.65	0.15
802.11n HT40	1.305	1.22	93.49	0.29
802.11ac VHT80	0.230	0.155	67.39	1.71

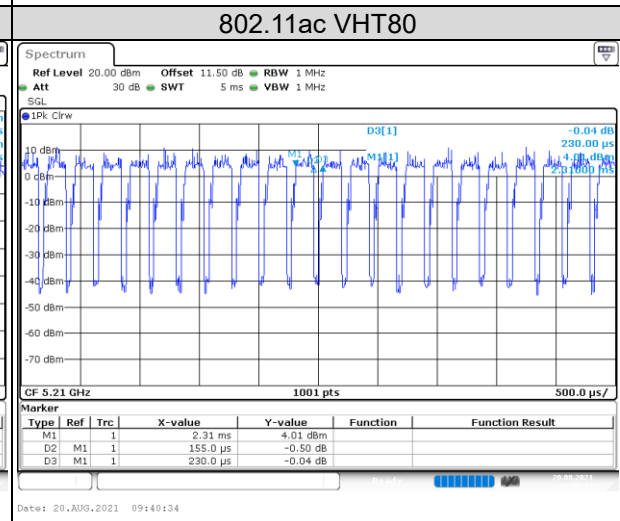
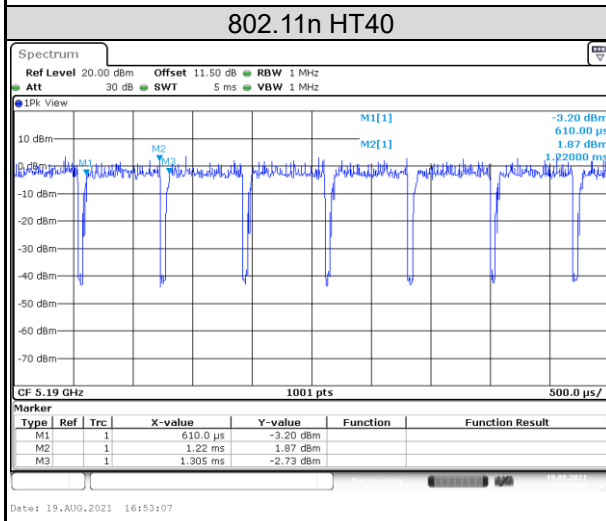
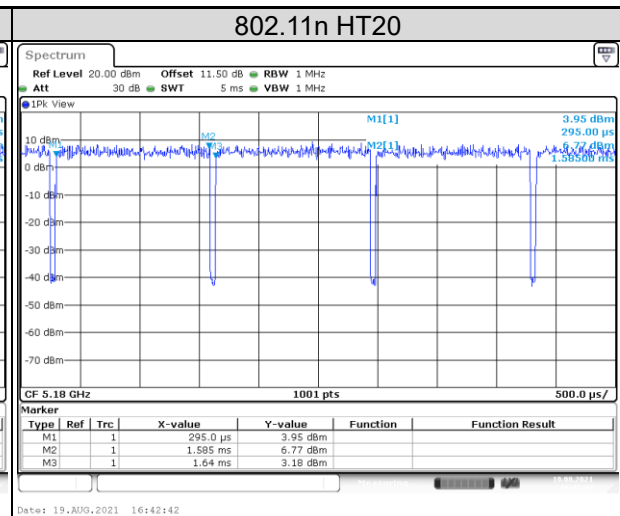
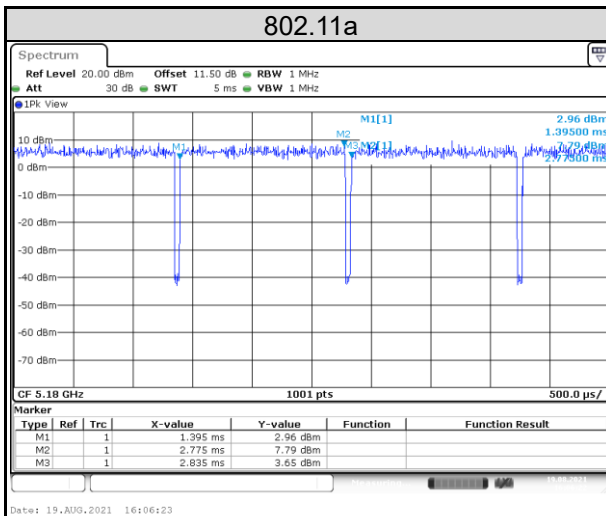

5. Test Results

5.1 Transmitter Requirement & Test Suites

5.1.1 Antenna Requirement

Requirement Use of approved antennas only

According to the manufacturer declaration, the EUT's antenna specifications are described as below. The antenna is used with no possibility of replacement with a non-approved antenna by the end-user. Therefore, the EUT is considered to comply with this provision.

ANT	Type	Frequency (MHz)			
		5180 ~ 5240	5260 ~ 5320	5500 ~ 5720	5745 ~ 5825
1	PCB	3.61 dBi	3.61 dBi	4.5 dBi	4.5 dBi
2	PCB	1.85 dBi	1.85 dBi	1.49 dBi	1.49 dBi
Directional Gain		5.78 dBi	5.78 dBi	6.14 dBi	6.14 dBi

Note: Directional gain = $10\log[(10^{G1/20} + 10^{G2/20} + \dots + 10^{GN/20})^2 / N_{ANT}]$

Refer to EUT photo for details.

5.1.2 Maximum Conducted Output Power

Limit

Operation Band	EUT Category	Limit
U-NII-1	Outdoor Access Point	1 Watt (30 dBm) (Max. e.i.r.p \leq 125 mW (21 dBm) at any elevation angle above 30 degrees as measured from the horizon)
	Fixed point-to-point Access Point	1 Watt (30 dBm)
	Indoor Access Point	1 Watt (30 dBm)
	Mobile and Portable client device	250 mW (24 dBm)
U-NII-2A	---	250 mW (24 dBm) or 11 dBm + 10 log B*
U-NII-2C	---	250 mW (24 dBm) or 11 dBm + 10 log B*
U-NII-3	---	1 Watt (30 dBm)

Note: B* is the 26 dB emission bandwidth in megahertz

Per KDB 662911 Method of conducted output power measurement on IEEE 802.11 devices,

Array Gain = 0 dB (i.e., no array gain) for $N_{ANT} \leq 4$;

Array Gain = 0 dB (i.e., no array gain) for channel widths ≥ 40 MHz for any N_{ANT} ;

Array Gain = 5 log(N_{ANT}/N_{SS}) dB or 3 dB, whichever is less for 20 MHz channel widths with $N_{ANT} \geq 5$.

For power measurements on all other devices: Array Gain = 10 log(N_{ANT}/N_{SS}) dB.

Kind of Test Site Shielded room

Test Setup

<802.11a, 802.11n HT20, 802.11n HT40>

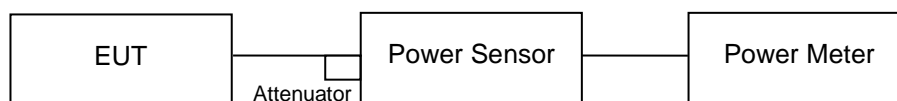

<802.11ac VHT80>

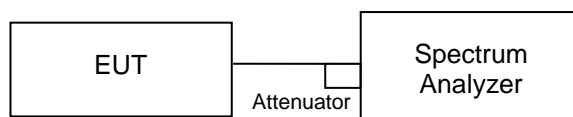

Test Instruments

Kind of Equipment	Manufacturer	Type	S/N	Calibration Date	Calibration Due Date	Test Date	
						From	Until
Power Meter	Anritsu	ML2495A	1901008	2021/3/24	2022/3/23	2021/8/11	2021/9/9
Power Sensor	Anritsu	MA2411B	1725269	2021/3/24	2022/3/23	2021/8/11	2021/9/9
Spectrum Analyzer	R&S	FSV40	101512	2021/1/29	2022/1/28	2021/8/11	2021/9/9

Test Procedures

<802.11a, 802.11n HT20, 802.11n HT40>

Method PM is used to perform output power measurement, trigger and gating function of wide band power meter is enabled to measure max output power of TX on burst and set the detector to AVERAGE. Duty factor is not added to measured value.

<802.11ac VHT80>

- a. Set span to encompass the entire 26 dB EBW (or, alternatively, the entire 99 % occupied bandwidth) of the signal.
- b. Set sweep trigger to "free run".
- c. Set RBW = 1 MHz.
- d. Set VBW \geq 3 MHz
- e. Number of points in sweep \geq 2 Span / RBW.
- f. Sweep time \leq (number of points in sweep) * T
- g. Using emission bandwidth to determine the frequency span for integration the channel bandwidth.
- h. Detector = RMS.
- i. Trace mode = max hold.
- j. Allow max hold to run for at least 60 seconds, or longer as needed to allow the trace to stabilize.

Test Result
<802.11a>

Channel	Channel Frequency (MHz)	Average Output Power (dBm)		Total Power		Limit (dBm)
		Chain 0	Chain 1	(dBm)	(mW)	
36	5180	10.77	10.06	13.44	22.08	24.00
40	5200	11.07	10.63	13.87	24.35	24.00
48	5240	11.24	10.59	13.94	24.76	24.00
52	5260	10.73	10.88	13.82	24.08	23.96
60	5300	10.76	10.41	13.60	22.90	23.99
64	5320	10.51	10.86	13.70	23.44	23.95
100	5500	11.02	10.70	13.87	24.40	23.99
116	5580	11.01	10.62	13.83	24.15	23.98
140	5700	11.09	10.68	13.90	24.55	23.96
144	5720	10.65	10.18	13.43	22.04	22.75
149	5745	11.25	10.70	13.99	25.08	30.00
157	5785	10.82	10.32	13.59	22.84	30.00
165	5825	11.31	10.53	13.95	24.82	30.00

Note:
For U-NII-2A, U-NII-2C Band:

1. $11 \text{ dBm} + 10\log(19.78) = 23.96 \text{ dBm} < 24 \text{ dBm}$.
2. $11 \text{ dBm} + 10\log(19.90) = 23.99 \text{ dBm} < 24 \text{ dBm}$.
3. $11 \text{ dBm} + 10\log(19.74) = 23.95 \text{ dBm} < 24 \text{ dBm}$.
4. $11 \text{ dBm} + 10\log(19.90) = 23.99 \text{ dBm} < 24 \text{ dBm}$.
5. $11 \text{ dBm} + 10\log(19.86) = 23.98 \text{ dBm} < 24 \text{ dBm}$.
6. $11 \text{ dBm} + 10\log(19.78) = 23.96 \text{ dBm} < 24 \text{ dBm}$.
7. $11 \text{ dBm} + 10\log(14.95) = 22.75 \text{ dBm} < 24 \text{ dBm}$.

<802.11n HT20>

Channel	Channel Frequency (MHz)	Average Output Power (dBm)		Total Power		Limit (dBm)
		Chain 0	Chain 1	(dBm)	(mW)	
36	5180	11.52	10.91	14.24	26.52	24.00
40	5200	11.47	10.88	14.20	26.27	24.00
48	5240	11.07	10.45	13.78	23.89	24.00
52	5260	11.13	11.25	14.20	26.31	24.00
60	5300	11.52	11.27	14.41	27.59	24.00
64	5320	11.62	11.35	14.50	28.17	24.00
100	5500	11.37	11.24	14.32	27.01	24.00
116	5580	11.38	10.91	14.16	26.07	24.00
140	5700	11.51	10.90	14.23	26.46	24.00
144	5720	11.47	10.94	14.22	26.44	22.80
149	5745	11.53	11.03	14.30	26.90	30.00
157	5785	11.58	11.12	14.37	27.33	30.00
165	5825	11.61	10.69	14.18	26.21	30.00

Note:
For U-NII-2A, U-NII-2C Band:

1. $11 \text{ dBm} + 10\log(20.22) = 24.06 \text{ dBm} > 24 \text{ dBm}$.
2. $11 \text{ dBm} + 10\log(20.14) = 24.04 \text{ dBm} > 24 \text{ dBm}$.
3. $11 \text{ dBm} + 10\log(20.18) = 24.05 \text{ dBm} > 24 \text{ dBm}$.
4. $11 \text{ dBm} + 10\log(20.26) = 24.07 \text{ dBm} > 24 \text{ dBm}$.
5. $11 \text{ dBm} + 10\log(20.10) = 24.03 \text{ dBm} > 24 \text{ dBm}$.
6. $11 \text{ dBm} + 10\log(20.14) = 24.04 \text{ dBm} > 24 \text{ dBm}$.
7. $11 \text{ dBm} + 10\log(15.15) = 22.80 \text{ dBm} < 24 \text{ dBm}$.

<802.11n HT40>

Channel	Channel Frequency (MHz)	Average Output Power (dBm)		Total Power		Limit (dBm)
		Chain 0	Chain 1	(dBm)	(mW)	
38	5190	13.02	12.45	15.75	37.62	24.00
46	5230	14.10	13.42	16.78	47.68	24.00
54	5270	13.70	13.89	16.81	47.93	24.00
62	5310	13.27	12.97	16.13	41.05	24.00
102	5510	13.91	13.75	16.84	48.32	24.00
110	5550	14.00	13.72	16.87	48.67	24.00
134	5670	13.99	13.50	16.76	47.45	24.00
142	5710	13.90	13.47	16.70	46.78	24.00
151	5755	13.99	13.60	16.81	47.97	30.00
159	5795	13.95	13.61	16.79	47.79	30.00

Note:
For U-NII-2A, U-NII-2C Band:

1. $11 \text{ dBm} + 10\log(41.72) = 27.20 \text{ dBm} > 24 \text{ dBm}$.
2. $11 \text{ dBm} + 10\log(41.48) = 27.18 \text{ dBm} > 24 \text{ dBm}$.
3. $11 \text{ dBm} + 10\log(41.48) = 27.18 \text{ dBm} > 24 \text{ dBm}$.
4. $11 \text{ dBm} + 10\log(41.32) = 27.16 \text{ dBm} > 24 \text{ dBm}$.
5. $11 \text{ dBm} + 10\log(41.48) = 27.18 \text{ dBm} > 24 \text{ dBm}$.
6. $11 \text{ dBm} + 10\log(35.86) = 26.55 \text{ dBm} > 24 \text{ dBm}$.

<802.11ac VHT80>

Channel	Channel Frequency (MHz)	Average Output Power (dBm)		Total Power		Limit (dBm)
		Chain 0	Chain 1	(dBm)	(mW)	
42	5210	12.04	11.41	14.75	29.83	24.00
58	5290	11.68	12.05	14.88	30.76	24.00
106	5530	12.01	11.83	14.93	31.13	24.00
122	5610	12.04	11.74	14.90	30.92	24.00
138	5690	12.02	11.61	14.83	30.41	24.00
155	5775	12.08	11.82	14.96	31.35	30.00

Note:
For U-NII-2A, U-NII-2C Band:

1. $11 \text{ dBm} + 10\log(80.88) = 30.08 \text{ dBm} > 24 \text{ dBm}$.
2. $11 \text{ dBm} + 10\log(80.72) = 30.07 \text{ dBm} > 24 \text{ dBm}$.
3. $11 \text{ dBm} + 10\log(81.04) = 30.09 \text{ dBm} > 24 \text{ dBm}$.
4. $11 \text{ dBm} + 10\log(75.60) = 29.79 \text{ dBm} > 24 \text{ dBm}$.

5.1.3 26 dB Bandwidth and 99% Occupied Bandwidth

Kind of Test Site Shielded room

Test Setup

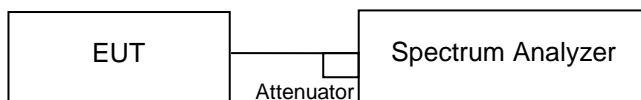

Test Instruments

Kind of Equipment	Manufacturer	Type	S/N	Calibration Date	Calibration Due Date	Test Date	
						From	Until
Spectrum Analyzer	R&S	FSV40	101512	2021/1/29	2022/1/28	2021/8/11	2021/9/9

Test Procedure

- a. Set RBW = approximately 1% of the emission bandwidth.
- b. Set the VBW > RBW.
- c. Detector = Peak.
- d. Trace mode = max hold.
- e. Measure the maximum width of the emission that is 26 dB down from the peak of the emission. Compare this with the RBW setting of the analyzer. Readjust RBW and repeat measurement as needed until the RBW/EBW ratio is approximately 1%.
- f. For 99% Bandwidth Measurement, the transmitter output was connected to the spectrum analyzer through an attenuator. The bandwidth of the fundamental frequency was measured by spectrum analyzer with resolution bandwidth in the range of 1% to 5% of the anticipated emission bandwidth, and a video bandwidth at least 3x the resolution bandwidth and set the detector to PEAK. The width of a frequency band such that, below the lower and above the upper frequency limits, the mean powers emitted are each equal to a specified percentage 0.5% of the total mean power of a given emission.

Test Results

Please refer to Appendix A

5.1.4 6 dB Bandwidth (5725-5850MHz)

Kind of Test Site Shielded room

Test Setup

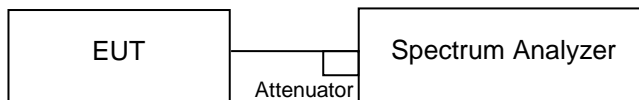

Test Instruments

Kind of Equipment	Manufacturer	Type	S/N	Calibration Date	Calibration Due Date	Test Date	
						From	Until
Spectrum Analyzer	R&S	FSV40	101512	2021/1/29	2022/1/28	2021/8/11	2021/9/9

Test Procedure

MEASUREMENT PROCEDURE REF

- a. Set resolution bandwidth (RBW) = 100 kHz
- b. Set the video bandwidth (VBW) $\geq 3 \times$ RBW, Detector = Peak.
- c. Trace mode = max hold.
- d. Sweep = auto couple.
- e. Measure the maximum width of the emission that is constrained by the frequencies associated with the two amplitude points (upper and lower) that are attenuated by 6 dB relative to the maximum level measured in the fundamental emission.

Test Results

Please refer to Appendix A

5.1.5 Frequency Stability Measurement

Kind of Test Site Shielded room

Test Setup

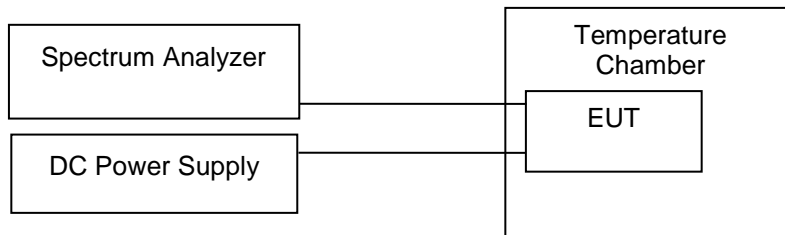

Test Instruments

Kind of Equipment	Manufacturer	Type	S/N	Calibration Date	Calibration Due Date	Test Date	
						From	Until
Spectrum Analyzer	R&S	FSV40	101512	2021/1/29	2022/1/28	2021/8/11	2021/9/9

Test Procedure

- a. To ensure emission at the band edge is maintained within the authorized band, those values shall be measured by radiation emissions at upper and lower frequency points, and finally compensated by frequency deviation as procedures below.
- b. The EUT was operated at the maximum output power, and connected to the spectrum analyzer, which is set to maximum hold function and peak detector. The peak value of the power envelope was measured and noted. The upper and lower frequency points were respectively measured relatively 10 dB lower than the measured peak value.
- c. The frequency deviation was calculated by adding the upper frequency point and the lower frequency point divided by two. Those detailed values of frequency deviation are provided in table below.

Test Results
<ANT0>

Frequency (MHz)	5200			
Voltage (V)	Measurement Frequency (MHz)			Max. Deviation (ppm)
5.5	5199.95022			9.573
5	5199.95051			9.517
4.5	5199.95022			9.573
Temperature (°C)	Measurement Frequency (MHz)			
	0 Minute	2 Minute	5 Minute	10 Minute
50	5199.94153	5199.94269	5199.94096	5199.94269
40	5199.93748	5199.93748	5199.93748	5199.93748
30	5199.94124	5199.94067	5199.94182	5199.94067
20	5199.95051	5199.95022	5199.95051	5199.95051
10	5199.96845	5199.96816	5199.96787	5199.96787
0	5199.99016	5199.99103	5199.99016	5199.99074
-10	5200.01331	5200.01302	5200.01302	5200.01274
-20	5200.00347	5200.00318	5200.00232	5200.0026
Max. Deviation (ppm)	12.023	12.023	12.023	12.023

Frequency (MHz)	5300			
Voltage (V)	Measurement Frequency (MHz)			Max. Deviation (ppm)
5.5	5299.94906			9.611
5	5299.94906			9.611
4.5	5299.94906			9.611
Temperature (°C)	Measurement Frequency (MHz)			
	0 Minute	2 Minute	5 Minute	10 Minute
50	5299.94327	5299.94327	5299.94298	5299.94356
40	5299.94719	5299.93632	5299.93632	5299.93632
30	5299.94038	5299.94009	5299.94038	5299.94038
20	5299.94906	5299.94906	5299.94906	5299.94906
10	5299.97279	5299.96729	5299.967	5299.96729
0	5299.98987	5299.98987	5299.98987	5299.98987
-10	5300.01823	5300.01302	5300.01389	5300.01274
-20	5300.00087	5300.00289	5300.00318	5300.00289
Max. Deviation (ppm)	11.249	12.015	12.015	12.015

Frequency (MHz)	5580			
Voltage (V)	Measurement Frequency (MHz)			Max. Deviation (ppm)
5.5	5579.94559			9.751
5	5579.95022			8.921
4.5	5579.94588			9.699
Temperature (°C)	Measurement Frequency (MHz)			
	0 Minute	2 Minute	5 Minute	10 Minute
50	5579.9369	5579.9398	5579.94038	5579.94038
40	5579.93285	5579.93285	5579.93285	5579.93285
30	5579.94182	5579.93719	5579.9369	5579.93661
20	5579.95022	5579.94616	5579.94588	5579.94588
10	5579.96324	5579.96382	5579.96382	5579.96382
0	5579.99653	5579.989	5579.98813	5579.98813
-10	5580.03531	5580.01708	5580.01245	5580.0136
-20	5580.02373	5579.99653	5579.99566	5579.99566
Max. Deviation (ppm)	12.913	12.913	12.913	12.913

Frequency (MHz)	5785			
Voltage (V)	Measurement Frequency (MHz)			Max. Deviation (ppm)
5.5	5784.94501			9.506
5	5784.9453			9.455
4.5	5784.94501			9.506
Temperature (°C)	Measurement Frequency (MHz)			
	0 Minute	2 Minute	5 Minute	10 Minute
50	5784.93835	5784.93835	5784.93835	5784.93835
40	5784.93025	5784.93025	5784.93025	5784.93025
30	5784.9343	5784.93459	5784.9343	5784.9343
20	5784.9453	5784.94501	5784.94501	5784.94501
10	5784.96324	5784.9644	5784.96382	5784.96411
0	5784.98871	5784.98813	5784.98842	5784.98842
-10	5784.97366	5784.97569	5784.97771	5784.97569
-20	5785.00376	5785.00145	5785.00058	5785.00116
Max. Deviation (ppm)	13.160	13.160	13.160	13.160

<ANT1>

Frequency (MHz)	5200			
Voltage (V)	Measurement Frequency (MHz)			Max. Deviation (ppm)
5.5	5199.95022			9.573
5	5199.95022			9.573
4.5	5199.95022			9.573
Temperature (°C)	Measurement Frequency (MHz)			
	0 Minute	2 Minute	5 Minute	10 Minute
50	5199.9424	5199.94153	5199.9424	5199.94182
40	5199.93777	5199.93748	5199.93748	5199.93748
30	5199.94067	5199.94124	5199.94124	5199.94124
20	5199.95022	5199.95051	5199.95051	5199.95022
10	5199.97569	5199.96903	5199.96845	5199.96845
0	5199.99103	5199.99074	5199.99045	5199.99074
-10	5200.01881	5200.01331	5200.01302	5200.01331
-20	5200.00232	5200.00058	5200.00058	5200
Max. Deviation (ppm)	11.967	12.023	12.023	12.023

Frequency (MHz)	5300			
Voltage (V)	Measurement Frequency (MHz)			Max. Deviation (ppm)
5.5	5299.94906			9.611
5	5299.9534			8.792
4.5	5299.94935			9.557
Temperature (°C)	Measurement Frequency (MHz)			
	0 Minute	2 Minute	5 Minute	10 Minute
50	5299.93922	5299.94269	5299.94327	5299.94327
40	5299.93632	5299.93632	5299.93632	5299.93632
30	5299.94385	5299.94067	5299.94009	5299.94038
20	5299.9534	5299.94935	5299.94906	5299.94935
10	5299.967	5299.96729	5299.96729	5299.967
0	5299.99537	5299.99045	5299.99016	5299.98987
-10	5300.01274	5300.01331	5300.01245	5300.01274
-20	5300.00666	5300.00058	5300	5300
Max. Deviation (ppm)	12.015	12.015	12.015	12.015

Frequency (MHz)	5580			
Voltage (V)	Measurement Frequency (MHz)			Max. Deviation (ppm)
5.5	5579.94559			9.751
5	5579.94559			9.751
4.5	5579.94559			9.751
Temperature (°C)	Measurement Frequency (MHz)			
	0 Minute	2 Minute	5 Minute	10 Minute
50	5579.94038	5579.94038	5579.94038	5579.94067
40	5579.93372	5579.93256	5579.93256	5579.93285
30	5579.93661	5579.93661	5579.93661	5579.93661
20	5579.94559	5579.94559	5579.94559	5579.94559
10	5579.97395	5579.96411	5579.96324	5579.96295
0	5579.98813	5579.98755	5579.98755	5579.98784
-10	5579.99566	5579.97019	5579.96845	5579.96932
-20	5579.99537	5579.99566	5579.99537	5579.99479
Max. Deviation (ppm)	12.746	12.969	12.969	12.913

Frequency (MHz)	5785			
Voltage (V)	Measurement Frequency (MHz)			Max. Deviation (ppm)
5.5	5784.9453			9.455
5	5784.94819			8.956
4.5	5784.9453			9.455
Temperature (°C)	Measurement Frequency (MHz)			
	0 Minute	2 Minute	5 Minute	10 Minute
50	5784.93546	5784.93806	5784.93835	5784.93835
40	5784.93025	5784.93025	5784.93025	5784.93025
30	5784.93777	5784.93459	5784.9343	5784.9343
20	5784.94819	5784.94443	5784.94414	5784.9453
10	5784.9644	5784.96382	5784.96411	5784.96411
0	5784.99595	5784.98929	5784.98871	5784.98871
-10	5784.98061	5784.98003	5784.98032	5784.98061
-20	5785.0081	5785.00579	5785.00521	5785.00521
Max. Deviation (ppm)	13.160	13.160	13.160	13.160

5.1.6 Power Spectral Density

Limit

For the 5.15~5.25GHz Bands:

For mobile and portable client devices in the 5.15~5.25GHz band, the Maximum Power spectral density shall not exceed 11dBm/MHz. For an indoor access point operating in the band 5.15~5.25GHz, the maximum power spectral density shall not exceed 17dBm/MHz.

For the 5.25~5.35GHz and 5.47~5.725GHz Bands:

The maximum power spectral density shall not exceed 11dBm/MHz.

For the 5.745~5.85GHz Bands:

The maximum power spectral density shall not exceed 30dBm/500kHz.

Kind of Test Site Shielded room

Test Setup

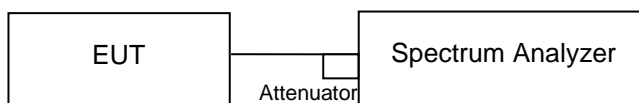

Test Instruments

Kind of Equipment	Manufacturer	Type	S/N	Calibration Date	Calibration Due Date	Test Date	
						From	Until
Spectrum Analyzer	R&S	FSV40	101512	2021/1/29	2022/1/28	2021/8/11	2021/9/9

Test Procedure**For U-NII-1, U-NII-2A, U-NII-2C band:**

Using method SA-2

1. Set span to encompass the entire emission bandwidth (EBW) of the signal.
2. Set RBW = 1 MHz, Set VBW \geq 3 MHz, Detector = RMS
3. Sweep time = auto, trigger set to "free run".
4. Trace average at least 100 traces in power averaging mode.
5. Record the max value and add 10 log (1/duty cycle)

※For U-NII-3:

1. Set span to encompass the entire emission bandwidth (EBW) of the signal.
2. Set RBW = 500 kHz, Set VBW \geq 3 RBW, Detector = RMS
3. Use the peak marker function to determine the maximum power level in any 500 kHz band segment within the fundamental EBW.
4. Sweep time = auto, trigger set to "free run".
5. Trace average at least 100 traces in power averaging mode.
6. Record the max value and add 10 log (1/duty cycle)

For MIMO mode, calculation method follows FCC KDB 662911 Method 2) a) of power density measurement using for calculating total power density. Total power density is summing entire spectra across corresponding frequency bins on the various outputs by computer.

Test Results

Please refer to Appendix A

5.1.7 Radiated Spurious Emissions

Limit

Radiated emissions which fall in the restricted bands, as defined in §15.205(a), must comply with the radiated emission limits specified in §15.209(a).

Emissions radiated outside the restricted and authorized frequency bands must either comply with the radiated emission limits specified for the restricted bands or in §15.407(b).

Kind of Test Site 3m Semi-Anechoic Chamber

Test Setup

<Radiated Emissions below 30 MHz>

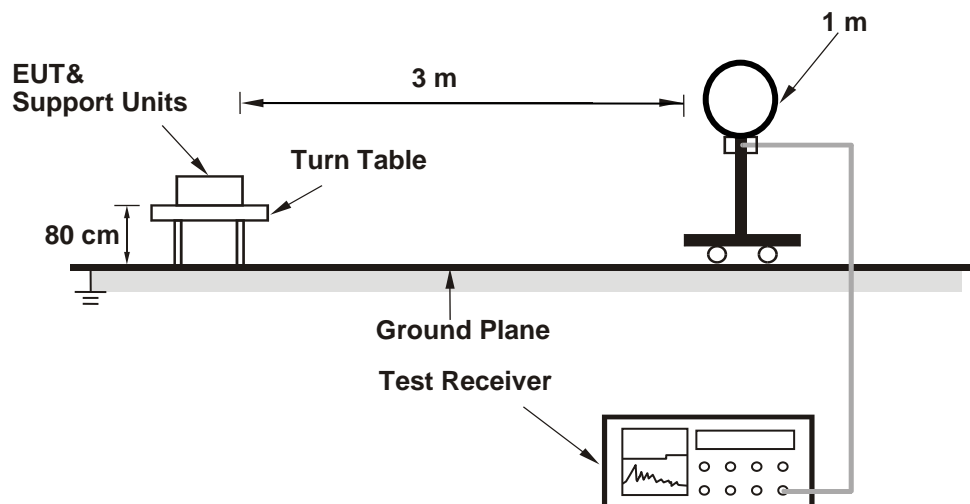

<Radiated Emissions 30 MHz to 1 GHz>

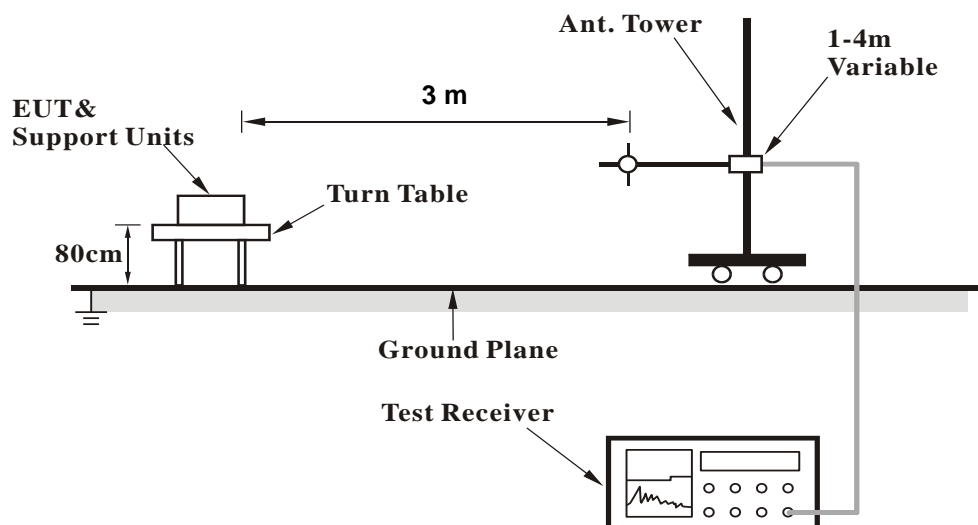

<Radiated Emissions above 1 GHz>

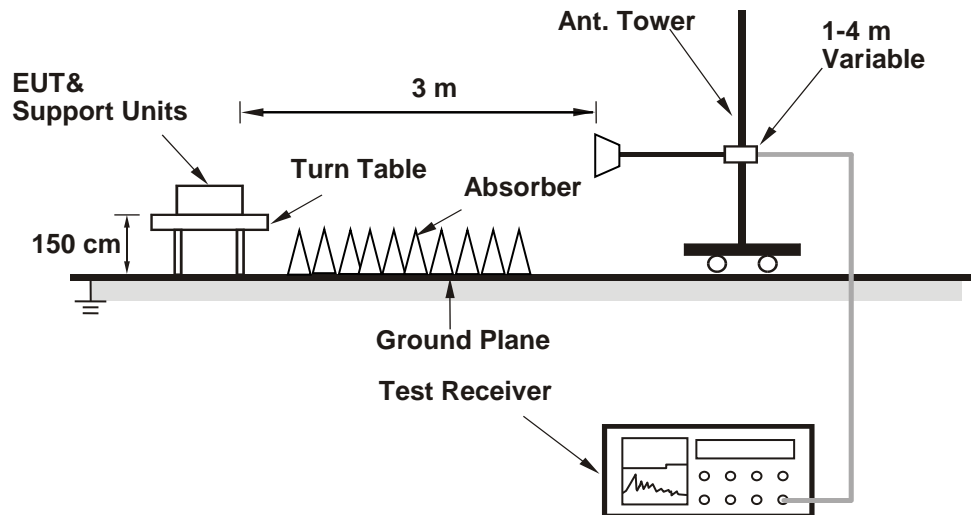

For the actual test configuration, please refer to the attached file (Test Setup Photo).

Test Instruments

Kind of Equipment	Manufacturer	Type	S/N	Calibration Date	Calibration Due Date
Signal Analyzer	R&S	FSV40	101508	2021/3/16	2022/3/15
Receiver	R&S	ESR7	102109	2021/3/16	2022/3/15
Bilog Antenna	SCHWARZBECK	VULB-9168	00951	2021/2/18	2022/2/17
Horn Antenna	ETS-Lindgren	3117	00218930	2020/12/1	2021/11/30
LF-AMP	Agilent	8447D	2944A10772	2021/2/18	2022/2/17
HF-AMP + AC source	EMCI	EMC051845SE	980633	2021/2/9	2022/2/8
HF-AMP + AC source	EMCI	EMC184045SE	980657	2021/2/1	2022/1/31
Horn Antenna	SCHWARZBECK	BBHA 9170	00887	2021/4/8	2022/4/7
Microwave Cable	HUBER+SUHNER	SUCOFLEX 104EA	800056/4EA	2021/3/17	2022/3/16
Microwave Cable	HUBER+SUHNER	SUCOFLEX 104	804680/4	2021/3/17	2022/3/16
Microwave Cable	HUBER+SUHNER	SUCOFLEX 104	MY37202/4	2021/3/17	2022/3/16
Microwave Cable	HUBER+SUHNER	SUCOFLEX 102EA	800898/2EA	2021/4/16	2022/4/15
Microwave Cable	HUBER+SUHNER	SUCOFLEX 102EA	800901/2EA	2021/4/16	2022/4/15
Microwave Cable	HUBER+SUHNER	SUCOFLEX 102EA	801027/2EA	2021/4/16	2022/4/15
Loop Antenna	Chance Most	EMCILPA600 +calibration	287	2021/1/15	2022/1/14

Test Procedures**For Radiated Emissions below 30 MHz**

- a. The EUT was placed on the top of a rotating table 0.8 meters above the ground at a 3 meter chamber room. The table was rotated 360 degrees to determine the position of the highest radiation.
- b. The EUT was set 3 meters away from the interference-receiving antenna, which was mounted on the top of a variable-height antenna tower.
- c. Parallel (OPEN), perpendicular (CLOSE), and ground-parallel (GROUND) orientations of the antenna are set to make the measurement.
- d. For each suspected emission, the EUT was arranged to its worst case and the rotatable table was turned from 0 degrees to 360 degrees to find the maximum reading.
- e. The test-receiver system was set to Quasi-Peak Detect Function and Specified Bandwidth with Maximum Hold Mode.

Note:

1. The resolution bandwidth and video bandwidth of test receiver/spectrum analyzer is 9 kHz at frequency below 30 MHz.
2. All modes of operation were investigated and the worst-case emissions are reported.

For Radiated Emissions above 30 MHz

- a. The EUT was placed on the top of a rotating table 0.8 meters (for 30 MHz ~ 1 GHz) / 1.5 meters (for above 1 GHz) above the ground at 3 meter chamber room for test. The table was rotated 360 degrees to determine the position of the highest radiation.
- b. The EUT was set 3 meters away from the interference-receiving antenna, which was mounted on the top of a variable-height antenna tower.
- c. The height of antenna is varied from one meter to four meters above the ground to determine the maximum value of the field strength. Both horizontal and vertical polarizations of the antenna are set to make the measurement.
- d. For each suspected emission, the EUT was arranged to its worst case and then the antenna was tuned to heights from 1 meter to 4 meters and the rotatable table was turned from 0 degrees to 360 degrees to find the maximum reading.
- e. The test-receiver system was set to quasi-peak detect function and specified bandwidth with maximum hold mode when the test frequency is below 1 GHz.
- f. The test-receiver system was set to peak and average detected function and specified bandwidth with maximum hold mode when the test frequency is above 1 GHz. If the peak reading value also meets average limit, measurement with the average detector is unnecessary.

Note:

1. The resolution bandwidth and video bandwidth of test receiver/spectrum analyzer is 120 kHz for Quasi-peak detection (QP) or Peak detection (PK) at frequency below 1 GHz.
2. The resolution bandwidth of test receiver/spectrum analyzer is 1 MHz and the video bandwidth is 3 MHz for Peak detection (PK) at frequency above 1 GHz.
3. The resolution bandwidth of test receiver/spectrum analyzer is 1 MHz and the video bandwidth is $\geq 1/T$ (Duty cycle < 98 %) or 10 Hz (Duty cycle ≥ 98 %) for Average detection (AV) at frequency above 1 GHz.
4. All modes of operation were investigated and the worst-case emissions are reported.
5. The Radiated Emissions testing was performed in the X(E1), Y(H) and Z(E2) axis orientation. The worst-case Axis orientation is recorded in this test report.

Prüfbericht - Nr.: **CN21YVQP(P15E-WiFi) 001**
Test Report No.

Seite 37 von 44
Page 37 of 44

Test Results

Factor (dB/m) = Antenna Factor (dB/m) + Cable Loss (dB)
Level (dBuV/m) = Reading (dBuV) + Factor (dB/m)

Please refer to Appendix B.

5.1.8 Dynamic Frequency Selection

Limit

<DFS Detection Thresholds for Master Devices and Client Devices with Radar Detection>

Maximum Transmit Power	Value (See Notes 1, 2, and 3)
EIRP \geq 200 milliwatt	-64 dBm
EIRP < 200 milliwatt and power spectral density < 10 dBm/MHz	-62 dBm
EIRP < 200 milliwatt that do not meet the power spectral density requirement	-64 dBm

Note 1: This is the level at the input of the receiver assuming a 0 dBi receive antenna.
 Note 2: Throughout these test procedures an additional 1 dB has been added to the amplitude of the test transmission waveforms to account for variations in measurement equipment. This will ensure that the test signal is at or above the detection threshold level to trigger a DFS response.
 Note 3: EIRP is based on the highest antenna gain. For MIMO devices refer to KDB Publication 662911 D01.

<DFS Response Requirement Values>

Parameter	Value
<i>Non-occupancy period</i>	Minimum 30 minutes
<i>Channel Availability Check Time</i>	60 seconds
<i>Channel Move Time</i>	10 seconds See Note 1.
<i>Channel Closing Transmission Time</i>	200 milliseconds + an aggregate of 60 milliseconds over remaining 10 second period. See Notes 1 and 2.
<i>U-NII Detection Bandwidth</i>	Minimum 100% of the U-NII 99% transmission power bandwidth. See Note 3.

Note 1: *Channel Move Time* and the *Channel Closing Transmission Time* should be performed with Radar Type 0. The measurement timing begins at the end of the Radar Type 0 burst.
 Note 2: The *Channel Closing Transmission Time* is comprised of 200 milliseconds starting at the beginning of the *Channel Move Time* plus any additional intermittent control signals required to facilitate a *Channel* move (an aggregate of 60 milliseconds) during the remainder of the 10 second period. The aggregate duration of control signals will not count quiet periods in between transmissions.
 Note 3: During the *U-NII Detection Bandwidth* detection test, radar type 0 should be used. For each frequency step the minimum percentage of detection is 90 percent. Measurements are performed with no data traffic.

Kind of Test Site Shielded room

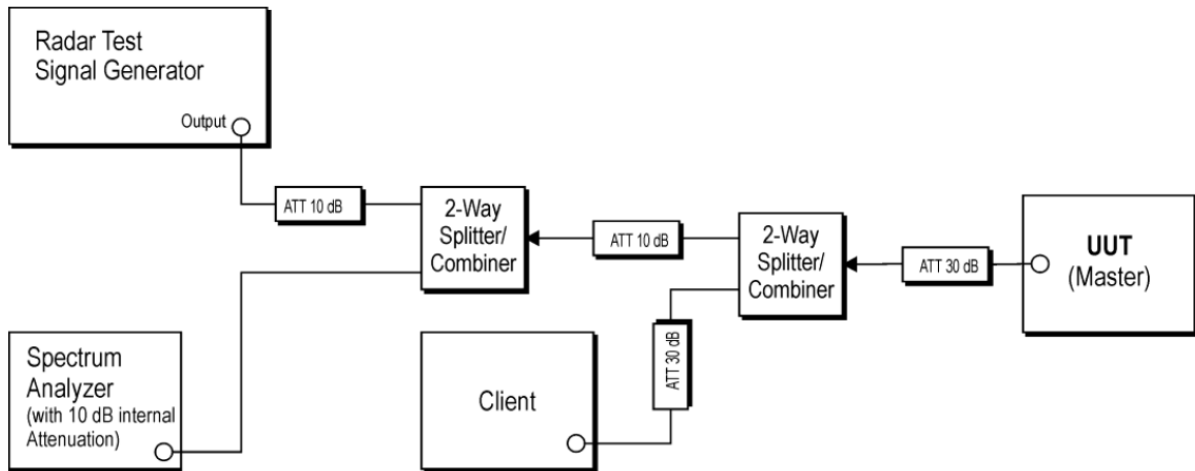
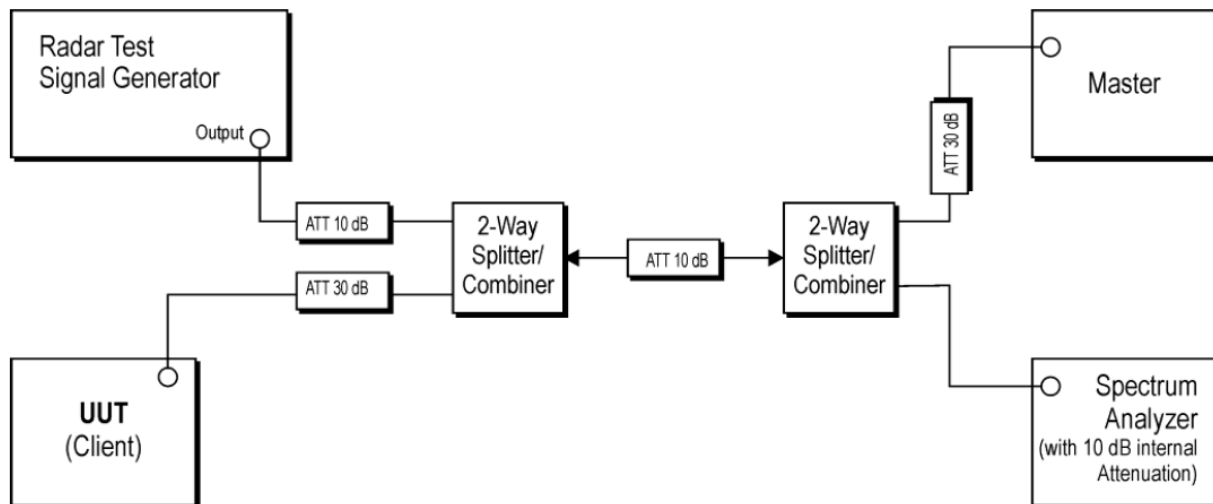
Test Setup
<Setup for Master with injection at the Master>

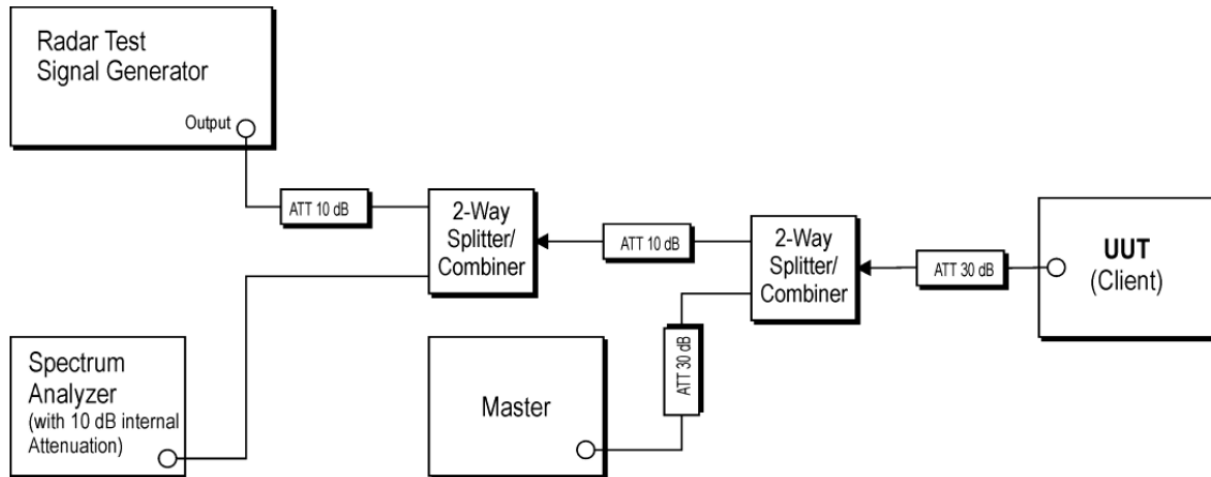
<Setup for Client with injection at the Master>

<Setup for Client with injection at the Client>

Test Instruments

Kind of Equipment	Manufacturer	Type	S/N	Calibration Date	Calibration Due Date	Test Date	
						From	Until
Spectrum Analyzer	Agilent	N9010A	MY53470241	2021/6/15	2022/6/14	2021/9/3	2021/9/4
MXG Vector Signal Generator	Agilent	N5182B	MY53050525	2021/3/25	2022/3/24	2021/9/3	2021/9/4

Requirement

Requirement	Operational Mode	
	Master Device or Client with Radar Detection	Client Without Radar Detection
<i>DFS Detection Threshold</i>	Yes	Not required
<i>Channel Closing Transmission Time</i>	Yes	Yes
<i>Channel Move Time</i>	Yes	Yes
<i>U-NII Detection Bandwidth</i>	Yes	Not required

Additional requirements for devices with multiple bandwidth modes	Master Device or Client with Radar Detection	Client Without Radar Detection
<i>U-NII Detection Bandwidth and Statistical Performance Check</i>	All BW modes must be tested	Not required
<i>Channel Move Time and Channel Closing Transmission Time</i>	Test using widest BW mode available	Test using the widest BW mode available for the link
<i>All other tests</i>	Any single BW mode	Not required

Note: Frequencies selected for statistical performance check (Section 7.8.4) should include several frequencies within the radar detection bandwidth and frequencies near the edge of the radar detection bandwidth. For 802.11 devices it is suggested to select frequencies in each of the bonded 20 MHz channels and the channel center frequency.

Channel Moving Time

Channel (MHz)	Channel Move Time (s)	Limit (s)	Result
5530	0.46	10	Pass

Channel Closing Transmission Time

Channel (MHz)	Channel Closing Transmission Time (ms)	Limit (ms)	Result
5530	10	200	Pass

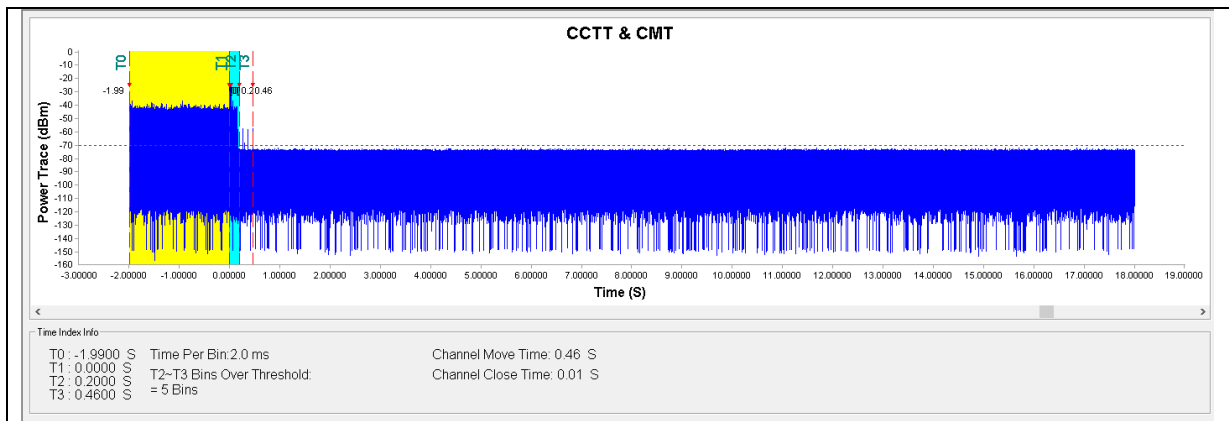
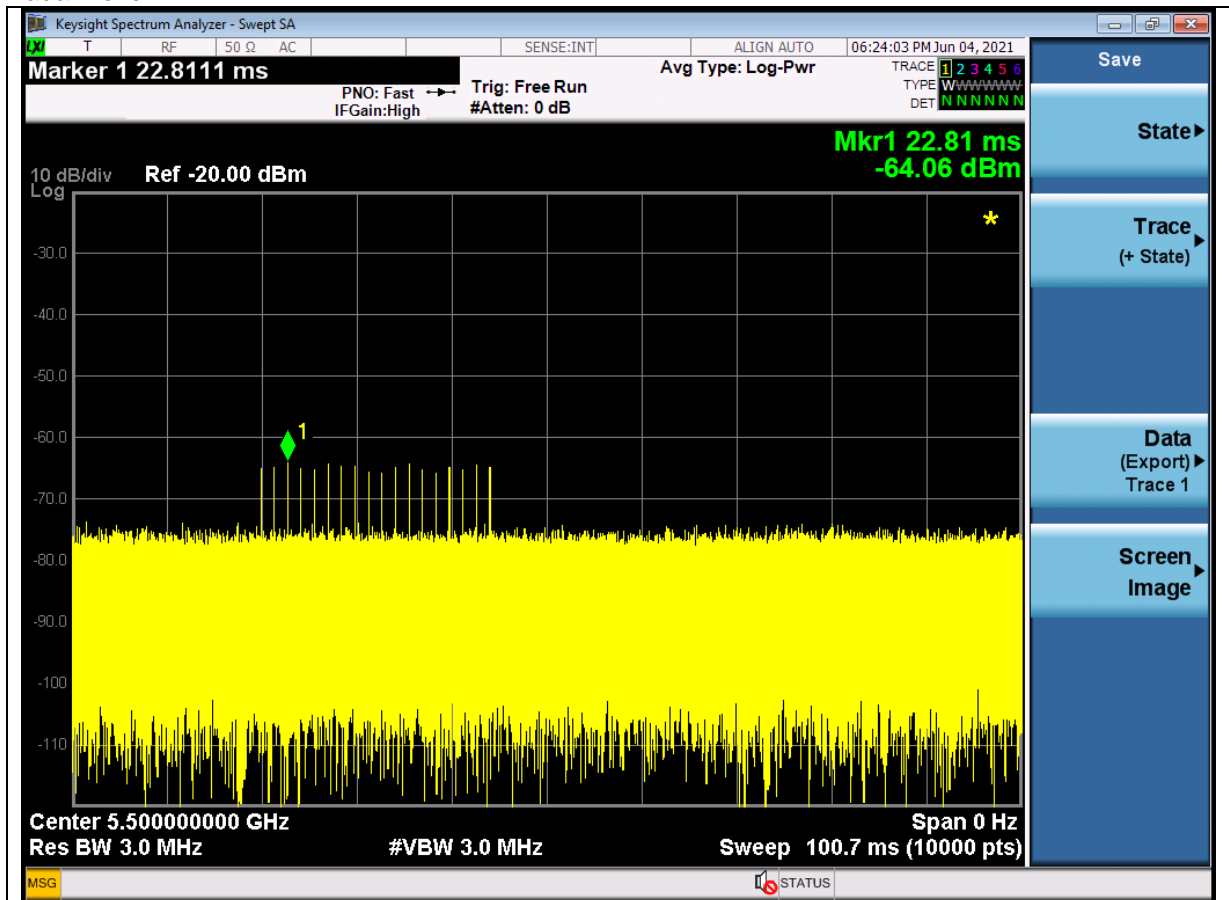
Radar Level

5.2 Mains Emission

5.2.1 Mains Conducted Emission

Limit

Mains Conducted emissions as defined in §15.207 must comply with the mains conducted emission limits.

Kind of Test Site Shielded room

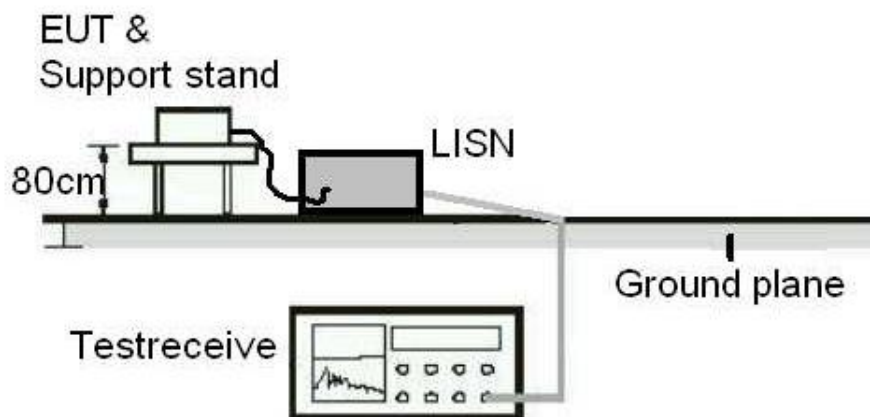
Test Setup

Test Instruments

Kind of Equipment	Manufacturer	Type	S/N	Calibration Date	Calibration Due Date
TWO-LINE V-NETWORK	R&S	ENV216	1816064	2020/9/10	2021/9/9
EMI Test Receiver	R&S	ESCI	1816063	2020/11/17	2021/11/16
RF Cable	N/A	N/A	EMC-003	2020/11/15	2021/11/14

Test Procedures

- a. The EUT was placed 0.4 meters from the conducting wall of the shielded room with EUT being connected to the power mains through a line impedance stabilization network (LISN). Other support units were connected to the power mains through another LISN. The two LISNs provide 50 ohm/50 uH of coupling impedance for the measuring instrument.
- b. Both lines of the power mains connected to the EUT were checked for maximum conducted interference.
- c. The frequency range from 150 kHz to 30 MHz was searched. Emission levels under (Limit – 20 dB) was not recorded.

Note: The resolution bandwidth and video bandwidth of test receiver is 9 kHz for quasi-peak detection (QP) and average detection (AV) at frequency 0.15 MHz – 30 MHz.

Test Results

Please refer to Appendix B.