



<b>Prüfbericht-Nr.:</b> <i>Test report no.:</i>	CN21YVQP(FCC-Colocated) 001	<b>Auftrags-Nr.:</b> <i>Order no.:</i>	238518387	Seite 1 von 16 Page 1 of 16
<b>Kunden-Referenz-Nr.:</b> <i>Client reference no.:</i>	N/A	<b>Auftragsdatum:</b> <i>Order date:</i>	2021-08-02	
<b>Auftraggeber:</b> <i>Client:</i>	Hon Hai Precision Industry Co., Ltd. No.151, Sec. 1, Nankan Rd., Lujhu Dist., Taoyuan City 33859, Taiwan (R.O.C.)			
<b>Prüfgegenstand:</b> <i>Test item:</i>	802.11a/b/g/n/ac WLAN 2T2R + BT v5.1 Combo Module			
<b>Bezeichnung / Typ-Nr.:</b> <i>Identification / Type no.:</i>	WBU063-VZ			
<b>Auftrags-Inhalt:</b> <i>Order content:</i>	Spot Checking Emissions (FCC)			
<b>Prüfgrundlage:</b> <i>Test specification:</i>	FCC 47CFR Part 15: Subpart C Section 15.247 FCC 47CFR Part 15: Subpart E Section 15.407			
<b>Wareneingangsdatum:</b> <i>Date of sample receipt:</i>	2021-08-03			
<b>Prüfmuster-Nr.:</b> <i>Test sample no.:</i>	A003103482-001			
<b>Prüfzeitraum:</b> <i>Testing period:</i>	2021-08-20 - 2021-09-10			
<b>Ort der Prüfung:</b> <i>Place of testing:</i>	EMC/RF Taipei Testing Site			
<b>Prüflaboratorium:</b> <i>Testing laboratory:</i>	Taipei Testing Laboratories			
<b>Prüfergebnis*:</b> <i>Test result*:</i>	Pass			
<b>überprüft von:</b> <i>compiled by:</i>		<b>genehmigt von:</b> <i>authorized by:</i>		
<b>Datum:</b> <i>Date:</i> 2021-09-11	David Huang	<b>Ausstellungsdatum:</b> <i>Issue date:</i> 2021-09-11	Brenda Chen	
<b>Stellung / Position:</b>	Project Manager	<b>Stellung / Position:</b>	Senior Project Manager	
<b>Sonstiges / Other:</b>				
<b>Zustand des Prüfgegenstandes bei Anlieferung:</b> <i>Condition of the test item at delivery:</i>	Prüfmuster vollständig und unbeschädigt <i>Test item complete and undamaged</i>			
* Legende:	1 = sehr gut P(ass) = entspricht o.g. Prüfgrundlage(n)	2 = gut F(ail) = entspricht nicht o.g. Prüfgrundlage(n)	3 = befriedigend 4 = ausreichend N/A = nicht anwendbar	5 = mangelhaft N/T = nicht getestet
* Legend:	1 = very good P(ass) = passed a.m. test specification(s)	2 = good F(ail) = failed a.m. test specification(s)	3 = satisfactory 4 = sufficient N/A = not applicable	5 = poor N/T = not tested
<b>Dieser Prüfbericht bezieht sich nur auf das o.g. Prüfmuster und darf ohne Genehmigung der Prüfstelle nicht auszugsweise vervielfältigt werden. Dieser Bericht berechtigt nicht zur Verwendung eines Prüfzeichens.</b> <i>This test report only relates to the a. m. test sample. Without permission of the test center this test report is not permitted to be duplicated in extracts. This test report does not entitle to carry any test mark.</i>				

v05

## TEST SUMMARY

Report Section	FCC Clause	Test Item	Result
5.1.1	15.247(d) & 15.407(b) & 15.205 & 15.209	Radiated Spurious Emissions and Band Edges	Pass

**Note:** Determining compliance based on the results of the compliance measurement, not taking into account measurement instrumentation uncertainty.

## Contents

<b>HISTORY OF THIS TEST REPORT .....</b>	<b>4</b>
<b>1. GENERAL REMARKS .....</b>	<b>5</b>
<b>1.1 COMPLEMENTARY MATERIALS.....</b>	<b>5</b>
<b>1.2 DECISION RULE OF CONFORMITY .....</b>	<b>5</b>
<b>2. TEST SITES .....</b>	<b>6</b>
<b>2.1 TEST LABORATORY .....</b>	<b>6</b>
<b>2.2 TEST FACILITY.....</b>	<b>6</b>
<b>2.3 TRACEABILITY .....</b>	<b>7</b>
<b>2.4 CALIBRATION .....</b>	<b>7</b>
<b>2.5 MEASUREMENT UNCERTAINTY .....</b>	<b>7</b>
<b>3. GENERAL PRODUCT INFORMATION.....</b>	<b>8</b>
<b>3.1 PRODUCT FUNCTION AND INTENDED USE .....</b>	<b>8</b>
<b>3.2 SYSTEM DETAILS AND RATINGS.....</b>	<b>8</b>
<b>3.3 NOISE GENERATING AND NOISE SUPPRESSING PARTS .....</b>	<b>8</b>
<b>3.4 SUBMITTED DOCUMENTS.....</b>	<b>8</b>
<b>4. TEST SET-UP AND OPERATION MODES.....</b>	<b>9</b>
<b>4.1 PRINCIPLE OF CONFIGURATION SELECTION .....</b>	<b>9</b>
<b>4.2 TEST OPERATION AND TEST SOFTWARE.....</b>	<b>10</b>
<b>4.3 SPECIAL ACCESSORIES AND AUXILIARY EQUIPMENT .....</b>	<b>11</b>
<b>4.4 TEST SETUP DIAGRAM .....</b>	<b>11</b>
<b>5. TEST RESULTS .....</b>	<b>12</b>
<b>5.1 TRANSMITTER REQUIREMENT &amp; TEST SUITES .....</b>	<b>12</b>
5.1.1 <i>Radiated Spurious Emissions .....</i>	<i>12</i>

**APPENDIX A - TEST RESULT OF RADIATED SPURIOUS EMISSIONS**

**APPENDIX SP - PHOTOGRAPHS OF TEST SETUP**

### HISTORY OF THIS TEST REPORT

Report No.	Description	Date Issued
CN21YVQP(FCC-Colocated) 001	Original Release	2021-09-11

## 1. General Remarks

### 1.1 Complementary Materials

All attachments are integral parts of this test report. This applies especially to the following appendix:

**Appendix A - Test Result of Radiated Spurious Emissions**

**Appendix SP - Photographs of Test Setup**

### Applied Standard and Test Levels

Radio
FCC CFR47 Part 15: Subpart C Section 15.247
FCC CFR47 Part 15: Subpart E Section 15.407
FCC CFR47 Part 2: Subpart J Section 2.1091
ANSI C63.10:2013
KDB 558074 D01 15.247 Meas Guidance v05r02
KDB 996369 D04 Module Integration Guide v01

### 1.2 Decision Rule of Conformity

The decision rule of conformity of this test report is following the requirements of the requested standard in the quotation, and agreed among testing laboratory and manufacturer (applicant) to exclude the consideration of Measurement Uncertainty, unless it is required by the specific standard.

## 2. Test Sites

### 2.1 Test Laboratory

Taipei Testing Laboratories

11F. No.758, Sec. 4, Bade Rd., Songshan Dist.  
Taipei City 105  
Taiwan (R.O.C.)

### 2.2 Test Facility

Taipei Testing Laboratories

No.458-18, Sec. 2, Fenliao Rd., Linkou Dist.,  
New Taipei City 244  
Taiwan (R.O.C.)  
FCC Registration No.: 226631  
ISED Registration No.: 25563

## 2.3 Traceability

All measurement equipment calibrations are traceable to NML(Taiwan)/NIST(USA) or where calibration is performed outside Taiwan, to equivalent nationally recognized standards organizations.

## 2.4 Calibration

Equipment requiring calibration is calibrated periodically in a suitably accredited Calibration Lab. Additionally all equipment is verified for proper performance on a regular basis using in house standards or comparisons.

## 2.5 Measurement Uncertainty

All measurement uncertainty values are shown with a coverage factor of  $k=2$  to indicate a 95% level of confidence.

### Emission Measurement Uncertainty

Parameter	Uncertainty
Radiated Emission (9 kHz ~ 30 MHz)	$\pm 1.15$ dB
Radiated Emission (30 MHz ~ 200 MHz)	$\pm 1.30$ dB
Radiated Emission (200 MHz ~ 1 GHz)	$\pm 1.30$ dB
Radiated Emission (1 GHz ~ 18 GHz)	$\pm 1.54$ dB
Radiated Emission (18 GHz ~ 40 GHz)	$\pm 2.52$ dB
Mains Conducted Emission	$\pm 1.65$ dB

### 3. General Product Information

#### 3.1 Product Function and Intended Use

The EUT is a 802.11a/b/g/n/ac WLAN 2T2R + BT v5.1 Combo Module. It contains a Bluetooth/WLAN compatible module enabling the user to communicate data through a Wireless interface.

For details refer to the User Guide, Data Sheet and Circuit Diagram.

#### 3.2 System Details and Ratings

##### Basic Information of EUT

Item	EUT information
Kind of Equipment/Test Item	802.11a/b/g/n/ac WLAN 2T2R + BT v5.1 Combo Module
Type Identification	WBU063-VZ
FCC ID	RX3-WBU063VZ

##### Technical Specification of EUT

Item	EUT information
Operating Frequency	Bluetooth: 2402 ~ 2480 MHz WLAN 2.4GHz: 2412 ~ 2462 MHz WLAN 5GHz: 5180 ~ 5240 MHz; 5260 ~ 5320 MHz; 5500 ~ 5720 MHz; 5745 ~ 5825 MHz
Operation Voltage	5 Vdc
Modulation	Bluetooth: GFSK Bluetooth LE: GFSK, $\pi/4$ -DQPSK, 8DPSK WLAN: DSSS, OFDM
Accessory Device	Refer to 4.3

#### 3.3 Noise Generating and Noise Suppressing Parts

Refer to the Circuit Diagram.

#### 3.4 Submitted Documents

- Circuit Diagram
- Instruction Manual
- Rating Label
- Technical Description



## **4. Test Set-up and Operation Modes**

### **4.1 Principle of Configuration Selection**

The test modes were adapted accordingly in reference to the instructions for use.

During testing, Channel and Power Controlling Software provided by the customer was used to control the operating channel as well as the output power level. The RF output power selection is for the setting of RF output expected by the customer and is going to be fixed on the firmware of the final end product.

## 4.2 Test Operation and Test Software

Setup for testing: The test sample itself is equipped with a touch screen. It was used to enable the operation modes listed as below.

The samples were used as follows:

A003103482-001

Full test was applied on all test modes, but only worst case was shown.

EUT Configure Mode	Applicable To	Description
	Radiated Spurious Emissions	
-	√	-

Note:

1. The EUT had been pre-tested on the positioned of each 3 axis. The worst case was found when position on **X-plane**.
2. "-" means no effect.

### Radiated Spurious Emissions

- Pre-Scan full test was applied on all test modes, but only worst case was shown.
- Following channel(s) was (were) selected for the final test as listed below.

EUT Configure Mode
BT_8DPSK_2480 MHz + 802.11b_2412 MHz
BT_8DPSK_2480 MHz + 802.11ac_5530 MHz
BT LE_2M_2480 MHz + 802.11b_2412 MHz
BT LE_2M_2480 MHz + 802.11ac_5530 MHz

Note: For Bluetooth, the ANT 1 (SN: 6903B000P000) was chosen for the final test due to the worst case.

### Test Condition

Test Item	Ambient Temperature	Relative Humidity	Tested by
Radiated Spurious Emissions	23.1-25.1 °C	50-60 %	Simon Tsai

### 4.3 Special Accessories and Auxiliary Equipment

The product has been tested together with the following additional accessories:

#### Accessory of EUT

None

#### Support Unit

No.	Description	Brand	Model	S/N	Remark
Radiated Test					
1	USB Cable	Pro-best	MK-USBMF-3M	-	300 m shielded cable w/o core
2	Notebook	HP	15s-du0007TX	CND93662VF	-

### 4.4 Test Setup Diagram

<Radiated Spurious Emissions Tx mode >

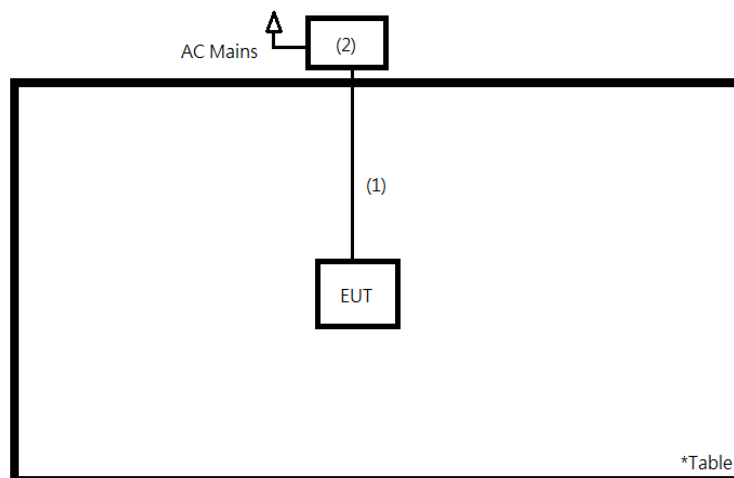

## 5. Test Results

### 5.1 Transmitter Requirement & Test Suites

#### 5.1.1 Radiated Spurious Emissions

##### Limit

The power of any emission outside of the authorized operating frequency ranges must be attenuated below the transmitting power (P) by a factor of at least  $43 + 10 \log(P)$  dB.

**Kind of Test Site**                      3m Semi-Anechoic Chamber

##### Test Setup

<Radiated Emissions below 30 MHz>

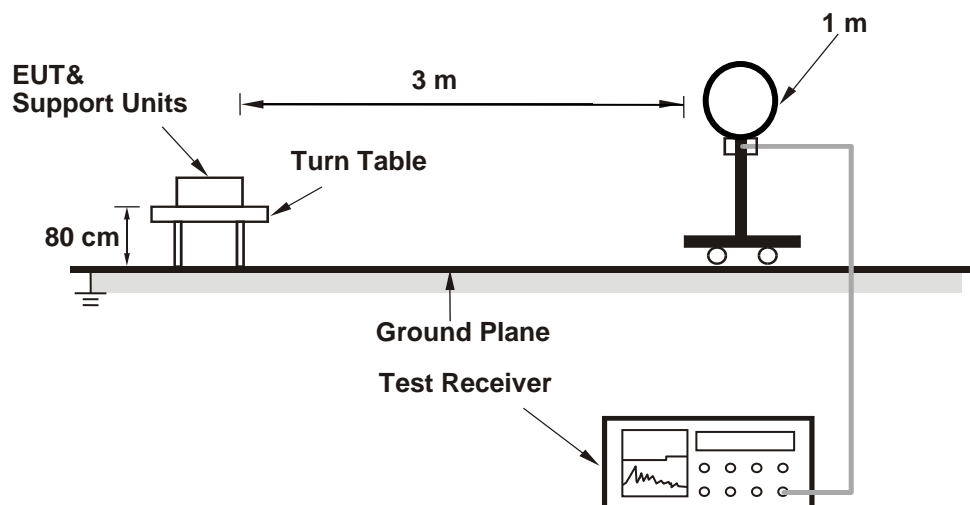

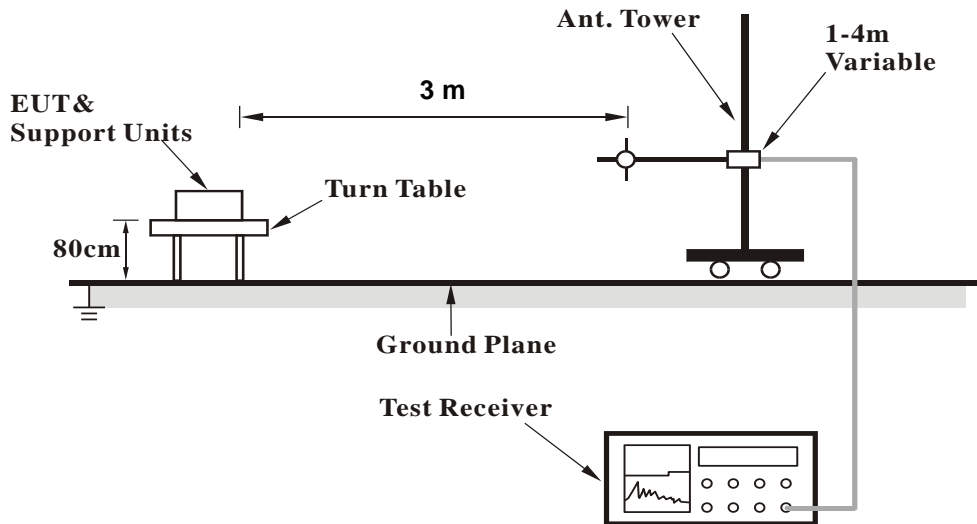
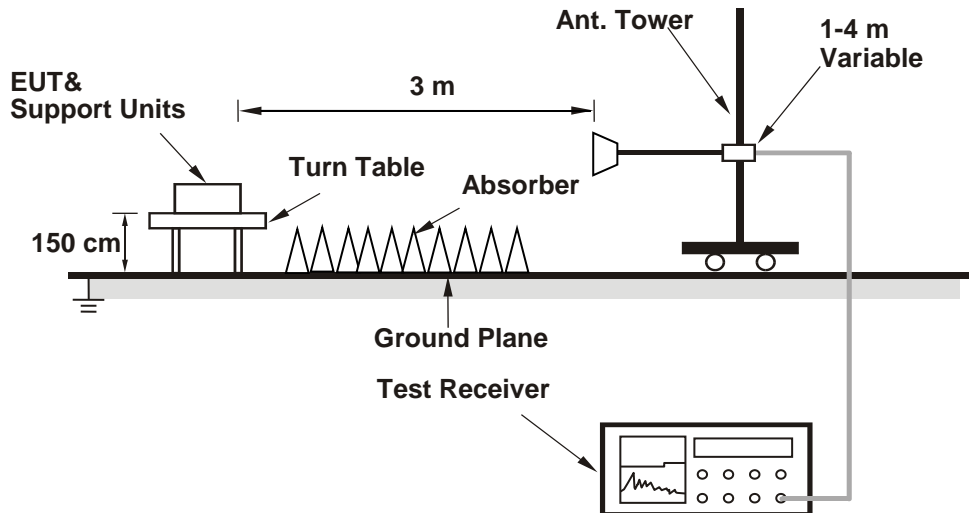
**<Radiated Emissions 30 MHz to 1 GHz>**

**<Radiated Emissions above 1 GHz>**

For the actual test configuration, please refer to the attached file (Test Setup Photo).

**Test Instruments**

Kind of Equipment	Manufacturer	Type	S/N	Calibration Date	Calibration Due Date
Signal Analyzer	R&S	FSV40	101508	2021/3/16	2022/3/15
Receiver	R&S	ESR7	102109	2021/3/16	2022/3/15
Bilog Antenna	SCHWARZBECK	VULB-9168	00951	2021/2/18	2022/2/17
Horn Antenna	ETS-Lindgren	3117	00218930	2020/12/1	2021/11/30
LF-AMP	Agilent	8447D	2944A10772	2021/2/18	2022/2/17
HF-AMP + AC source	EMCI	EMC051845SE	980633	2021/2/9	2022/2/8
HF-AMP + AC source	EMCI	EMC184045SE	980657	2021/2/1	2022/1/31
Horn Antenna	SCHWARZBECK	BBHA 9170	00887	2021/4/8	2022/4/7
Microwave Cable	HUBER+SUHNER	SUCOFLEX 104EA	800056/4EA	2021/3/17	2022/3/16
Microwave Cable	HUBER+SUHNER	SUCOFLEX 104	804680/4	2021/3/17	2022/3/16
Microwave Cable	HUBER+SUHNER	SUCOFLEX 104	MY37202/4	2021/3/17	2022/3/16
Microwave Cable	HUBER+SUHNER	SUCOFLEX 102EA	800898/2EA	2021/4/16	2022/4/15
Microwave Cable	HUBER+SUHNER	SUCOFLEX 102EA	800901/2EA	2021/4/16	2022/4/15
Microwave Cable	HUBER+SUHNER	SUCOFLEX 102EA	801027/2EA	2021/4/16	2022/4/15
Loop Antenna	Chance Most	EMCILPA600 +calibration	287	2021/1/15	2022/1/14

**Test Procedures****For Radiated Emissions below 30 MHz**

- a. The EUT was placed on the top of a rotating table 0.8 meters above the ground at a 3 meter chamber room. The table was rotated 360 degrees to determine the position of the highest radiation.
- b. The EUT was set 3 meters away from the interference-receiving antenna, which was mounted on the top of a variable-height antenna tower.
- c. Parallel, perpendicular, and ground-parallel orientations of the antenna are set to make the measurement.
- d. For each suspected emission, the EUT was arranged to its worst case and the rotatable table was turned from 0 degrees to 360 degrees to find the maximum reading.
- e. The test-receiver system was set to Quasi-Peak Detect Function and Specified Bandwidth with Maximum Hold Mode.

**Note:** The resolution bandwidth and video bandwidth of test receiver/spectrum analyzer is 9 kHz at frequency below 30 MHz.

**For Radiated Emissions above 30 MHz**

- a. The EUT was placed on the top of a rotating table 0.8 meters (for 30 MHz ~ 1 GHz) / 1.5 meters (for above 1 GHz) above the ground at 3 meter chamber room for test. The table was rotated 360 degrees to determine the position of the highest radiation.
- b. The EUT was set 3 meters away from the interference-receiving antenna, which was mounted on the top of a variable-height antenna tower.
- c. The height of antenna is varied from one meter to four meters above the ground to determine the maximum value of the field strength. Both horizontal and vertical polarizations of the antenna are set to make the measurement.
- d. For each suspected emission, the EUT was arranged to its worst case and then the antenna was tuned to heights from 1 meter to 4 meters and the rotatable table was turned from 0 degrees to 360 degrees to find the maximum reading.
- e. The test-receiver system was set to quasi-peak detect function and specified bandwidth with maximum hold mode when the test frequency is below 1 GHz.
- f. The test-receiver system was set to peak and average detected function and specified bandwidth with maximum hold mode when the test frequency is above 1 GHz. If the peak reading value also meets average limit, measurement with the average detector is unnecessary.

**Note:**

1. The resolution bandwidth and video bandwidth of test receiver/spectrum analyzer is 120 kHz for Quasi-peak detection (QP) or Peak detection (PK) at frequency below 1 GHz.
2. The resolution bandwidth of test receiver/spectrum analyzer is 1 MHz and the video bandwidth is 3 MHz for Peak detection (PK) at frequency above 1 GHz.
3. The resolution bandwidth of test receiver/spectrum analyzer is 1 MHz and the video bandwidth is  $\geq 1/T$  (Duty cycle < 98 %) or 10 Hz (Duty cycle  $\geq 98$  %) for Average detection (AV) at frequency above 1 GHz.
4. All modes of operation were investigated and the worst-case emissions are reported.
5. The Radiated Emissions testing was performed in the X(E1), Y(H) and Z(E2) axis orientation. The worst-case Axis orientation is recorded in this test report.

**Test Results**

Factor (dB/m) = Antenna Factor (dB/m) + Cable Loss (dB)  
Level (dBuV/m) = Reading (dBuV) + Factor (dB/m)

Please refer to Appendix A.