



FCC PART 15 TEST REPORT No.I22Z60808-IOT07

for

Razer Inc.

Gaming Tablet

RZ45-0460VWQ

With

FCC ID: RWO-RZ450460

Hardware Version: V4

Software Version: Razer Edge 5G-12-user

Issued Date: 2022-09-29

Note:

The test results in this test report relate only to the devices specified in this report. This report shall not be reproduced except in full without the written approval of CTTL.

The report must not be used by the client to claim product certification, approval, or endorsement by NVLAP, NIST, or any agency of the U.S. Government.

Test Laboratory:

CTTL-Telecommunication Technology Labs, CAICT

No. 52, Huayuan North Road, Haidian District, Beijing, P. R. China 100191.

Tel:+86(0)10-62304633-2512, Fax:+86(0)10-62304633-2504

Email: ctl_terminals@caict.ac.cn, website: www.caict.ac.cn

REPORT HISTORY

Report Number	Revision	Description	Issue Date
I22Z60808-IOT07	Rev.0	1st edition	2022-08-05
I22Z60808-IOT07	Rev.1	Add the power result graph. Add the PSD result graph.	2022-08-26
I22Z60808-IOT07	Rev.2	Update the result table of PSD. Add the result of 11ax80-RU26-index0 and 11ax160-RU26-index0. Add the stamen on page 26. Update the result of Contention Based Protocol.	2022-09-29

CONTENTS

CONTENTS	3
1. TEST LATORATORY	5
1.1. INTRODUCTION & ACCREDITATION	5
1.2. TESTING LOCATION	5
1.3. TESTING ENVIRONMENT.....	5
1.4. PROJECT DATE	5
1.5. SIGNATURE	5
2. CLIENT INFORMATION.....	6
2.1 APPLICANT INFORMATION.....	6
2.2 MANUFACTURER INFORMATION.....	6
3. EQUIPMENT UNDER TEST (EUT) AND ANCILLARYEQUIPMENT(AE).....	7
3.1. ABOUT EUT	7
3.2. INTERNAL IDENTIFICATION OF EUT USED DURING THE TEST	7
3.3. INTERNAL IDENTIFICATION OF AE USED DURING THE TEST.....	7
3.4. GENERAL DESCRIPTION.....	7
3.5. INTERPRETATION OF THE TEST ENVIRONMENT.....	8
4. REFERENCE DOCUMENTS	8
4.1. DOCUMENTS SUPPLIED BY APPLICANT	8
4.2. REFERENCE DOCUMENTS FOR TESTING.....	8
5. LABORATORY ENVIRONMENT.....	8
6. SUMMARY OF TEST RESULTS	9
6.1. SUMMARY OF TEST RESULTS.....	9
6.2. STATEMENTS.....	9
6.3. TEST CONDITIONS	9
7. TEST EQUIPMENTS UTILIZED	10
8. MEASUREMENT UNCERTAINTY	11
8.1 TRANSMITTER OUTPUT POWER.....	11
8.2 PEAK POWER SPECTRAL DENSITY.....	11
8.3 99% OCCUPIED BANDWIDTH.....	11
8.4 OCCUPIED CHANNEL BANDWIDTH.....	11
8.5 BAND EDGES COMPLIANCE.....	11
8.6 SPURIOUS EMISSIONS	11
8.7 AC POWER-LINE CONDUCTED EMISSION	11
ANNEX A: MEASUREMENT RESULTS.....	12
A.1. MEASUREMENT METHOD	12



A.2. MAXIMUM OUTPUT POWER 14

A.3. PEAK POWER SPECTRAL DENSITY (CONDUCTED)..... 26

A.4. OCCUPIED 26DB BANDWIDTH(CONDUCTED)..... 31

A.5. 99% OCCUPIED BANDWIDTH 54

A.6. CONTENTION BASED PROTOCOL 77

A.7. IN-BAND EMISSIONS..... 82

A.8. TRANSMITTER SPURIOUS EMISSION117

A.9. BAND EDGES COMPLIANCE 152

A.9.1 BAND EDGES - RADIATED..... 152

A.10. AC POWERLINE CONDUCTED EMISSION (150KHZ- 30MHZ)..... 158

ANNEX B: EUT PARAMETERS..... 161

ANNEX C: ACCREDITATION CERTIFICATE 161

1. TEST LABORATORY

1.1. Introduction & Accreditation

Telecommunication Technology Labs, CAICT is an ISO/IEC 17025:2017 accredited test laboratory under NATIONAL VOLUNTARY LABORATORY ACCREDITATION PROGRAM (NVLAP) with lab code 600118-0, and is also an FCC accredited test laboratory (CN5017), and ISED accredited test laboratory (ISED#: 24849). The detail accreditation scope can be found on NVLAP website.

1.2. Testing Location

Testing Location: CTTL(Huayuan North Road)

Address: No. 52, Huayuan North Road, Haidian District, Beijing, P. R. China 100191

1.3. Testing Environment

Normal Temperature: 15-35°C

Relative Humidity: 20-75%

1.4. Project date

Testing Start Date: 2022-04-20

Testing End Date: 2022-09-29

1.5. Signature

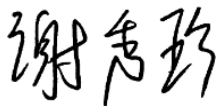

Xie Xiuzhen

(Prepared this test report)

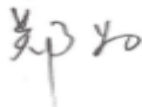

Zheng Wei

(Reviewed this test report)



Hu Xiaoyu

(Approved this test report)



2. CLIENT INFORMATION

2.1 Applicant Information

Company Name: Razer Inc.
Address /Post: 9 Pasteur, Suite 100, Irvine, CA 92618, USA.
Contact: Johnsen Tia
Email: Johnsen.tia@razer.com
Telephone: +65 6571 6828

2.2 Manufacturer Information

Company Name: Razer Inc.
Address /Post: 9 Pasteur, Suite 100, Irvine, CA 92618, USA.
Contact: Johnsen Tia
Email: Johnsen.tia@razer.com
Telephone: +65 6571 6828

3. EQUIPMENT UNDER TEST (EUT) AND ANCILLARY EQUIPMENT(AE)

3.1. About EUT

Description	Gaming Tablet
Model name	RZ45-0460VWQ
FCC ID	RWO-RZ450460
WLAN Frequency Band	ISM Bands: -5925MHz~6425MHz -6425MHz~6525MHz -6525MHz~6875MHz -6875MHz~7125MHz
Type of modulation	OFDM/OFDMA
Antenna	Embedded Antenna
Voltage	3.87V
Equipment class	Indoor client

3.2. Internal Identification of EUT used during the test

EUT ID*	SN or IMEI	HW Version	SW Version
UT65a	867034040041429	V4	Razer Edge 5G-12-user
UT35a	867034040041816	V4	Razer Edge 5G-12-user

*EUT ID: is used to identify the test sample in the lab internally.

* UT35a is used for Conduction test, UT65ais used for Radiation test.

3.3. Internal Identification of AE used during the test

AE ID*	Description	Type	SN
AE1	Battery	/	CAC4060002C2
AE2	Dummy battery	/	/
AE3	USB Cable	/	LS2-A001A
AE4	Adapter	/	A849-200225C-US 1

*AE ID: is used to identify the test sample in the lab internally.

3.4. General Description

The Equipment under Test (EUT) is a model of Gaming Tablet with embedded antenna and inbuilt battery.

It consists of normal options: travel charger, USB cable.

Manual and specifications of the EUT were provided to fulfil the test.

Samples undergoing test were selected by the client.

3.5. Interpretation of the Test Environment

For the test methods, the test environment uncertainty figures correspond to an expansion factor $k=2$.

Measurement Uncertainty

Parameter	Uncertainty
temperature	0.48°C
humidity	2 %
DC voltages	0.003V

4. REFERENCE DOCUMENTS

4.1. Documents supplied by applicant

EUT feature information is supplied by the applicant or manufacturer, which is the basis of testing.

4.2. Reference Documents for testing

The following documents listed in this section are referred for testing.

FCC Part15	Title 47 of the Code of Federal Regulations; Chapter I Part 15 - Radio frequency devices	2018
ANSI C63.10	Methods of Measurement of Radio-Noise Emissions from Low-Voltage Electrical and Electronic Equipment in the Range of 9 kHz to 40 GHz	2013
UNII: KDB 789033 D02	General U-NII Test Procedures New Rules v02r01	2017-12
KDB 987594 D02	GUIDELINES FOR COMPLIANCE TESTING OF UNLICENSED NATIONAL INFORMATION INFRASTRUCTURE 6 GHz (U-NII) DEVICES PART 15, SUBPART E	2021-02
KDB 662911 D01	Emissions Testing of Transmitters with Multiple Outputs in the Same Band(e.g., MIMO, Smart Antenna, etc)	2013-10

5. LABORATORY ENVIRONMENT

Conducted RF performance testing is performed in shielding room.

EMC performance testing is performed in Semi-anechoic chamber.

6. SUMMARY OF TEST RESULTS

6.1. Summary of Test Results

SUMMARY OF MEASUREMENT RESULTS	Sub-clause of Part15E	Sub-clause of IC	Verdict
Maximum Output Power	15.407	/	P
Peak Power Spectral Density	15.407	/	P
Occupied 26dB Bandwidth	15.403	/	P
99% Occupied bandwidth	/	/	P
Contention Based Protocol	/	/	P
In-Band Emissions	/	/	P
Band edge compliance (Radiated)	15.209,15.407	/	P
AC Powerline Conducted Emission (150kHz- 30MHz)	15.107, 15.207	/	P
Transmitter spurious emissions(Radiated)	15.407	/	P

Please refer to **ANNEX A** for detail.

Terms used in Verdict column

P	Pass, The EUT complies with the essential requirements in the standard.
NM	Not measured, The test was not measured by CTTL
NA	Not Applicable, The test was not applicable
F	Fail, The EUT does not comply with the essential requirements in the standard

6.2. Statements

CTTL has evaluated the test cases requested by the client/manufacturer as listed in section 6.1 of this report for the EUT specified in section 3 according to the standards or reference documents listed in section 4.2.

This report only deals with the WLAN function among the features described in section 3.

KDB 987594 is not accredited by the NVLAP.

6.3. Test Conditions

For this report, all the test cases are tested under normal temperature and normal voltage, and also under norm humidity, the specific condition is shown as follows:

Temperature	26°C
Voltage	3.87V
Humidity	44%

7. TEST EQUIPMENTS UTILIZED

Conducted test system

No.	Equipment	Model	Serial Number	Manufacturer	Calibration Period	Calibration Due date
1	Vector Signal Analyzer	FSQ40	200089	Rohde & Schwarz	1 year	2023-05-15
	Vector Signal Generator	SMW200A	103421	Rohde & Schwarz	1 year	2023-05-15
2	Test Receiver	ESCI 3	100344	Rohde & Schwarz	1 year	2023-02-21
3	LISN	ENV216	101200	Rohde & Schwarz	1 year	2022-06-29
4	Attenuator	10dB/2W	/	Rosenberger	/	/
5	Shielding Room	S81	/	ETS-Lindgren	/	/

Note:

The test dates were before the calibration due dates of equipment used (the LISN which series number is 101200)

Instrument	Brand Name	Model
WLAN AP	ASUS	GT-AXE11000

Radiated emission test system

No.	Equipment	Model	Serial Number	Manufacturer	Calibration Period	Calibration Due date
1	Test Receiver	ESW44	103023	Rohde & Schwarz	1 year	2022-10-28
2	EMI Antenna	VULB 9163	483	SCHWARZBECK	1 year	2022-08-24
3	EMI Antenna	3115	00167250	ETS-Lindgren	1 year	2022-07-01
4	EMI Antenna	3116	2663	ETS-Lindgren	1 Year	2022-08-11

Note:

The test dates were before the calibration due dates of equipment used (the EMI Antenna which series number is 00167250)

8. Measurement Uncertainty

8.1 Transmitter Output Power

Measurement Uncertainty: 0.387dB, k=1.96

8.2 Peak Power Spectral Density

Measurement Uncertainty: 0.705dB, k=1.96

8.3 99% Occupied bandwidth

Measurement Uncertainty: 60.80Hz, k=1.96

8.4 Occupied Channel Bandwidth

Measurement Uncertainty: 60.80Hz, k=1.96

8.5 Band Edges Compliance

Measurement Uncertainty : 0.62dB,k=1.96

8.6 Spurious Emissions

Conducted (k=1.96)

Frequency Range	Uncertainty(dB)
$30\text{MHz} \leq f \leq 2\text{GHz}$	1.22
$2\text{GHz} \leq f \leq 3.6\text{GHz}$	1.22
$3.6\text{GHz} \leq f \leq 8\text{GHz}$	1.22
$8\text{GHz} \leq f \leq 12.75\text{GHz}$	1.51
$12.75\text{GHz} \leq f \leq 26\text{GHz}$	1.51
$26\text{GHz} \leq f \leq 40\text{GHz}$	1.59

Radiated (k=2)

Frequency Range	Uncertainty(dB)
9kHz-30MHz	4.92
$30\text{MHz} \leq f \leq 1\text{GHz}$	5.15
$1\text{GHz} \leq f \leq 18\text{GHz}$	5.54
$18\text{GHz} \leq f \leq 40\text{GHz}$	5.26

8.7 AC Power-line Conducted Emission

Measurement Uncertainty : 3.08dB,k=2

ANNEX A: MEASUREMENT RESULTS

A.1. Measurement Method

A.1.1. Conducted Measurements

- 1). Connect the EUT to the test system correctly.
- 2). Set the EUT to the required work mode.
- 3). Set the EUT to the required channel.
- 4). Set the spectrum analyzer to start measurement.
- 5). Record the values. Vector Signal Analyzer

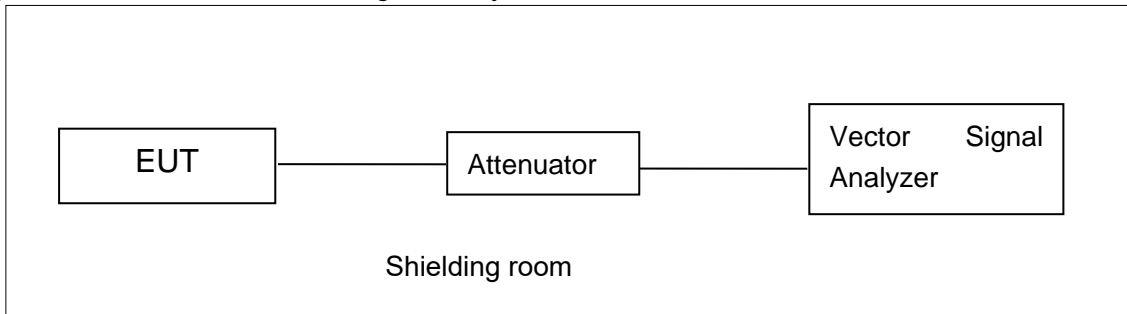

Test Setup for Maximum Output Power, Peak Power Spectral Density, Occupied 26dB Bandwidth, 99% Occupied bandwidth, In-Band Emissions

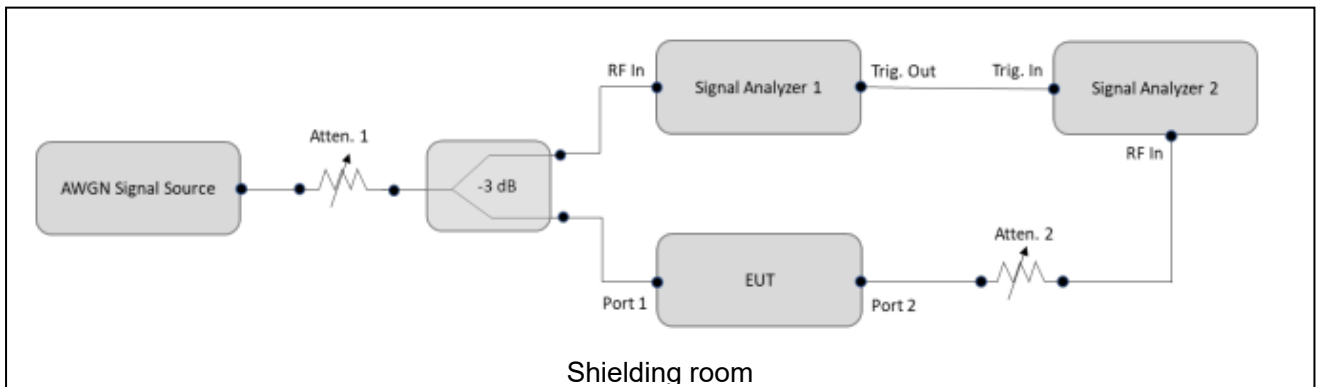

Test Setup for Contention Based Protocol

A.1.2. Radiated Emission Measurements

In the case of radiated emission, the used settings are as follows,

Sweep frequency from 30 MHz to 1GHz, RBW = 100 kHz, VBW = 300 kHz;

Sweep frequency from 1 GHz to 40GHz, RBW = 1MHz, VBW = 10Hz;

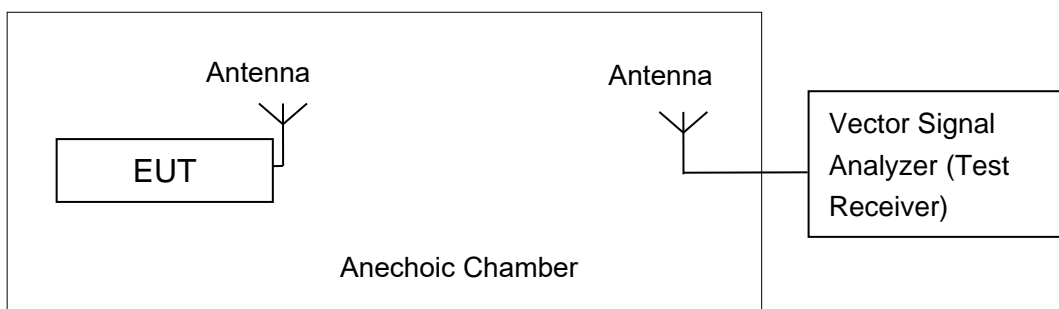



The measurement is made according to ANSI C63.10.

The radiated emission test is performed in semi-anechoic chamber. The distance from the EUT to the reference point of measurement antenna is 3m. The test is carried out on both vertical and horizontal polarization and only maximization result of both polarizations is kept. During the test, the turntable is rotated 360° and the measurement antenna is moved from 1m to 4m to get the maximization result. This maximization process was repeated with the EUT positioned in each of its three orthogonal orientations.

A.2. Maximum output Power

Measurement Limit and Method:

Standard	Frequency (MHz)	e.i.r.p Limit (dBm)
FCC CRF Part 15.407(a)	5925MHz~6425MHz	24dBm
	6425MHz~6525MHz	24dBm
	6525MHz~6875MHz	24dBm
	6875MHz~7125MHz	24dBm

The measurement method SA-2 is made according to KDB 987594 and KDB 789033.

Antenna Gain

BW	Frequency(MHz)	Ant4(dBi)	Ant5(dBi)	DG(dBi) Beamforming
20M	5955(1)	-2.5	-1.9	0.82
	6175(45)	-2.8	0	1.72
	6415(93)	-2.2	-1.9	0.96
	6435(97)	-2.2	-1.9	0.96
	6475(105)	-0.6	-1.2	2.12
	6515(113)	-0.5	-2.6	1.52
	6535(117)	-1.6	-1.5	1.46
	6695(149)	-1.8	-1.8	1.21
	6855(181)	-2.1	-2.3	0.81
	6875(185)	-0.5	-1.1	2.22
	6895(189)	-0.5	-1.1	2.22
	6995(209)	-2.4	-2.7	0.46
	7115(233)	-2.5	-1.5	1.02
40M	5965(3)	-2	-2.2	0.91
	6165(43)	-2.8	0	1.72
	640(91)	-2.5	-0.7	1.46
	6445(99)	-2.2	-1.9	0.96
	6485(107)	-0.6	-1.2	2.12

	6525(115)	-0.5	-2.6	1.52
	6565(123)	-1.6	-1.5	1.46
	6685(147)	-1.8	-1.8	1.21
	6845(179)	-2.1	-2.3	0.81
	6885(187)	-0.5	-1.1	2.22
	6925(195)	-1.4	-2.1	1.27
	6965(203)	-2.1	-2.1	0.91
	7085(227)	-2.2	0.6	2.32
80M	5985(7)	-2	-2.2	0.91
	6145(39)	-2.6	0.2	1.92
	6385(87)	-2.3	-0.7	1.55
	6465(103)	-2.1	-2.2	0.86
	6545(119)	-2.3	-3	0.37
	6625(135)	-3.2	-3.2	-0.19
	6705(151)	-1.8	-1.8	1.21
	6785(167)	-1.7	-1.8	1.26
	6865(183)	-0.5	-1.1	2.22
	6945(199)	-1.4	-2.1	1.27
	7025(215)	-2.5	-1.5	1.02
160M	6025(15)	-1.1	-0.8	2.06
	6185(47)	-3.4	-0.3	1.30
	6345(79)	-2.8	-0.1	1.66
	6505(111)	-0.6	-1.2	2.12
	6665(143)	-2.3	-2.4	0.66
	6825(175)	-2.2	-2.2	0.81
	6985(207)	-2.1	-2.1	0.91

For BF transmissions, power and PSD directional gain is calculated as:

Directional gain = $10 \log [(10G1 / 20 + 10G2 / 20 + \dots + 10Gn / 20) 2 / \text{NANT}]$ dBi, as following table for PSD. NANT = number of transmit antennas NSS = number of spatial streams. (The worst case

directional gain will occur when NSS = 1)

Measurement Results:

SISO

802.11a mode

Frequency	Test Result (dBm)			
	Data Rate			
	802.11a 6Mbps			
	Ant4 Conducted	Ant4 e.i.r.p	Ant5 Conducted	Ant5 e.i.r.p
5955MHz (Ch1)	2.68	0.18	1.78	-0.12
6175MHz (Ch45)	2.10	-0.70	2.73	2.73
6415MHz (Ch93)	2.03	-0.17	2.63	0.73
6435MHz (Ch97)	3.42	1.22	4.71	2.81
6475MHz (Ch105)	2.25	1.65	2.53	1.33
6515MHz (Ch113)	2.03	1.53	2.41	-0.19
6535MHz (Ch117)	2.91	1.31	2.26	0.76
6695MHz (Ch149)	3.74	1.94	1.92	0.12
6855MHz (Ch181)	3.51	1.41	2.26	-0.04
6875MHz (Ch185)	3.27	2.77	1.88	0.78
6895MHz (ch189)	3.25	2.75	2.02	0.92
6995MHz (Ch209)	2.92	0.52	1.65	-1.05
7115MHz (Ch233)	2.64	0.14	1.93	0.43

The data rate 6Mbps is selected as worse condition, and the following cases are performed with this condition.

802.11ax HE20(full RU) mode

Frequency	Test Result (dBm)			
	Data Rate			
	802.11ax HE20 MCS0			
	Ant4 Conducted	Ant4 e.i.r.p	Ant5 Conducted	Ant5 e.i.r.p
5955MHz (Ch1)	7.33	4.83	6.26	4.36

6175MHz (Ch45)	7.15	4.35	6.91	6.91
6415MHz (Ch93)	7.00	4.80	6.98	5.08
6435MHz (Ch97)	9.11	6.91	8.78	6.88
6475MHz (Ch105)	7.13	6.53	6.78	5.58
6515MHz (Ch113)	6.82	6.32	6.79	4.19
6535MHz (Ch117)	7.38	5.78	6.52	5.02
6695MHz (Ch149)	7.93	6.13	6.56	4.76
6855MHz (Ch181)	7.73	5.63	5.95	3.65
6875MHz (Ch185)	7.50	7.00	5.88	4.78
6895MHz (ch189)	7.44	6.94	6.08	4.98
6995MHz (Ch209)	6.24	3.84	5.40	2.70
7115MHz (Ch233)	6.78	4.28	6.22	4.72

The data rate MCS0 is selected as worse condition, and the following cases are performed with this condition.

802.11ax-HE40(full RU) mode

Frequency	Test Result (dBm)			
	Data Rate			
	802.11ax HE40 MCS0			
	Ant4 Conducted	Ant4 e.i.r.p	Ant5 Conducted	Ant5 e.i.r.p
5965MHz (Ch3)	7.31	5.31	7.10	4.90
6165MHz (Ch43)	7.21	4.41	7.32	7.32
6405MHz (Ch91)	7.01	4.51	6.85	6.15
6445MHz (Ch99)	7.38	5.18	6.85	4.95
6485MHz (Ch107)	7.20	6.60	6.84	5.64
6525MHz (Ch115)	7.39	6.89	6.57	3.97
6565MHz (Ch123)	7.14	5.54	6.53	5.03
6685MHz (Ch147)	7.93	6.13	6.65	4.85
6845MHz (Ch179)	7.96	5.86	6.16	3.86

6885MHz (Ch187)	7.86	7.36	6.44	5.34
6925MHz (ch195)	7.32	5.92	6.40	4.30
6965MHz (Ch203)	6.62	4.52	5.74	3.64
7085MHz (Ch227)	7.21	5.01	6.42	7.02

The data rate MCS0 is selected as worse condition, and the following cases are performed with this condition.

802.11ax-HE80 (RU26 index0) mode

Frequency	Test Result (dBm)			
	Data Rate			
	802.11ax HE80 MCS0			
	Ant4 Conducted	Ant4 e.i.r.p	Ant5 Conducted	Ant5 e.i.r.p
5985MHz (Ch7)	-6.45	-8.45	-6.59	-8.79
6145MHz (Ch39)	-6.52	-9.12	-6.17	-5.97
6385MHz (Ch87)	-6.75	-9.05	-7.06	-7.76
6465MHz (Ch103)	-5.81	-7.91	-6.56	-8.76
6545MHz (Ch119)	-6.01	-8.31	-7.03	-10.03
6625MHz (Ch135)	-6.25	-9.45	-7.26	-10.46
6705MHz (Ch151)	-5.97	-7.77	-7.03	-8.83
6785MHz (Ch167)	-5.29	-6.99	-6.59	-8.39
6865MHz (Ch183)	-5.22	-5.72	-6.59	-7.69
6945MHz (Ch199)	-6.12	-7.52	-7.02	-9.12
7025MHz (Ch215)	-6.64	-9.14	-7.46	-8.96

The data rate MCS0 is selected as worse condition, and the following cases are performed with this condition.

802.11ax-HE80 (full RU) mode

Frequency	Test Result (dBm)			
	Data Rate			
	802.11ax HE80 MCS0			
	Ant4 Conducted	Ant4 e.i.r.p	Ant5 Conducted	Ant5 e.i.r.p
5985MHz (Ch7)	7.49	5.49	6.88	4.68
6145MHz (Ch39)	7.55	4.95	7.20	7.40
6385MHz (Ch87)	7.06	4.76	6.51	5.81
6465MHz (Ch103)	7.25	5.15	6.73	4.53
6545MHz (Ch119)	7.36	5.06	6.56	3.56
6625MHz (Ch135)	7.44	4.24	6.38	3.18
6705MHz (Ch151)	7.58	5.78	6.39	4.59
6785MHz (Ch167)	7.98	6.28	6.30	4.50
6865MHz (Ch183)	7.97	7.47	6.22	5.12
6945MHz (Ch199)	6.88	5.48	6.05	3.95
7025MHz (Ch215)	6.41	3.91	5.72	4.22

The data rate MCS0 is selected as worse condition, and the following cases are performed with this condition.

802.11ax-HE160 (RU26 index0) mode

Frequency	Test Result (dBm)			
	Data Rate			
	802.11ax HE160 MCS0			
	Ant4 Conducted	Ant4 e.i.r.p	Ant5 Conducted	Ant5 e.i.r.p
6025MHz(Ch15)	-6.10	-7.20	-5.60	-6.40
6185MHz(Ch47)	-6.31	-9.71	-5.85	-6.15
6345MHz(Ch79)	-6.23	-9.03	-6.52	-6.62
6505MHz(Ch111)	-5.60	-6.20	-6.49	-7.69
6665MHz(Ch143)	-6.09	-8.39	-6.73	-9.13
6825MHz(Ch175)	-4.77	-6.97	-5.42	-7.62

6985MHz(Ch207)	-5.61	-7.71	-6.26	-8.36
----------------	-------	-------	-------	-------

The data rate MCS0 is selected as worse condition, and the following cases are performed with this condition.

802.11ax-HE160(full RU) mode

Frequency	Test Result (dBm)			
	Data Rate			
	802.11ax HE160 MCS0			
	Ant4 Conducted	Ant4 e.i.r.p	Ant5 Conducted	Ant5 e.i.r.p
6025MHz(Ch15)	8.08	6.98	8.79	7.99
6185MHz(Ch47)	8.03	4.63	8.22	7.92
6345MHz(Ch79)	7.71	4.91	7.11	7.01
6505MHz(Ch111)	8.00	7.40	7.09	5.89
6665MHz(Ch143)	7.88	5.58	7.06	4.66
6825MHz(Ch175)	8.77	6.57	6.96	4.76
6985MHz(Ch207)	7.26	5.16	6.55	4.45

The data rate MCS0 is selected as worse condition, and the following cases are performed with this condition.

MIMO

802.11a mode

Frequency	Test Result (dBm)			
	Data Rate			
	802.11a 6Mbps			
	Ant4	Ant5	Sum Conducted	Sum e.i.r.p
5955MHz (Ch1)	2.74	1.75	5.28	6.10
6175MHz (Ch45)	2.58	2.85	5.73	7.45
6415MHz (Ch93)	2.71	3.00	5.87	6.83
6435MHz (Ch97)	4.66	5.21	7.95	8.92
6475MHz (Ch105)	2.86	2.87	5.88	7.99
6515MHz (Ch113)	2.45	2.83	5.65	7.18

6535MHz (Ch117)	2.94	2.60	5.78	7.24
6695MHz (Ch149)	4.25	2.50	6.47	7.68
6855MHz (Ch181)	3.75	2.54	6.20	7.01
6875MHz (Ch185)	3.93	2.70	6.37	8.58
6895MHz (ch189)	3.72	2.41	6.12	8.34
6995MHz (Ch209)	2.74	1.61	5.22	5.68
7115MHz (Ch233)	2.64	2.36	5.51	6.54

The data rate 6Mbps is selected as worse condition, and the following cases are performed with this condition.

802.11ax HE20(full RU) mode

Frequency	Test Result (dBm)			
	Data Rate			
	802.11ax HE20 MCS0			
	Ant4	Ant5	Sum Conducted	Sum e.i.r.p
5955MHz (Ch1)	3.93	2.74	6.39	7.20
6175MHz (Ch45)	4.18	4.22	7.21	8.93
6415MHz (Ch93)	4.10	3.74	6.93	7.90
6435MHz (Ch97)	5.92	5.88	8.91	9.87
6475MHz (Ch105)	4.08	3.59	6.85	8.97
6515MHz (Ch113)	3.70	3.59	6.66	8.18
6535MHz (Ch117)	4.14	3.35	6.77	8.23
6695MHz (Ch149)	4.95	3.44	7.27	8.48
6855MHz (Ch181)	4.90	3.52	7.27	8.09
6875MHz (Ch185)	4.88	3.80	7.38	9.60
6895MHz (ch189)	4.60	3.67	7.17	9.39
6995MHz (Ch209)	3.90	3.10	6.53	6.99
7115MHz (Ch233)	4.05	3.32	6.71	7.74

The data rate MCS0 is selected as worse condition, and the following cases are performed with this condition.

802.11ax-HE40 (full RU) mode

Frequency	Test Result (dBm)			
	Data Rate			
	802.11ax HE40 MCS0			
	Ant4	Ant5	Sum Conducted	Sum e.i.r.p
5965MHz (Ch3)	7.04	6.72	9.89	10.80
6165MHz (Ch43)	7.05	7.26	10.17	11.89
6405MHz (Ch91)	6.99	6.63	9.82	11.28
6445MHz (Ch99)	7.21	6.66	9.95	10.92
6485MHz (Ch107)	7.06	6.62	9.86	11.97
6525MHz (Ch115)	7.18	6.40	9.82	11.34
6565MHz (Ch123)	7.06	6.39	9.75	11.21
6685MHz (Ch147)	7.95	6.54	10.31	11.52
6845MHz (Ch179)	7.96	6.65	10.36	11.18
6885MHz (Ch187)	7.87	6.99	10.46	12.68
6925MHz (ch195)	7.35	6.67	10.03	11.30
6965MHz (Ch203)	6.59	6.28	9.45	10.36
7085MHz (Ch227)	7.36	6.59	10.00	12.32

The data rate MCS0 is selected as worse condition, and the following cases are performed with this condition.

802.11ax-HE80 (RU26 index0) mode

Frequency	Test Result (dBm)			
	Data Rate			
	802.11ax HE80 MCS0			
	Ant4	Ant5	Sum Conducted	Sum e.i.r.p
5985MHz (Ch7)	-6.51	-7.01	-3.74	-2.83
6145MHz (Ch39)	-6.37	-6.10	-3.22	-1.30
6385MHz (Ch87)	-6.53	-6.79	-3.65	-2.10
6465MHz (Ch103)	-5.67	-6.17	-2.90	-2.04

6545MHz (Ch119)	-5.94	-6.68	-3.28	-2.92
6625MHz (Ch135)	-6.40	-6.78	-3.58	-3.77
6705MHz (Ch151)	-5.76	-6.63	-3.16	-1.95
6785MHz (Ch167)	-5.39	-6.15	-2.74	-1.48
6865MHz (Ch183)	-5.07	-6.41	-2.68	-0.46
6945MHz (Ch199)	-6.05	-6.88	-3.43	-2.17
7025MHz (Ch215)	-6.44	-7.30	-3.84	-2.81

The data rate MCS0 is selected as worse condition, and the following cases are performed with this condition.

802.11ax-HE80 (full RU) mode

Frequency	Test Result (dBm)			
	Data Rate			
	802.11ax HE80 MCS0			
	Ant4	Ant5	Sum Conducted	Sum e.i.r.p
5985MHz (Ch7)	7.21	6.91	10.07	10.98
6145MHz (Ch39)	7.11	7.53	10.34	12.26
6385MHz (Ch87)	6.92	6.54	9.74	11.29
6465MHz (Ch103)	7.05	6.77	9.92	10.78
6545MHz (Ch119)	7.07	6.53	9.82	10.19
6625MHz (Ch135)	7.36	6.41	9.92	9.73
6705MHz (Ch151)	7.59	6.44	10.06	11.27
6785MHz (Ch167)	7.92	6.30	10.20	11.46
6865MHz (Ch183)	8.18	6.39	10.39	12.60
6945MHz (Ch199)	6.87	6.05	9.49	10.76
7025MHz (Ch215)	7.04	5.80	9.47	10.50

The data rate MCS0 is selected as worse condition, and the following cases are performed with this condition.

802.11ax-HE160 (RU26 index0) mode

Frequency	Test Result (dBm)			
	Data Rate			
	802.11ax HE160 MCS0			
	Ant4	Ant5	Sum Conducted	Sum e.i.r.p
6025MHz (Ch15)	-6.38	-5.82	-3.08	-1.02
6185MHz (Ch47)	-6.27	-5.82	-3.03	-1.73
6345MHz (Ch79)	-6.11	-6.43	-3.26	-1.59
6505MHz (Ch111)	-5.17	-6.09	-2.60	-0.48
6665MHz (Ch143)	-5.79	-6.39	-3.07	-2.41
6825MHz (Ch175)	-4.29	-5.14	-1.68	-0.87
6985MHz (Ch207)	-5.52	-6.29	-2.88	-1.97

The data rate MCS0 is selected as worse condition, and the following cases are performed with this condition.

802.11ax-HE160 (full RU) mode

Frequency	Test Result (dBm)			
	Data Rate			
	802.11ax HE160 MCS0			
	Ant4	Ant5	Sum Conducted	Sum e.i.r.p
6025MHz (Ch15)	7.76	8.70	11.27	13.33
6185MHz (Ch47)	7.58	8.06	10.84	12.13
6345MHz (Ch79)	7.57	7.01	10.31	11.97
6505MHz (Ch111)	7.77	7.04	10.43	12.55
6665MHz (Ch143)	7.75	6.99	10.40	11.06
6825MHz (Ch175)	8.90	7.21	11.15	11.96
6985MHz (Ch207)	7.72	6.51	10.17	11.08

The data rate MCS0 is selected as worse condition, and the following cases are performed with this condition.

802.11a-5955MHz-mimo ant4:

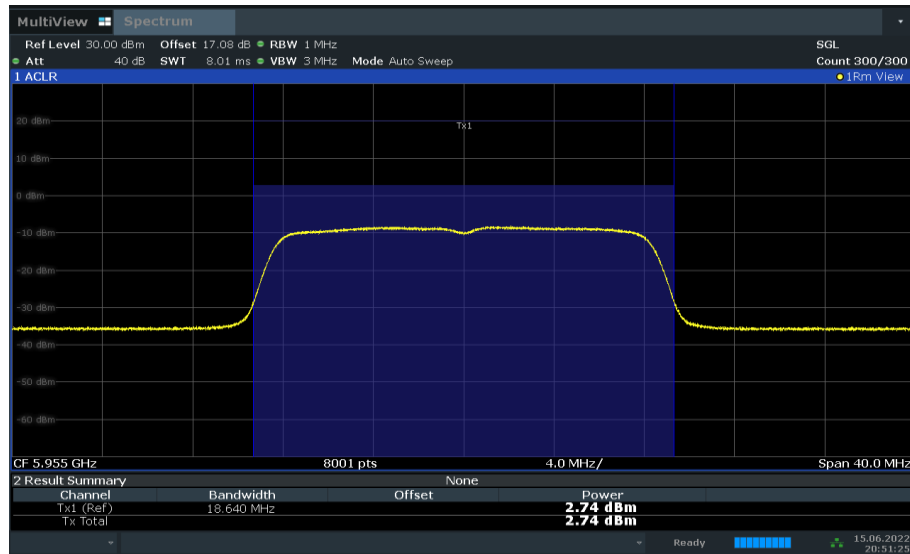

20:51:26 15.06.2022

Duty Cycle

Mode	11a	11ax20	11ax40	11ax80	11ax160
Duty Cycle	99%	99%	99%	97%	97%

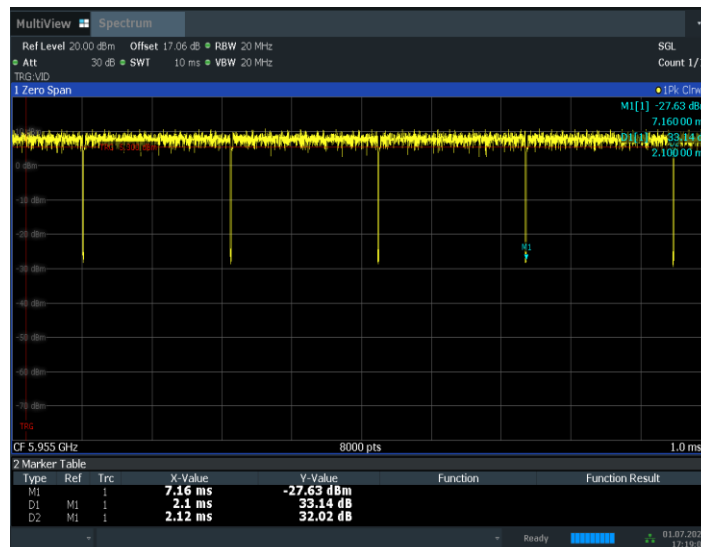

17:19:08 01.07.2022

Note: The following cases are performed with this condition:

- a) 802.11a (Ant4) mode is selected as the worst condition (SISO);
- 802.11ax160 (full RU) mode (Ant5) are selected as the worst condition (SISO);
- 802.11ax20/40/80 (full RU) mode (Ant4) are selected as the worst condition (SISO);
- b) 802.11a mode (Ant5) is selected as the worst condition (MIMO);

802.11ax20/40/80/160 (full RU) mode (Ant4) are selected as the worst condition (MIMO);

c) After evaluation, the maximum PSD of 802.11ax20/40 is in full RU, so all testing done under full RU. The maximum PSD of 802.11ax80/160 is in RU26 index0, so both of full RU and RU26 index0 are tested.

Conclusion: PASS

A.3. Peak Power Spectral Density (conducted)

Measurement Limit and Method:

Standard	Frequency (MHz)	e.i.r.p Limit (dBm/MHz)
FCC CRF Part 15.407(a)	5925MHz~6425MHz	-1
	6425MHz~6525MHz	-1
	6525MHz~6875MHz	-1
	6875MHz~7125MHz	-1

The output power measurement method Section F is made according to KDB 987594 and KDB 789033.

Measurement Results:

Ant4

Mode	Frequency	Power Spectral Density (dBm/MHz)		
		Conducted	e.i.r.p	Conclusion
802.11a	5955MHz (Ch1)	-8.77	-11.27	P
	6175MHz (Ch45)	-9.13	-11.93	P
	6415MHz (Ch93)	-8.85	-11.05	P
	6435MHz (Ch97)	-6.74	-8.94	P
	6475MHz (Ch105)	-8.53	-9.13	P
	6515MHz (Ch113)	-8.95	-9.45	P
	6535MHz (Ch117)	-8.39	-9.99	P
	6695MHz (Ch149)	-7.67	-9.47	P
	6855MHz (Ch181)	-8.02	-10.12	P
	6875MHz (Ch185)	-7.88	-8.38	P
	6895MHz (ch189)	-7.99	-8.49	P
	6995MHz (Ch209)	-8.95	-11.35	P
7115MHz (Ch233)	-8.90	-11.40	P	
802.11ax HE20 (full RU)	5955MHz (Ch1)	-3.65	-6.15	P
	6175MHz (Ch45)	-4.00	-6.80	P
	6415MHz (Ch93)	-4.90	-7.10	P
	6435MHz (Ch97)	-2.86	-5.06	P

	6475MHz (Ch105)	-4.86	-5.46	P
	6515MHz (Ch113)	-5.26	-5.76	P
	6535MHz (Ch117)	-4.69	-6.29	P
	6695MHz (Ch149)	-4.24	-6.04	P
	6855MHz (Ch181)	-4.42	-6.52	P
	6875MHz (Ch185)	-4.50	-5.00	P
	6895MHz (ch189)	-4.54	-5.04	P
	6995MHz (Ch209)	-5.88	-8.28	P
	7115MHz (Ch233)	-5.28	-7.78	P
802.11ax HE40 (full RU)	5965MHz (Ch3)	-7.77	-9.77	P
	6165MHz (Ch43)	-7.86	-10.66	P
	6405MHz (Ch91)	-8.18	-10.68	P
	6445MHz (Ch99)	-7.61	-9.81	P
	6485MHz (Ch107)	-7.92	-8.52	P
	6525MHz (Ch115)	-7.83	-8.33	P
	6565MHz (Ch123)	-7.98	-9.58	P
	6685MHz (Ch147)	-7.33	-9.13	P
	6845MHz (Ch179)	-7.16	-9.26	P
	6885MHz (Ch187)	-7.25	-7.75	P
	6925MHz (ch195)	-7.65	-9.05	P
	6965MHz (Ch203)	-8.50	-10.60	P
	7085MHz (Ch227)	-7.89	-10.09	P
802.11ax HE80 (RU26 index0)	5985MHz (Ch7)	-9.59	-11.59	P
	6145MHz(Ch39)	-9.66	-12.26	P
	6385MHz (Ch87)	-10.35	-12.65	P
	6465MHz (Ch103)	-9.26	-11.36	P
	6545MHz (Ch119)	-9.40	-11.70	P
	6625MHz (Ch135)	-9.65	-12.85	P
	6705MHz (Ch151)	-9.37	-11.17	P
	6785MHz (Ch167)	-8.75	-10.45	P
	6865MHz (Ch183)	-8.83	-9.33	P
	6945MHz (Ch199)	-9.83	-11.23	P
	7025MHz (Ch215)	-10.36	-12.86	P
802.11ax HE80 (full RU)	5985MHz (Ch7)	-10.78	-12.78	P
	6145MHz(Ch39)	-10.83	-13.43	P
	6385MHz (Ch87)	-10.88	-13.18	P
	6465MHz (Ch103)	-10.85	-12.95	P
	6545MHz (Ch119)	-10.84	-13.14	P
	6625MHz (Ch135)	-10.81	-14.01	P
	6705MHz (Ch151)	-10.52	-12.32	P
	6785MHz (Ch167)	-10.01	-11.71	P
	6865MHz (Ch183)	-10.19	-10.69	P

	6945MHz (Ch199)	-11.09	-12.49	P
	7025MHz (Ch215)	-11.84	-14.34	P
802.11ax HE160 (RU26 index0)	6025MHz (Ch15)	-10.38	-11.48	P
	6185MHz (Ch47)	-9.93	-13.33	P
	6345MHz (Ch79)	-10.20	-13.00	P
	6505MHz (Ch111)	-9.03	-9.63	P
	6665MHz (Ch143)	-10.08	-12.38	P
	6825MHz (Ch175)	-7.75	-9.95	P
	6985MHz (Ch207)	-9.67	-11.77	P
802.11ax HE160 (full RU)	6025MHz (Ch15)	-12.41	-13.21	P
	6185MHz (Ch47)	-13.08	-13.38	P
	6345MHz (Ch79)	-14.26	-14.36	P
	6505MHz (Ch111)	-14.24	-15.44	P
	6665MHz (Ch143)	-14.34	-16.74	P
	6825MHz (Ch175)	-13.98	-16.18	P
	6985MHz (Ch207)	-14.74	-16.84	P

MIMO

Mode	Frequency	Power Spectral Density (dBm/MHz)				Conclusion
		Ant4	Ant5	Sum Conducted	Sum e.i.r.p	
802.11a	5955MHz (Ch1)	-8.57	-9.52	-6.01	-5.19	P
	6175MHz (Ch45)	-8.73	-8.52	-5.61	-3.89	P
	6415MHz (Ch93)	-8.71	-8.09	-5.38	-4.42	P
	6435MHz (Ch97)	-6.77	-5.90	-3.30	-2.34	P
	6475MHz (Ch105)	-8.56	-8.17	-5.35	-3.23	P
	6515MHz (Ch113)	-8.89	-8.20	-5.52	-4.00	P
	6535MHz (Ch117)	-7.95	-8.44	-5.18	-3.72	P
	6695MHz (Ch149)	-7.16	-8.39	-4.72	-3.51	P
	6855MHz (Ch181)	-7.68	-8.28	-4.96	-4.15	P
	6875MHz (Ch185)	-7.59	-8.19	-4.87	-2.65	P
	6895MHz (ch189)	-7.73	-8.44	-5.06	-2.84	P
6995MHz (Ch209)	-8.61	-9.24	-5.90	-5.44	P	
7115MHz (Ch233)	-8.65	-8.40	-5.51	-4.49	P	
802.11ax HE20 (full RU)	5955MHz (Ch1)	-8.25	-9.33	-5.75	-4.93	P
	6175MHz (Ch45)	-8.06	-7.94	-4.99	-3.27	P
	6415MHz (Ch93)	-8.12	-8.18	-5.14	-4.18	P
	6435MHz (Ch97)	-6.22	-5.97	-3.08	-2.12	P
	6475MHz (Ch105)	-8.12	-8.34	-5.22	-3.10	P
	6515MHz (Ch113)	-8.58	-8.34	-5.45	-3.92	P
	6535MHz (Ch117)	-8.14	-8.52	-5.32	-3.86	P
6695MHz (Ch149)	-7.41	-8.25	-4.80	-3.59	P	

	6855MHz (Ch181)	-7.48	-8.15	-4.79	-3.98	P
	6875MHz (Ch185)	-7.66	-8.01	-4.82	-2.61	P
	6895MHz (ch189)	-7.74	-7.90	-4.81	-2.59	P
	6995MHz (Ch209)	-8.40	-8.55	-5.46	-5.00	P
	7115MHz (Ch233)	-8.23	-8.31	-5.26	-4.23	P
802.11ax HE40 (full RU)	5965MHz (Ch3)	-8.13	-8.15	-5.13	-4.22	P
	6165MHz (Ch43)	-8.03	-7.63	-4.82	-3.09	P
	6405MHz (Ch91)	-8.17	-8.28	-5.21	-3.76	P
	6445MHz (Ch99)	-7.64	-8.10	-4.85	-3.89	P
	6485MHz (Ch107)	-7.99	-8.22	-5.09	-2.98	P
	6525MHz (Ch115)	-8.01	-8.41	-5.20	-3.67	P
	6565MHz (Ch123)	-7.88	-8.40	-5.12	-3.66	P
	6685MHz (Ch147)	-7.15	-8.16	-4.62	-3.41	P
	6845MHz (Ch179)	-7.01	-7.98	-4.46	-3.65	P
	6885MHz (Ch187)	-7.20	-7.61	-4.39	-2.17	P
	6925MHz (ch195)	-7.73	-7.84	-4.77	-3.51	P
	6965MHz (Ch203)	-8.39	-8.27	-5.32	-4.41	P
7085MHz (Ch227)	-7.67	-8.03	-4.84	-2.51	P	
802.11ax HE80 (RU26 index0)	5985MHz (Ch7)	-9.80	-10.46	-7.11	-6.20	P
	6145MHz(Ch39)	-9.67	-9.37	-6.51	-4.58	P
	6385MHz (Ch87)	-10.06	-10.33	-7.18	-5.64	P
	6465MHz (Ch103)	-9.09	-9.65	-6.35	-5.49	P
	6545MHz (Ch119)	-9.37	-10.15	-6.73	-6.36	P
	6625MHz (Ch135)	-9.87	-10.27	-7.06	-7.24	P
	6705MHz (Ch151)	-9.14	-10.10	-6.58	-5.37	P
	6785MHz (Ch167)	-8.75	-9.68	-6.18	-4.92	P
	6865MHz (Ch183)	-8.67	-10.28	-6.39	-4.18	P
	6945MHz (Ch199)	-9.89	-10.87	-7.34	-6.07	P
7025MHz (Ch215)	-10.39	-11.28	-7.80	-6.78	P	
802.11ax HE80 (full RU)	5985MHz (Ch7)	-11.11	-11.02	-8.05	-7.14	P
	6145MHz(Ch39)	-11.09	-10.49	-7.77	-5.85	P
	6385MHz (Ch87)	-11.07	-11.35	-8.20	-6.65	P
	6465MHz (Ch103)	-11.13	-11.25	-8.18	-7.32	P
	6545MHz (Ch119)	-11.17	-11.46	-8.30	-7.93	P
	6625MHz (Ch135)	-10.90	-11.41	-8.14	-8.33	P
	6705MHz (Ch151)	-10.53	-11.35	-7.91	-6.70	P
	6785MHz (Ch167)	-10.17	-11.21	-7.65	-6.39	P
	6865MHz (Ch183)	-10.09	-11.27	-7.63	-5.41	P
	6945MHz (Ch199)	-11.25	-11.33	-8.28	-7.01	P
7025MHz (Ch215)	-11.13	-11.76	-8.42	-7.40	P	
802.11ax HE160	6025MHz (Ch15)	-10.16	-9.42	-6.76	-4.70	P
	6185MHz (Ch47)	-9.84	-9.38	-6.59	-5.30	P

(RU26 index0)	6345MHz (Ch79)	-10.01	-10.39	-7.19	-5.52	P
	6505MHz (Ch111)	-8.96	-10.10	-6.48	-4.37	P
	6665MHz (Ch143)	-9.74	-10.41	-7.05	-6.39	P
	6825MHz (Ch175)	-8.20	-9.24	-5.68	-4.87	P
	6985MHz (Ch207)	-9.96	-11.04	-7.46	-6.55	P
802.11ax HE160 (full RU)	6025MHz (Ch15)	-13.43	-12.15	-9.73	-7.67	P
	6185MHz (Ch47)	-13.58	-12.81	-10.17	-8.87	P
	6345MHz (Ch79)	-13.52	-13.91	-10.70	-9.04	P
	6505MHz (Ch111)	-13.32	-13.82	-10.55	-8.44	P
	6665MHz (Ch143)	-13.25	-13.73	-10.47	-9.81	P
	6825MHz (Ch175)	-11.88	-13.05	-9.42	-8.61	P
	6985MHz (Ch207)	-13.10	-13.83	-10.44	-9.53	P

802.11a-5955MHz-mimo ant4:



Conclusion: PASS

A.4. Occupied 26dB Bandwidth(conducted)

Measurement Limit and Method:

Standard	Limit (kHz)
FCC 47 CFR Part 15.403 (i)	/

The measurement is made according to KDB 987594 and KDB 789033

Measurement Result:

Mode	Frequency	Occupied 26dB Bandwidth (MHz)		conclusion
		Fig.	Value	
802.11a	5955MHz (Ch1)	Fig.1	18.84	P
	6175MHz (Ch45)	Fig.2	18.76	P
	6415MHz (Ch93)	Fig.3	19.08	P
	6435MHz (Ch97)	Fig.4	18.76	P
	6475MHz (Ch105)	Fig.5	18.88	P
	6515MHz (Ch113)	Fig.6	18.84	P
	6535MHz (Ch117)	Fig.7	18.96	P
	6695MHz (Ch149)	Fig.8	18.84	P
	6855MHz (Ch181)	Fig.9	19.04	P
	6875MHz (Ch185)	Fig.10	18.84	P
	6895MHz (ch189)	Fig.11	19.12	P
	6995MHz (Ch209)	Fig.12	19.00	P
7115MHz (Ch233)	Fig.13	19.36	P	
802.11ax HE20 (full RU)	5955MHz (Ch1)	Fig.14	21.76	P
	6175MHz (Ch45)	Fig.15	22.08	P
	6415MHz (Ch93)	Fig.16	21.88	P
	6435MHz (Ch97)	Fig.17	21.88	P
	6475MHz (Ch105)	Fig.18	21.88	P
	6515MHz (Ch113)	Fig.19	21.92	P
	6535MHz (Ch117)	Fig.20	21.96	P
	6695MHz (Ch149)	Fig.21	22.04	P
	6855MHz (Ch181)	Fig.22	21.64	P
	6875MHz (Ch185)	Fig.23	21.84	P
	6895MHz (ch189)	Fig.24	21.96	P
	6995MHz (Ch209)	Fig.25	22.24	P
7115MHz (Ch233)	Fig.26	22.20	P	
802.11ax HE40 (full RU)	5965MHz (Ch3)	Fig.27	43.28	P
	6165MHz (Ch43)	Fig.28	43.36	P
	6405MHz (Ch91)	Fig.29	43.12	P
	6445MHz (Ch99)	Fig.30	43.68	P
	6485MHz (Ch107)	Fig.31	42.80	P
	6525MHz (Ch115)	Fig.32	43.36	P
	6565MHz (Ch123)	Fig.33	44.64	P

	6685MHz (Ch147)	Fig.34	43.28	P
	6845MHz (Ch179)	Fig.35	43.76	P
	6885MHz (Ch187)	Fig.36	43.12	P
	6925MHz (ch195)	Fig.37	43.12	P
	6965MHz (Ch203)	Fig.38	43.92	P
	7085MHz (Ch227)	Fig.39	43.12	P
802.11ax HE80 (full RU)	5985MHz (Ch7)	Fig.40	90.08	P
	6145MHz (Ch39)	Fig.41	88.32	P
	6385MHz (Ch87)	Fig.42	92.32	P
	6465MHz (Ch103)	Fig.43	90.24	P
	6545MHz (Ch119)	Fig.44	89.76	P
	6625MHz (Ch135)	Fig.45	89.60	P
	6705MHz (Ch151)	Fig.46	89.12	P
	6785MHz (Ch167)	Fig.47	92.00	P
	6865MHz (Ch183)	Fig.48	90.08	P
	6945MHz (Ch199)	Fig.49	89.60	P
	7025MHz (Ch215)	Fig.50	89.44	P
802.11ax HE160 (full RU)	6025MHz (Ch15)	Fig.51	172.80	P
	6185MHz (Ch47)	Fig.52	173.76	P
	6345MHz (Ch79)	Fig.53	173.76	P
	6505MHz (Ch111)	Fig.54	173.44	P
	6665MHz (Ch143)	Fig.55	174.40	P
	6825MHz (Ch175)	Fig.56	172.48	P
	6985MHz (Ch207)	Fig.57	231.36	P

Conclusion: PASS

Test graphs as below:

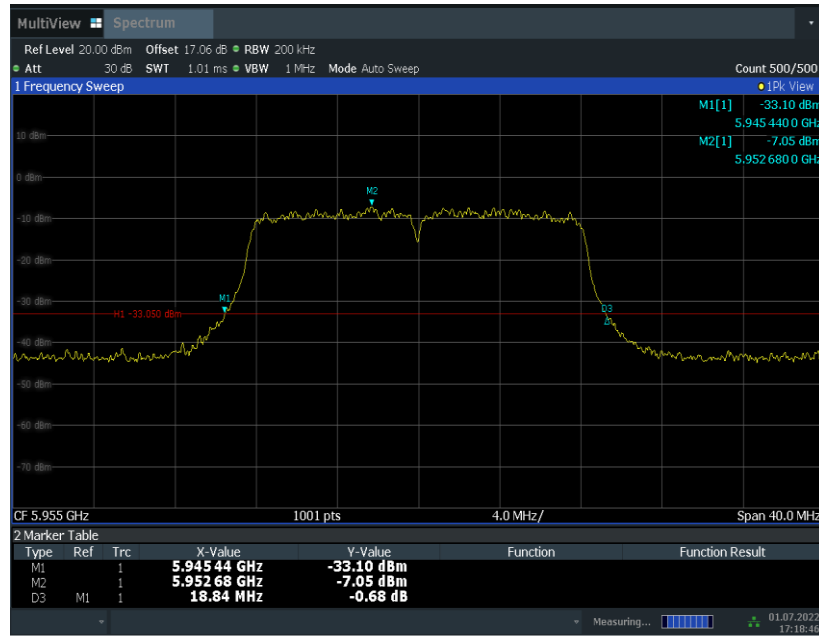

17:18:46 01.07.2022

Fig.1 Occupied 26dB Bandwidth (802.11a, 5955MHz)

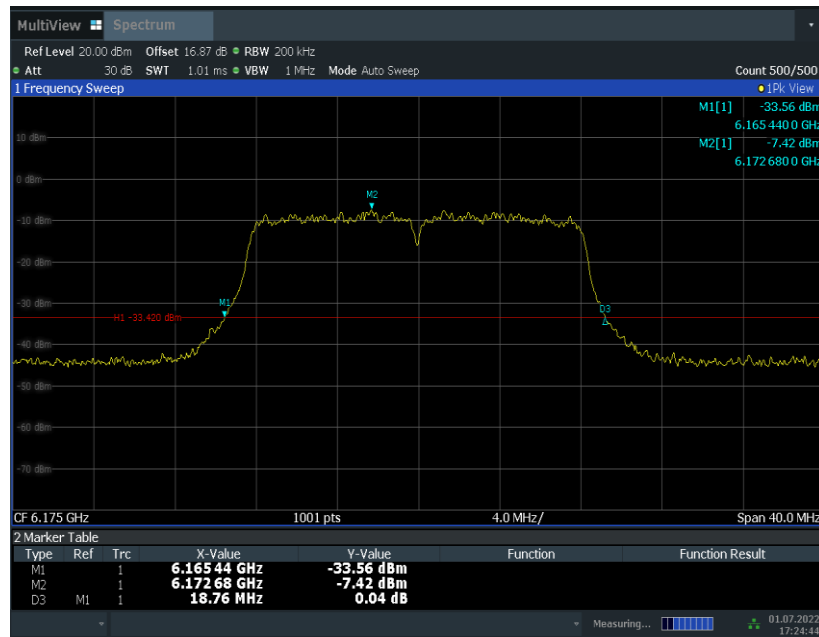

17:24:44 01.07.2022

Fig.2 Occupied 26dB Bandwidth (802.11a, 6175MHz)

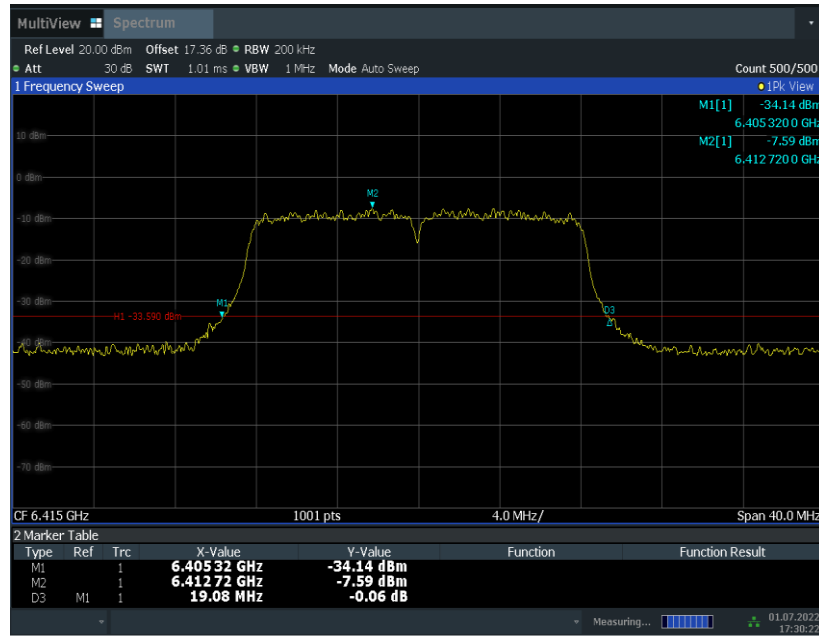

17:30:23 01.07.2022

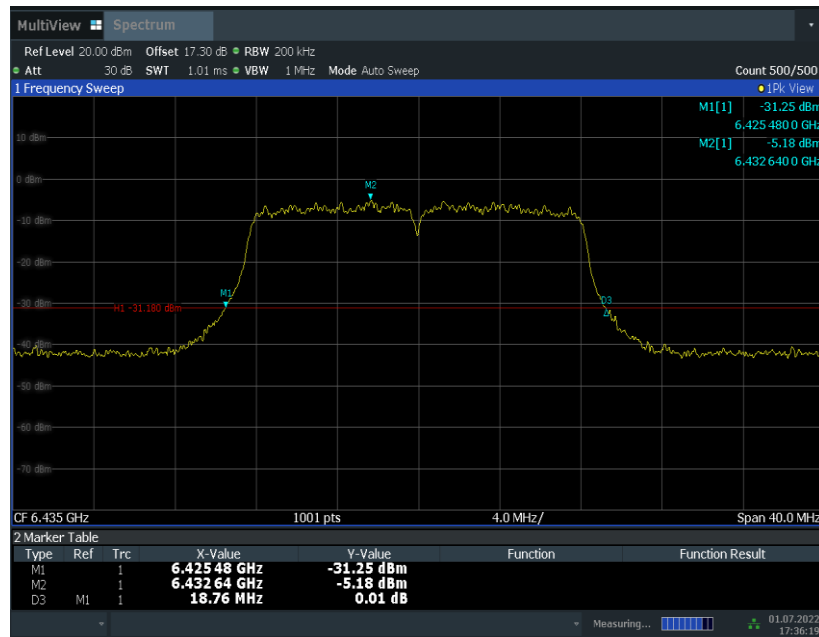
Fig.3 Occupied 26dB Bandwidth (802.11a, 6415MHz)

17:36:20 01.07.2022

Fig.4 Occupied 26dB Bandwidth (802.11a, 6435MHz)

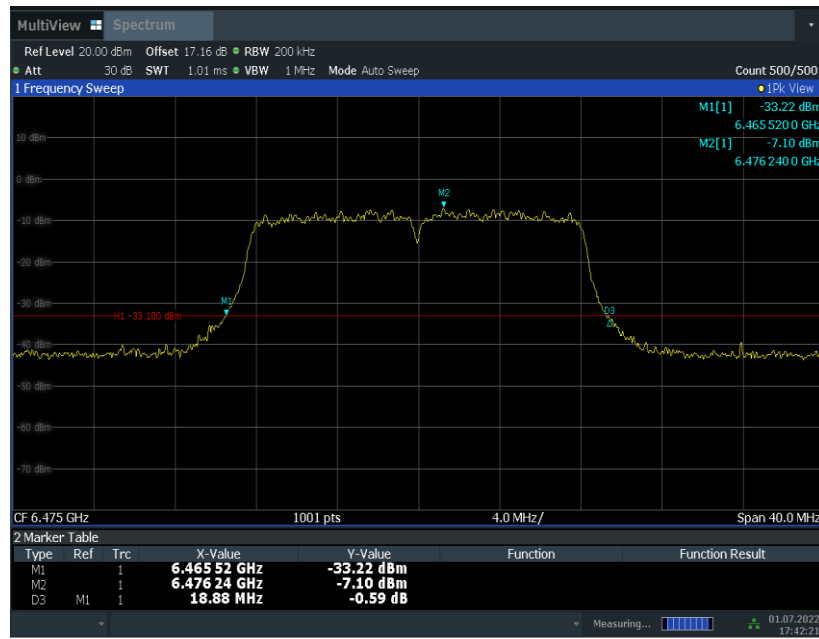

17:42:22 01.07.2022

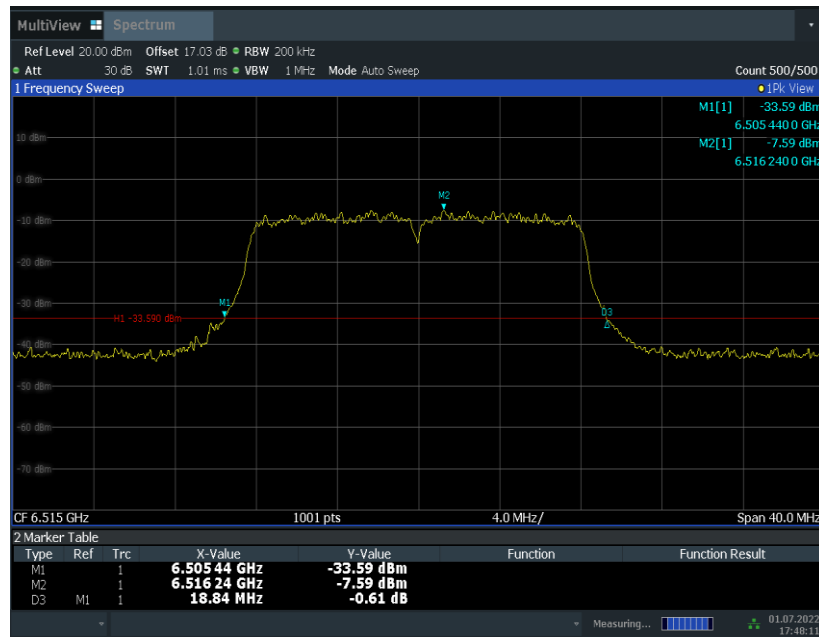
Fig.5 Occupied 26dB Bandwidth (802.11a, 6475MHz)

17:48:12 01.07.2022

Fig.6 Occupied 26dB Bandwidth (802.11a, 6515MHz)

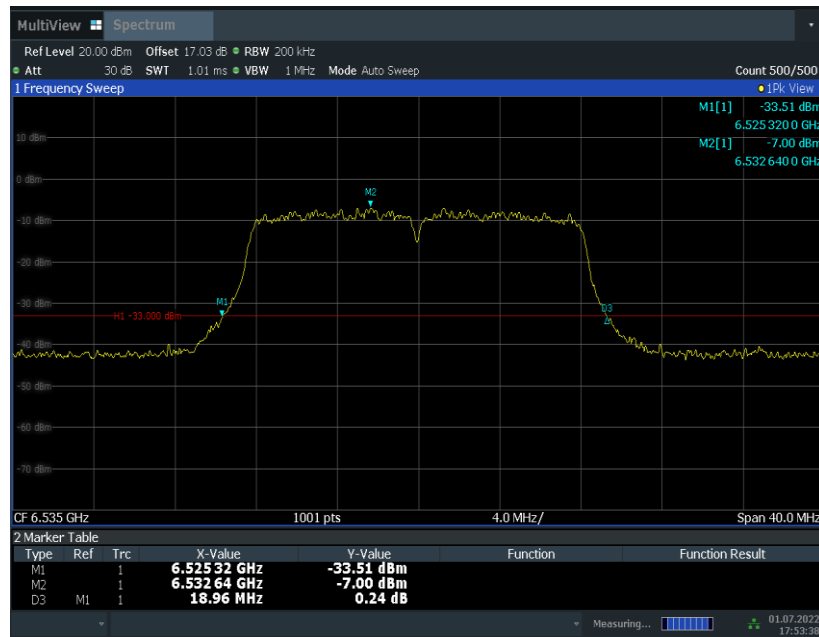

17:53:38 01.07.2022

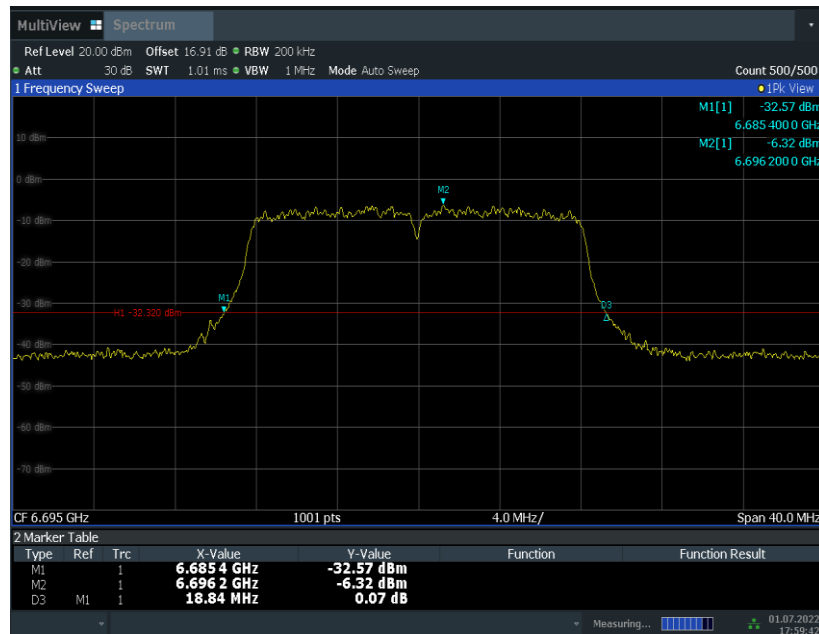
Fig.7 Occupied 26dB Bandwidth (802.11a, 6535MHz)

17:59:42 01.07.2022

Fig.8 Occupied 26dB Bandwidth (802.11a, 6695MHz)

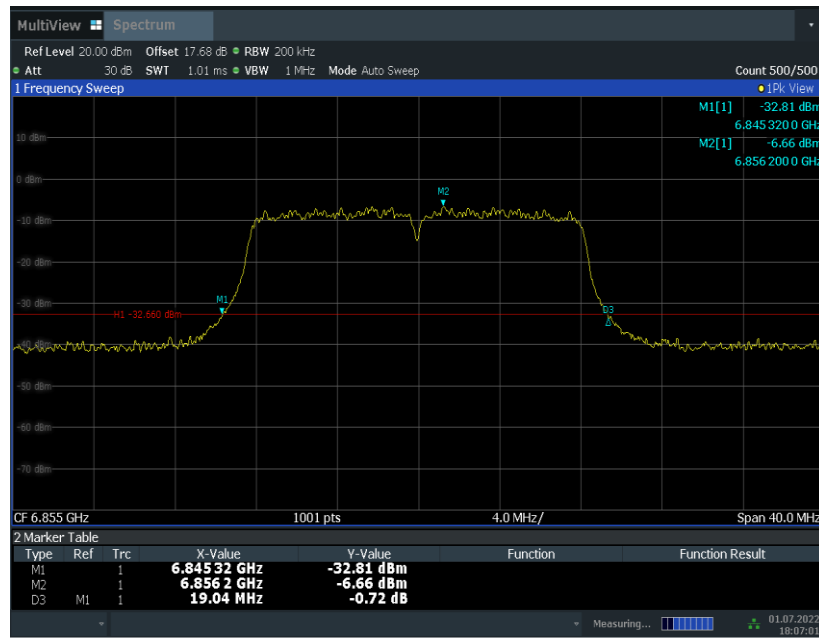

18:07:01 01.07.2022

Fig.9 Occupied 26dB Bandwidth (802.11a, 6855MHz)

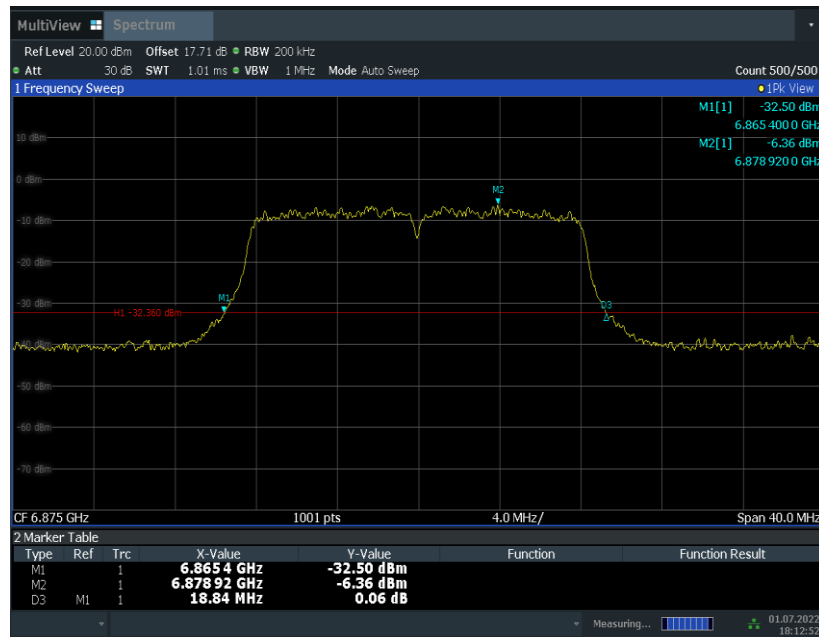

18:12:53 01.07.2022

Fig.10 Occupied 26dB Bandwidth (802.11a, 6875MHz)

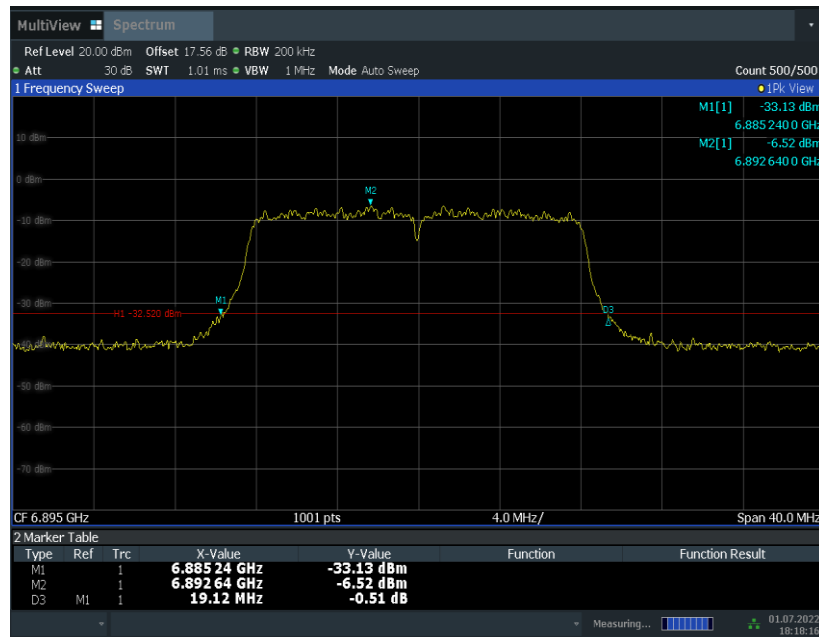

18:18:17 01.07.2022

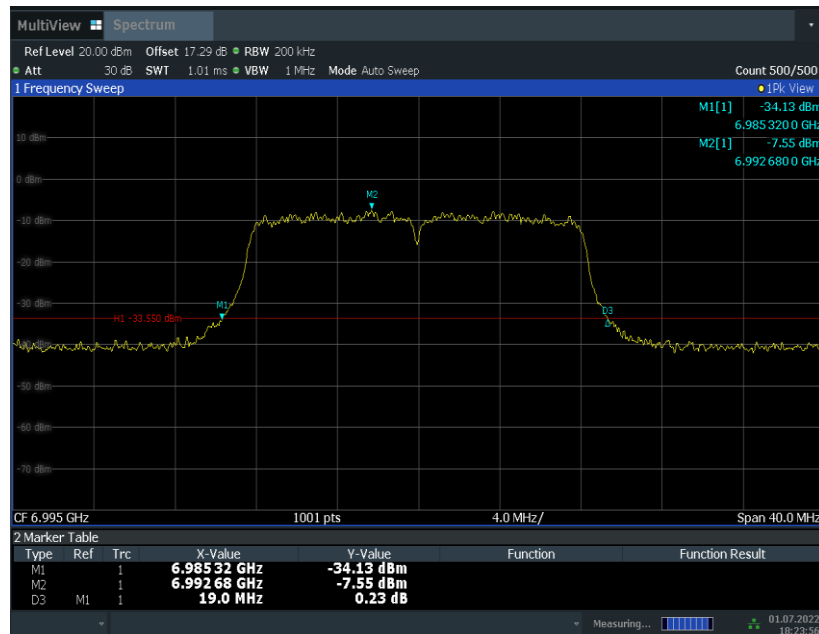
Fig.11 Occupied 26dB Bandwidth (802.11a, 6895MHz)

18:23:57 01.07.2022

Fig.12 Occupied 26dB Bandwidth (802.11a 6995MHz)

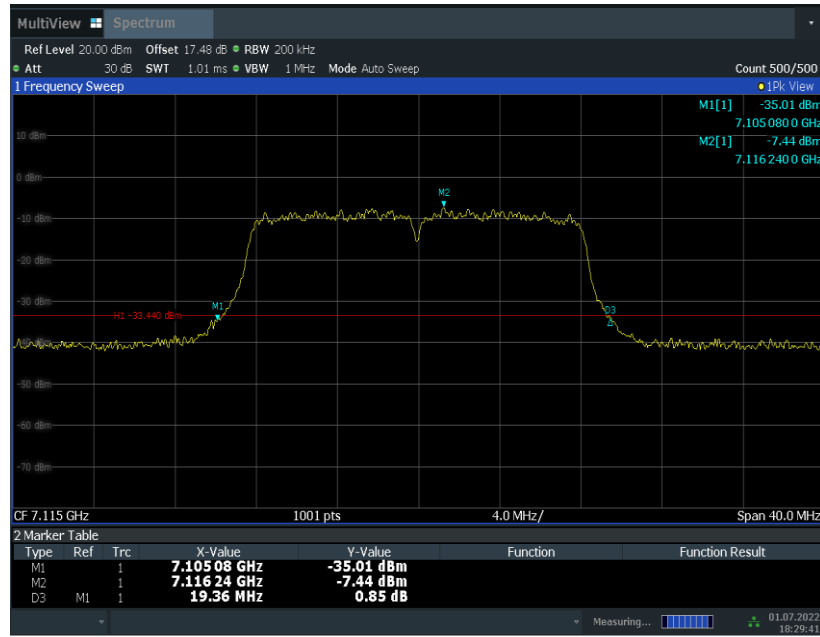

18:29:41 01.07.2022

Fig.13 Occupied 26dB Bandwidth (802.11a, 7115MHz)

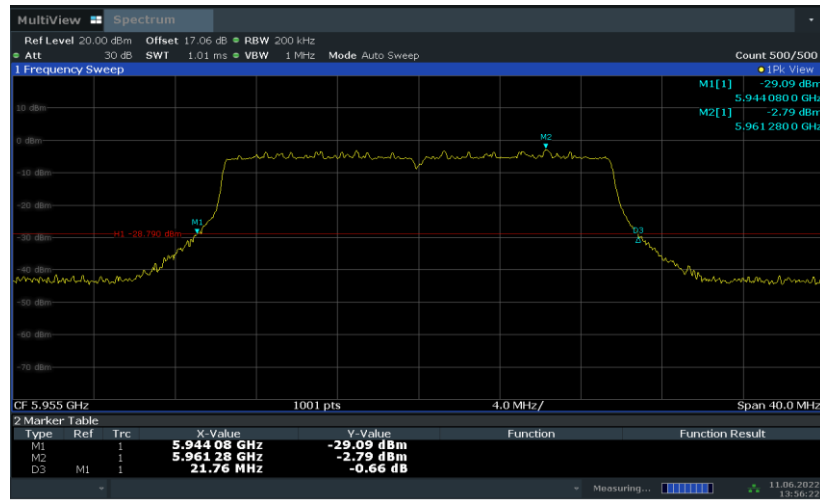

13:56:23 11.06.2022

Fig.14 Occupied 26dB Bandwidth (802.11ax-HE20, 5955MHz)

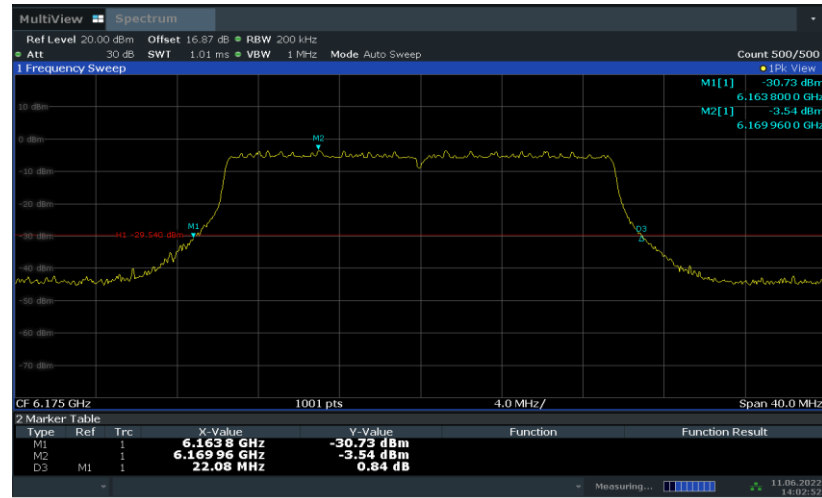

14:02:53 11.06.2022

Fig.15 Occupied 26dB Bandwidth (802.11ax-HE20, 6175MHz)

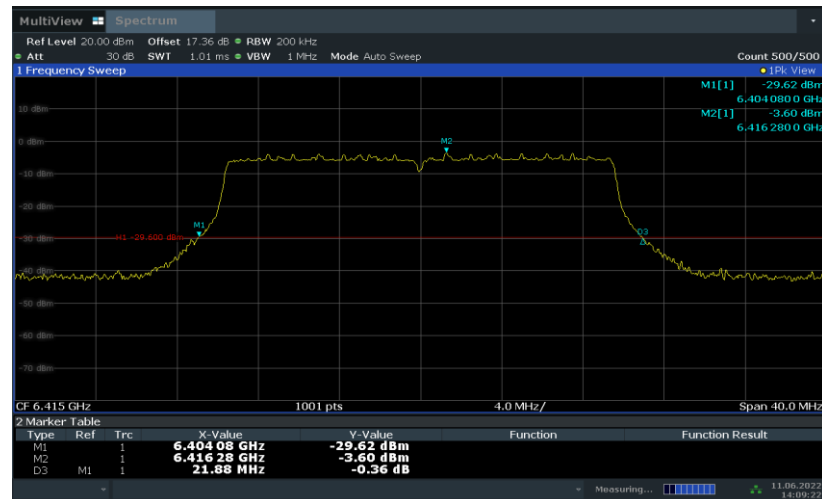

14:09:23 11.06.2022

Fig.16 Occupied 26dB Bandwidth (802.11ax-HE20, 6415MHz)

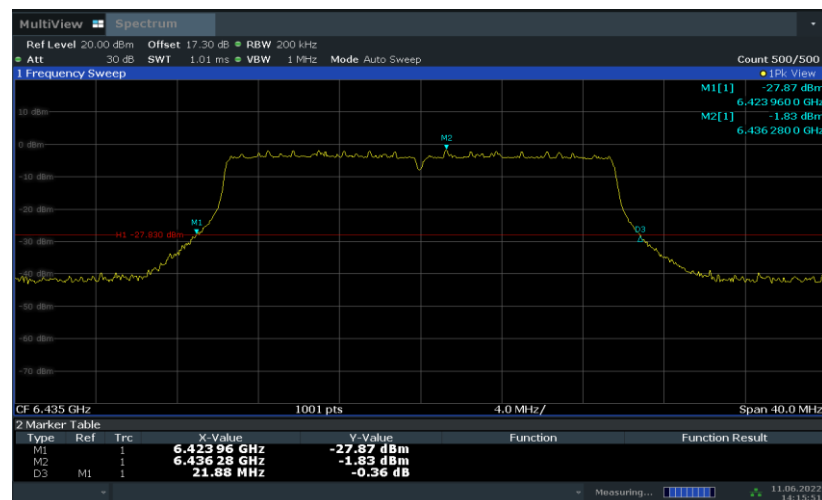

14:15:51 11.06.2022

Fig.17 Occupied 26dB Bandwidth (802.11ax-HE20, 6435MHz)

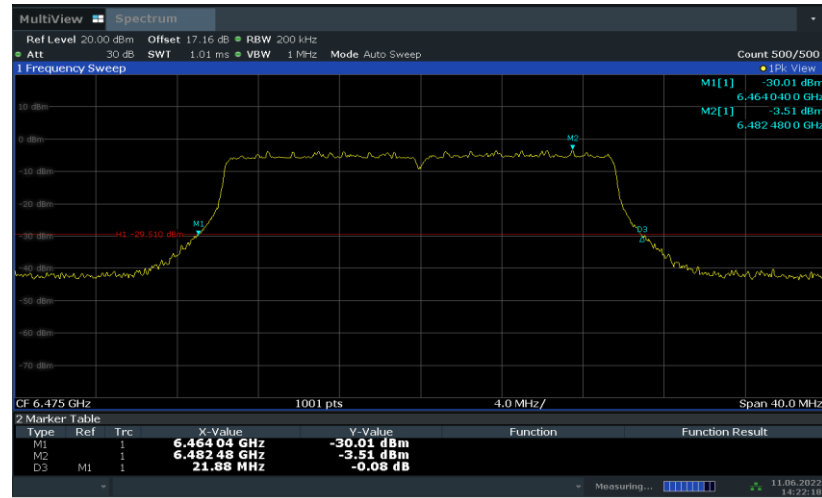

14:22:19 11.06.2022

Fig.18 Occupied 26dB Bandwidth (802.11ax-HE20, 6475MHz)

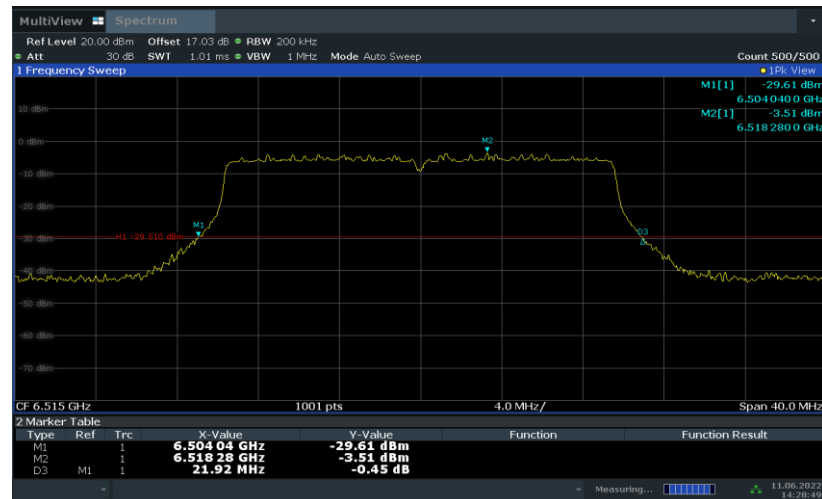

14:28:49 11.06.2022

Fig.19 Occupied 26dB Bandwidth (802.11ax-HE20, 6515MHz)

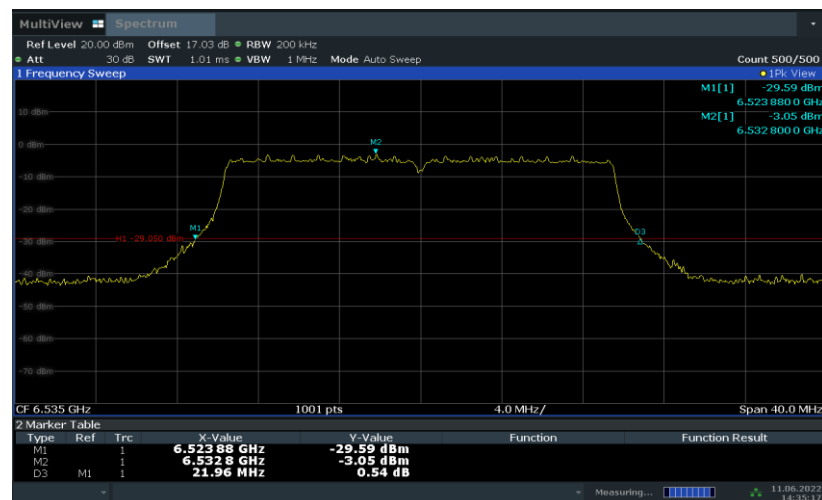

14:35:18 11.06.2022

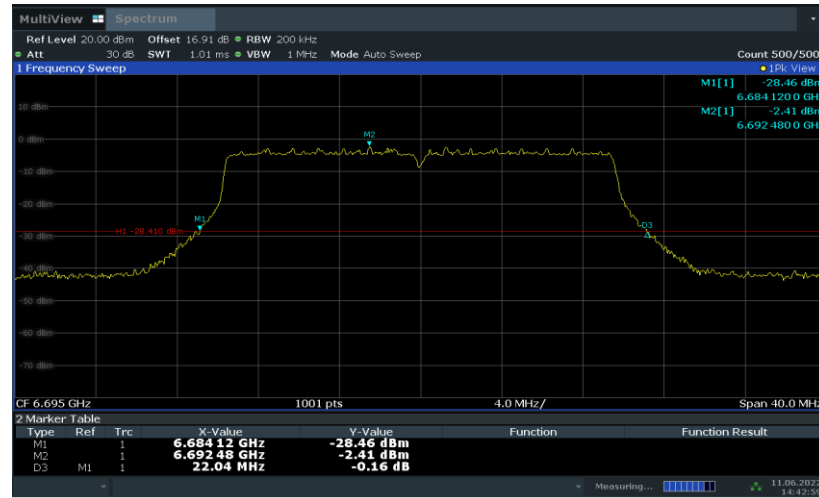
Fig.20 Occupied 26dB Bandwidth (802.11ax-HE20, 6535MHz)

14:43:00 11.06.2022

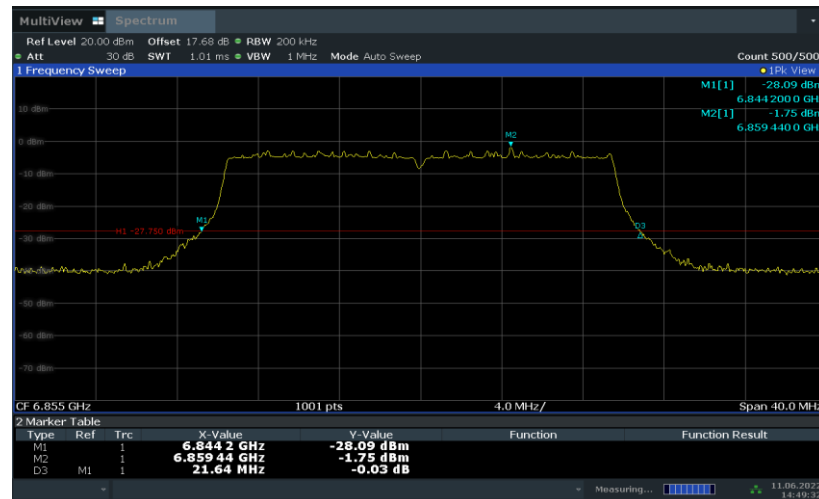
Fig.21 Occupied 26dB Bandwidth (802.11ax-HE20, 6695MHz)

14:49:32 11.06.2022

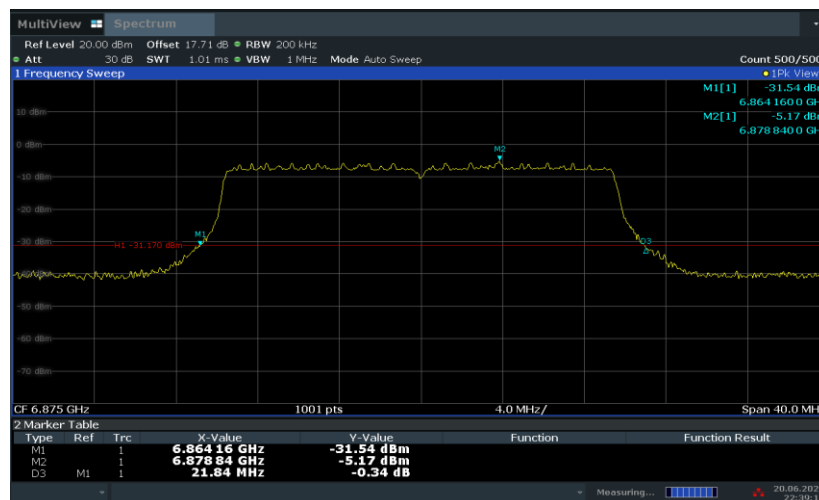
Fig.22 Occupied 26dB Bandwidth (802.11ax-HE20, 6855MHz)

22:39:15 20.06.2022

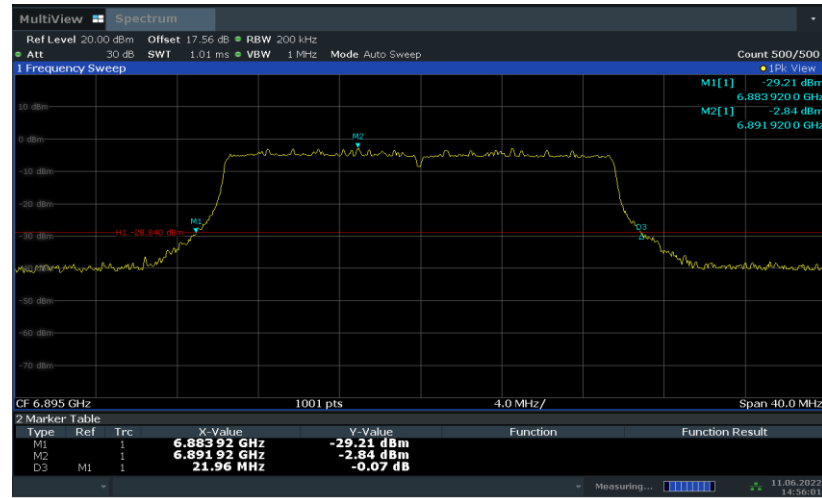
Fig.23 Occupied 26dB Bandwidth (802.11ax-HE20, 6875MHz)

14:56:02 11.06.2022

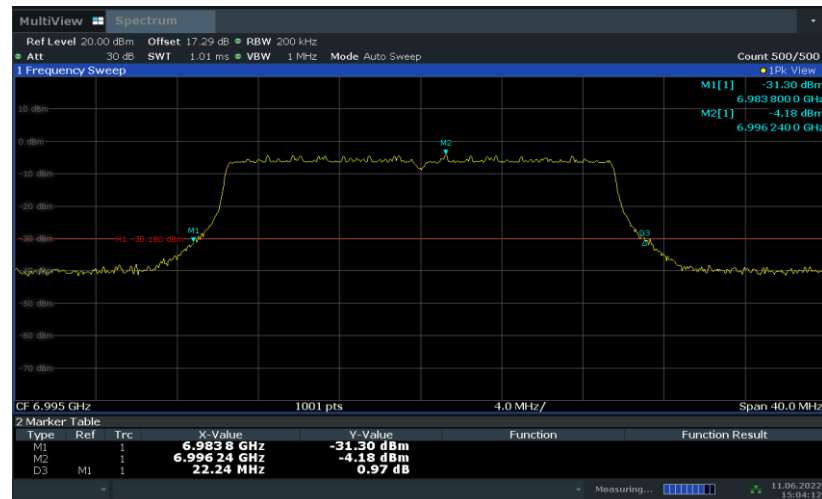
Fig.24 Occupied 26dB Bandwidth (802.11ax-HE20, 6895MHz)

15:04:13 11.06.2022

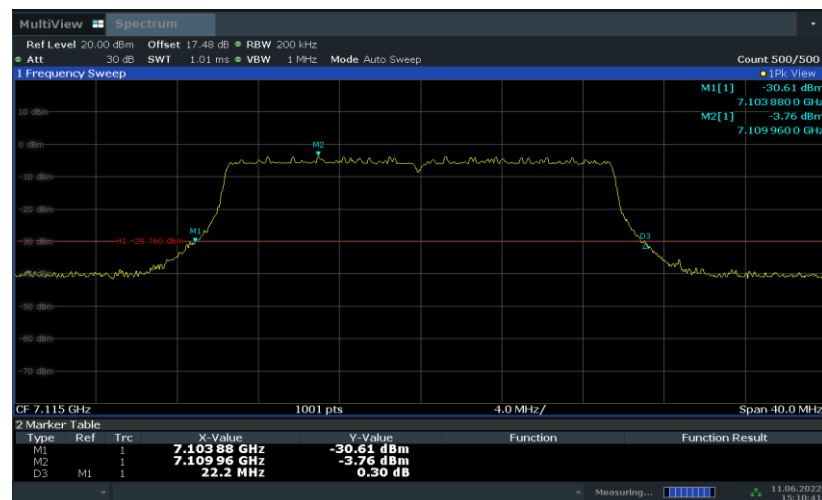
Fig.25 Occupied 26dB Bandwidth (802.11ax-HE20, 6995MHz)

15:10:41 11.06.2022

Fig.26 Occupied 26dB Bandwidth (802.11ax-HE20, 7115MHz)

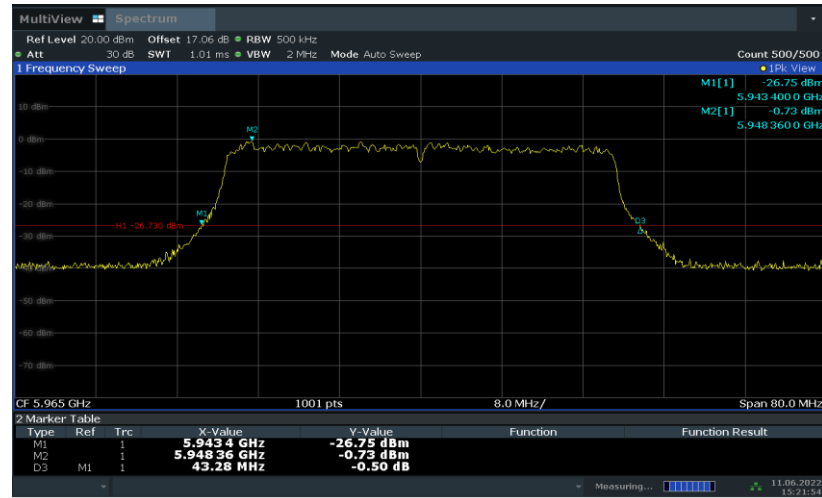

15:21:54 11.06.2022

Fig.27 Occupied 26dB Bandwidth (802.11ax-HE40, 5965MHz)

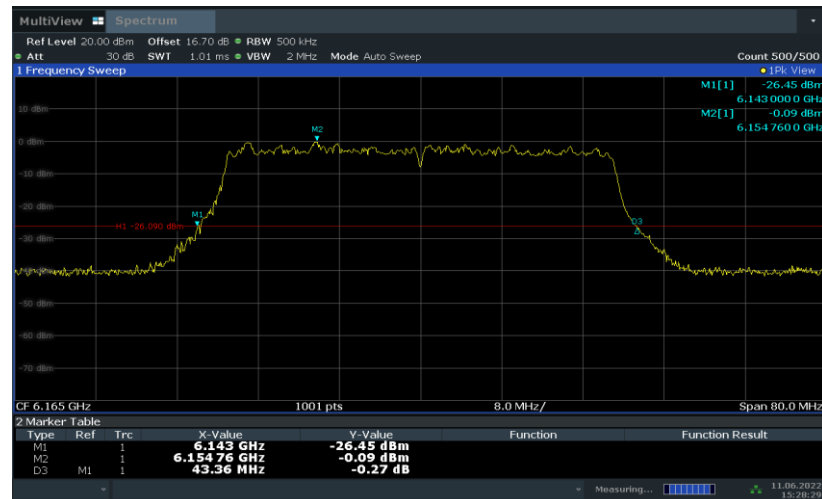

15:28:30 11.06.2022

Fig.28 Occupied 26dB Bandwidth (802.11ax-HE40, 6165MHz)

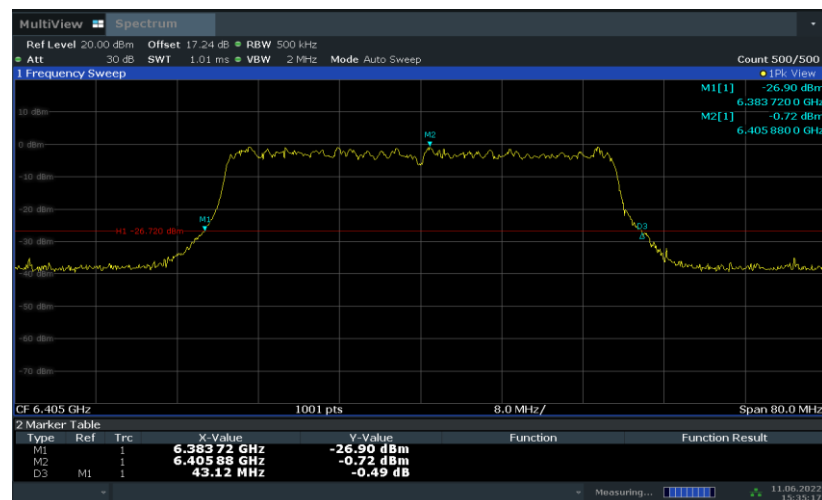

15:35:17 11.06.2022

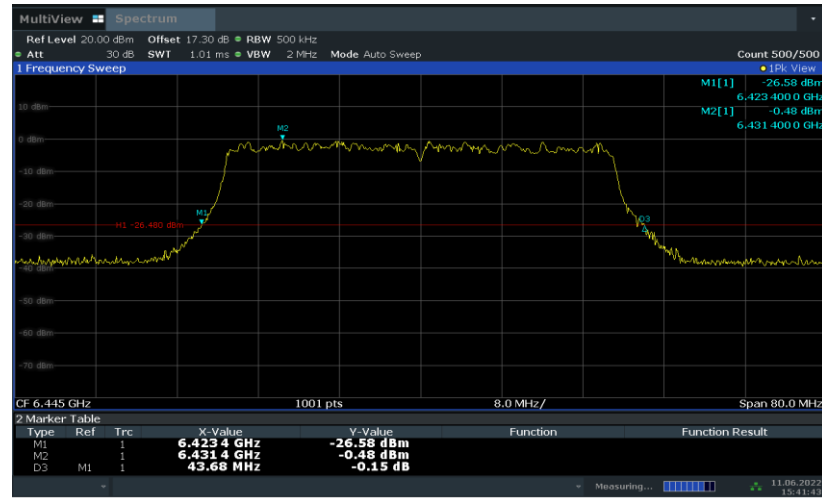
Fig.29 Occupied 26dB Bandwidth (802.11ax-HE40, 6405MHz)

15:41:44 11.06.2022

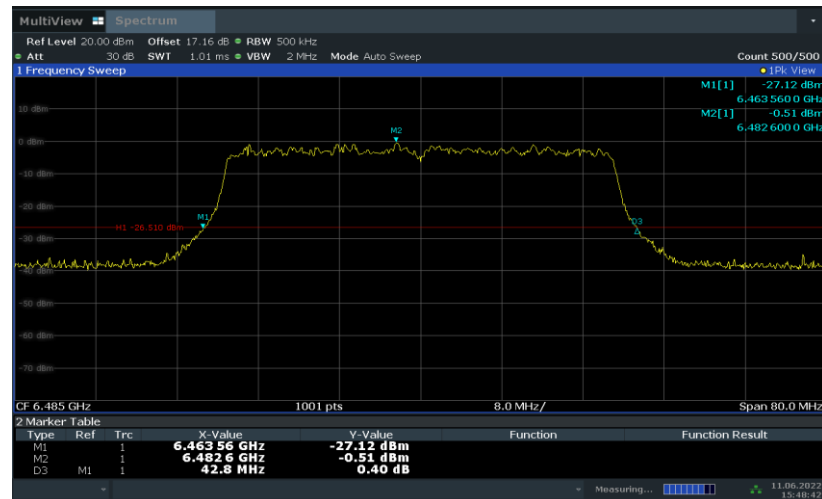
Fig.30 Occupied 26dB Bandwidth (802.11ax-HE40, 6445MHz)

15:48:43 11.06.2022

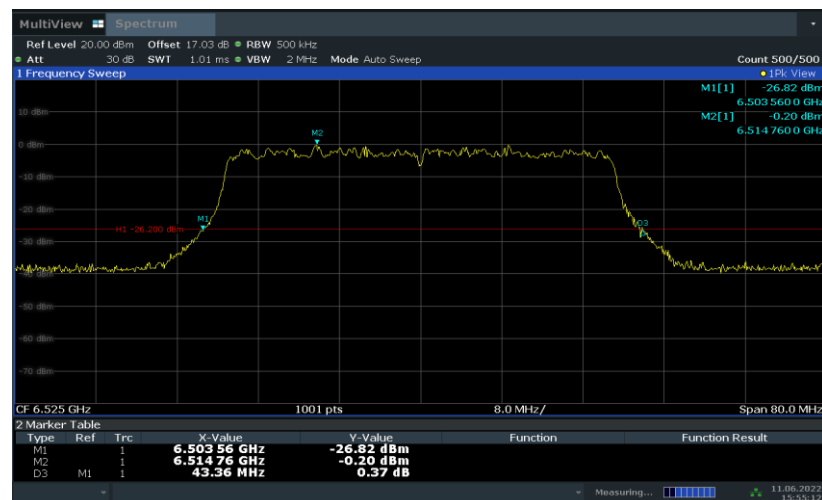
Fig.31 Occupied 26dB Bandwidth (802.11ax-HE40, 6485MHz)

15:55:13 11.06.2022

Fig.32 Occupied 26dB Bandwidth (802.11ax-HE40, 6525MHz)

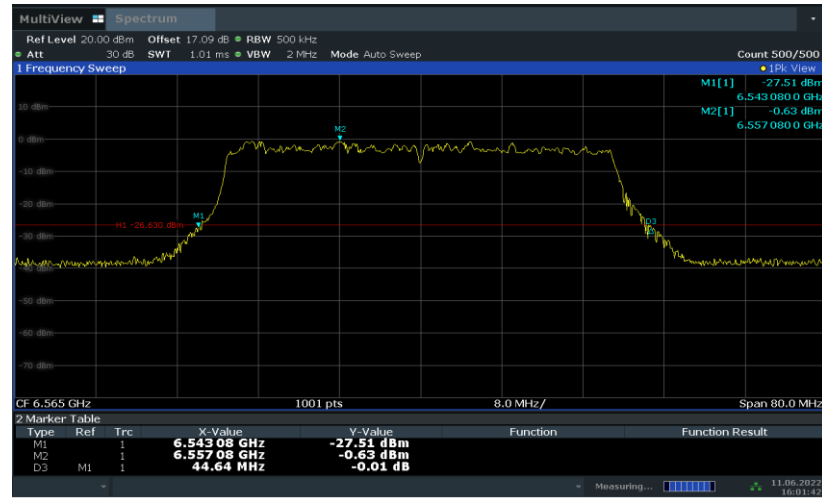

16:01:42 11.06.2022

Fig.33 Occupied 26dB Bandwidth (802.11ax-HE40, 6565MHz)

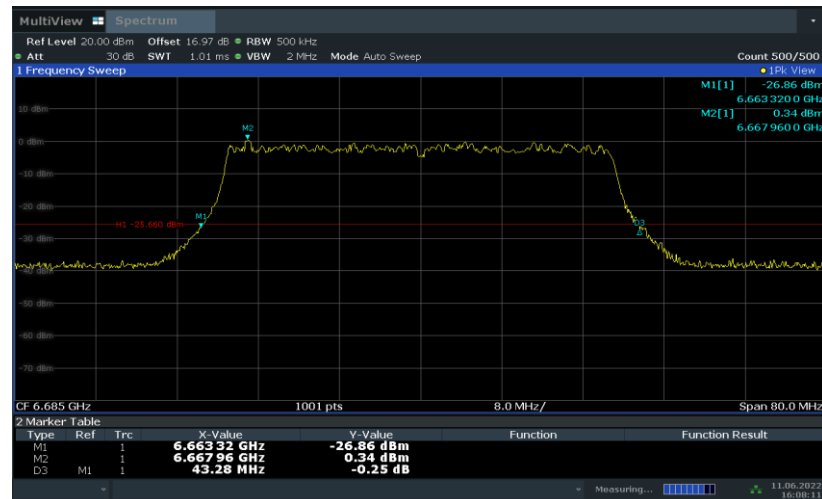

16:08:11 11.06.2022

Fig.34 Occupied 26dB Bandwidth (802.11ax-HE40, 6685MHz)

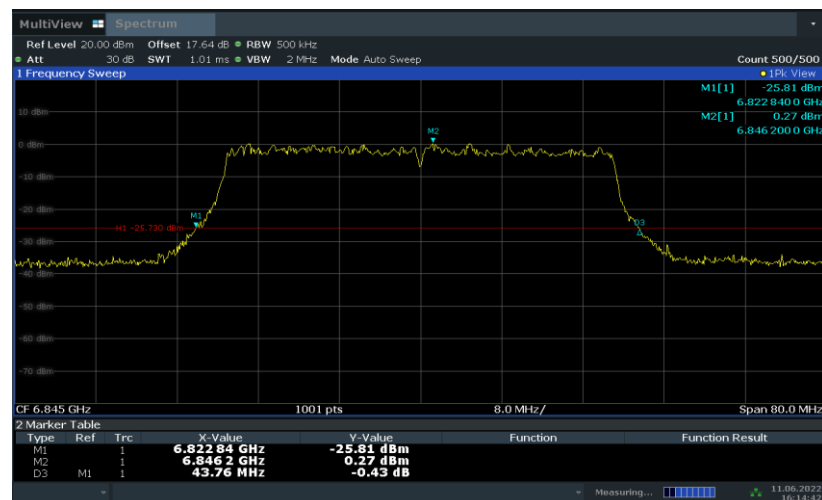

16:14:43 11.06.2022

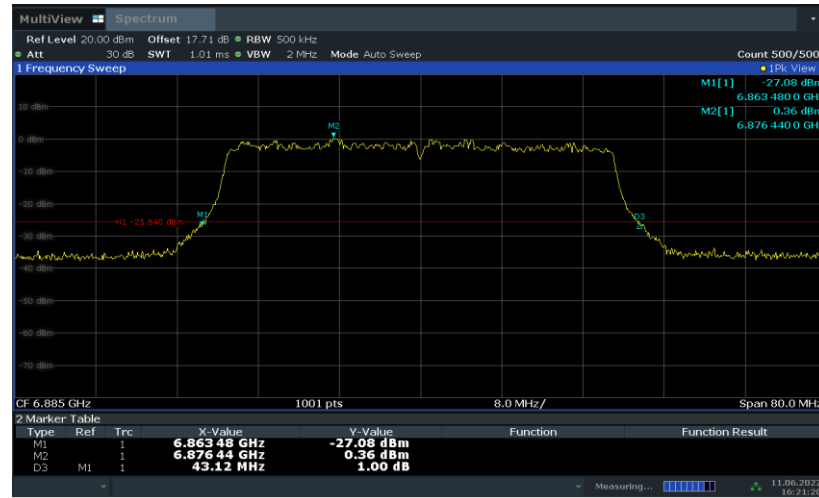
Fig.35 Occupied 26dB Bandwidth (802.11ax-HE40, 6845MHz)

16:21:20 11.06.2022

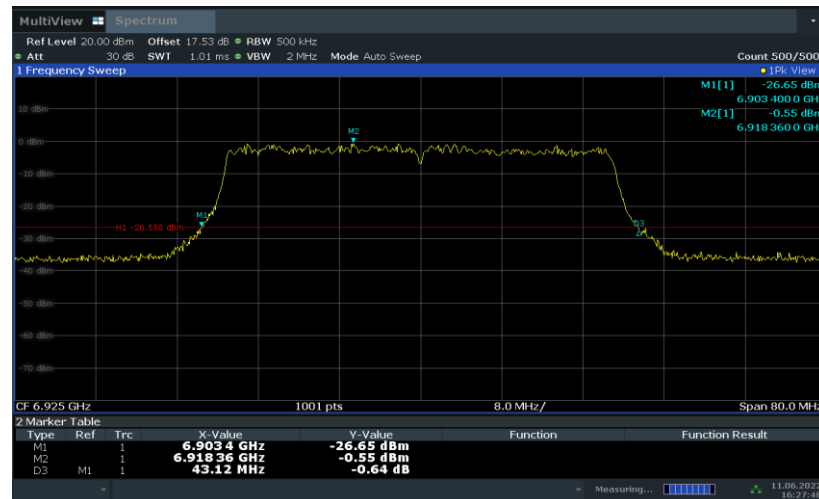
Fig.36 Occupied 26dB Bandwidth (802.11ax-HE40, 6885MHz)

16:27:49 11.06.2022

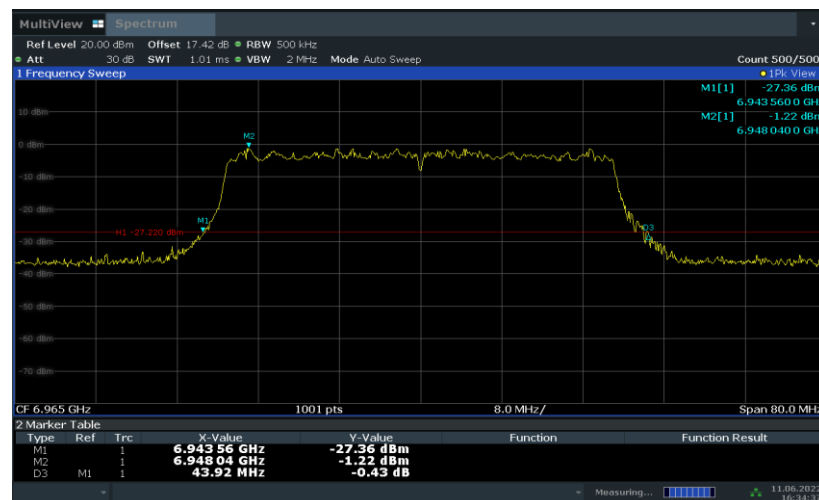
Fig.37 Occupied 26dB Bandwidth (802.11ax-HE40, 6925MHz)

16:34:37 11.06.2022

Fig.38 Occupied 26dB Bandwidth (802.11ax-HE40, 6969MHz)

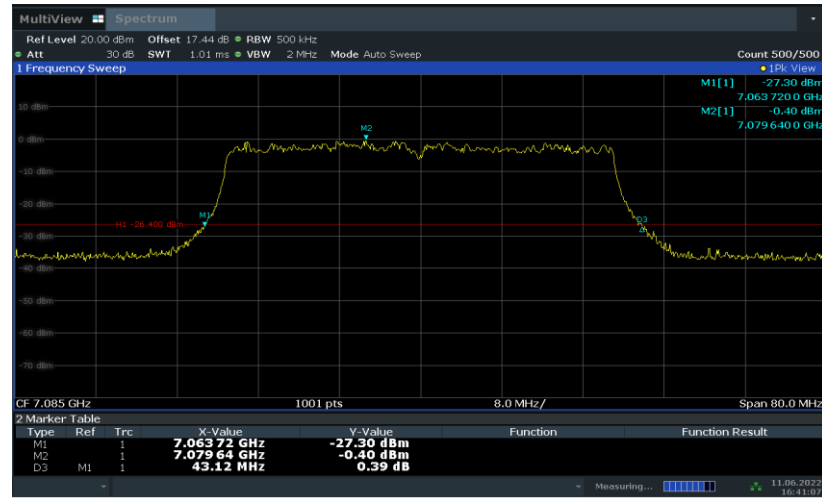

16:41:08 11.06.2022

Fig.39 Occupied 26dB Bandwidth (802.11ax-HE40, 7085MHz)

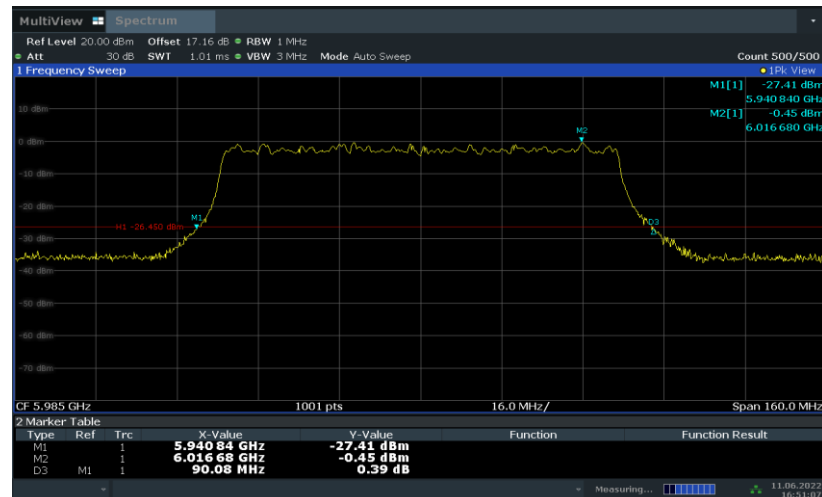

16:51:07 11.06.2022

Fig.40 Occupied 26dB Bandwidth (802.11ax-HE80, 5985MHz)

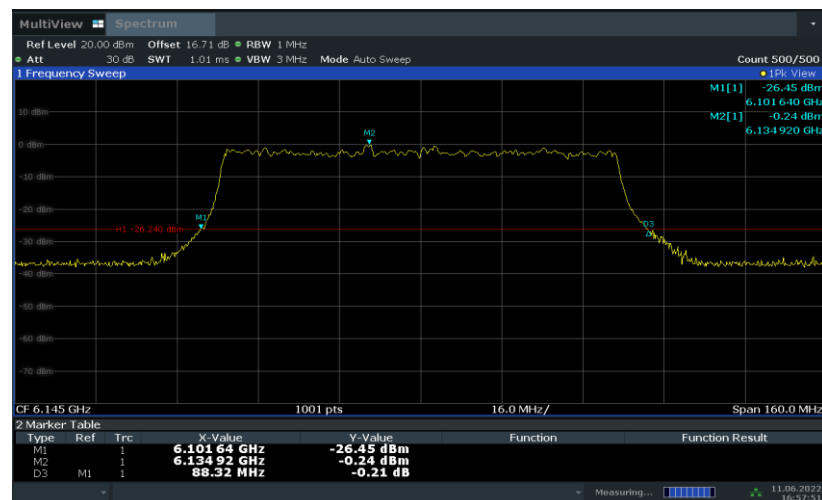

16:57:52 11.06.2022

Fig.41 Occupied 26dB Bandwidth (802. 11ax-HE80, 6145MHz)

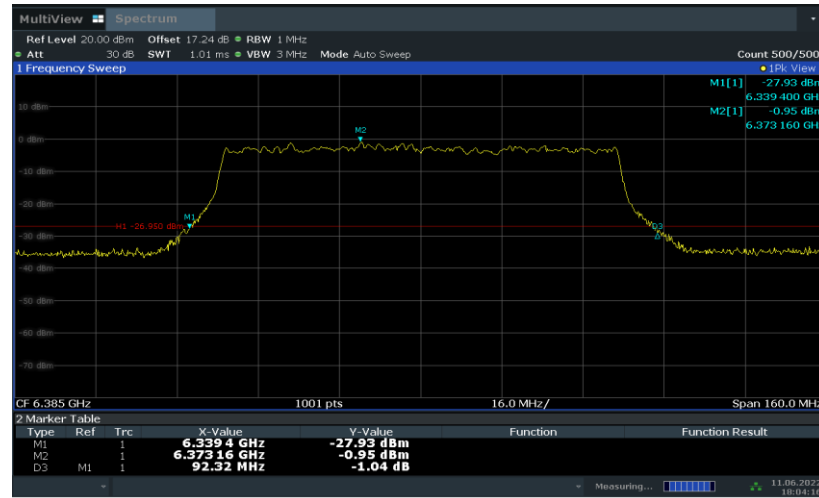

18:04:17 11.06.2022

Fig.42 Occupied 26dB Bandwidth (802. 11ax-HE80, 6385MHz)

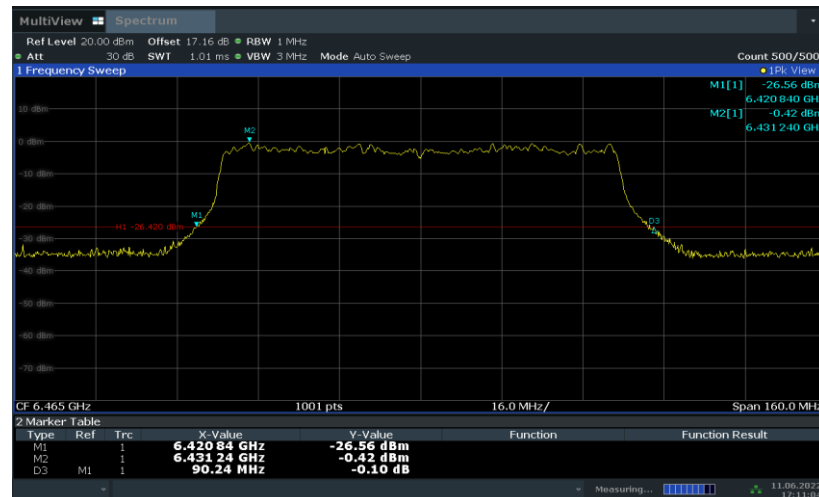

17:11:04 11.06.2022

Fig.43 Occupied 26dB Bandwidth (802. 11ax-HE80, 6465MHz)

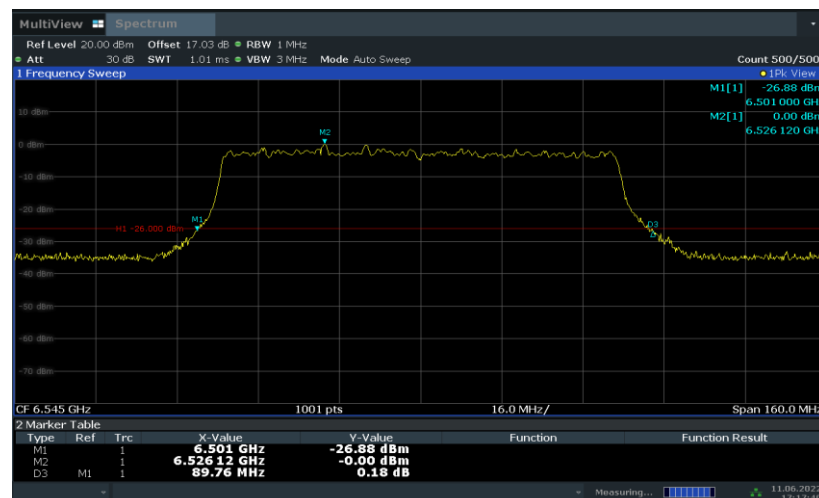

17:17:40 11.06.2022

Fig.44 Occupied 26dB Bandwidth (802. 11ax-HE80, 6545MHz)

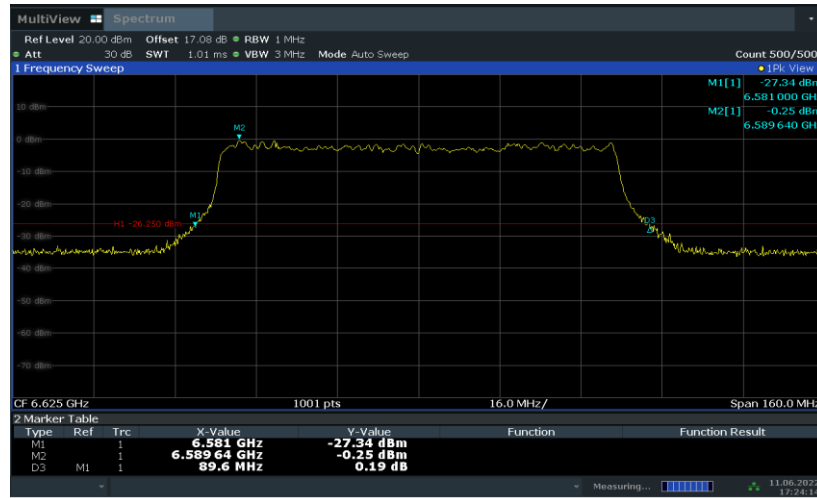

17:24:15 11.06.2022

Fig.45 Occupied 26dB Bandwidth (802. 11ax-HE80, 6625MHz)

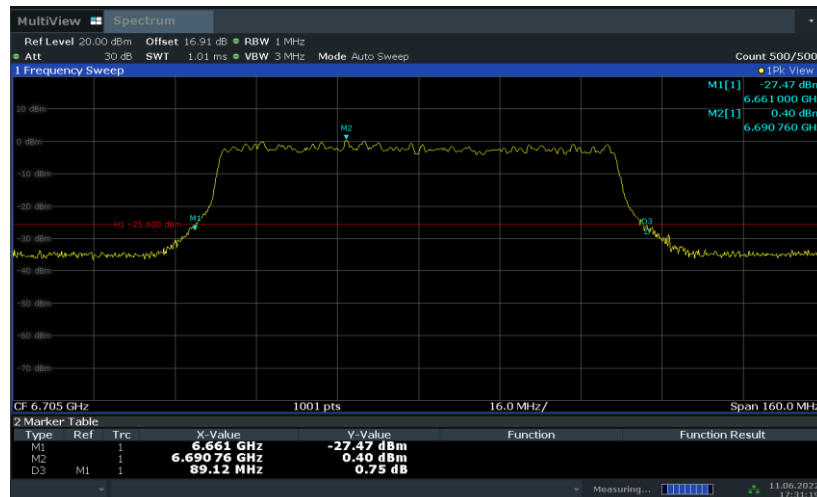

17:31:19 11.06.2022

Fig.46 Occupied 26dB Bandwidth (802. 11ax-HE80, 6705MHz)

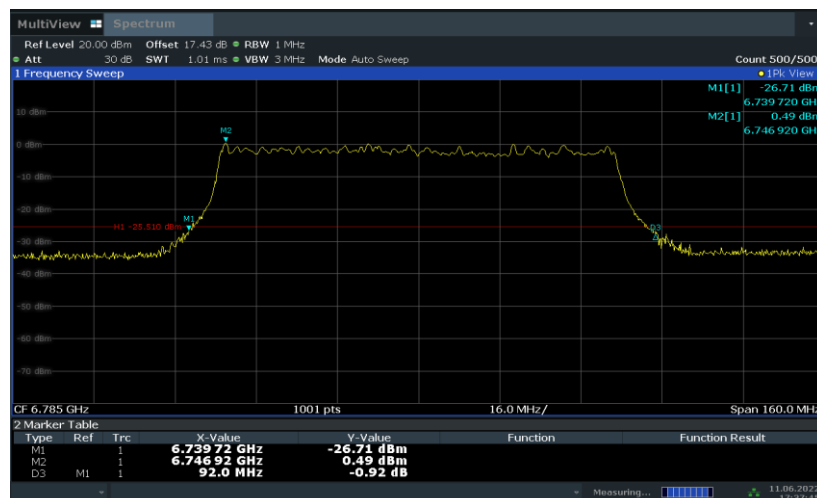

17:37:46 11.06.2022

Fig.47 Occupied 26dB Bandwidth (802. 11ax-HE80, 6785MHz)

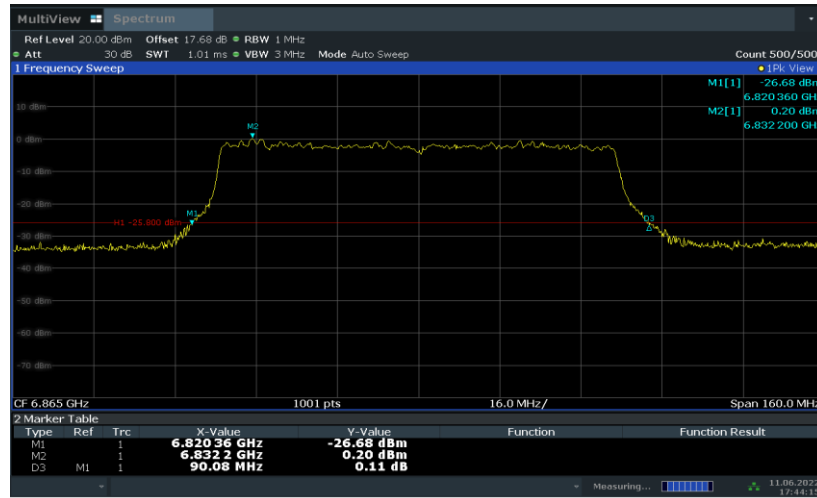

17:44:15 11.06.2022

Fig.48 Occupied 26dB Bandwidth (802. 11ax-HE80, 6865MHz)

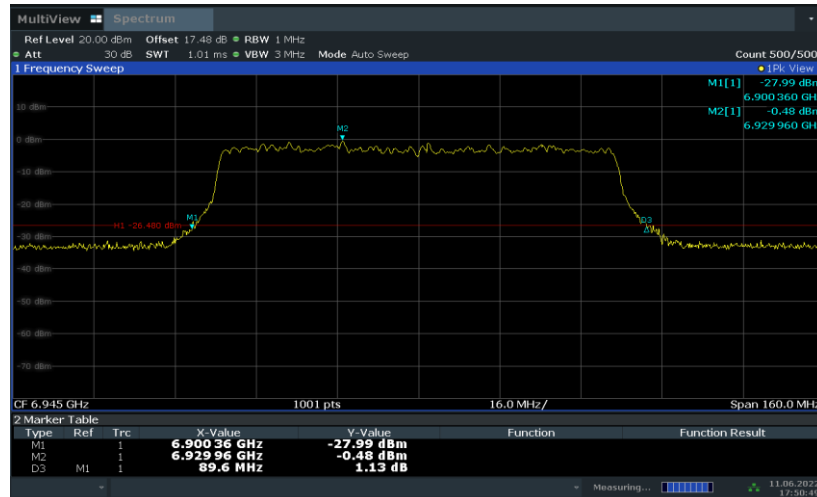

17:50:50 11.06.2022

Fig.49 Occupied 26dB Bandwidth (802. 11ax-HE80, 6945MHz)

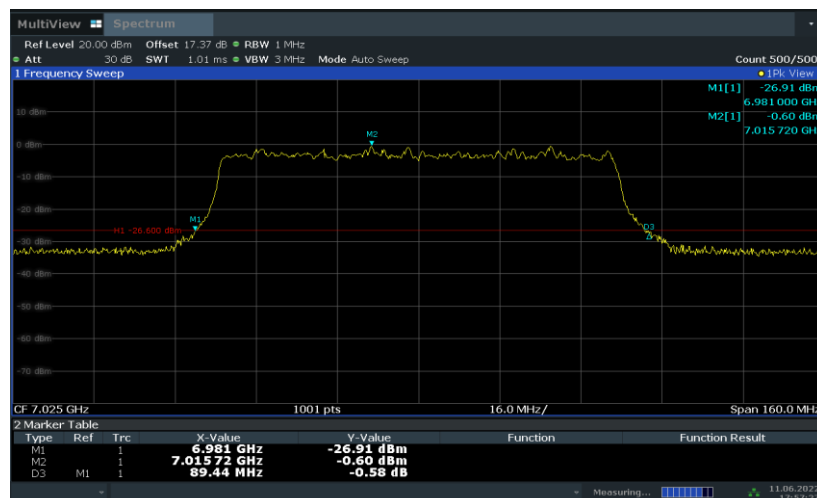

17:57:28 11.06.2022

Fig.50 Occupied 26dB Bandwidth (802. 11ax-HE80, 7025MHz)

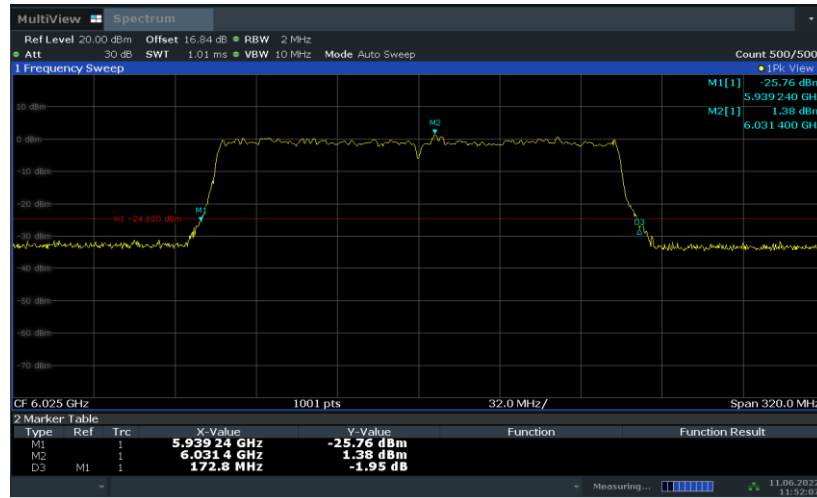

11:52:07 11.06.2022

Fig.51 Occupied 26dB Bandwidth (802. 11ax-HE160, 6025MHz)

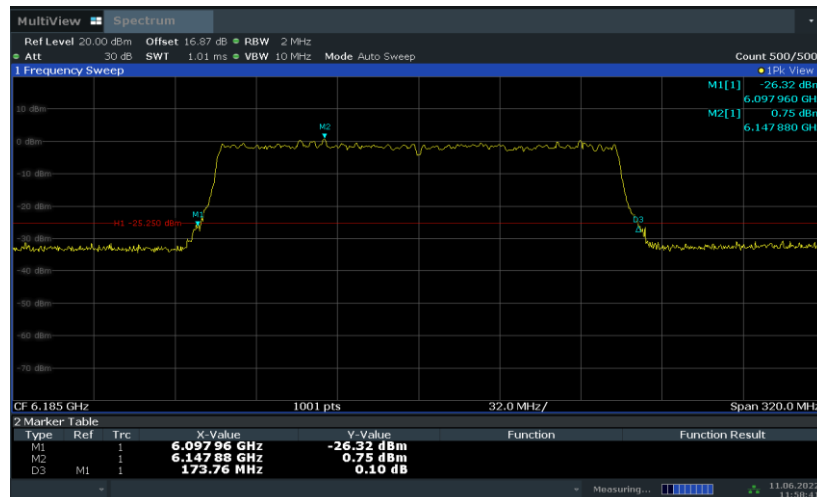

11:58:42 11.06.2022

Fig.52 Occupied 26dB Bandwidth (802. 11ax-HE160, 6185MHz)

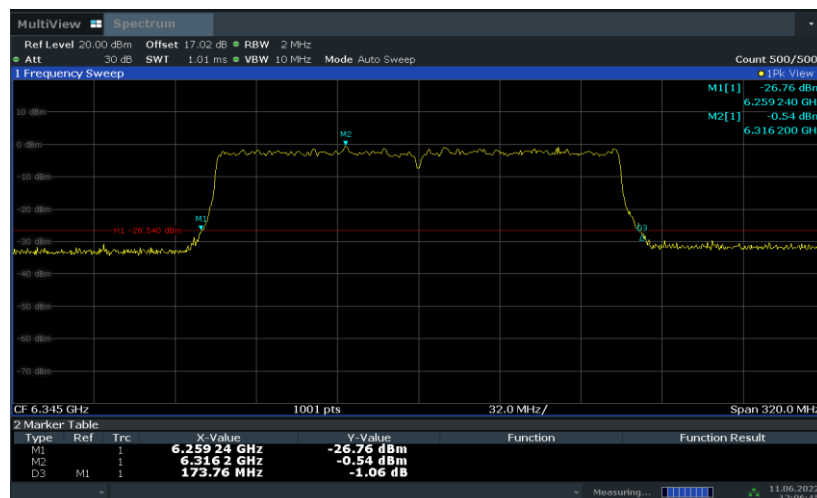

12:06:46 11.06.2022

Fig.53 Occupied 26dB Bandwidth (802. 11ax-HE160, 6345MHz)

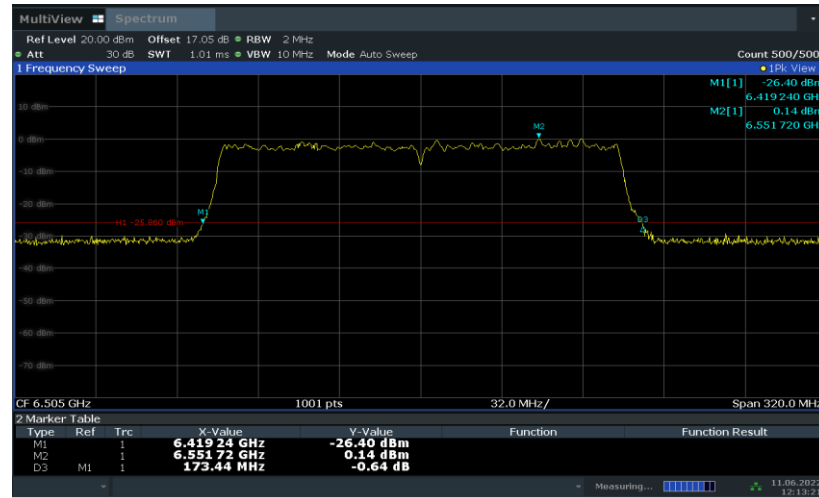

Fig.54 Occupied 26dB Bandwidth (802. 11ax-HE160, 6505MHz)

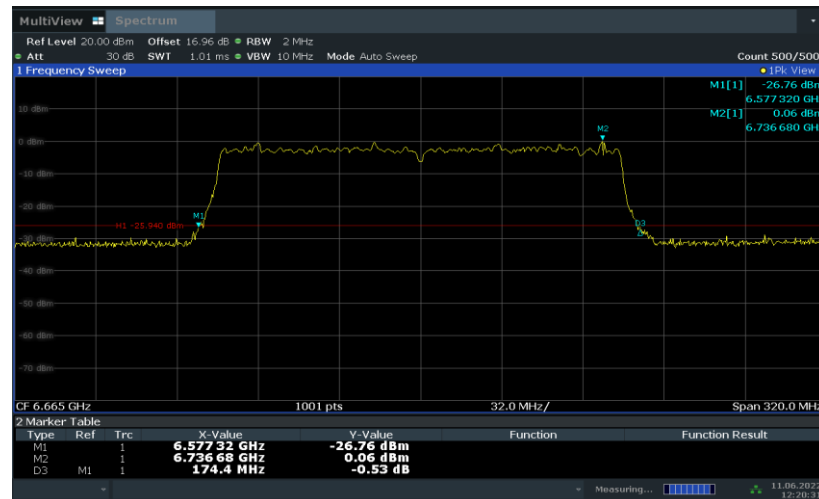

Fig.55 Occupied 26dB Bandwidth (802. 11ax-HE160, 6665MHz)

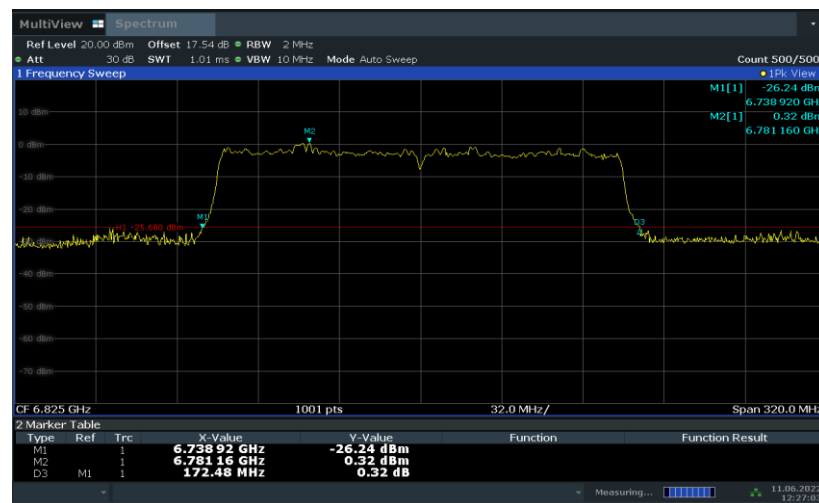

Fig.56 Occupied 26dB Bandwidth (802. 11ax-HE160, 6825MHz)

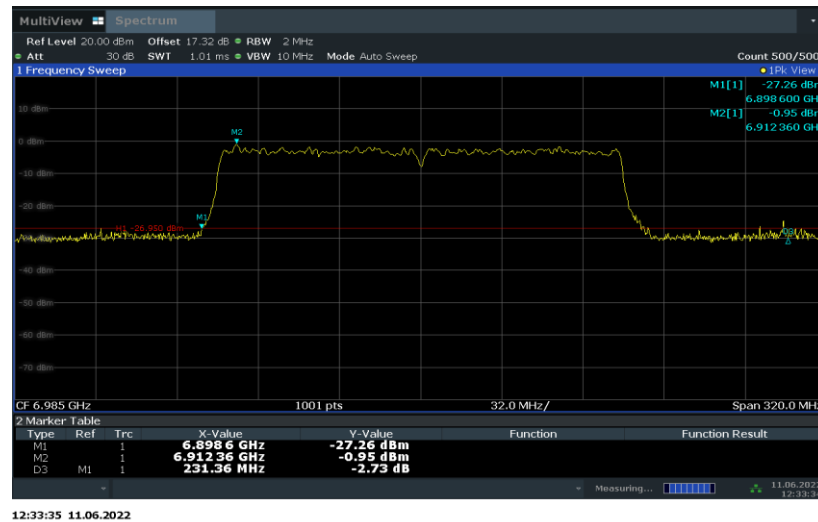

Fig.57 Occupied 26dB Bandwidth (802. 11ax-HE160 6985MHz)

A.5. 99% Occupied bandwidth

Method of Measurement: See ANSI C63.10-2013-clause 12.4.2.

- a) The instrument center frequency is set to the nominal EUT channel center frequency. The frequency span for the spectrum analyzer shall be between 1.5 times and 5.0 times the OBW.
- b) The nominal IF filter bandwidth (3 dB RBW) shall be in the range of 1% to 5% of the OBW, and VBW shall be approximately three times the RBW, unless otherwise specified by the applicable requirement.
- c) Set the reference level of the instrument as required, keeping the signal from exceeding the maximum input mixer level for linear operation. In general, the peak of the spectral envelope shall be more than $[10 \log (OBW/RBW)]$ below the reference level. Specific guidance is given in 4.1.5.2.
- d) Step a) through step c) might require iteration to adjust within the specified range.
- e) Video averaging is not permitted. Where practical, a sample detection and single sweep mode shall be used. Otherwise, peak detection and max hold mode (until the trace stabilizes) shall be used.
- f) Use the 99% power bandwidth function of the instrument (if available) and report the measured bandwidth.
- g) If the instrument does not have a 99% power bandwidth function, then the trace data points are recovered and directly summed in linear power terms. The recovered amplitude data points, beginning at the lowest frequency, are placed in a running sum until 0.5% of the total is reached; that frequency is recorded as the lower frequency. The process is repeated until 99.5% of the total is reached; that frequency is recorded as the upper frequency. The 99% power bandwidth is the difference between these two frequencies.
- h) The occupied bandwidth shall be reported by providing plot(s) of the measuring instrument display; the plot axes and the scale units per division shall be clearly labeled. Tabular data may be reported in addition to the plot(s).

Measurement Result:

Mode	Frequency	99% Occupied bandwidth (MHz)		conclusion
802.11a	5955MHz (Ch1)	Fig.58	16.64	P
	6175MHz (Ch45)	Fig.59	16.66	P
	6415MHz (Ch93)	Fig.60	16.70	P
	6435MHz (Ch97)	Fig.61	16.63	P
	6475MHz (Ch105)	Fig.62	16.67	P
	6515MHz (Ch113)	Fig.63	16.69	P
	6535MHz (Ch117)	Fig.64	16.67	P
	6695MHz (Ch149)	Fig.65	16.65	P
	6855MHz (Ch181)	Fig.66	16.71	P
	6875MHz (Ch185)	Fig.67	16.68	P
	6895MHz (ch189)	Fig.68	16.79	P
	6995MHz (Ch209)	Fig.69	16.71	P
	7115MHz (Ch233)	Fig.70	16.71	P
802.11ax HE20 (full RU)	5955MHz (Ch1)	Fig.71	19.18	P
	6175MHz (Ch45)	Fig.72	19.18	P
	6415MHz (Ch93)	Fig.73	19.23	P
	6435MHz (Ch97)	Fig.74	19.17	P
	6475MHz (Ch105)	Fig.75	19.24	P
	6515MHz (Ch113)	Fig.76	19.31	P
	6535MHz (Ch117)	Fig.77	19.23	P
	6695MHz (Ch149)	Fig.78	19.19	P
	6855MHz (Ch181)	Fig.79	19.22	P
	6875MHz (Ch185)	Fig.80	19.20	P
	6895MHz (ch189)	Fig.81	19.18	P
	6995MHz (Ch209)	Fig.82	19.22	P
	7115MHz (Ch233)	Fig.83	19.21	P
802.11ax HE40 (full RU)	5965MHz (Ch3)	Fig.84	38.20	P
	6165MHz (Ch43)	Fig.85	38.24	P
	6405MHz (Ch91)	Fig.86	38.26	P
	6445MHz (Ch99)	Fig.87	38.22	P
	6485MHz (Ch107)	Fig.88	38.27	P
	6525MHz (Ch115)	Fig.89	38.24	P
	6565MHz (Ch123)	Fig.90	38.27	P
	6685MHz (Ch147)	Fig.91	38.42	P
	6845MHz (Ch179)	Fig.92	38.28	P
	6885MHz (Ch187)	Fig.93	38.44	P
	6925MHz (ch195)	Fig.94	38.24	P
	6965MHz (Ch203)	Fig.95	38.58	P
	7085MHz (Ch227)	Fig.96	38.31	P

802.11ax HE80 (full RU)	5985MHz (Ch7)	Fig.97	78.40	P
	6145MHz (Ch39)	Fig.98	78.83	P
	6385MHz (Ch87)	Fig.99	78.83	P
	6465MHz (Ch103)	Fig.100	78.54	P
	6545MHz (Ch119)	Fig.101	78.51	P
	6625MHz (Ch135)	Fig.102	78.61	P
	6705MHz (Ch151)	Fig.103	78.57	P
	6785MHz (Ch167)	Fig.104	78.57	P
	6865MHz (Ch183)	Fig.105	78.84	P
	6945MHz (Ch199)	Fig.106	78.77	P
7025MHz (Ch215)	Fig.107	78.48	P	
802.11ax HE160 (full RU)	6025MHz (Ch15)	Fig.108	158.84	P
	6185MHz (Ch47)	Fig.109	159.06	P
	6345MHz (Ch79)	Fig.110	159.14	P
	6505MHz (Ch111)	Fig.111	158.87	P
	6665MHz (Ch143)	Fig.112	159.08	P
	6825MHz (Ch175)	Fig.113	159.98	P
6985MHz (Ch207)	Fig.114	159.46	P	

Conclusion: PASS

Test graphs as below:

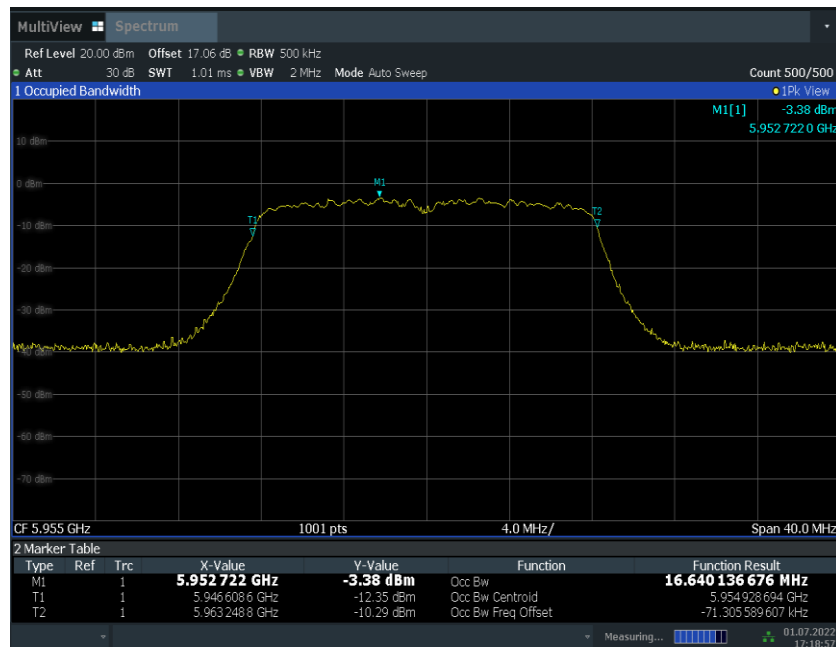

17:18:57 01.07.2022

Fig.58 99% Occupied bandwidth (802.11a, 5955MHz)

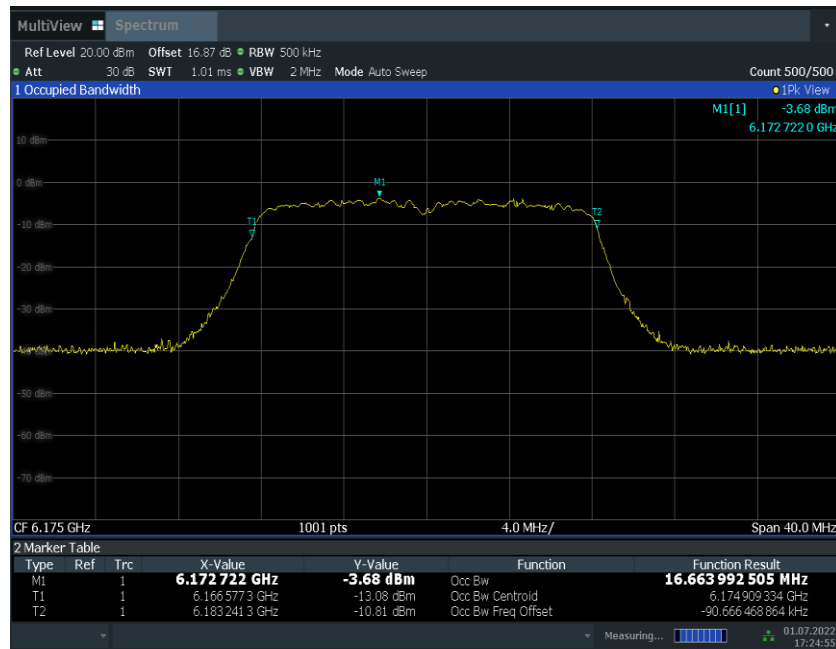

17:24:55 01.07.2022

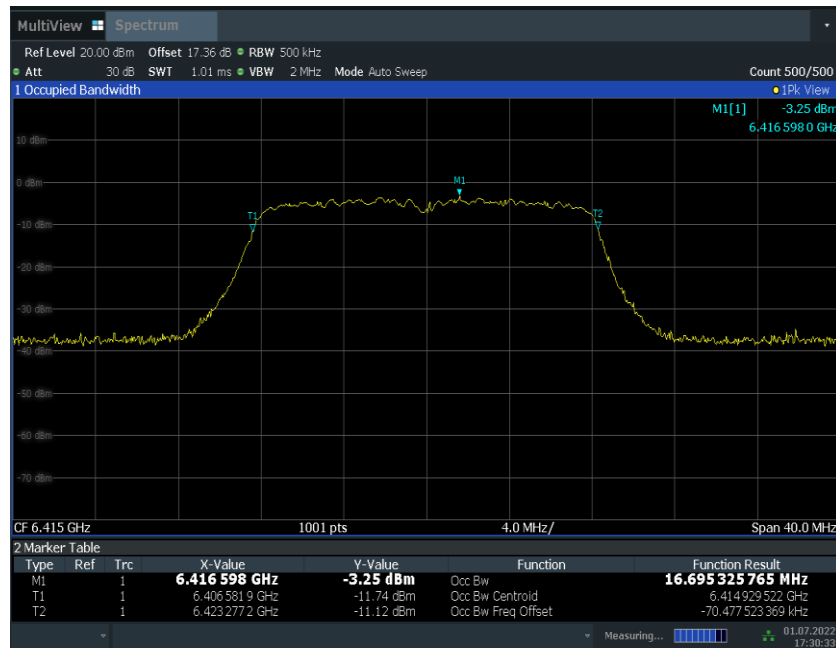
Fig.59 99% Occupied Bandwidth (802.11a, 6175MHz)

17:30:34 01.07.2022

Fig.60 99% Occupied Bandwidth (802.11a, 6415MHz)

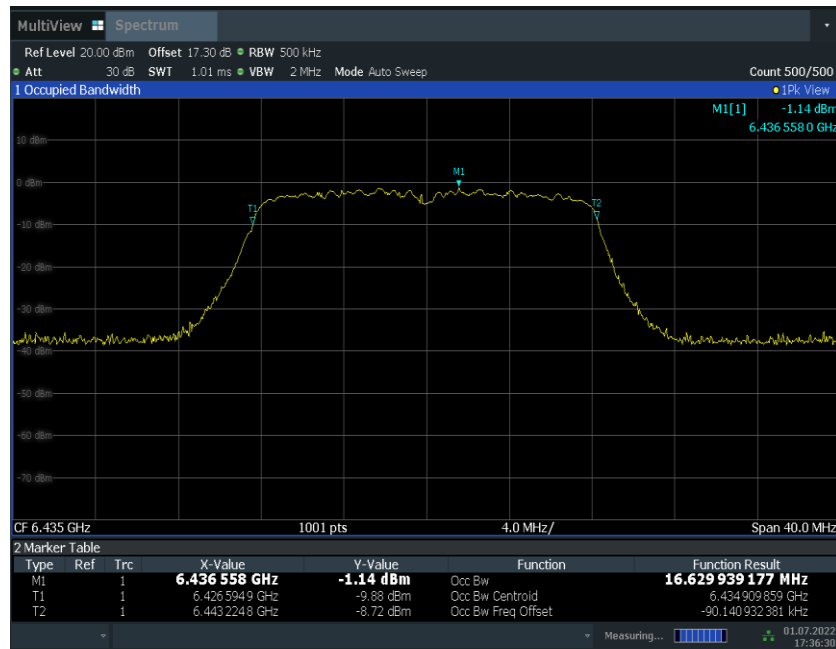

17:36:30 01.07.2022

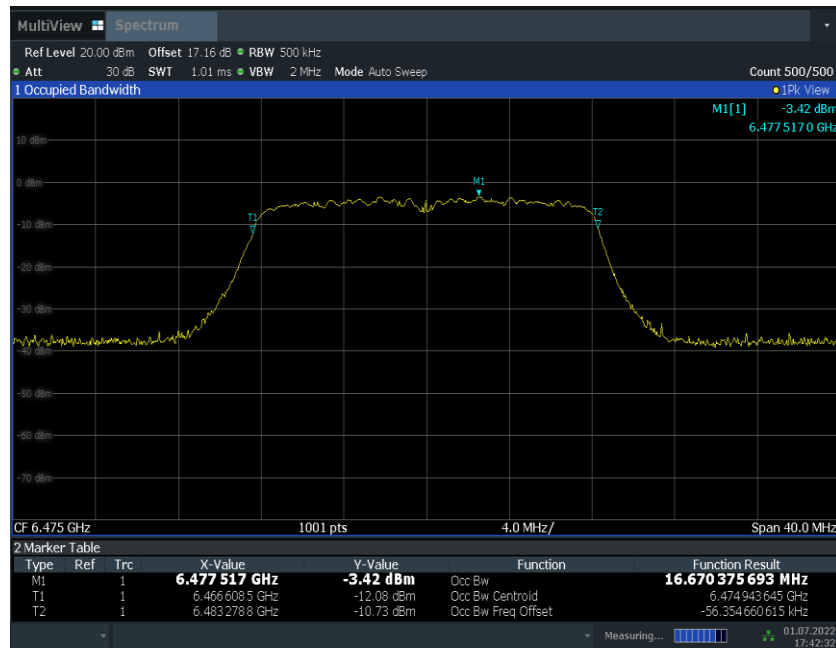
Fig.61 99% Occupied Bandwidth (802.11a, 6435MHz)

17:42:33 01.07.2022

Fig.62 99% Occupied Bandwidth (802.11a, 6475MHz)