

# FCC Radio Test Report

**FCC ID: RWO-RZ090368QCNFA****This report concerns: Class II Permissive Changes**

**Report No.** : BTL-FCCP-6-2212C001  
**Equipment** : Notebook PC  
**Model Name** : RZ09-0482  
**Brand Name** : RAZER  
**Applicant** : Razer Inc.  
**Address** : 9 Pasteur, Suite 100, Irvine, CA92618, USA.  
**Manufacturer** : Razer Inc.  
**Address** : 9 Pasteur, Suite 100, Irvine, CA92618, USA.

**Radio Function** : RLAN 5 GHz (U-NII 4)

**FCC Rule Part(s)** : FCC CFR Title 47, Part 15, Subpart E (15.407)  
**Measurement Procedure(s)** : ANSI C63.10-2013

**Date of Receipt** : 2022/12/19  
**Date of Test** : 2022/12/19 ~ 2023/2/3  
**Issued Date** : 2023/4/24

The above equipment has been tested and found in compliance with the requirement of the above standards by BTL Inc.

**Prepared by** :

*Eric Lee*

Eric Lee, Engineer

**Approved by** :

*Jerry Chuang*

Jerry Chuang, Supervisor



**BTL Inc.**

No.18, Ln. 171, Sec. 2, Jiuzong Rd., Neihu Dist., Taipei City 114, Taiwan

Tel: +886-2-2657-3299 Fax: +886-2-2657-3331 Web: www.newbtl.com Service mail: btl\_qa@newbtl.com

**Declaration**

**BTL** represents to the client that testing is done in accordance with standard procedures as applicable and that test instruments used has been calibrated with standards traceable to international standard(s) and/or national standard(s).

**BTL's** reports apply only to the specific samples tested under conditions. It is manufacture's responsibility to ensure that additional production units of this model are manufactured with the identical electrical and mechanical components. **BTL** shall have no liability for any declarations, inferences or generalizations drawn by the client or others from **BTL** issued reports.

This report is the confidential property of the client. As a mutual protection to the clients, the public and ourselves, the test report shall not be reproduced, except in full, without our written approval.

**BTL's** laboratory quality assurance procedures are in compliance with the **ISO/IEC 17025** requirements, and accredited by the conformity assessment authorities listed in this test report.

**BTL** is not responsible for the sampling stage, so the results only apply to the sample as received.

The information, data and test plan are provided by manufacturer which may affect the validity of results, so it is manufacturer's responsibility to ensure that the apparatus meets the essential requirements of applied standards and in all the possible configurations as representative of its intended use.

**Limitation**

For the use of the authority's logo is limited unless the Test Standard(s)/Scope(s)/Item(s) mentioned in this test report is (are) included in the conformity assessment authorities acceptance respective.

Please note that the measurement uncertainty is provided for informational purpose only and are not use in determining the Pass/Fail results.

**CONTENTS**

REVISION HISTORY	4
1 SUMMARY OF TEST RESULTS	5
1.1 TEST FACILITY	6
1.2 MEASUREMENT UNCERTAINTY	6
1.3 TEST ENVIRONMENT CONDITIONS	6
1.4 TABLE OF PARAMETERS OF TEST SOFTWARE SETTING	7
2 GENERAL INFORMATION	8
2.1 DESCRIPTION OF EUT	8
2.2 TEST MODES	10
2.3 BLOCK DIAGRAM SHOWING THE CONFIGURATION OF SYSTEM TESTED	11
2.4 SUPPORT UNITS	12
3 AC POWER LINE CONDUCTED EMISSIONS TEST	13
3.1 LIMIT	13
3.2 TEST PROCEDURE	13
3.3 DEVIATION FROM TEST STANDARD	13
3.4 TEST SETUP	14
3.5 TEST RESULT	14
4 RADIATED EMISSIONS TEST	15
4.1 LIMIT	15
4.2 TEST PROCEDURE	16
4.3 DEVIATION FROM TEST STANDARD	16
4.4 TEST SETUP	17
4.5 EUT OPERATING CONDITIONS	18
4.6 TEST RESULT – BELOW 30 MHZ	18
4.7 TEST RESULT – 30 MHZ TO 1 GHZ	18
4.8 TEST RESULT – ABOVE 1 GHZ	18
5 MAXIMUM E.I.R.P. TEST	19
5.1 LIMIT	19
5.2 TEST PROCEDURE	19
5.3 DEVIATION FROM TEST STANDARD	19
5.4 TEST SETUP	19
5.5 EUT OPERATING CONDITIONS	19
5.6 TEST RESULT	19
6 LIST OF MEASURING EQUIPMENTS	20
7 EUT TEST PHOTO	21
8 EUT PHOTOS	21
APPENDIX A AC POWER LINE CONDUCTED EMISSIONS	22
APPENDIX B RADIATED EMISSIONS - 30 MHZ TO 1 GHZ	27
APPENDIX C RADIATED EMISSIONS - ABOVE 1 GHZ	30
APPENDIX D MAXIMUM E.I.R.P.	40

**REVISION HISTORY**

Report No.	Version	Description	Issued Date	Note
BTL-FCCP-6-2212C001	R00	Original Report.	2023/2/10	Invalid
BTL-FCCP-6-2212C001	R01	Revised report to address TCB's comments.	2023/4/24	Valid

## 1 SUMMARY OF TEST RESULTS

Test procedures according to the technical standards.

Standard(s) Section	Description	Test Result	Judgement	Remark
15.207	AC Power Line Conducted Emissions	APPENDIX A	Pass	-----
15.205 15.209 15.407(b)	Radiated Emissions	APPENDIX B APPENDIX C	Pass	-----
15.407(e)	6 dB Bandwidth	-----	Pass	-----
15.407(a)	Maximum E.I.R.P.	APPENDIX D	Pass	-----
15.407(a)	Power Spectral Density	-----	Pass	-----
15.203	Antenna Requirement	-----	Pass	-----
15.407(c)	Automatically Discontinue Transmission	-----	Pass	<b>NOTE (3)</b>

**NOTE:**

- (1) "N/A" denotes test is not applicable in this Test Report.
- (2) The report format version is TP.1.1.1.
- (3) The EUT can detect the controlling signal of ACK message transmitting from remote device and verify whether it shall resend or discontinue transmission.
- (4) The antenna gain of EUT is smaller than that of the module. So in this report the worst cases of radiated spurious emissions and AC Power Line Conducted Emissions were evaluated and recorded. And evaluated the output power items and recorded in the report. For the test results of all other test items please refer to module test reports.

### 1.1 TEST FACILITY

The test locations stated below are under the TAF Accreditation Number 0659.

The test location(s) used to collect the test data in this report are:

No. 68-1, Ln. 169, Sec. 2, Datong Rd., Xizhi Dist., New Taipei City 221, Taiwan  
(FCC DN: TW0659)

C05       CB08       CB11       SR10       SR11

No. 72, Ln. 169, Sec. 2, Datong Rd., Xizhi Dist., New Taipei City 221, Taiwan  
(FCC DN: TW0659)

C06       CB21       CB22

### 1.2 MEASUREMENT UNCERTAINTY

The reported uncertainty of measurement  $y \pm U$ , where expanded uncertainty  $U$  is based on a standard uncertainty multiplied by a coverage factor of  $k = 2$ , providing a level of confidence of approximately **95 %**. The measurement instrumentation uncertainty considerations contained in CISPR 16-4-2. The BTL measurement uncertainty is less than the CISPR 16-4-2  $U_{\text{cispr}}$  requirement.

A. AC power line conducted emissions test:

Test Site	Method	Measurement Frequency Range	U (dB)
C05	CISPR	150 kHz ~ 30MHz	3.44

B. Radiated emissions test:

Test Site	Measurement Frequency Range	U (dB)
CB21	0.03 GHz ~ 0.2 GHz	4.17
	0.2 GHz ~ 1 GHz	4.72
	1 GHz ~ 6 GHz	5.21
	6 GHz ~ 18 GHz	5.51
	18 GHz ~ 26 GHz	3.69
	26 GHz ~ 40 GHz	4.23

C. Conducted test:

Test Item	U,(dB)
Output power	0.3669

NOTE:

Unless specifically mentioned, the uncertainty of measurement has not been taken into account to declare the compliance or non-compliance to the specification.

### 1.3 TEST ENVIRONMENT CONDITIONS

Test Item	Environment Condition	Test Voltage	Tested by
AC Power Line Conducted Emissions	21°C, 65%	AC 120V/60Hz	Paul Shen
Radiated emissions below 1 GHz	23°C, 59%	AC 120V/60Hz	Mark Wang
Radiated emissions above 1 GHz	23°C, 59%	AC 120V/60Hz	Mark Wang
Maximum E.I.R.P.	22.2°C, 56%	AC 120V/60Hz	Tim Lee

**1.4 TABLE OF PARAMETERS OF TEST SOFTWARE SETTING**

Test Software	QRCT V4.0			
Mode	5845 MHz	5865 MHz	5885 MHz	Data Rate
IEEE 802.11a	13	13	12.5	6 Mbps
IEEE 802.11ac (VHT20)	13.5	13.5	13	MCS 0
IEEE 802.11ax (HE20)	13.5	13.5	13	MCS 0
Mode	5835 MHz	5875 MHz		Data Rate
IEEE 802.11ac (VHT40)	15.5	16		MCS 0
IEEE 802.11ax (HE40)	16	16.5		MCS 0
Mode	5855 MHz			Data Rate
IEEE 802.11ac (VHT80)	15			MCS 0
IEEE 802.11ax (HE80)	15.5			MCS 0
Mode	5815 MHz			Data Rate
IEEE 802.11ac (VHT160)	14			MCS 0
IEEE 802.11ax (HE160)	14			MCS 0

## 2 GENERAL INFORMATION

### 2.1 DESCRIPTION OF EUT

Equipment	Notebook PC
Model Name	RZ09-0482
Brand Name	RAZER
Model Difference	N/A
Power Source	#1 DC voltage supplied from AC adapter. #2 Supplied from battery. Model: RC30-0482
Power Rating	#1 I/P: 100-240V~3.6A 50/60Hz O/P: 19.5V==11.8A #2 DC 15.4V, 4422mAh, 68.1Wh
Products Covered	1* POWER Adapter: RC30-024801
Operation Band	5850 MHz to 5895 MHz
Operation Frequency	5845 MHz to 5885 MHz
Modulation Technology	IEEE 802.11a/n/ac: OFDM IEEE 802.11ax: OFDMA
Transfer Rate	IEEE 802.11a: 54/48/36/24/18/12/9/6 Mbps IEEE 802.11n: up to 300 Mbps IEEE 802.11ac: up to 1733.4 Mbps IEEE 802.11ax: up to 2402 Mbps
Maximum E.I.R.P.	IEEE 802.11a: 19.50 dBm (0.0379W) IEEE 802.11ac (VHT20): 19.66 dBm (0.0925 W) IEEE 802.11ac (VHT40): 21.89 dBm (0.1544 W) IEEE 802.11ac (VHT80): 21.10 dBm (0.1289 W) IEEE 802.11ac (VHT160): 20.07 dBm (0.1015 W) IEEE 802.11ax (HE20): 19.94 dBm (0.0985 W) IEEE 802.11ax (HE40): 21.80 dBm (0.1512 W) IEEE 802.11ax (HE80): 21.21 dBm (0.1321 W) IEEE 802.11ax (HE160): 20.09 dBm (0.1020 W)
Test Model	RZ09-0482
Sample Status	Engineering Sample
EUT Modification(s)	N/A

**NOTE:**

(1) The above EUT information is declared by manufacturer and for more detailed features description, please refers to the manufacturer's specifications or user's manual.

(2) Channel List:

IEEE 802.11a IEEE 802.11n (HT20) IEEE 802.11ac (VHT20) IEEE 802.11ax (HE20)		IEEE 802.11n (HT40) IEEE 802.11ac (VHT40) IEEE 802.11ax (HE40)		IEEE 802.11ac (VHT80) IEEE 802.11ax (HE80)		IEEE 802.11ac (VHT160) IEEE 802.11ax (HE160)	
Channel	Frequency (MHz)	Channel	Frequency (MHz)	Channel	Frequency (MHz)	Channel	Frequency (MHz)
*169	5845	*167	5835	*171	5855	*163	5815
173	5865	175	5875				
177	5885						

Note: \* U-NII 3 & U-NII 4 span channels



## (3) Table for Filed Antenna:

Ant.	Manufacturer	P/N	Type	Connector	Gain (dBi)
1	Amphenol	BY5973-15-001-C	PIFA	N/A	3.70
2	Amphenol	BY5962-15-002-C	PIFA	N/A	3.72

## Note:

- 1) This EUT supports MIMO 2X2, any transmit signals are uncorrelated with each other, so Directional gain=  $10\log[(10^{G1/10}+10^{G2/10}+...+10^{GN/10})/N]$ dBi, that is Directional gain= $10\log[(10^{3.70/10}+10^{3.72/10})/2]$ dBi= 3.71.
  - 2) Ant.1 refers to main antenna, Ant.2 refers to aux antenna.
  - 3) The AUX antenna connector of the module connected to the MAIN antenna of the EUT and the MAIN antenna connector of the module connected to the AUX antenna of the EUT.
- (4) The above Antenna information are derived from the antenna data sheet provided by manufacturer and for more detailed features description, please refer to the manufacturer's specifications, the laboratory shall not be held responsible.

**2.2 TEST MODES**

Test Items	Test mode	Channel	Note
AC power line conducted emissions	Normal/Idle	-	-
Transmitter Radiated Emissions (below 1GHz)	TX Mode_IEEE 802.11ax (HE160)	163	-
Transmitter Radiated Emissions (above 1GHz)	TX Mode_IEEE 802.11a	169	Bandedge
	TX Mode_IEEE 802.11ac (VHT80)	171	
	TX Mode_IEEE 802.11ax (HE160)	163	
	TX Mode_IEEE 802.11a	169	Harmonic
	TX Mode_IEEE 802.11ac (VHT80)	171	
	TX Mode_IEEE 802.11ax (HE160)	163	
Maximum E.I.R.P.	TX Mode_IEEE 802.11a	169/173/177	-
	TX Mode_IEEE 802.11ac (VHT20)		
	TX Mode_IEEE 802.11ax (HE20)		
	TX Mode_IEEE 802.11ac (VHT40)	167/175	
	TX Mode_IEEE 802.11ax (HE40)		
	TX Mode_IEEE 802.11ac (VHT80)	171	
	TX Mode_IEEE 802.11ax (HE80)		
TX Mode_IEEE 802.11ac (VHT160)	163		
TX Mode_IEEE 802.11ax (HE160)			

**NOTE:**

- (1) For radiated emission band edge test, both Vertical and Horizontal are evaluated, but only the worst case (Vertical) is recorded.

## 2.3 BLOCK DIAGRAM SHOWING THE CONFIGURATION OF SYSTEM TESTED

Equipment letters and Cable numbers refer to item numbers described in the tables of clause 2.4.

AC power line conducted emissions

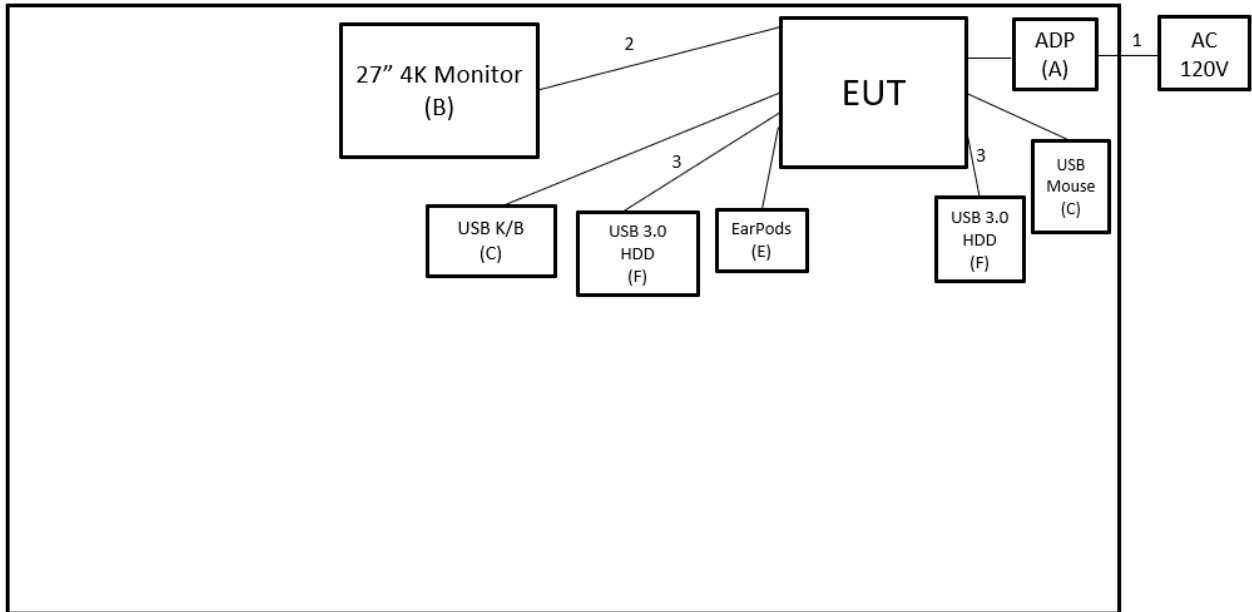

Radiated Emissions

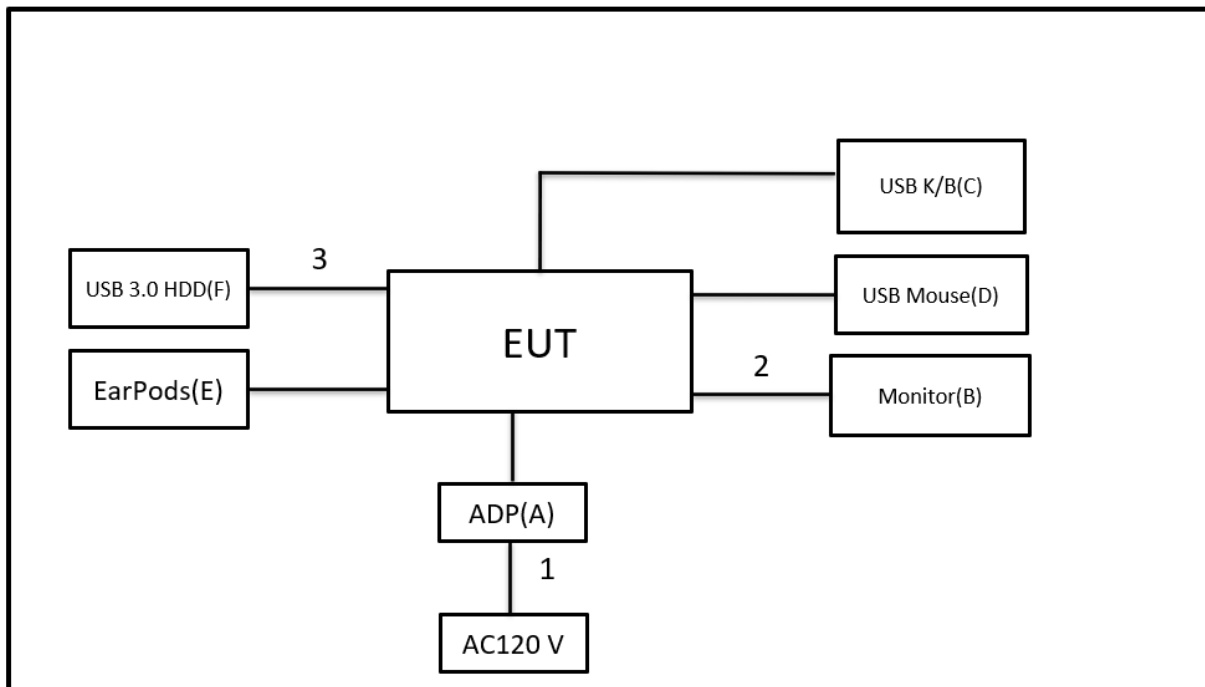

**2.4 SUPPORT UNITS**

## AC power line conducted emissions

Item	Equipment	Brand	Model No.	Series No.	Remarks
A	ADP	Razer	RC30-024801	N/A	Supplied by test requester.
B	27" 4K Monitor	DELL	U2720Q	CN-083VF-WSL00-0B7-332L	Furnished by test lab.
C	USB K/B	DELL	KB216t	CN-0W33XP-L0300-797-05TY-A03	Furnished by test lab.
D	USB Mouse	DELL	MOCZUL	CN-049TWY-PRC00-79E-01HA	Furnished by test lab.
E	EarPods	Apple	A1472	N/A	Furnished by test lab.
F	USB 3.0 HDD	WD	WDBC3C0010BSL-0B	WX81A88ALJUC	Furnished by test lab.

Item	Shielded	Ferrite Core	Length	Cable Type	Remarks
1	N/A	N/A	1m	Power Cord	Furnished by test lab.
2	N/A	N/A	1.7m	HDMI Cable	Furnished by test lab.
3	N/A	N/A	0.18m	Type C to Type C Cable	Furnished by test lab.

## Radiated Emissions

Item	Equipment	Brand	Model No.	Series No.	Remarks
A	ADP	Razer	RC30-024801	N/A	Supplied by test requester.
B	27" 4K Monitor	DELL	U2720Q	CN-083VF-WSL00-0B7-332L	Furnished by test lab.
C	USB K/B	DELL	KB216t	CN-0W33XP-L0300-797-05TY-A03	Furnished by test lab.
D	USB Mouse	DELL	MOCZUL	CN-049TWY-PRC00-79E-01HA	Furnished by test lab.
E	EarPods	Apple	A1472	N/A	Furnished by test lab.
F	USB 3.0 HDD	WD	WDBC3C0010BSL-0B	WX81A88ALJUC	Furnished by test lab.

Item	Shielded	Ferrite Core	Length	Cable Type	Remarks
1	N/A	N/A	1m	Power Cord	Supplied by test requester.
2	N/A	N/A	1.7m	HDMI Cable	Furnished by test lab.
3	N/A	N/A	0.18m	Type C to Type C Cable	Furnished by test lab.

### 3 AC POWER LINE CONDUCTED EMISSIONS TEST

#### 3.1 LIMIT

Frequency (MHz)	Limit (dB $\mu$ V)	
	Quasi-peak	Average
0.15 - 0.5	66 - 56 *	56 - 46 *
0.50 - 5.0	56	46
5.0 - 30.0	60	50

**NOTE:**

- (1) The tighter limit applies at the band edges.
- (2) The limit of " \* " marked band means the limitation decreases linearly with the logarithm of the frequency in the range.
- (3) The test result calculated as following:  
 Measurement Value = Reading Level + Correct Factor  
 Correct Factor = Insertion Loss + Cable Loss + Attenuator Factor (if use)  
 Margin Level = Measurement Value – Limit Value  
 Calculation example:

Reading Level		Correct Factor		Measurement Value
38.22	+	3.45	=	41.67

Measurement Value		Limit Value		Margin Level
41.67	-	60	=	-18.33

The following table is the setting of the receiver.

Receiver Parameter	Setting
Attenuation	10 dB
Start Frequency	0.15 MHz
Stop Frequency	30 MHz
IF Bandwidth	9 KHz

#### 3.2 TEST PROCEDURE

- a. The EUT was placed 0.8 m above the horizontal ground plane with the EUT being connected to the power mains through a line impedance stabilization network (LISN).  
 All other support equipment were powered from an additional LISN(s).  
 The LISN provides 50 Ohm/50uH of impedance for the measuring instrument.
- b. Interconnecting cables that hang closer than 40 cm to the ground plane shall be folded back and forth in the center forming a bundle to keep the cable above 40 cm.
- c. Excess I/O cables that are not connected to a peripheral shall be bundled in the center.  
 The end of the cable will be terminated, using the correct terminating impedance.  
 The overall length shall not exceed 1 m.
- d. The LISN is spaced at least 80 cm from the nearest part of the EUT chassis.
- e. For the actual test configuration, please refer to the related Item - EUT TEST PHOTO.

**NOTE:**

- (1) In the results, each reading is marked as Peak, QP or AVG per the detector used.  
 BW=9 kHz (6 dB Bandwidth)
- (2) All readings are Peak unless otherwise stated QP or AVG in column of Note. Both the QP and the AVG readings must be less than the limit for compliance.

#### 3.3 DEVIATION FROM TEST STANDARD

No deviation.

### 3.4 TEST SETUP

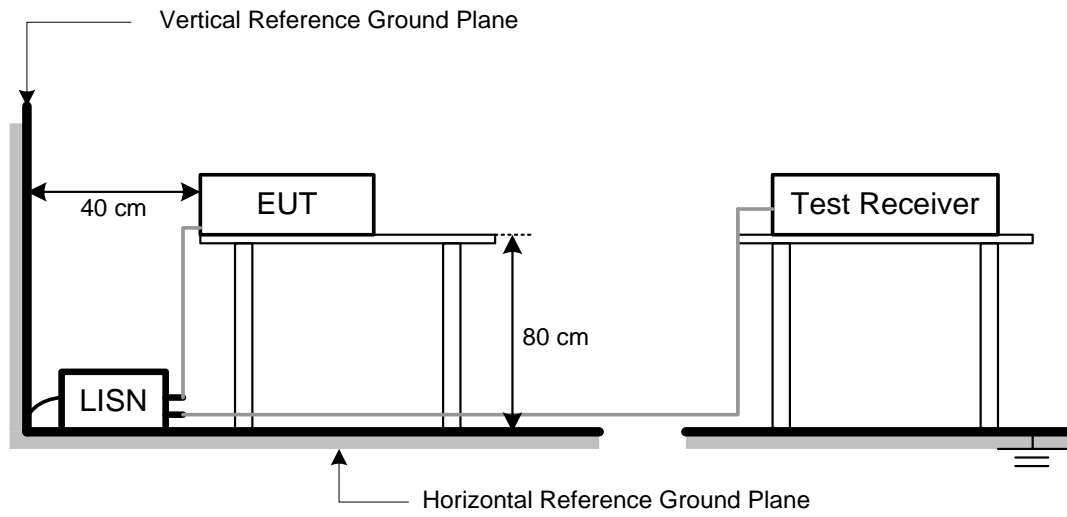

### 3.5 TEST RESULT

Please refer to the APPENDIX A.

## 4 RADIATED EMISSIONS TEST

### 4.1 LIMIT

In case the emission fall within the restricted band specified on 15.205, then the 15.209 limit in the table below has to be followed.

#### LIMITS OF RADIATED EMISSIONS MEASUREMENT (9 kHz to 1000 MHz)

Frequency (MHz)	Field Strength (microvolts/meter)	Measurement Distance (meters)
0.009~0.490	2400/F(KHz)	300
0.490~1.705	24000/F(KHz)	30
1.705~30.0	30	30
30~88	100	3
88~216	150	3
216~960	200	3
960~1000	500	3

#### LIMITS OF UNWANTED EMISSION OUT OF THE RESTRICTED BANDS

Frequency (MHz)	EIRP Limit (dBm)	Equivalent Field Strength at 3m (dBµV/m)
5150-5250	-27	68.3
5250-5350	-27	68.3
5470-5725	-27	68.3
5725-5850	-27 (NOTE 2)	68.3
	10 (NOTE 2)	105.3
	15.6 (NOTE 2)	110.9
	27 (NOTE 2)	122.3

#### NOTE:

(1) The following formula is used to convert the equipment isotropic radiated power (eirp) to field strength:

$$E = \frac{1000000\sqrt{30P}}{3} \mu\text{V/m, where P is the eirp (Watts)}$$

(2) According to FCC 16-24, All emissions shall be limited to a level of -27 dBm/MHz at 75 MHz or more above or below the band edge increasing linearly to 10 dBm/MHz at 25 MHz above or below the band edge, and from 25 MHz above or below the band edge increasing linearly to a level of 15.6 dBm/MHz at 5 MHz above or below the band edge, and from 5 MHz above or below the band edge increasing linearly to a level of 27 dBm/MHz at the band edge.

(3) The test result calculated as following:

Measurement Value = Reading Level + Correct Factor

Correct Factor = Antenna Factor + Cable Loss - Amplifier Gain(if use)

Margin Level = Measurement Value - Limit Value

Calculation example:

Reading Level		Correct Factor		Measurement Value
36.23	+	-11.97	=	24.26

Measurement Value		Limit Value		Margin Level
24.26	-	40	=	-15.74

Spectrum Parameter	Setting
Attenuation	Auto
Start Frequency	1000 MHz
Stop Frequency	10th carrier harmonic
RBW / VBW (Emission in restricted band)	1MHz / 3MHz for Peak, 1MHz / 1/T for Average

Spectrum Parameter	Setting
Attenuation	Auto
Start ~ Stop Frequency	9KHz~90KHz for PK/AVG detector
Start ~ Stop Frequency	90KHz~110KHz for QP detector
Start ~ Stop Frequency	110KHz~490KHz for PK/AVG detector
Start ~ Stop Frequency	490KHz~30MHz for QP detector
Start ~ Stop Frequency	30MHz~1000MHz for QP detector

#### 4.2 TEST PROCEDURE

- a. The measuring distance of 3 m shall be used for measurements. The EUT was placed on the top of a rotating table 0.8 meter above the ground at a 3 meter semi-anechoic chamber. The table was rotated 360 degrees to determine the position of the highest radiation.(below 1GHz)
- b. The measuring distance of 3 m shall be used for measurements. The EUT was placed on the top of a rotating table 1.5 meter above the ground at a 3 meter semi-anechoic chamber. The table was rotated 360 degrees to determine the position of the highest radiation.(above 1GHz)
- c. The height of the equipment or of the substitution antenna shall be 0.8 m or 1.5 m, the height of the test antenna shall vary between 1 m to 4 m. Both horizontal and vertical polarizations of the antenna are set to make the measurement.
- d. For each suspected emission, the EUT was arranged to its worst case and then the antenna was tuned to heights find the maximum reading (used Bore sight function).
- e. The receiver system was set to peak and average detect function and specified bandwidth with maximum hold mode when the test frequency is above 1GHz.
- f. The initial step in collecting radiated emission data is a receiver peak detector mode pre-scanning the measurement frequency range. Significant peaks are then marked and then Quasi Peak detector mode re-measured.
- g. All readings are Peak unless otherwise stated QP in column of Note. Peak denotes that the Peak reading compliance with the QP Limits and then QP Mode measurement didn't perform. (below 1GHz)
- h. All readings are Peak Mode value unless otherwise stated AVG in column of Note. If the Peak Mode Measured value compliance with the Peak Limits and lower than AVG Limits, the EUT shall be deemed to meet both Peak & AVG Limits and then only Peak Mode was measured, but AVG Mode didn't perform. (above 1GHz)
- i. For the actual test configuration, please refer to the related Item – EUT TEST PHOTO.

#### 4.3 DEVIATION FROM TEST STANDARD

No deviation.



## 4.4 TEST SETUP

9 kHz to 30 MHz

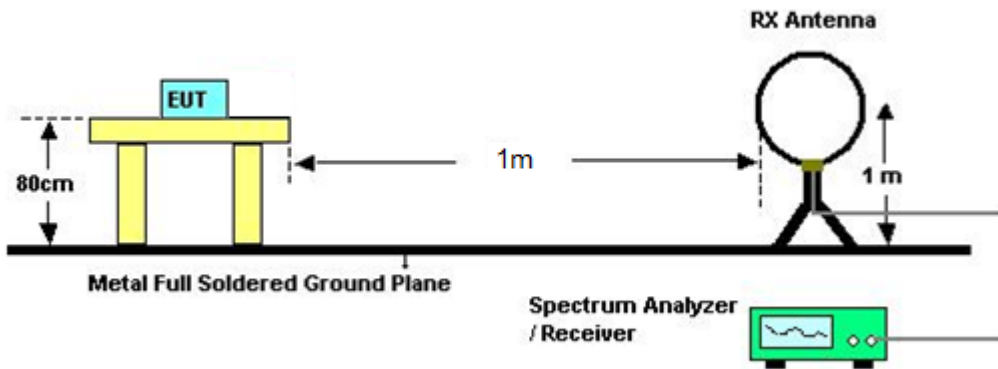

30 MHz to 1 GHz

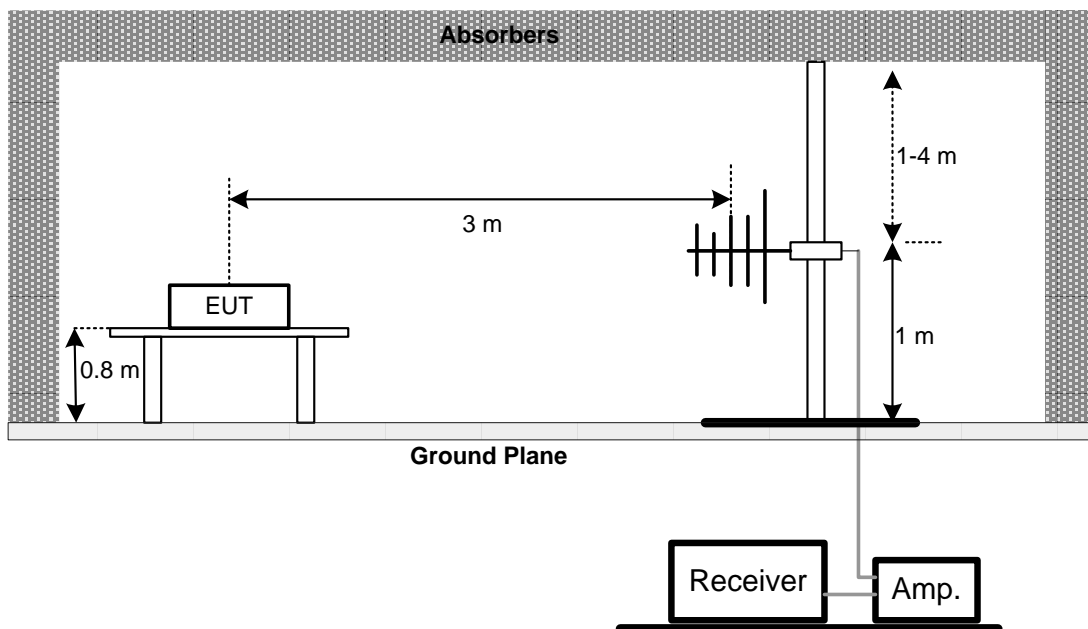

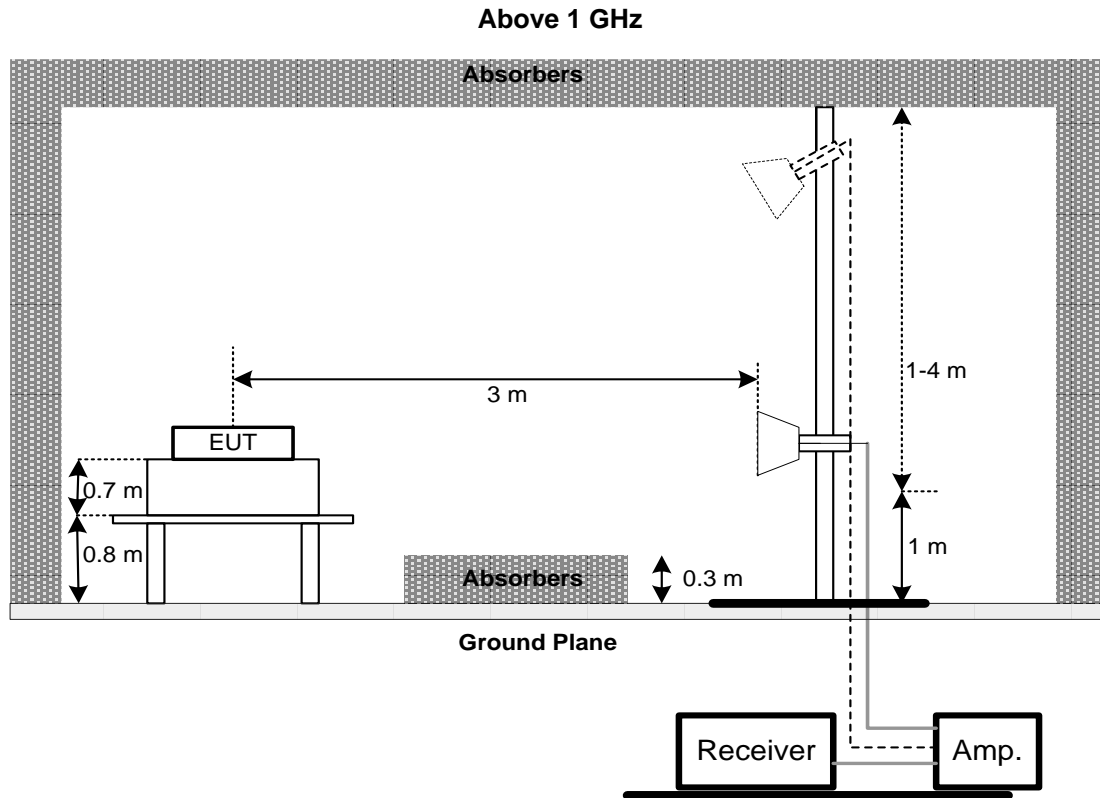

#### 4.5 EUT OPERATING CONDITIONS

The EUT was programmed to be in continuously transmitting mode.

#### 4.6 TEST RESULT – BELOW 30 MHZ

There were no emissions found below 30 MHz within 20 dB of the limit.

#### 4.7 TEST RESULT – 30 MHZ TO 1 GHZ

Please refer to the APPENDIX B.

#### 4.8 TEST RESULT – ABOVE 1 GHZ

Please refer to the APPENDIX C.

#### NOTE:

- (1) No limit: This is fundamental signal, the judgment is not applicable. For fundamental signal judgment was referred to Peak output test.

## 5 MAXIMUM E.I.R.P. TEST

### 5.1 LIMIT

Section	Equipment Category	Maximum e.i.r.p. Limit
15.407(a)	Indoor access point	36
	Subordinate device	36
	Client devices	30

### 5.2 TEST PROCEDURE

- a. The EUT was directly connected to the power meter and antenna output port as show in the block diagram below.
- b. Method PM-G (Measurement using a gated RF average power meter):  
 Measurements may be performed using a wideband gated RF power meter provided that the gateparameters are adjusted such that the power is measured only when the EUT is transmitting at itsmaximum power control level. Since the measurement is made only during the ON time of thetransmitter, no duty cycle correction factor is required.

### 5.3 DEVIATION FROM TEST STANDARD

No deviation.

### 5.4 TEST SETUP

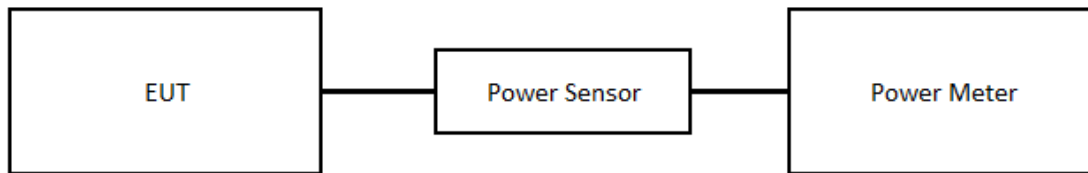

### 5.5 EUT OPERATING CONDITIONS

The EUT was programmed to be in continuously transmitting mode.

### 5.6 TEST RESULT

Please refer to the APPENDIX D

## 6 LIST OF MEASURING EQUIPMENTS

AC Power Line Conducted Emissions						
Item	Kind of Equipment	Manufacturer	Type No.	Serial No.	Calibrated Date	Calibrated Until
1	TWO-LINE V-NETWORK	R&S	ENV216	101521	2022/9/28	2023/9/27
2	Test Cable	EMCI	EMCCFD300-BM-BMR-5000	220331	2022/3/31	2023/3/30
3	EMI Test Receiver	R&S	ESR 7	101433	2022/11/16	2023/11/15
4	Measurement Software	EZ	EZ EMC (Version NB-03A1-01)	N/A	N/A	N/A

Radiated Emissions						
Item	Kind of Equipment	Manufacturer	Type No.	Serial No.	Calibrated Date	Calibrated Until
1	Preamplifier	EMCI	EMC330N	980850	2022/9/19	2023/9/18
2	Preamplifier	EMCI	EMC118A45SE	980819	2022/3/8	2023/3/7
3	Preamplifier	EMCI	EMC184045SE	980882	2022/2/9	2023/2/8
4	Preamplifier	EMCI	EMC001340	980579	2022/9/30	2023/9/29
5	Test Cable	EMCI	EMC104-SM-SM-1000	220319	2022/3/15	2023/3/14
6	Test Cable	EMCI	EMC104-SM-SM-3000	220322	2022/3/15	2023/3/14
7	Test Cable	EMCI	EMC104-SM-SM-7000	220324	2022/3/15	2023/3/14
8	EXA Signal Analyzer	keysight	N9020B	MY57120120	2022/3/7	2023/3/6
9	Loop Ant	Electro-Metrics	EMCI-LPA600	291	2022/9/19	2023/9/18
10	Horn Antenna	RFSPIN	DRH18-E	211202A18EN	2022/5/18	2023/5/17
11	Horn Ant	Schwarzbeck	BBHA 9170D	1136	2022/5/18	2023/5/17
12	Log-bicon Antenna	Schwarzbeck	VULB9168	1369	2022/5/20	2023/5/19
13	6dB Attenuator	EMCI	EMCI-N-6-06	AT-N0625	2022/5/20	2023/5/19
14	Test Cable	EMCI	EMC101G-KM-KM-3000	220329	2022/3/15	2023/3/14
15	Test Cable	EMCI	EMC102-KM-KM-1000	220327	2022/3/15	2023/3/14
16	Measurement Software	EZ	EZ EMC (Version NB-03A1-01)	N/A	N/A	N/A

Maximum E.I.R.P.						
Item	Kind of Equipment	Manufacturer	Type No.	Serial No.	Calibrated Date	Calibrated Until
1	Power Meter	Anritsu	ML2495A	1128008	2022/6/1	2023/5/31
2	Power Sensor	Anritsu	MA2411B	1126001	2022/6/1	2023/5/31

Remark: "N/A" denotes no model name, no serial no. or no calibration specified.  
All calibration period of equipment list is one year.

**7 EUT TEST PHOTO**

Please refer to document Appendix No.: TP-2212C001-1 (APPENDIX-TEST PHOTOS).

**8 EUT PHOTOS**

Please refer to document Appendix No.: EP-2212C001-1 (APPENDIX-EUT PHOTOS).

## **APPENDIX A AC POWER LINE CONDUCTED EMISSIONS**

Test Mode	Normal	Tested Date	2023/1/6
Test Frequency	-	Phase	Line

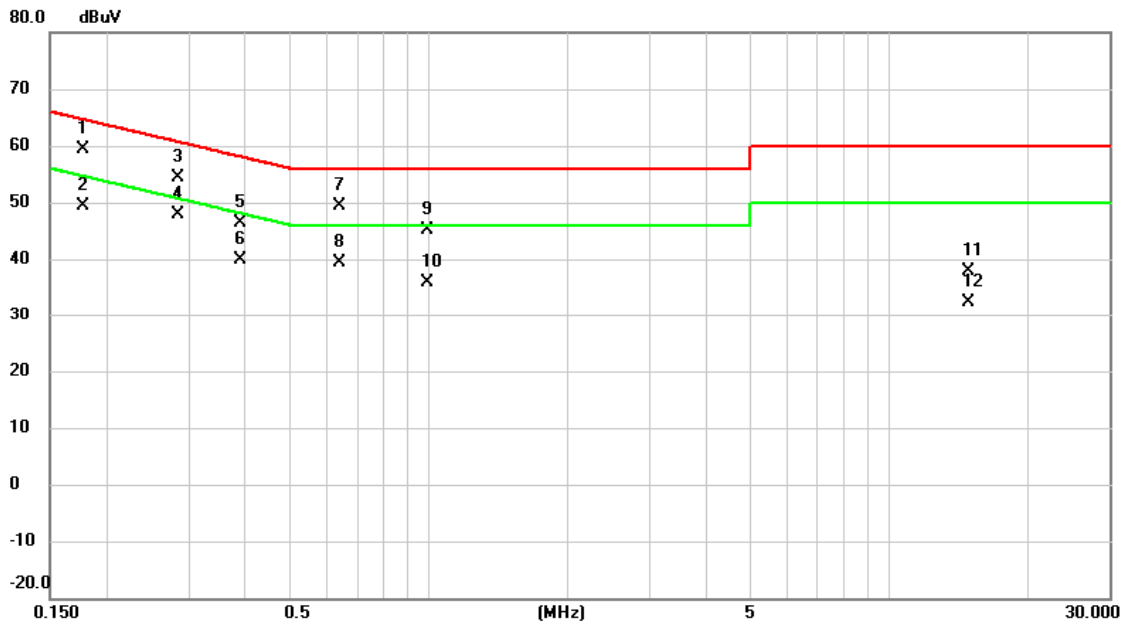

No.	Mk.	Freq. MHz	Reading Level dBuV	Correct Factor dB	Measure- ment dBuV	Limit dBuV	Margin dB	Detector	Comment
1		0.1770	49.65	9.63	59.28	64.63	-5.35	QP	
2		0.1770	39.72	9.63	49.35	54.63	-5.28	AVG	
3		0.2850	44.70	9.63	54.33	60.67	-6.34	QP	
4	*	0.2850	38.24	9.63	47.87	50.67	-2.80	AVG	
5		0.3907	36.82	9.63	46.45	58.05	-11.60	QP	
6		0.3907	30.37	9.63	40.00	48.05	-8.05	AVG	
7		0.6405	39.69	9.64	49.33	56.00	-6.67	QP	
8		0.6405	29.65	9.64	39.29	46.00	-6.71	AVG	
9		0.9960	35.34	9.67	45.01	56.00	-10.99	QP	
10		0.9960	26.10	9.67	35.77	46.00	-10.23	AVG	
11		14.8830	27.99	9.89	37.88	60.00	-22.12	QP	
12		14.8830	22.40	9.89	32.29	50.00	-17.71	AVG	

**REMARKS:**

- (1) Measurement Value = Reading Level + Correct Factor.
- (2) Margin Level = Measurement Value - Limit Value.

Test Mode	Normal	Tested Date	2023/1/6
Test Frequency	-	Phase	Neutral

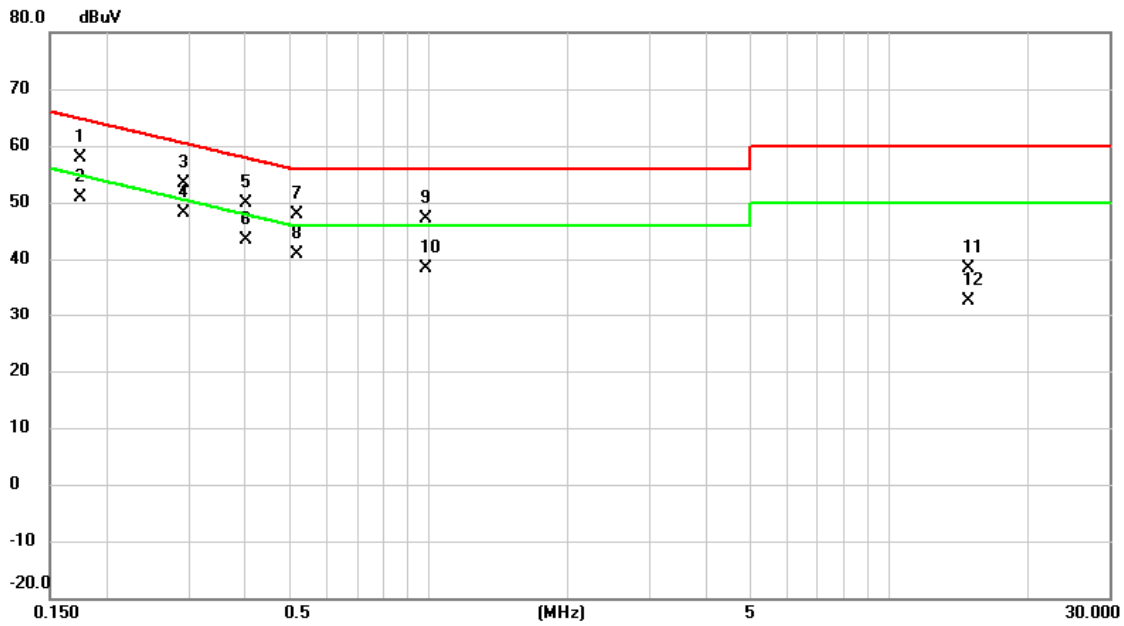

No.	Mk.	Freq. MHz	Reading Level dBuV	Correct Factor dB	Measure- ment dBuV	Limit dBuV	Margin dB	Detector	Comment
1		0.1748	48.22	9.65	57.87	64.73	-6.86	QP	
2		0.1748	41.29	9.65	50.94	54.73	-3.79	AVG	
3		0.2917	43.65	9.64	53.29	60.48	-7.19	QP	
4	*	0.2917	38.42	9.64	48.06	50.48	-2.42	AVG	
5		0.4020	40.26	9.64	49.90	57.81	-7.91	QP	
6		0.4020	33.83	9.64	43.47	47.81	-4.34	AVG	
7		0.5167	38.22	9.64	47.86	56.00	-8.14	QP	
8		0.5167	31.16	9.64	40.80	46.00	-5.20	AVG	
9		0.9870	37.34	9.68	47.02	56.00	-8.98	QP	
10		0.9870	28.65	9.68	38.33	46.00	-7.67	AVG	
11		14.8853	28.53	9.97	38.50	60.00	-21.50	QP	
12		14.8853	22.73	9.97	32.70	50.00	-17.30	AVG	

**REMARKS:**

- (1) Measurement Value = Reading Level + Correct Factor.
- (2) Margin Level = Measurement Value - Limit Value.



Test Mode	Idle	Tested Date	2023/1/6
Test Frequency	-	Phase	Line

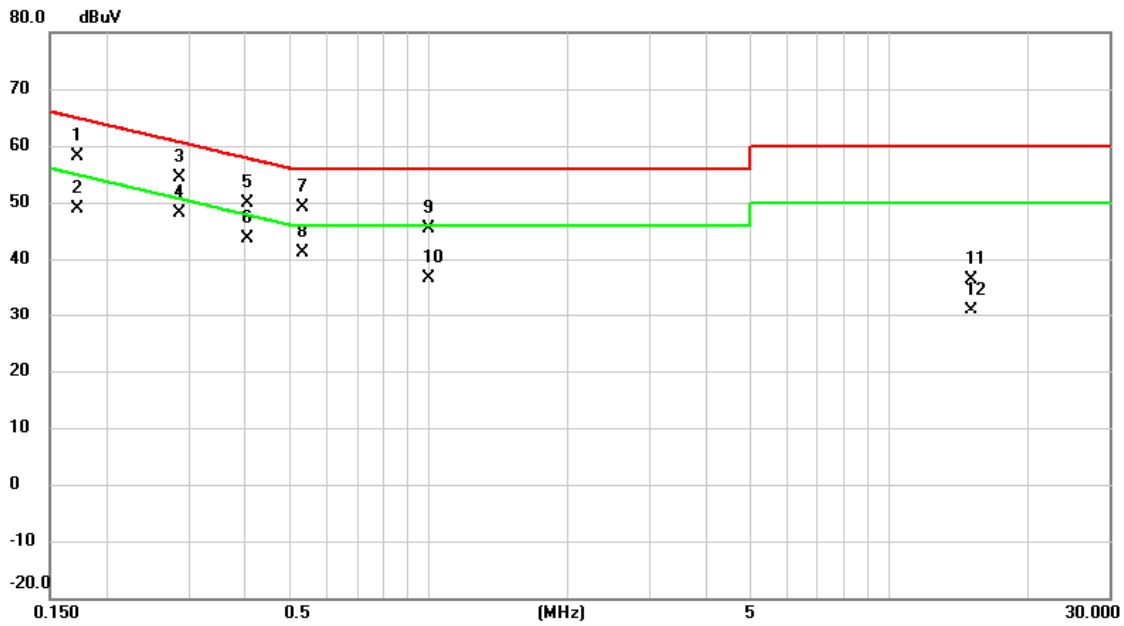

No.	Mk.	Freq. MHz	Reading Level dBuV	Correct Factor dB	Measure- ment dBuV	Limit dBuV	Margin dB	Detector	Comment
1		0.1725	48.52	9.64	58.16	64.84	-6.68	QP	
2		0.1725	39.22	9.64	48.86	54.84	-5.98	AVG	
3		0.2872	44.76	9.63	54.39	60.60	-6.21	QP	
4	*	0.2872	38.54	9.63	48.17	50.60	-2.43	AVG	
5		0.4042	40.28	9.63	49.91	57.77	-7.86	QP	
6		0.4042	33.88	9.63	43.51	47.77	-4.26	AVG	
7		0.5325	39.43	9.63	49.06	56.00	-6.94	QP	
8		0.5325	31.52	9.63	41.15	46.00	-4.85	AVG	
9		1.0005	35.62	9.67	45.29	56.00	-10.71	QP	
10		1.0005	27.04	9.67	36.71	46.00	-9.29	AVG	
11		15.0833	26.54	9.90	36.44	60.00	-23.56	QP	
12		15.0833	20.95	9.90	30.85	50.00	-19.15	AVG	

**REMARKS:**

(1) Measurement Value = Reading Level + Correct Factor.

(2) Margin Level = Measurement Value - Limit Value.

Test Mode	Idle	Tested Date	2023/1/6
Test Frequency	-	Phase	Neutral

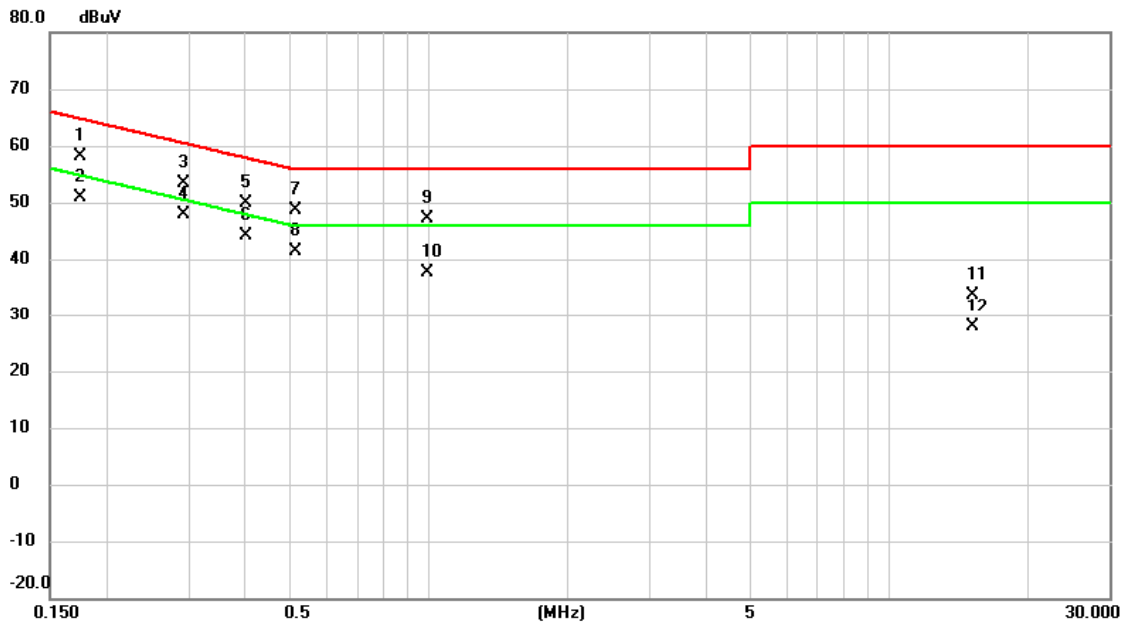

No.	Mk.	Freq. MHz	Reading Level dBuV	Correct Factor dB	Measure- ment dBuV	Limit dBuV	Margin dB	Detector	Comment
1		0.1748	48.52	9.65	58.17	64.73	-6.56	QP	
2		0.1748	41.23	9.65	50.88	54.73	-3.85	AVG	
3		0.2917	43.65	9.64	53.29	60.48	-7.19	QP	
4	*	0.2917	38.19	9.64	47.83	50.48	-2.65	AVG	
5		0.4020	40.23	9.64	49.87	57.81	-7.94	QP	
6		0.4020	34.52	9.64	44.16	47.81	-3.65	AVG	
7		0.5144	38.91	9.64	48.55	56.00	-7.45	QP	
8		0.5144	31.62	9.64	41.26	46.00	-4.74	AVG	
9		0.9892	37.42	9.68	47.10	56.00	-8.90	QP	
10		0.9892	28.06	9.68	37.74	46.00	-8.26	AVG	
11		15.1463	23.61	9.98	33.59	60.00	-26.41	QP	
12		15.1463	17.83	9.98	27.81	50.00	-22.19	AVG	

**REMARKS:**

(1) Measurement Value = Reading Level + Correct Factor.

(2) Margin Level = Measurement Value - Limit Value.

## **APPENDIX B RADIATED EMISSIONS - 30 MHZ TO 1 GHZ**

Test Mode	IEEE 802.11ax (HE160)	Test Date	2023/2/1
Test Frequency	5815MHz	Polarization	Vertical
Temp	23°C	Hum.	59%

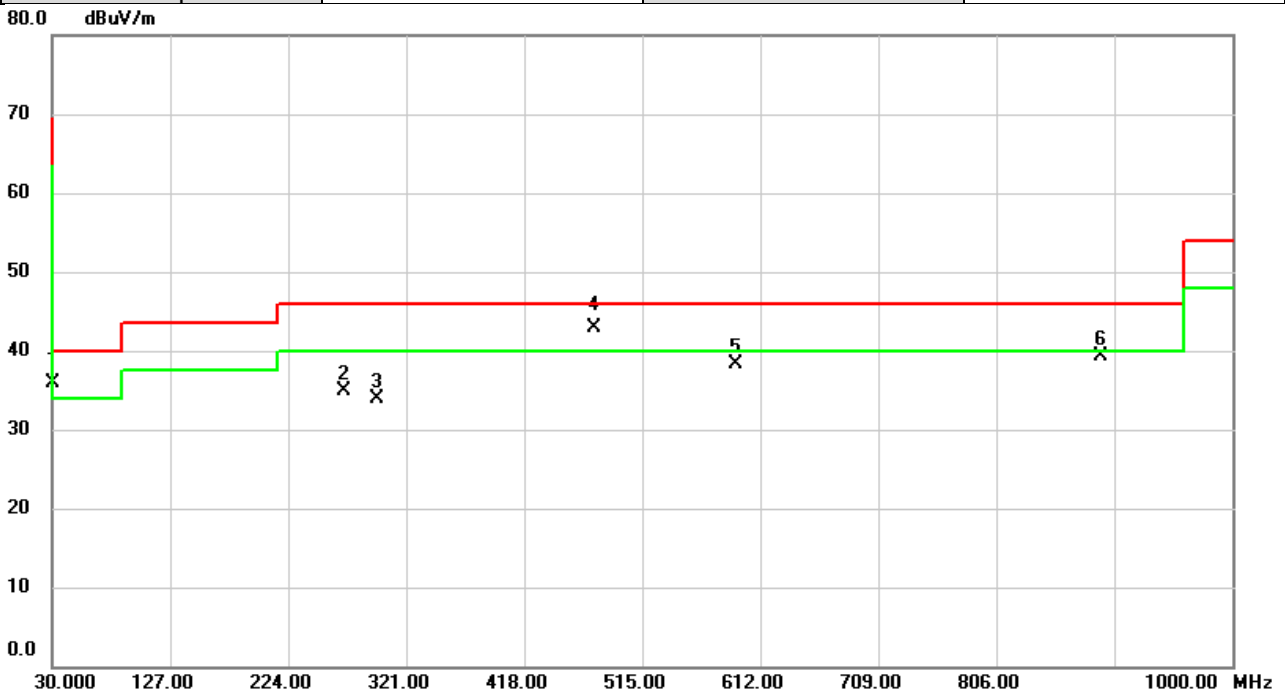

No.	Mk.	Freq.	Reading Level	Correct Factor	Measurement	Limit	Over	Detector	Comment
		MHz	dBuV	dB	dBuV/m	dBuV/m	dB		
1	!	30.9710	48.62	-12.73	35.89	40.00	-4.11	QP	
2		270.5348	47.08	-12.21	34.87	46.00	-11.13	peak	
3		297.0170	45.40	-11.51	33.89	46.00	-12.11	peak	
4	*	475.6724	49.81	-6.94	42.87	46.00	-3.13	QP	
5		591.4328	42.81	-4.42	38.39	46.00	-7.61	peak	
6		891.3674	39.33	-0.03	39.30	46.00	-6.70	peak	

**REMARKS:**

- (1) Measurement Value = Reading Level + Correct Factor.
- (2) Margin Level = Measurement Value - Limit Value.

Test Mode	IEEE 802.11ax (HE160)	Test Date	2023/2/1
Test Frequency	5815MHz	Polarization	Horizontal
Temp	23°C	Hum.	59%

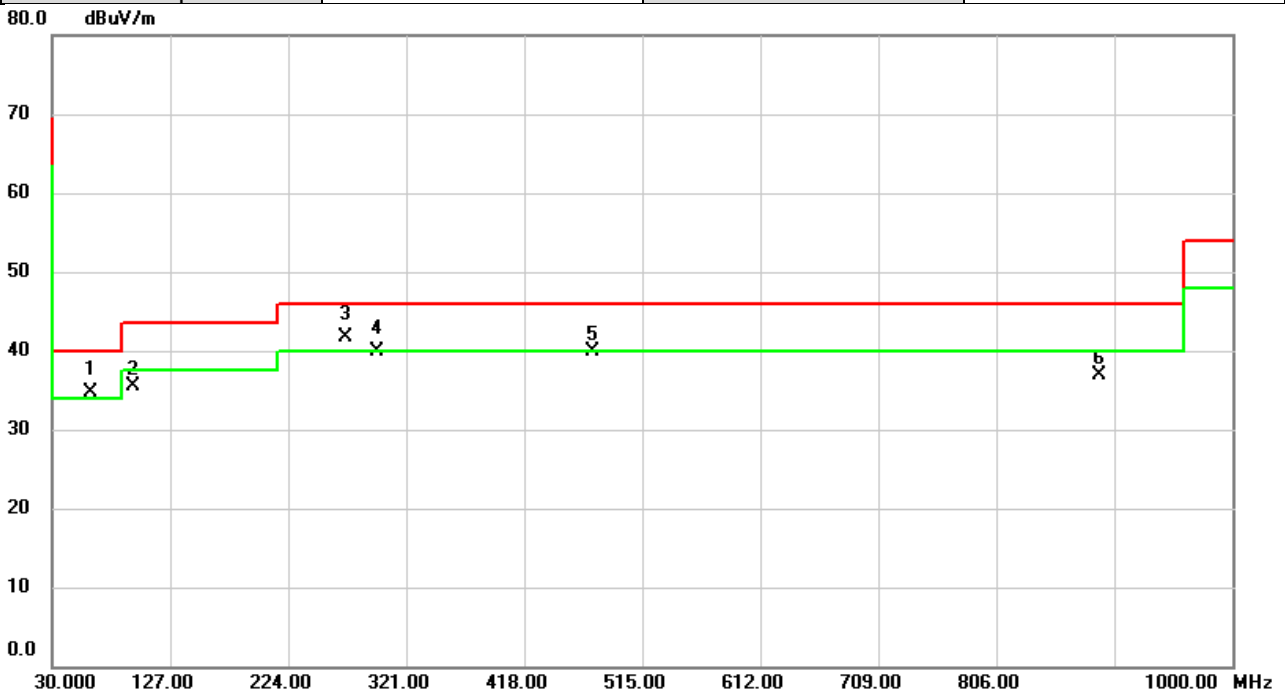

No.	Mk.	Freq.	Reading Level	Correct Factor	Measurement	Limit	Over	Detector	Comment
		MHz	dBuV	dB	dBuV/m	dBuV/m	dB		
1	!	62.1368	47.14	-12.44	34.70	40.00	-5.30	QP	
2		96.4464	52.23	-16.76	35.47	43.50	-8.03	peak	
3	*	270.7127	53.97	-12.21	41.76	46.00	-4.24	QP	
4		297.1283	51.47	-11.51	39.96	46.00	-6.04	QP	
5		474.6132	46.90	-6.98	39.92	46.00	-6.08	peak	
6		891.2437	36.88	-0.03	36.85	46.00	-9.15	peak	

**REMARKS:**

- (1) Measurement Value = Reading Level + Correct Factor.
- (2) Margin Level = Measurement Value - Limit Value.

## **APPENDIX C    RADIATED EMISSIONS - ABOVE 1 GHZ**

Test Mode	IEEE 802.11a	Test Date	2023/2/3
Test Frequency	5845MHz	Polarization	Vertical
Temp	23°C	Hum.	59%

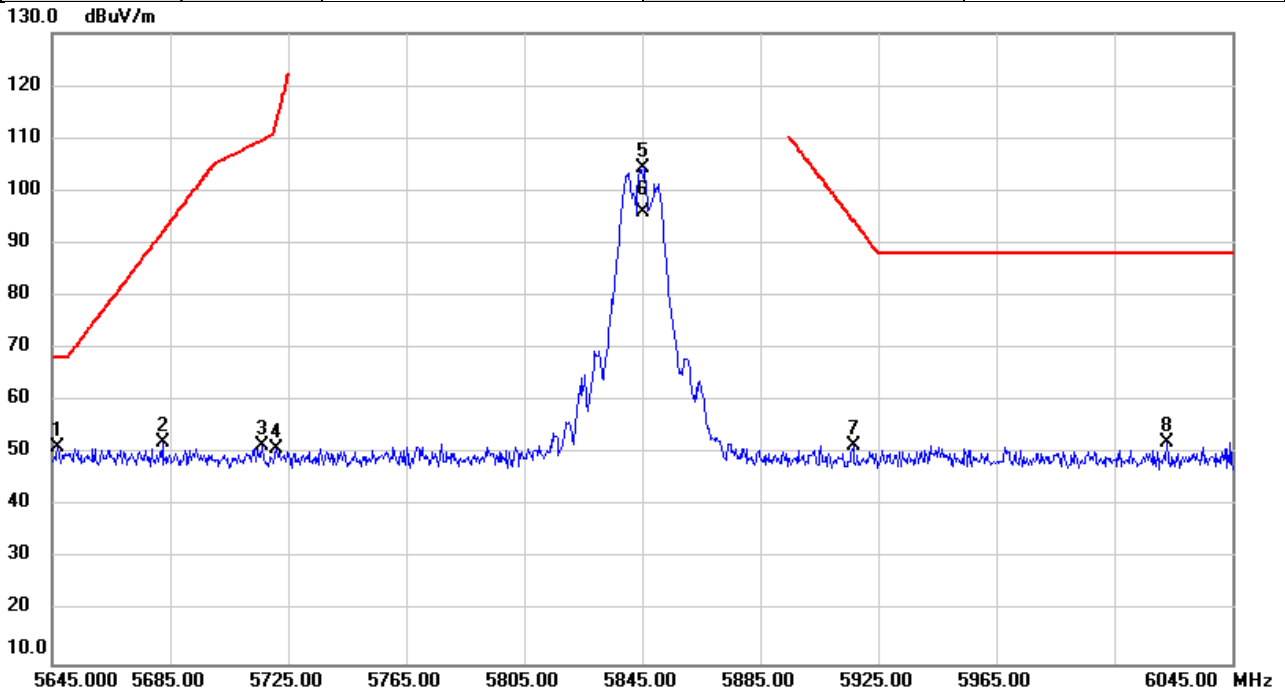

No.	Mk.	Freq.	Reading Level	Correct Factor	Measurement	Limit	Over	Detector	Comment
		MHz	dBuV	dB	dBuV/m	dBuV/m	dB		
1	*	5646.827	49.43	1.79	51.22	68.20	-16.98	peak	
2		5682.507	50.30	1.86	52.16	92.26	-40.10	peak	
3		5716.000	49.67	1.92	51.59	109.68	-58.09	peak	
4		5721.160	48.95	1.93	50.88	113.44	-62.56	peak	
5		5845.000	102.25	2.19	104.44			peak	No Limit
6		5845.000	93.72	2.19	95.91			AVG	No Limit
7		5916.493	49.29	2.33	51.62	94.44	-42.82	peak	
8		6022.813	49.68	2.61	52.29	88.20	-35.91	peak	

**REMARKS:**

- (1) Measurement Value = Reading Level + Correct Factor.
- (2) Margin Level = Measurement Value - Limit Value.

Test Mode	IEEE 802.11ac (VHT80)	Test Date	2023/2/1
Test Frequency	5855MHz	Polarization	Vertical
Temp	23°C	Hum.	59%

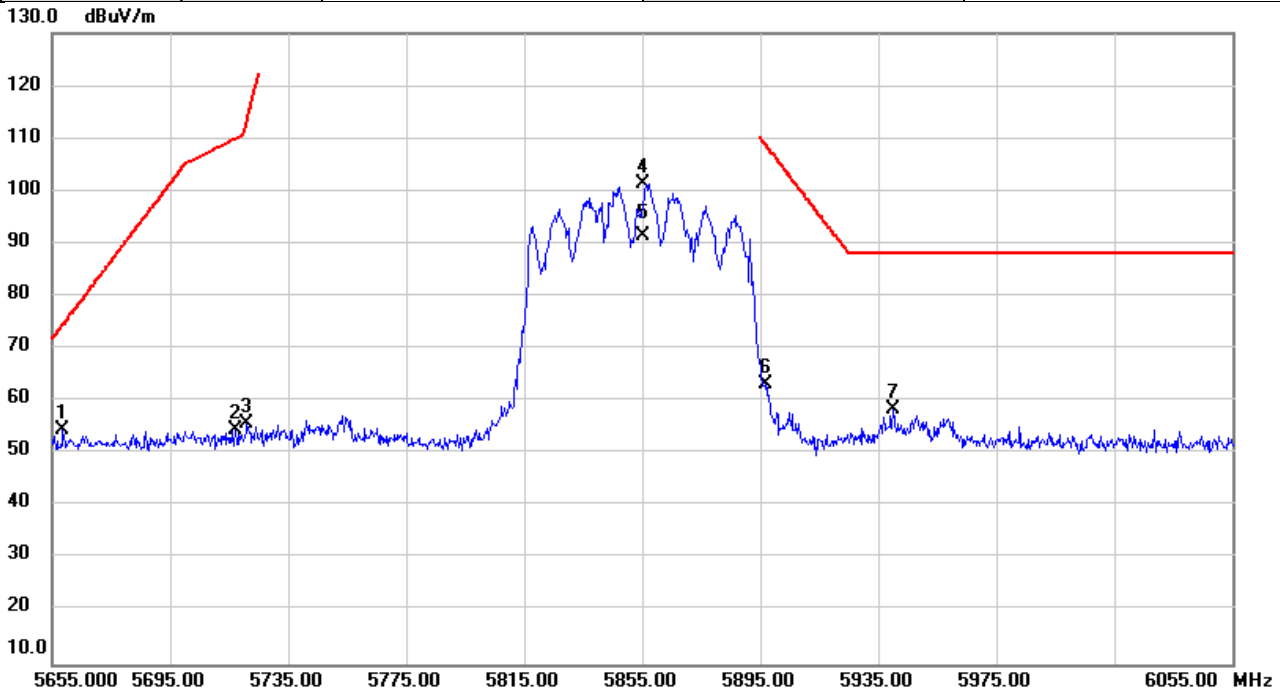

No.	Mk.	Freq.	Reading Level	Correct Factor	Measurement	Limit	Over	Detector	Comment
		MHz	dBuV	dB	dBuV/m	dBuV/m	dB		
1	*	5658.720	52.61	1.81	54.42	74.65	-20.23	peak	
2		5717.253	52.53	1.92	54.45	110.03	-55.58	peak	
3		5721.040	53.78	1.93	55.71	113.17	-57.46	peak	
4		5855.000	99.06	2.21	101.27			peak	No Limit
5		5855.000	89.29	2.21	91.50			AVG	No Limit
6		5896.933	60.88	2.30	63.18	108.78	-45.60	peak	
7		5940.107	56.17	2.38	58.55	88.20	-29.65	peak	

**REMARKS:**

- (1) Measurement Value = Reading Level + Correct Factor.
- (2) Margin Level = Measurement Value - Limit Value.



Test Mode	IEEE 802.11ax (HE160)	Test Date	2023/2/1
Test Frequency	5815MHz	Polarization	Vertical
Temp	23°C	Hum.	59%

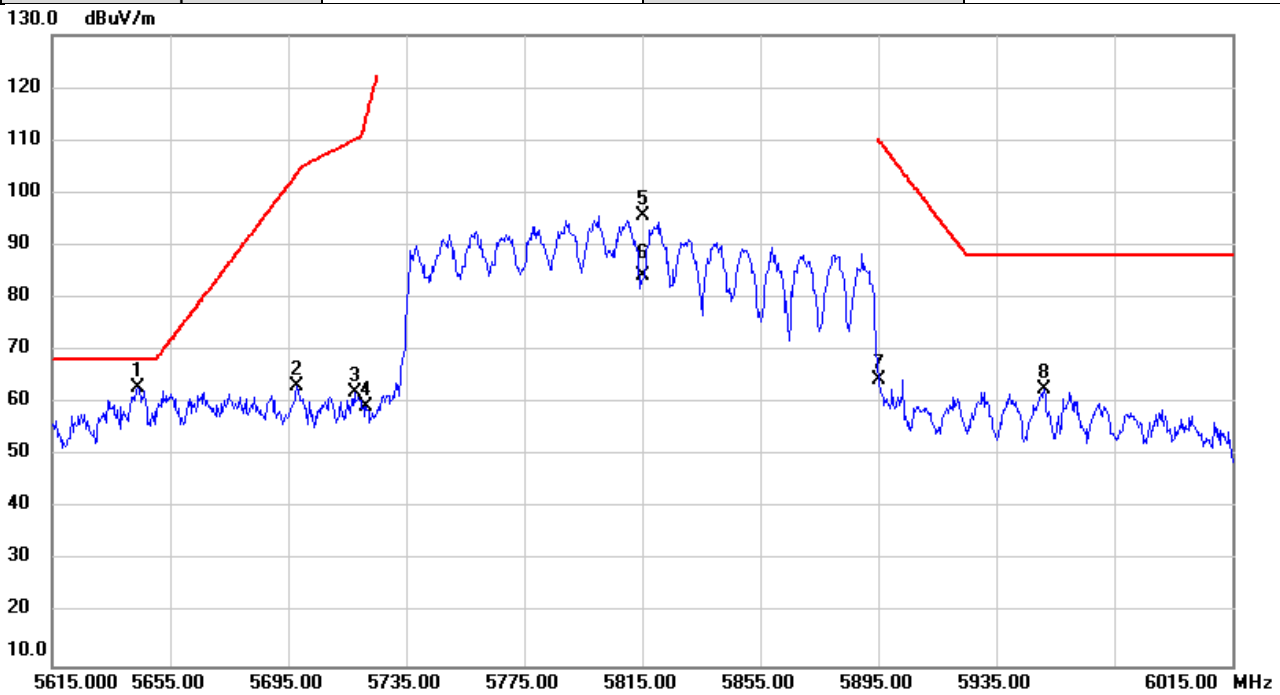

No.	Mk.	Freq.	Reading Level	Correct Factor	Measurement	Limit	Over	Detector	Comment
		MHz	dBuV	dB	dBuV/m	dBuV/m	dB		
1	*	5644.107	61.14	1.78	62.92	68.20	-5.28	peak	
2		5698.067	61.32	1.89	63.21	103.77	-40.56	peak	
3		5717.587	59.99	1.92	61.91	110.12	-48.21	peak	
4		5721.600	57.55	1.93	59.48	114.45	-54.97	peak	
5		5815.000	93.42	2.13	95.55			peak	No Limit
6		5815.000	82.26	2.13	84.39			AVG	No Limit
7		5895.000	62.14	2.29	64.43	110.20	-45.77	peak	
8		5951.067	60.31	2.40	62.71	88.20	-25.49	peak	

**REMARKS:**

- (1) Measurement Value = Reading Level + Correct Factor.
- (2) Margin Level = Measurement Value - Limit Value.

Test Mode	IEEE 802.11a	Test Date	2023/2/1
Test Frequency	5845MHz	Polarization	Vertical
Temp	23°C	Hum.	59%

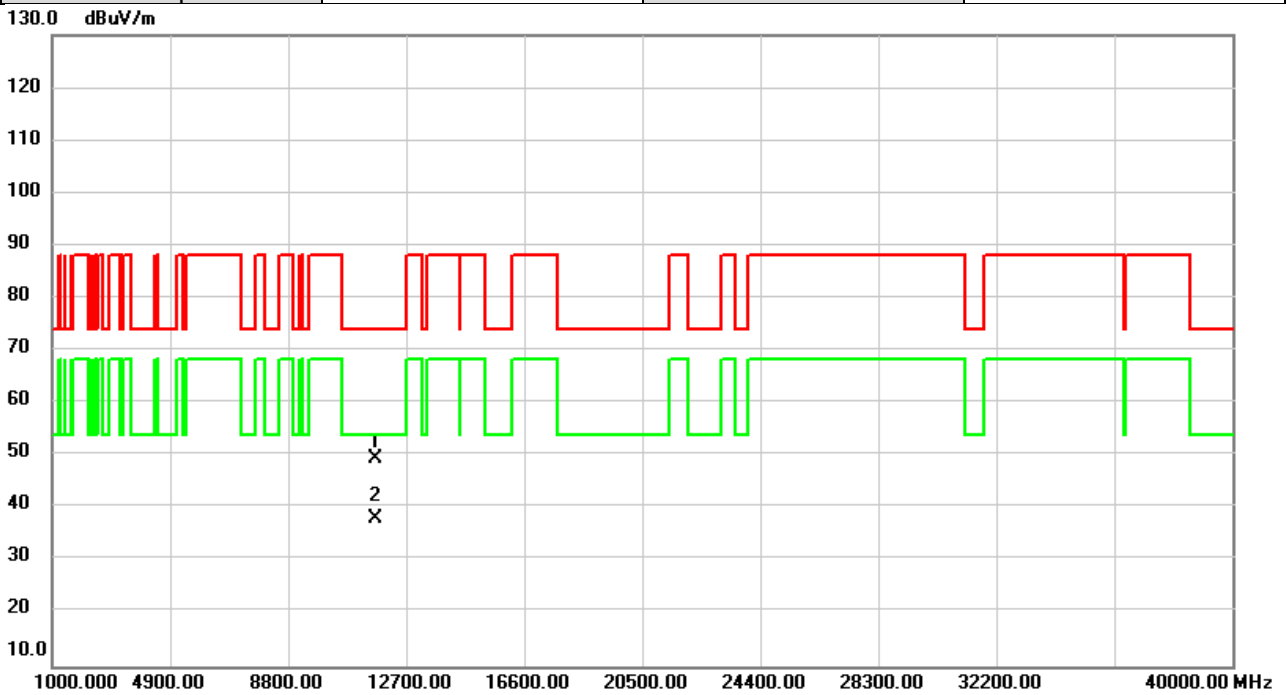

No.	Mk.	Freq.	Reading Level	Correct Factor	Measurement	Limit	Over	Detector	Comment
		MHz	dBuV	dB	dBuV/m	dBuV/m	dB		
1		11690.00	43.07	6.39	49.46	74.00	-24.54	peak	
2	*	11690.00	31.56	6.39	37.95	54.00	-16.05	AVG	

**REMARKS:**

- (1) Measurement Value = Reading Level + Correct Factor.
- (2) Margin Level = Measurement Value - Limit Value.

Test Mode	IEEE 802.11a	Test Date	2023/2/1
Test Frequency	5845MHz	Polarization	Horizontal
Temp	23°C	Hum.	59%

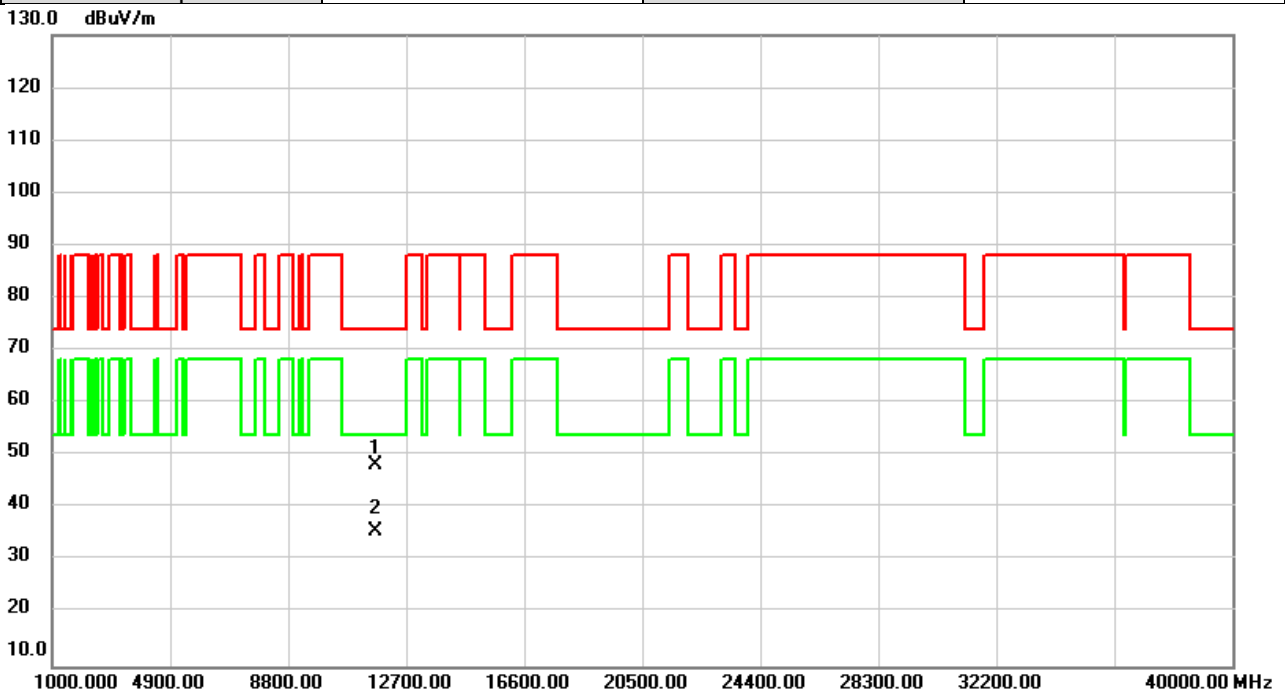

No.	Mk.	Freq. MHz	Reading Level dBuV	Correct Factor dB	Measure- ment dBuV/m	Limit dBuV/m	Over dB	Detector	Comment
1		11690.00	41.85	6.39	48.24	74.00	-25.76	peak	
2	*	11690.00	29.37	6.39	35.76	54.00	-18.24	AVG	

**REMARKS:**

- (1) Measurement Value = Reading Level + Correct Factor.
- (2) Margin Level = Measurement Value - Limit Value.

Test Mode	IEEE 802.11ac (VHT80)	Test Date	2023/2/1
Test Frequency	5855MHz	Polarization	Vertical
Temp	23°C	Hum.	59%

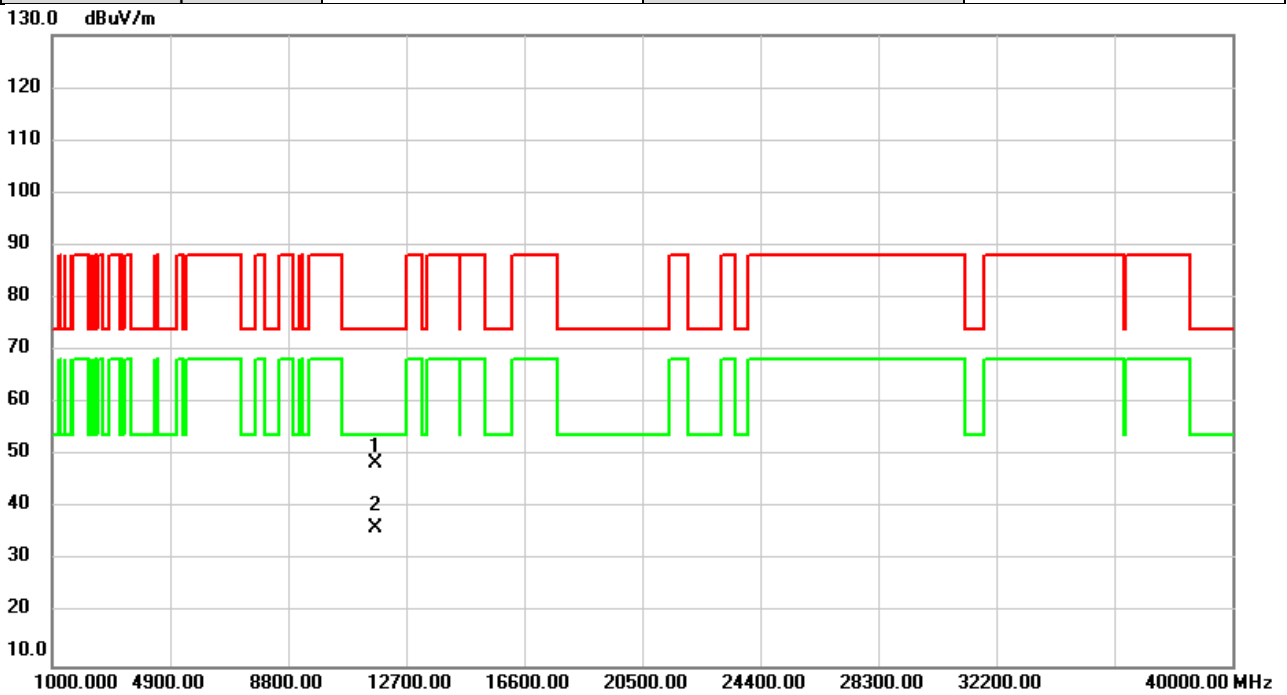

No.	Mk.	Freq.	Reading Level	Correct Factor	Measurement	Limit	Over	Detector	Comment
		MHz	dBuV	dB	dBuV/m	dBuV/m	dB		
1		11710.00	42.25	6.41	48.66	74.00	-25.34	peak	
2	*	11710.00	29.96	6.41	36.37	54.00	-17.63	AVG	

**REMARKS:**

- (1) Measurement Value = Reading Level + Correct Factor.
- (2) Margin Level = Measurement Value - Limit Value.

Test Mode	IEEE 802.11ac (VHT80)	Test Date	2023/2/1
Test Frequency	5855MHz	Polarization	Horizontal
Temp	23°C	Hum.	59%

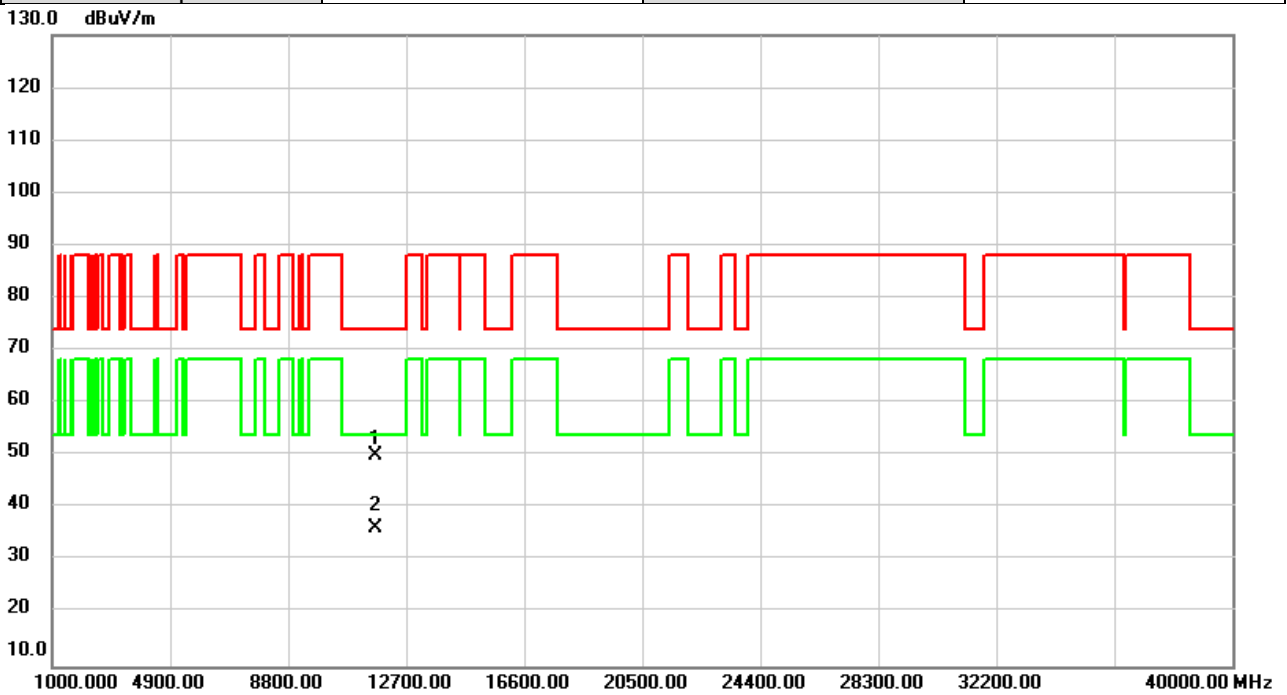

No.	Mk.	Freq.	Reading Level	Correct Factor	Measurement	Limit	Over	Detector	Comment
		MHz	dBuV	dB	dBuV/m	dBuV/m	dB		
1		11710.00	43.51	6.41	49.92	74.00	-24.08	peak	
2	*	11710.00	29.80	6.41	36.21	54.00	-17.79	AVG	

**REMARKS:**

- (1) Measurement Value = Reading Level + Correct Factor.
- (2) Margin Level = Measurement Value - Limit Value.

Test Mode	IEEE 802.11ax (HE160)	Test Date	2023/2/1
Test Frequency	5815MHz	Polarization	Vertical
Temp	23°C	Hum.	59%

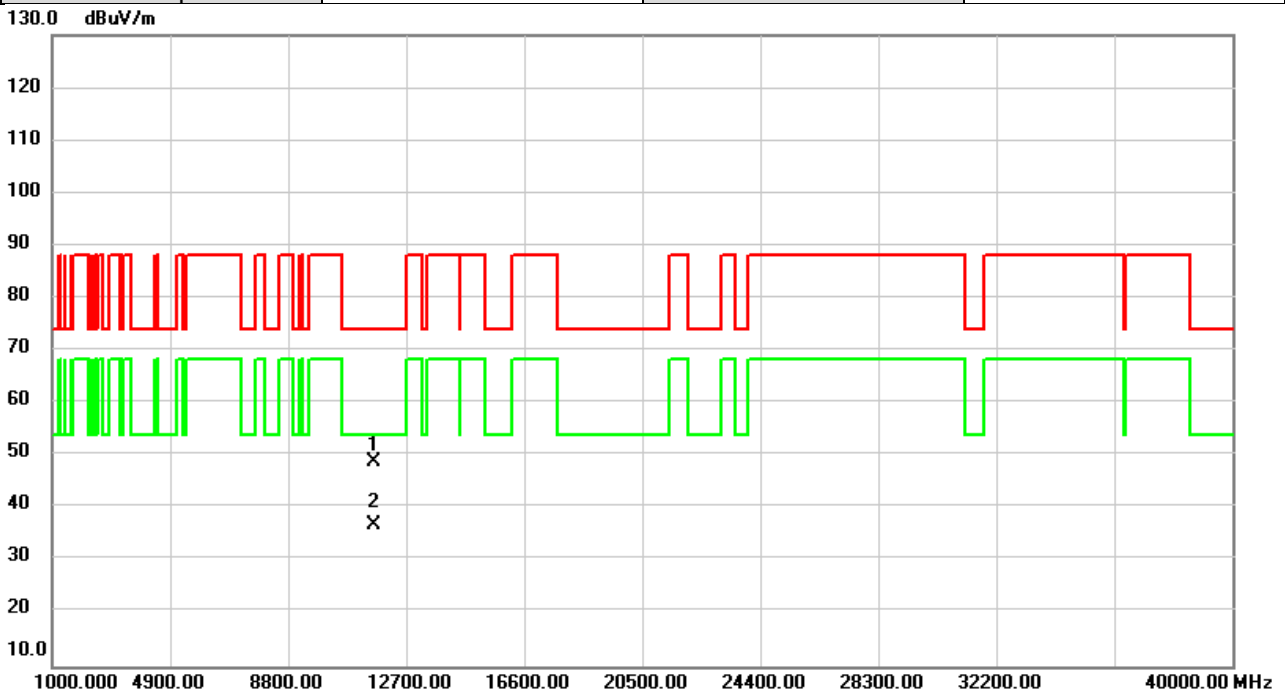

No.	Mk.	Freq.	Reading Level	Correct Factor	Measurement	Limit	Over	Detector	Comment
		MHz	dBuV	dB	dBuV/m	dBuV/m	dB		
1		11630.00	42.56	6.36	48.92	74.00	-25.08	peak	
2	*	11630.00	30.35	6.36	36.71	54.00	-17.29	AVG	

**REMARKS:**

- (1) Measurement Value = Reading Level + Correct Factor.
- (2) Margin Level = Measurement Value - Limit Value.

Test Mode	IEEE 802.11ax (HE160)	Test Date	2023/2/1
Test Frequency	5815MHz	Polarization	Horizontal
Temp	23°C	Hum.	59%

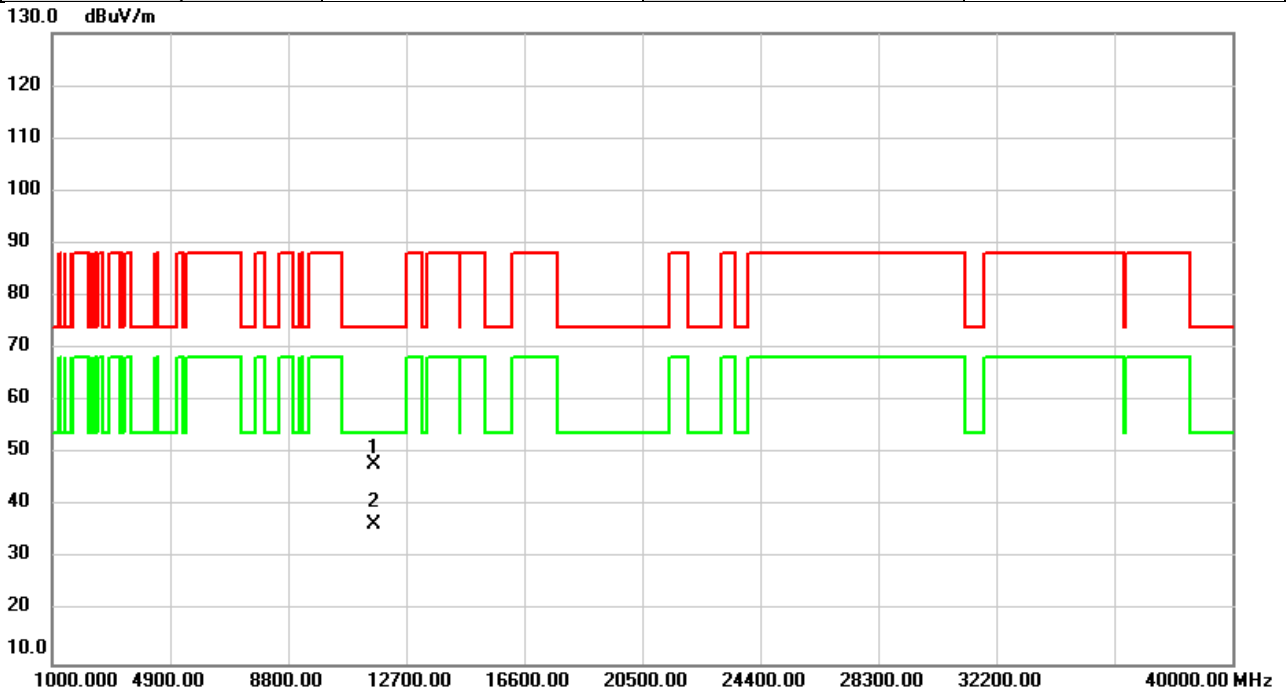

No.	Mk.	Freq. MHz	Reading Level dBuV	Correct Factor dB	Measure- ment dBuV/m	Limit dBuV/m	Over dB	Detector	Comment
1		11630.00	41.67	6.36	48.03	74.00	-25.97	peak	
2	*	11630.00	30.20	6.36	36.56	54.00	-17.44	AVG	

**REMARKS:**

- (1) Measurement Value = Reading Level + Correct Factor.
- (2) Margin Level = Measurement Value - Limit Value.

## APPENDIX D    MAXIMUM E.I.R.P.



Test Mode	IEEE 802.11a_Ant. 1	Tested Date	2023/1/16
-----------	---------------------	-------------	-----------

Test Frequency (MHz)	Conducted Power (dBm)	Conducted Power (W)	E.I.R.P. (dBm)	E.I.R.P. (W)	E.I.R.P. Limit (dBm)	E.I.R.P. Limit (W)	Result
5845	12.51	0.0178	16.23	0.0420	30.00	1.0000	Pass
5865	12.48	0.0177	16.20	0.0417	30.00	1.0000	Pass
5885	12.41	0.0174	16.13	0.0410	30.00	1.0000	Pass

Test Mode	IEEE 802.11a_Ant. 2	Tested Date	2023/1/16
-----------	---------------------	-------------	-----------

Test Frequency (MHz)	Conducted Power (dBm)	Conducted Power (W)	E.I.R.P. (dBm)	E.I.R.P. (W)	E.I.R.P. Limit (dBm)	E.I.R.P. Limit (W)	Result
5845	13.02	0.0200	16.74	0.0472	30.00	1.0000	Pass
5865	12.94	0.0197	16.66	0.0463	30.00	1.0000	Pass
5885	12.52	0.0179	16.24	0.0421	30.00	1.0000	Pass

Test Mode	IEEE 802.11a_Total	Tested Date	2023/1/16
-----------	--------------------	-------------	-----------

Test Frequency (MHz)	Conducted Power (dBm)	Conducted Power (W)	E.I.R.P. (dBm)	E.I.R.P. (W)	E.I.R.P. Limit (dBm)	E.I.R.P. Limit (W)	Result
5845	15.78	0.0379	19.50	0.0892	30.00	1.0000	Pass
5865	15.73	0.0374	19.45	0.0880	30.00	1.0000	Pass
5885	15.48	0.0353	19.20	0.0831	30.00	1.0000	Pass

Test Mode	IEEE 802.11ac (VHT20)_Ant. 1	Tested Date	2023/1/16
-----------	------------------------------	-------------	-----------

Test Frequency (MHz)	Conducted Power (dBm)	Conducted Power (W)	E.I.R.P. (dBm)	E.I.R.P. (W)	E.I.R.P. Limit (dBm)	E.I.R.P. Limit (W)	Result
5845	12.71	0.0187	16.43	0.0440	30.00	1.0000	Pass
5865	12.56	0.0180	16.28	0.0425	30.00	1.0000	Pass
5885	12.50	0.0178	16.22	0.0419	30.00	1.0000	Pass

Test Mode	IEEE 802.11ac (VHT20)_Ant. 2	Tested Date	2023/1/16
-----------	------------------------------	-------------	-----------

Test Frequency (MHz)	Conducted Power (dBm)	Conducted Power (W)	E.I.R.P. (dBm)	E.I.R.P. (W)	E.I.R.P. Limit (dBm)	E.I.R.P. Limit (W)	Result
5845	13.14	0.0206	16.86	0.0485	30.00	1.0000	Pass
5865	12.95	0.0197	16.67	0.0465	30.00	1.0000	Pass
5885	12.64	0.0184	16.36	0.0433	30.00	1.0000	Pass

Test Mode	IEEE 802.11ac (VHT20)_Total	Tested Date	2023/1/16
-----------	-----------------------------	-------------	-----------

Test Frequency (MHz)	Conducted Power (dBm)	Conducted Power (W)	E.I.R.P. (dBm)	E.I.R.P. (W)	E.I.R.P. Limit (dBm)	E.I.R.P. Limit (W)	Result
5845	15.94	0.0393	19.66	0.0925	30.00	1.0000	Pass
5865	15.77	0.0378	19.49	0.0889	30.00	1.0000	Pass
5885	15.58	0.0361	19.30	0.0851	30.00	1.0000	Pass

Test Mode	IEEE 802.11ac (VHT40)_Ant. 1	Tested Date	2023/1/16
-----------	------------------------------	-------------	-----------

Test Frequency (MHz)	Conducted Power (dBm)	Conducted Power (W)	E.I.R.P. (dBm)	E.I.R.P. (W)	E.I.R.P. Limit (dBm)	E.I.R.P. Limit (W)	Result
5835	14.80	0.0302	18.52	0.0711	30.00	1.0000	Pass
5875	15.11	0.0324	18.83	0.0764	30.00	1.0000	Pass

Test Mode	IEEE 802.11ac (VHT40)_Ant. 2	Tested Date	2023/1/16
-----------	------------------------------	-------------	-----------

Test Frequency (MHz)	Conducted Power (dBm)	Conducted Power (W)	E.I.R.P. (dBm)	E.I.R.P. (W)	E.I.R.P. Limit (dBm)	E.I.R.P. Limit (W)	Result
5835	14.98	0.0315	18.70	0.0741	30.00	1.0000	Pass
5875	15.20	0.0331	18.92	0.0780	30.00	1.0000	Pass

Test Mode	IEEE 802.11ac (VHT40)_Total	Tested Date	2023/1/16
-----------	-----------------------------	-------------	-----------

Test Frequency (MHz)	Conducted Power (dBm)	Conducted Power (W)	E.I.R.P. (dBm)	E.I.R.P. (W)	E.I.R.P. Limit (dBm)	E.I.R.P. Limit (W)	Result
5835	17.90	0.0617	21.62	0.1453	30.00	1.0000	Pass
5875	18.17	0.0655	21.89	0.1544	30.00	1.0000	Pass

Test Mode	IEEE 802.11ac (VHT80)_Ant. 1	Tested Date	2023/1/16
-----------	------------------------------	-------------	-----------

Test Frequency (MHz)	Conducted Power (dBm)	Conducted Power (W)	E.I.R.P. (dBm)	E.I.R.P. (W)	E.I.R.P. Limit (dBm)	E.I.R.P. Limit (W)	Result
5855	14.12	0.0258	17.84	0.0608	30.00	1.0000	Pass

Test Mode	IEEE 802.11ac (VHT80)_Ant. 2	Tested Date	2023/1/16
-----------	------------------------------	-------------	-----------

Test Frequency (MHz)	Conducted Power (dBm)	Conducted Power (W)	E.I.R.P. (dBm)	E.I.R.P. (W)	E.I.R.P. Limit (dBm)	E.I.R.P. Limit (W)	Result
5855	14.61	0.0289	18.33	0.0681	30.00	1.0000	Pass

Test Mode	IEEE 802.11ac (VHT80)_Total	Tested Date	2023/1/16
-----------	-----------------------------	-------------	-----------

Test Frequency (MHz)	Conducted Power (dBm)	Conducted Power (W)	E.I.R.P. (dBm)	E.I.R.P. (W)	E.I.R.P. Limit (dBm)	E.I.R.P. Limit (W)	Result
5855	17.38	0.0547	21.10	0.1289	30.00	1.0000	Pass

Test Mode	IEEE 802.11ac (VHT160)_Ant. 1	Tested Date	2023/1/16
-----------	-------------------------------	-------------	-----------

Test Frequency (MHz)	Conducted Power (dBm)	Conducted Power (W)	E.I.R.P. (dBm)	E.I.R.P. (W)	E.I.R.P. Limit (dBm)	E.I.R.P. Limit (W)	Result
5815	13.12	0.0205	16.84	0.0483	30.00	1.0000	Pass

Test Mode	IEEE 802.11ac (VHT160)_Ant. 2	Tested Date	2023/1/16
-----------	-------------------------------	-------------	-----------

Test Frequency (MHz)	Conducted Power (dBm)	Conducted Power (W)	E.I.R.P. (dBm)	E.I.R.P. (W)	E.I.R.P. Limit (dBm)	E.I.R.P. Limit (W)	Result
5815	13.54	0.0226	17.26	0.0532	30.00	1.0000	Pass

Test Mode	IEEE 802.11ac (VHT160)_Total	Tested Date	2023/1/16
-----------	------------------------------	-------------	-----------

Test Frequency (MHz)	Conducted Power (dBm)	Conducted Power (W)	E.I.R.P. (dBm)	E.I.R.P. (W)	E.I.R.P. Limit (dBm)	E.I.R.P. Limit (W)	Result
5815	16.35	0.0431	20.07	0.1015	30.00	1.0000	Pass

Test Mode	IEEE 802.11ax (HE20)_Ant. 1	Tested Date	2023/1/16
-----------	-----------------------------	-------------	-----------

Test Frequency (MHz)	Conducted Power (dBm)	Conducted Power (W)	E.I.R.P. (dBm)	E.I.R.P. (W)	E.I.R.P. Limit (dBm)	E.I.R.P. Limit (W)	Result
5845	12.99	0.0199	16.71	0.0469	30.00	1.0000	Pass
5865	12.84	0.0192	16.56	0.0453	30.00	1.0000	Pass
5885	12.61	0.0182	16.33	0.0430	30.00	1.0000	Pass

Test Mode	IEEE 802.11ax (HE20)_Ant. 2	Tested Date	2023/1/16
-----------	-----------------------------	-------------	-----------

Test Frequency (MHz)	Conducted Power (dBm)	Conducted Power (W)	E.I.R.P. (dBm)	E.I.R.P. (W)	E.I.R.P. Limit (dBm)	E.I.R.P. Limit (W)	Result
5845	13.41	0.0219	17.13	0.0516	30.00	1.0000	Pass
5865	13.45	0.0221	17.17	0.0521	30.00	1.0000	Pass
5885	13.18	0.0208	16.90	0.0490	30.00	1.0000	Pass

Test Mode	IEEE 802.11ax (HE20)_Total	Tested Date	2023/1/16
-----------	----------------------------	-------------	-----------

Test Frequency (MHz)	Conducted Power (dBm)	Conducted Power (W)	E.I.R.P. (dBm)	E.I.R.P. (W)	E.I.R.P. Limit (dBm)	E.I.R.P. Limit (W)	Result
5845	16.22	0.0418	19.94	0.0985	30.00	1.0000	Pass
5865	16.17	0.0414	19.89	0.0974	30.00	1.0000	Pass
5885	15.91	0.0390	19.63	0.0919	30.00	1.0000	Pass

Test Mode	IEEE 802.11ax (HE40)_Ant. 1	Tested Date	2023/1/16
-----------	-----------------------------	-------------	-----------

Test Frequency (MHz)	Conducted Power (dBm)	Conducted Power (W)	E.I.R.P. (dBm)	E.I.R.P. (W)	E.I.R.P. Limit (dBm)	E.I.R.P. Limit (W)	Result
5835	15.09	0.0323	18.81	0.0760	30.00	1.0000	Pass
5875	15.29	0.0338	19.01	0.0796	30.00	1.0000	Pass

Test Mode	IEEE 802.11ax (HE40)_Ant. 2	Tested Date	2023/1/16
-----------	-----------------------------	-------------	-----------

Test Frequency (MHz)	Conducted Power (dBm)	Conducted Power (W)	E.I.R.P. (dBm)	E.I.R.P. (W)	E.I.R.P. Limit (dBm)	E.I.R.P. Limit (W)	Result
5835	15.04	0.0319	18.76	0.0752	30.00	1.0000	Pass
5875	14.77	0.0300	18.49	0.0706	30.00	1.0000	Pass

Test Mode	IEEE 802.11ax (HE40)_Total	Tested Date	2023/1/16
-----------	----------------------------	-------------	-----------

Test Frequency (MHz)	Conducted Power (dBm)	Conducted Power (W)	E.I.R.P. (dBm)	E.I.R.P. (W)	E.I.R.P. Limit (dBm)	E.I.R.P. Limit (W)	Result
5835	18.08	0.0642	21.80	0.1512	30.00	1.0000	Pass
5875	18.05	0.0638	21.77	0.1502	30.00	1.0000	Pass

Test Mode	IEEE 802.11ax (HE80)_Ant. 1		Tested Date	2023/1/16
-----------	-----------------------------	--	-------------	-----------

Test Frequency (MHz)	Conducted Power (dBm)	Conducted Power (W)	E.I.R.P. (dBm)	E.I.R.P. (W)	E.I.R.P. Limit (dBm)	E.I.R.P. Limit (W)	Result
5855	14.32	0.0270	18.04	0.0637	30.00	1.0000	Pass

Test Mode	IEEE 802.11ax (HE80)_Ant. 2		Tested Date	2023/1/16
-----------	-----------------------------	--	-------------	-----------

Test Frequency (MHz)	Conducted Power (dBm)	Conducted Power (W)	E.I.R.P. (dBm)	E.I.R.P. (W)	E.I.R.P. Limit (dBm)	E.I.R.P. Limit (W)	Result
5855	14.63	0.0290	18.35	0.0684	30.00	1.0000	Pass

Test Mode	IEEE 802.11ax (HE80)_Total		Tested Date	2023/1/16
-----------	----------------------------	--	-------------	-----------

Test Frequency (MHz)	Conducted Power (dBm)	Conducted Power (W)	E.I.R.P. (dBm)	E.I.R.P. (W)	E.I.R.P. Limit (dBm)	E.I.R.P. Limit (W)	Result
5855	17.49	0.0561	21.21	0.1321	30.00	1.0000	Pass

Test Mode	IEEE 802.11ax (HE160)_Ant. 1		Tested Date	2023/1/16
-----------	------------------------------	--	-------------	-----------

Test Frequency (MHz)	Conducted Power (dBm)	Conducted Power (W)	E.I.R.P. (dBm)	E.I.R.P. (W)	E.I.R.P. Limit (dBm)	E.I.R.P. Limit (W)	Result
5815	13.09	0.0204	16.81	0.0480	30.00	1.0000	Pass

Test Mode	IEEE 802.11ax (HE160)_Ant. 2		Tested Date	2023/1/16
-----------	------------------------------	--	-------------	-----------

Test Frequency (MHz)	Conducted Power (dBm)	Conducted Power (W)	E.I.R.P. (dBm)	E.I.R.P. (W)	E.I.R.P. Limit (dBm)	E.I.R.P. Limit (W)	Result
5815	13.61	0.0230	17.33	0.0541	30.00	1.0000	Pass

Test Mode	IEEE 802.11ax (HE160)_Total		Tested Date	2023/1/16
-----------	-----------------------------	--	-------------	-----------

Test Frequency (MHz)	Conducted Power (dBm)	Conducted Power (W)	E.I.R.P. (dBm)	E.I.R.P. (W)	E.I.R.P. Limit (dBm)	E.I.R.P. Limit (W)	Result
5815	16.37	0.0433	20.09	0.1020	30.00	1.0000	Pass

**End of Test Report**