

System Check_B2450_0427

DUT: Dipole 2450 MHz D2450V2;

Communication System: UID 0, CW (0); Frequency: 2450 MHz; Duty Cycle: 1:1
Medium parameters used (interpolated): $f = 2450$ MHz; $\sigma = 2.005$ S/m; $\epsilon_r = 51.47$; $\rho = 1000$ kg/m³
Ambient Temperature : 23.3 °C; Liquid Temperature : 22.4 °C

DASY Configuration:

- Probe: EX3DV4 - SN7396; ConvF(7.7, 7.7, 7.7) @ 2450 MHz; Calibrated: 2018-05-29
- Sensor-Surface: 4mm (Mechanical Surface Detection), $z = 1.0, 31.0$
- Electronics: DAE3 Sn536; Calibrated: 2018-10-15
- Phantom: ELI v5.0; Type: QDOVA002AA; Serial: TP:1222
- DASY52 52.10.2(1495); SEMCAD X 14.6.12(7450)

Area Scan (7x7x1): Interpolated grid: $dx=12$ mm, $dy=12$ mm
Maximum value of SAR (interpolated) = 15.6 W/kg

Zoom Scan (7x7x7)/Cube 0: Measurement grid: $dx=5$ mm, $dy=5$ mm, $dz=5$ mm
Reference Value = 99.55 V/m; Power Drift = 0.01 dB
Peak SAR (extrapolated) = 24.8 W/kg
SAR(1 g) = 12.5 W/kg; SAR(10 g) = 5.78 W/kg
Maximum value of SAR (measured) = 14.3 W/kg

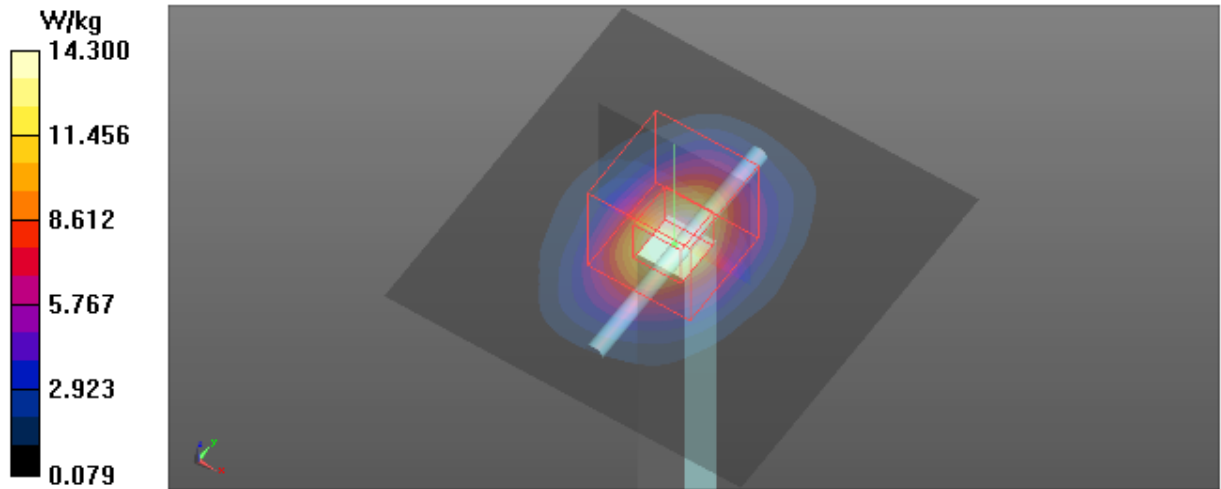

System Check_B5300_0427

DUT: Dipole D5GHzV2;

Communication System: UID 0, CW (0); Frequency: 5300 MHz; Duty Cycle: 1:1
Medium parameters used: $f = 5300$ MHz; $\sigma = 5.462$ S/m; $\epsilon_r = 47.107$; $\rho = 1000$ kg/m³
Ambient Temperature : 23.5 °C; Liquid Temperature : 22.5 °C

DASY Configuration:

- Probe: EX3DV4 - SN7396; ConvF(5.05, 5.05, 5.05) @ 5300 MHz; Calibrated: 2018-05-29
- Sensor-Surface: 2mm (Mechanical Surface Detection), $z = 1.0, 23.0$
- Electronics: DAE3 Sn536; Calibrated: 2018-10-15
- Phantom: ELI v5.0; Type: QDOVA002AA; Serial: TP:1222
- DASY52 52.10.2(1495); SEMCAD X 14.6.12(7450)

Area Scan (5x5x1): Interpolated grid: $dx=10$ mm, $dy=10$ mm
Maximum value of SAR (interpolated) = 14.3 W/kg

Zoom Scan (7x7x12)/Cube 0: Measurement grid: $dx=4$ mm, $dy=4$ mm, $dz=2$ mm
Reference Value = 36.45 V/m; Power Drift = -0.05 dB
Peak SAR (extrapolated) = 30.7 W/kg
SAR(1 g) = 6.87 W/kg; SAR(10 g) = 1.94 W/kg
Maximum value of SAR (measured) = 14.7 W/kg

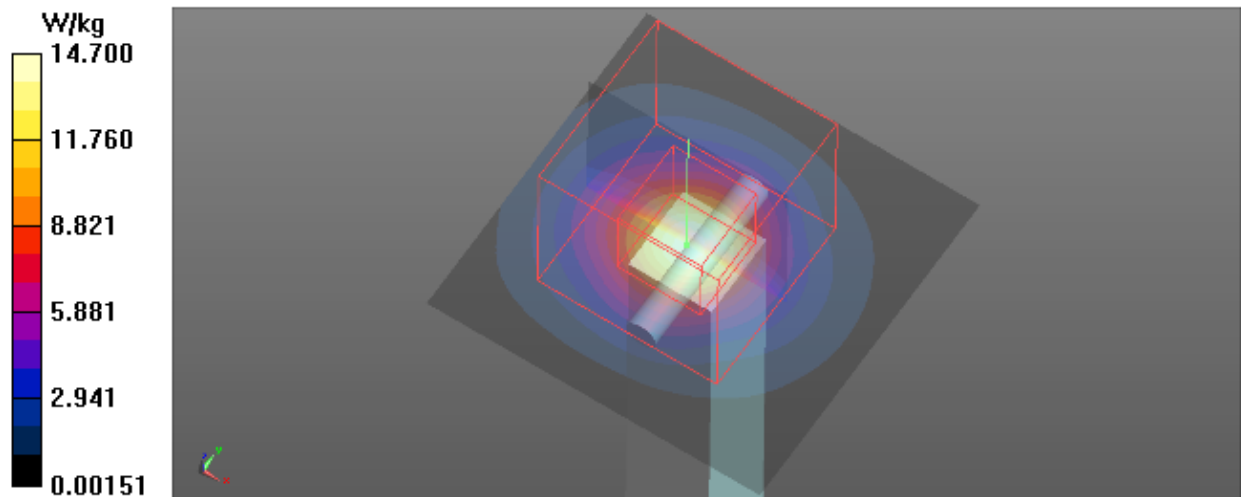

System Check_B5500_0427

DUT: Dipole D5GHzV2;

Communication System: UID 0, CW (0); Frequency: 5500 MHz; Duty Cycle: 1:1
Medium parameters used: $f = 5500$ MHz; $\sigma = 5.749$ S/m; $\epsilon_r = 46.751$; $\rho = 1000$ kg/m³
Ambient Temperature : 23.5 °C; Liquid Temperature : 22.5 °C

DASY Configuration:

- Probe: EX3DV4 - SN7396; ConvF(4.38, 4.38, 4.38) @ 5500 MHz; Calibrated: 2018-05-29
- Sensor-Surface: 2mm (Mechanical Surface Detection), $z = 1.0, 23.0$
- Electronics: DAE3 Sn536; Calibrated: 2018-10-15
- Phantom: ELI v5.0; Type: QDOVA002AA; Serial: TP:1222
- DASY52 52.10.2(1495); SEMCAD X 14.6.12(7450)

Area Scan (5x5x1): Interpolated grid: $dx=10$ mm, $dy=10$ mm
Maximum value of SAR (interpolated) = 15.3 W/kg

Zoom Scan (7x7x12)/Cube 0: Measurement grid: $dx=4$ mm, $dy=4$ mm, $dz=2$ mm
Reference Value = 36.06 V/m; Power Drift = 0.01 dB
Peak SAR (extrapolated) = 33.1 W/kg
SAR(1 g) = 7.28 W/kg; SAR(10 g) = 2.06 W/kg
Maximum value of SAR (measured) = 15.6 W/kg

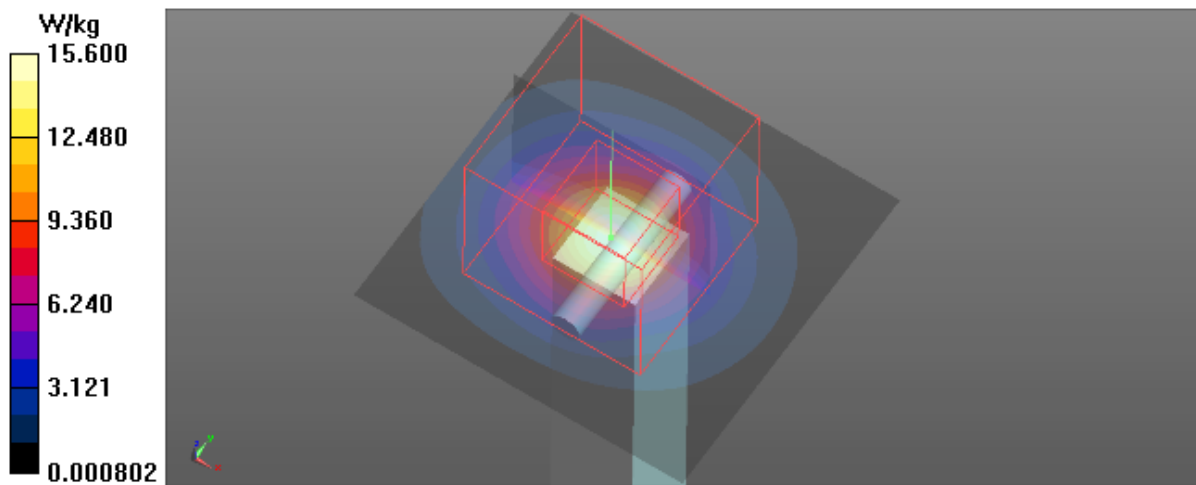

System Check_B5600_0427

DUT: Dipole D5GHzV2;

Communication System: UID 0, CW (0); Frequency: 5600 MHz; Duty Cycle: 1:1
Medium parameters used: $f = 5600$ MHz; $\sigma = 5.898$ S/m; $\epsilon_r = 46.563$; $\rho = 1000$ kg/m³
Ambient Temperature : 23.5 °C; Liquid Temperature : 22.5 °C

DASY Configuration:

- Probe: EX3DV4 - SN7396; ConvF(4.38, 4.38, 4.38) @ 5600 MHz; Calibrated: 2018-05-29
- Sensor-Surface: 2mm (Mechanical Surface Detection), $z = 1.0, 23.0$
- Electronics: DAE3 Sn536; Calibrated: 2018-10-15
- Phantom: ELI v5.0; Type: QDOVA002AA; Serial: TP:1222
- DASY52 52.10.2(1495); SEMCAD X 14.6.12(7450)

Area Scan (5x5x1): Interpolated grid: $dx=10$ mm, $dy=10$ mm
Maximum value of SAR (interpolated) = 16.9 W/kg

Zoom Scan (7x7x12)/Cube 0: Measurement grid: $dx=4$ mm, $dy=4$ mm, $dz=2$ mm
Reference Value = 37.14 V/m; Power Drift = -0.06 dB
Peak SAR (extrapolated) = 37.7 W/kg
SAR(1 g) = 8.06 W/kg; SAR(10 g) = 2.26 W/kg
Maximum value of SAR (measured) = 17.4 W/kg

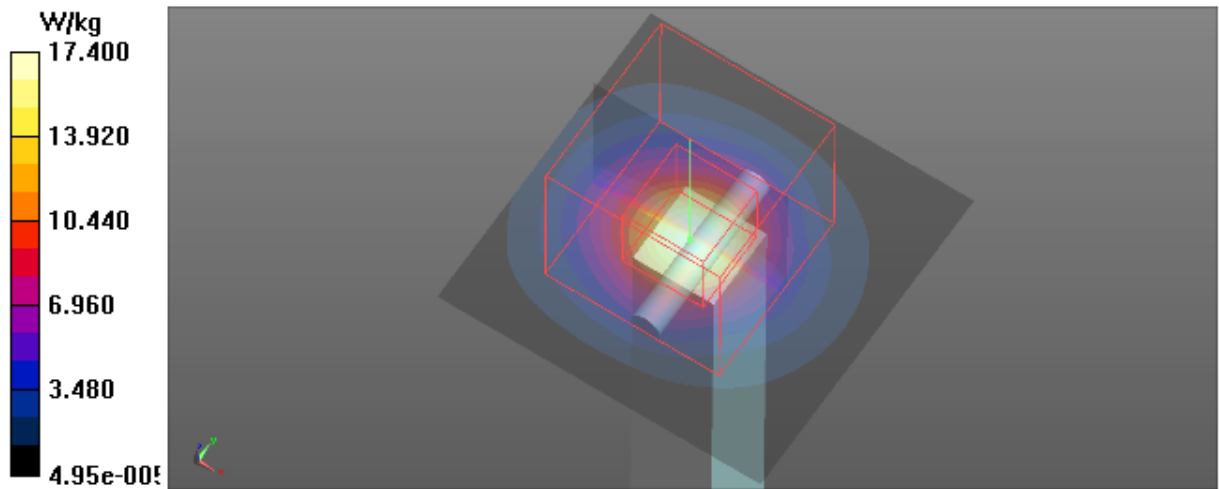

System Check_B5800_0427

DUT: Dipole D5GHzV2;

Communication System: UID 0, CW (0); Frequency: 5800 MHz; Duty Cycle: 1:1
Medium parameters used: $f = 5800$ MHz; $\sigma = 6.185$ S/m; $\epsilon_r = 46.167$; $\rho = 1000$ kg/m³
Ambient Temperature : 23.5 °C; Liquid Temperature : 22.5 °C

DASY Configuration:

- Probe: EX3DV4 - SN7396; ConvF(4.5, 4.5, 4.5) @ 5800 MHz; Calibrated: 2018-05-29
- Sensor-Surface: 2mm (Mechanical Surface Detection), $z = 1.0, 23.0$
- Electronics: DAE3 Sn536; Calibrated: 2018-10-15
- Phantom: ELI v5.0; Type: QDOVA002AA; Serial: TP:1222
- DASY52 52.10.2(1495); SEMCAD X 14.6.12(7450)

Area Scan (6x6x1): Interpolated grid: $dx=10$ mm, $dy=10$ mm
Maximum value of SAR (interpolated) = 20.3 W/kg

Zoom Scan (7x7x12)/Cube 0: Measurement grid: $dx=4$ mm, $dy=4$ mm, $dz=2$ mm
Reference Value = 35.39 V/m; Power Drift = -0.03 dB
Peak SAR (extrapolated) = 35.3 W/kg
SAR(1 g) = 7.5 W/kg; SAR(10 g) = 2.13 W/kg
Maximum value of SAR (measured) = 16.1 W/kg

