



FCC PART 15C & RSS-247 TEST REPORT FOR CERTIFICATION

On Behalf of

Razer Inc.

Notebook

RZ09-0239

FCC ID: RWO-RZ090239

IC: 8092D-RZ090239

Prepared for : Razer Inc.

201 3rd Street, Suite 900, San Francisco CA 94103, USA

Prepared By : UL Verification Services (Guangzhou) Co., Ltd, Song Shan
Lake Branch

Room 101, Building 10, Innovation Technology Park,
Song Shan Lake Hi tech Development Zone, Dongguan,
523808, China

Tel: +86 769 33817100

Fax: +86 769 33244054

Website: www.ul.com

Report Number : 4788146393

Date of Test : Aug.29~Sep.19,2017

Date of Report : Sep.20,2017



TABLE OF CONTENTS

Description	Page
1. SUMMARY OF STANDARDS AND RESULTS.....	1-1
1.1. Description of Standards and Results	1-1
2. GENERAL INFORMATION	2-1
2.1. Description of Device (EUT).....	2-1
2.2. Tested Supporting System Details	2-3
2.3. Block Diagram of connection between EUT and simulators.....	2-3
2.4. Test information.....	2-3
2.5. Test Facility	2-4
2.6. Measurement Uncertainty:.....	2-4
3. MEASURING INSTRUMENT AND SOFTWARE USED.....	3-1
4. POWER LINE CONDUCTED EMISSION TEST	4-2
4.1. Block Diagram of Test Setup.....	4-2
4.2. Power Line Conducted Emission Test Limits.....	4-2
4.3. Configuration of EUT on Test	4-3
4.4. Operating Condition of EUT	4-3
4.5. Test Procedure	4-3
4.6. Power Line Conducted Emission Test Results	4-3
5. RADIATED EMISSION MEASUREMENT	5-1
5.1. Block Diagram of Test Setup.....	5-1
5.2. Radiated Emission Limit Standard:	5-2
5.3. EUT Configuration on Test	5-2
5.4. Operating Condition of EUT	5-2
5.5. Test Procedure	5-2
5.6. Radiated Emission Test Results.....	5-3
6. CONDUCTED SPURIOUS EMISSIONS.....	6-1
6.1. Limit.....	6-1
6.2. Test Procedure	6-1
6.3. Test result.....	6-1
7. 20 dB & 99% BANDWIDTH TEST	7-1
7.1. Limit.....	7-1
7.2. Test Procedure	7-1
7.3. Test Results.....	7-1
8. CARRIER FREQUENCY SEPARATION TEST	8-1
8.1. Limit.....	8-1
8.2. Test Procedure	8-1
8.3. Test Results.....	8-2
9. NUMBER OF HOPPING FREQUENCY TEST	9-1
9.1. Limit.....	9-1
9.2. Test Procedure	9-1
9.3. Test Results.....	9-1
10. DWELL TIME	10-1
10.1. Limit.....	10-1
10.2. Test Procedure	10-1



10.3.	Test Results	10-1
11.	MAXIMUM PEAK OUTPUT POWER TEST	11-1
11.1.	Limit for Peak output Power	11-1
11.2.	Test Procedure for Peak output Power	11-1
11.3.	Test Procedure for e.i.r.p.....	11-1
11.4.	Test Results	11-2
12.	BAND EDGE COMPLIANCE TEST	12-1
12.1.	Limit.....	12-1
12.2.	Test Procedure.....	12-1
12.3.	Test Results	12-1
13.	ANTENNA REQUIREMENT	13-1
13.1.	Standard Applicable.....	13-1
13.2.	Antenna Connected Construction	13-1
14.	DEVIATION TO TEST SPECIFICATIONS.....	14-1



TEST REPORT CERTIFICATION

Applicant : Razer Inc.
Manufacturer : Razer Inc.
Product : Notebook
FCC ID : RWO-RZ090239
IC : 8092D-RZ090239
(A) Model No. : RZ09-0239
(B) Serial No. : N/A
(C) Test Voltage : DC 20V From Adapter Input AC 120V/60Hz

Tested for comply with:
FCC CRF 47 Part 15 Subpart C
RSS-247, ISSUE 2, Feb 2017
RSS-Gen, ISSUE 4, November 2014

Test procedure used:
ANSI C63.10: 2013

This Report is made under FCC Part 2.1075. No modifications were required during testing to bring this product into compliance.

This report applies to above tested sample only. This report shall not be reproduced in part without written approval of UL Verification Services (Guangzhou) Co., Ltd, Song Shan Lake Branch.

Date of Test : Aug.29~Sep.19,2017 Report of date: Sep.20,2017

Prepared by : *Kebo Zhang* Reviewed by : *Shawn Wen*
Kebo Zhang / Engineer Shawn Wen / Laboratory Leader

Approved & Authorized Signer : *Stephen Guo*
Stephen Guo / Laboratory Manager

1. SUMMARY OF STANDARDS AND RESULTS

1.1. Description of Standards and Results

The EUT has been tested according to the applicable standards as referenced below.

EMISSION		
Description of Test Item	Standard	Results
Power Line Conducted Emission Test	FCC Part 15: 15.207 RSS-247, ISSUE 2 RSS-Gen, ISSUE 4 ANSI C63.10 2013	PASS
Radiated Emission Test	FCC Part 15 15.209 FCC Part 15 15.247(d) RSS-247, ISSUE 2 RSS-Gen, ISSUE 4 ANSI C63.10 2013	PASS
Conducted Spurious Emissions	FCC Part 15: 15.247(a)(1) RSS-247, ISSUE 2 RSS-Gen, ISSUE 4 ANSI C63.10 2013	PASS
Carrier Frequency Separation Test	FCC Part 15: 15.247(a)(1) RSS-247, ISSUE 2 RSS-Gen, ISSUE 4 ANSI C63.10 2013	PASS
20dB & 99% Bandwidth Test	FCC Part 15: 15.215 RSS-247, ISSUE 2 RSS-Gen, ISSUE 4 ANSI C63.10 2013	PASS
Number Of Hopping Frequency Test	FCC Part 15: 15.247(a)(1)(iii) RSS-247, ISSUE 2 RSS-Gen, ISSUE 4 ANSI C63.10 2013	PASS
Dwell Time Test	FCC Part 15: 15.247(a)(1)(iii) RSS-247, ISSUE 2 RSS-Gen, ISSUE 4 ANSI C63.10 2013	PASS
Maximum Peak Output Power Test	FCC Part 15 15.247(b)(1) RSS-247, ISSUE 2 RSS-Gen, ISSUE 4 ANSI C63.10 2013	PASS
Band Edge Compliance Test	FCC Part 15 15.247(d) RSS-247, ISSUE 2 RSS-Gen, ISSUE 4 ANSI C63.10 2013	PASS

2. GENERAL INFORMATION

2.1. Description of Device (EUT)

Product	: Notebook
Model No.	: RZ09-0239
FCC ID	: RWO-RZ090239
IC	: 8092D-RZ090239
Radio	: IEEE802.11 a/b/g/n/ac; Bluetooth V3.0+EDR; Bluetooth V4.1
Operation Frequency	: IEEE 802.11a: 5180MHz—5240MHz; 5260MHz—5320MHz 5500MHz—5700MHz; 5745MHz—5825MHz IEEE 802.11ac VHT20: 5180MHz—5240MHz; 5260MHz—5320MHz 5500MHz—5700MHz; 5745MHz—5825MHz IEEE 802.11ac VHT40: 5190MHz—5230MHz; 5270MHz—5310MHz 5510MHz—5670MHz; 5755MHz—5795MHz IEEE 802.11ac VHT80: 5210MHz, 5290MHz; 5530MHz—5610MHz; 5775MHz IEEE 802.11b: 2412MHz—2462MHz IEEE 802.11g: 2412MHz—2462MHz IEEE802.11nHT20: 2412MHz—2462MHz; 5180MHz—5240MHz; 5260MHz—5320MHz 5500MHz—5700MHz; 5745MHz—5825MHz IEEE802.11nHT40: 2422MHz—2452MHz; 5190MHz—5230MHz; 5270MHz—5310MHz 5510MHz—5670MHz; 5755MHz—5795MHz Bluetooth : 2402-2480MHz
Modulation Technology	: IEEE 802.11b: DSSS(CCK,DQPSK,DBPSK) IEEE 802.11a/g: OFDM(64QAM, 16QAM, QPSK, BPSK) IEEE 802.11ac VHT20, VHT40, VHT80: OFDM(16QAM, 64QAM, 256QAM, QPSK, BPSK) IEEE 802.11n HT20, HT40: OFDM (64QAM, 16QAM,QPSK,BPSK) Bluetooth V3.0+EDR: GFSK, $\pi/4$ DQPSK,8-DPSK Bluetooth V4.1:GFSK

Antenna : Antenna Type: PIFA
Assembly Gain Bluetooth: 1.89dBi
WIFI 2.4GHz:ANT 0: 1.89dBi; ANT 1: 3.08dBi
WIFI 5GHz:
Band 1: ANT 0: 2.91dBi; ANT 1: 2.96dBi
Band 2: ANT 0: 3.08dBi; ANT 1: 2.96dBi
Band 3: ANT 0: 1.61dBi; ANT 1: 2.99dBi
Band 4: ANT 0: 3.16dBi; ANT 1: 2.88dBi

Applicant : Razer Inc.
201 3rd Street, Suite 900, San Francisco, CA 94103

Manufacturer : Razer Inc.
201 3rd Street, Suite 900, San Francisco, CA 94103

Factory : BYD Precision Manufacture Co., Ltd
No.3001, Bao He Road, Baolong Industrial, Longgang Street, Longgang
Zone, Shenzhen, 518116, P.R., China

Power Adaptor : Manufacturer: Razer Inc. M/N: RC30-0239
Input: 100-240Vac; 50/60Hz, 2.0A
Output: 20V; 3.25A
DC Cable: Shielded, Undetachable, 2.0m

Power Cable : Unshielded, Detachable, 1.3m

Date of Test : Aug.29~Sep.19,2017

Date of Receipt : Aug.26,2017

Sample Type : Prototype production

2.2. Tested Supporting System Details

No.	Description	Manufacturer	Model	Serial No.
1.	Monitor	Lenovo	L2264W	N/A
		Power Cord: Unshielded, Detachable, 1.8m HDMI Cable: Shielded, Detachable, 2.0m		
2.	Headphone	OVANN	0V-T800V	N/A
		Data Cable: Shielded, Undetachable, 4.0m		
3.	USB Mouse	M0C5UO	Dell	512022645
		USB Cable: Shielded, Detachable, 1.0m		
4.	3.0 HDD	SONY	HD-E	3PDLOT15515005C
		USB Cable: Shielded, Detachable, 1.0m		

2.3. Block Diagram of connection between EUT and simulators

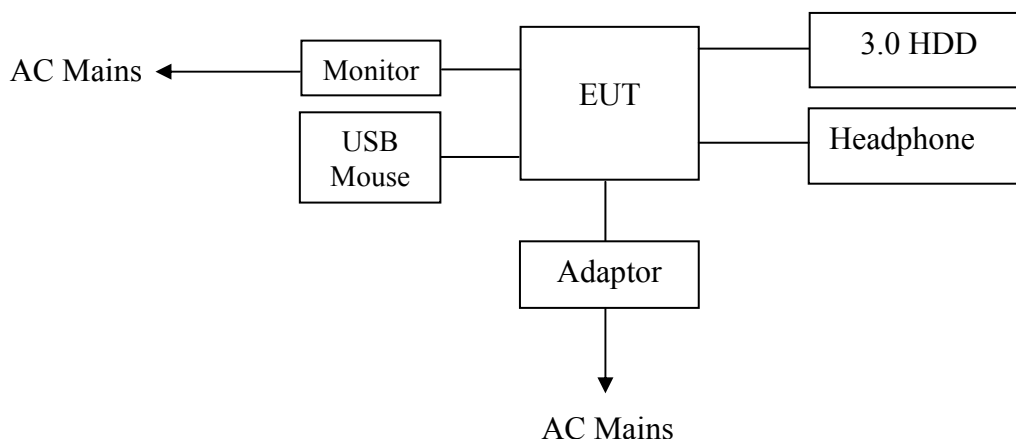

(EUT: Notebook)

2.4. Test information

A special software was used to control EUT work in Continuous TX mode(GFSK, $\pi/4$ DQPSK,8-DPSK Modulation), and select test channel.

Tested mode, channel, and data rate information			
Mode	data rate (Mbps)	Channel	Frequency (MHz)
Tx Mode GFSK modulation	1	Low :CH 0	2402
	1	Middle: CH39	2441
	1	High: CH78	2480
Tx Mode 8-DPSK modulation	3	Low :CH 0	2402
	3	Middle: CH39	2441
	3	High: CH78	2480

Note: $\pi/4$ DQPSK modulation is same type modulation with 8-DPSK, and according exploratory test, 8-DPSK will have worse emissions, so the final test were only performed with GFSK and 8-DPSK modulation.

2.5. Test Facility

Test Location	UL Verification Services (Guangzhou) Co., Ltd. Song Shan Lake Branch.
Address	Building 10, Innovation Technology Park, Song Shan Lake Hi tech Development Zone, Dongguan, 523808, China
Accreditation Certificate	<p>UL Verification Services (Guangzhou) Co., Ltd. Song Shan Lake Branch. EMC Laboratory has been accredited by A2LA for technical competence in the field of electrical testing, and proved to be in compliance with ISO/IEC 17025: 2005 General Requirements for the Competence of Testing and Calibration Laboratories and any additional program requirements in the identified field of testing. The Certificate Registration Number is 4102.01.</p> <p>UL Verification Services (Guangzhou) Co., Ltd. Song Shan Lake Branch. EMC Laboratory has been registered and fully described in a report filed with the FCC (Federal Communications Commission). The Designation Number is CN1187.</p> <p>UL Verification Services (Guangzhou) Co., Ltd. Song Shan Lake Branch. EMC Laboratory has been registered and fully described in a report filed with Industry Canada. The Company Number is 21320.</p>

2.6. Measurement Uncertainty:

Where relevant, the following measurement uncertainty levels have been estimated for tests performed on the apparatus

Test Item	Uncertainty
Uncertainty for Conduction emission test	2.90dB
Uncertainty for Radiation Emission test(include Fundamental emission) (30MHz-1GHz)	4.52dB
Uncertainty for Radiation Emission test (1GHz to 26GHz)(include Fundamental emission)	5.04dB(1-6GHz)
	5.30dB (6GHz-18Gz)
	5.23dB (18GHz-26Gz)
Note: This uncertainty represents an expanded uncertainty expressed at approximately the 95% confidence level using a coverage factor of k=2.	

3. MEASURING INSTRUMENT AND SOFTWARE USED

Conducted Emissions						
Instrument						
Used	Equipment	Manufacturer	Model No.	Serial No.	Last Cal.	Next Cal.
<input checked="" type="checkbox"/>	EMI Test Receiver	R&S	ESR3	101961	Dec.20, 2016	Dec.19, 2017
<input checked="" type="checkbox"/>	Two-Line V-Network	R&S	ENV216	101983	Dec.20, 2016	Dec.19, 2017
<input checked="" type="checkbox"/>	Artificial Mains Networks	Schwarzbeck	NSLK 8126	8126465	Feb.10, 2017	Feb.10, 2018
Radiated Emissions						
Instrument						
Used	Equipment	Manufacturer	Model No.	Serial No.	Last Cal.	Next Cal.
<input checked="" type="checkbox"/>	MXE EMI Receiver	KESIGHT	N9038A	MY56400 036	Feb. 24, 2017	Feb. 24, 2018
<input checked="" type="checkbox"/>	Hybrid Log Periodic Antenna	TDK	HLP-3003C	130960	Jan.09, 2016	Jan.09, 2019
<input checked="" type="checkbox"/>	Preamplifier	HP	8447D	2944A090 99	Feb. 13, 2017	Feb. 13, 2018
<input checked="" type="checkbox"/>	EMI Measurement Receiver	R&S	ESR26	101377	Dec. 20, 2016	Dec. 20, 2017
<input checked="" type="checkbox"/>	Horn Antenna	TDK	HRN-0118	130939	Jan. 09, 2016	Jan. 09, 2019
<input checked="" type="checkbox"/>	High Gain Horn Antenna	Schwarzbeck	BBHA-9170	691	Jan.06, 2016	Jan.06, 2019
<input checked="" type="checkbox"/>	Preamplifier	TDK	PA-02-0118	TRS-305- 00066	Jan. 14, 2017	Jan. 14, 2018
<input checked="" type="checkbox"/>	Preamplifier	TDK	PA-02-2	TRS-307- 00003	Dec. 20, 2016	Dec. 20, 2017
<input checked="" type="checkbox"/>	Loop antenna	Schwarzbeck	1519B	00008	Mar. 26, 2016	Mar. 26, 2019
Other instruments						
Used	Equipment	Manufacturer	Model No.	Serial No.	Last Cal.	Next Cal.
<input checked="" type="checkbox"/>	Spectrum Analyzer	Keysight	N9030A	MY55410 512	Dec. 20, 2016	Dec. 20, 2017
<input checked="" type="checkbox"/>	Power Meter	Keysight	N9031A	MY55416 024	Feb. 13, 2017	Feb. 13, 2018
<input checked="" type="checkbox"/>	Power Sensor	Keysight	N9323A	MY55440 013	Feb. 13, 2017	Feb. 13, 2018

4. POWER LINE CONDUCTED EMISSION TEST

4.1. Block Diagram of Test Setup

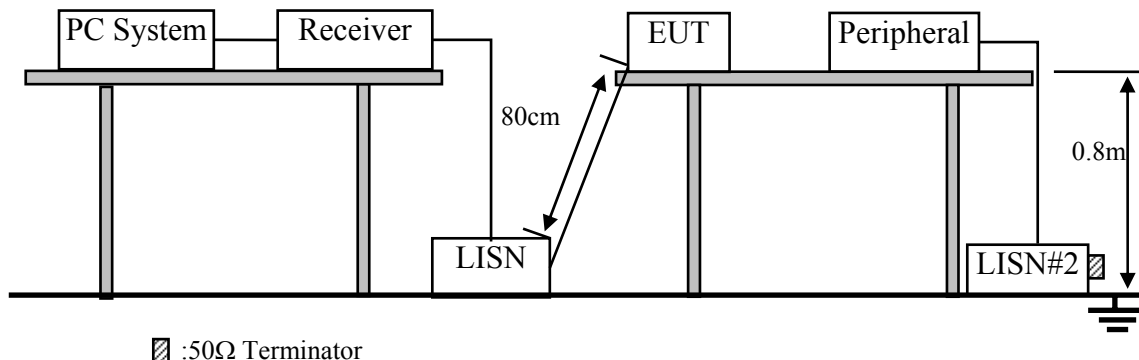

4.2. Power Line Conducted Emission Test Limits

Frequency	Maximum RF Line Voltage	
	Quasi-Peak Level dB(μV)	Average Level dB(μV)
150kHz ~ 500kHz	66 ~ 56*	56 ~ 46*
500kHz ~ 5MHz	56	46
5MHz ~ 30MHz	60	50

Notes: 1. * Decreasing linearly with logarithm of frequency.
 2. The lower limit shall apply at the transition frequencies.

4.3. Configuration of EUT on Test

The following equipment are installed on Power Line Conducted Emission Test to meet the commission requirement and operating regulations in a manner which tends to maximize its emission characteristics in a normal application.

4.3.1. Notebook (EUT)

Model No. : RZ09-0239
Serial No. : N/A

4.3.2. Support Equipment: As Tested Supporting System Details, in Section 2.2.

4.4. Operating Condition of EUT

4.4.1. Setup the EUT and simulator as shown as Section 3.2.

4.4.2. Turn on the power of all equipments.

4.4.3. PC run test software to control EUT work in BT 3.0 Tx mode.

4.5. Test Procedure

The EUT was placed on a non-metallic table, 80cm above the ground plane. The EUT Power Via PC connected to the power mains through a line impedance stabilization network (L.I.S.N.). This provides a 50 ohm coupling impedance for the EUT (Please refer the block diagram of the test setup and photographs). The AC line are checked to find out the maximum conducted emission. In order to find the maximum emission levels, the relative positions of equipment and all of the interface cables shall be changed according to ANSI C63.10: 2013 on Conducted Emission Test.

The bandwidth of test receiver (R & S ESCI) is set at 9kHz.

The frequency range from 150kHz to 30MHz is checked.

4.6. Power Line Conducted Emission Test Results

PASS. (All emissions not reported below are too low against the prescribed limits.)

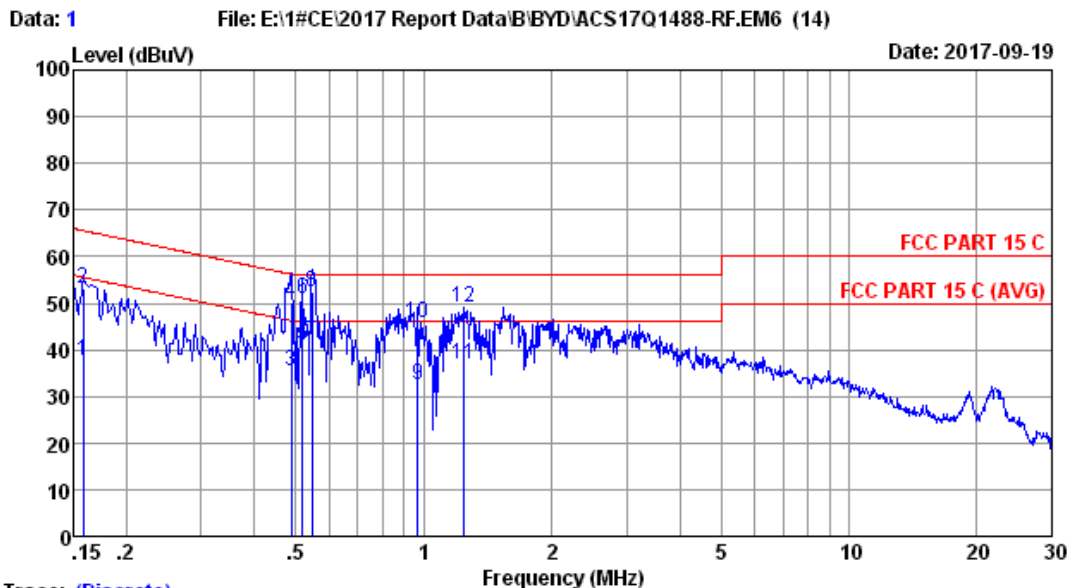

Trace: (Discrete)
 Site no :1# CE Data No :1
 Dis./Lisn :2017 LISN ENV216-L LISN phase:
 Limit :FCC PART 15 C
 Env./Ins. :23.3*C/45% Engineer :Lynn
 EUT :Notebook M/N:RZ09-0239
 Power Rating :DC 20V From Adaptor Input AC 120V/60Hz
 Test Mode :Tx Mode

No	Freq (MHz)	LISN Factor (dB)	Cable Loss (dB)	Reading (dBuV)	Emission Level (dBuV)	Limits (dBuV)	Margin (dB)	Remark
1	0.158	9.52	0.02	28.26	37.80	55.56	17.76	Average
2	0.158	9.52	0.02	43.52	53.06	65.56	12.50	QP
3	0.489	9.50	0.03	26.06	35.59	46.19	10.60	Average
4	0.489	9.50	0.03	40.82	50.35	56.19	5.84	QP
5	0.518	9.50	0.03	31.25	40.78	46.00	5.22	Average
6	0.518	9.50	0.03	41.49	51.02	56.00	4.98	QP
7	0.546	9.50	0.03	32.06	41.59	46.00	4.41	Average
8	0.546	9.50	0.03	42.75	52.28	56.00	3.72	QP
9	0.968	9.49	0.05	22.81	32.35	46.00	13.65	Average
10	0.968	9.49	0.05	36.38	45.92	56.00	10.08	QP
11	1.242	9.49	0.06	27.28	36.83	46.00	9.17	Average
12	1.242	9.49	0.06	39.70	49.25	56.00	6.75	QP

Remarks: 1.Emission Level=LISN Factor+Cable Loss+Reading.
 2.If the average limit is met when using a quasi-peak detector, the EUT shall be deemed to meet both limits and measurement with average detector is unnecessary.

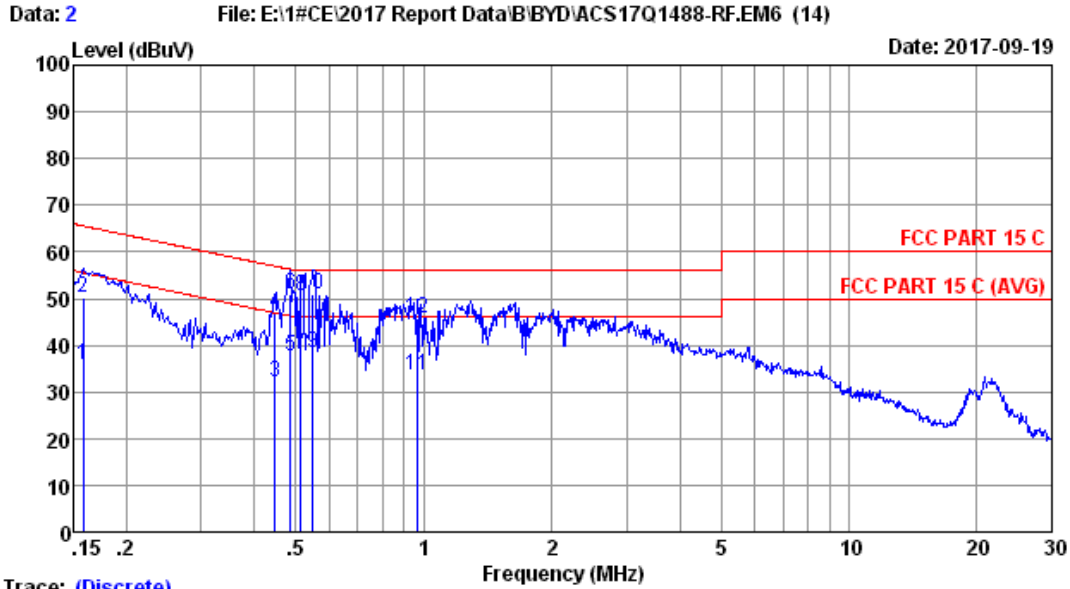

Trace: (Discrete)
 Site no :1# CE Data No :2
 Dis./Lisn :2017 LISN ENV216-N LISN phase:
 Limit :FCC PART 15 C
 Env./Ins. :23.3*C/45% Engineer :Lynn
 EUT :Notebook M/N:RZ09-0239
 Power Rating :DC 20V From Adaptor Input AC 120V/60Hz
 Test Mode :Tx Mode

No	Freq (MHz)	LISN Factor (dB)	Cable Loss (dB)	Reading (dBuV)	Emission Level (dBuV)	Limits (dBuV)	Margin (dB)	Remark
1	0.158	9.48	0.02	26.16	35.66	55.56	19.90	Average
2	0.158	9.48	0.02	40.74	50.24	65.56	15.32	QP
3	0.447	9.37	0.03	22.56	31.96	46.93	14.97	Average
4	0.447	9.37	0.03	37.59	46.99	56.93	9.94	QP
5	0.486	9.33	0.03	28.19	37.55	46.23	8.68	Average
6	0.486	9.33	0.03	41.42	50.78	56.23	5.45	QP
7	0.513	9.31	0.03	28.60	37.94	46.00	8.06	Average
8	0.513	9.31	0.03	41.06	50.40	56.00	5.60	QP
9	0.549	9.31	0.03	29.06	38.40	46.00	7.60	Average
10	0.549	9.31	0.03	41.52	50.86	56.00	5.14	QP
11	0.968	9.35	0.05	24.14	33.54	46.00	12.46	Average
12	0.968	9.35	0.05	36.44	45.84	56.00	10.16	QP

Remarks: 1.Emission Level=LISN Factor+Cable Loss+Reading.
 2.If the average limit is met when using a quasi-peak detector, the EUT shall be deemed to meet both limits and measurement with average detector is unnecessary.

5. RADIATED EMISSION MEASUREME

5.1. Block Diagram of Test Setup

For frequency range 30MHz-1000MHz

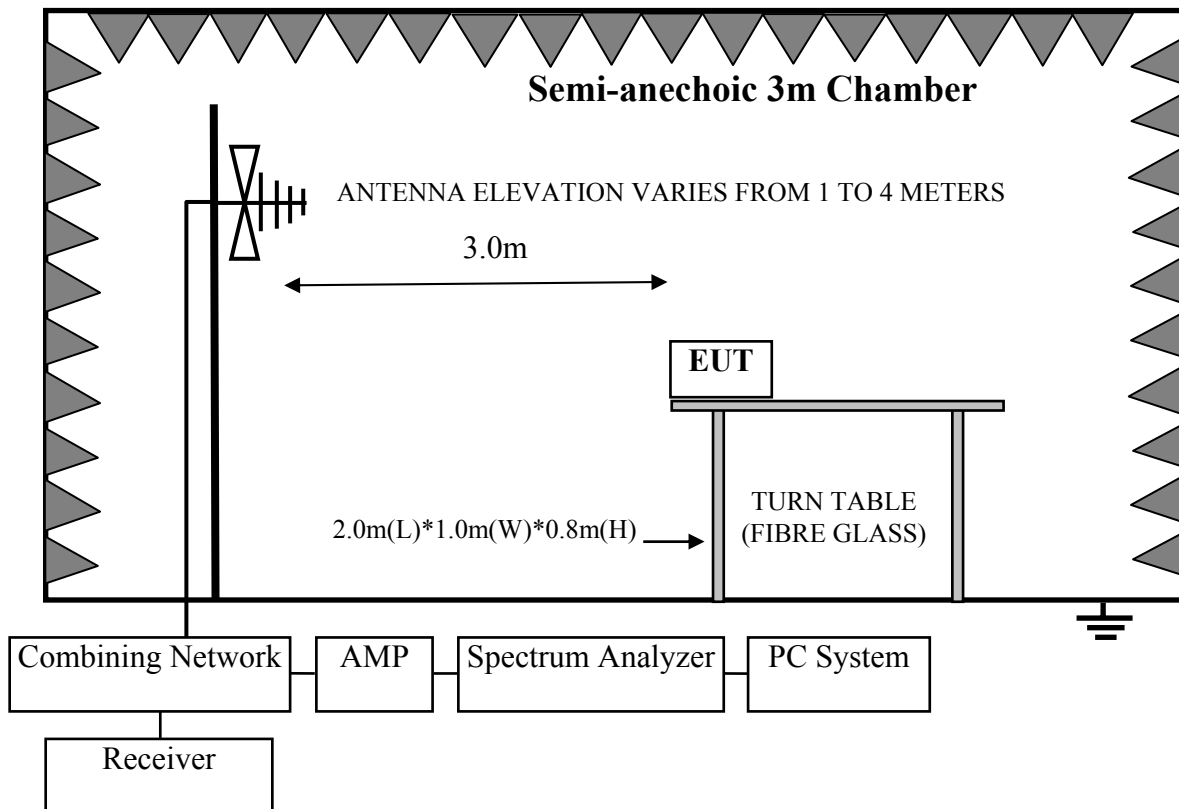

For frequency range 1GHz-25GHz

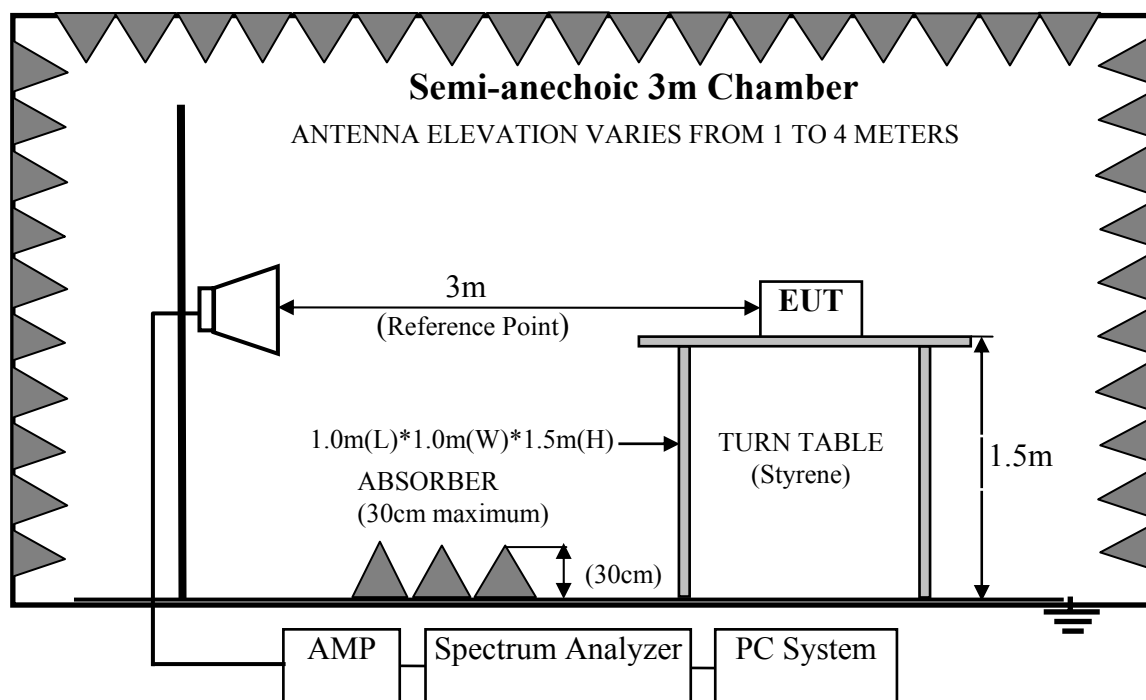

5.2.Radiated Emission Limit Standard:

FREQUENCY MHz	DISTANCE Meters	FIELD STRENGTHS LIMIT	
		μV/m	dB(μV)/m
30 ~ 88	3	100	40.0
88 ~ 216	3	150	43.5
216 ~ 960	3	200	46.0
960 ~ 1000	3	500	54.0
Above 1000MHz	3	74.0 dB(μV)/m (Peak) 54.0 dB(μV)/m (Average)	

- Remark :
- (1) Emission level dBμV = 20 log Emission level μV/m
 - (2) The smaller limit shall apply at the cross point between two frequency bands.
 - (3) Distance is the distance in meters between the measuring instrument, antenna and the closest point of any part of the device or system.
 - (4) The emission limits shown in the above table are based on measurements employing a CISPR quasi-peak detector except for the frequency bands 9-90 kHz, 110-490 kHz and above 1000MHz. Radiated emission limits in these three bands are based on measurements employing an average detector.

5.3.EUT Configuration on Test

The following equipment are installed on Radiated Emission Test to meet the commission requirements and operating regulations in a manner which tends to maximize its emission characteristics in normal application.

5.3.1. Notebook (EUT)

Model No. : RZ09-0239
 Serial No. : N/A

5.4.Operating Condition of EUT

- 5.4.1. Setup the EUT and simulator as shown as Section 4.2.
- 5.4.2. Turn on the power of all equipments.
- 5.4.3. Let EUT work in BT 3.0 Tx mode.

5.5.Test Procedure

Frequency below 30MHz:

The EUT setup on the turn table which has 0.8 m height to the ground. The turn table rotated 360 degrees and antenna fixed to 1 m to find the maximum emission level. In order to find the maximum emission, all of the interface cables were manipulated according to ANSI C63.10-2013 regulation.

EUT and its simulators are placed on a turn table, which is 0.8 meter high above ground for frequency 30MHz~1000MHz, 1.5 meter high above ground for frequency above 1GHz and put the absorbing with 2.4m(L)*2.4m(W)*0.3m(H) on the ground . The turn table can rotate 360 degrees to determine the position of the maximum emission level. Power on the EUT and let it working in test mode, then test it.EUT is set 3 meters away from the receiving antenna, which is mounted on a antenna tower. The antenna can be moved up and down between 1 meter and 4 meters to find out the maximum emission level. Broadband antenna (calibrated bilog antenna) is used as receiving antenna for frequency 30MHz~1000MHz, and the Horn antenna is used as receiving antenna for frequency above 1GHz. Both horizontal and vertical polarization of the antenna is set on Test. In order to find the maximum emission levels, all of the interface cables must be manipulated according to ANSI C63.10-2013 on radiated emission Test.

This test was performed with EUT in X, Y, Z position, and the worse case was found when EUT in X position as the test photo indicated.

The bandwidth of the EMI test receiver (R&S ESR7) is set at 120kHz for frequency range from 30MHz to 1000MHz.

The bandwidth of the Spectrum's RBW is set at 1MHz and VBW is set at 3MHz for peak emissions measurement above 1GHz

This device is pulse Modulated, a duty cycle factor was used to calculated average level based measured peak level.

The frequency range from 30MHz to 10th harmonic (25GHz) are checked. and no any emissions were found from 18GHz to 25 GHz, So the radiated emissions from 18GHz to 25GHz were not record.

5.6.Radiated Emission Test Results

PASS.

All the emissions from 30MHz to 25GHz were comply with the 15.209 Limit.

Note 1: The duty cycle factor for calculate average level is -24.583dB, and average limit is 20dB below peak limit, so if peak measured level comply with average limit, the average level was deemed to comply with average limit.

Note 2: The emissions (9kHz~30MHz) not reported for there is no emission be found.

Duty cycle factor = $20\log(Dwell\ time/100ms) = -24.583dB$

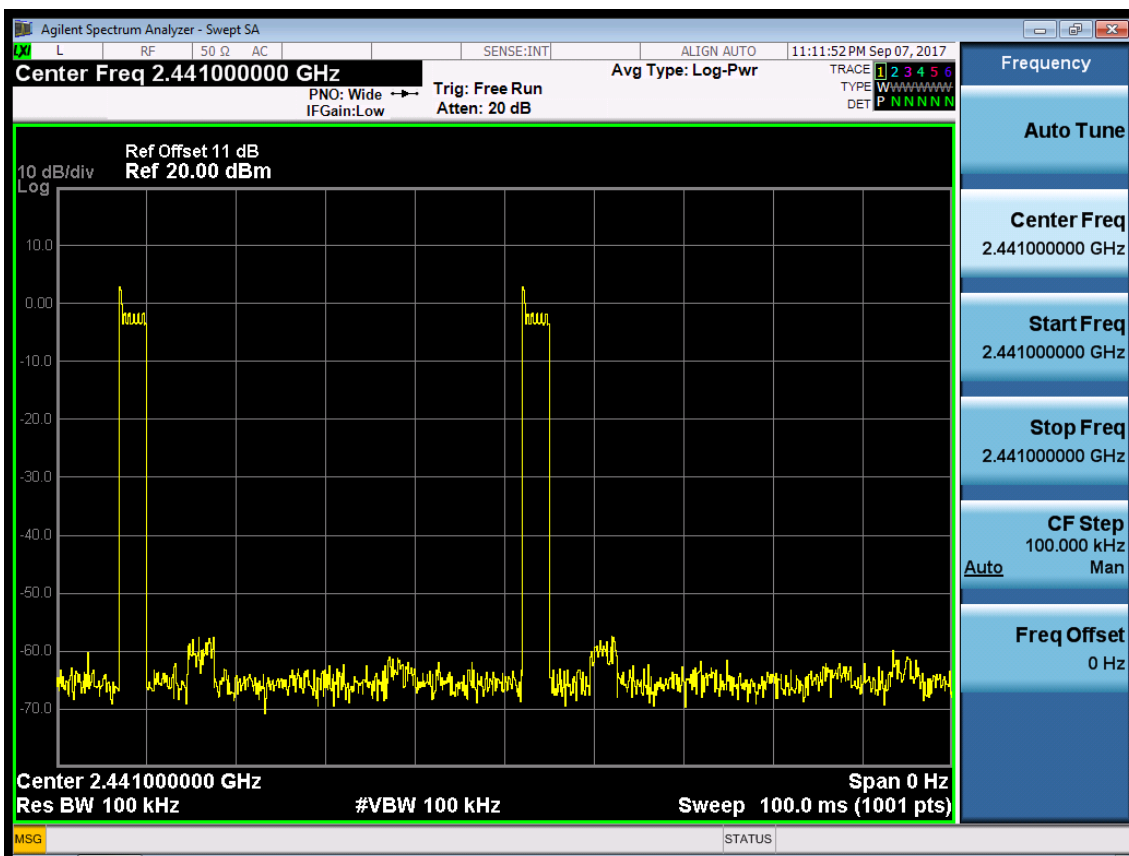
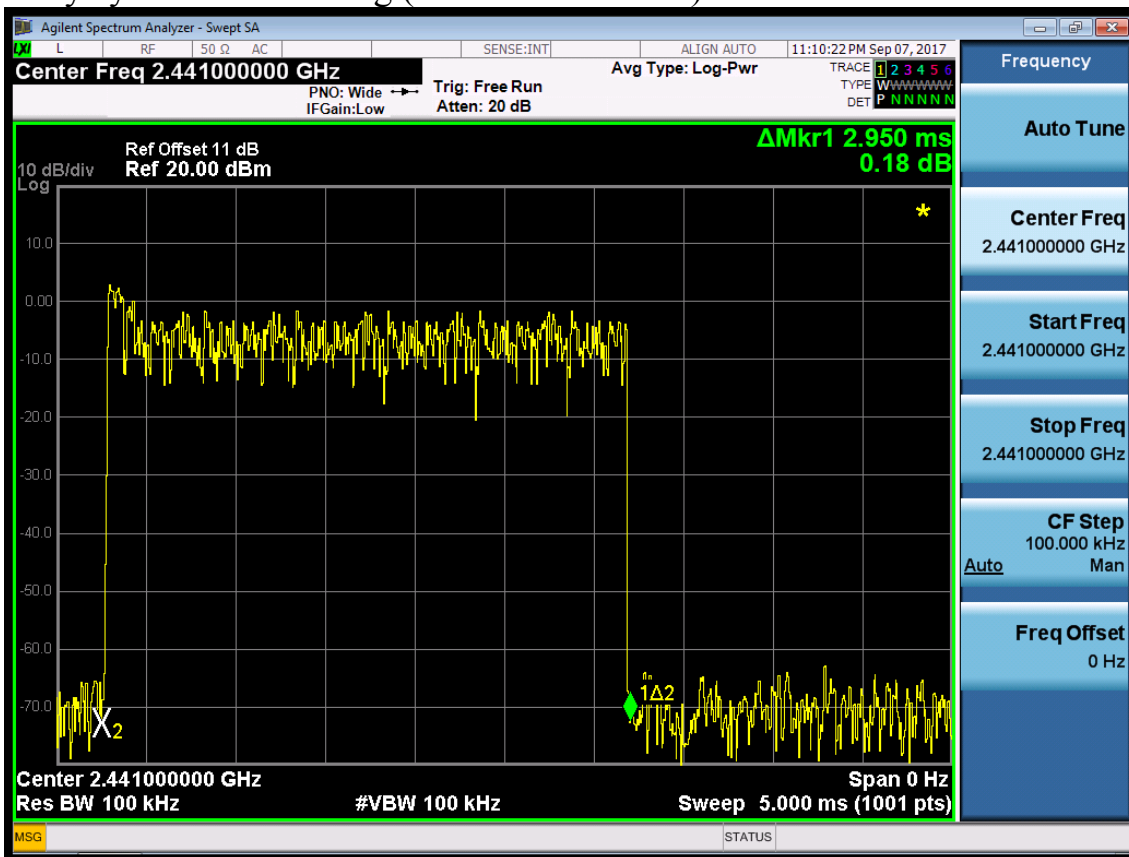

Frequency: 30MHz~1GHz

Data: 1

File: E:\2017 Report Data\B\BYD\ACS17Q1488-FCC.EM6 (14)

Date: 2017-09-19

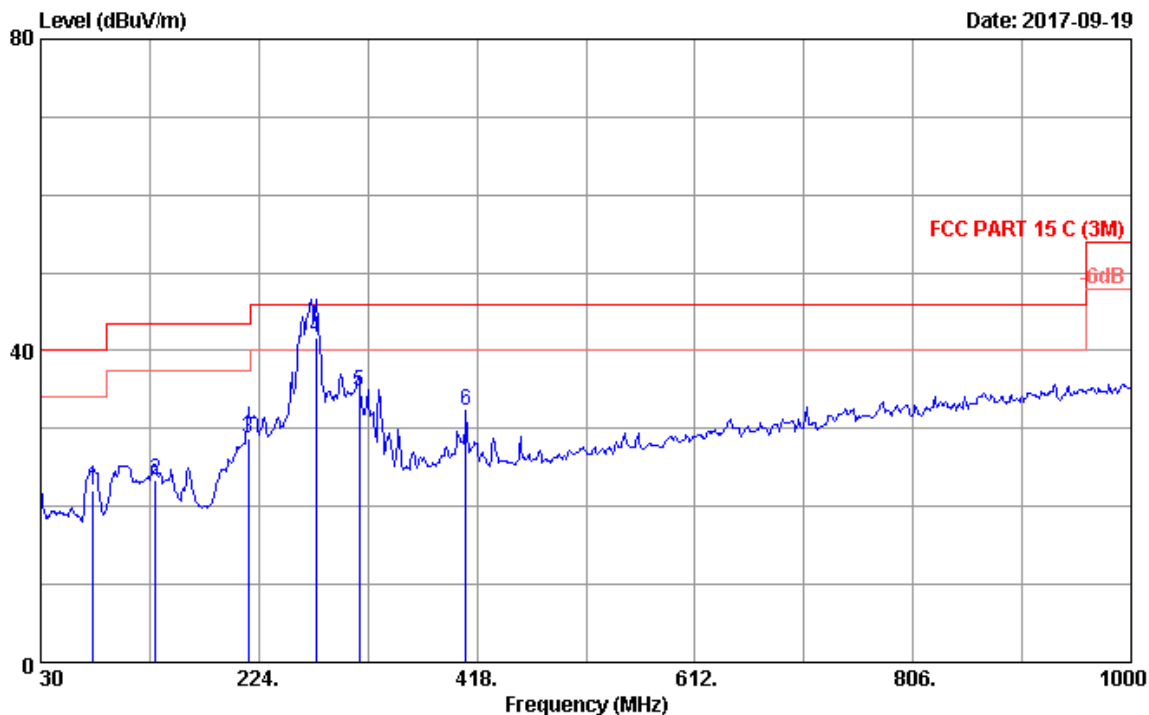

Site no. : 3m Chamber Data no. : 1
 Dis. / Ant. : 3m 2017 9168-493 Ant. pol. : HORIZONTAL
 Limit : FCC PART 15 C (3M)
 Env. / Ins. : 23.4°C/53.6% Engineer : Lynn
 EUT : Notebook M/N:RZ09-0239
 Power rating : DC 20V From Adaptor Input AC 120V/60Hz
 Test Mode : Tx Mode

No.	Freq. (MHz)	Ant. Factor (dB/m)	Cable Loss (dB)	Reading (dBuV)	Emission Level (dBuV/m)	Limits (dBuV/m)	Margin (dB)	Remark
1	76.560	16.07	0.96	5.13	22.16	40.00	17.84	QP
2	131.850	18.60	1.27	3.59	23.46	43.50	20.04	QP
3	214.300	16.90	1.73	10.04	28.67	43.50	14.83	QP
4	274.440	19.24	2.09	20.23	41.56	46.00	4.44	QP
5	313.240	20.21	2.33	12.14	34.68	46.00	11.32	QP
6	408.300	22.36	2.91	7.09	32.36	46.00	13.64	QP

Remarks: 1. Emission Level= Antenna Factor + Cable Loss + Reading.
 2. The emission levels that are 20dB below the official limit are not reported.

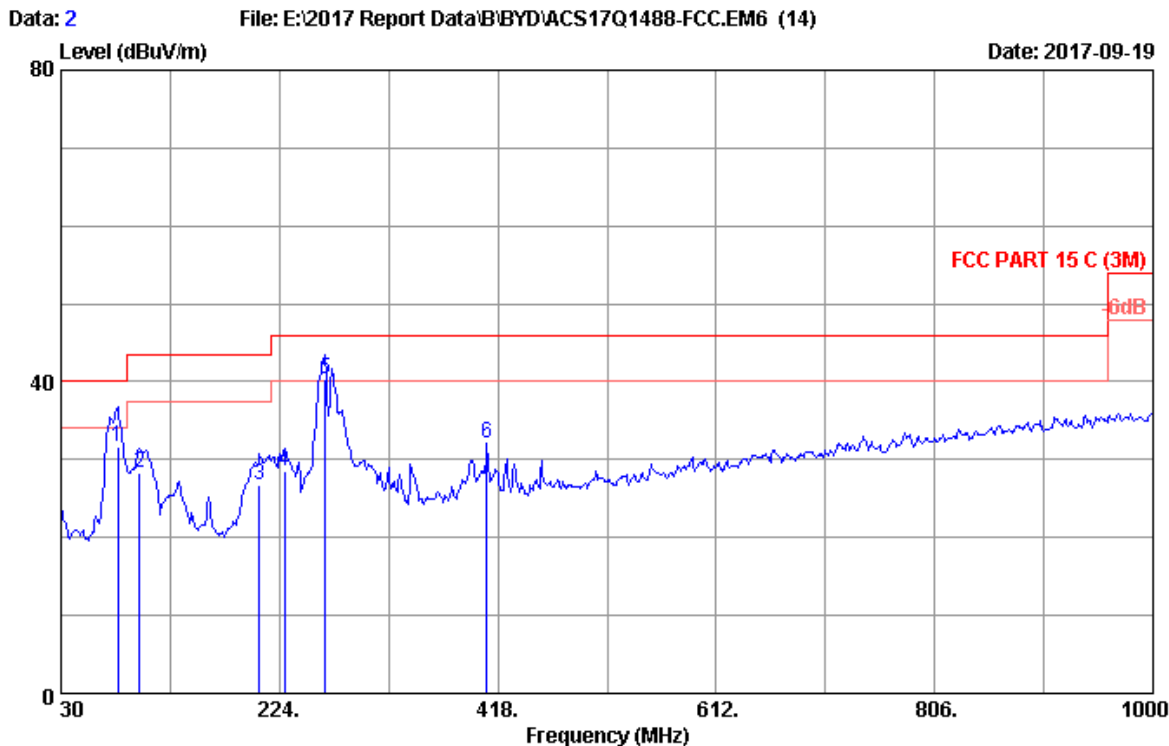

Site no. : 3m Chamber Data no. : 2
 Dis. / Ant. : 3m 2017 9168-493 Ant. pol. : VERTICAL
 Limit : FCC PART 15 C (3M)
 Env. / Ins. : 23.4°C/53.6% Engineer : Lynn
 EUT : Notebook M/N:RZ09-0239
 Power rating : DC 20V From Adaptor Input AC 120V/60Hz
 Test Mode : Tx Mode

No.	Freq. (MHz)	Ant. Factor (dB/m)	Cable Loss (dB)	Reading (dBuV)	Emission Level (dBuV/m)	Limits (dBuV/m)	Margin (dB)	Remark
1	80.440	15.20	0.98	15.54	31.72	40.00	8.28	QP
2	99.840	14.80	1.10	12.46	28.36	43.50	15.14	QP
3	206.540	16.90	1.68	8.15	26.73	43.50	16.77	QP
4	228.850	17.44	1.82	9.27	28.53	46.00	17.47	QP
5	264.740	18.81	2.03	19.59	40.43	46.00	5.57	QP
6	408.300	22.36	2.91	6.75	32.02	46.00	13.98	QP

Remarks: 1. Emission Level= Antenna Factor + Cable Loss + Reading.
 2. The emission levels that are 20dB below the official limit are not reported.

Frequency: 1GHz~18GHz

Data: 1 File: F:\2017 Report\B\BYD\ACS17Q1488-BT3.0-FCC.EM6 (32) Date: 2017-09-19

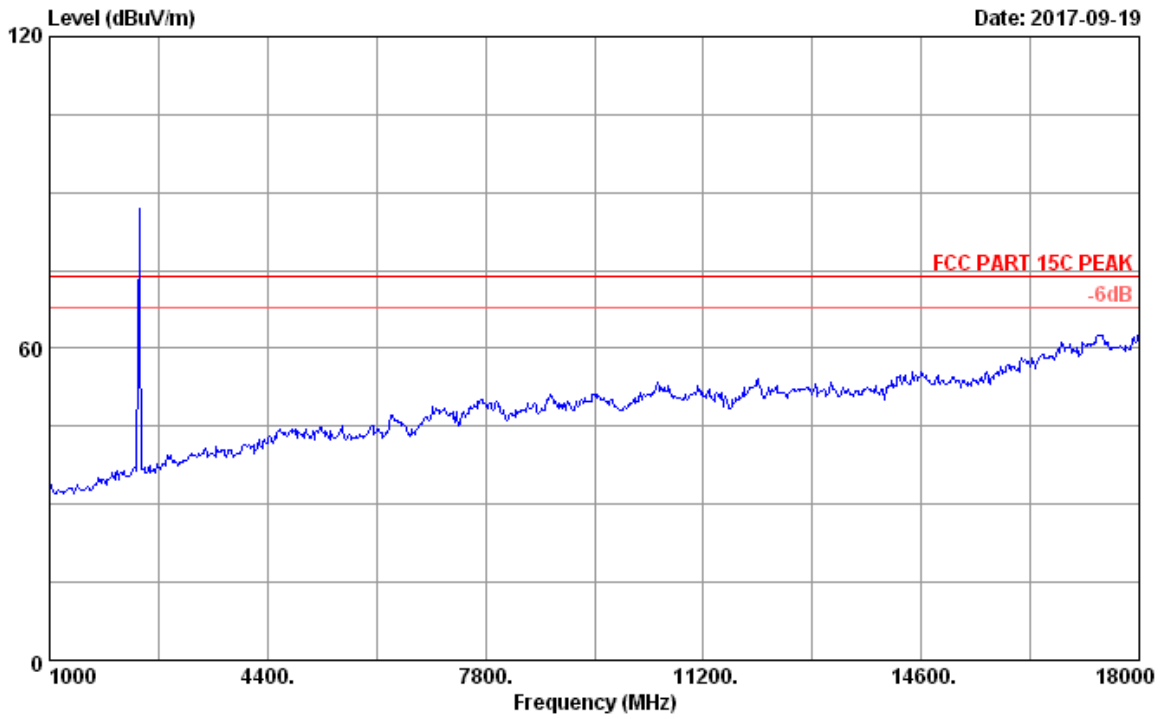

Site no.	: 3m Chamber	Data no.	: 1
Dis. / Ant.	: 3m 2017 ANT 3006 HF	Ant. pol.	: VERTICAL
Limit	: FCC PART 15C PEAK		
Env. / Ins.	: 23.1°C/52.8%	Engineer	: Lynn
EUT	: Notebook M/N:RZ09-0239		
Power rating	: DC 20V From Adaptor Input AC 120V/60Hz		
Test Mode	: GFSK 2402 Tx Mode		

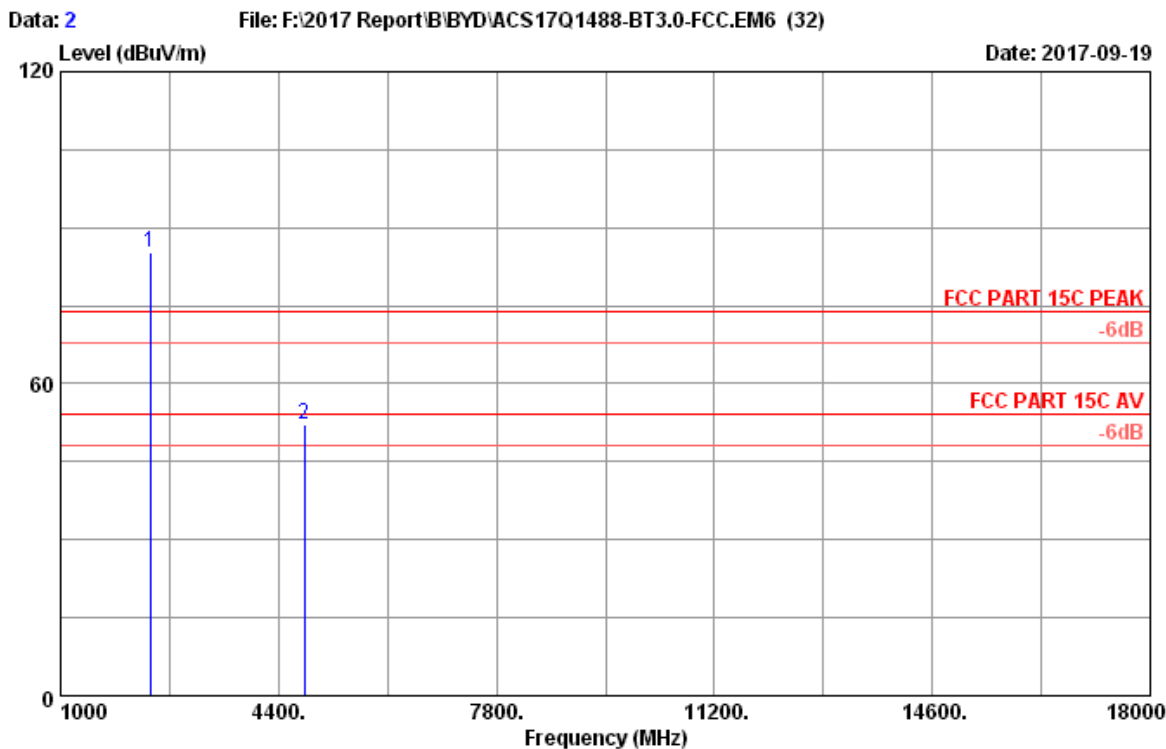

Site no. : 3m Chamber Data no. : 2
 Dis. / Ant. : 3m 2017 ANT 3006 HF Ant. pol. : VERTICAL
 Limit : FCC PART 15C PEAK
 Env. / Ins. : 23.1°C/52.8% Engineer : Lynn
 EUT : Notebook M/N:RZ09-0239
 Power rating : DC 20V From Adaptor Input AC 120V/60Hz
 Test Mode : GFSK 2402 Tx Mode

No.	Freq. (MHz)	Ant. Factor (dB/m)	Cable Loss (dB)	Reading (dBuV)	Amp factor (dB)	Emission Level (dBuV/m)	Limits (dBuV/m)	Margin (dB)	Remark
1	2402.00	27.96	7.88	84.71	35.33	85.22	74.00	-11.22	Peak
2	4804.00	33.42	12.07	42.32	35.65	52.16	74.00	21.84	Peak

Remarks: 1. Emission Level= Antenna Factor + Cable Loss + Reading -Amp factor.
 2. The emission levels that are 20dB below the official limit are not reported.

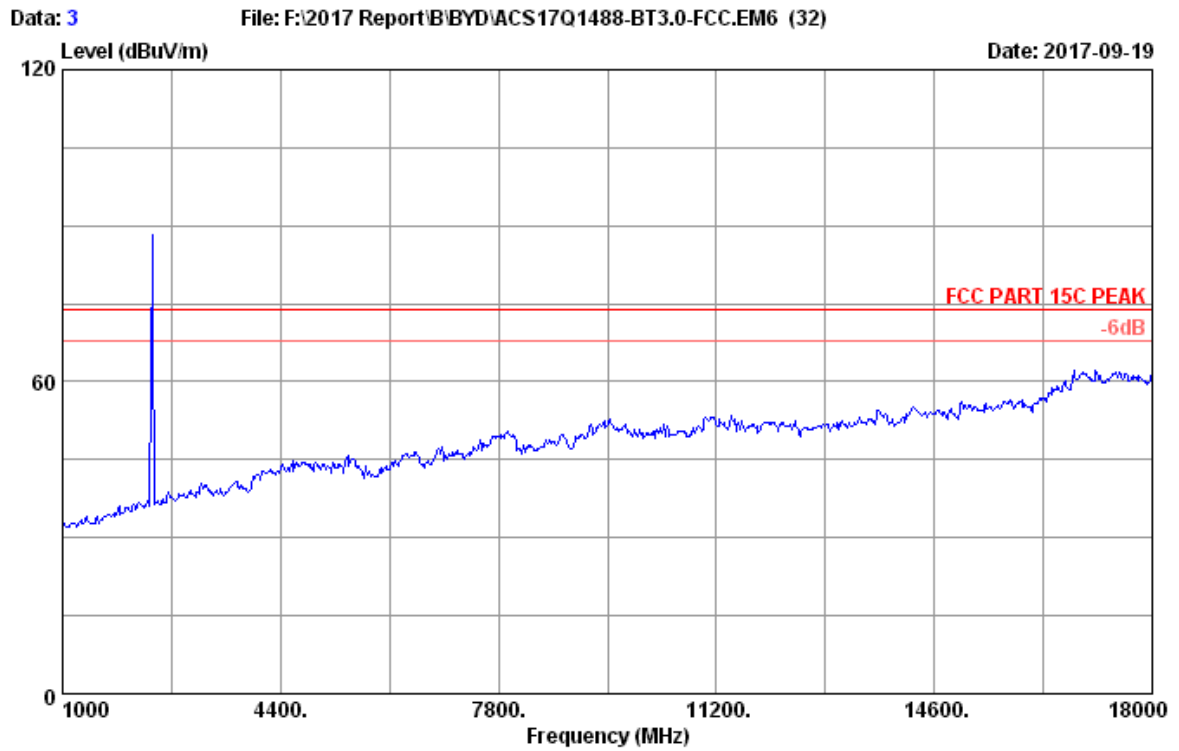

Site no. : 3m Chamber Data no. : 3
Dis. / Ant. : 3m 2017 ANT 3006 HF Ant. pol. : HORIZONTAL
Limit : FCC PART 15C PEAK
Env. / Ins. : 23.1°C/52.8% Engineer : Lynn
EUT : Notebook M/N:RZ09-0239
Power rating : DC 20V From Adaptor Input AC 120V/60Hz
Test Mode : GFSK 2402 Tx Mode



Site no. : 3m Chamber Data no. : 4
 Dis. / Ant. : 3m 2017 ANT 3006 HF Ant. pol. : HORIZONTAL
 Limit : FCC PART 15C PEAK
 Env. / Ins. : 23.1°C/52.8% Engineer : Lynn
 EUT : Notebook M/N:RZ09-0239
 Power rating : DC 20V From Adaptor Input AC 120V/60Hz
 Test Mode : GFSK 2402 Tx Mode

No.	Freq. (MHz)	Ant. Factor (dB/m)	Cable Loss (dB)	Reading (dBuV)	Amp factor (dB)	Emission Level (dBuV/m)	Limits (dBuV/m)	Margin (dB)	Remark
1	2402.00	27.96	7.88	88.45	35.33	88.96	74.00	-14.96	Peak
2	4804.00	33.42	12.07	42.08	35.65	51.92	74.00	22.08	Peak

Remarks: 1. Emission Level= Antenna Factor + Cable Loss + Reading -Amp factor.
 2. The emission levels that are 20dB below the official limit are not reported.

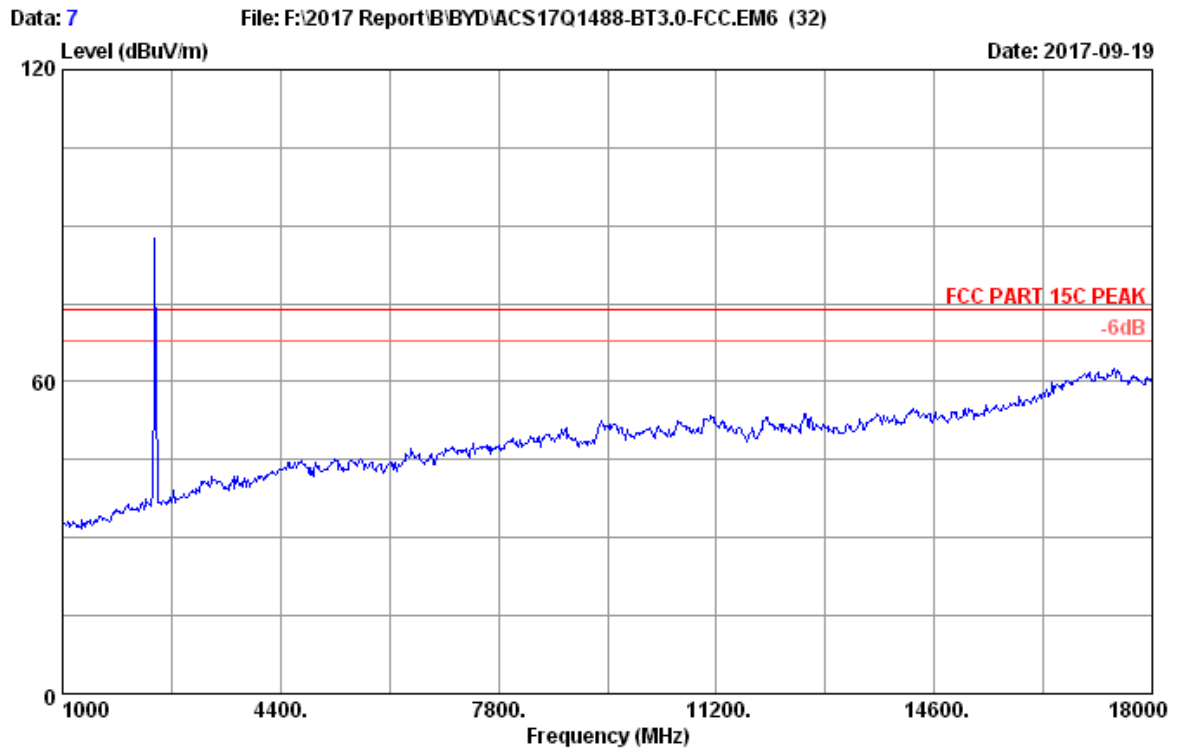

Site no. : 3m Chamber Data no. : 7
Dis. / Ant. : 3m 2017 ANT 3006 HF Ant. pol. : VERTICAL
Limit : FCC PART 15C PEAK
Env. / Ins. : 23.1°C/52.8% Engineer : Lynn
EUT : Notebook M/N:RZ09-0239
Power rating : DC 20V From Adaptor Input AC 120V/60Hz
Test Mode : GFSK 2441 Tx Mode

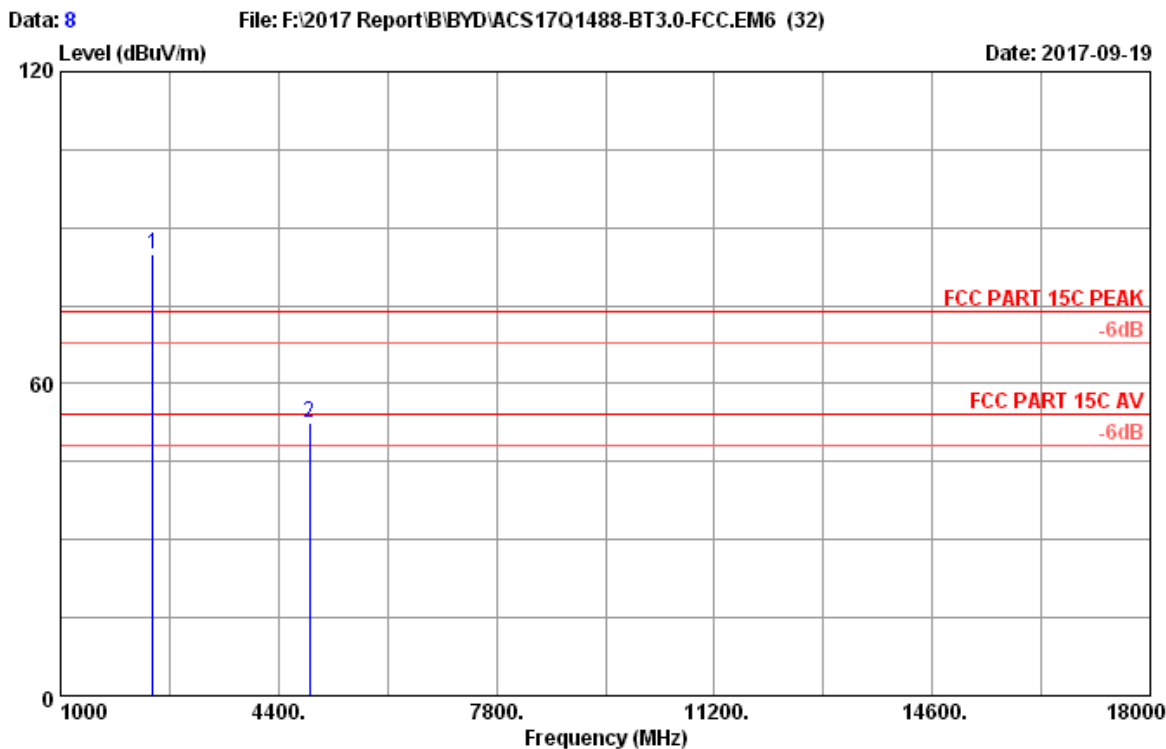

Site no. : 3m Chamber Data no. : 8
 Dis. / Ant. : 3m 2017 ANT 3006 HF Ant. pol. : VERTICAL
 Limit : FCC PART 15C PEAK
 Env. / Ins. : 23.1*C/52.8% Engineer : Lynn
 EUT : Notebook M/N:RZ09-0239
 Power rating : DC 20V From Adaptor Input AC 120V/60Hz
 Test Mode : GFSK 2441 Tx Mode

No.	Freq. (MHz)	Ant. Factor (dB/m)	Cable Loss (dB)	Reading (dBuV)	Amp factor (dB)	Emission Level (dBuV/m)	Limits (dBuV/m)	Margin (dB)	Remark
1	2441.00	28.03	7.95	84.27	35.33	84.92	74.00	-10.92	Peak
2	4882.00	33.56	12.22	42.39	35.64	52.53	74.00	21.47	Peak

Remarks: 1. Emission Level= Antenna Factor + Cable Loss + Reading -Amp factor.
 2. The emission levels that are 20dB below the official limit are not reported.

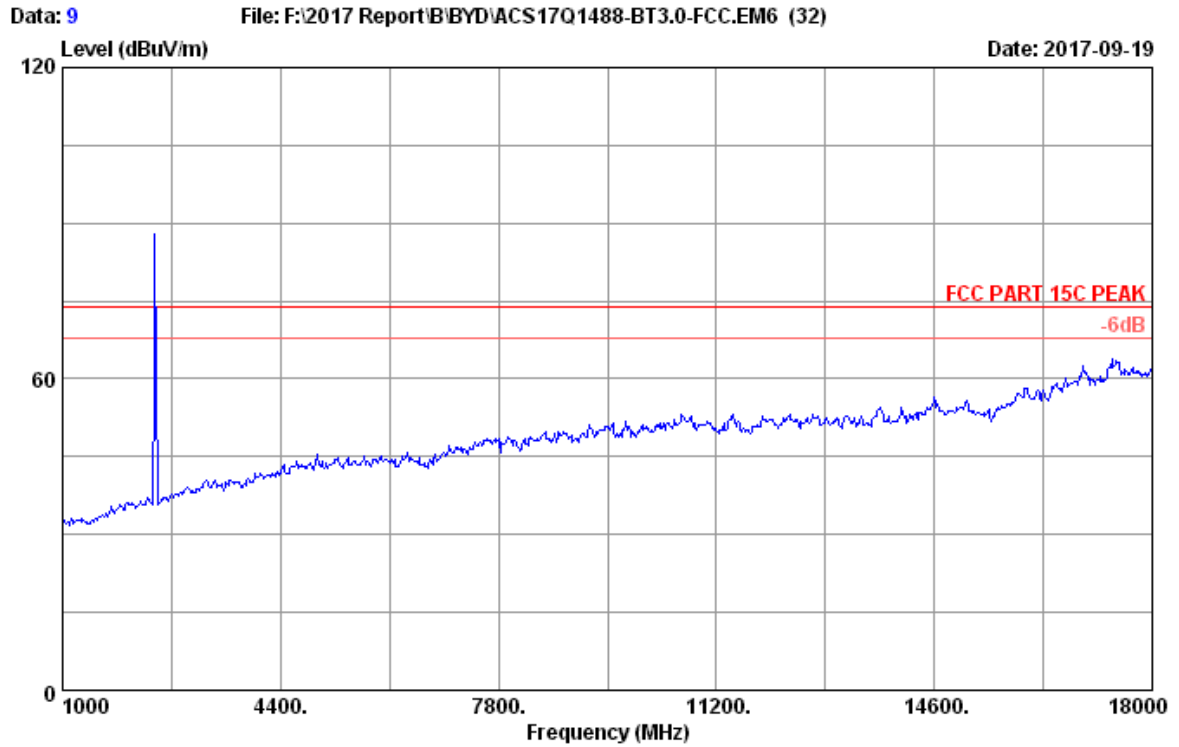

Site no. : 3m Chamber Data no. : 9
Dis. / Ant. : 3m 2017 ANT 3006 HF Ant. pol. : HORIZONTAL
Limit : FCC PART 15C PEAK
Env. / Ins. : 23.1*C/52.8% Engineer : Lynn
EUT : Notebook M/N:RZ09-0239
Power rating : DC 20V From Adaptor Input AC 120V/60Hz
Test Mode : GFSK 2441 Tx Mode

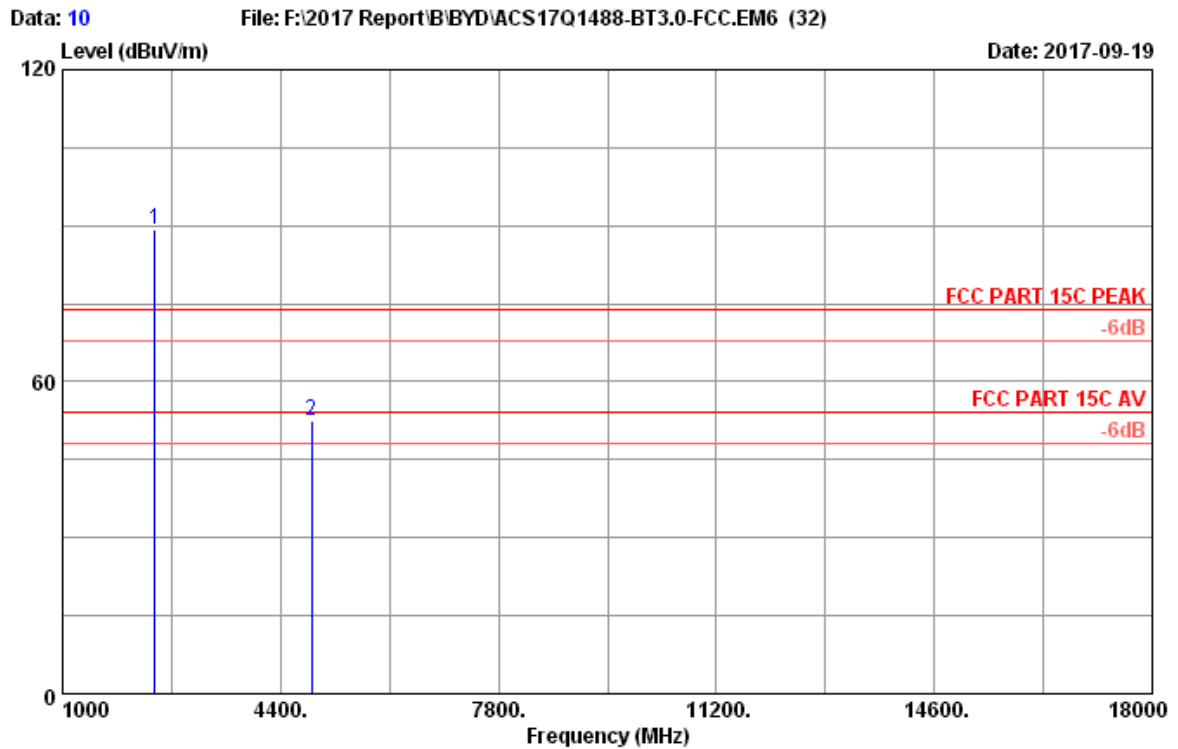

Site no. : 3m Chamber Data no. : 10
 Dis. / Ant. : 3m 2017 ANT 3006 HF Ant. pol. : HORIZONTAL
 Limit : FCC PART 15C PEAK
 Env. / Ins. : 23.1°C/52.8% Engineer : Lynn
 EUT : Notebook M/N:RZ09-0239
 Power rating : DC 20V From Adaptor Input AC 120V/60Hz
 Test Mode : GFSK 2441 Tx Mode

No.	Freq. (MHz)	Ant. Factor (dB/m)	Cable Loss (dB)	Reading (dBuV)	Amp factor (dB)	Emission Level (dBuV/m)	Limits (dBuV/m)	Margin (dB)	Remark
1	2441.00	28.03	7.95	88.61	35.33	89.26	74.00	-15.26	Peak
2	4882.00	33.56	12.22	42.18	35.64	52.32	74.00	21.68	Peak

Remarks: 1. Emission Level= Antenna Factor + Cable Loss + Reading -Amp factor.
 2. The emission levels that are 20dB below the official limit are not reported.

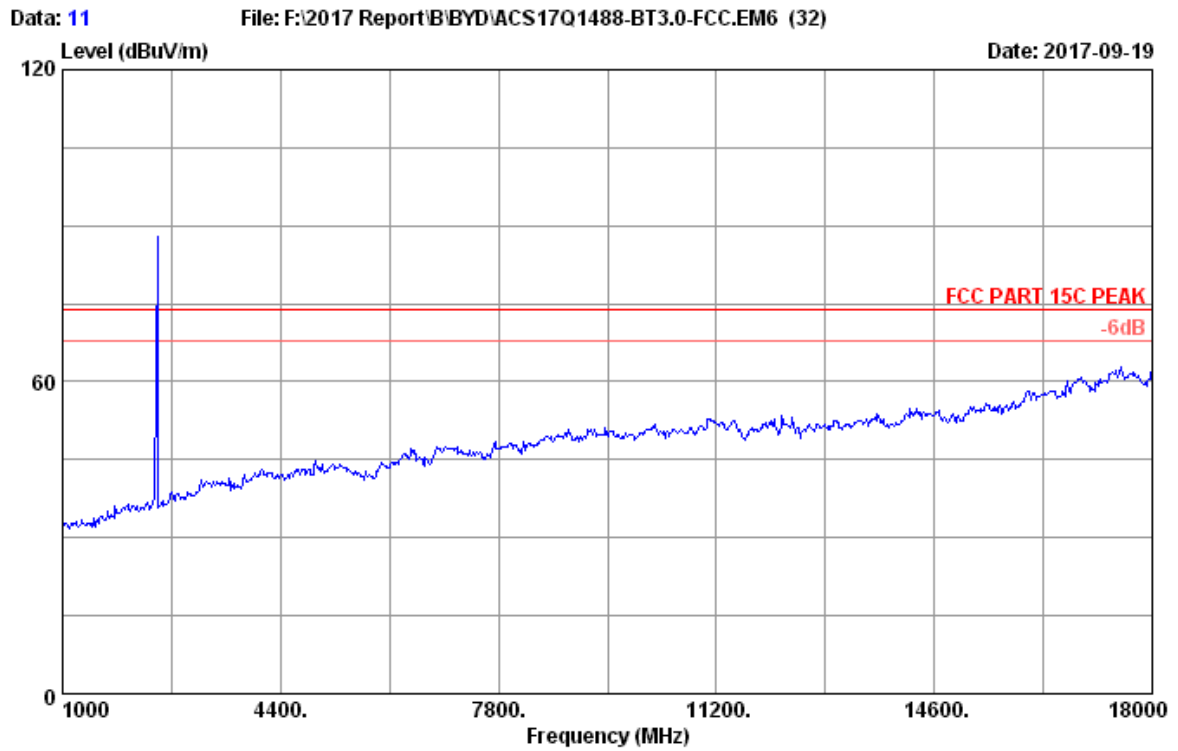

Site no. : 3m Chamber Data no. : 11
Dis. / Ant. : 3m 2017 ANT 3006 HF Ant. pol. : HORIZONTAL
Limit : FCC PART 15C PEAK
Env. / Ins. : 23.1°C/52.8% Engineer : Lynn
EUT : Notebook M/N:RZ09-0239
Power rating : DC 20V From Adaptor Input AC 120V/60Hz
Test Mode : GFSK 2480 Tx Mode

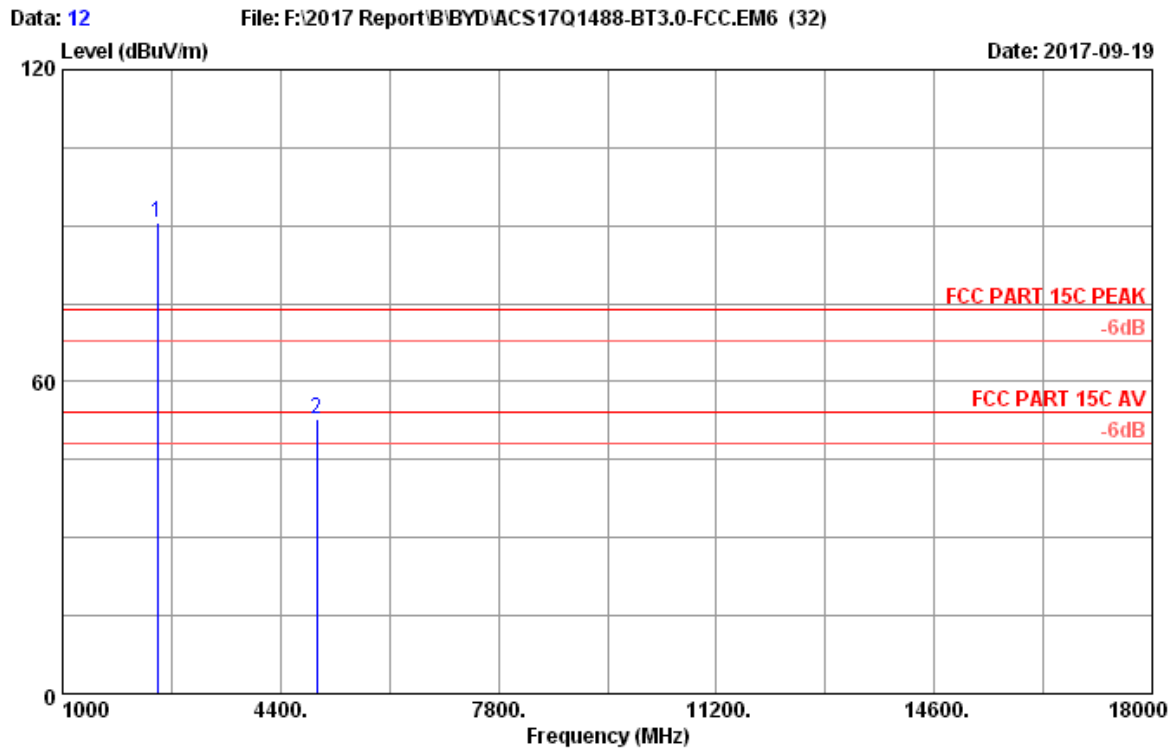

Site no. : 3m Chamber Data no. : 12
 Dis. / Ant. : 3m 2017 ANT 3006 HF Ant. pol. : HORIZONTAL
 Limit : FCC PART 15C PEAK
 Env. / Ins. : 23.1°C/52.8% Engineer : Lynn
 EUT : Notebook M/N:RZ09-0239
 Power rating : DC 20V From Adaptor Input AC 120V/60Hz
 Test Mode : GFSK 2480 Tx Mode

No.	Freq. (MHz)	Ant. Factor (dB/m)	Cable Loss (dB)	Reading (dBuV)	Amp factor (dB)	Emission Level (dBuV/m)	Limits (dBuV/m)	Margin (dB)	Remark
1	2480.00	28.08	8.02	89.82	35.34	90.58	74.00	-16.58	Peak
2	4960.00	33.73	12.38	42.27	35.63	52.75	74.00	21.25	Peak

Remarks: 1. Emission Level= Antenna Factor + Cable Loss + Reading - Amp factor.
 2. The emission levels that are 20dB below the official limit are not reported.

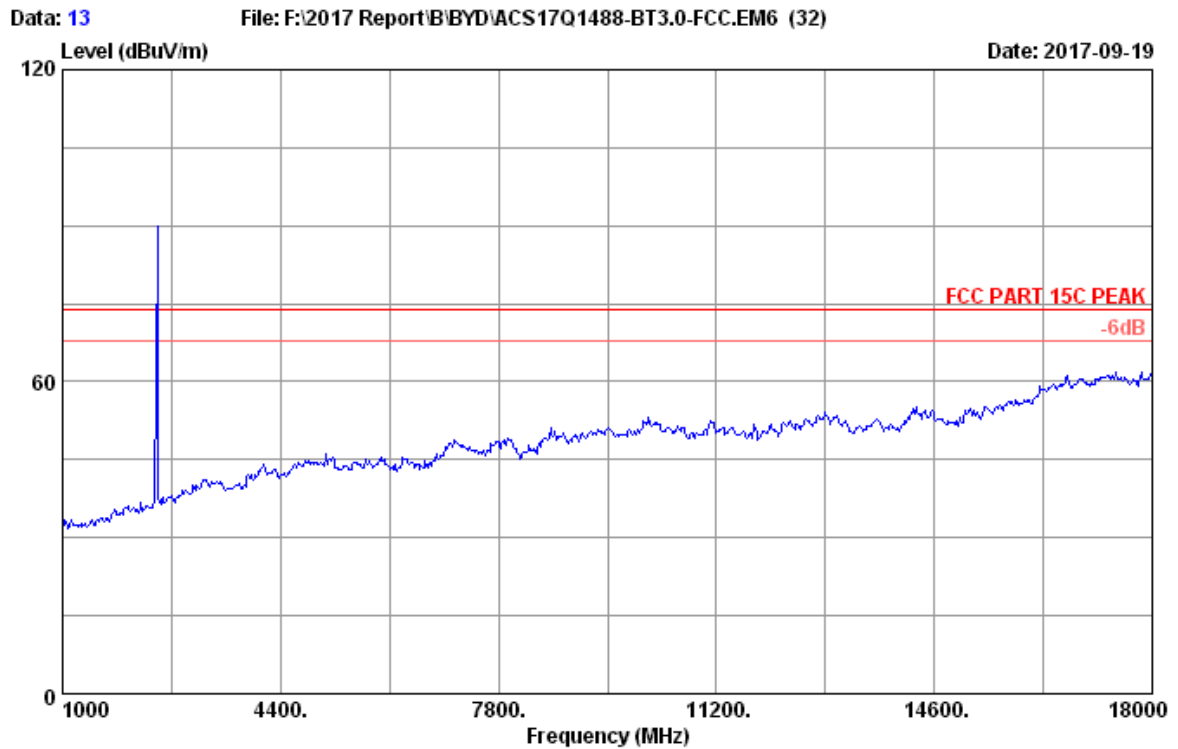

Site no. : 3m Chamber Data no. : 13
Dis. / Ant. : 3m 2017 ANT 3006 HF Ant. pol. : VERTICAL
Limit : FCC PART 15C PEAK
Env. / Ins. : 23.1°C/52.8% Engineer : Lynn
EUT : Notebook M/N:RZ09-0239
Power rating : DC 20V From Adaptor Input AC 120V/60Hz
Test Mode : GFSK 2480 Tx Mode

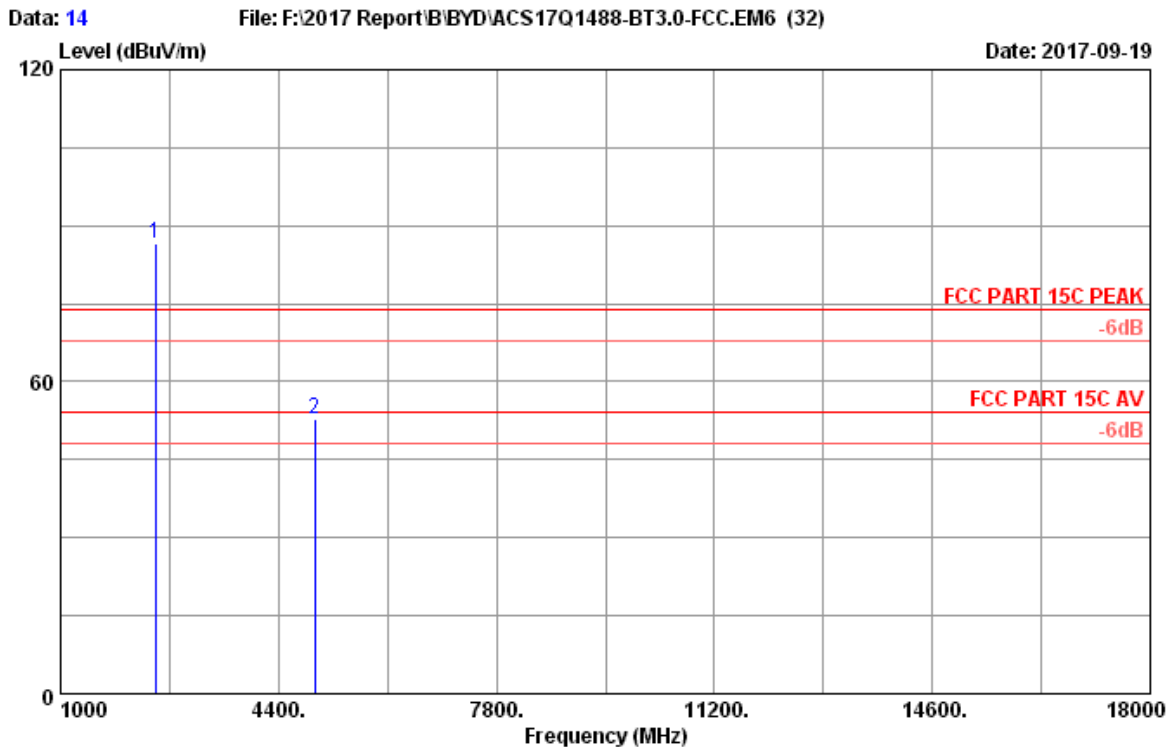

Site no. : 3m Chamber Data no. : 14
 Dis. / Ant. : 3m 2017 ANT 3006 HF Ant. pol. : VERTICAL
 Limit : FCC PART 15C PEAK
 Env. / Ins. : 23.1*C/52.8% Engineer : Lynn
 EUT : Notebook M/N:RZ09-0239
 Power rating : DC 20V From Adaptor Input AC 120V/60Hz
 Test Mode : GFSK 2480 Tx Mode

No.	Freq. (MHz)	Ant. Factor (dB/m)	Cable Loss (dB)	Reading (dBuV)	Amp factor (dB)	Emission Level (dBuV/m)	Limits (dBuV/m)	Margin (dB)	Remark
1	2480.00	28.08	8.02	85.68	35.34	86.44	74.00	-12.44	Peak
2	4960.00	33.73	12.38	42.34	35.63	52.82	74.00	21.18	Peak

Remarks: 1. Emission Level= Antenna Factor + Cable Loss + Reading -Amp factor.
 2. The emission levels that are 20dB below the official limit are not reported.

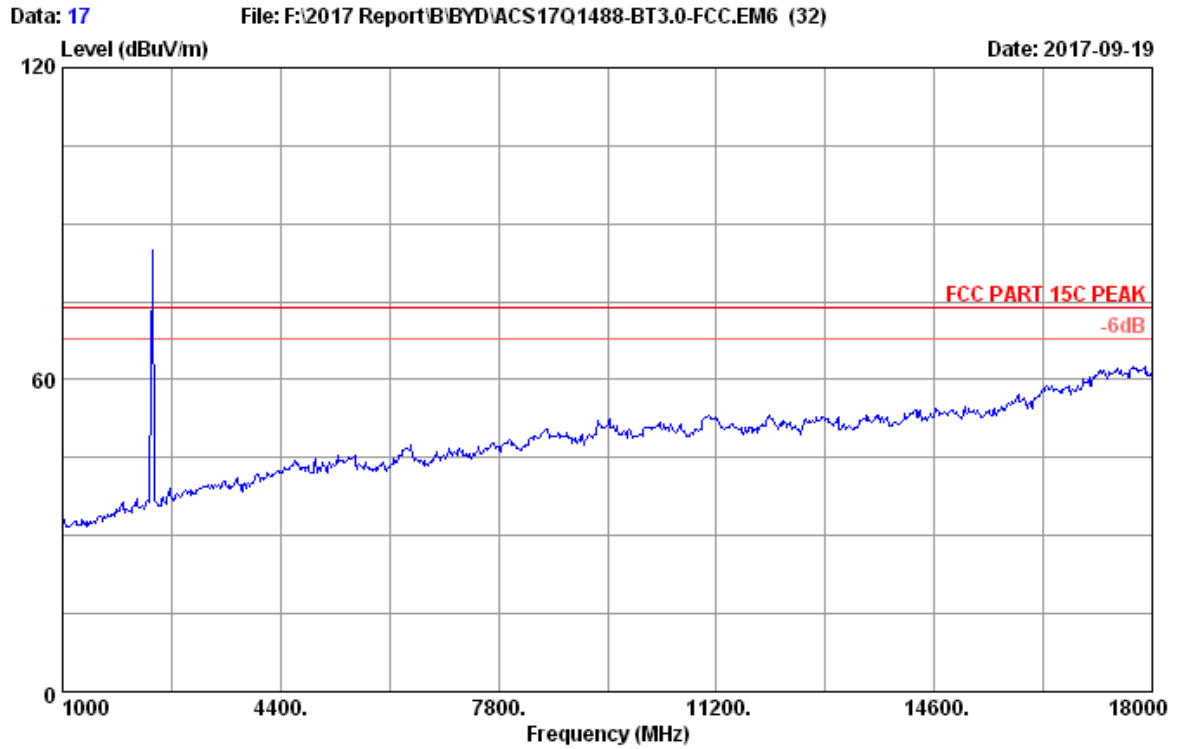

Site no. : 3m Chamber Data no. : 17
Dis. / Ant. : 3m 2017 ANT 3006 HF Ant. pol. : VERTICAL
Limit : FCC PART 15C PEAK
Env. / Ins. : 23.1°C/52.8% Engineer : Lynn
EUT : Notebook M/N:RZ09-0239
Power rating : DC 20V From Adaptor Input AC 120V/60Hz
Test Mode : 8-DPSK 2402 Tx Mode

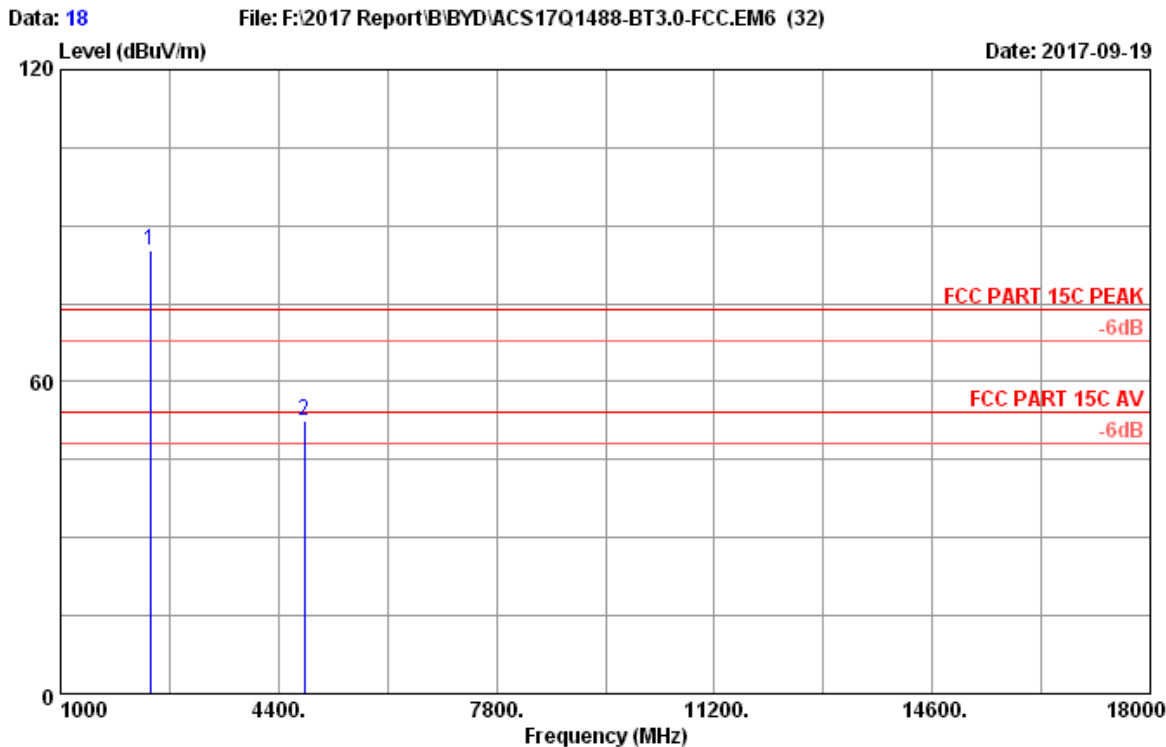

Site no. : 3m Chamber Data no. : 18
 Dis. / Ant. : 3m 2017 ANT 3006 HF Ant. pol. : VERTICAL
 Limit : FCC PART 15C PEAK
 Env. / Ins. : 23.1°C/52.8% Engineer : Lynn
 EUT : Notebook M/N:RZ09-0239
 Power rating : DC 20V From Adaptor Input AC 120V/60Hz
 Test Mode : 8-DPSK 2402 Tx Mode

No.	Freq. (MHz)	Ant. Factor (dB/m)	Cable Loss (dB)	Reading (dBuV)	Amp factor (dB)	Emission Level (dBuV/m)	Limits (dBuV/m)	Margin (dB)	Remark
1	2402.00	27.96	7.88	84.73	35.33	85.24	74.00	-11.24	Peak
2	4804.00	33.42	12.07	42.66	35.65	52.50	74.00	21.50	Peak

Remarks: 1. Emission Level= Antenna Factor + Cable Loss + Reading -Amp factor.
 2. The emission levels that are 20dB below the official limit are not reported.

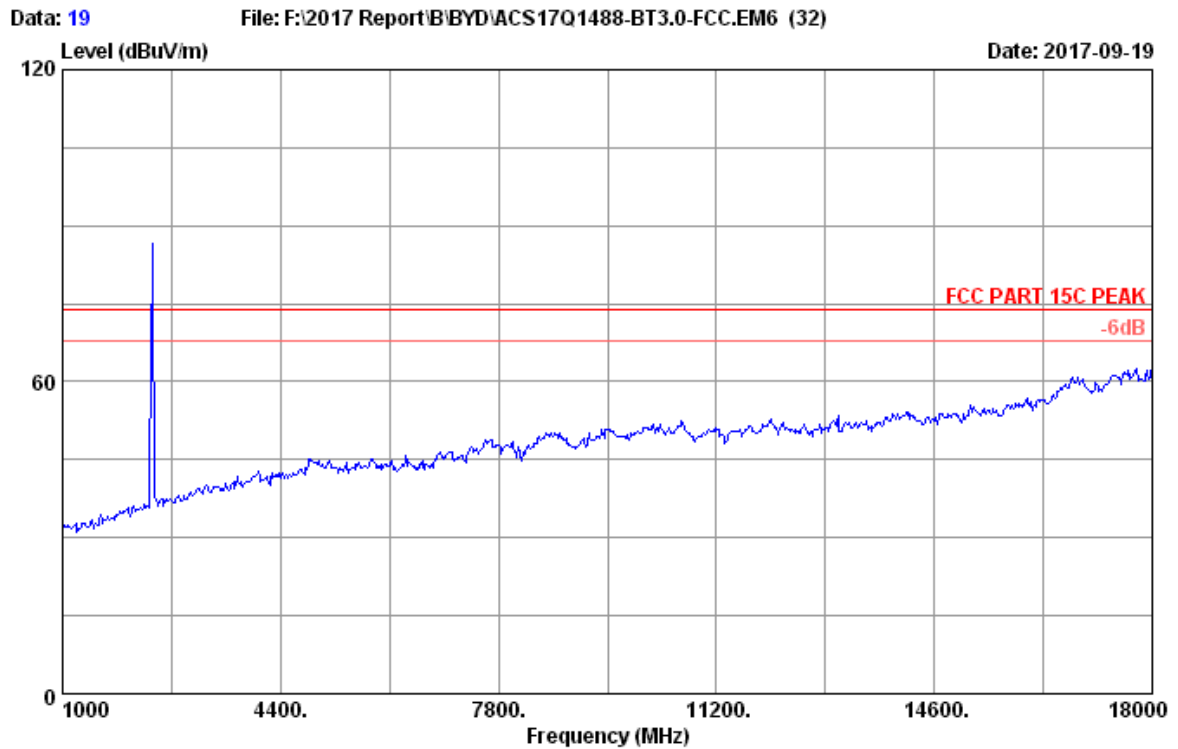

Site no. : 3m Chamber Data no. : 19
Dis. / Ant. : 3m 2017 ANT 3006 HF Ant. pol. : HORIZONTAL
Limit : FCC PART 15C PEAK
Env. / Ins. : 23.1°C/52.8% Engineer : Lynn
EUT : Notebook M/N:RZ09-0239
Power rating : DC 20V From Adaptor Input AC 120V/60Hz
Test Mode : 8-DPSK 2402 Tx Mode

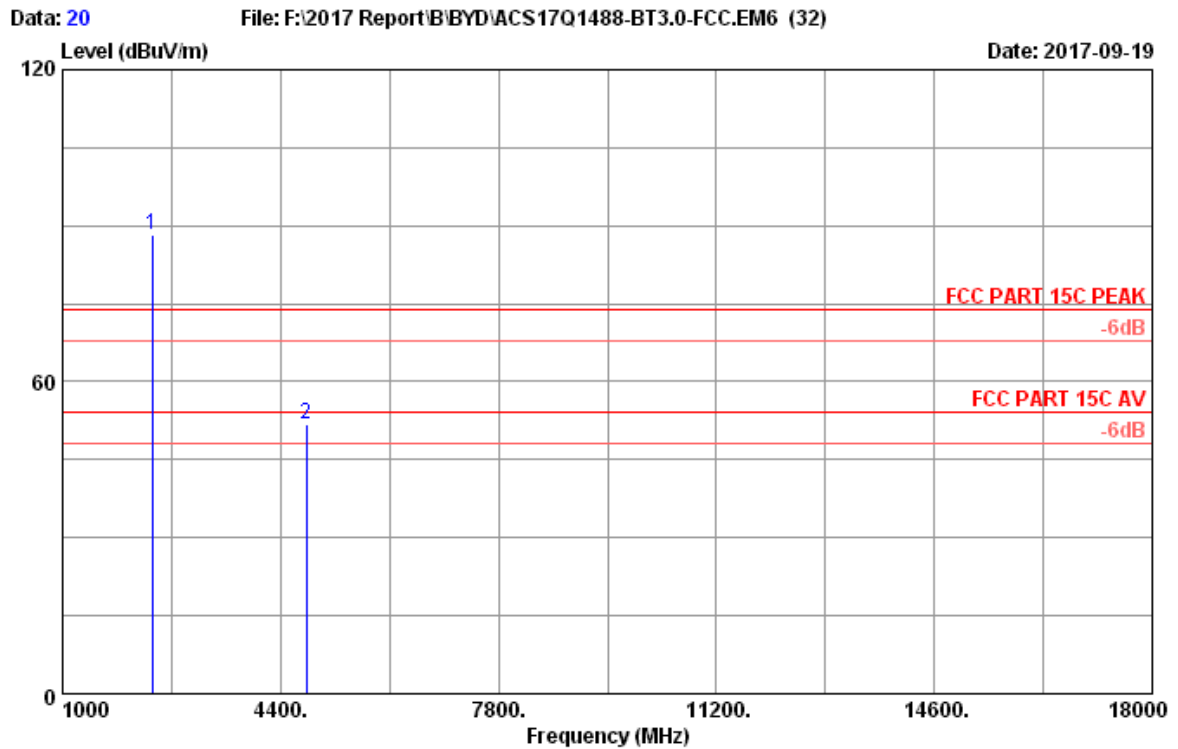

Site no. : 3m Chamber Data no. : 20
 Dis. / Ant. : 3m 2017 ANT 3006 HF Ant. pol. : HORIZONTAL
 Limit : FCC PART 15C PEAK
 Env. / Ins. : 23.1°C/52.8% Engineer : Lynn
 EUT : Notebook M/N:RZ09-0239
 Power rating : DC 20V From Adaptor Input AC 120V/60Hz
 Test Mode : 8-DPSK 2402 Tx Mode

No.	Freq. (MHz)	Ant. Factor (dB/m)	Cable Loss (dB)	Reading (dBuV)	Amp factor (dB)	Emission Level (dBuV/m)	Limits (dBuV/m)	Margin (dB)	Remark
1	2402.00	27.96	7.88	87.57	35.33	88.08	74.00	-14.08	Peak
2	4804.00	33.42	12.07	42.06	35.65	51.90	74.00	22.10	Peak

Remarks: 1. Emission Level= Antenna Factor + Cable Loss + Reading -Amp factor.
 2. The emission levels that are 20dB below the official limit are not reported.

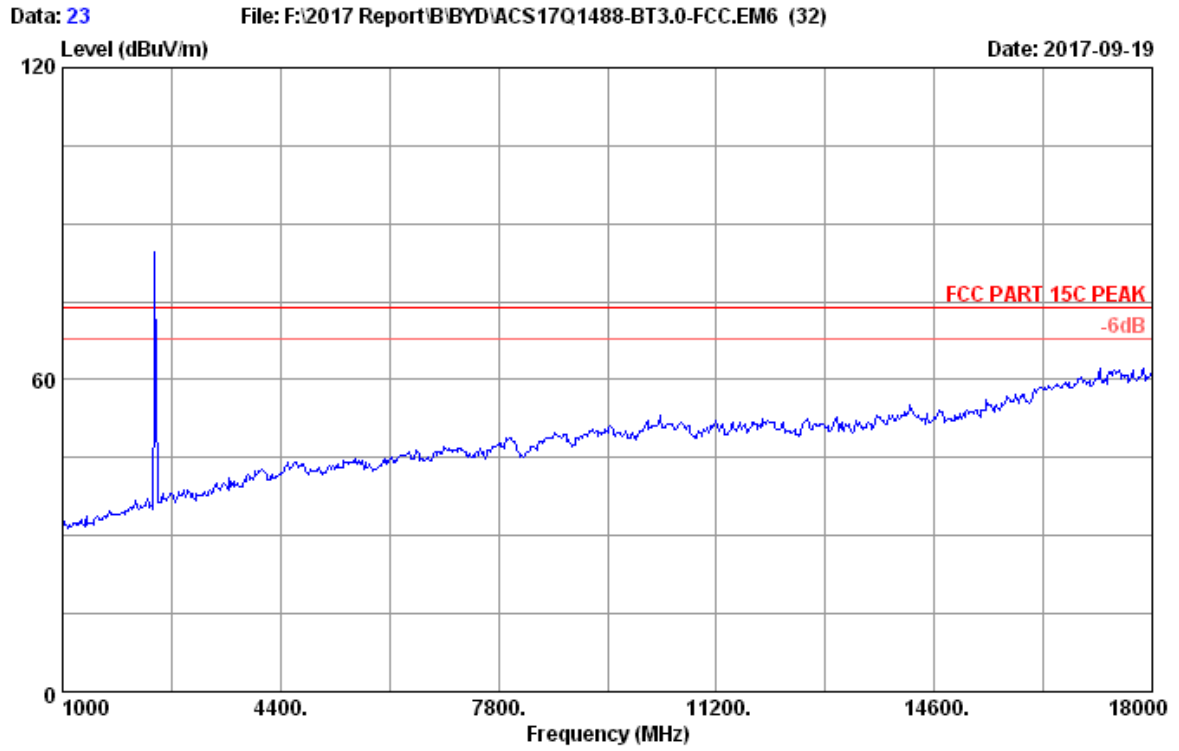

Site no. : 3m Chamber Data no. : 23
Dis. / Ant. : 3m 2017 ANT 3006 HF Ant. pol. : HORIZONTAL
Limit : FCC PART 15C PEAK
Env. / Ins. : 23.1°C/52.8% Engineer : Lynn
EUT : Notebook M/N:RZ09-0239
Power rating : DC 20V From Adaptor Input AC 120V/60Hz
Test Mode : 8-DPSK 2441 Tx Mode

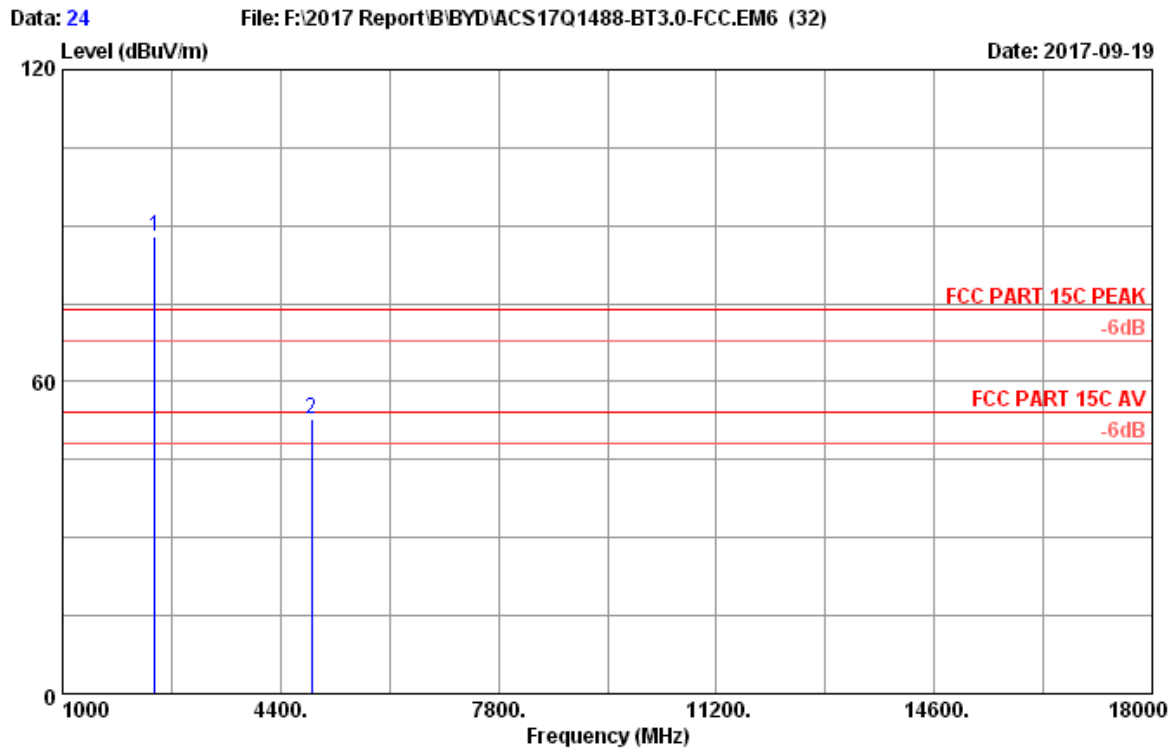

Site no. : 3m Chamber Data no. : 24
 Dis. / Ant. : 3m 2017 ANT 3006 HF Ant. pol. : HORIZONTAL
 Limit : FCC PART 15C PEAK
 Env. / Ins. : 23.1°C/52.8% Engineer : Lynn
 EUT : Notebook M/N:RZ09-0239
 Power rating : DC 20V From Adaptor Input AC 120V/60Hz
 Test Mode : 8-DPSK 2441 Tx Mode

No.	Freq. (MHz)	Ant. Factor (dB/m)	Cable Loss (dB)	Reading (dBuV)	Amp factor (dB)	Emission Level (dBuV/m)	Limits (dBuV/m)	Margin (dB)	Remark
1	2441.00	28.03	7.95	87.34	35.33	87.99	74.00	-13.99	Peak
2	4882.00	33.56	12.22	42.58	35.64	52.72	74.00	21.28	Peak

Remarks: 1. Emission Level= Antenna Factor + Cable Loss + Reading -Amp factor.
 2. The emission levels that are 20dB below the official limit are not reported.

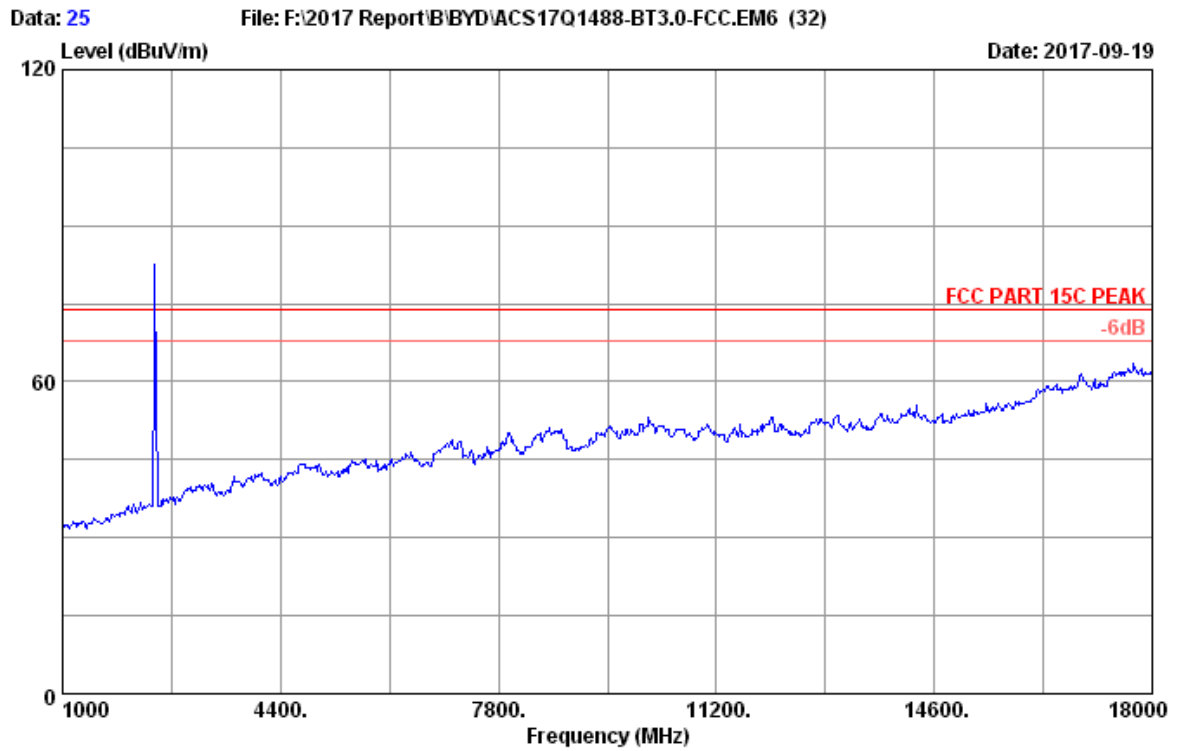

Site no. : 3m Chamber Data no. : 25
Dis. / Ant. : 3m 2017 ANT 3006 HF Ant. pol. : VERTICAL
Limit : FCC PART 15C PEAK
Env. / Ins. : 23.1°C/52.8% Engineer : Lynn
EUT : Notebook M/N:RZ09-0239
Power rating : DC 20V From Adaptor Input AC 120V/60Hz
Test Mode : 8-DPSK 2441 Tx Mode

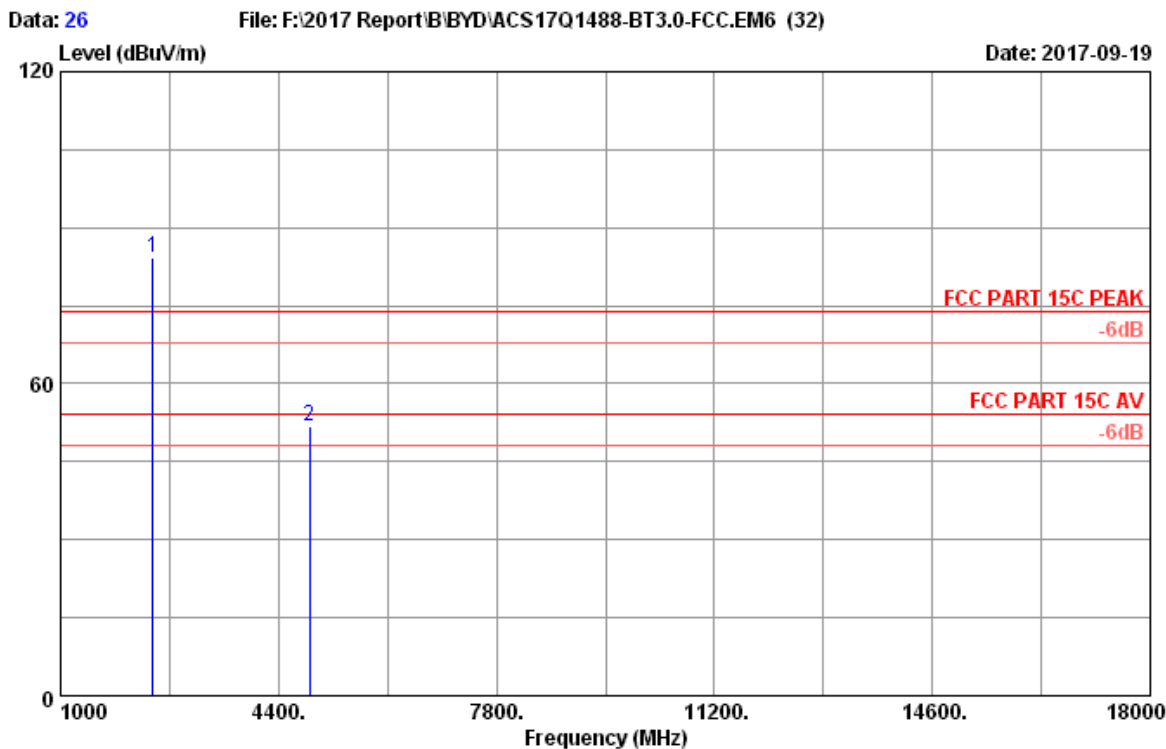

Site no. : 3m Chamber Data no. : 26
 Dis. / Ant. : 3m 2017 ANT 3006 HF Ant. pol. : VERTICAL
 Limit : FCC PART 15C PEAK
 Env. / Ins. : 23.1°C/52.8% Engineer : Lynn
 EUT : Notebook M/N:RZ09-0239
 Power rating : DC 20V From Adaptor Input AC 120V/60Hz
 Test Mode : 8-DPSK 2441 Tx Mode

No.	Freq. (MHz)	Ant. Factor (dB/m)	Cable Loss (dB)	Reading (dBuV)	Amp factor (dB)	Emission Level (dBuV/m)	Limits (dBuV/m)	Margin (dB)	Remark
1	2441.00	28.03	7.95	83.53	35.33	84.18	74.00	-10.18	Peak
2	4882.00	33.56	12.22	41.82	35.64	51.96	74.00	22.04	Peak

Remarks: 1. Emission Level= Antenna Factor + Cable Loss + Reading -Amp factor.
 2. The emission levels that are 20dB below the official limit are not reported.

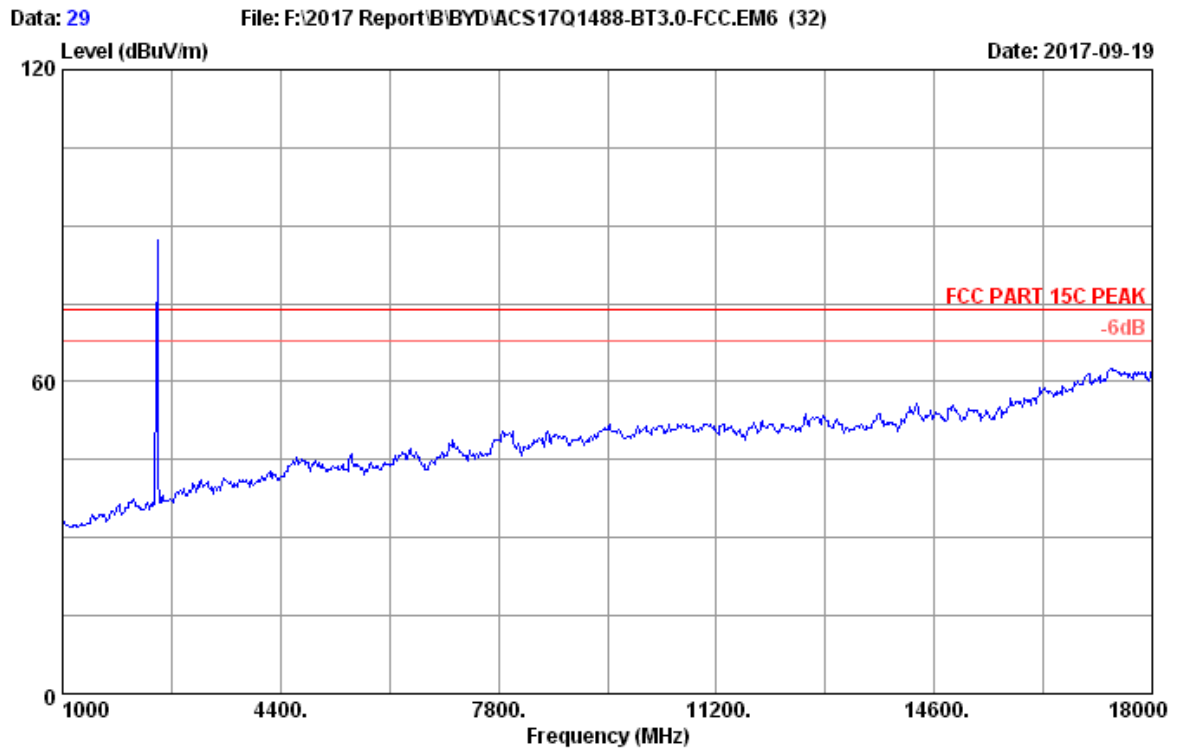

Site no. : 3m Chamber Data no. : 29
Dis. / Ant. : 3m 2017 ANT 3006 HF Ant. pol. : VERTICAL
Limit : FCC PART 15C PEAK
Env. / Ins. : 23.1°C/52.8% Engineer : Lynn
EUT : Notebook M/N:RZ09-0239
Power rating : DC 20V From Adaptor Input AC 120V/60Hz
Test Mode : 8-DPSK 2480 Tx Mode

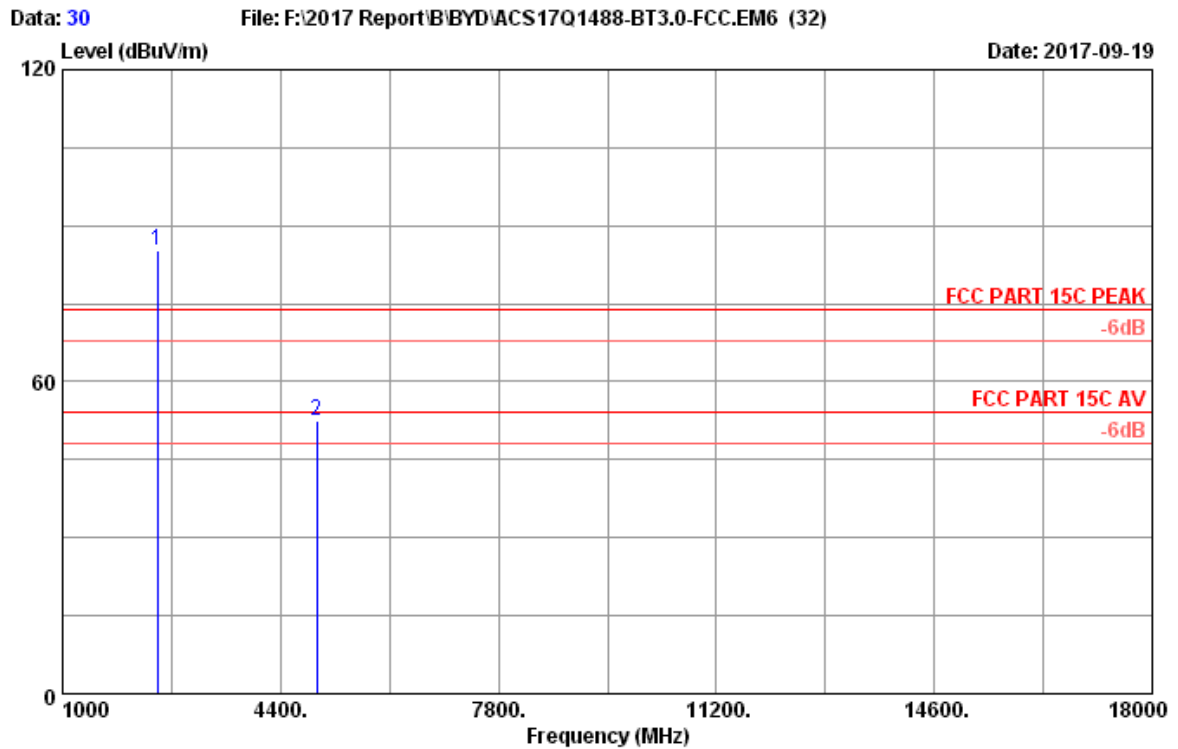

Site no. : 3m Chamber Data no. : 30
 Dis. / Ant. : 3m 2017 ANT 3006 HF Ant. pol. : VERTICAL
 Limit : FCC PART 15C PEAK
 Env. / Ins. : 23.1°C/52.8% Engineer : Lynn
 EUT : Notebook M/N:RZ09-0239
 Power rating : DC 20V From Adaptor Input AC 120V/60Hz
 Test Mode : 8-DPSK 2480 Tx Mode

No.	Freq. (MHz)	Ant. Factor (dB/m)	Cable Loss (dB)	Reading (dBuV)	Amp factor (dB)	Emission Level (dBuV/m)	Limits (dBuV/m)	Margin (dB)	Remark
1	2480.00	28.08	8.02	84.58	35.34	85.34	74.00	-11.34	Peak
2	4960.00	33.73	12.38	42.09	35.63	52.57	74.00	21.43	Peak

Remarks: 1. Emission Level= Antenna Factor + Cable Loss + Reading -Amp factor.
 2. The emission levels that are 20dB below the official limit are not reported.



Site no. : 3m Chamber Data no. : 32
 Dis. / Ant. : 3m 2017 ANT 3006 HF Ant. pol. : HORIZONTAL
 Limit : FCC PART 15C PEAK
 Env. / Ins. : 23.1°C/52.8% Engineer : Lynn
 EUT : Notebook M/N:RZ09-0239
 Power rating : DC 20V From Adaptor Input AC 120V/60Hz
 Test Mode : 8-DPSK 2480 Tx Mode

No.	Freq. (MHz)	Ant. Factor (dB/m)	Cable Loss (dB)	Reading (dBuV)	Amp factor (dB)	Emission Level (dBuV/m)	Limits (dBuV/m)	Margin (dB)	Remark
1	2480.00	28.08	8.02	88.52	35.34	89.28	74.00	-15.28	Peak
2	4960.00	33.73	12.38	42.51	35.63	52.99	74.00	21.01	Peak

Remarks: 1. Emission Level= Antenna Factor + Cable Loss + Reading -Amp factor.
 2. The emission levels that are 20dB below the official limit are not reported.

6. CONDUCTED SPURIOUS EMISSIONS

6.1.Limit

In any 100kHz bandwidth outside the frequency bands in which the spread spectrum intentional radiator is operating, the radio frequency power that is produced by the intentional radiator shall be at least 20dB below that in the 100kHz bandwidth within the band that contains the highest level of the desired power.

6.2.Test Procedure

The transmitter output was connected to a spectrum analyzer, The resolution bandwidth is set to 100 kHz, The video bandwidth is set to 300 kHz and measure all the emissions With peak detector.

6.3.Test result

PASS (The testing data was attached in the next pages.)

Hopping off

GFSK

2402MHz(30MHz – 1GHz)

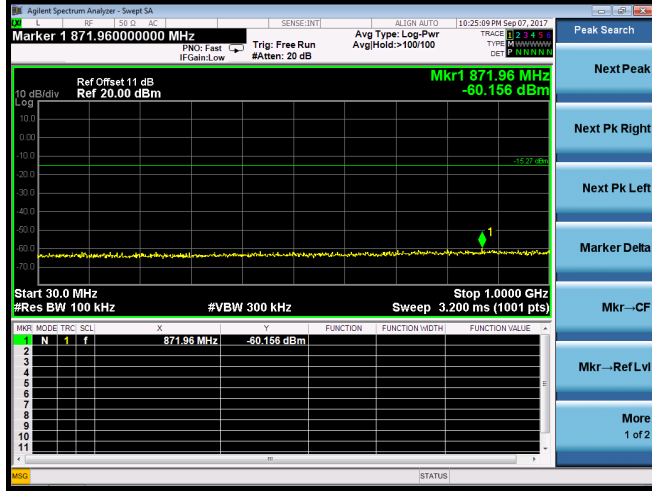

2402MHz(10GHz – 25GHz)

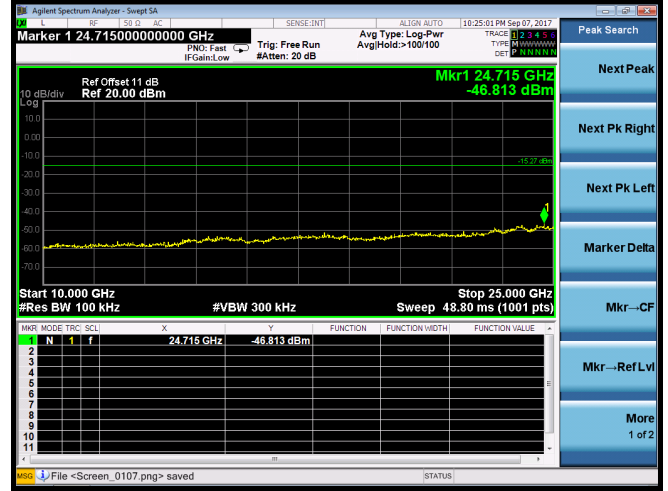

2402MHz(1GHz – 10GHz)

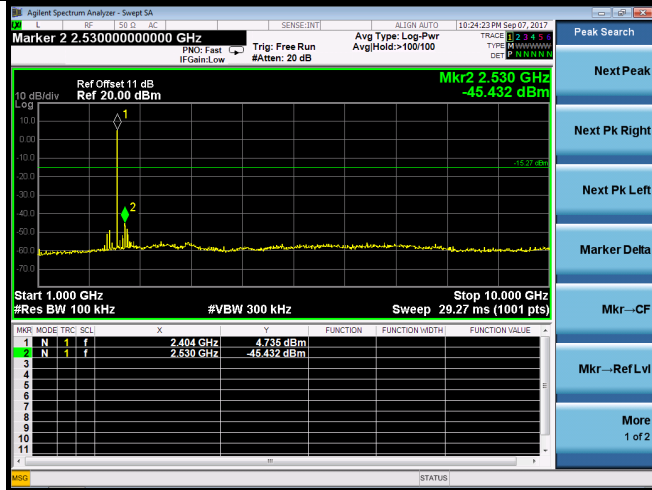

2441(30MHz – 1GHz)

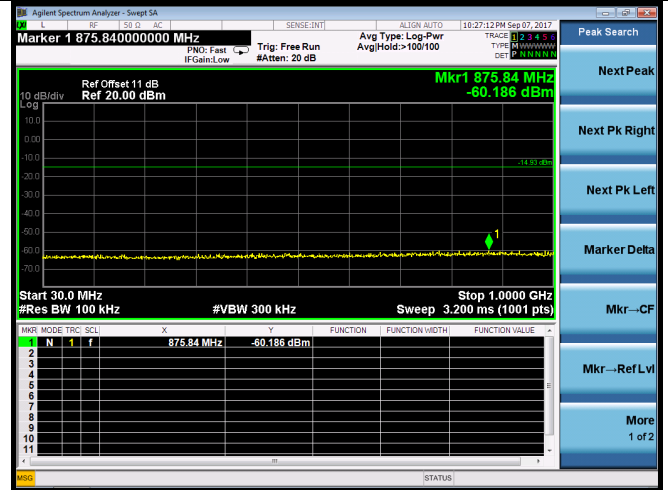

2402MHz(2.3GHz – 2.4GHz)

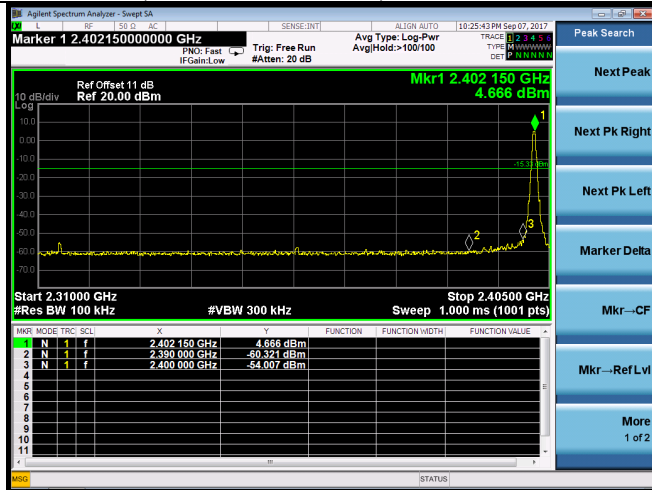

2441(1GHz – 10GHz)

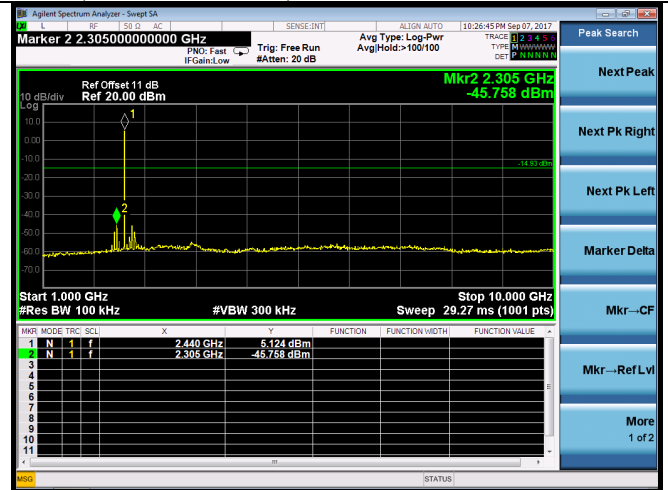

2441(10GHz – 25GHz)

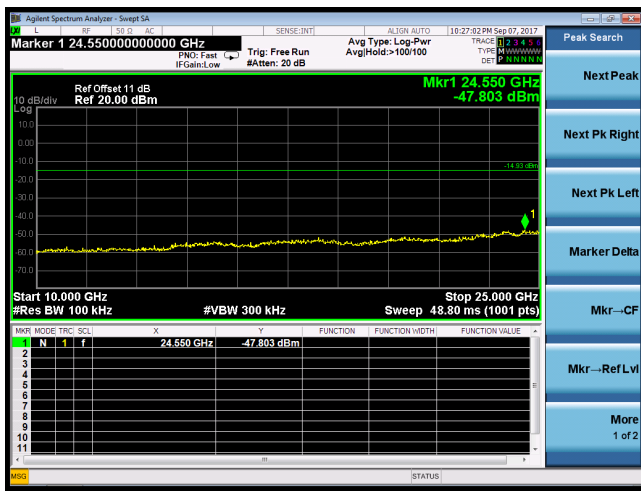

2480MHz(2.4GHz – 2.5GHz)

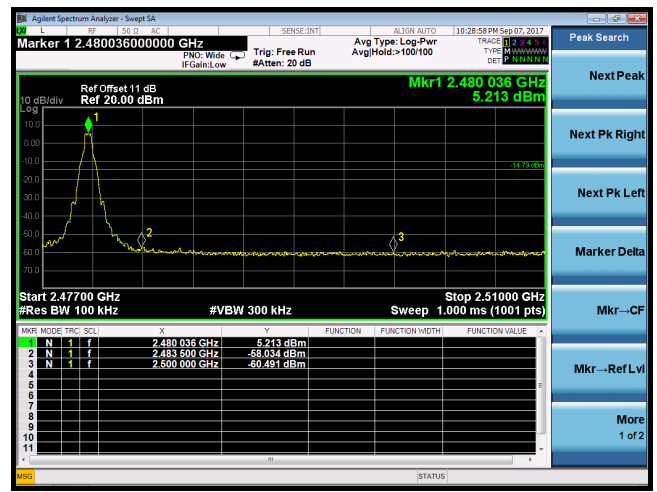

2480MHz(30MHz – 1GHz)

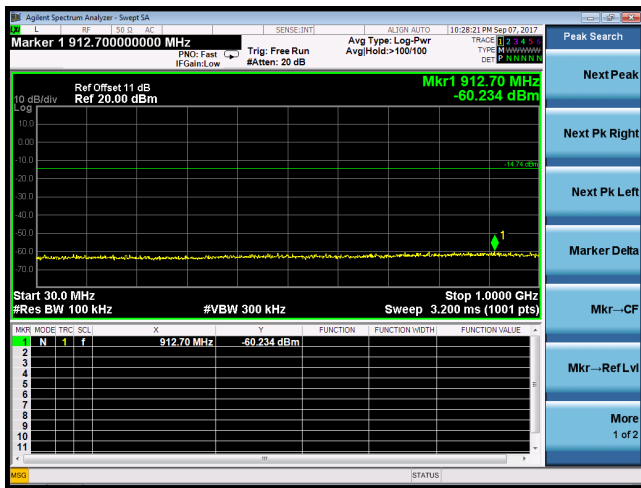

2480MHz(10GHz – 25GHz)

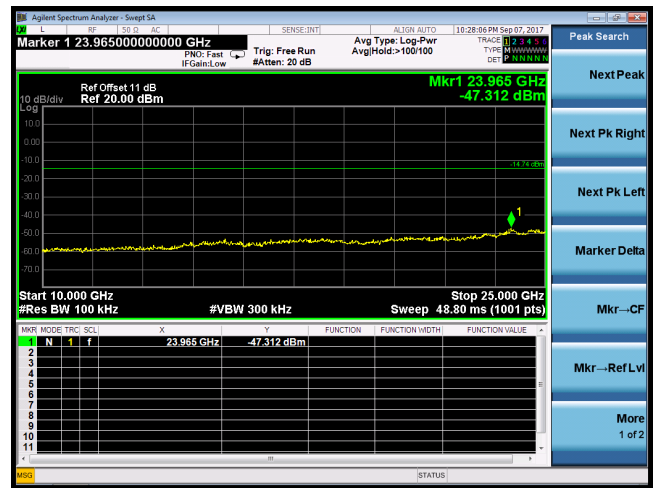

2480MHz(1GHz – 10GHz)

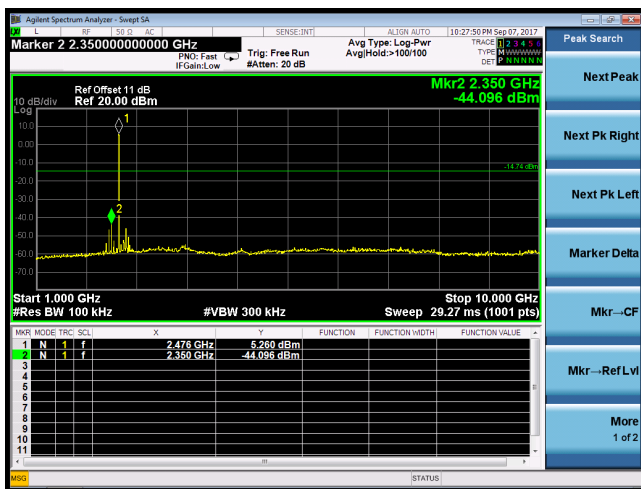

8-DPSK

2402MHz(30MHz – 1GHz)

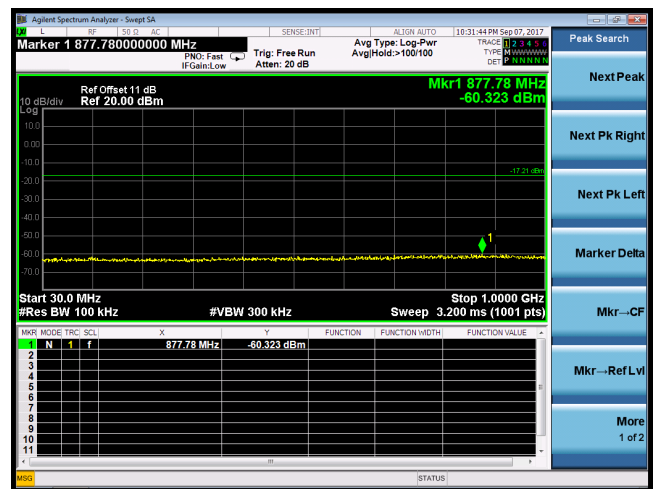

2402MHz(1GHz – 10GHz)

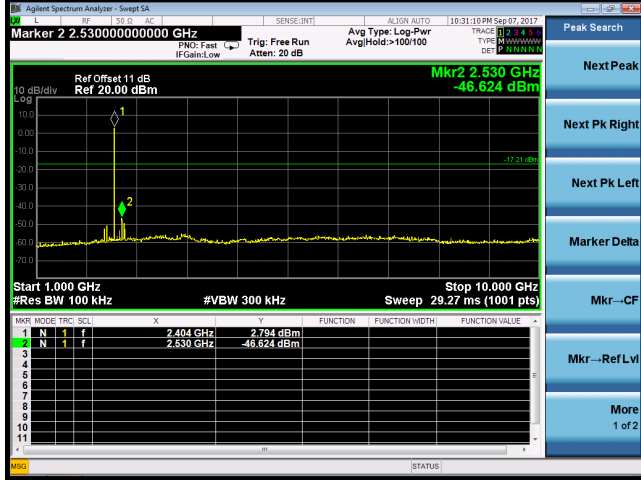

2441MHz (30MHz – 1GHz)

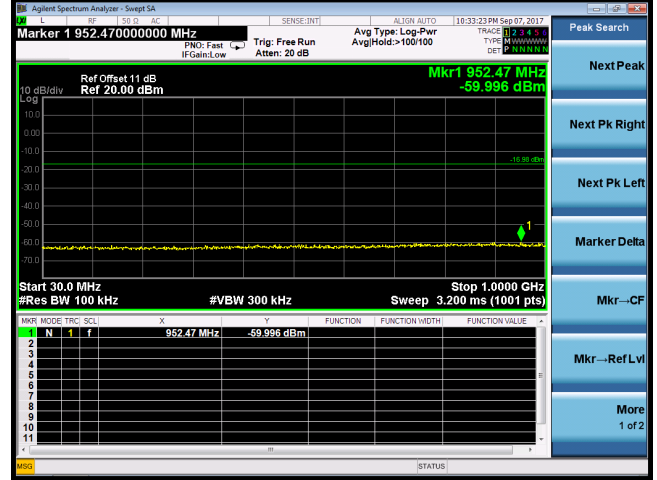

2402MHz(2.3GHz – 2.4GHz)

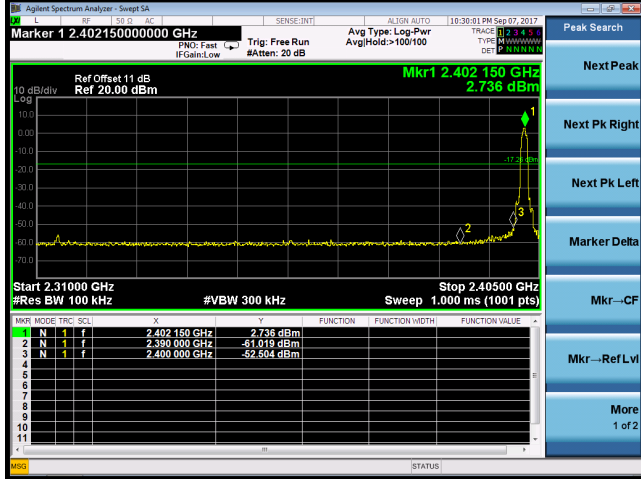

2441MHz(1GHz – 10GHz)

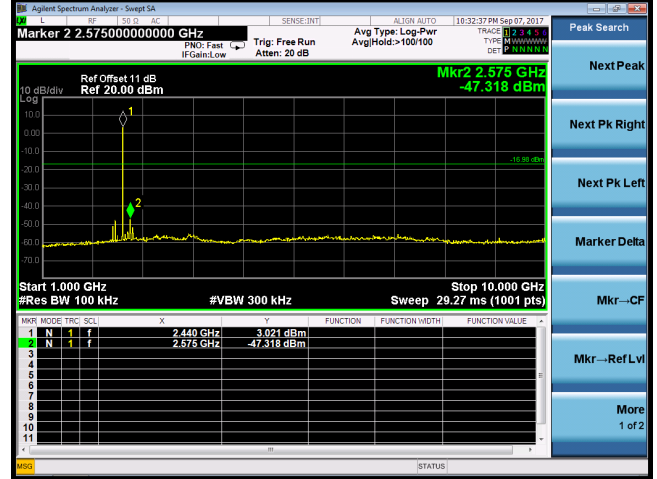

2402MHz(10GHz – 25GHz)

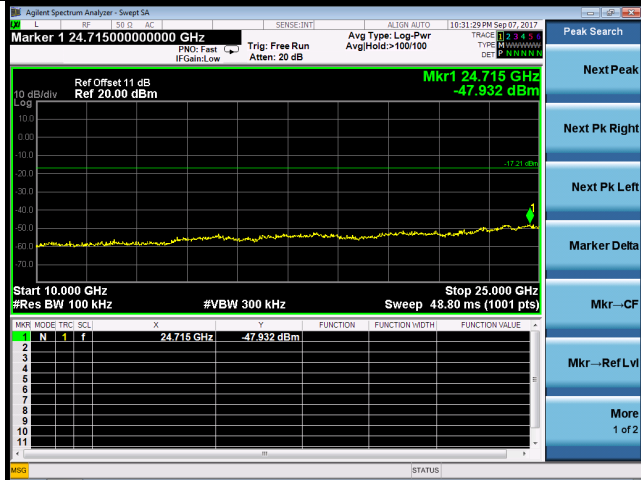

2441MHz(10GHz – 25GHz)

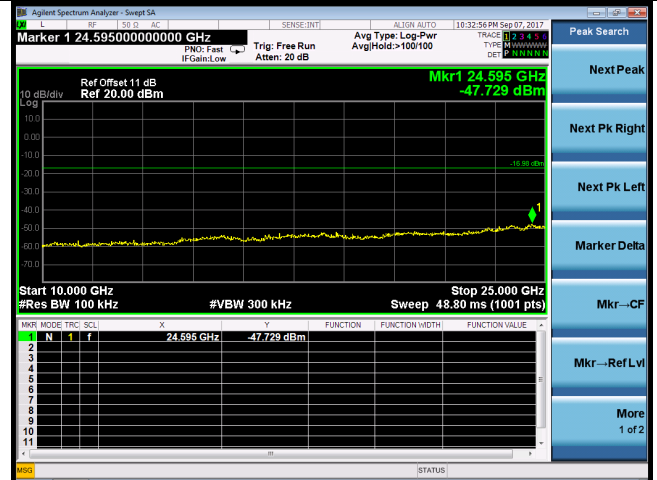

2480MHz(30MHz – 1GHz)

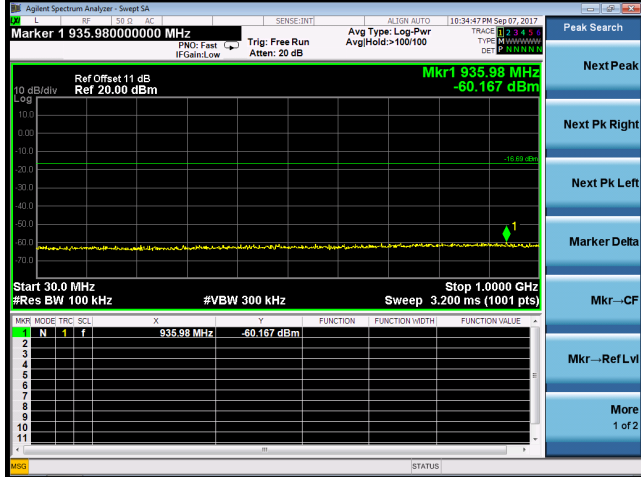

2480MHz(10GHz – 25GHz)

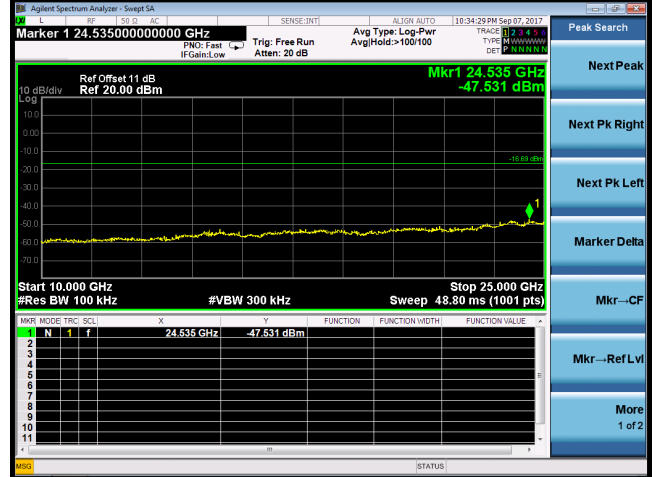

2480MHz(1GHz – 10GHz)

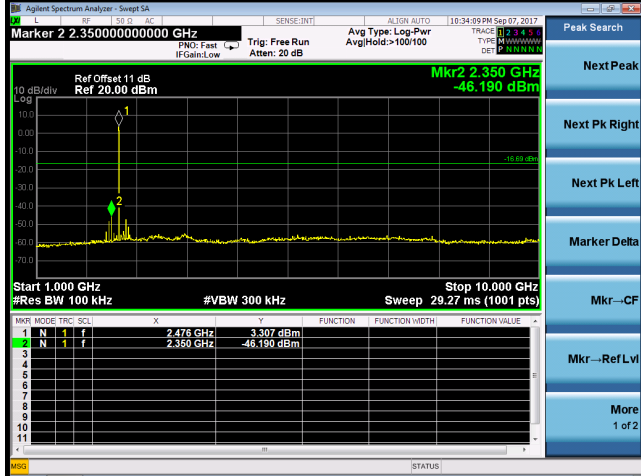

Hopping on GFSK(2.3GHz – 2.4GHz)

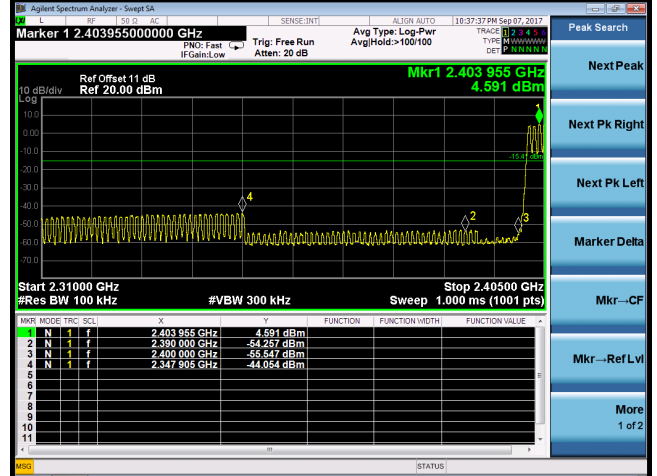

2480MHz(2.4GHz – 2.5GHz)

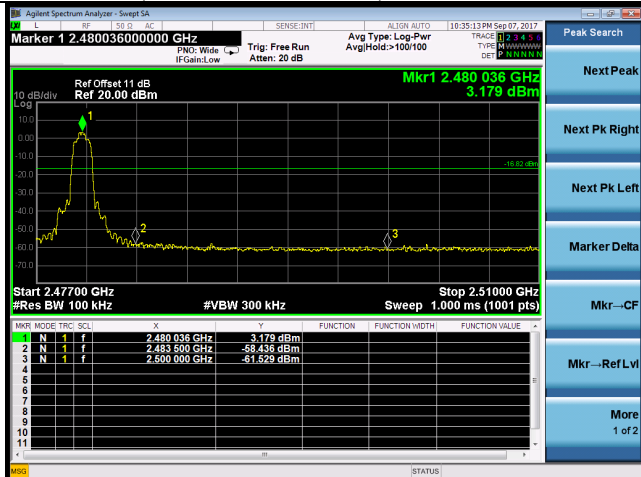

(2.4GHz – 2.5GHz)

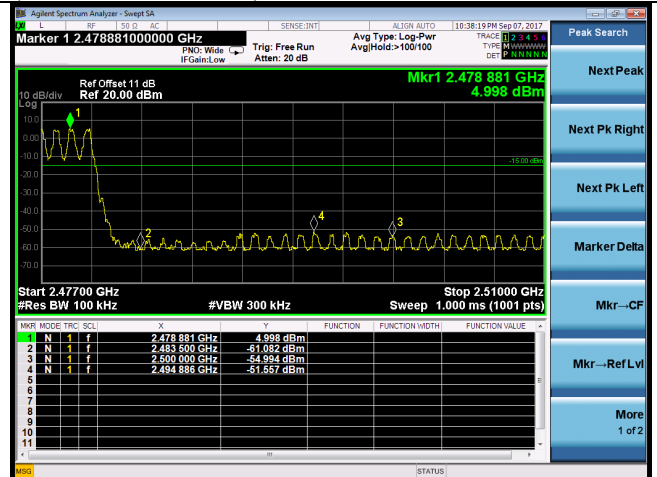

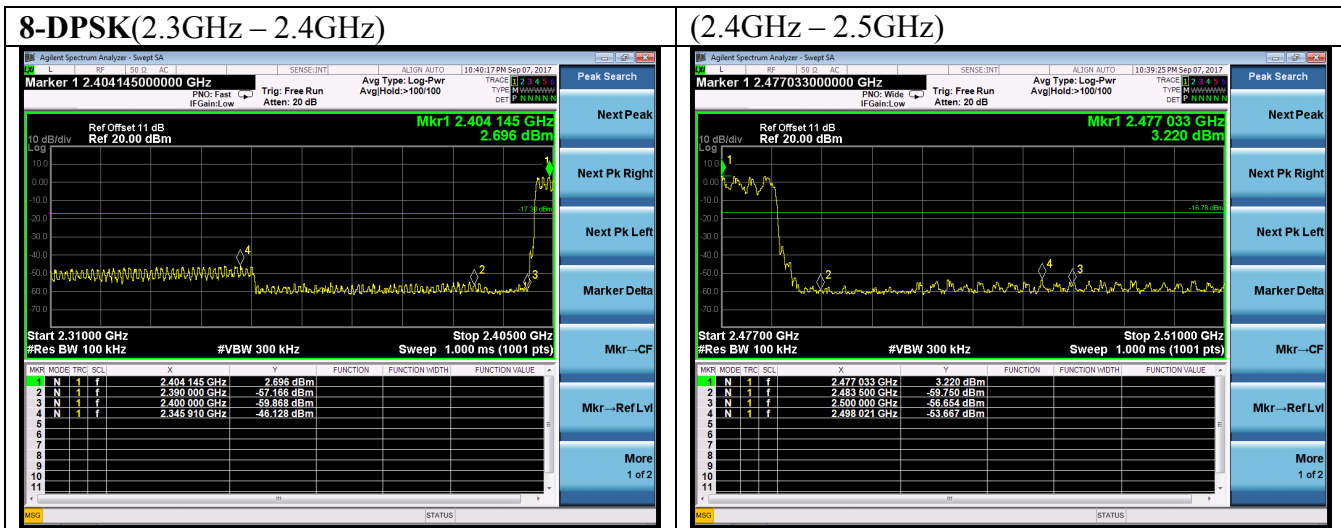

UL Verification Services (Guangzhou) Co., Ltd, Song Shan Lake Branch

This report shall not be reproduced except in full, without the written approval of UL Verification Services (Guangzhou) Co., Ltd, Song Shan Lake Branch

7. 20 dB & 99% BANDWIDTH TEST

7.1.Limit

Intentional radiators operating under the alternative provisions to the general emission limits, as contained in § 15.217 through 15.257 and in Subpart E of this part and RSS-GEN, must be designed to ensure that the 20 dB bandwidth of the emission, or whatever bandwidth may otherwise be specified in the specific rule section under which the equipment operates, is contained within the frequency band designated in the rule section under which the equipment is operated.

7.2.Test Procedure

1. Connect the antenna port of the EUT to the spectrum analyzer.
2. Let the EUT transmit at Low/ Mid/ High channel with test software.
3. Setting of SA is following as: RBW: 30kHz / VBW: 100kHz
 Sweep Mode: Continuous sweep
 Detect mode: Positive peak
 Trace mode: Max hold.
4. Use the occupied bandwidth function of the SA measure the 20dB bandwidth directly.

7.3.Test Results

EUT: Notebook		
M/N: RZ09-0239		
Test date: 2017-08-29	Pressure: 102.1±1.0 kpa	Humidity: 51.1±3.0%
Tested by: Kebo	Test site: RF site	Temperature:22.8±0.6 °C

Test Mode	Frequency (MHz)	20dB bandwidth (KHz)	Limit (KHz)
GFSK	2402	902.1	N/A
	2441	902.2	N/A
	2480	901.6	N/A
8-DPSK	2402	1242	N/A
	2441	1223	N/A
	2480	1237	N/A

Conclusion : PASS

Test Mode	Frequency (MHz)	99% Bandwidth (KHz)	Limit (KHz)
GFSK	2402	864.40	N/A
	2441	863.66	N/A
	2480	863.36	N/A
8-DPSK	2402	1152.1	N/A
	2441	1151.4	N/A
	2480	1151.6	N/A
Conclusion : PASS			

GFSK

2402MHz



8-DPSK

2402MHz

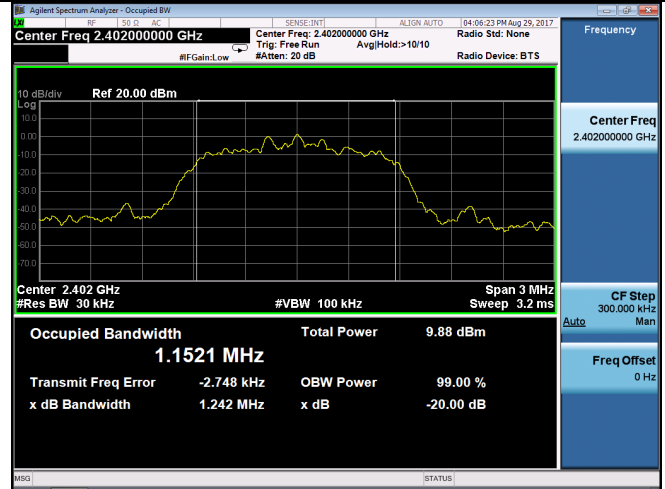

2441MHz

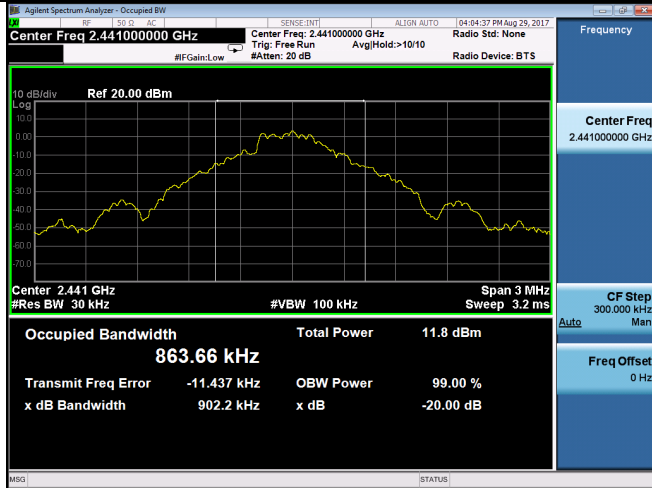

2441MHz

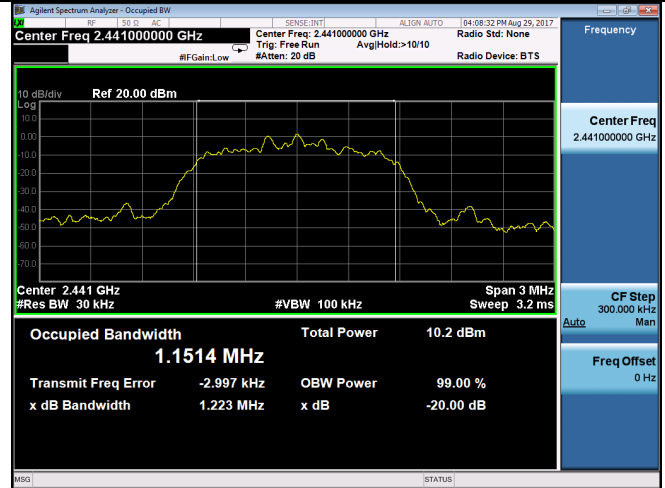

2480MHz



2480MHz

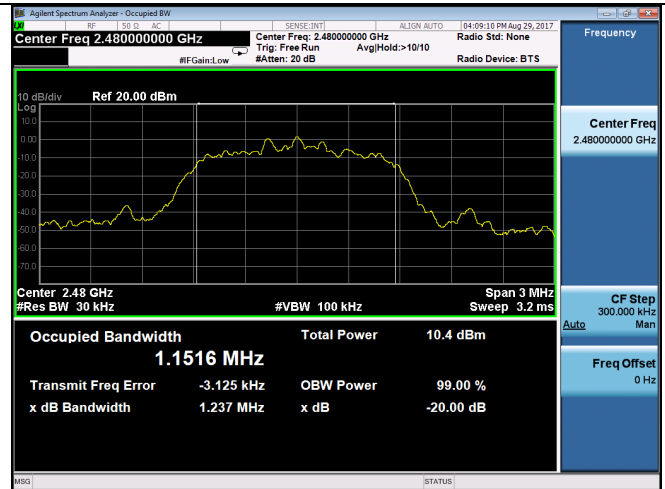

8. CARRIER FREQUENCY SEPARATION TEST

8.1.Limit

Frequency hopping systems shall have hopping channel carrier frequency separated by a minimum of 25kHz or the 20dB bandwidth of the hopping channel, whichever is greater. Alternatively, frequency hopping systems operating in the 2400-2483.5 MHz band may have hopping channel carrier frequencies that are separated by 25 kHz or two-thirds of the 20 dB bandwidth of the hopping channel, whichever is greater, provided the systems operate with an output power no greater than 125 mW.

8.2.Test Procedure

1. Connect the antenna port of the EUT to the Spectrum analyzer.
2. Let the EUT transmit at Low/ Mid/ High channel.
3. Setting of SA is following as: RBW: 100kHz / VBW: 300kHz.Span:5MHz
4. Use the mark Delta function of the SA measure out the channel separation.

8.3. Test Results.

EUT: Notebook		
M/N: RZ09-0239		
Test date: 2017-09-07	Pressure: 101.4±1.0kpa	Humidity: 51.4±3.0%
Tested by: Kebo	Test site: RF Site	Temperature: 23.4±0.6°C

Test Mode	Channel separation	Limit(KHz)	Conclusion
GFSK	1.0MHz	601.467	PASS
8-DPSK	1.0MHz	828.000	PASS

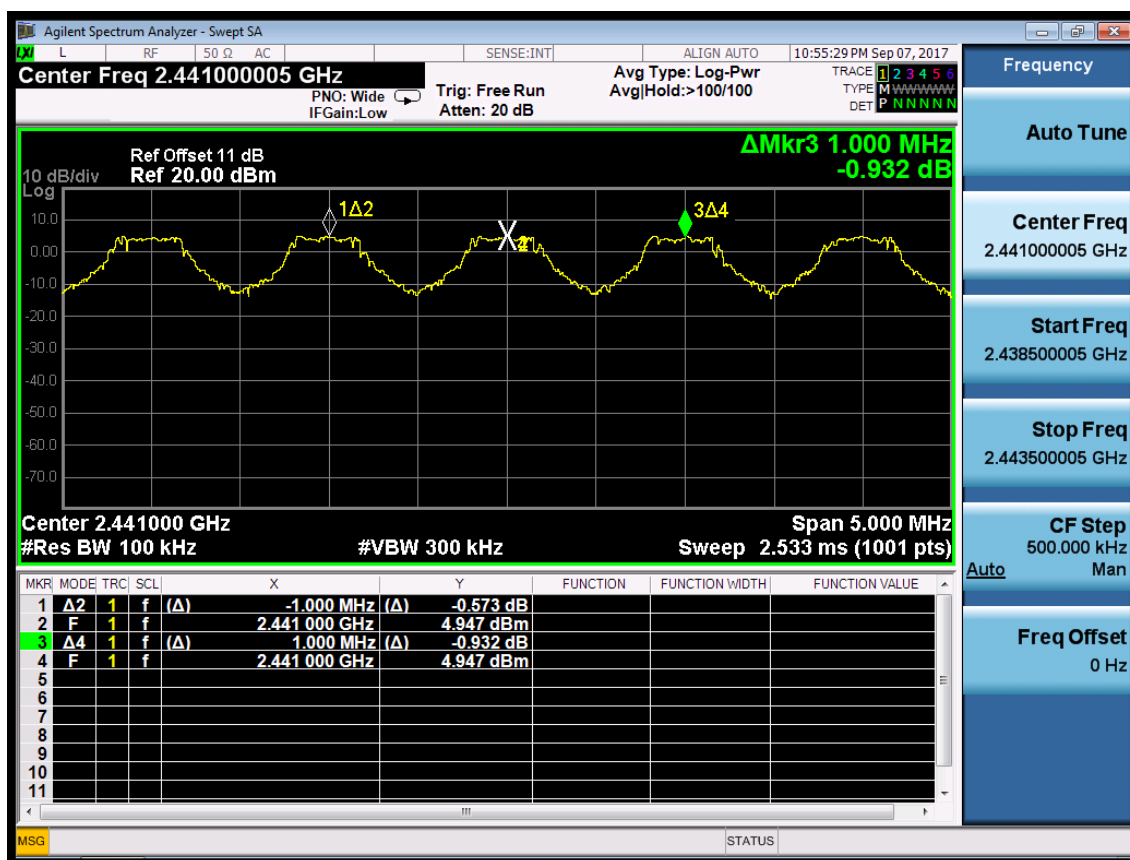

9. NUMBER OF HOPPING FREQUENCY TEST

9.1.Limit

Frequency hopping systems in the 2400-2483.5 MHz band shall use at least 15 channels

9.2.Test Procedure

1. Connect the antenna of the EUT to Spectrum analyzer and let the EUT working at hopping mode.
2. Setting of SA is following as: RBW: 100kHz / VBW: 300kHz
 Start frequency: 2390MHz
 Stop frequency: 2483.5MHz
 And waiting for the hopping trace until stability, count out the number of the hopping.

9.3.Test Results

EUT: Notebook		
M/N: RZ09-0239		
Test date: 2017-09-09	Pressure: 101.4±1.0 kpa	Humidity: 51.4±3.0%
Tested by: Kebo	Test site: RF Site	Temperature: 23.4±0.6°C

Test Mode	Number of channel	Limit	Conclusion
GFSK	79	>=15	PASS
8-DPSK	79	>=15	PASS

GFSK

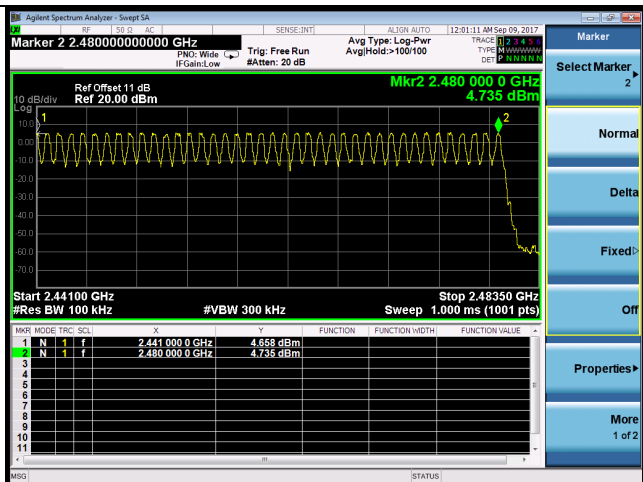
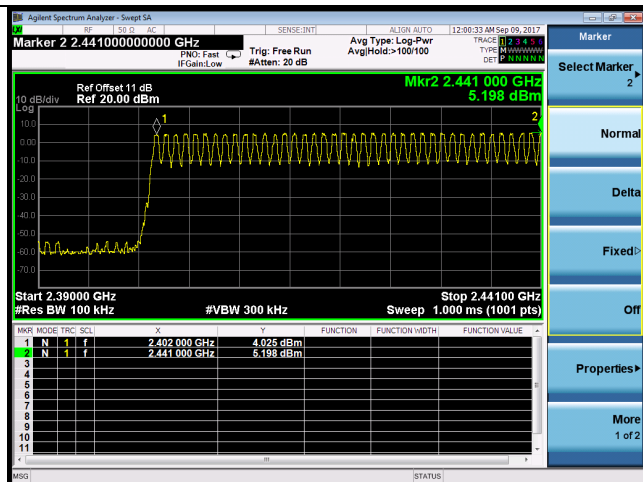

8-DPSK

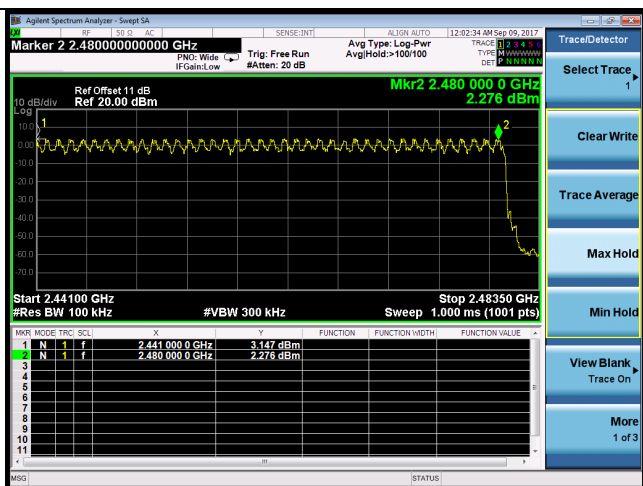
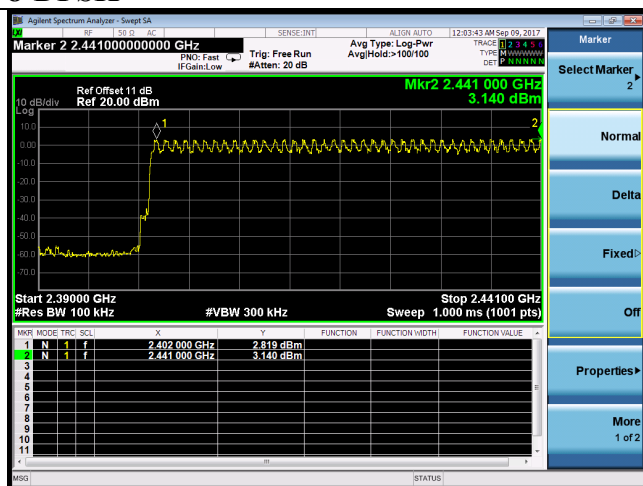

10.DWELL TIME

10.1.Limit

The average time of occupancy on any channel shall not be greater than 0.4 seconds within a period of 0.4 seconds multiplied by the number of hopping channels employed.

10.2.Test Procedure

1. Connect the antenna of the EUT to Spectrum analyzer and let the EUT working at hopping mode.
2. Setting of SA is following as:
 RBW: 100kHz / VBW: 100kHz
 Sweep Mode: Single
 Detect mode: Positive peak
 Trace mode: Auto
 Span: 0Hz
 Sweep time: 5s and big enough to measure one hopping signal
3. Use below formula calculate the Dwell time
 Dwell time=Hopping number per second*0.4*channel number*Pulse bandwidth per hopping.

10.3.Test Results

EUT: Notebook		
M/N: RZ09-0239		
Test date: 2017-09-07	Pressure: 101.4±1.0kpa	Humidity: 51.4±3.0%
Tested by: Kebo	Test site: RF Site	Temperature: 23.4±0.6°C

Mode		dwell time	Limit	Conclusion
GFSK	DH1	48 hops/5s*0.4*79channels* 0.419 ms =127.108ms	≅ 400ms	PASS
	DH3	24 hops/5s*0.4*79channels* 1.677 ms =254.367ms	≅ 400ms	PASS
	DH5	21 hops/5s*0.4*79channels* 2.940 ms =390.197ms	≅ 400ms	PASS
8-DPSK	3-DH1	48 hops/5s*0.4*79channels* 0.429 ms =130.141ms	≅ 400ms	PASS
	3-DH3	26 hops/5s*0.4*79channels* 1.692 ms =278.029ms	≅ 400ms	PASS
	3-DH5	12 hops/5s*0.4*79channels* 2.950 ms =223.728ms	≅ 400ms	PASS

Note: All the lower levels were signaled from receiver and should not be considered in here.

GFSK

DH 1

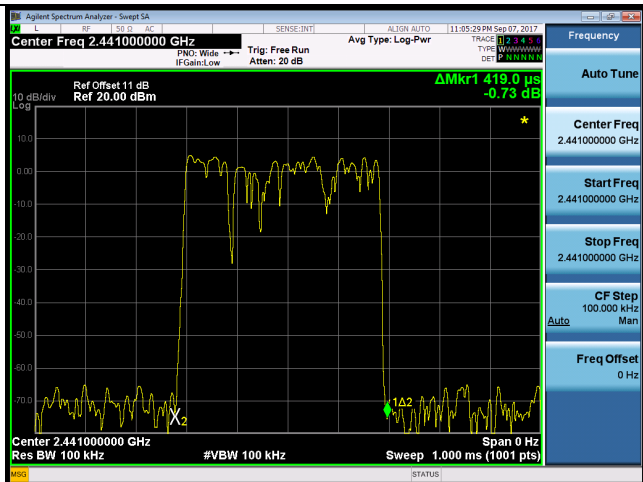
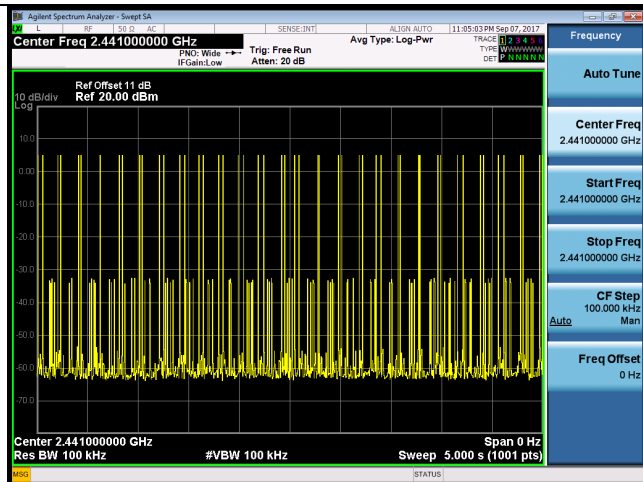

DH 3

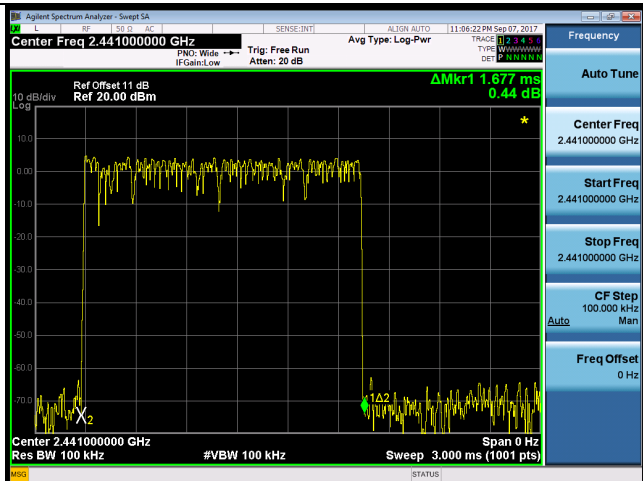
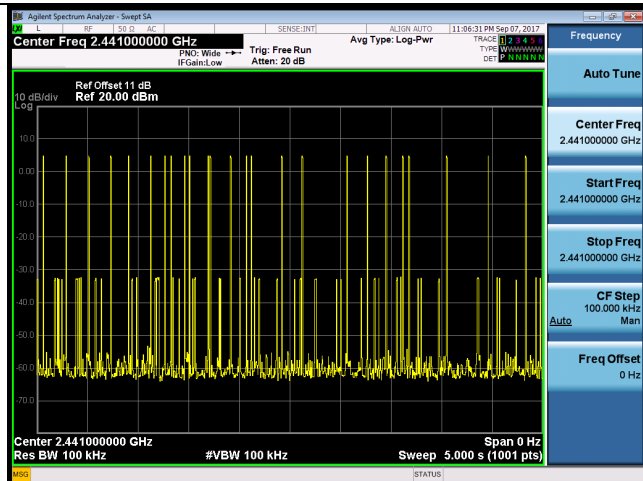

DH 5

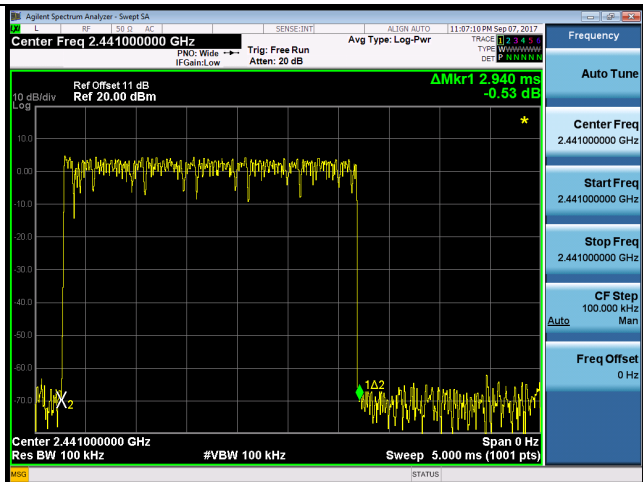
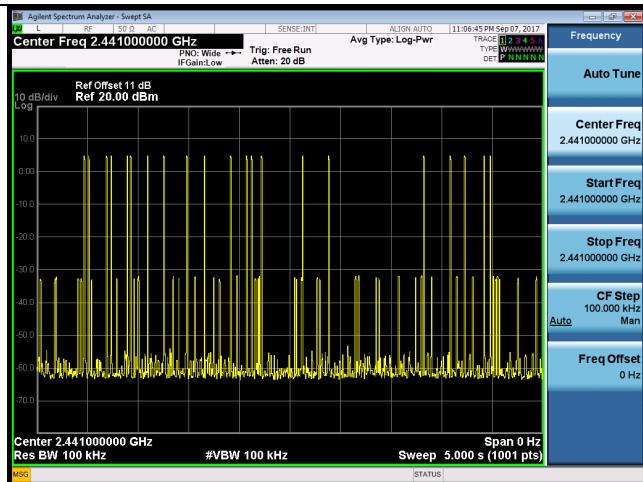

8-DPSK

3DH 1

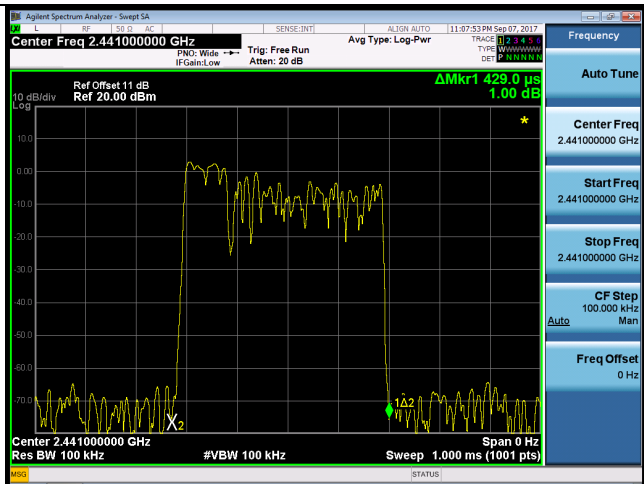
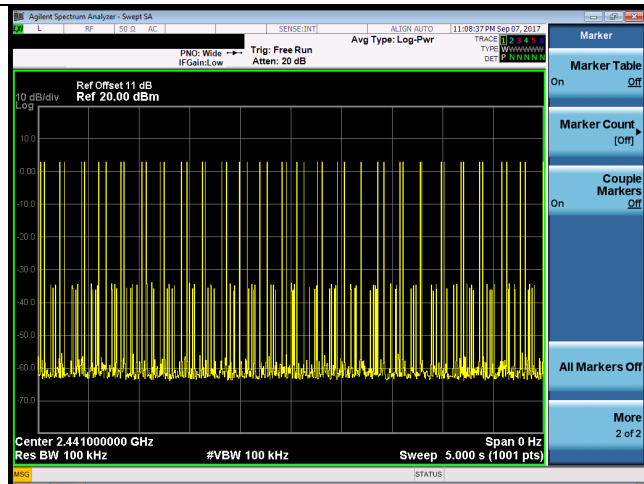

3DH 3

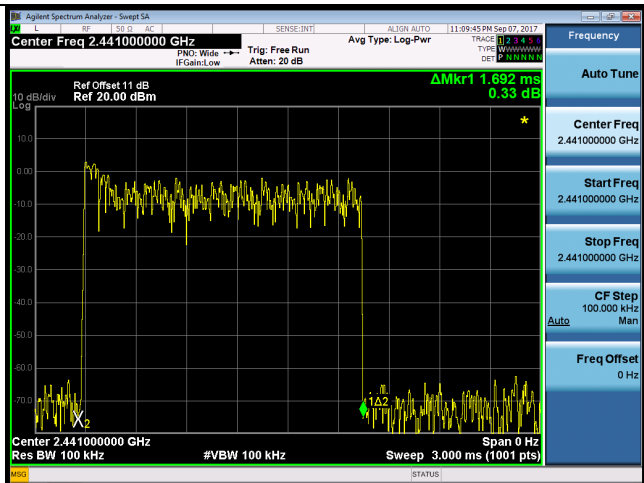
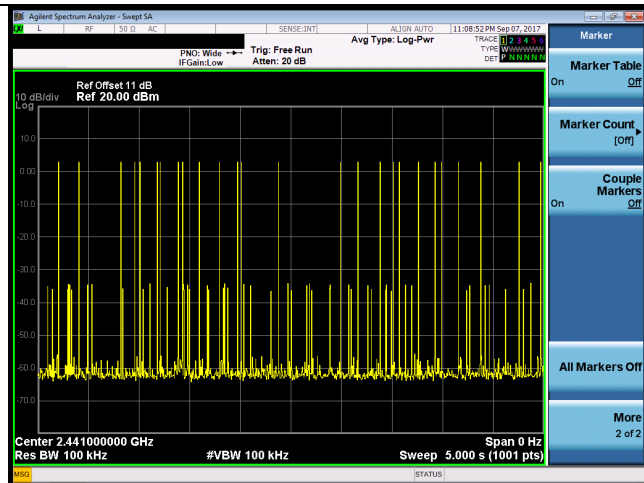

3DH 5

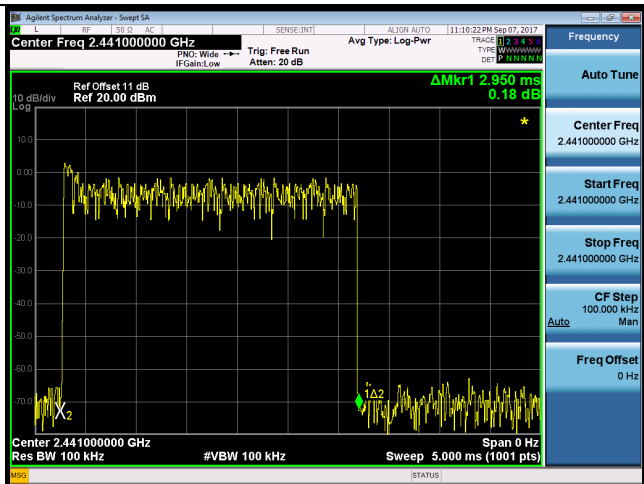
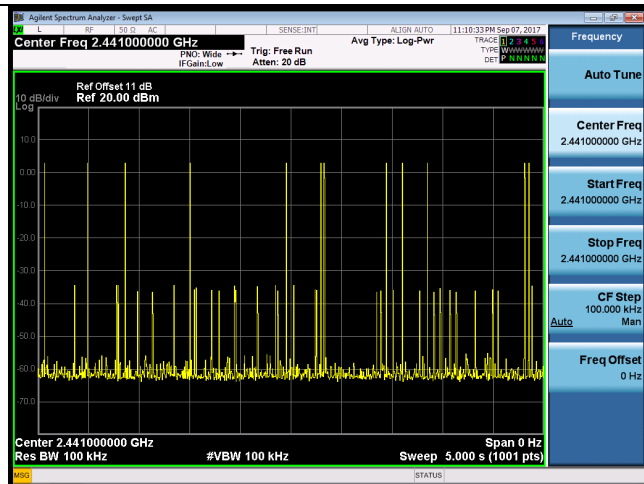

11. MAXIMUM PEAK OUTPUT POWER TEST

11.1. Limit for Peak output Power

For frequency hopping systems operating in the 2400-2483.5 MHz band employing at least 75 non-overlapping hopping channels, and all frequency hopping systems in the 5725-5850 MHz band: 1 watt. For all other frequency hopping systems in the 2400-2483.5 MHz band: 0.125 watts. The max. peak conducted output power should not exceed 1.0W and the E.I.R.P shall not exceed 4W.

11.2. Test Procedure for Peak output Power

Connected the EUT's antenna port to Power Sensor, and use power meter to test peak output power directly. Then add the antenna Gain get the EIRP test result.

11.3. Test Procedure for e.i.r.p

(1) Connected the EUT's antenna port to the Spectrum Analyzer by suitable attenuator , set the Spectrum Analyzer as below:

Span: Zero

RBW: 100kHz

VBW: 100kHz

Read out the duty cycle(X) of the transmitter and record as X

(2) Use a power meter measure the average power of the EUT.

(3) Calculated e.i.r.p according to the formula: $\text{Read} + \text{Cable loss} + \text{Atten loss} + \text{Antenna Gain} + 10\log(1/x)$

(4) Repeated test at the lowest, the middle, and the highest frequency of the stated frequency range.

11.4. Test Results

EUT: Notebook			
M/N: RZ09-0239			
Test date: 2017-09-01		Pressure: 102.5±1.0 kpa	Humidity: 52.3±3.0%
Tested by: Kebo		Test site: RF site	Temperature: 22.1±0.6 °C
Test Mode	Frequency (MHz)	Peak output Power (dBm)	Limit (dBm)
GFSK	2402	2.10	21
	2441	2.14	21
	2480	2.09	21
8-DPSK	2402	2.71	21
	2441	2.34	21
	2480	2.42	21
Conclusion: PASS			

Test Mode	Frequency (MHz)	EIRP (dBm)	Limit (dBm)
GFSK	2402	3.99	36
	2441	4.03	36
	2480	3.98	36
8-DPSK	2402	4.60	36
	2441	4.23	36
	2480	4.31	36
Conclusion: PASS			

12. BAND EDGE COMPLIANCE TEST

12.1. Limit

All the lower and upper band-edges emissions appearing within 2310MHz to 2390MHz and 2483.5MHz to 2500MHz restricted frequency bands shall not exceed the limits shown in 15.209 and RSS-247, all the other emissions outside operation frequency band 2400MHz to 2483.5MHz shall be at least 20dB below the fundamental emissions, or comply with 15.209 and RSS-210 limits.

12.2. Test Procedure

For upper band emissions that are up to two bandwidths(2MHz) away (2483.5MHz to 2485.5MHz) from the band-edge use below produce:

1. Choose a spectrum analyzer span that encompasses both the peak of the fundamental emission and the band-edge emission under investigation. Set the analyzer RBW to 100KHz and with a video bandwidth 300KHz. Record the peak levels of the fundamental emission and the relevant band-edge emission, Observe the stored trace and measure the amplitude delta between the peak of the fundamental and the peak of the band-edge emission. This is not a field strength measurement, it is only a relative measurement to determine the amount by which the emission drops at the band edge relative to the highest fundamental emission level.
2. Subtract the delta measured in step (1) from the maximum field strengths measured in clause 4 .The resultant field strengths are then used to determine band-edge compliance as required by Section 15.205 and RSS-247.

For emissions above two bandwidths away from the band-edge use below produce:

1. The EUT is placed on a insulating material (up to 12mm thick) worked at highest radiated power.
2. The turntable was rotated for 360 degrees to determine the position of maximum emission level.
3. EUT is set 3m away from the receiving antenna, which is varied from 1m to 4m to find out the highest emission.
4. Set the spectrum analyzer in the following setting in order to capture the lower and upperband-edges of the emission:
 - (a) PEAK: RBW=1MHz ;VBW=3MHz, PK detector, Sweep=AUTO
 - (b) This is pulse Modulation device a duty cycle factor was used to calculate average level based measured peak level.

12.3. Test Results

Pass (The testing data was attached in the next pages.)

Note: If the PK measured levels comply with average limit, then the average level were deemed to comply with average limit.

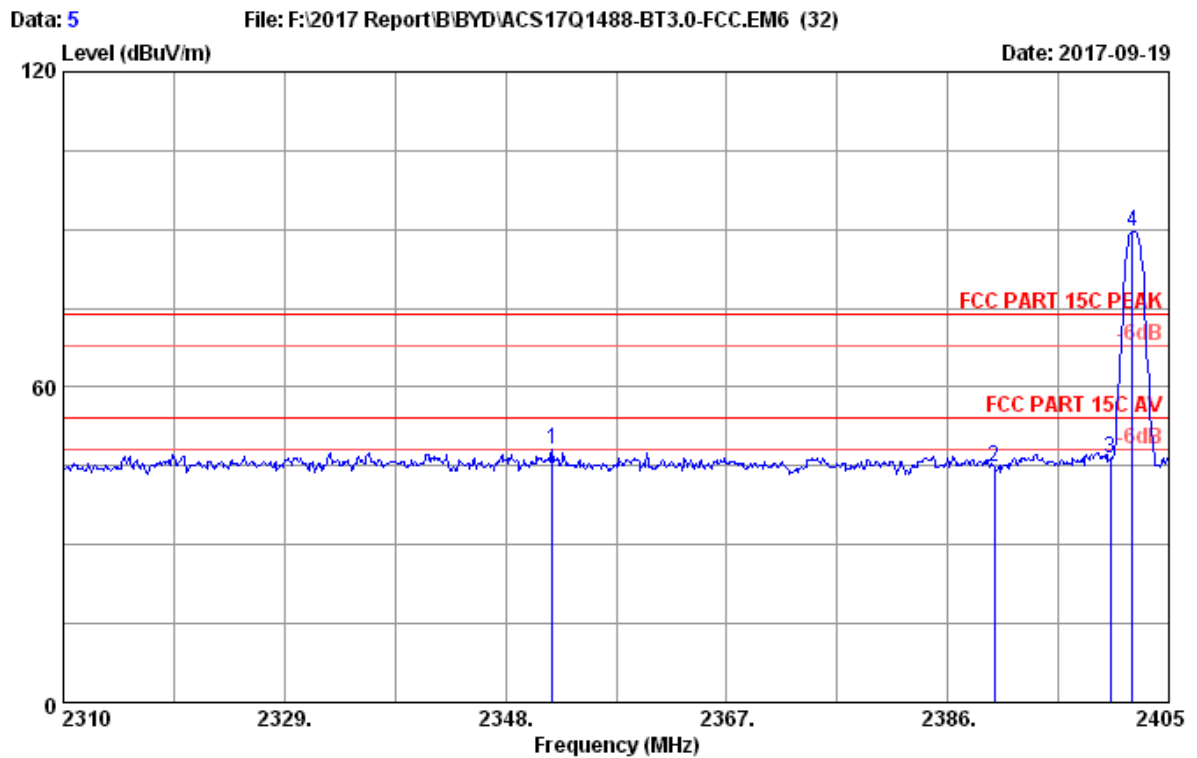

Site no. : 3m Chamber Data no. : 5
 Dis. / Ant. : 3m 2017 ANT 3006 HF Ant. pol. : HORIZONTAL
 Limit : FCC PART 15C PEAK
 Env. / Ins. : 23.1°C/52.8% Engineer : Lynn
 EUT : Notebook M/N:RZ09-0239
 Power rating : DC 20V From Adaptor Input AC 120V/60Hz
 Test Mode : GFSK 2402 Tx Mode

No.	Freq. (MHz)	Ant. Factor (dB/m)	Cable Loss (dB)	Reading (dBuV)	Amp factor (dB)	Emission Level (dBuV/m)	Limits (dBuV/m)	Margin (dB)	Remark
1	2351.99	27.91	7.81	47.59	35.32	47.99	74.00	26.01	Peak
2	2390.00	27.96	7.84	44.47	35.33	44.94	74.00	29.06	Peak
3	2400.00	27.96	7.88	45.84	35.33	46.35	74.00	27.65	Peak
4	2401.87	27.96	7.88	89.13	35.33	89.64	74.00	-15.64	Peak

Remarks: 1. Emission Level= Antenna Factor + Cable Loss + Reading -Amp factor.
 2. The emission levels that are 20dB below the official limit are not reported.

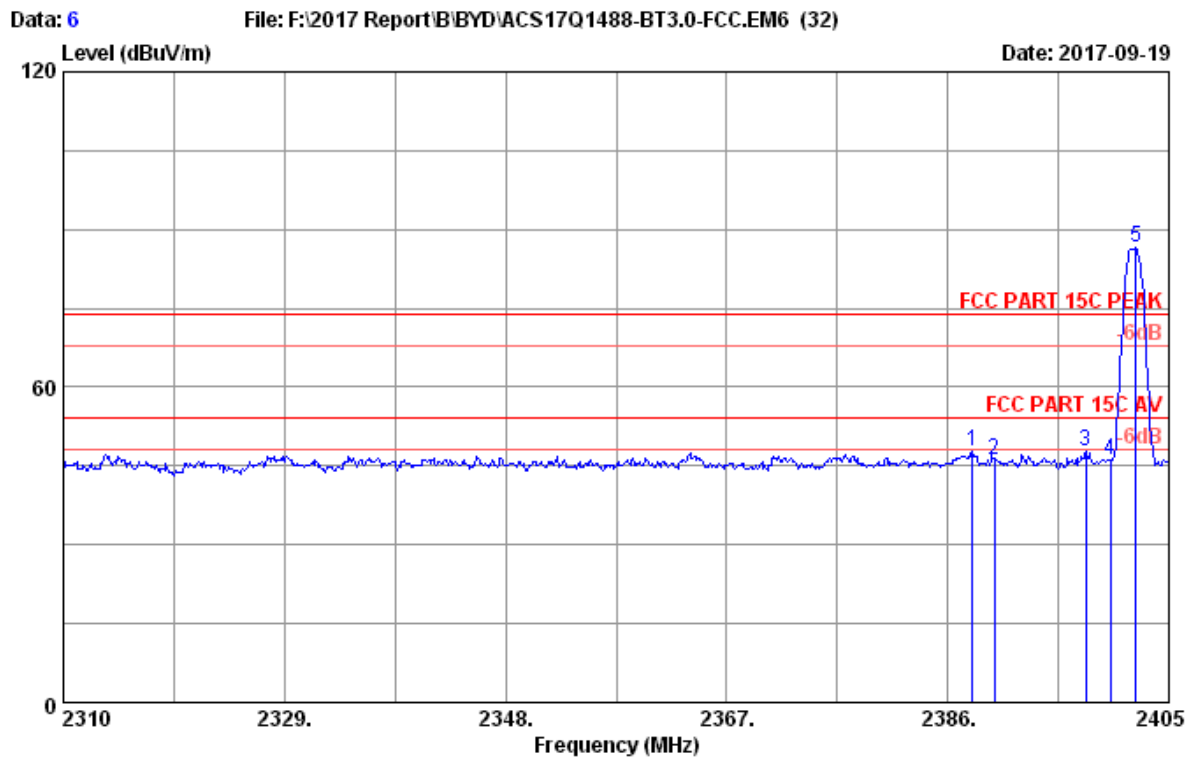

Site no. : 3m Chamber Data no. : 6
 Dis. / Ant. : 3m 2017 ANT 3006 HF Ant. pol. : VERTICAL
 Limit : FCC PART 15C PEAK
 Env. / Ins. : 23.1°C/52.8% Engineer : Lynn
 EUT : Notebook M/N:RZ09-0239
 Power rating : DC 20V From Adaptor Input AC 120V/60Hz
 Test Mode : GFSK 2402 Tx Mode

No.	Freq. (MHz)	Ant. Factor (dB/m)	Cable Loss (dB)	Reading (dBuV)	Amp factor (dB)	Emission Level (dBuV/m)	Limits (dBuV/m)	Margin (dB)	Remark
1	2388.09	27.96	7.84	47.36	35.33	47.83	74.00	26.17	Peak
2	2390.00	27.96	7.84	45.56	35.33	46.03	74.00	27.97	Peak
3	2397.88	27.96	7.88	47.16	35.33	47.67	74.00	26.33	Peak
4	2400.00	27.96	7.88	45.62	35.33	46.13	74.00	27.87	Peak
5	2402.15	27.96	7.88	85.95	35.33	86.46	74.00	-12.46	Peak

Remarks: 1. Emission Level= Antenna Factor + Cable Loss + Reading -Amp factor.
 2. The emission levels that are 20dB below the official limit are not reported.

Data: 15

File: F:\2017 Report\B\BYD\ACS17Q1488-BT3.0-FCC.EM6 (32)

Date: 2017-09-19

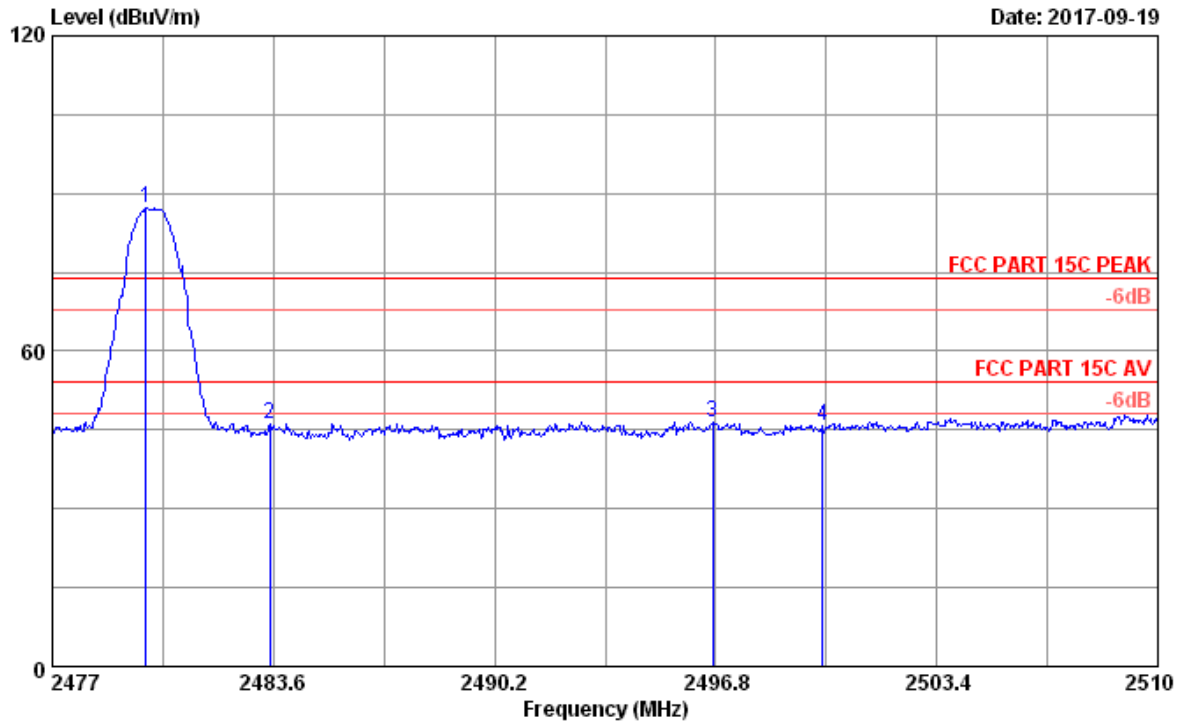

Site no. : 3m Chamber Data no. : 15
 Dis. / Ant. : 3m 2017 ANT 3006 HF Ant. pol. : VERTICAL
 Limit : FCC PART 15C PEAK
 Env. / Ins. : 23.1°C/52.8% Engineer : Lynn
 EUT : Notebook M/N:RZ09-0239
 Power rating : DC 20V From Adaptor Input AC 120V/60Hz
 Test Mode : GFSK 2480 Tx Mode

No.	Freq. (MHz)	Ant. Factor (dB/m)	Cable Loss (dB)	Reading (dBuV)	Amp factor (dB)	Emission Level (dBuV/m)	Limits (dBuV/m)	Margin (dB)	Remark
1	2479.81	28.08	8.02	86.42	35.34	87.18	74.00	-13.18	Peak
2	2483.50	28.08	8.02	45.40	35.34	46.16	74.00	27.84	Peak
3	2496.70	28.10	8.05	45.76	35.34	46.57	74.00	27.43	Peak
4	2500.00	28.10	8.05	45.14	35.34	45.95	74.00	28.05	Peak

Remarks: 1. Emission Level= Antenna Factor + Cable Loss + Reading - Amp factor.
 2. The emission levels that are 20dB below the official limit are not reported.

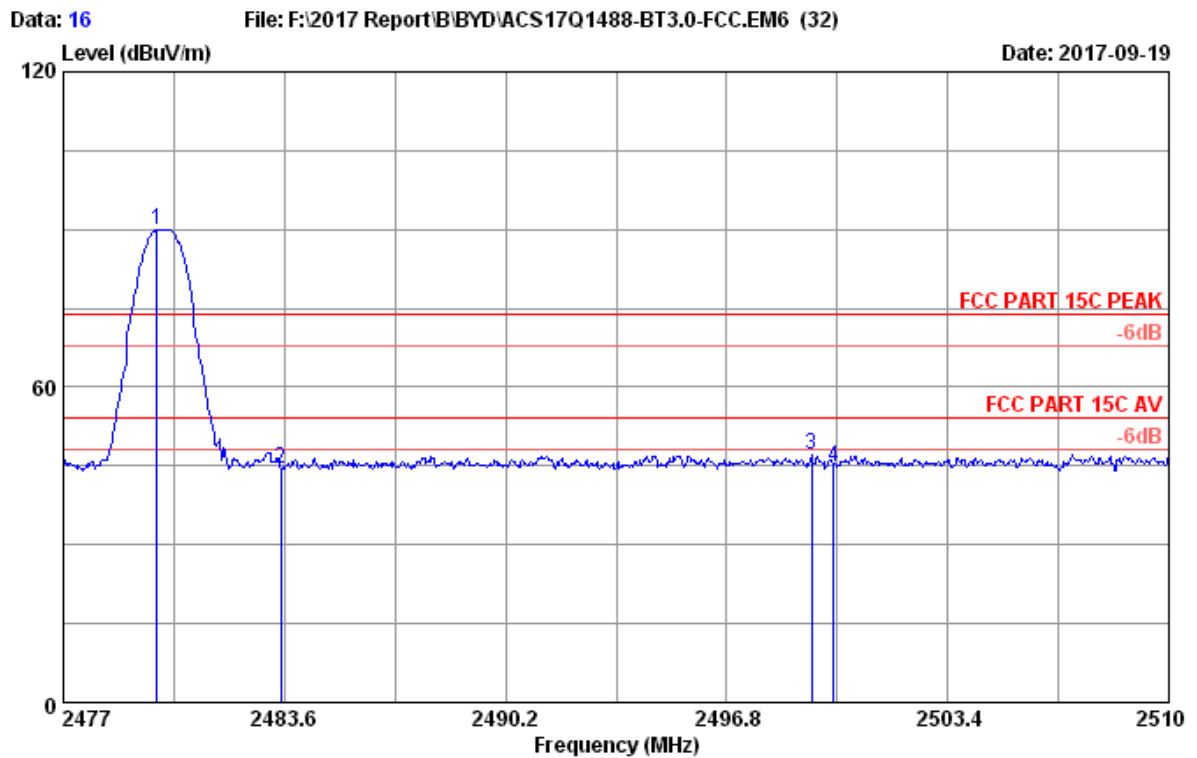

Site no. : 3m Chamber Data no. : 16
 Dis. / Ant. : 3m 2017 ANT 3006 HF Ant. pol. : HORIZONTAL
 Limit : FCC PART 15C PEAK
 Env. / Ins. : 23.1°C/52.8% Engineer : Lynn
 EUT : Notebook M/N:RZ09-0239
 Power rating : DC 20V From Adaptor Input AC 120V/60Hz
 Test Mode : GFSK 2480 Tx Mode

No.	Freq. (MHz)	Ant. Factor (dB/m)	Cable Loss (dB)	Reading (dBuV)	Amp factor (dB)	Emission Level (dBuV/m)	Limits (dBuV/m)	Margin (dB)	Remark
1	2479.81	28.08	8.02	89.18	35.34	89.94	74.00	-15.94	Peak
2	2483.50	28.08	8.02	43.84	35.34	44.60	74.00	29.40	Peak
3	2499.34	28.10	8.05	46.20	35.34	47.01	74.00	26.99	Peak
4	2500.00	28.10	8.05	44.04	35.34	44.85	74.00	29.15	Peak

Remarks: 1. Emission Level= Antenna Factor + Cable Loss + Reading - Amp factor.
 2. The emission levels that are 20dB below the official limit are not reported.

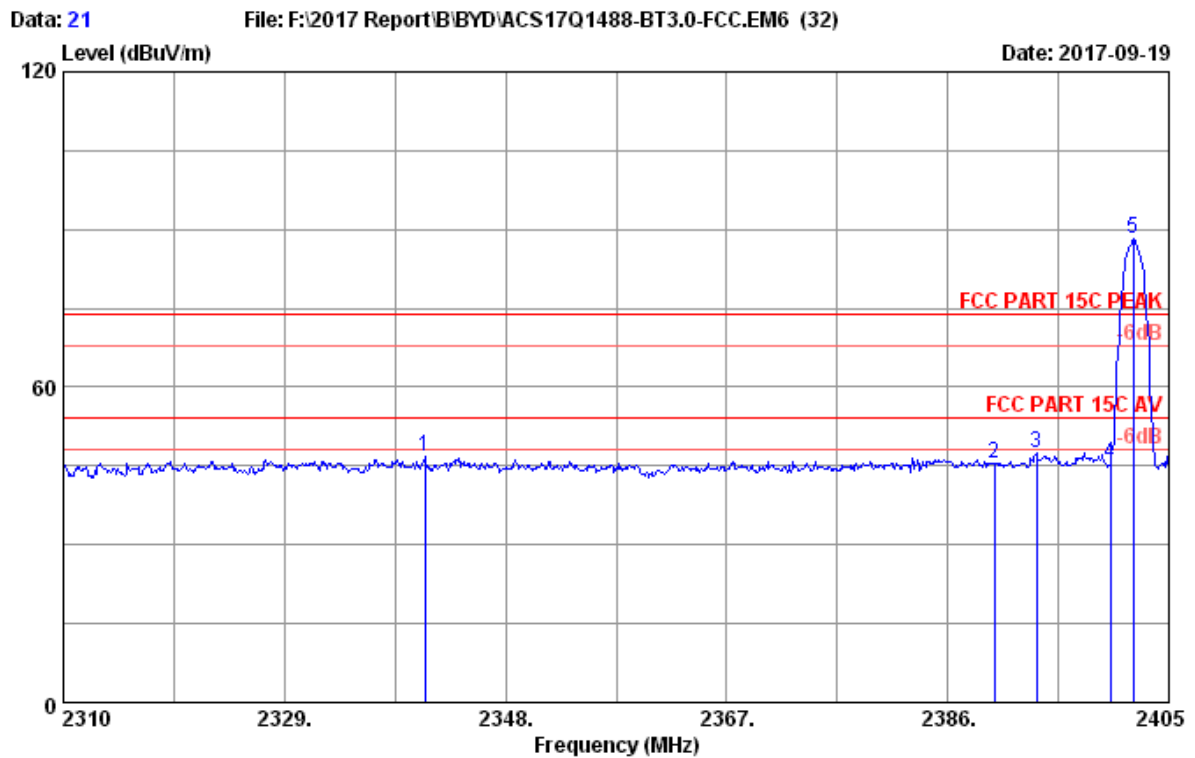

Site no. : 3m Chamber Data no. : 21
 Dis. / Ant. : 3m 2017 ANT 3006 HF Ant. pol. : HORIZONTAL
 Limit : FCC PART 15C PEAK
 Env. / Ins. : 23.1°C/52.8% Engineer : Lynn
 EUT : Notebook M/N:RZ09-0239
 Power rating : DC 20V From Adaptor Input AC 120V/60Hz
 Test Mode : 8-DPSK 2402 Tx Mode

No.	Freq. (MHz)	Ant. Factor (dB/m)	Cable Loss (dB)	Reading (dBuV)	Amp factor (dB)	Emission Level (dBuV/m)	Limits (dBuV/m)	Margin (dB)	Remark
1	2341.07	27.88	7.77	46.34	35.32	46.67	74.00	27.33	Peak
2	2390.00	27.96	7.84	45.12	35.33	45.59	74.00	28.41	Peak
3	2393.60	27.96	7.88	47.02	35.33	47.53	74.00	26.47	Peak
4	2400.00	27.96	7.88	44.85	35.33	45.36	74.00	28.64	Peak
5	2401.96	27.96	7.88	87.72	35.33	88.23	74.00	-14.23	Peak

Remarks: 1. Emission Level= Antenna Factor + Cable Loss + Reading -Amp factor.
 2. The emission levels that are 20dB below the official limit are not reported.

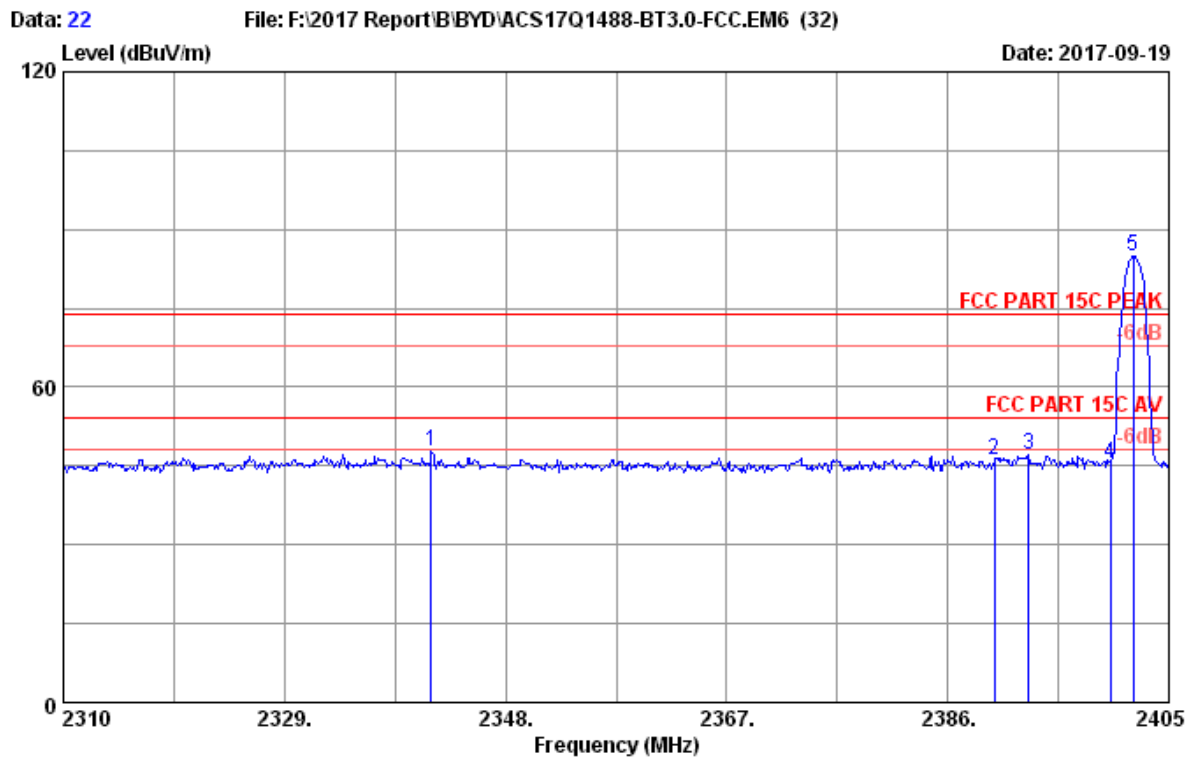

Site no. : 3m Chamber Data no. : 22
 Dis. / Ant. : 3m 2017 ANT 3006 HF Ant. pol. : VERTICAL
 Limit : FCC PART 15C PEAK
 Env. / Ins. : 23.1°C/52.8% Engineer : Lynn
 EUT : Notebook M/N:RZ09-0239
 Power rating : DC 20V From Adaptor Input AC 120V/60Hz
 Test Mode : 8-DPSK 2402 Tx Mode

No.	Freq. (MHz)	Ant. Factor (dB/m)	Cable Loss (dB)	Reading (dBuV)	Amp factor (dB)	Emission Level (dBuV/m)	Limits (dBuV/m)	Margin (dB)	Remark
1	2341.64	27.88	7.77	47.31	35.32	47.64	74.00	26.36	Peak
2	2390.00	27.96	7.84	45.54	35.33	46.01	74.00	27.99	Peak
3	2392.94	27.96	7.88	46.77	35.33	47.28	74.00	26.72	Peak
4	2400.00	27.96	7.88	44.91	35.33	45.42	74.00	28.58	Peak
5	2401.96	27.96	7.88	84.53	35.33	85.04	74.00	-11.04	Peak

Remarks: 1. Emission Level= Antenna Factor + Cable Loss + Reading -Amp factor.
 2. The emission levels that are 20dB below the official limit are not reported.

Data: 27

File: F:\2017 Report\B\BYD\ACS17Q1488-BT3.0-FCC.EM6 (32)

Date: 2017-09-19

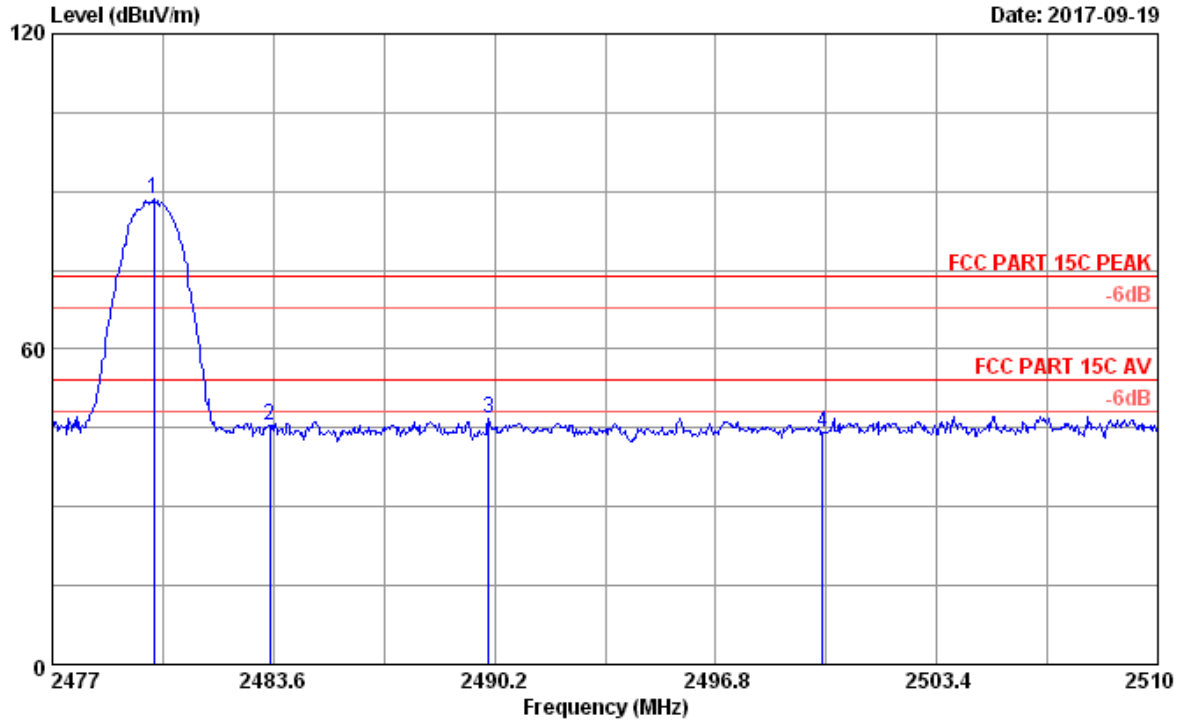

Site no. : 3m Chamber Data no. : 27
 Dis. / Ant. : 3m 2017 ANT 3006 HF Ant. pol. : HORIZONTAL
 Limit : FCC PART 15C PEAK
 Env. / Ins. : 23.1°C/52.8% Engineer : Lynn
 EUT : Notebook M/N:RZ09-0239
 Power rating : DC 20V From Adaptor Input AC 120V/60Hz
 Test Mode : 8-DPSK 2480 Tx Mode

No.	Freq. (MHz)	Ant. Factor (dB/m)	Cable Loss (dB)	Reading (dBuV)	Amp factor (dB)	Emission Level (dBuV/m)	Limits (dBuV/m)	Margin (dB)	Remark
1	2480.04	28.08	8.02	87.65	35.34	88.41	74.00	-14.41	Peak
2	2483.50	28.08	8.02	44.60	35.34	45.36	74.00	28.64	Peak
3	2490.04	28.10	8.05	45.92	35.34	46.73	74.00	27.27	Peak
4	2500.00	28.10	8.05	43.38	35.34	44.19	74.00	29.81	Peak

Remarks: 1. Emission Level= Antenna Factor + Cable Loss + Reading - Amp factor.
 2. The emission levels that are 20dB below the official limit are not reported.

Data: 28

File: F:\2017 Report\B\BYD\ACS17Q1488-BT3.0-FCC.EM6 (32)

Date: 2017-09-19

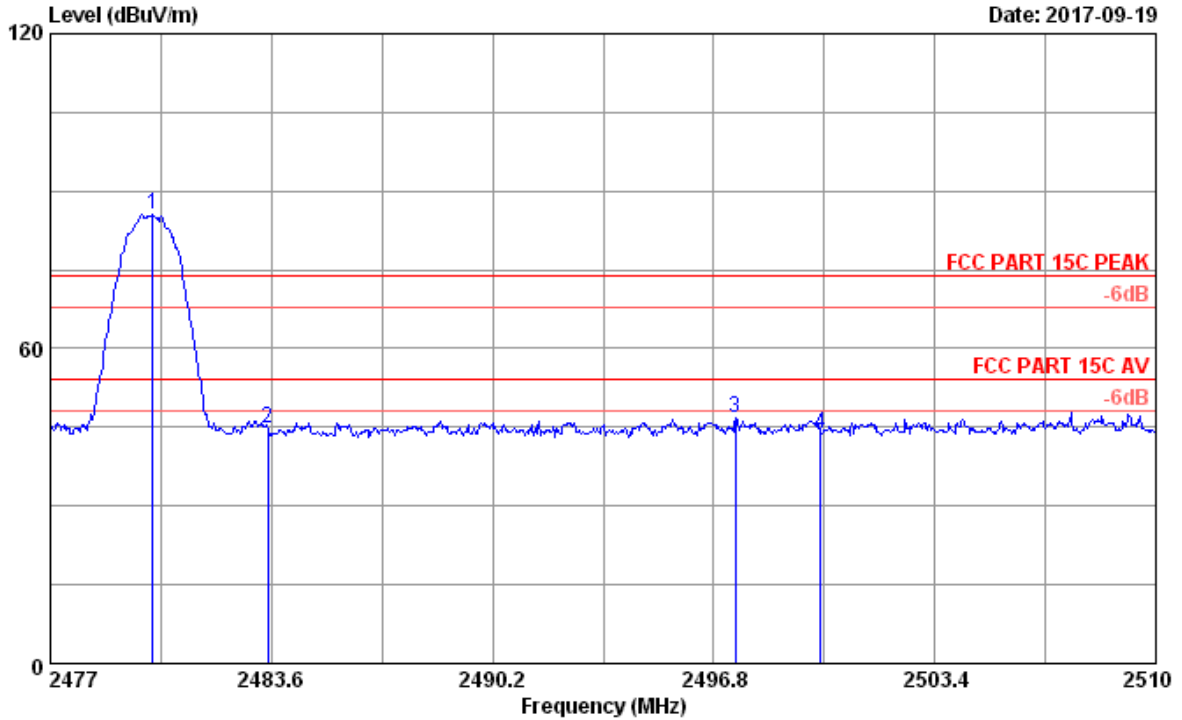

Site no. : 3m Chamber Data no. : 28
 Dis. / Ant. : 3m 2017 ANT 3006 HF Ant. pol. : VERTICAL
 Limit : FCC PART 15C PEAK
 Env. / Ins. : 23.1°C/52.8% Engineer : Lynn
 EUT : Notebook M/N:RZ09-0239
 Power rating : DC 20V From Adaptor Input AC 120V/60Hz
 Test Mode : 8-DPSK 2480 Tx Mode

No.	Freq. (MHz)	Ant. Factor (dB/m)	Cable Loss (dB)	Reading (dBuV)	Amp factor (dB)	Emission Level (dBuV/m)	Limits (dBuV/m)	Margin (dB)	Remark
1	2480.07	28.08	8.02	84.85	35.34	85.61	74.00	-11.61	Peak
2	2483.50	28.08	8.02	44.13	35.34	44.89	74.00	29.11	Peak
3	2497.46	28.10	8.05	45.84	35.34	46.65	74.00	27.35	Peak
4	2500.00	28.10	8.05	43.14	35.34	43.95	74.00	30.05	Peak

Remarks: 1. Emission Level= Antenna Factor + Cable Loss + Reading -Amp factor.
 2. The emission levels that are 20dB below the official limit are not reported.

13. ANTENNA REQUIREMENT

13.1. Standard Applicable

For intentional device, according to FCC 47 CFR Section 15.203, an intentional radiator shall be designed to ensure that no antenna other than that furnished by the responsible party shall be used with the device. And according to FCC 47 CFR Section 15.247 (b), if transmitting antennas of directional gain greater than 6dBi are used, the power shall be reduced by the amount in dB that the directional gain of the antenna exceeds 6dBi.

13.2. Antenna Connected Construction

The antennas used for this product are PIFA antenna that no antenna other than that furnished by the responsible party shall be used with the device, the maximum peak gain of the transmit antenna is 1.89dBi

14.DEVIATION TO TEST SPECIFICATIONS

[NONE]