

FCC SAR Test Report

FCC ID: RWO-RZ090166

Project No. : 1607C289
Equipment : Notebook
Model Name : RZ09-0166
Applicant : Razer Inc.
Address : 201 3rd Street, Suite 900, San Francisco, CA 94103

Date of Receipt : Jul. 28, 2016
Date of Test : Aug. 10, 2016 ~ Aug. 11, 2016
Issued Date : Aug. 12, 2016
Tested by : BTL Inc.

PREPARED BY : _____
(Super Jiang/ Technical Engineer)

APPROVED BY : _____
(Steven Lu / Technical Manager)

B T L I N C .

No.3, Jinshagang 1st Road, Shixia, Dalang Town, Dongguan,
Guangdong, China.

TEL: +86-769-8318-3000 FAX: +86-769-8319-6000



Declaration

BTL represents to the client that testing is done in accordance with standard procedures as applicable and that test instruments used has been calibrated with the standards traceable to National Measurement Laboratory (**NML**), or National Institute of Standards and Technology (**NIST**) .

BTL's reports apply only to the specific samples tested under conditions. It is manufacture's responsibility to ensure that additional production units of this model are manufactured with the identical electrical and mechanical components. **BTL** shall have no liability for any declarations, inferences or generalizations drawn by the client or others from **BTL** issued reports.

BTL's reports must not be used by the client to claim product endorsement by the authorities or any agency of the Government.

This report is the confidential property of the client. As a mutual protection to the clients, the public and **BTL-self**, extracts from the test report shall not be reproduced except in full with **BTL's** authorized written approval.

BTL's laboratory quality assurance procedures are in compliance with the **ISO Guide17025** requirements, and accredited by the conformity assessment authorities listed in this test report.

Limitation

For the use of the authority's logo is limited unless the Test Standard(s)/Scope(s)/Item(s) mentioned in this test report is (are) included in the conformity assessment authorities acceptance respective.

Table of Contents	Page
1 . GENERAL SUMMARY	6
2 . RF EMISSIONS MEASUREMENT	7
2.1 TEST FACILITY	7
2.2 MEASUREMENT UNCERTAINTY	7
3 . GENERAL INFORMATION	8
3.1 STATEMENT OF COMPLIANCE	8
3.2 GENERAL DESCRIPTION OF EUT	9
3.3 LABORATORY ENVIRONMENT	9
3.4 MAIN TEST INSTRUMENTS	10
4 .SAR MEASUREMENTS SYSTEM CONFIGURATION	11
4.1 SAR MEASUREMENT SET-UP	11
4.2 DASY5E-FIELDPROBESYSTEM	12
5 . SYSTEM VERIFICATION PROCEDURE	21
5.1 TISSUE VERIFICATION	21
5.2 SYSTEM CHECK	22
5.3 SYSTEM CHECK PROCEDURE	23
6 .SAR MEASUREMENT VARIABILITY AND UNCERTAINTY	24
6.1 SAR MEASUREMENT VARIABILITY	24
7 . OPERATIONAL CONDITIONS DURING TEST	25
7.1 SAR TEST CONFIGURATION	25
7.2 TEST POSITION OF PORTABLE DEVICES	28
8 . POWER TEST RESULT	29
8.1 CONDUCTED POWER MEASUREMENTS OF BT	29
8.2 CONDUCTED POWER MEASUREMENTS OF WIFI 2.4G	30
8.3 CONDUCTED POWER MEASUREMENTS OF WIFI 5G	31
9. SAR TEST RESULTS	35
9.1 SAR MEASUREMENT RESULT	36
10. MULTIPLE TRANSMITTER INFORMATION	37
11. SIMULTANEOUS TRANSMISSION CONDITIONS	37

Table of Contents	Page
APPENDIX	38
1. TEST LAYOUT	38
Appendix A. SAR Plots of System Verification	
Appendix B. SAR Plots of SAR Measurement	
Appendix C. Calibration Certificate for Probe and Dipole	
Appendix D. Photographs of the Test Set-Up	

REPORT ISSUED HISTORY

Issued No.	Description	Issued Date
BTL-FCC SAR-1-1607C289	Original Issue.	Aug. 12, 2016

1. GENERAL SUMMARY

Equipment	Notebook
Model Name	RZ09-0166
Brand Name	RAZER
Manufacturer	Razer Inc.
Address	201 3rd Street, Suite 900, San Francisco, CA 94103
Standard(s)	<p>FCC 47CFR §2.1093 Radio frequency Radiation Exposure Evaluation: Portable Devices</p> <p>ANSI Std C95.1-1992 Safety Levels with Respect to Human Exposure to Radio Frequency Electromagnetic Fields, 3 kHz – 300 GHz.(IEEE Std C95.1-1991)</p> <p>IEEE Std 1528-2013 Recommended Practice for Determining the Peak Spatial-Average Specific Absorption Rate (SAR) in the Human Head from Wireless Communications Devices: Measurement Techniques</p> <p>KDB447498 D01 General RF Exposure Guidance v06 KDB616217 D04 SAR for laptop and tablets v01r02 KDB248227 D01 802. 11 Wi-Fi SAR v02r02 KDB865664 D01 SAR measurement 100 MHz to 6 GHz v01r04 KDB865664 D02 RF Exposure Reporting v01r02 KDB690783 D01 SAR Listings on Grants v01r03</p>

The above equipment has been tested and found compliance with the requirement of the relative standards by BTL Inc.

The test data, data evaluation, and equipment configuration contained in our test report (Ref No. BTL-FCC SAR-1-1607C289) were obtained utilizing the test procedures, test instruments, test sites that has been accredited by the Authority of TAF according to the ISO-17025 quality assessment standard and technical standard(s).

2. RF EMISSIONS MEASUREMENT

2.1 TEST FACILITY

The test facilities used to collect the test data in this report is **SAR room** at the location of No.3,Jinshagang 1st Road, ShiXia, Dalang Town,Dong Guan, China.523792

2.2 MEASUREMENT UNCERTAINTY

Note: Per KDB865664 D01 SAR Measurement 100 MHz to 6 GHz v01r04,when the highest measured 1-g SAR within a frequency band is < 1.5 W/kg, the extensive SAR measurement uncertainty analysis described in IEEE Std 1528-2013 is not required in SAR reports submitted for equipment approval. The equivalent ratio (1.5/1.6) is applied to extremity and occupational exposure conditions.

3. GENERAL INFORMATION

3.1 STATEMENT OF COMPLIANCE

The maximum results of Specific Absorption Rate (SAR) found during testing for RZ09-0166 is as below Table.

Equipment Class	Mode	Highest Body (0mm) SAR-1g(W/kg)
DTS	2.4G WLAN MIMO	0.14
NII	5.3G WLAN MIMO	0.72
	5.6G WLAN MIMO	0.38
	5.8G WLAN MIMO	0.45
DSS	Bluetooth	-
The highest simultaneous SAR value is 0.72 W/kg per KDB690783 D01		

Note:

The device is in compliance with Specific Absorption Rate (SAR) for general population/ uncontrolled exposure limits according to the FCC rule §2.1093, the ANSI/IEEE C95.1:1992, the NCRP Report Number 86 for uncontrolled environment, and had been tested in accordance with the measurement methods and procedures specified in IEEE Std 1528-2013.

3.2 GENERAL DESCRIPTION OF EUT

Equipment	Notebook				
Model Name	RZ09-0166				
S/N	F120160716DVTSKU10Z				
HW Version	F1_MB				
SW Version	Windows 10				
Modulation	WiFi(DSSS/OFDM),BT(GFSK/ $\pi/4$ -DQPSK/8-DPSK)				
Operation Frequency Range(s)	Band	TX (MHz)		RX (MHz)	
	Bluetooth	2400 ~2483.5			
	WIFI	2412 ~2462			
		5150 ~5250			
		5250 ~5350			
		5470 ~5725			
		5725 ~5850			
Test Channels (low-mid-high):	0-39-78(BT)				
	1-6-11 (2.4G WIFI 802.11b/g/nHT20)				
	5G WIFI	Band 1	Band 2	Band 3	Band 4
	a/n20/ ac20	36-40-44-48	52-56-60-64	100-104-108-112- 116-132-136-140	149-153-157 -161-165
	n40/ ac40	38-46	54-62	102-134	151-159
	ac80	42	58	106-122	155
Antenna Gain	BT ANT2:1.15dBi				
	2.4G WiFi ANT1:1.68dBi ANT2:1.15dBi				
	5G WiFi Band 1 ANT1:0.26dBi ANT2:0.23dBi				
	Band 2 ANT1:0.48dBi ANT2:0.36dBi				
	Band 3 ANT1:0.78dBi ANT2:0.24dBi				
Band 4 ANT1:0.17dBi ANT2:0.07dBi					

3.3 LABORATORY ENVIRONMENT

Temperature	Min. = 18°C, Max. = 25°C
Relative humidity	Min. = 30%, Max. = 70%
Ground system resistance	< 0.5Ω
Ambient noise is checked and found very low and in compliance with requirement of standards. Reflection of surrounding objects is minimized and in compliance with requirement of standards.	

3.4 MAIN TEST INSTRUMENTS

Item	Equipment	Manufacturer	Model	Serial No.	Cal. Date	Cal. Interval
1	Data Acquisition Electronics	Speag	DAE4	1390	Sep. 18, 2015	1 Year
2	E-field Probe	Speag	EX3DV4	3932	Feb. 19, 2016	1 Year
3	System Validation Dipole	Speag	D2450V2	919	Sep. 28, 2015	1 Year
4	System Validation Dipole	Speag	D5GHzV2	1160	Oct. 05, 2015	1 Year
5	ELI4 Phantom	Speag	ELI4 Phantom V5.0	1222	NA	NA
6	Power Amplifier	Mini-Circuits	ZHL-42W+	QA1333003	NA	NA
7	Power Amplifier	Mini-Circuits	ZVE-8G+	520701341	NA	NA
8	ENA Network Analyzer	Agilent	E5071C	MY46102965	Mar. 27, 2016	1 Year
9	MXG Analog Signal Generator	Agilent	N5181A	MY49060710	Oct. 11, 2015	1 Year
10	P-series power meter	Agilent	N1911A	MY45100473	Oct. 26, 2015	1 Year
11	wideband power sensor	Agilent	N1921A	MY51100041	Oct. 26, 2015	1 Year
12	power Meter	Anritsu	ML2495A	1128009	Mar. 27, 2016	1 Year
13	Pulse Power Sensor	Anritsu	MA 2411B	1027500	Mar. 27, 2016	1 Year
14	Dielectric Assessment Kit	Speag	DAK-3.5	1226	NA	NA
15	Dual directional coupler	Woken	TS-PCC0M-05	107090019	Mar. 16, 2016	1 Year

Remark: " N/A" denotes no model name, serial No. or calibration specified.
All calibration period of equipment list is one year.

4.SAR MEASUREMENTS SYSTEM CONFIGURATION

4.1SAR MEASUREMENT SET-UP

The DASY5 system for performing compliance tests consists of the following items:

1. A standard high precision 6-axis robot (Stäubli RX family) with controller and software. An arm extension for accommodating the data acquisition electronics (DAE).
2. A dosimetric probe, i.e. an isotropic E-field probe optimized and calibrated for usage in tissue simulating liquid. The probe is equipped with an optical surface detector system.
3. A data acquisition electronic (DAE) which performs the signal amplification, signal multiplexing, AD-conversion, offset measurements, mechanical surface detection, collision detection, etc. The unit is battery powered with standard or rechargeable batteries. The signal is optically transmitted to the EOC.
4. A unit to operate the optical surface detector which is connected to the EOC.
5. The Electro-Optical Coupler (EOC) performs the conversion from the optical into a digital electric signal of the DAE. The EOC is connected to the DASY5 measurement server.
6. The DASY5 measurement server, which performs all real-time data evaluation for field measurements and surface detection, controls robot movements and handles safety operation. A computer operating Windows 7
7. DASY5 software and SEMCAD data evaluation software.
8. Remote control with teach panel and additional circuitry for robot safety such as warning lamps, etc.
9. The generic twin phantom enabling the testing of left-hand and right-hand usage.
10. The device holder for handheld mobile phones.
11. Tissue simulating liquid mixed according to the given recipes.
12. System validation dipoles allowing to validate the proper functioning of the system.

4.1.1Test Setup Layout

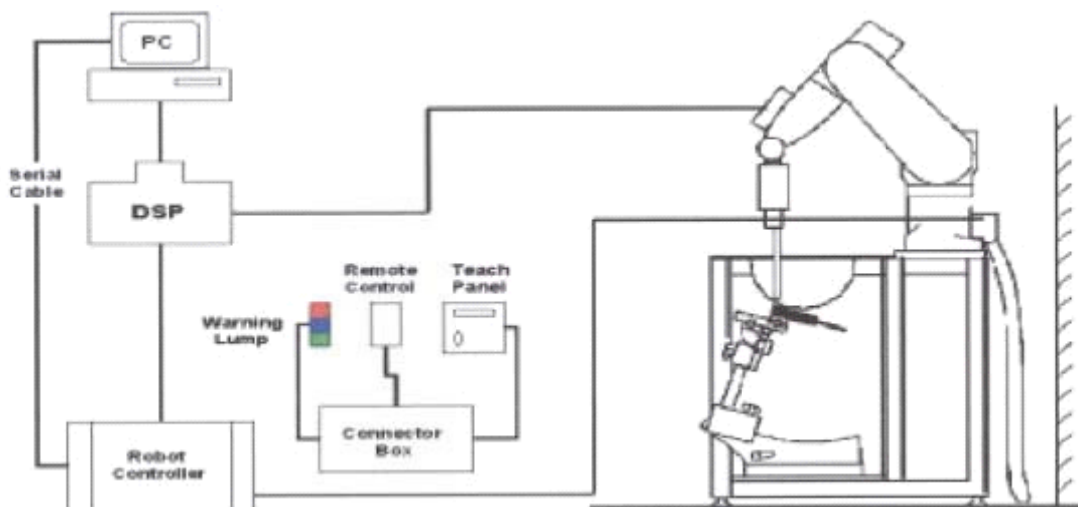

4.2 DASY5E-FIELD PROBE SYSTEM

The SAR measurements were conducted with the dosimetric probe EX3DV4 (manufactured by SPEAG), designed in the classical triangular configuration and optimized for dosimetric evaluation.

4.2.1 EX3DV4 PROBE SPECIFICATION

Construction	Symmetrical design with triangular core Interleaved sensors Built-in shielding against static charges PEEK enclosure material (resistant to organic solvents, e.g., DGBE)
Calibration	ISO/IEC 17025 calibration service available
Frequency	10 MHz to 6 GHz Linearity: ± 0.2 dB (30 MHz to 6 GHz)
Directivity	± 0.3 dB in HSL (rotation around probe axis) ± 0.5 dB in tissue material (rotation normal to probe axis)
Dynamic Range	10 μ W/g to > 100 mW/g Linearity: ± 0.2 dB
Dimensions	Overall length: 330 mm (Tip: 20 mm) Tip diameter: 2.5 mm (Body: 12 mm) Distance from probe tip to dipole centers: 1.0 mm

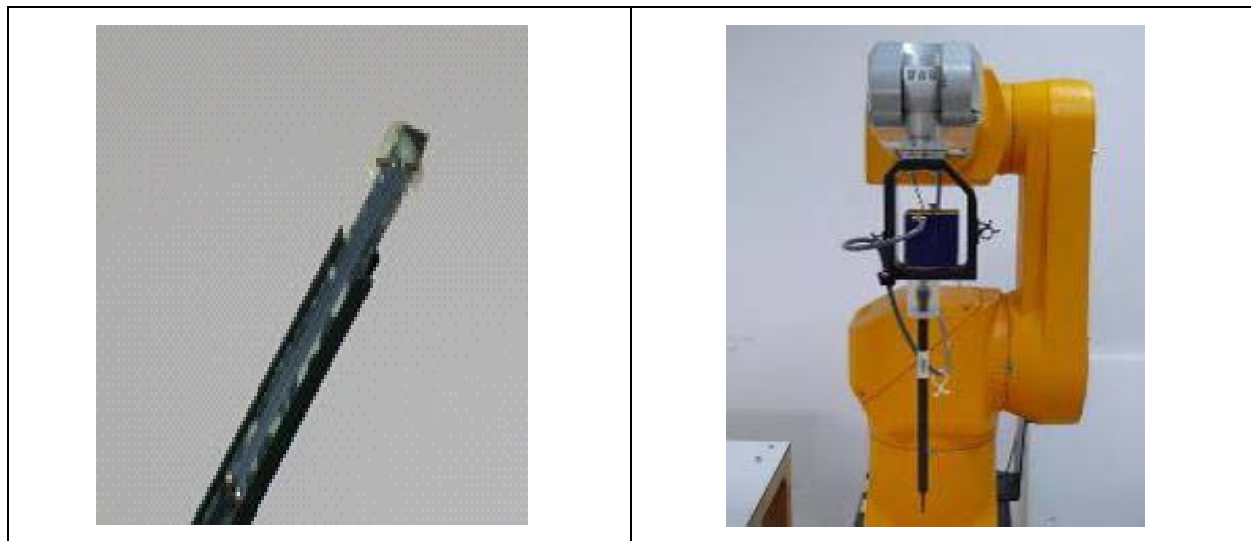

EX3DV4 E-field Probe

4.2.2 E-FIELD PROBE CALIBRATION

Each probe is calibrated according to a dosimetric assessment procedure with accuracy better than $\pm 10\%$. The spherical isotropy was evaluated and found to be better than $\pm 0.25\text{dB}$. The sensitivity parameters (NormX, NormY, NormZ), the diode compression parameter (DCP) and the conversion factor (ConvF) of the probe are tested.

The free space E-field from amplified probe outputs is determined in a test chamber. This is performed in a TEM cell for frequencies below 1 GHz, and in a wave guide above 1 GHz for free space. For the free space calibration, the probe is placed in the volumetric center of the cavity and at the proper orientation with the field. The probe is then rotated 360 degrees.

E-field temperature correlation calibration is performed in a flat phantom filled with the appropriate simulated brain tissue. The measured free space E-field in the medium correlates to temperature rise in a dielectric medium. For temperature correlation calibration a RF transparent thermistor-based temperature probe is used in conjunction with the E-field probe.

$$\text{SAR} = C \frac{\Delta T}{\Delta t}$$

Where: Δt = Exposure time (30 seconds),

C = Heat capacity of tissue (brain or muscle),

ΔT = Temperature increase due to RF exposure.

Or
$$\text{SAR} = \frac{|E|^2 \sigma}{\rho}$$

Where: σ = Simulated tissue conductivity,

ρ = Tissue density (kg/m^3).

4.2.3 OTHER TEST EQUIPMENT

4.2.3.1 Device Holder for Transmitters

Construction: Simple but effective and easy-to-use extension for Mounting Device that facilitates the testing of larger devices (e.g., laptops, cameras, etc.) It is light weight and fits easily on the upper part of the Mounting Device in place of the phone positioner. The extension is fully compatible with the Twin SAM, ELI4 and SAM v6.0 Phantoms.

Material: POM, Acrylic glass, Foam

4.2.3.2 Phantom

Model	ELI4 Phantom	
Construction	Phantom for compliance testing of handheld and body-mounted wireless devices in the frequency range of 30 MHz to 6 GHz. ELI is fully compatible with the IEC 62209-2 standard and all known tissue simulating liquids. ELI has been optimized regarding its performance and can be integrated into our standard phantom tables. A cover prevents evaporation of the liquid. Reference markings on the phantom allow installation of the complete setup, including all predefined phantom positions and measurement grids, by teaching three points. The phantom is compatible with all SPEAG dosimetric probes and dipoles.	
Shell Thickness	2±0.1 mm	
Filling Volume	Approx. 30 liters	
Dimensions	Length: 600 mm ; Width: 190mm Height: adjustable feet	
Available	Special	

Model	Twin SAM	
Construction	The shell corresponds to the specifications of the Specific Anthropomorphic Mannequin (SAM) phantom defined in IEEE 1528 and IEC 62209-1. It enables the dosimetric evaluation of left and right hand phone usage as well as body mounted usage at the flat phantom region. A cover prevents evaporation of the liquid. Reference markings on the phantom allow the complete setup of all predefined phantom positions and measurement grids by teaching three points with the robot.	
Shell Thickness	2 ± 0.2 mm	
Filling Volume	Approx. 25 liters	
Dimensions	Length:1000mm; Width: 500mm Height: adjustable feet	
Available	Special	

4.2.4 SCANNING PROCEDURE

The DASY5 installation includes predefined files with recommended procedures for measurements and validation. They are read-only document files and destined as fully defined but unmeasured masks. All test positions (head or body-worn) are tested with the same configuration of test steps differing only in the grid definition for the different test positions.

The “reference” and “drift” measurements are located at the beginning and end of the batch process. They measure the field drift at one single point in the liquid over the complete procedure. The indicated drift is mainly the variation of the DUT’s output power and should vary max. $\pm 5\%$.

The “surface check” measurement tests the optical surface detection system of the DASY5 system by repeatedly detecting the surface with the optical and mechanical surface detector and comparing the results. The output gives the detecting heights of both systems, the difference between the two systems and the standard deviation of the detection repeatability. Air bubbles or refraction in the liquid due to separation of the sugar-water mixture gives poor repeatability (above $\pm 0.1\text{mm}$). To prevent wrong results tests are only executed when the liquid is free of air bubbles. The difference between the optical surface detection and the actual surface depends on the probe and is specified with each probe. (It does not depend on the surface reflectivity or the probe angle to the surface within $\pm 30^\circ$.)

- Area Scan

The “area scan” measures the SAR above the DUT or verification dipole on a parallel plane to the surface. It is used to locate the approximate location of the peak SAR with 2D spline interpolation. The robot performs a stepped movement along one grid axis while the local electrical field strength is measured by the probe. The probe is touching the surface of the SAM during acquisition of measurement values. The standard scan uses large grid spacing for faster measurement. Standard grid spacing for head measurements is 15 mm in x- and y-dimension ($\leq 2\text{GHz}$), 12 mm in x- and y-dimension (2-4 GHz) and 10mm in x- and y-dimension (4-6GHz). If a finer resolution is needed, the grid spacing can be reduced. Grid spacing and orientation have no influence on the SAR result. For special applications where the standard scan method does not find the peak SAR within the grid, e.g. mobile phones with flip cover, the grid can be adapted in orientation.

- Zoom Scan

A “zoom scan” measures the field in a volume around the 2D peak SAR value acquired in the previous “coarse” scan. This is a fine grid with maximum scan spatial resolution: $\Delta x_{\text{zoom}}, \Delta y_{\text{zoom}} \leq 2\text{GHz} - \leq 8\text{mm}$, 2-4GHz - $\leq 5\text{mm}$ and 4-6 GHz - $\leq 4\text{mm}$; $\Delta z_{\text{zoom}} \leq 3\text{GHz} - \leq 5\text{mm}$, 3-4 GHz - $\leq 4\text{mm}$ and 4-6GHz - $\leq 2\text{mm}$ where the robot additionally moves the probe along the z-axis away from the bottom of the Phantom. DASY is also able to perform repeated zoom scans if more than 1 peak is found during area scan. In this document, the evaluated peak 1g and 10g averaged SAR values are shown in the 2D-graphics in Appendix B. Test results relevant for the specified standard (see chapter 1.4.) are shown in table form in chapter 7.2.

A Z-axis scan measures the total SAR value at the x- and y-position of the maximum SAR value found during the cube scan. The probe is moved away in z-direction from the bottom of the SAM phantom in 2 mm steps. This measurement shows the continuity of the liquid and can - depending in the field strength - also show the liquid depth.

The following table summarizes the area scan and zoom scan resolutions per FCC KDB 865664D01:

Frequency	Maximun Area Scan resolution ($\Delta x_{area}, \Delta y_{area}$)	Maximun Zoom Scan spatial resolution ($\Delta x_{zoom}, \Delta y_{zoom}$)	Maximun Zoom Scan spatial resolution			Minimum zoom scan volume (x,y,z)
			Uniform Grid	Graded Grad		
			$\Delta z_{zoom}(n)$	$\Delta z_{zoom}(1)^*$	$\Delta z_{zoom}(n>1)^*$	
$\leq 2\text{GHz}$	$\leq 15\text{mm}$	$\leq 8\text{mm}$	$\leq 5\text{mm}$	$\leq 4\text{mm}$	$\leq 1.5^* \Delta z_{zoom}(n-1)$	$\geq 30\text{mm}$
2-3GHz	$\leq 12\text{mm}$	$\leq 5\text{mm}$	$\leq 5\text{mm}$	$\leq 4\text{mm}$	$\leq 1.5^* \Delta z_{zoom}(n-1)$	$\geq 30\text{mm}$
3-4GHz	$\leq 12\text{mm}$	$\leq 5\text{mm}$	$\leq 4\text{mm}$	$\leq 3\text{mm}$	$\leq 1.5^* \Delta z_{zoom}(n-1)$	$\geq 28\text{mm}$
4-5GHz	$\leq 10\text{mm}$	$\leq 4\text{mm}$	$\leq 3\text{mm}$	$\leq 2.5\text{mm}$	$\leq 1.5^* \Delta z_{zoom}(n-1)$	$\geq 25\text{mm}$
5-6GHz	$\leq 10\text{mm}$	$\leq 4\text{mm}$	$\leq 2\text{mm}$	$\leq 2\text{mm}$	$\leq 1.5^* \Delta z_{zoom}(n-1)$	$\geq 22\text{mm}$

4.2.5 SPATIAL PEAK SAR EVALUATION

The spatial peak SAR - value for 1 and 10 g is evaluated after the Cube measurements have been done. The basis of the evaluation are the SAR values measured at the points of the fine cube grid consisting of 5 x 5 x 7 points(with 8mm horizontal resolution) or 7 x 7 x 7 points(with 5mm horizontal resolution) or 8 x 8 x 7 points(with 4mm horizontal resolution). The algorithm that finds the maximal averaged volume is separated into three different stages.

- The data between the dipole center of the probe and the surface of the phantom are extrapolated. This data cannot be measured since the center of the dipole is 2.7 mm away from the tip of the probe and the distance between the surface and the lowest measuring point is about 1 mm (see probe calibration sheet). The extrapolated data from a cube measurement can be visualized by selecting “Graph Evaluated”.
- The maximum interpolated value is searched with a straight-forward algorithm. Around this maximum the SAR - values averaged over the spatial volumes (1g or 10 g) are computed using the 3d-spline interpolation algorithm. If the volume cannot be evaluated (i.e., if a part of the grid was cut off by the boundary of the measurement area) the evaluation will be started on the corners of the bottom plane of the cube.
- All neighboring volumes are evaluated until no neighboring volume with a higher average value is found.

Extrapolation

The extrapolation is based on a least square algorithm [W. Gander, Computermathematik, p.168-180]. Through the points in the first 3 cm along the z-axis, polynomials of order four are calculated. These polynomials are then used to evaluate the points between the surface and the probe tip. The points, calculated from the surface, have a distance of 1 mm from each other.

Interpolation

The interpolation of the points is done with a 3d-Spline. The 3d-Spline is composed of three one-dimensional splines with the "Not a knot"-condition [W. Gander, Computermathematik, p.141-150] (x, y and z -direction) [Numerical Recipes in C, Second Edition, p.123ff].

Volume Averaging

At First the size of the cube is calculated. Then the volume is integrated with the trapezoidal algorithm. 8000 points (20x20x20) are interpolated to calculate the average.

Advanced Extrapolation

DASY5 uses the advanced extrapolation option which is able to compensate boundary effects on E-field probes.

4.2.6 DATA STORAGE AND EVALUATION

4.2.5.1 Data Storage

The DASY5 software stores the acquired data from the data acquisition electronics as raw data (in microvolt readings from the probe sensors), together with all necessary software parameters for the data evaluation (probe calibration data, liquid parameters and device frequency and modulation data) in measurement files with the extension “.DAE4”. The software evaluates the desired unit and format for output each time the data is visualized or exported. This allows verification of the complete software setup even after the measurement and allows correction of incorrect parameter settings. For example, if a measurement has been performed with a wrong crest factor parameter in the device setup, the parameter can be corrected afterwards and the data can be re-evaluated.

The measured data can be visualized or exported in different units or formats, depending on the selected probe type ([V/m], [A/m], [°C], [mW/g], [mW/cm²], [dBrel], etc.). Some of these units are not available in certain situations or show meaningless results, e.g., a SAR output in a lossless media will always be zero. Raw data can also be exported to perform the evaluation with other software packages.

4.4.2 Data Evaluation by SEMCAD

The SEMCAD software automatically executes the following procedures to calculate the field units from the microvolt readings at the probe connector. The parameters used in the evaluation are stored in the configuration modules of the software:

Probe parameters:	Sensitivity	Normi, a _{i0} , a _{i1} , a _{i2}
	Conversion factor	ConvF _i
	Diode compression point	Dcp _i
Device parameters:	Frequency	f
	Crest factor	cf
Media parameters:	Conductivity	
	Density	

These parameters must be set correctly in the software. They can be found in the component documents or they can be imported into the software from the configuration files issued for the DASY5 components. In the direct measuring mode of the multi meter option, the parameters of the actual system setup are used. In the scan visualization and export modes, the parameters stored in the corresponding document files are used.

The first step of the evaluation is a linearization of the filtered input signal to account for the compression characteristics of the detector diode. The compensation depends on the input signal, the diode type and the DC-transmission factor from the diode to the evaluation electronics.

If the exciting field is pulsed, the crest factor of the signal must be known to correctly compensate for peak power. The formula for each channel can be given as:

$$V_i = U_i + U_i^2 \cdot cf / dcp_i$$

With	V _i = compensated signal of channel i	(i = x, y, z)
	U _i = input signal of channel i	(i = x, y, z)
	cf = crest factor of exciting field	(DASY parameter)
	dcp _i = diode compression point	(DASY parameter)

From the compensated input signals the primary field data for each channel can be evaluated:

$$E\text{-field probes: } E_i = (V_i / \text{Norm}_i \cdot \text{ConvF})^{1/2}$$

$$H\text{-field probes: } H_i = (V_i)^{1/2} \cdot (a_{i0} + a_{i1} f + a_{i2} f^2) / f$$

With V_i = compensated signal of channel i ($i = x, y, z$)

Norm_i = sensor sensitivity of channel i ($i = x, y, z$)
[mV/(V/m)²] for E-field Probes

ConvF = sensitivity enhancement in solution

a_{ij} = sensor sensitivity factors for H-field probes

f = carrier frequency [GHz]

E_i = electric field strength of channel i in V/m

H_i = magnetic field strength of channel i in A/m

The RSS value of the field components gives the total field strength (Hermitian magnitude):

$$E_{\text{tot}} = (E_x^2 + E_y^2 + E_z^2)^{1/2}$$

The primary field data are used to calculate the derived field units.

$$\text{SAR} = (E_{\text{tot}})^2 \cdot \sigma / (\rho \cdot 1000)$$

With SAR = local specific absorption rate in mW/g

E_{tot} = total field strength in V/m
= conductivity in [mho/m] or [Siemens/m]
= equivalent tissue density in g/cm³

Note that the density is normally set to 1 (or 1.06), to account for actual brain density rather than the density of the simulation liquid. The power flow density is calculated assuming the excitation field to be a free space field.

$$P_{\text{pwe}} = E_{\text{tot}}^2 / 3770 \text{ or } P_{\text{pwe}} = H_{\text{tot}}^2 \cdot 37.7$$

With P_{pwe} = equivalent power density of a plane wave in mW/cm²

E_{tot} = total field strength in V/m

H_{tot} = total magnetic field strength in A/m

5. SYSTEM VERIFICATION PROCEDURE

5.1 TISSUE VERIFICATION

The simulating liquids should be checked at the beginning of a series of SAR measurements to determine if the dielectric parameters are within the tolerances of the specified target values. The measured conductivity and relative permittivity should be within $\pm 5\%$ of the target values.

The following materials are used for producing the tissue-equivalent materials.

Tissue Type	Bactericide	DGBE	HEC	NaCl	Sucrose	Triton X-100	Water	Diethylene Glycol Mono-hexylether
Body 2450	-	31.4	-	0.1	-	-	68.5	-
Body 5G	-	-	-	-	-	10.7	78.6	10.7

Salt: 99+% Pure Sodium Chloride; Sugar: 98+% Pure Sucrose; Water: De-ionized, 16M + resistivity
 HEC: Hydroxyethyl Cellulose; DGBE: 99+% Di(ethylene glycol) butyl ether, [2-(2-butoxyethoxy)ethanol]
 Triton X-100(ultra pure): Polyethylene glycol mono [4-(1,1,3,3-tetramethylbutyl)phenyl]ether

Tissue Verification									
Tissue Type	Frequency (MHz)	Liquid Temp. (°C)	Conductivity (σ)	Permittivity (ϵ_r)	Targeted Conductivity (σ)	Targeted Permittivity (ϵ_r)	Deviation Conductivity (σ) (%)	Deviation Permittivity (ϵ_r) (%)	Date
Body	2450	22.4	1.989	50.350	1.95	52.7	2.00	-4.46	Aug. 11, 2016
Body	5200	22.6	5.307	47.680	5.30	49.0	0.13	-2.69	Aug. 10, 2016
Body	5300	22.6	5.506	47.440	5.42	48.9	1.59	-2.99	Aug. 10, 2016
Body	5600	22.6	5.818	47.000	5.77	48.5	0.83	-3.09	Aug. 10, 2016
Body	5800	22.6	6.141	46.580	6.00	48.2	2.35	-3.36	Aug. 10, 2016

Note:

- 1) The dielectric parameters of the tissue-equivalent liquid should be measured under similar ambient conditions and within 2 °C of the conditions expected during the SAR evaluation to satisfy protocol requirements.
- 2) KDB 865664 was ensured to be applied for probe calibration frequencies greater than or equal to 50MHz of the EUT frequencies.
- 3) The above measured tissue parameters were used in the DASY software to perform interpolation via the DASY software to determine actual dielectric parameters at the test frequencies. The SAR test plots may slightly differ from the table above since the DASY rounds to three significant digits.

5.2 SYSTEM CHECK

The system check is performed for verifying the accuracy of the complete measurement system and performance of the software. The system check is performed with tissue equivalent material according to IEEE P1528 (described above). The following table shows system check results for all frequency bands and tissue liquids used during the tests.

System Check	Date	Frequency (MHz)	Targeted SAR (W/kg)	Measured SAR (W/kg)	normalized SAR (W/kg)	Deviation (%)	Dipole S/N
Body	Aug. 11, 2016	2450	51.10	13.10	52.40	2.54	1160
Body	Aug. 10, 2016	5200	77.80	7.68	76.80	-1.29	1160
Body	Aug. 10, 2016	5300	78.40	8.09	80.90	3.19	1160
Body	Aug. 10, 2016	5600	81.50	8.69	86.90	6.63	1160
Body	Aug. 10, 2016	5800	78.30	8.32	83.20	6.26	1160

5.3 SYSTEM CHECK PROCEDURE

The system check is performed by using a system check dipole which is positioned parallel to the planar part of the SAM phantom at the reference point. The distance of the dipole to the SAM phantom is determined by a plexiglass spacer. The dipole is connected to the signal source consisting of signal generator and amplifier via a directional coupler, N-connector cable and adaption to SMA. It is fed with a power of 250 mW (below 5GHz) or 100mW (above 5GHz). To adjust this power a power meter is used. The power sensor is connected to the cable before the system check to measure the power at this point and do adjustments at the signal generator. At the outputs of the directional coupler both return loss as well as forward power are controlled during the system check to make sure that emitted power at the dipole is kept constant. This can also be checked by the power drift measurement after the test.

System check results have to be equal or near the values determined during dipole calibration (target SAR in table above) with the relevant liquids and test system.

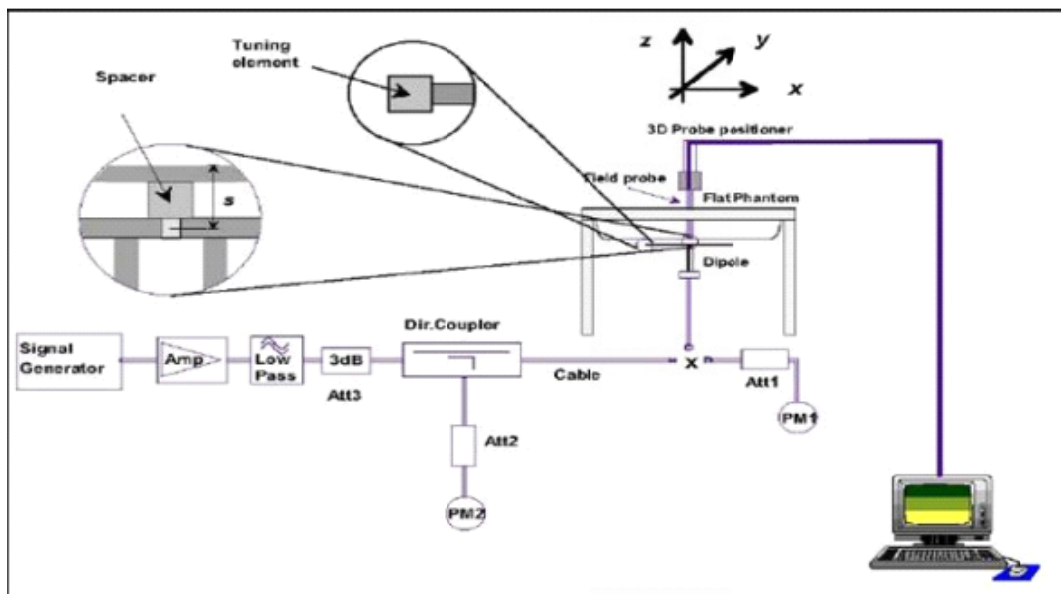

6.SAR MEASUREMENT VARIABILITY AND UNCERTAINTY

6.1 SAR MEASUREMENT VARIABILITY

Per KDB865664 D01 SAR measurement 100 MHz to 6 GHz v01r04, SAR measurement variability must be assessed for each frequency band, which is determined by the SAR probe calibration point and tissue-equivalent medium used for the device measurements. The additional measurements are repeated after the completion of all measurements requiring the same head or body tissue-equivalent medium in a frequency band. The test device should be returned to ambient conditions (normal room temperature) with the battery fully charged before it is re-mounted on the device holder for the repeated measurement(s) to minimize any unexpected variations in the repeated results.

- 1) Repeated measurement is not required when the original highest measured SAR is < 0.80 W/kg; steps 2) through 4) do not apply.
- 2) When the original highest measured SAR is ≥ 0.80 W/kg, repeat that measurement once.
- 3) Perform a second repeated measurement only if the ratio of largest to smallest SAR for the original and first repeated measurements is > 1.20 or when the original or repeated measurement is ≥ 1.45 W/kg (~ 10% from the 1-g SAR limit).
- 4) Perform a third repeated measurement only if the original, first or second repeated measurement is ≥ 1.5 W/kg and the ratio of largest to smallest SAR for the original, first and second repeated measurements is > 1.20 .

The same procedures should be adapted for measurements according to extremity and occupational exposure limits by applying a factor of 2.5 for extremity exposure and a factor of 5 for occupational exposure to the corresponding SAR thresholds.

7. OPERATIONAL CONDITIONS DURING TEST

7.1 SAR TEST CONFIGURATION

For WLAN SAR testing, WLAN engineering testing software installed on the DUT can provide continuous transmitting RF signal.

2.4G

Mode	802.11b	802.11g	802.11n HT20	802.11n HT20
Duty cycle	100%			
Crest factor	1			

5G

Mode	802.11a	802.11n HT20	802.11n HT40	802.11ac HT20	802.11ac HT40	802.11ac VH80
Duty cycle	100%					
Crest factor	1					

For WiFi SAR testing, a communication link is set up with the test mode software for WiFi mode test. During the test, at the each test frequency channel, the EUT is operated at the RF continuous emission mode. The RF signal utilized in SAR measurement has 100% duty cycle and its crest factor is 1. The test procedures in KDB 248227D01v02r02 are applied.

7.1.1 2.4G SAR Test Requirements

◇ 802.11b DSSS SAR Test Requirements

SAR is measured for 2.4 GHz 802.11b DSSS using either a fixed test position or, when applicable, the initial test position procedure. SAR test reduction is determined according to the following:

- 1) When the reported SAR of the highest measured maximum output power channel for the exposure configuration is ≤ 0.8 W/kg, no further SAR testing is required for 802.11b DSSS in that exposure configuration.
- 2) When the reported SAR is > 0.8 W/kg, SAR is required for that exposure configuration using the next highest measured output power channel. When any reported SAR is > 1.2 W/kg, SAR is required for the third channel; i.e., all channels require testing.

◇ 2.4 GHz 802.11g/n OFDM SAR Test Exclusion Requirements

When SAR measurement is required for 2.4 GHz 802.11g/n OFDM configurations, the measurement and test reduction procedures for OFDM are applied. SAR is not required for the following 2.4 GHz OFDM conditions.

- 1) When KDB Publication 447498 SAR test exclusion applies to the OFDM configuration.
- 2) When the highest reported SAR for DSSS is adjusted by the ratio of OFDM to DSSS specified maximum output power and the adjusted SAR is ≤ 1.2 W/kg.

◇ SAR Test Requirements for OFDM configurations

When SAR measurement is required for 2.4 GHz 802.11g/n OFDM configurations, each standalone and frequency aggregated band is considered separately for SAR test reduction. In applying the initial test configuration and subsequent test configuration procedures, the 802.11 transmission configuration with the highest specified maximum output power and the channel within a test configuration with the highest measured maximum output power should be clearly distinguished to apply the procedures.

7.1.2 5G SAR Test Requirements

✧ U-NII-1 and U-NII-2A Band

For devices that operate in both U-NII-1 and U-NII-2A bands, when the same maximum output power is specified for both bands, begin SAR measurement in U-NII-2A band by applying the OFDM SAR requirements. If the highest reported SAR for a test configuration is ≤ 1.2 W/kg, SAR is not required for U-NII-1 band for that configuration (802.11 mode and exposure condition); otherwise, both bands are tested independently for SAR. When different maximum output power is specified for the bands, begin SAR measurement in the band with higher specified maximum output power. The highest reported SAR for the tested configuration is adjusted by the ratio of lower to higher specified maximum output power for the two bands. When the adjusted SAR is ≤ 1.2 W/kg, SAR is not required for the band with lower maximum output power in that test configuration; otherwise, both bands are tested independently for SAR.

✧ U-NII-2C, U-NII-3 Bands

The frequency range covered by these bands is 380 MHz (5.47 – 5.85 GHz), which requires a minimum of at least two SAR probe calibration frequency points to support SAR measurements. When Terminal Doppler Weather Radar (TDWR) restriction applies, the channels at 5.60 – 5.65 GHz in U-NII-2C band must be disabled with acceptable mechanisms and documented in the equipment certification.

Unless band gap channels are permanently disabled, they must be considered for SAR testing. To maintain SAR measurement accuracy and to facilitate test reduction, the channels in U-NII-2C band above 5.65 GHz may be grouped with the 5.8 GHz channels in U-NII-3 or §15.247 band to enable two SAR probe calibration frequency points to cover the bands, including the band gap channels.11 When band gap channels are supported and the bands are not aggregated for SAR testing, band gap channels must be considered independently in each band according to the normally required OFDM SAR measurement and probe calibration frequency points requirements.

7.1.3 OFDM transmission mode and SAR test channel selection

For the 2.4GHz and 5GHz bands, when the same maximum output power was specified for multiple OFDM transmission mode configurations in a frequency band or aggregated band, SAR is measured using the configuration with the largest channel bandwidth, lowest order modulation and lowest data rate. When the maximum output power of a channel is the same for equivalent OFDM configurations (for example 802.11a, 802.11n and 802.11ac, or 802.11g and 802.11n, with the same channel bandwidth, modulation, and data rate, etc.), the lower order 802.11 mode (i.e. 802.11a then 802.11n and 802.11ac, or 802.11g then 802.11n) is used for SAR measurement. When the maximum output power are the same for multiple test channels, either according to the default or additional power measurement requirements, SAR is measured using the channel closest to the middle of the frequency band or aggregated band. When there are multiple channels with the same maximum output power, SAR is measured using the higher number channel.

7.1.4 Initial test configuration procedure

For OFDM, in both 2.4G and 5GHz bands, an initial test configuration is determined for each frequency band and aggregated band, according to the transmission mode with the highest maximum output power specified for SAR measurements. When the same maximum output power is specified for multiple OFDM transmission mode configurations in a frequency band or aggregated band, SAR is measured using the configuration(s) with the largest channel bandwidth, lowest order modulation, and lowest data rate. If the average RF output powers of the highest identical transmission modes are within 0.25 dB of each other, mid channel of the transmission mode with highest average RF output powers is the initial test channel. Otherwise, the channel of the transmission mode with the highest average RF output power will be the initial test configuration.

When the reported SAR is ≤ 0.8 W/kg, no additional measurements on other test channels are required. Otherwise, SAR is evaluated using the subsequent highest average RF output channel until the reported SAR result is ≤ 1.2 W/kg or all channels are measured. When there are multiple untested channels having the same subsequent highest average RF output power, the channel with higher frequency from the lowest 802.11 mode is considered for SAR measurement.

7.2 TEST POSITION OF PORTABLE DEVICES

7.2.1 Head

The device does not have telephone receiver. Next to the ear operation is not supported. Voice mode is limited to speaker mode and headset operations only, so additional Head SAR testing for this type of voice use is not required per KDB616217 D04.

7.2.2 Body

According to section 4.2 of KDB 616217 D04, when antennas are incorporated in the keyboard section of a laptop computer, SAR is required for the bottom surface of the keyboard. SAR tests for bystander exposure from the edges of the keyboard and display screen of laptop computers are generally not required.

Per FCC KDB 447498 D01, the SAR exclusion threshold for distances < 50mm is defined by the following equation:

$$\frac{(\text{max. power of channel, including tune-up tolerance, mW})}{(\text{min. test separation distance, mm})} \sqrt{\text{Frequency (GHz)}} \leq 3.0$$

Based on the maximum conducted power of Bluetooth and the antenna to user separation distance, body Bluetooth SAR is not required;

$$\text{Evaluation}_{(BT)} = [10^{(3/10)} / 5] * (2.480^{1/2}) = 0.63 < 3.0$$

The location of the antenna inside EUT is as below.

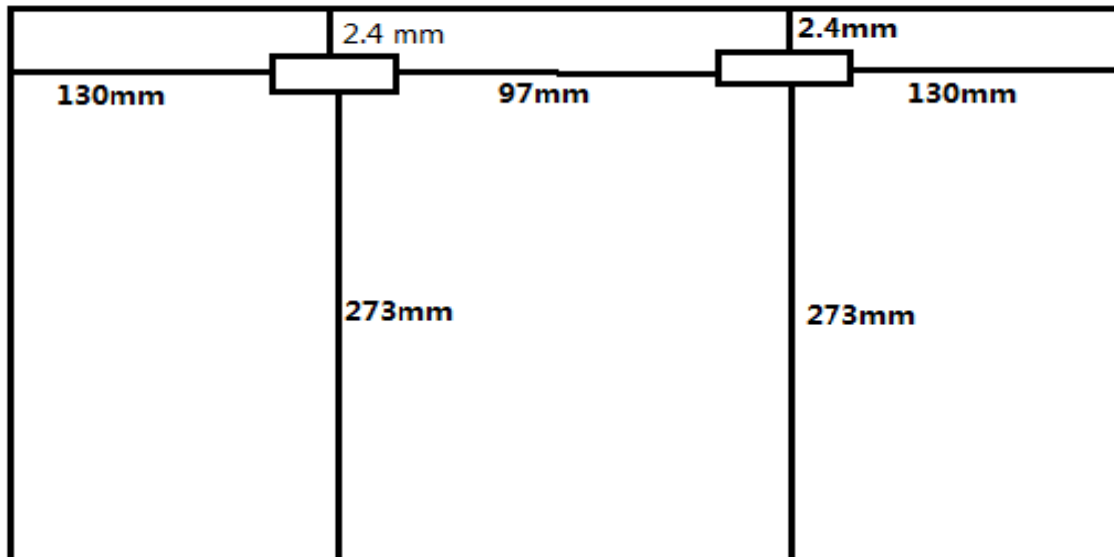

Note: This notebook only supports the MIMO modes.

8. POWER TEST RESULT

8.1 CONDUCTED POWER MEASUREMENTS OF BT

BT	Tune Up	Average Conducted Power (dBm)		
		DH5	2DH5	3DH5
CH0	3.00	2.17	2.61	2.85
CH39	3.00	2.11	2.58	2.82
CH78	3.00	2.10	2.57	2.74

BT	Tune Up	Average Conducted Power (dBm)		
		CH0	CH19	CH39
BT (4.0)	-1.0	-1.43	-1.23	-1.09

Note:

- 1) The conducted power of BT is measured with RMS detector.

8.2 CONDUCTED POWER MEASUREMENTS OF WIFI 2.4G

Mode	Channel	Frequency (MHz)	Data Rate (Mbps)	Tune-up	Average Power (dBm)	SAR Test (Yes/No)
802.11b MIMO	1	2412	2	19.00	18.43	No
	6	2437		19.00	18.34	No
	11	2462		19.00	18.62	Yes
802.11g MIMO	1	2412	12	18.50	18.46	No
	6	2437		18.50	17.74	No
	11	2462		18.50	18.11	No
802.11n HT20 MIMO	1	2412	13	19.00	17.96	No
	6	2437		19.00	18.13	No
	11	2462		19.00	18.71	No
802.11n HT40 MIMO	1	2412	13	16.50	16.27	No
	6	2437		16.50	16.02	No
	11	2462		16.50	16.24	No

Note:

- 1) The Average conducted power of WiFi is measured with RMS detector.
- 2) Per KDB248227, for WiFi 2.4GHz, the highest measured maximum output power Channel for DSSS modes(802.11b)was selected for SAR measurement.SAR for OFDM modes(2.4GHz 802.11g/n) was not required When the highest reported SAR for DSSS is adjusted by the ratio of OFDM modes(802.11g/n)to DSSS modes(802.11b)specified maximum output power and the adjusted SAR is ≤ 1.2 W/kg.

8.3 CONDUCTED POWER MEASUREMENTS OF WIFI 5G

Band	Mode	Channel	Frequency (MHz)	Data Rate (Mbps)	Tune-up	Average Power (dBm)	SAR Test (Yes/No)
5.2G	802.11a MIMO	36	5180	12	19.00	18.67	No
		40	5200		19.00	18.49	No
		44	5220		19.00	18.29	No
		48	5240		19.00	18.11	No
	802.11n HT20 MIMO	36	5180	13	19.00	18.62	No
		40	5200		19.00	18.36	No
		44	5220		19.00	18.19	No
		48	5240		19.00	17.87	No
	802.11n HT40 MIMO	38	5190	27	18.00	17.37	No
		46	5230		18.00	16.95	No
	802.11ac HT20 MIMO	36	5180	13	19.00	18.80	No
		40	5200		19.00	18.66	No
		44	5220		19.00	18.46	No
		48	5240		19.00	18.20	No
	802.11ac HT40 MIMO	38	5190	27	17.50	16.82	No
		46	5230		17.50	17.21	No
802.11ac VH80 MIMO	42	5210	58.6	15.00	14.91	No	

Band	Mode	Channel	Frequency (MHz)	Data Rate (Mbps)	Tune-up	Average Power (dBm)	SAR Test (Yes/No)
5.3G	802.11a MIMO	52	5260	12	19.00	17.98	No
		56	5280		19.00	18.05	No
		60	5300		19.00	17.91	No
		64	5320		19.00	18.50	Yes
	802.11n HT20 MIMO	52	5260	13	19.00	18.30	No
		56	5280		19.00	18.24	No
		60	5300		19.00	18.16	No
		64	5320		19.00	18.03	No
	802.11n HT40 MIMO	54	5270	27	17.00	16.84	No
		62	5310		17.00	16.64	No
	802.11ac HT20 MIMO	52	5180	13	18.00	17.92	No
		56	5200		18.00	17.86	No
		60	5220		18.00	17.76	No
		64	5240		18.00	17.59	No
	802.11ac HT40 MIMO	54	5270	27	17.00	16.90	No
		62	5310		17.00	16.89	No
802.11ac VH80 MIMO	58	5290	58.6	15.00	14.40	No	

Band	Mode	Channel	Frequency (MHz)	Data Rate (Mbps)	Tune-up	Average Power (dBm)	SAR Test (Yes/No)
5.5G	802.11a MIMO	100	5500	12	19.00	18.41	No
		104	5520		19.00	18.37	No
		108	5540		19.00	18.49	No
		112	5560		19.00	18.44	No
		116	5580		19.00	18.65	Yes
		132	5660		19.00	18.56	No
		136	5680		19.00	18.40	No
		140	5700		19.00	18.53	No
	802.11n HT20 MIMO	100	5500	13	19.00	18.81	No
		104	5520		19.00	18.76	No
		108	5540		19.00	18.65	No
		112	5560		19.00	18.69	No
		116	5580		19.00	18.35	No
		132	5660		19.00	18.35	No
		136	5680		19.00	18.28	No
		140	5700		19.00	18.38	No
	802.11n HT40 MIMO	102	5510	27	17.50	17.43	No
		134	5670		17.50	17.08	No
	802.11ac HT20 MIMO	100	5500	13	19.00	18.33	No
		104	5520		19.00	18.30	No
		108	5540		19.00	18.34	No
		112	5560		19.00	18.25	No
		116	5580		19.00	18.72	No
		132	5660		19.00	18.59	No
		136	5680		19.00	18.47	No
		140	5700		19.00	18.49	No
	802.11ac HT40 MIMO	102	5510	27	17.50	17.36	No
		134	5670		17.50	17.30	No
	802.11ac VH80 MIMO	106	5530	58.6	15.50	15.28	No
		138	5690		15.50	14.60	No

Band	Mode	Channel	Frequency (MHz)	Data Rate (Mbps)	Tune-up	Average Power (dBm)	SAR Test (Yes/No)
5.8G	802.11a MIMO	149	5745	12	19.00	18.56	No
		153	5765		19.00	18.50	No
		157	5785		19.00	18.75	Yes
		161	5805		19.00	18.47	No
		165	5825		19.00	18.59	No
	802.11n HT20 MIMO	149	5745	13	19.00	18.04	No
		153	5765		19.00	17.98	No
		157	5785		19.00	18.69	No
		161	5805		19.00	18.16	No
		165	5825		19.00	17.99	No
	802.11n HT40 MIMO	151	5755	27	17.50	17.29	No
		159	5795		17.50	16.92	No
	802.11ac HT20 MIMO	149	5745	13	19.00	18.43	No
		153	5765		19.00	18.42	No
		157	5785		19.00	18.73	No
		161	5805		19.00	18.51	No
		165	5825		19.00	18.33	No
	802.11ac HT40 MIMO	151	5755	27	17.50	17.37	No
		159	5795		17.50	16.98	No
	802.11ac VH80 MIMO	155	5775	58.6	15.00	14.51	No

Note:

1) The Average conducted power of WiFi is measured with RMS detector.

9. SAR TEST RESULTS

General Notes:

- 1) Per KDB447498 D01v06, all measurement SAR results are scaled to the maximum tune-up tolerance limit to demonstrate compliant.
- 2) Per KDB447498 D01v06, testing of other required channels within the operating mode of a frequency band is not required when the reported 1-g or 10-g SAR for the mid-band or highest output power channel is: ≤ 0.8 W/kg or 2.0 W/kg, for 1-g or 10-g respectively, when the transmission band is ≤ 100 MHz. When the maximum output power variation across the required test channels is $> \frac{1}{2}$ dB, instead of the middle channel, the highest output power channel must be used.
- 3) Per KDB865664 D01v01r04, for each frequency band, repeated SAR measurement is required only when the measured SAR is ≥ 0.8 W/Kg; if the deviation among the repeated measurement is $\leq 20\%$, and the measured SAR < 1.45 W/Kg, only one repeated measurement is required.
- 4) Per KDB865664 D02v01r02, SAR plot is only required for the highest measured SAR in each exposure configuration, wireless mode and frequency band combination; Plots are also required when the measured SAR is > 1.5 W/kg, or > 7.0 W/kg for occupational exposure. The published RF exposure KDB procedures may require additional plots; for example, to support SAR to peak location separation ratio test exclusion and/or volume scan post-processing.

WLAN Notes:

- 1) For exposure conditions with multiple test positions, such as handset operating next to the ear, devices with hotspot mode, procedures for initial test position can be applied. Using the transmission mode determined by the DSSS procedure or initial test configuration, area scans are measured for all positions in an exposure condition. The test position with the highest extrapolated(peak)SAR is used as the initial test position. When the reported SAR of the initial test position is ≤ 0.4 W/kg, further SAR measurement is not required for the other (remaining) test positions. Otherwise, SAR is evaluated at the subsequent highest peak SAR position until the reported SAR result is ≤ 0.8 W/kg or all test positions are measured.
- 2) Justification for test configurations for WLAN per KDB Publication 248227 for 2.4GHZ WIFI single transmission chain operations, the highest measured maximum output power Channel for DSSS was selected for SAR measurement.SAR for OFDM modes(2.4GHz 802.11g/n) was not required due to the maximum allowed powers and the highest reported DSSS SAR. See Section 7.1 for more information.
- 3)Justification for test configurations for WLAN per KDB Publication 248227 for 5GHZ WIFI single transmission chain operations, the initial test configuration was selected according to the transmission mode with the highest maximum allowed power. Other transmission modes were not investigated since the highest reported SAR for initial test configuration adjusted by the ratio of maximum output powers is less than 1.2W/kg. See Section 7.1 for more information.

9.1 SAR MEASUREMENT RESULT

Test No.	Band	CH	Test Position	Separation Distance (cm)	Data Rate	Power Setting	Tune up (dBm)	Measured (dBm)	Drift(dB)	Area Scan Peak SAR	SAR Value (W/kg)1-g	Reported SAR
T01	802.11b	11	Bottom Side	0	1	12	19	18.43	0.00	0.129	0.125	0.143
T02	802.11b	11	Rear Face	2.5	1	12	19	18.43	0.00	0.000	0.000	0.000
T03	802.11a	64	Bottom Side	0	6	15	19	18.5	0.00	0.613	0.643	0.721
T04	802.11a	64	Rear Face	2.5	6	15	19	18.5	0.00	0.069	0.042	0.047
T06	802.11a	116	Bottom Side	0	6	13	19	18.65	0.00	0.309	0.349	0.378
T07	802.11a	116	Rear Face	2.5	6	13	19	18.65	0.00	0.008	0.012	0.013
T09	802.11a	157	Bottom Side	0	6	14	19	18.75	0.00	0.401	0.421	0.446
T10	802.11a	157	Rear Face	2.5	6	14	19	18.75	0.00	0.000	0.000	0.000

Note:Per KDB248227D01, the highest SAR measured for the initial test position or initial test configuration should be used to determine SAR test exclusion according to the sum of 1-g SAR and SAR peak to location ratio provisions in KDB 447498. In addition, a test lab may also choose to perform standalone SAR measurements for test positions and 802.11 configurations that are not required by the initial test position or initial test configuration procedures and apply the results to determine simultaneous transmission SAR test exclusion, according to sum of 1-g and SAR peak to location ratio requirements to reduce the number of simultaneous transmission SAR measurements.

10. MULTIPLE TRANSMITTER INFORMATION

The location of the antennas inside Tablet is shown as below picture:

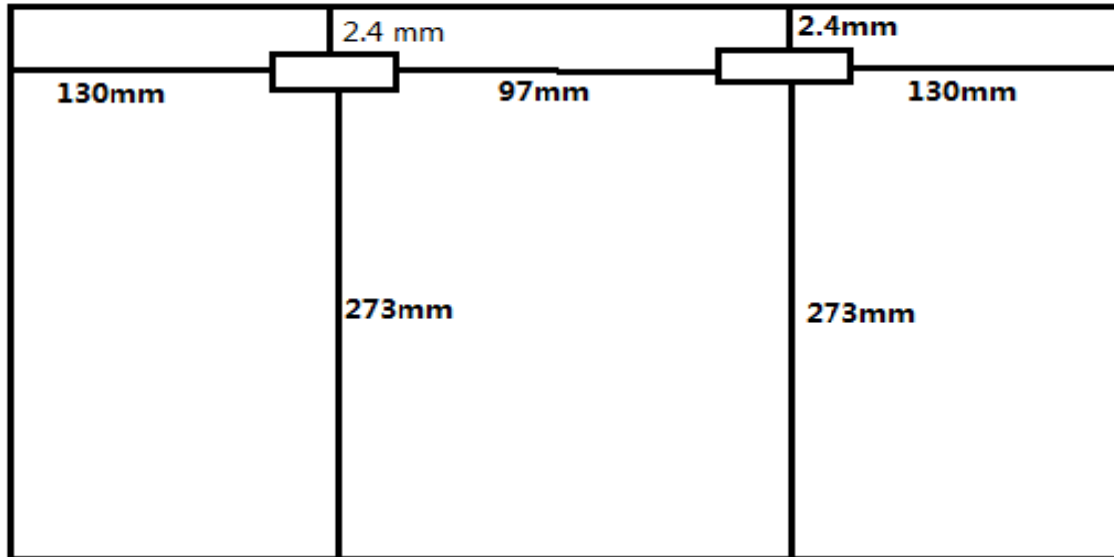

11. SIMULTANEOUS TRANSMISSION CONDITIONS

WiFi antenna and BT antenna cannot transmit simultaneously.

APPENDIX

1. Test Layout

Specific Absorption Rate Test Layout

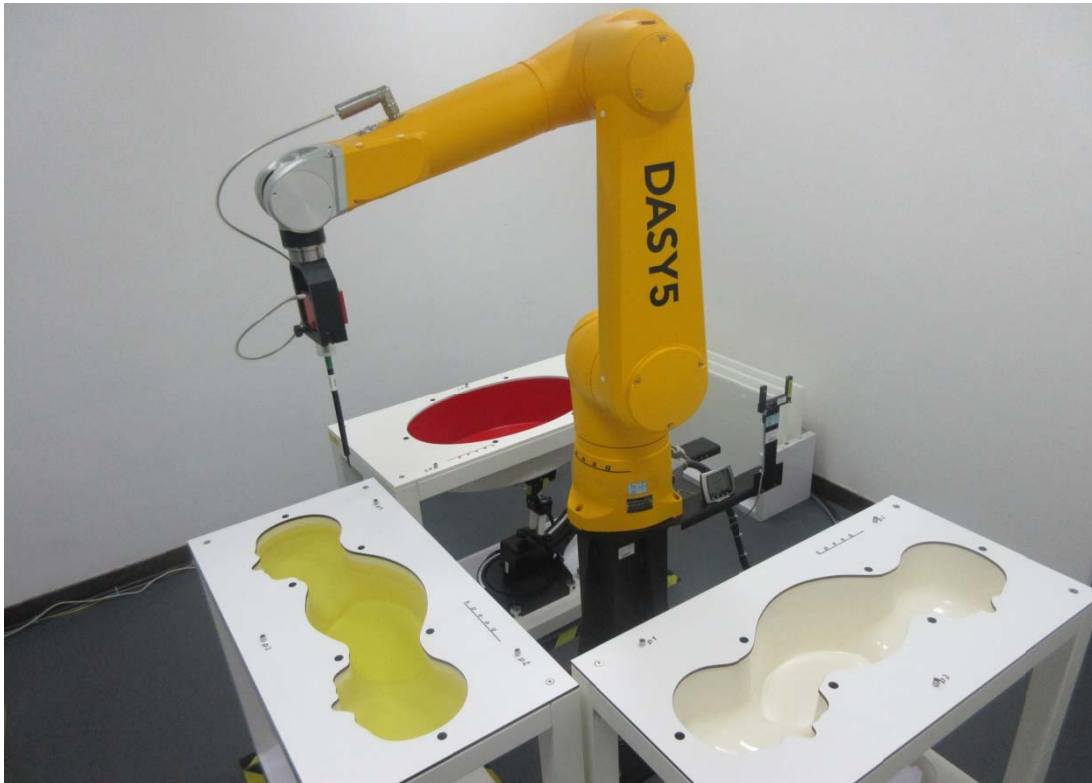

Liquid depth in the flat Phantom ($\geq 15\text{cm}$ depth)

Head 2450MHz 15.8cm

Head 5G 15.2cm

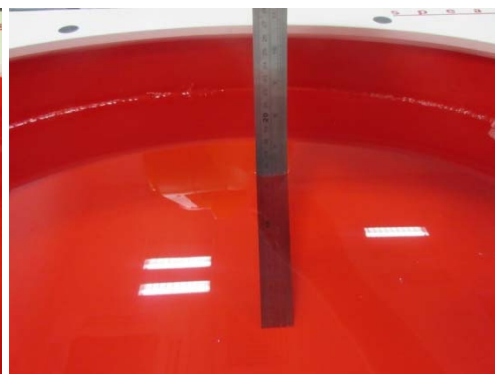
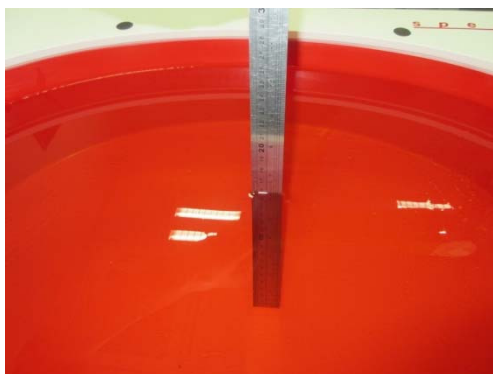

Appendix A. SAR Plots of System Verification

The plots for system verification with largest deviation for each SAR system combination are shown as follows.

Appendix B. SAR Plots of SAR Measurement

The SAR plots for highest measured SAR in each exposure configuration, wireless mode and frequency band combination are shown as follows.

Appendix C. Calibration Certificate for Probe and Dipole

The SPEAG calibration certificates are shown as follows.

Appendix D. Photographs of the Test Set-Up