



# FCC Radio Test Report

## FCC ID: RWO-RZ040379

This report concerns: **Class II Permissive Change**

**Project No.** : 2111C002C  
**Equipment** : Wireless Headset  
**Brand Name** : RAZER  
**Test Model** : RZ04-0379  
**Series Model** : RZ04-0379XXXX-XXXX (X can be 0-9 or A-Z)  
**Applicant** : Razer Inc.  
**Address** : 9 Pasteur, Suite 100, Irvine, CA92618, USA  
**Manufacturer** : RAZER (ASIA-PACIFIC) PTE. LTD.  
**Address** : Razer SEA HQ, 1 One-north Crescent, #02-01, Singapore 138538  
**Factory** : RAZER TECHNOLOGY AND DEVELOPMENT (SHENZHEN) CO., LTD  
**Address** : East Wing, 3rd Floor, Block 2, Phase 1 of Vision Shenzhen Business Park Keji South Road, Hi-Tech Industrial Park, Shenzhen 518057, China  
**Date of Receipt** : Jul. 11, 2024  
**Date of Test** : Jul. 11, 2024 ~ Jul. 23, 2024  
**Issued Date** : Aug. 07, 2024  
**Report Version** : R00  
**Test Sample** : Sample No.: DG2024071172 for radiated emissions, DG2024071171 for output power.  
**Standard(s)** : FCC CFR Title 47, Part 15, Subpart C

The above equipment has been tested and found compliance with the requirement of the relative standards by BTL Inc.

**Prepared by** : Evan Yang  
Evan Yang

**Approved by** : Chay Cai  
Chay Cai

Room 108, Building 2, No.1, Yile Road, Songshan Lake Zone, Dongguan City, Guangdong, People's Republic of China.

Tel: +86-769-8318-3000    Web: [www.newbtl.com](http://www.newbtl.com)    Service mail: [btl\\_qa@newbtl.com](mailto:btl_qa@newbtl.com)

**Declaration**

**BTL** represents to the client that testing is done in accordance with standard procedures as applicable and that test instruments used has been calibrated with standards traceable to international standard(s) and/or national standard(s).

**BTL's** reports apply only to the specific samples tested under conditions. It is manufacture's responsibility to ensure that additional production units of this model are manufactured with the identical electrical and mechanical components. **BTL** assumes no responsibility for the data provided by the customer, any statements, inferences or generalizations drawn by the customer or others from the reports issued by **BTL**.

The report must not be used by the client to claim product certification, approval, or endorsement by A2LA or any agency of the U.S. Government.

This report is the confidential property of the client. As a mutual protection to the clients, the public and ourselves, the test report shall not be reproduced, except in full, without our written approval.

**BTL's** laboratory quality assurance procedures are in compliance with the ISO/IEC 17025: 2017 requirements, and accredited by the conformity assessment authorities listed in this test report.

**BTL** is not responsible for the sampling stage, so the results only apply to the sample as received.

The information, data and test plan are provided by manufacturer which may affect the validity of results, so it is manufacturer's responsibility to ensure that the apparatus meets the essential requirements of applied standards and in all the possible configurations as representative of its intended use.

**Limitation**

For the use of the authority's logo is limited unless the Test Standard(s)/Scope(s)/Item(s) mentioned in this test report is (are) included in the conformity assessment authorities acceptance respective.

Please note that the measurement uncertainty is provided for informational purpose only and are not use in determining the Pass/Fail results.

<b>Table of Contents</b>	<b>Page</b>
<b>REPORT ISSUED HISTORY</b>	<b>5</b>
<b>1 . APPLICABLE STANDARDS</b>	<b>6</b>
<b>2 . SUMMARY OF TEST RESULTS</b>	<b>6</b>
2.1 TEST FACILITY	7
2.2 MEASUREMENT UNCERTAINTY	7
2.3 TEST ENVIRONMENT CONDITIONS	8
<b>3 . GENERAL INFORMATION</b>	<b>9</b>
3.1 GENERAL DESCRIPTION OF EUT	9
3.2 DESCRIPTION OF TEST MODES	11
3.3 PARAMETERS OF TEST SOFTWARE	12
3.4 BLOCK DIAGRAM SHOWING THE CONFIGURATION OF SYSTEM TESTED	13
3.5 SUPPORT UNITS	14
3.6 CUSTOMER INFORMATION DESCRIPTION	14
<b>4 . AC POWER LINE CONDUCTED EMISSIONS</b>	<b>15</b>
4.1 LIMIT	15
4.2 TEST PROCEDURE	15
4.3 DEVIATION FROM TEST STANDARD	15
4.4 TEST SETUP	16
4.5 EUT OPERATING CONDITIONS	16
4.6 TEST RESULTS	16
<b>5 . RADIATED EMISSIONS</b>	<b>17</b>
5.1 LIMIT	17
5.2 TEST PROCEDURE	18
5.3 DEVIATION FROM TEST STANDARD	19
5.4 TEST SETUP	19
5.5 EUT OPERATING CONDITIONS	21
5.6 TEST RESULTS - 30 MHZ TO 1000 MHZ	21
5.7 TEST RESULTS - ABOVE 1000 MHZ	21
<b>6 . MAXIMUM OUTPUT POWER</b>	<b>22</b>
6.1 LIMIT	22
6.2 TEST PROCEDURE	22
6.3 DEVIATION FROM STANDARD	22

**Table of Contents****Page**

<b>6.4 TEST SETUP</b>	<b>22</b>
<b>6.5 EUT OPERATION CONDITIONS</b>	<b>22</b>
<b>6.6 TEST RESULTS</b>	<b>22</b>
<b>7 . MEASUREMENT INSTRUMENTS LIST</b>	<b>23</b>
<b>APPENDIX A - AC POWER LINE CONDUCTED EMISSIONS</b>	<b>25</b>
<b>APPENDIX B - RADIATED EMISSION - 30 MHZ TO 1000 MHZ</b>	<b>28</b>
<b>APPENDIX C - RADIATED EMISSION - ABOVE 1000 MHZ</b>	<b>31</b>
<b>APPENDIX D - MAXIMUM OUTPUT POWER</b>	<b>38</b>

**REPORT ISSUED HISTORY**

Report No.	Version	Description	Issued Date	Note
BTL-FCCP-1-2111C002C	R00	Original Report.	Aug. 07, 2024	Valid

## 1. APPLICABLE STANDARDS

According to the specifications of the manufacturer, the EUT must comply with the requirements of the following standards:

ANSI C63.10-2013

The following reference test guidance is not within the scope of accreditation of A2LA:

KDB 558074 D01 15.247 Meas Guidance v05r02

## 2. SUMMARY OF TEST RESULTS

Test procedures according to the technical standard(s):

FCC CFR Title 47, Part 15, Subpart C				
Standard(s) Section	Test Item	Test Result	Judgment	Remark
15.207	AC Power Line Conducted Emissions	APPENDIX A	PASS	-----
15.247(d) 15.205(a) 15.209(a)	Radiated Emission	APPENDIX B APPENDIX C	PASS	-----
15.247(a)(1)	Maximum Output Power	APPENDIX D	PASS	-----

Note:

- (1) "N/A" denotes test is not applicable to this device.
- (2) The worst cases of AC Power Line Conducted Emissions, radiated emissions above 30MHz and Maximum Output Power have been re-evaluated by sample of FCC ID: RWO-RZ040379, model name: RZ04-0379. It is found that the new data are the worse, so the test data are reissue from the FCC ID: RWO-RZ040379, model name: RZ04-0379.  
Model difference(s):
  - a. Added a new appearance and a crystal oscillator.
  - b. Changed the manufacturer information.
- (3) The other test records and results please refer to the test report number: BTL-FCCP-1-2111C002, issued date is Dec. 09, 2021.  
Which was accredited by A2LA, FCC registration number is 357015, with the scopes of cited standards in this test report.  
This report is only valid conjunction with the above referenced test report.

## 2.1 TEST FACILITY

The test facilities used to collect the test data in this report:

### For Radiated emissions 1GHz to18GHz:

Room 102 & Room 701, Building 3, No.9, Jinshagang 1st Road, Dalang, Dongguan City, Guangdong People's Republic of China.

### For Others:

No.3, Jinshagang 1st Road, Dalang, Dongguan City, Guangdong People's Republic of China.

BTL's Registration Number for FCC: 747969

BTL's Designation Number for FCC: CN1377

## 2.2 MEASUREMENT UNCERTAINTY

ISO/IEC 17025 requires that an estimate of the measurement uncertainties associated with the emissions test results be included in the report. The measurement uncertainties given below are based on a 95.45% confidence level (based on a coverage factor (k=2))

The BTL measurement uncertainty as below table:

### A. AC power line conducted emissions test:

Test Site	Method	Measurement Frequency Range	U,(dB)
DG-C02	CISPR	150kHz ~ 30MHz	2.88

### B. Radiated emissions test:

Test Site	Method	Measurement Frequency Range	Ant. H / V	U,(dB)
DG-CB03 (3m)	CISPR	30MHz ~ 200MHz	V	4.40
		30MHz ~ 200MHz	H	3.62
		200MHz ~ 1,000MHz	V	4.58
		200MHz ~ 1,000MHz	H	3.98

Test Site	Method	Measurement Frequency Range	U,(dB)
DG-CB18 (3m)	CISPR	1GHz ~ 6GHz	4.48
		6GHz ~ 18GHz	3.88

Test Site	Method	Measurement Frequency Range	U,(dB)
DG-CB03 (1m)	CISPR	18 ~ 26.5 GHz	3.36

### C. Other Measurement:

Test Item	Uncertainty
Maximum Output Power	1.3 dB

Note: Unless specifically mentioned, the uncertainty of measurement has not been taken into account to declare the compliance or non-compliance to the specification.

**2.3 TEST ENVIRONMENT CONDITIONS**

Test Item	Temperature	Humidity	Test Voltage	Tested By	Test Date
AC Power Line Conducted Emissions	21°C	40%	AC 120V/60Hz	Hayden Chen	Jul. 16, 2024
Radiated Emissions -30 MHz to 1000 MHz	25°C	60%	DC 5V	Chen Mo	Jul. 15, 2024
Radiated Emissions -Above 1000 MHz	23°C	53%	DC 5V	Jensen Zhou Allen Tong	Jul. 16, 2024
	25°C	53%	DC 5V	Jensen Zhou	Jul. 23, 2024
Maximum Output Power	23°C	59%	DC 5V	Parker Yang	Jul. 17, 2024



### 3. GENERAL INFORMATION

#### 3.1 GENERAL DESCRIPTION OF EUT

Equipment	Wireless Headset
Brand Name	RAZER
Test Model	RZ04-0379
Series Model	RZ04-0379XXXX-XXXX (X can be 0-9 or A-Z)
Model Difference(s)	Only differ in model name.
Software Version	V1.0
Hardware Version	MP
Power Source	1# Supplied from PC USB port. 2# Supplied from battery. Model: 553450PN2
Power Rating	1# DC 5V 2# DC 3.7V 1200mAh/4.44Wh
Operation Frequency	2402 MHz ~ 2480 MHz
Modulation Type	GFSK, $\pi/4$ -DQPSK, 8-DPSK
Bit Rate of Transmitter	1Mbps, 2Mbps, 3Mbps
Max. Peak Output Power	3Mbps: 9.58 dBm (0.0091 W)
Max. Average Output Power	3Mbps: 7.30 dBm (0.0054 W)

Note:

- For a more detailed features description, please refer to the manufacturer's specifications or the user's manual.
- The system model number is RZ04-0379XXXX-XXXX, this system consists of Gaming Headset (Model: RZ04-0379) and USB Wireless Transceiver (Model: RC30-0378), X can be 0-9 or A-Z.

## 3. Channel List:

Channel	Frequency (MHz)	Channel	Frequency (MHz)	Channel	Frequency (MHz)
00	2402	27	2429	54	2456
01	2403	28	2430	55	2457
02	2404	29	2431	56	2458
03	2405	30	2432	57	2459
04	2406	31	2433	58	2460
05	2407	32	2434	59	2461
06	2408	33	2435	60	2462
07	2409	34	2436	61	2463
08	2410	35	2437	62	2464
09	2411	36	2438	63	2465
10	2412	37	2439	64	2466
11	2413	38	2440	65	2467
12	2414	39	2441	66	2468
13	2415	40	2442	67	2469
14	2416	41	2443	68	2470
15	2417	42	2444	69	2471
16	2418	43	2445	70	2472
17	2419	44	2446	71	2473
18	2420	45	2447	72	2474
19	2421	46	2448	73	2475
20	2422	47	2449	74	2476
21	2423	48	2450	75	2477
22	2424	49	2451	76	2478
23	2425	50	2452	77	2479
24	2426	51	2453	78	2480
25	2427	52	2454		
26	2428	53	2455		

## 4. Table for Filed Antenna:

Ant.	Brand	Model Name	Antenna Type	Connector	Gain (dBi)
1	Innovation	N/A	PCB	N/A	4.18

### 3.2 DESCRIPTION OF TEST MODES

The test system was pre-tested based on the consideration of all possible combinations of EUT operation mode.

Pretest Mode	Description
Mode 1	TX Mode_1Mbps Channel 00/39/78
Mode 2	TX Mode_2Mbps Channel 00/39/78
Mode 3	TX Mode_3Mbps Channel 00/39/78
Mode 4	TX Mode_3Mbps Channel 00
Mode 5	TX Mode_1Mbps Channel 00
Mode 6	TX Mode_3Mbps Channel 78

Following mode(s) was (were) found to be the worst case(s) and selected for the final test.

<b>AC power line conducted emissions test</b>	
Final Test Mode	Description
Mode 4	TX Mode_3Mbps Channel 00

<b>Radiated emissions test - 30MHz - 1GHz</b>	
Final Test Mode	Description
Mode 4	TX Mode_3Mbps Channel 00

<b>Radiated emissions test - Above 1GHz</b>	
Final Test Mode	Description
Mode 4	TX Mode_3Mbps Channel 00
Mode 5	TX Mode_1Mbps Channel 00
Mode 6	TX Mode_3Mbps Channel 78

<b>Maximum Output Power</b>	
Final Test Mode	Description
Mode 1	TX Mode_1Mbps Channel 00/39/78
Mode 2	TX Mode_2Mbps Channel 00/39/78
Mode 3	TX Mode_3Mbps Channel 00/39/78

**Note:**

The product supports 2.4G Hopping technology and Bluetooth technology at the same time, and the technology used is similar to that of Bluetooth. The chip and fixed frequency software used at the same time are the same. The difference is that when the product does not work with Bluetooth technology, it needs to be used with a dongle. So only tested one of Bluetooth technology and hopping technology.

### 3.3 PARAMETERS OF TEST SOFTWARE

During testing, channel & power controlling software provided by the customer was used to control the operating channel as well as the output power level.

Test Software Version	AWRDLABV2(1.2.9.7)		
Frequency (MHz)	2402	2441	2480
1Mbps	0x02	0x02	0x02
2Mbps	0x02	0x02	0x02
3Mbps	0x02	0x02	0x02

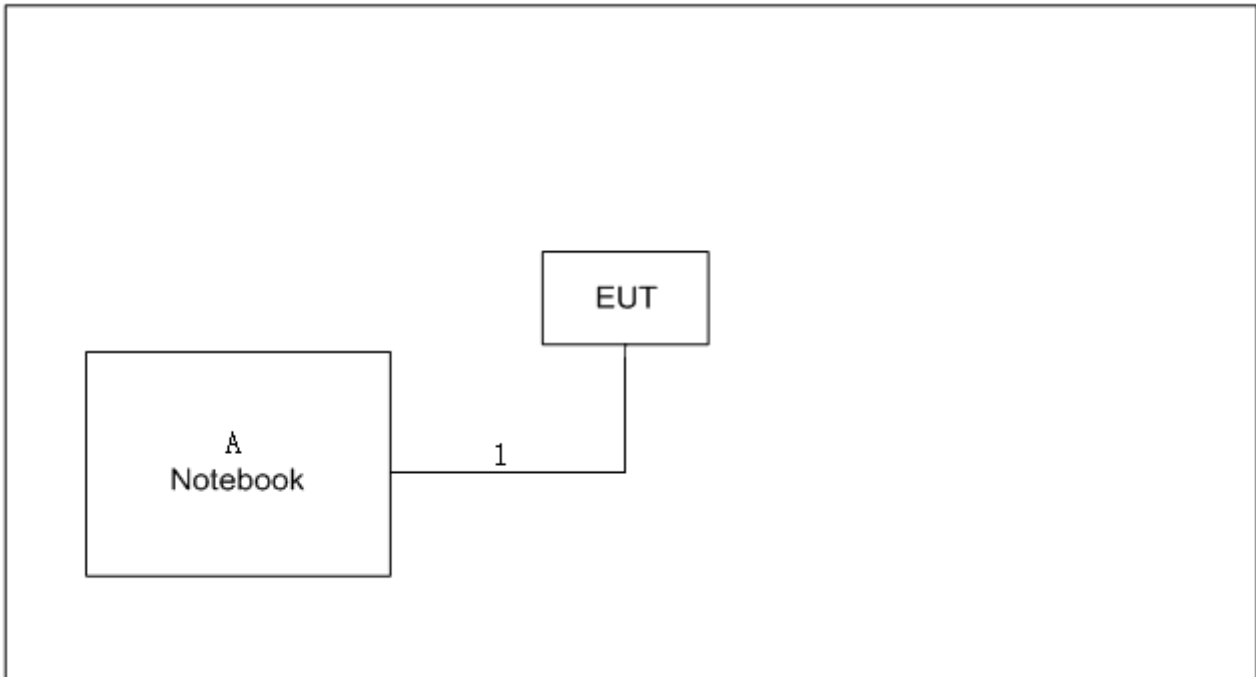
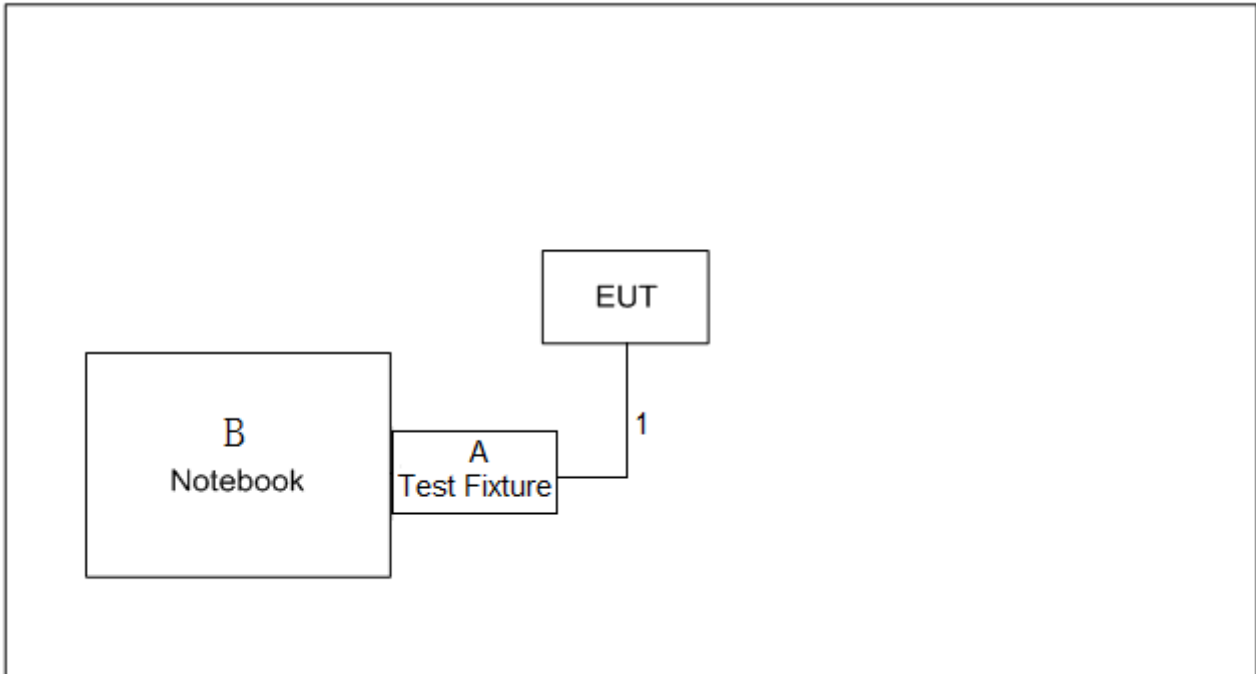
**3.4 BLOCK DIAGRAM SHOWING THE CONFIGURATION OF SYSTEM TESTED****AC power line conducted emissions test****Radiated emissions test**

### 3.5 SUPPORT UNITS

#### AC power line conducted emissions test

Item	Cable Type	Shielded Type	Ferrite Core	Length
A	Notebook	Honor	14SER5 3500	N/A

Item	Cable Type	Shielded Type	Ferrite Core	Length
1	USB Cable	NO	NO	1.2m

#### Radiated emissions test

Item	Cable Type	Shielded Type	Ferrite Core	Length	Note
A	Test Fixture	N/A	N/A	N/A	-
B	Notebook	Lenove	Pro 13	N/A	<b>1GHz to 18GHz</b>
	Notebook	HUAWEI	WFH9	N/A	<b>Above 18GHz</b>

Item	Cable Type	Shielded Type	Ferrite Core	Length
1	Data Cable	NO	NO	0.2m

### 3.6 CUSTOMER INFORMATION DESCRIPTION

- 1) The antenna gain is provided by the manufacturer.
- 2) Except for AC power line conducted emissions and radiated emissions, the results of all test items include cable losses. Part of the cable losses (0.5dB) are provided by the manufacturer, while the other parts of the cable losses are provided by the testing laboratory.

## 4. AC POWER LINE CONDUCTED EMISSIONS

### 4.1 LIMIT

Frequency of Emission (MHz)	Limit (dB $\mu$ V)	
	Quasi-peak	Average
0.15 - 0.5	66 to 56*	56 to 46*
0.5 - 5.0	56	46
5.0 - 30.0	60	50

Note:

- (1) The tighter limit applies at the band edges.
- (2) The limit of " \* " marked band means the limitation decreases linearly with the logarithm of the frequency in the range.

### 4.2 TEST PROCEDURE

- a. The EUT was placed 0.8 meters from the horizontal ground plane with EUT being connected to the power mains through a line impedance stabilization network (LISN). All other support equipment powered from additional LISN(s). The LISN provide 50 Ohm/ 50uH of coupling impedance for the measuring instrument.
- b. Interconnecting cables that hang closer than 40 cm to the ground plane shall be folded back and forth in the center forming a bundle 30 to 40 cm long.
- c. I/O cables that are not connected to a peripheral shall be bundled in the center. The end of the cable may be terminated, if required, using the correct terminating impedance. The overall length shall not exceed 1 m.
- d. LISN at least 80 cm from nearest part of EUT chassis.
- e. For the actual test configuration, please refer to the related Item –EUT Test Photos.

The following table is the setting of the receiver:

Receiver Parameters	Setting
Start Frequency	0.15 MHz
Stop Frequency	30 MHz
IF Bandwidth	9 kHz

### 4.3 DEVIATION FROM TEST STANDARD

No deviation.

#### 4.4 TEST SETUP

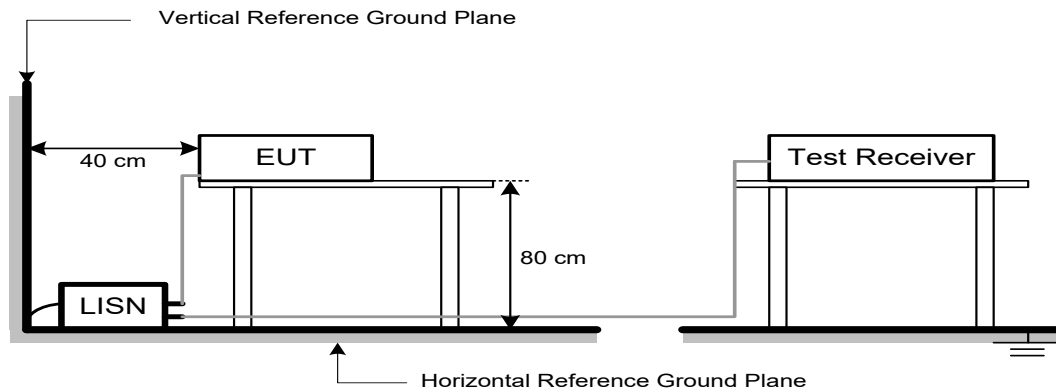

#### 4.5 EUT OPERATING CONDITIONS

The EUT was configured for testing in a typical function (as a customer would normally use it), EUT was programmed to be in continuously transmitting data or hopping on mode.

#### 4.6 TEST RESULTS

Please refer to the APPENDIX A.

Remark:

- (1) All readings are QP Mode value unless otherwise stated AVG in column of [Note] . If the QP Mode Measured value compliance with the QP Limits and lower than AVG Limits, the EUT shall be deemed to meet both QP & AVG Limits and then only QP Mode was measured, but AVG Mode didn't perform in this case, a "\*" marked in AVG Mode column of Interference Voltage Measured.
- (2) Measuring frequency range from 150 kHz to 30 MHz.



## 5. RADIATED EMISSIONS

### 5.1 LIMIT

In case the emission fall within the restricted band specified on 15.205(a), then the 15.209(a) limit in the table below has to be followed.

#### LIMITS OF RADIATED EMISSION MEASUREMENT (30 MHz-1000 MHz)

Frequency (MHz)	Field Strength (microvolts/meter)	Measurement Distance (meters)
30-88	100	3
88-216	150	3
216-960	200	3
Above 960	500	3

#### LIMITS OF RADIATED EMISSION MEASUREMENT (Above 1000 MHz)

Frequency (MHz)	Band edge/ Harmonic at 3m (dB $\mu$ V/m)		Harmonic at 1m (dB $\mu$ V/m)	
	Peak	Average	Peak	Average
Above 1000	74	54	83.5 (Note 4)	63.5 (Note 4)

Note:

- (1) The limit for radiated test was performed according to FCC CFR Title 47, Part 15, Subpart C.
- (2) The tighter limit applies at the band edges.
- (3) Emission level (dB $\mu$ V/m)=20log Emission level (uV/m).
- (4)

$$FS_{\text{limit}} = FS_{\text{max}} - 20 \log \left( \frac{d_{\text{limit}}}{d_{\text{measure}}} \right)$$

$$20 \log (d_{\text{limit}}/d_{\text{measure}}) = 20 \log (3/1) = 9.5 \text{ dB.}$$

## 5.2 TEST PROCEDURE

- a. The measuring distance of 3 m shall be used for measurements. The EUT was placed on the top of a rotating table 0.8 meter above the ground at a 3 meter semi-anechoic chamber. The table was rotated 360 degrees to determine the position of the highest radiation.(below 1 GHz)
- b. The measuring distance of 3 m or 1m shall be used for measurements. The EUT was placed on the top of a rotating table 1.5 meter above the ground at a 3 meter semi-anechoic chamber. The table was rotated 360 degrees to determine the position of the highest radiation.(above 1GHz)
- c. The height of the equipment or of the substitution antenna shall be 0.8m or 1.5m; the height of the test antenna shall vary between 1 m to 4 m. Both horizontal and vertical polarizations of the antenna are set to make the measurement.
- d. For each suspected emission, the EUT was arranged to its worst case and then the antenna was tuned to heights find the maximum reading (used Bore sight function).
- e. The receiver system was set to peak and average detect function and specified bandwidth with maximum hold mode when the test frequency is above 1 GHz.
- f. The initial step in collecting radiated emission data is a receiver peak detector mode pre-scanning the measurement frequency range. Significant peaks are then marked and then Quasi Peak detector mode re-measured.
- g. All readings are Peak unless otherwise stated QP in column of Note. Peak denotes that the Peak reading compliance with the QP Limits and then QP Mode measurement didn't perform.  
(below 1 GHz)
- h. All readings are Peak Mode value unless otherwise stated AVG in column of Note. If the Peak Mode Measured value compliance with the Peak Limits and lower than AVG Limits, the EUT shall be deemed to meet both Peak & AVG Limits and then only Peak Mode was measured, but AVG Mode didn't perform. (above 1 GHz)
- i. For the actual test configuration, please refer to the related Item –EUT Test Photos.

The following table is the setting of the receiver:

Spectrum Parameters	Setting
Start ~ Stop Frequency	30 MHz~1000 MHz for RBW 100 kHz

Spectrum Parameters	Setting
Start Frequency	1000 MHz
Stop Frequency	10th carrier harmonic
RBW / VBW (Emission in restricted band)	1 MHz / 3 MHz for PK value 1 MHz / 1/T Hz for AVG value

Spectrum Parameters	Setting
Start ~ Stop Frequency	30 MHz~1000 MHz for QP detector
Start ~ Stop Frequency	1 GHz~26.5 GHz for PK/AVG detector

### 5.3 DEVIATION FROM TEST STANDARD

No deviation.

### 5.4 TEST SETUP

#### 30 MHz to 1 GHz

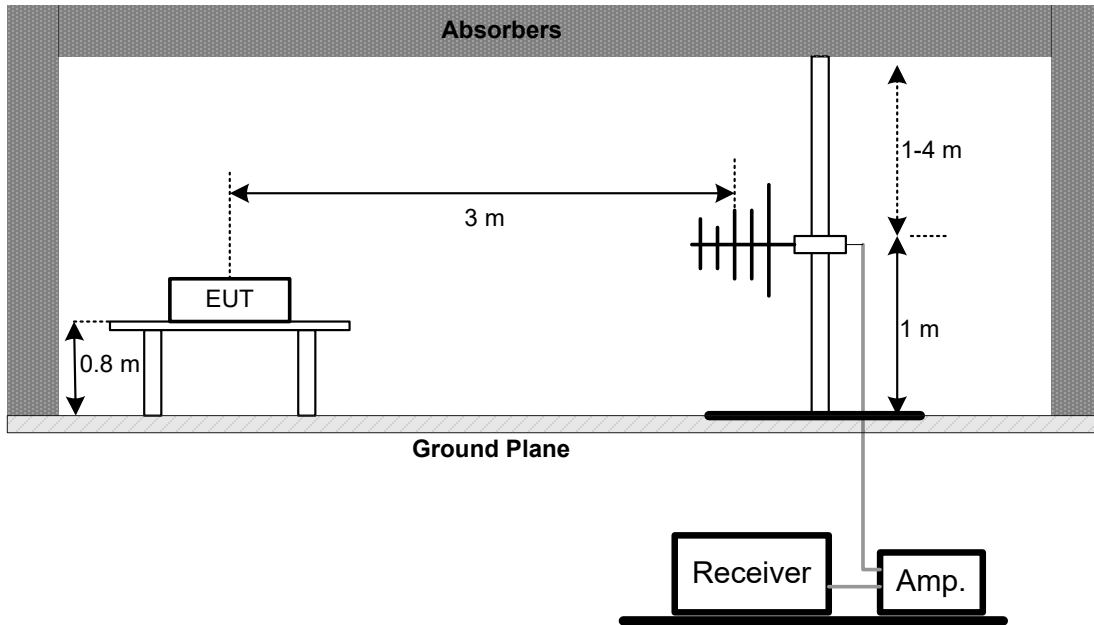

#### Above 1 GHz Band edge

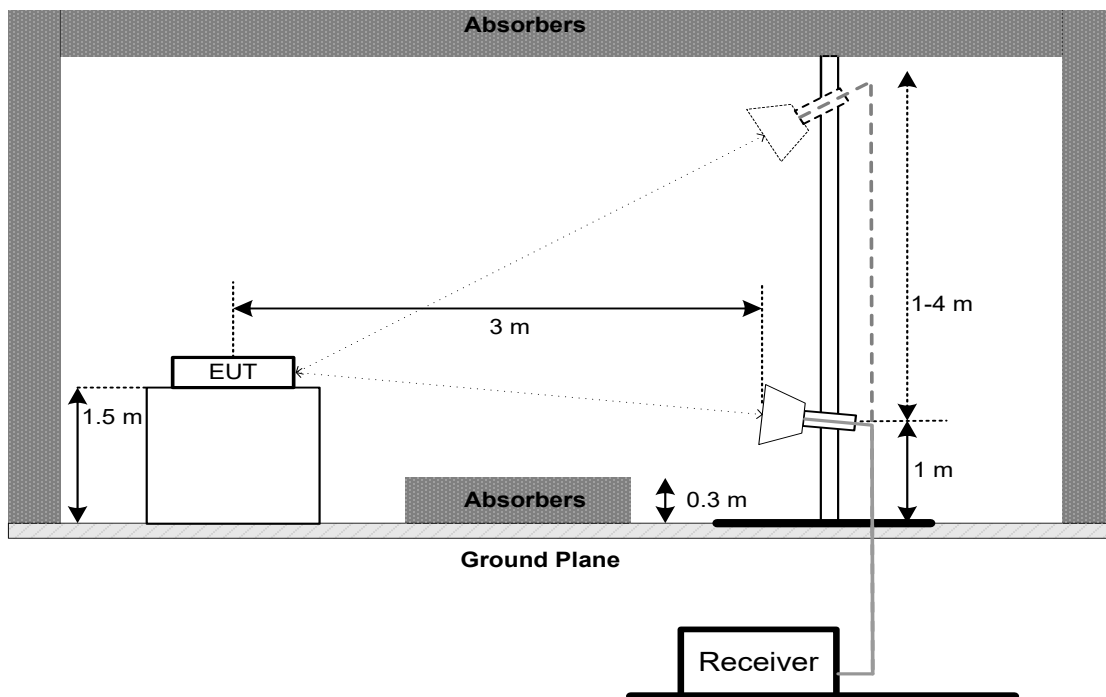

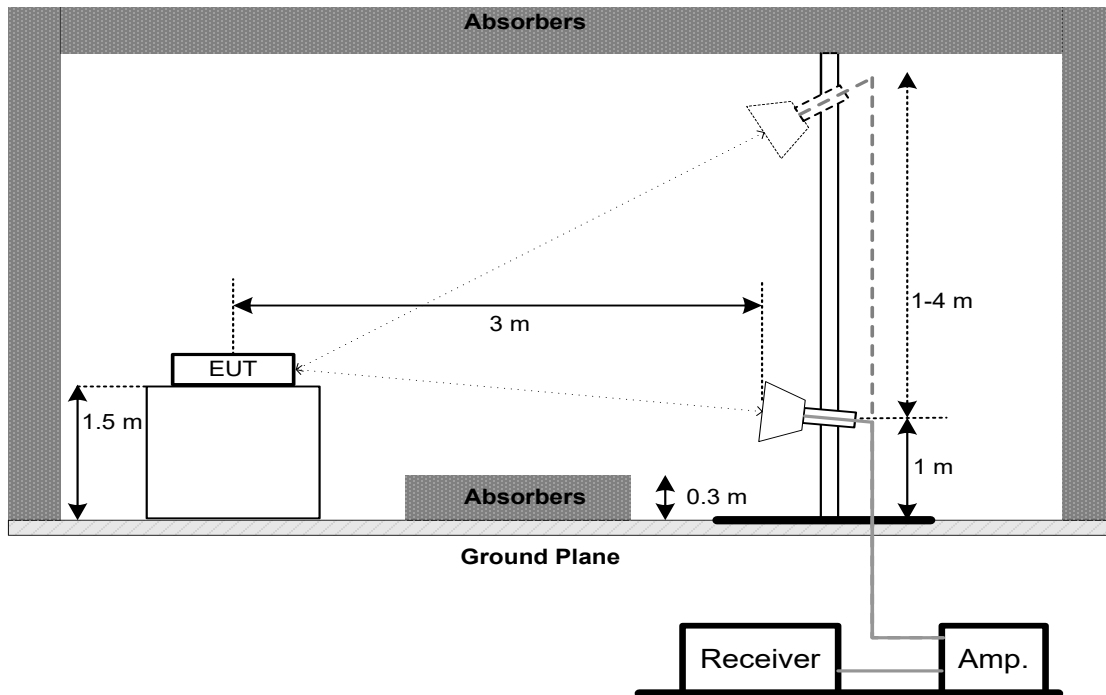
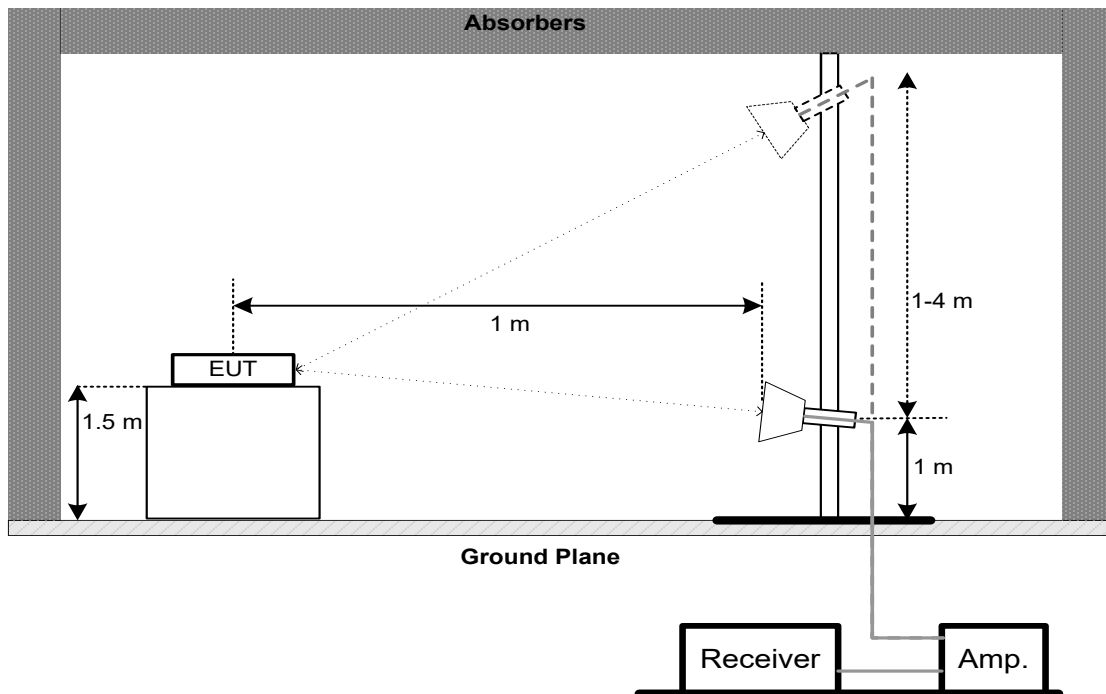
**Harmonic (1 GHz to 18 GHz)****Harmonic (18 GHz to 26.5 GHz)**

**5.5 EUT OPERATING CONDITIONS**

The EUT was programmed to be in continuously transmitting mode.

## Remark:

(1) Distance extrapolation factor =  $40 \log (\text{specific distance} / \text{test distance})$  (dB).

(2) Limit line = specific limits (dBuV) + distance extrapolation factor.

**5.6 TEST RESULTS - 30 MHz TO 1000 MHz**

Please refer to the APPENDIX B.

**5.7 TEST RESULTS - ABOVE 1000 MHz**

Please refer to the APPENDIX C.

## Remark:

(1) No limit: This is fundamental signal, the judgment is not applicable.

For fundamental signal judgment was referred to Peak output test.

## 6. MAXIMUM OUTPUT POWER

### 6.1 LIMIT

Section	Test Item	Limit
FCC 15.247(a)(1)	Maximum Output Power	0.1250 Watt or 20.97 dBm

Note: Frequency hopping systems operating in the 2400-2483.5 MHz band may have hopping channel carrier frequencies that are separated by 25 kHz or two-thirds of the 20 dB bandwidth of the hopping channel, whichever is greater, provided the systems operate with an output power no greater than 125 mW.

### 6.2 TEST PROCEDURE

- a. The EUT was directly connected to the spectrum analyzer and antenna output port as show in the block diagram below.
- b. The following table is the setting of the spectrum analyzer:

Spectrum Parameters	Setting
Span Frequency	Approximately five times the 20 dB bandwidth, centered on a hopping channel.
RBW	3 MHz
VBW	3 MHz
Detector	Peak
Trace	Max Hold
Sweep Time	Auto

### 6.3 DEVIATION FROM STANDARD

No deviation.

### 6.4 TEST SETUP



### 6.5 EUT OPERATION CONDITIONS

The EUT was programmed to be in continuously transmitting mode.

### 6.6 TEST RESULTS

Please refer to the APPENDIX D.

## 7. MEASUREMENT INSTRUMENTS LIST

AC Power Line Conducted Emissions					
Item	Kind of Equipment	Manufacturer	Type No.	Serial No.	Calibrated until
1	EMI TEST RECEIVER	R&S	ESCI	100382	Dec. 22, 2024
2	TWO-LINE V-NETWORK	R&S	ENV216	101447	Dec. 22, 2024
3	Measurement Software	Farad	EZ-EMC Ver.NB-03A1-01	N/A	N/A
4	Cable	N/A	SFT205-NMNM-9M -001	9M	Nov. 27, 2024
5	643 Shield Room	ETS	6*4*3	N/A	N/A

Radiated Emissions - 30 MHz to 1 GHz					
Item	Kind of Equipment	Manufacturer	Type No.	Serial No.	Calibrated until
1	Trilog-Broadband Antenna	Schwarzbeck	VULB 9168	1462	Dec. 13, 2024
2	Attenuator	EMC INSTRUMENT	EMCI-N-6-06	AT-06009	Dec. 13, 2024
3	Preamplifier	EMC INSTRUMENT	EMC001330	980998	Nov. 17, 2024
4	Cable	RegalWay	LMR400-NMNM-12 .5m	N/A	Jun. 06, 2025
5	Cable	RegalWay	LMR400-NMNM-3 m	N/A	Jun. 06, 2025
6	Cable	RegalWay	LMR400-NMNM-0. 5m	N/A	Jun. 06, 2025
7	Receiver	Agilent	N9038A	MY52130039	Dec. 22, 2024
8	Filter	STI	STI15-9923	N/A	May 31, 2025
9	Positioning Controller	MF	MF-7802	N/A	N/A
10	Measurement Software	Farad	EZ-EMC Ver.NB-03A1-01	N/A	N/A
11	966 Chamber room	CM	9*6*6	N/A	May 16, 2025

Radiated Emissions - 1 GHz to 18GHz					
Item	Kind of Equipment	Manufacturer	Type No.	Serial No.	Calibrated until
1	Multi-Device Controller	ETS-Lindgren	N/A	N/A	N/A
2	Measurement Software	Farad	EZ-EMC Ver.NB-03A1-01	N/A	N/A
3	MXA Signal Analyzer	KEYSIGHT	N9020B	MY63380204	Nov. 17, 2024
4	Cable	RegalWay	RWLP50-4.0A-SMS M-1.3M	N/A	Jan. 09, 2025
5	Cable	RegalWay	RWLP50-2.6A-3.5M2 .92MRA-3M	N/A	Jan. 09, 2025
6	Cable	RegalWay	RWLP50-4.0A-SMS M-9M	N/A	Jan. 09, 2025
7	966 Chamber room	ETS	RFD-100(SVSWR)	Q2179	Jan. 09, 2025
8	Preamplifier	EMC INSTRUMENT	EMC118A45SE	981001	May 31, 2025
9	Attenuator	Talent Microwave	TA10A2-S-18	N/A	N/A
10	Filter	STI	STI15-9912	N/A	Nov. 17, 2024
11	Double Ridged Guide Antenna	ETS	3115	75846	Mar. 20, 2025

Radiated Emissions - Above 18 GHz					
Item	Kind of Equipment	Manufacturer	Type No.	Serial No.	Calibrated until
1	MXA Signal Analyzer	KEYSIGHT	N9020B	MY63380204	Nov. 17, 2024
2	Receiver	Agilent	N9038A	MY52130039	Dec. 22, 2024
3	Preamplifier	EMC INSTRUMENT	EMC118A45SE	980888	Nov. 17, 2024
4	EXA Spectrum Analyzer	Keysight	N9010A	MY55150209	May 31, 2025
5	Double Ridged Guide Antenna	ETS	3115	75789	Jun. 15, 2025
6	Cable	RegalWay	RWLP50-4.0A-SMS M-12.5M	N/A	Jul. 03, 2025
7	Cable	RegalWay	RWLP50-4.0A-NM RASM-2.5M	N/A	Jul. 03, 2025
8	Cable	RegalWay	RWLP50-4.0A-NM RASMPA-0.8M	N/A	Jul. 03, 2025
9	Preamplifier	EMC INSTRUMENT	EMC184045SE	980905	Nov. 19, 2024
10	Cable	RegalWay	RWLP50-2.6A-2.92 M2.92M-1.1M	N/A	Jul. 26, 2024
11	Cable	Tonscend	HF160-KMKM-3M	N/A	Jul. 26, 2024
12	Broad-Band Horn Antenna	Schwarzbeck	BBHA9170(3m)	9170-319	Jun. 16, 2025
13	966 Chamber room	CM	9*6*6	N/A	May 19, 2025
14	Positioning Controller	MF	MF-7802	N/A	N/A
15	Measurement Software	Farad	EZ-EMC Ver.NB-03A1-01	N/A	N/A

Maximum Output Power					
Item	Kind of Equipment	Manufacturer	Type No.	Serial No.	Calibrated until
1	Spectrum Analyzer	R&S	FSP40	100185	May 31, 2025
2	Measurement Software	BTL	BTL Conducted Test	N/A	N/A
3	Isolation attenuator	Z-Link	ASMA-16-18-2W	N/A	N/A

Remark "N/A" denotes no model name, serial no. or calibration specified.

All calibration period of equipment list is one year.



## **APPENDIX A - AC POWER LINE CONDUCTED EMISSIONS**

Test Mode	TX 2402 MHz_CH00_3Mbps	Phase	Line
-----------	------------------------	-------	------

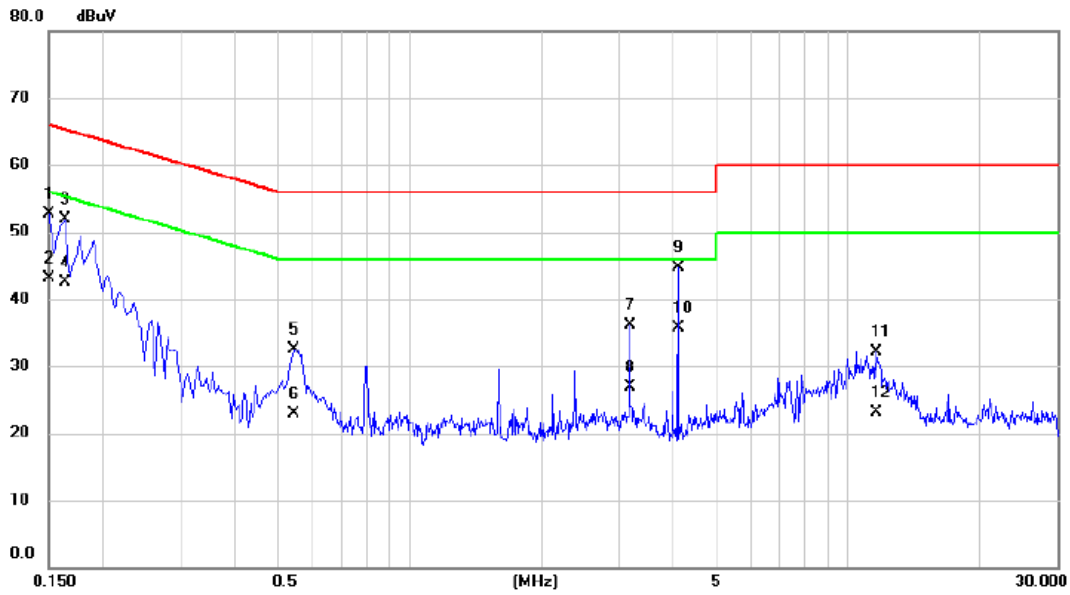

No.	Mk.	Freq. MHz	Reading Level dBuV	Correct Factor dB	Measure- ment dBuV	Limit dBuV	Margin dB	Detector	Comment
1		0.1500	42.78	9.96	52.74	66.00	-13.26	QP	
2		0.1500	33.10	9.96	43.06	56.00	-12.94	AVG	
3		0.1635	41.96	9.97	51.93	65.28	-13.35	QP	
4		0.1635	32.60	9.97	42.57	55.28	-12.71	AVG	
5		0.5460	21.70	10.72	32.42	56.00	-23.58	QP	
6		0.5460	12.20	10.72	22.92	46.00	-23.08	AVG	
7		3.1830	25.66	10.45	36.11	56.00	-19.89	QP	
8		3.1830	16.50	10.45	26.95	46.00	-19.05	AVG	
9		4.0965	34.45	10.32	44.77	56.00	-11.23	QP	
10	*	4.0965	25.40	10.32	35.72	46.00	-10.28	AVG	
11		11.6340	19.84	12.36	32.20	60.00	-27.80	QP	
12		11.6340	10.80	12.36	23.16	50.00	-26.84	AVG	

**REMARKS:**

- (1) Measurement Value = Reading Level + Correct Factor.
- (2) Margin Level = Measurement Value - Limit Value.

Test Mode	TX 2402 MHz_CH00_3Mbps	Phase	Neutral
-----------	------------------------	-------	---------

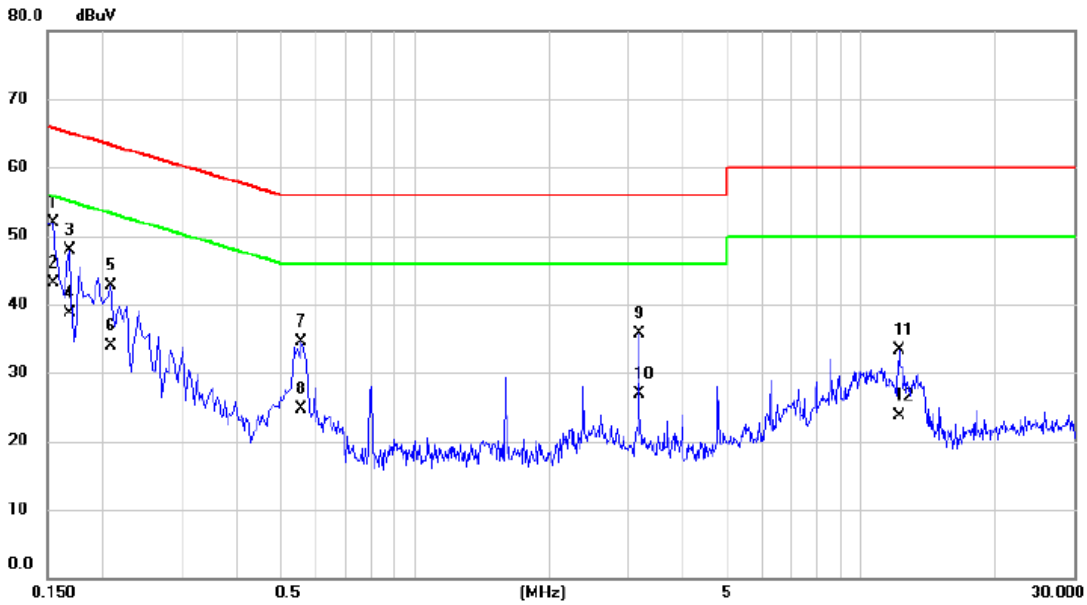

No.	Mk.	Freq. MHz	Reading Level dBuV	Correct Factor dB	Measure- ment dBuV	Limit dBuV	Margin dB	Detector	Comment
1		0.1545	42.02	9.94	51.96	65.75	-13.79	QP	
2	*	0.1545	33.20	9.94	43.14	55.75	-12.61	AVG	
3		0.1680	37.94	9.93	47.87	65.06	-17.19	QP	
4		0.1680	28.70	9.93	38.63	55.06	-16.43	AVG	
5		0.2085	32.82	9.95	42.77	63.26	-20.49	QP	
6		0.2085	23.90	9.95	33.85	53.26	-19.41	AVG	
7		0.5550	23.86	10.70	34.56	56.00	-21.44	QP	
8		0.5550	14.10	10.70	24.80	46.00	-21.20	AVG	
9		3.1830	25.62	10.07	35.69	56.00	-20.31	QP	
10		3.1830	16.90	10.07	26.97	46.00	-19.03	AVG	
11		12.1875	20.88	12.39	33.27	60.00	-26.73	QP	
12		12.1875	11.30	12.39	23.69	50.00	-26.31	AVG	

REMARKS:

- (1) Measurement Value = Reading Level + Correct Factor.
- (2) Margin Level = Measurement Value - Limit Value.

**APPENDIX B - RADIATED EMISSION - 30 MHZ TO 1000 MHZ**

Test Mode	TX 2402 MHz_CH00_3Mbps	Polarization	Vertical
-----------	------------------------	--------------	----------

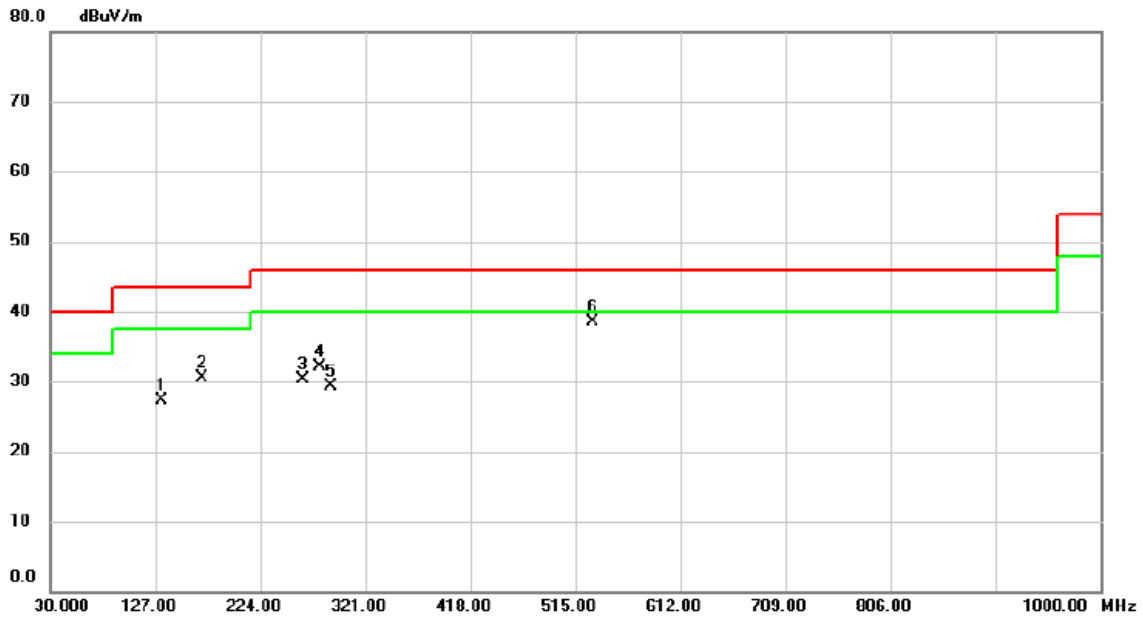

No.	Mk.	Freq. MHz	Reading Level dBuV	Correct Factor dB	Measure- ment dBuV/m	Limit dBuV/m	Margin dB	Detector	Comment
1		133.305	39.38	-12.17	27.21	43.50	-16.29	peak	
2		169.680	41.69	-11.23	30.46	43.50	-13.04	peak	
3		263.285	42.29	-11.89	30.40	46.00	-15.60	peak	
4		278.320	43.30	-11.13	32.17	46.00	-13.83	peak	
5		289.960	39.97	-10.73	29.24	46.00	-16.76	peak	
6	*	530.520	43.84	-5.39	38.45	46.00	-7.55	peak	

**REMARKS:**

- (1) Measurement Value = Reading Level + Correct Factor.
- (2) Margin Level = Measurement Value - Limit Value.

Test Mode	TX 2402 MHz _CH00_3Mbps	Polarization	Horizontal
-----------	-------------------------	--------------	------------

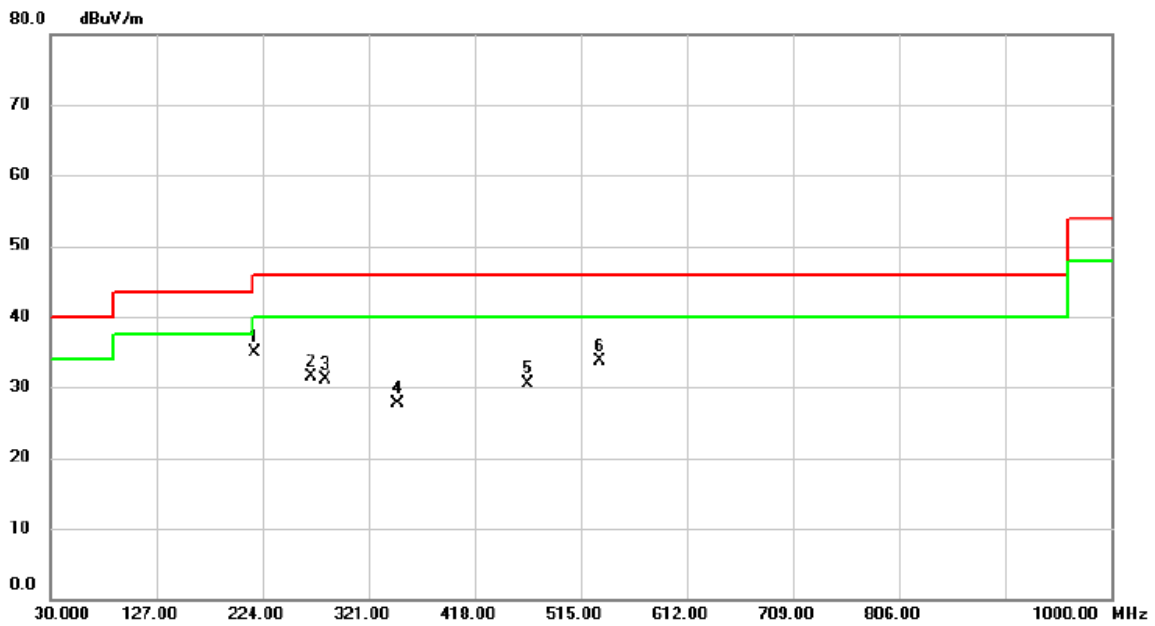

No.	Mk.	Freq. MHz	Reading Level dBuV	Correct Factor dB	Measure- ment dBuV/m	Limit dBuV/m	Margin dB	Detector	Comment
1	*	217.210	49.21	-14.38	34.83	46.00	-11.17	peak	
2		268.620	43.02	-11.58	31.44	46.00	-14.56	peak	
3		281.715	42.00	-10.99	31.01	46.00	-14.99	peak	
4		347.190	37.18	-9.47	27.71	46.00	-18.29	peak	
5		466.500	36.94	-6.53	30.41	46.00	-15.59	peak	
6		531.975	39.13	-5.36	33.77	46.00	-12.23	peak	

**REMARKS:**

(1) Measurement Value = Reading Level + Correct Factor.

(2) Margin Level = Measurement Value - Limit Value.

**APPENDIX C - RADIATED EMISSION - ABOVE 1000 MHZ**

Test Mode	TX 2480 MHz _CH78_3Mbps	Polarization	Vertical
-----------	-------------------------	--------------	----------

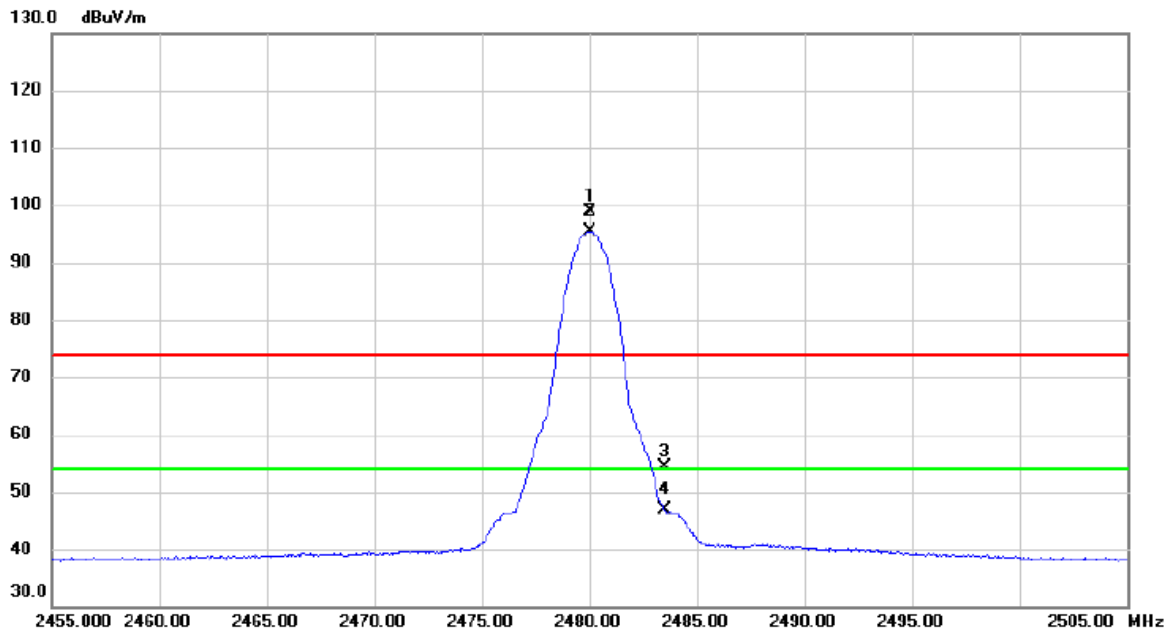

No.	Mk.	Freq. MHz	Reading Level dBuV	Correct Factor dB	Measure- ment dBuV/m	Limit dBuV/m	Margin dB	Detector	Comment
1	X	2480.050	89.43	9.47	98.90	74.00	24.90	peak	No Limit
2	*	2480.050	85.86	9.47	95.33	54.00	41.33	AVG	No Limit
3		2483.500	44.95	9.47	54.42	74.00	-19.58	peak	
4		2483.500	37.33	9.47	46.80	54.00	-7.20	AVG	

**REMARKS:**

- (1) Measurement Value = Reading Level + Correct Factor.
- (2) Margin Level = Measurement Value - Limit Value.



Test Mode	TX 2480 MHz_CH78_3Mbps	Polarization	Horizontal
-----------	------------------------	--------------	------------

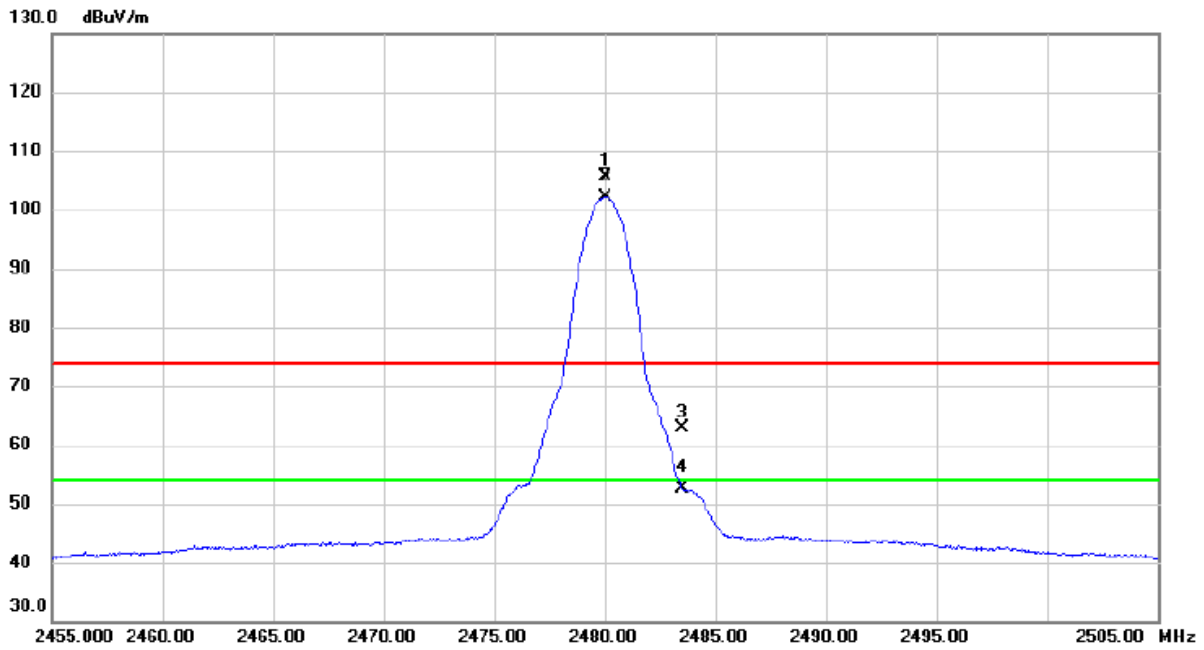

No.	Mk.	Freq. MHz	Reading Level dBuV	Correct Factor dB	Measure- ment dBuV/m	Limit dBuV/m	Margin dB	Detector	Comment
1	X	2480.000	96.13	9.47	105.60	74.00	31.60	peak	No Limit
2	*	2480.000	92.59	9.47	102.06	54.00	48.06	AVG	No Limit
3		2483.500	53.48	9.47	62.95	74.00	-11.05	peak	
4		2483.500	43.27	9.47	52.74	54.00	-1.26	AVG	

**REMARKS:**

- (1) Measurement Value = Reading Level + Correct Factor.
- (2) Margin Level = Measurement Value - Limit Value.

Test Mode	TX 2402 MHz _CH00_1Mbps	Polarization	Vertical
-----------	-------------------------	--------------	----------

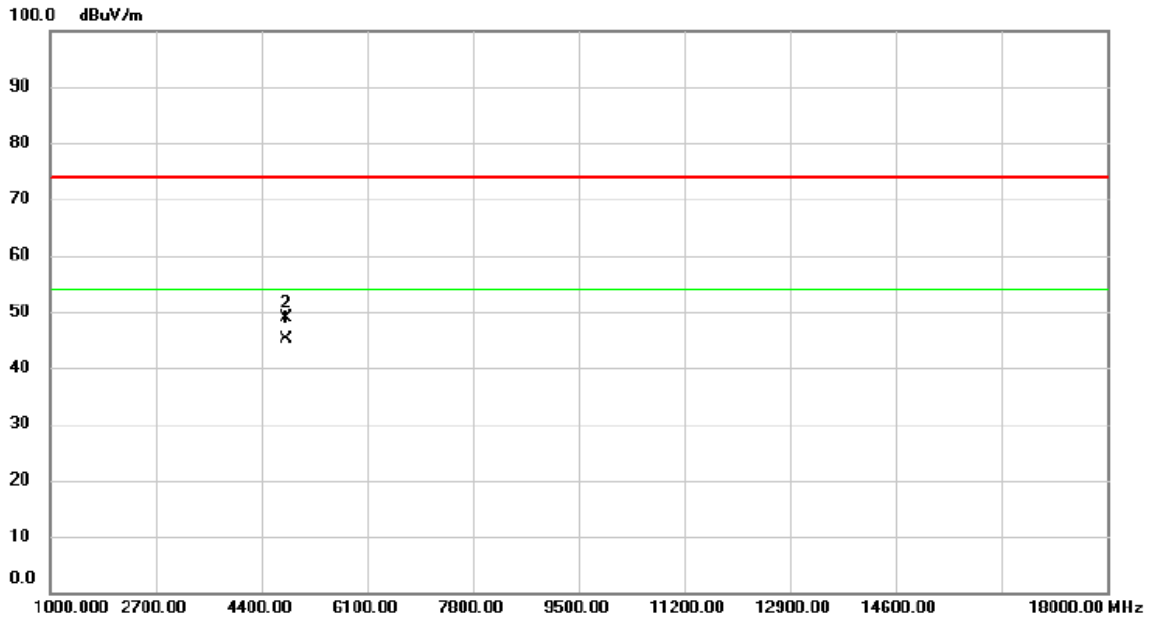

No.	Mk.	Freq. MHz	Reading Level dBuV	Correct Factor dB	Measure- ment dBuV/m	Limit dBuV/m	Margin dB	Detector	Comment
1	*	4804.040	41.31	3.74	45.05	54.00	-8.95	AVG	
2		4804.260	45.25	3.74	48.99	74.00	-25.01	peak	

**REMARKS:**

- (1) Measurement Value = Reading Level + Correct Factor.
- (2) Margin Level = Measurement Value - Limit Value.

Test Mode	TX 2402 MHz_CH00_1Mbps	Polarization	Horizontal
-----------	------------------------	--------------	------------

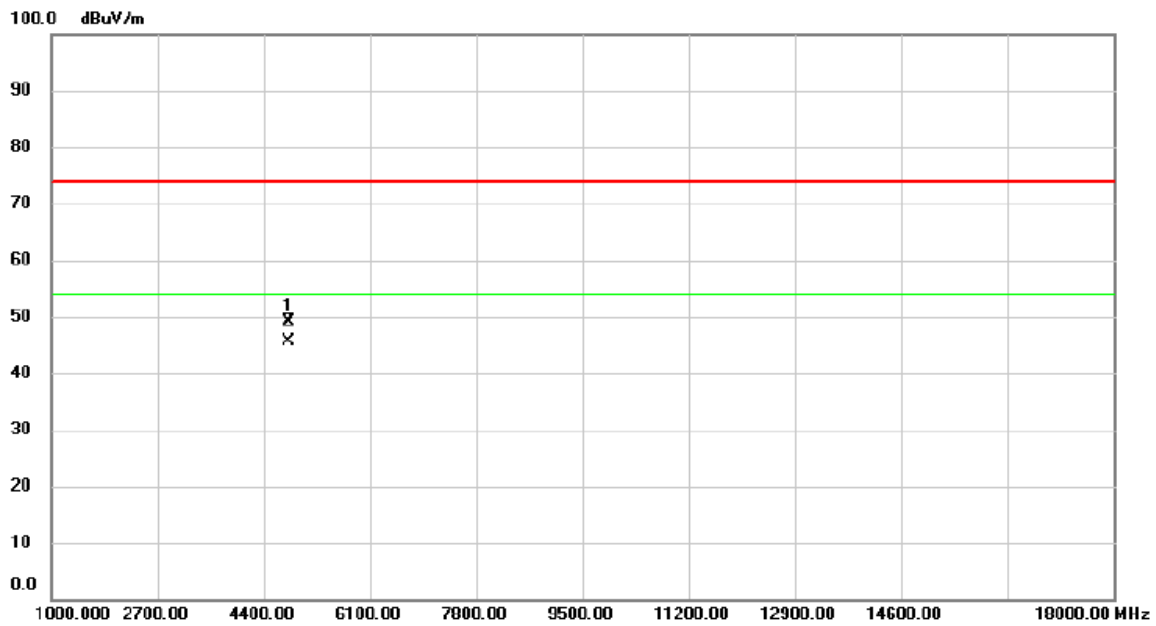

No.	Mk.	Freq.	Reading Level	Correct Factor	Measurement	Limit	Margin	Detector	Comment
		MHz	dBuV	dB	dBuV/m	dBuV/m	dB		
1		4803.910	45.50	3.74	49.24	74.00	-24.76	peak	
2	*	4804.060	41.80	3.74	45.54	54.00	-8.46	AVG	

**REMARKS:**

- (1) Measurement Value = Reading Level + Correct Factor.
- (2) Margin Level = Measurement Value - Limit Value.

Test Mode	TX 2402 MHz _CH00_3Mbps	Polarization	Vertical
-----------	-------------------------	--------------	----------

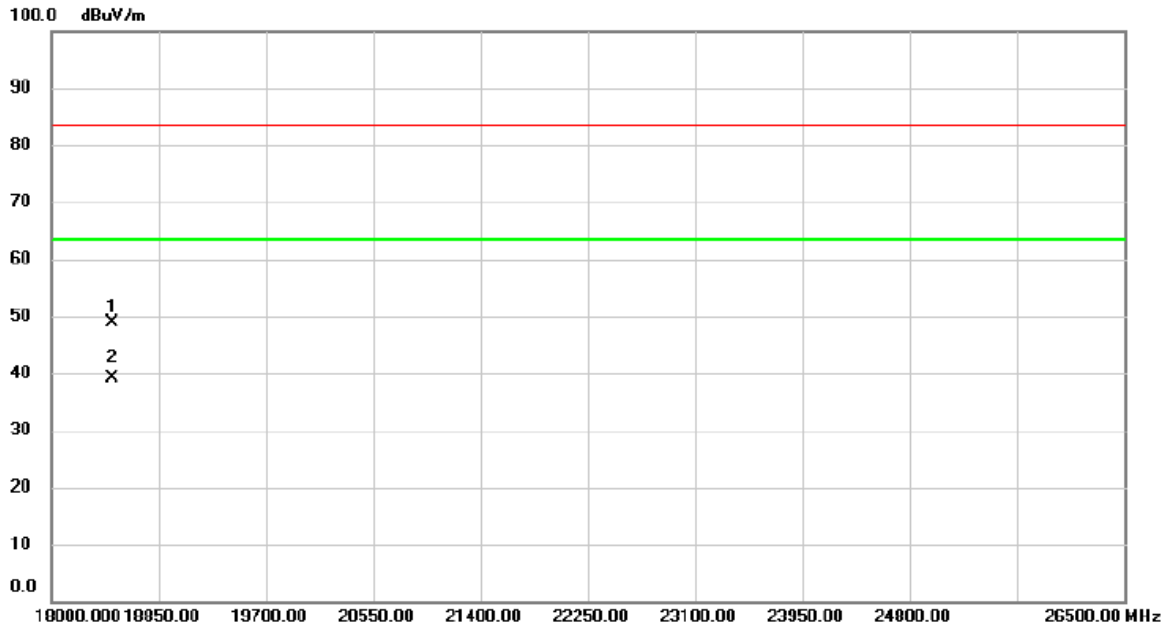

No.	Mk.	Freq. MHz	Reading Level dBuV	Correct Factor dB	Measure- ment dBuV/m	Limit dBuV/m	Margin dB	Detector	Comment
1		18480.250	54.64	-5.66	48.98	83.50	-34.52	peak	
2	*	18480.250	44.77	-5.66	39.11	63.50	-24.39	AVG	

**REMARKS:**

- (1) Measurement Value = Reading Level + Correct Factor.
- (2) Margin Level = Measurement Value - Limit Value.

Test Mode	TX 2402 MHz _CH00_3Mbps	Polarization	Horizontal
-----------	-------------------------	--------------	------------

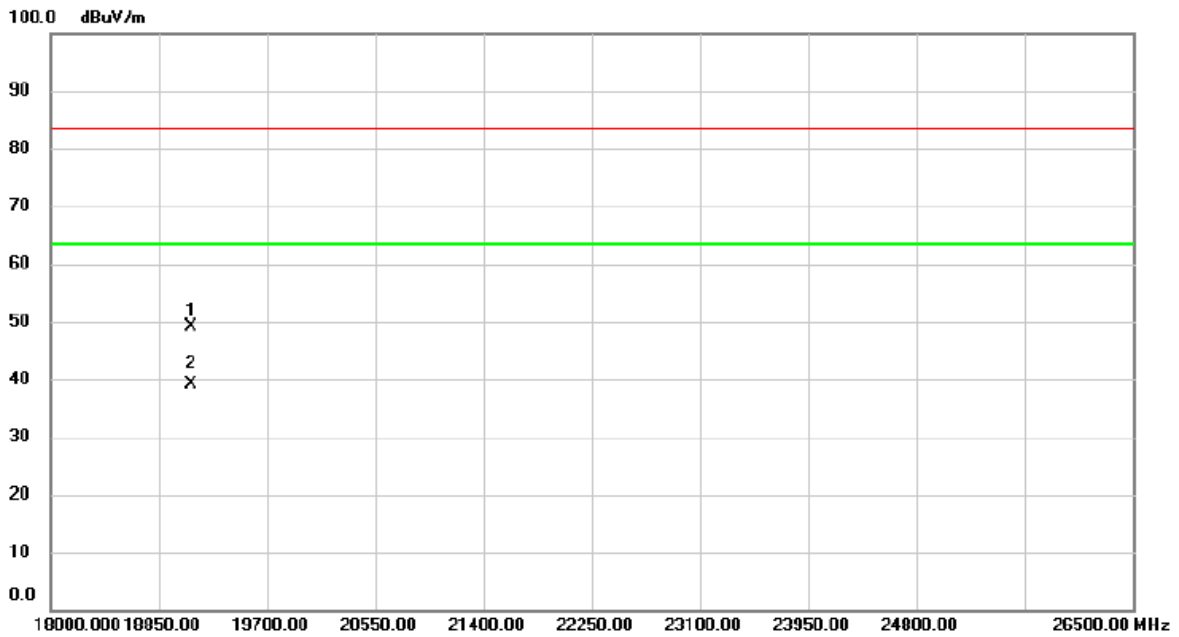

No.	Mk.	Freq. MHz	Reading Level dBuV	Correct Factor dB	Measure- ment dBuV/m	Limit dBuV/m	Margin dB	Detector	Comment
1		19105.000	54.70	-5.58	49.12	83.50	-34.38	peak	
2	*	19105.000	44.66	-5.58	39.08	63.50	-24.42	AVG	

**REMARKS:**

- (1) Measurement Value = Reading Level + Correct Factor.
- (2) Margin Level = Measurement Value - Limit Value.

## **APPENDIX D - MAXIMUM OUTPUT POWER**

Test Mode	TX Mode _ 1Mbps
-----------	-----------------

Channel	Frequency (MHz)	Peak Output Power (dBm)	Max. Limit (dBm)	Max. Limit (W)	Test Result
00	2402	7.26	20.97	0.1250	Pass
39	2441	7.11	20.97	0.1250	Pass
78	2480	7.01	20.97	0.1250	Pass

Channel	Frequency (MHz)	Average Output Power (dBm)	Max. Limit (dBm)	Max. Limit (W)	Test Result
00	2402	7.16	20.97	0.1250	Pass
39	2441	6.97	20.97	0.1250	Pass
78	2480	6.90	20.97	0.1250	Pass

Note: Output power = Measure result + Cable loss

**CH00**

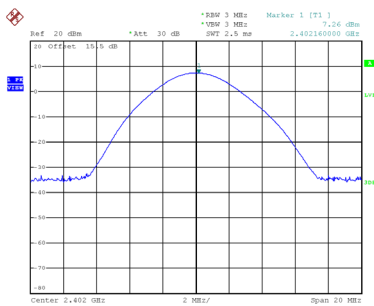

Date: 17\_JUL\_2024 09:52:09

**CH39**  
**Peak Output Power**

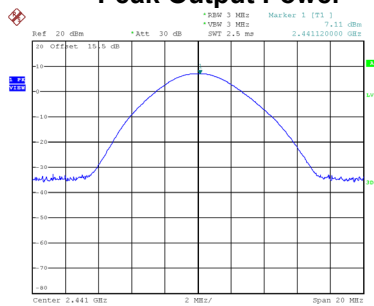

Date: 17\_JUL\_2024 09:52:25

**CH78**

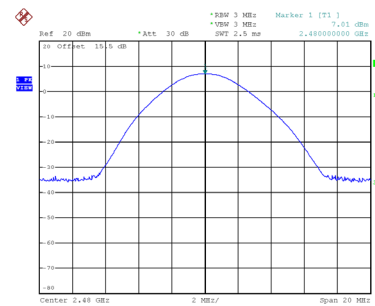

Date: 17\_JUL\_2024 09:52:41

**Average Output Power**

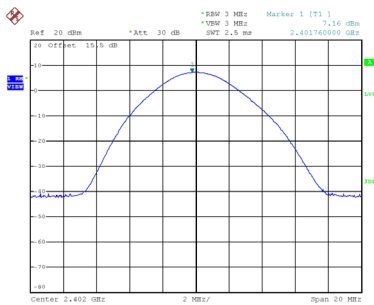

Date: 17\_JUL\_2024 09:59:00

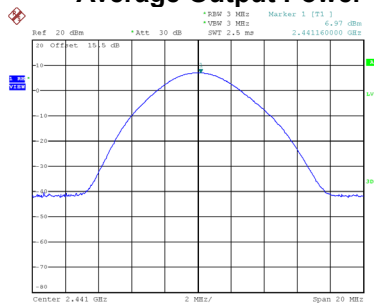

Date: 17\_JUL\_2024 09:59:20

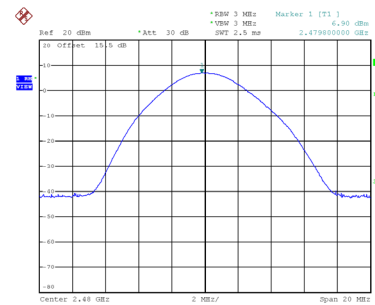

Date: 17\_JUL\_2024 09:59:49

Test Mode	TX Mode _2Mbps
-----------	----------------

Channel	Frequency (MHz)	Peak Output Power (dBm)	Max. Limit (dBm)	Max. Limit (W)	Test Result
00	2402	9.22	20.97	0.1250	Pass
39	2441	9.06	20.97	0.1250	Pass
78	2480	9.03	20.97	0.1250	Pass

Channel	Frequency (MHz)	Average Output Power (dBm)	Max. Limit (dBm)	Max. Limit (W)	Test Result
00	2402	7.29	20.97	0.1250	Pass
39	2441	7.20	20.97	0.1250	Pass
78	2480	7.25	20.97	0.1250	Pass

Note: Output power = Measure result + Cable loss

**CH00**

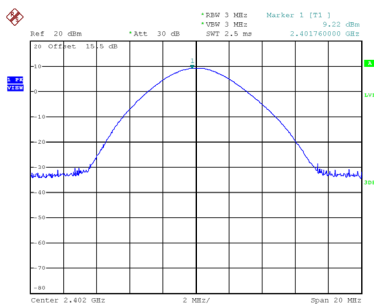

Date: 17\_JUL\_2024 09:53:25

**CH39**  
**Peak Output Power**

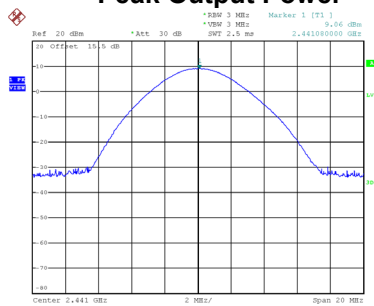

Date: 17\_JUL\_2024 09:53:41

**CH78**

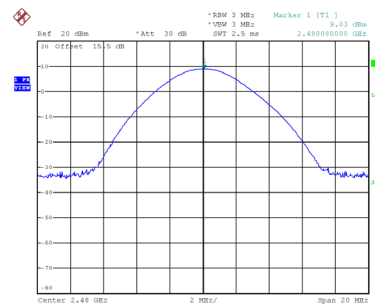

Date: 17\_JUL\_2024 09:53:55

**Average Output Power**

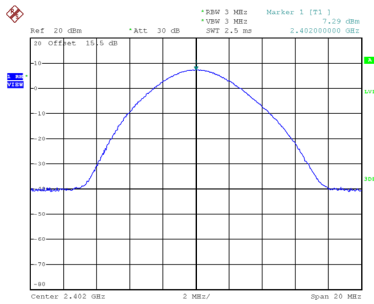

Date: 17\_JUL\_2024 09:57:35

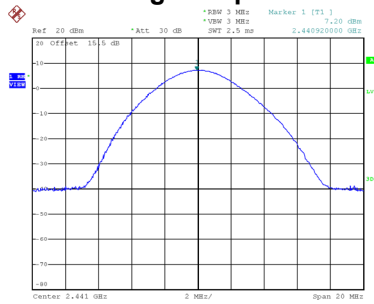

Date: 17\_JUL\_2024 09:57:51

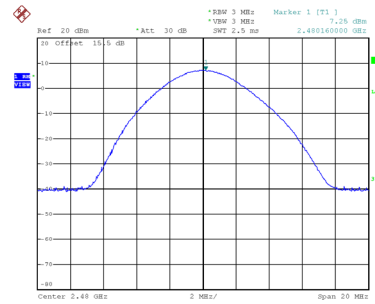

Date: 17\_JUL\_2024 09:58:09



Test Mode	TX Mode_3Mbps
-----------	---------------

Channel	Frequency (MHz)	Peak Output Power (dBm)	Max. Limit (dBm)	Max. Limit (W)	Test Result
00	2402	9.58	20.97	0.1250	Pass
39	2441	9.46	20.97	0.1250	Pass
78	2480	9.37	20.97	0.1250	Pass

Channel	Frequency (MHz)	Average Output Power (dBm)	Max. Limit (dBm)	Max. Limit (W)	Test Result
00	2402	7.30	20.97	0.1250	Pass
39	2441	7.26	20.97	0.1250	Pass
78	2480	7.26	20.97	0.1250	Pass

Note: Output power = Measure result + Cable loss

**CH00**

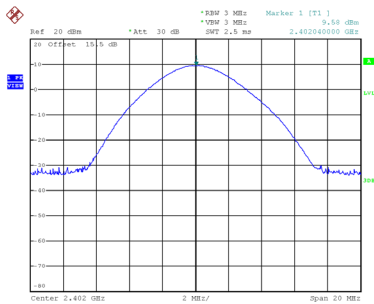

Date: 17\_JUL\_2024 09:54:42

**CH39**  
**Peak Output Power**

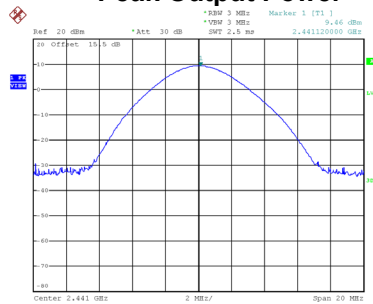

Date: 17\_JUL\_2024 09:55:01

**CH78**

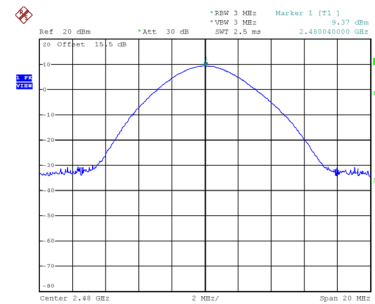

Date: 17\_JUL\_2024 09:55:19

**Average Output Power**

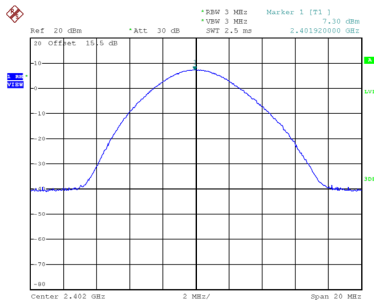

Date: 17\_JUL\_2024 09:56:00

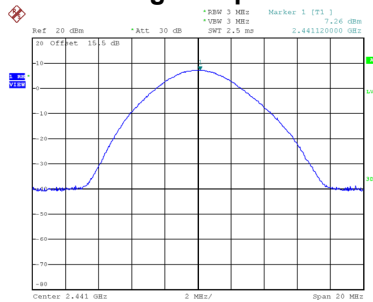

Date: 17\_JUL\_2024 09:56:23

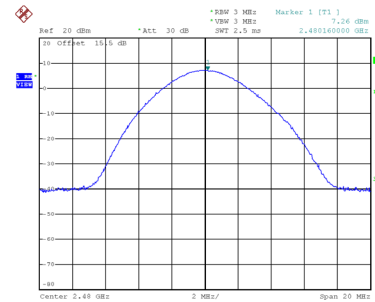

Date: 17\_JUL\_2024 09:56:39

**End of Test Report**