

Dat: 03 Sep 2021

# Product Manual for USB Wireless Transceiver

Model: RC30-026902

## WHAT'S INSIDE / WHAT'S NEEDED

### WHAT'S INSIDE

- Gaming Headset (Model: RZ04-0322)

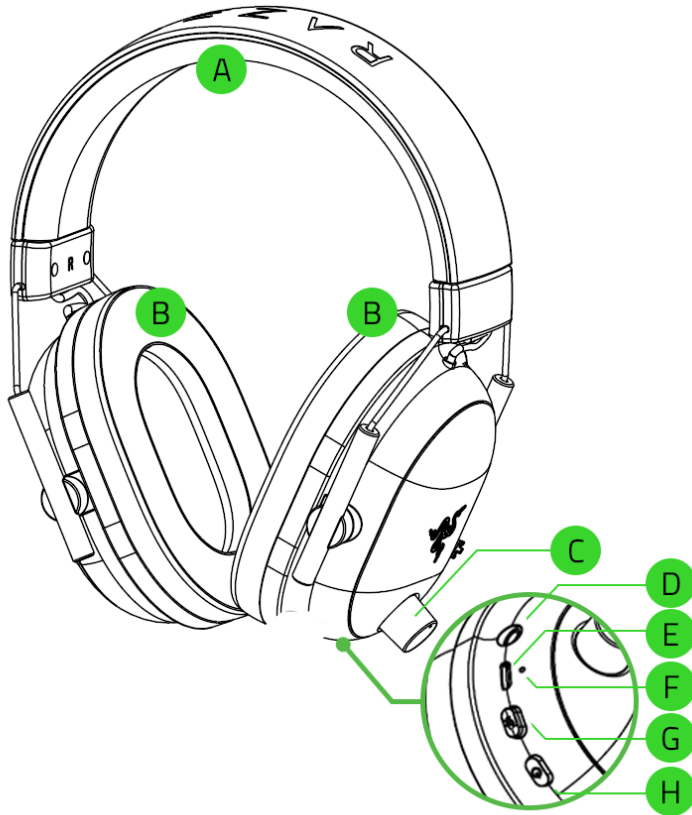

- A. Adjustable padded headband
- B. Ultra-soft breathable memory foam ear cushions
- C. Volume knob
- D. 3.5 mm audio + mic jack
- E. Charging port
- F. Status indicator
- G. Mic mute button
- H. Power button

- Removable Razer™ HyperClear Supercardioid Mic

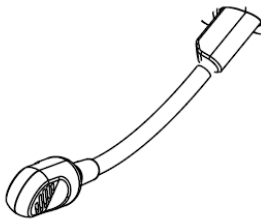

- USB wireless transceiver (RC30-026902)



- Charging cable
- 3.5 mm combo cable

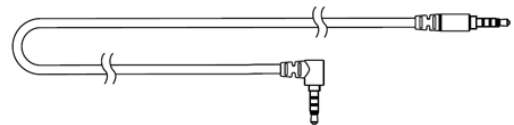

- Important Product Information Guide

## WHAT'S NEEDED

### PRODUCT REQUIREMENTS

- PC with a free USB port
- Devices with 3.5 mm combo jack\*

### RAZER SYNAPSE REQUIREMENTS

- Windows® 7 64-bit (or higher)
- Internet connection for software installation

*\*Compatible with PC / Mac / Switch / PS4 / Xbox One (Xbox One Stereo Adapter may be required, purchased separately).*

---

## LET'S GET YOU COVERED

You've got a great device in your hands, complete with a 2-year limited warranty coverage. Now maximize its potential and score exclusive Razer benefits by registering at [razerid.razer.com](https://razerid.razer.com)

*Your product's serial  
number can be found here.*

Got a question? Ask the Razer Support Team at [support.razer.com](https://support.razer.com)

### Canada Statement

This device contains licence-exempt transmitter(s)/receiver(s) that comply with Innovation, Science and Economic Development Canada's licence-exempt RSS(s).

Operation is subject to the following two conditions:

- (1) This device may not cause interference.
- (2) This device must accept any interference, including interference that may cause undesired operation of the device.

L' émetteur/récepteur exempt de licence contenu dans le présent appareil est conforme aux CNR d' Innovation, Sciences et Développement économique Canada applicables aux appareils radio exempts de licence. L' exploitation est autorisée aux deux conditions suivantes :

- 1) L' appareil ne doit pas produire de brouillage;
- 2) L' appareil doit accepter tout brouillage radioélectrique subi, même si le brouillage est susceptible d' en compromettre le fonctionnement.

The device meets the exemption from the routine evaluation limits in section 2.5 of RSS 102 and compliance with RSS-102 RF exposure, users can obtain Canadian information on RF exposure and compliance.

Le dispositif rencontre l' exemption des limites courantes d' évaluation dans la section 2.5 de RSS 102 et la conformité à l' exposition de RSS-102 rf, utilisateurs peut obtenir l' information canadienne sur l' exposition et la conformité de rf.

---

## GETTING STARTED

### CHARGING YOUR HEADSET



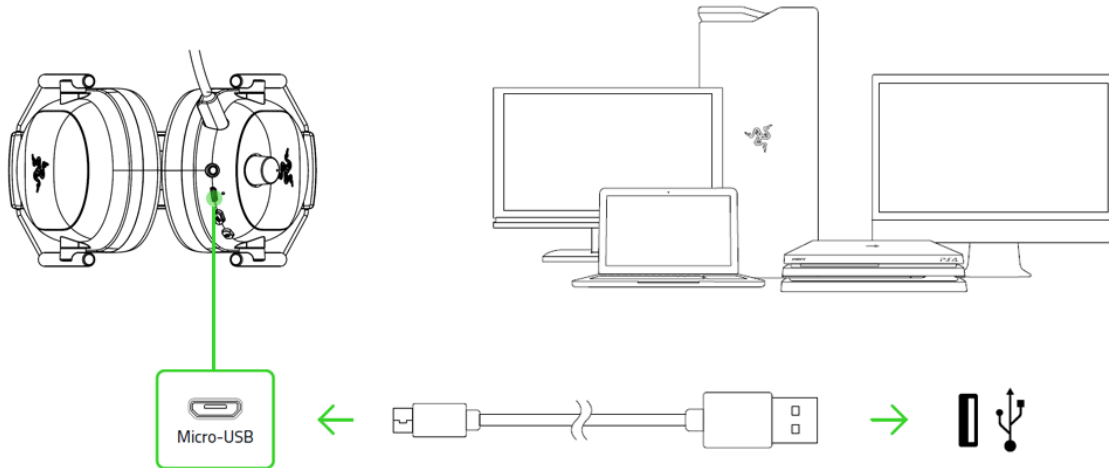

Connect your Razer BlackShark V2 Pro to a powered USB port using the charging cable.











For best results, please fully charge your headset before using it for the first time. A depleted unit will fully charge in about 3 hours.

### STATUS INDICATOR BEHAVIORS

#### When plugged in

Indicator	Battery Status
Blinking green 	Charging 
Static green 	Fully charged 

#### When unplugged

Indicator	Sound	Battery Status
Static green 	None 	Fully charged 
Slow blinking red 	Warning tone 	Low (30%) 
Rapid blinking red 	Warning tone 	Critical(10%) 

# CONNECTING YOUR HEADSET

## A. TO YOUR PC VIA USB PORT

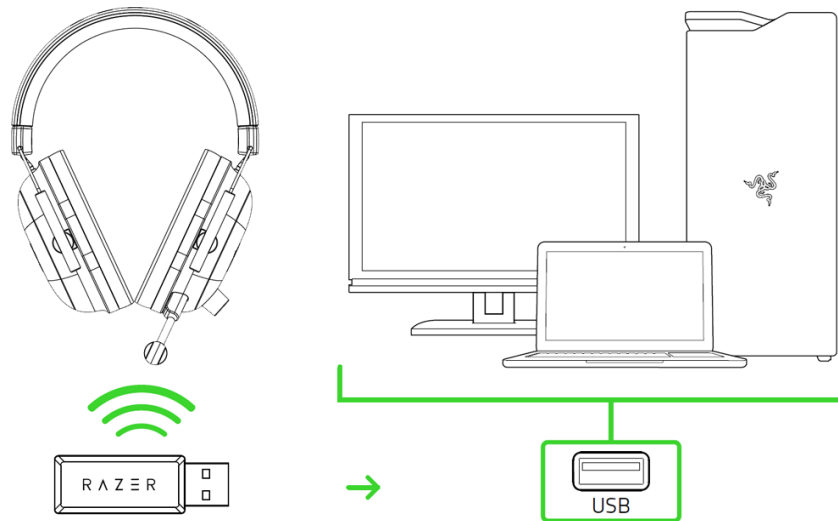

1. Plug the USB wireless transceiver to your PC.

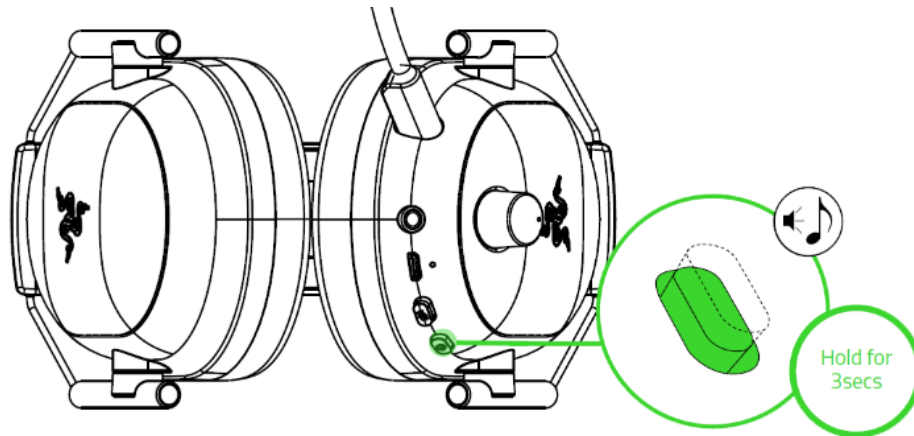

2. Press and hold the power button until the status indicator is lit, or until you hear a tone.



3. Wait until the status indicator briefly becomes static blue indicating that the headset is now connected to the USB wireless transceiver.

Indicator	Status
Blinking blue 	Pairing
Static blue 	Connected

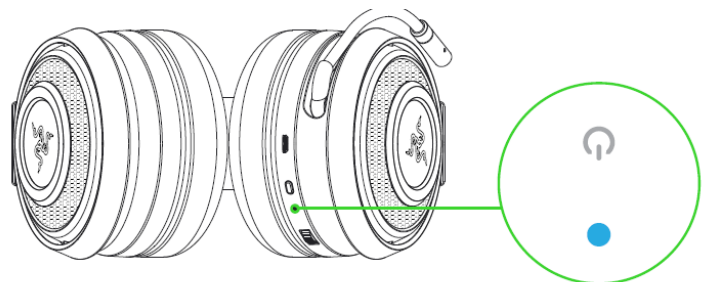

4. On your PC, right-click on the sound icon on the system tray, and then select **Sounds**.

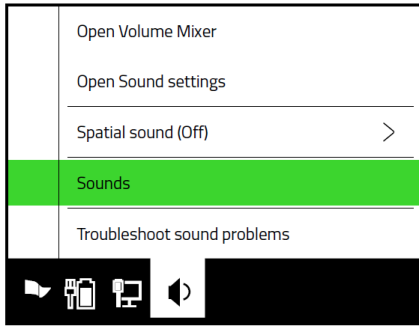

5. On the **Playback** and **Recording** tabs, set **Razer BlackShark V2 Pro** as the Default Device.

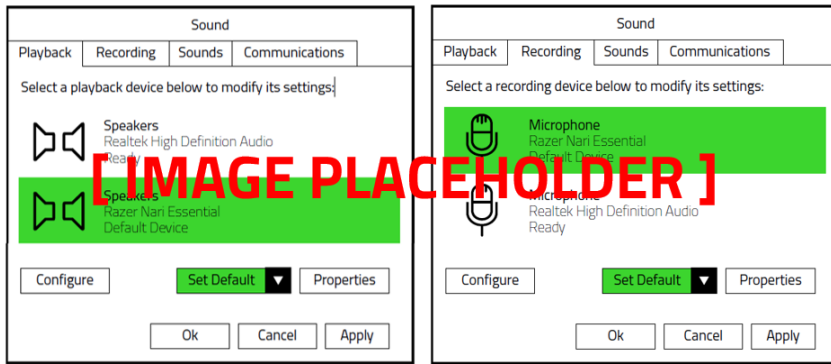

Your headset is now ready to use.

## B. TO OTHER DEVICES VIA USB PORT

Plug the USB wireless transceiver to your device and make sure your Razer BlackShark V2 Pro is the default input and output audio device.

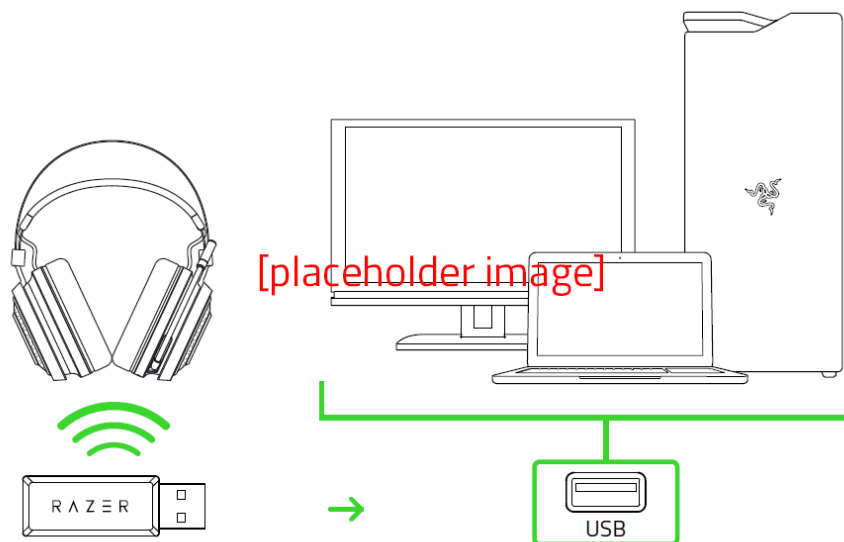

### C. TO DEVICES VIA 3.5MM COMBO PORT

If your device has a 3.5mm audio + mic combined jack, simply plug the 3.5mm combo cable from your headset to your device's audio jack.

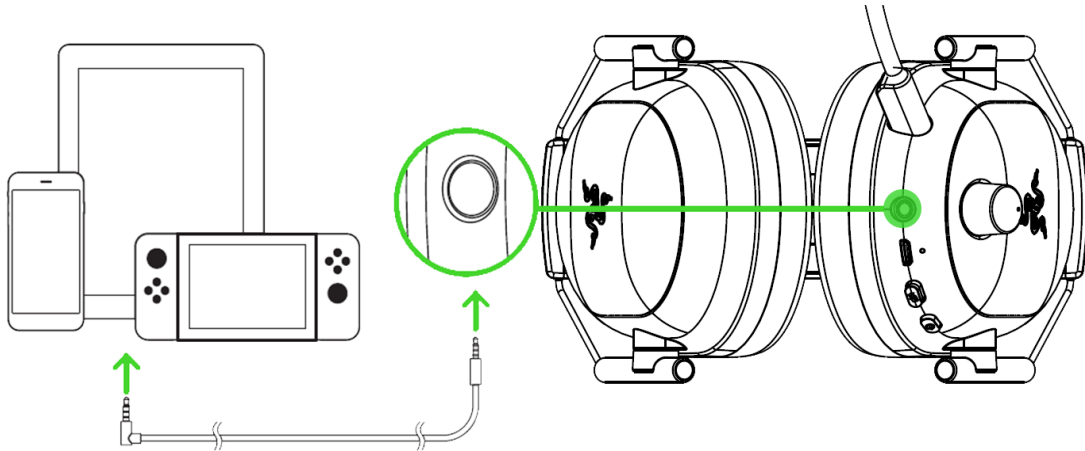

### POWER BUTTON FUNCTIONS

#### Power ON/OFF

Power on or off your headset by holding the power button for at least 3 seconds or until you hear 2 short beeps.

#### Play / Pause a track

While powered on, press the power button to play or pause the current track.

#### Next track

While powered on, double press the power button to go to the next track.

#### Previous track

While powered off, triple press the power button to go to the previous track.



## ADJUSTING THE VOLUME

Rotate the volume knob as shown to increase or decrease the volume.

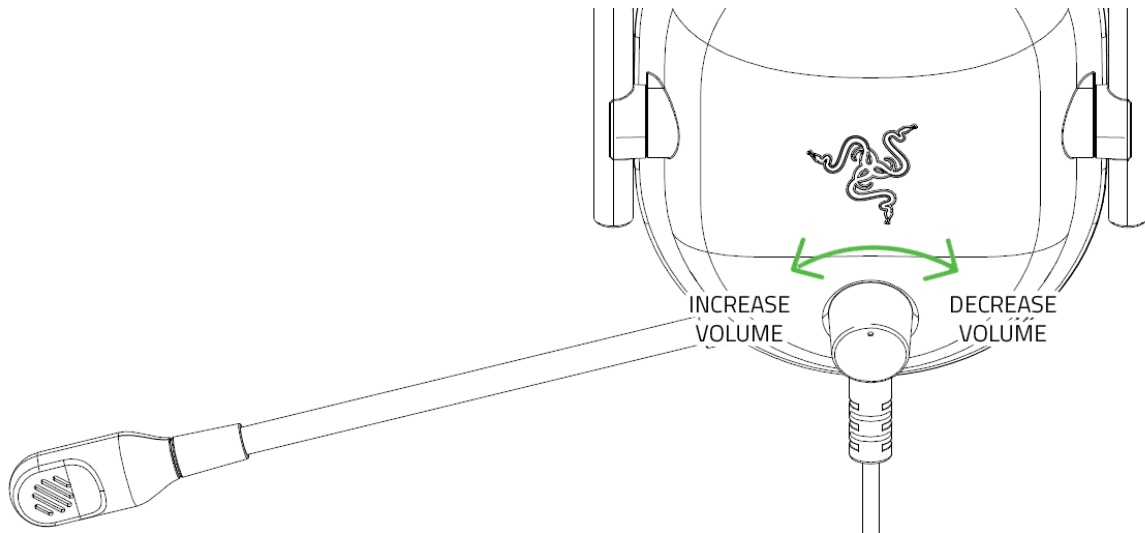

## USING THE RAZER™ HYPERCLEAR SUPERCARDIOID MIC

Plug the Razer™ HyperClear Supercardioid Mic to the headphone and bend until it is parallel to your mouth. Make sure the mic diaphragm is in front and the air vent is facing away from your mouth.

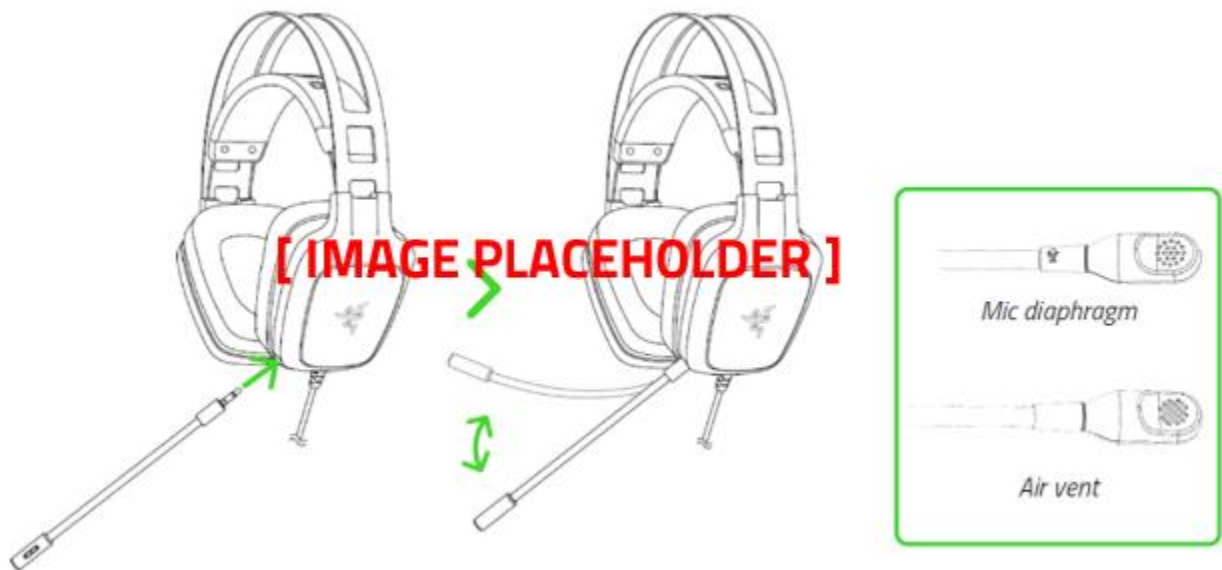

## MUTING / UNMUTING THE MICROPHONE

Press the mic mute button to mute or unmute the microphone.

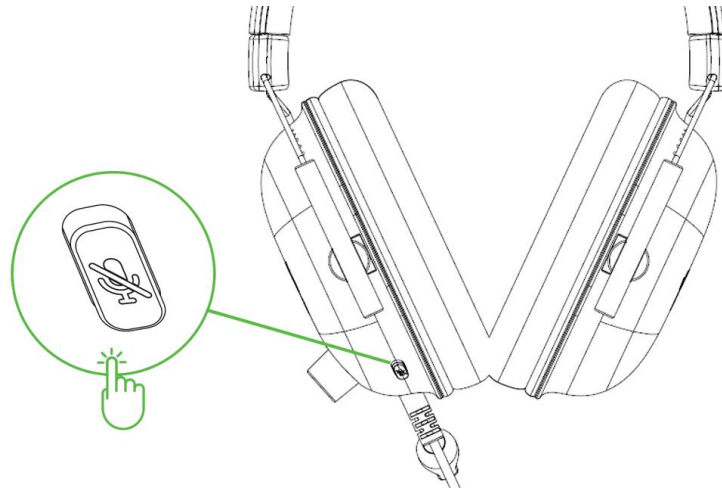

## EXTENDING YOUR HEADSET'S LIFESPAN

We recommend stretching the headset gently apart before placing them over your head to minimize headband stress. However, please avoid overstretching the headset beyond its technical limits.



## ACTIVATE THX SPATIAL AUDIO

Unleash the full potential of your Razer BlackShark V2 Pro by enabling 360° positional audio for a natural and lifelike experience through Razer Synapse.

Find out more about your new headset at [support.razer.com](https://support.razer.com).

### FCC Statement

This equipment has been tested and found to comply with the limits for a Class B digital device, pursuant to part 15 of the FCC Rules. These limits are designed to provide reasonable protection against harmful interference in a residential installation. This equipment generates, uses and can radiate radio frequency energy and, if not installed and used in accordance with the instructions, may cause harmful interference to radio communications. However, there is no guarantee that interference will not occur in a particular installation. If this equipment does cause harmful interference to radio or television reception, which can be determined by turning the equipment off and on, the user is encouraged to try to correct the interference by one or more of the following measures:

- Reorient or relocate the receiving antenna.
- Increase the separation between the equipment and receiver.
- Connect the equipment into an outlet on a circuit different from that to which the receiver is connected.
- Consult the dealer or an experienced radio/TV technician for help.

### FCC Radiation Exposure Statement

This device complies with FCC radiation exposure limits set forth for an uncontrolled environment and it also complies with Part 15 of the FCC RF Rules. This equipment must not be co-located or operating in conjunction with any other antenna or transmitter. End-users and installers must be provide with antenna installation instructions and consider removing the no-collocation statement.

This device complies with Part 15 of the FCC Rules. Operation is subject to the following two conditions:

- (1) this device may not cause harmful interference, and
- (2) this device must accept any interference received, including interference that may cause undesired operation.

### Caution!

Any changes or modifications not expressly approved by the party responsible for compliance could void the user's authority to operate the equipment.

---

## SAFETY AND MAINTENANCE

### SAFETY GUIDELINES

In order to achieve maximum safety while using your Razer BlackShark V2 Pro, we suggest that you adopt the following guidelines:

Should you have trouble operating the device properly and troubleshooting does not work, unplug the device and contact the Razer hotline or go to [support.razer.com](https://support.razer.com) for assistance.

Do not take apart the device (doing so will void your warranty) and do not attempt to operate it under abnormal current loads.

Keep the device away from liquid, humidity or moisture. Operate the device only within the specific temperature range of 0°C (32°F) to 40°C (104°F). Should the temperature exceed this range, unplug and/or switch off the device in order to let the temperature stabilize to an optimal level.

The device isolates external ambient sounds even at low volumes, resulting in lowered awareness of your external surroundings. Please remove the device when engaging in any activities that requires active awareness of your surroundings.

Listening to excessively loud volumes over extended periods of time can damage your hearing. Furthermore, legislation of certain countries permits a maximum sound level of 86db to affect your hearing for 8 hours a day. We therefore recommend that you reduce the volume to a comfortable level when listening for prolonged periods of time. Please, take good care of your hearing.

### MAINTENANCE AND USE

The Razer BlackShark V2 Pro requires minimum maintenance to keep it in optimum condition. Once a month we recommend you unplug the device from the computer and clean it using a soft cloth or cotton swab to prevent dirt buildup. Do not use soap or harsh cleaning agents.

---

## LEGALESE

### **COPYRIGHT AND INTELLECTUAL PROPERTY INFORMATION**

©2020 Razer Inc. All rights reserved. Razer, the triple-headed snake logo, Razer logo, and “For Gamers. By Gamers.” are trademarks or registered trademarks of Razer Inc. and/or affiliated companies in the United States or other countries. All other trademarks are the property of their respective owners.

The Bluetooth® word mark and logos are registered trademarks owned by Bluetooth SIG, Inc., and any use of such marks by Razer is under license.

Windows and the Windows logo are trademarks or registered trademarks of the Microsoft group of companies.

Razer Inc. (“Razer”) may have copyright, trademarks, trade secrets, patents, patent applications, or other intellectual property rights (whether registered or unregistered) concerning the product in this guide. Furnishing of this guide does not give you a license to any such copyright, trademark, patent or other intellectual property right. The Razer BlackShark V2 Pro (the “Product”) may differ from pictures whether on packaging or otherwise. Razer assumes no responsibility for such differences or for any errors that may appear. Information contained herein is subject to change without notice.

### **LIMITED PRODUCT WARRANTY**

For the latest and current terms of the Limited Product Warranty, please visit [razer.com/warranty](https://www.razer.com/warranty).

### **LIMITATION OF LIABILITY**

Razer shall in no event be liable for any lost profits, loss of information or data, special, incidental, indirect, punitive or consequential or incidental damages, arising in any way out of distribution of, sale of, resale of, use of, or inability to use the Product. In no event shall Razer’s liability exceed the retail purchase price of the Product.

### **GENERAL**

These terms shall be governed by and construed under the laws of the jurisdiction in which the Product was purchased. If any term herein is held to be invalid or unenforceable, then such term (in so far as it is invalid or unenforceable) shall be given no effect and deemed to be excluded without invalidating any of the remaining terms. Razer reserves the right to amend any term at any time without notice.