

FCC RADIO TEST REPORT

| | |
|------------------|-------------------------------------------------------------------------------------------------------------------------------------|
| Prepared For | Shenzhen Forrinx Electronics Co., Ltd. |
| Product Name: | wireless doorbell |
| Trade Name: | N/A |
| Model Name : | A,B,C,D,E,F,G,H,I,J,K,L,M,N,218,228,328,338,358,368,518,528,538,568,618,658,668,728,758,768,818,828,838,868,528-2,638-2,758-2,818-2 |
| FCC ID: | RWEFORRINX |
| Prepared By | DongGuan Precise Testing Service Co.,Ltd. |
| | F616A Room, 6th Floor, Meixin Business Center, Dongcheng Middle Road, Dongguan, Guangdong, China |
| Report No. | PTS201301059F |
| Test Date: | Dec 28, 2012 ~ Jan 22, 2013 |
| Date of Report : | Jan 25, 2013 |



VERIFICATION OF COMPLIANCE

| | |
|----------------------|-------------------------------------------------------------------------------------------------------------------------------------|
| Applicant: | Shenzhen Forrinx Electronics Co., Ltd. |
| Address | Building 9, No.18, North Area of Makan Industrial Park, Xili Town, Nanshan District, Shenzhen, China |
| Manufacturer Name: | Shenzhen Forrinx Electronics Co., Ltd. |
| Address: | Building 9, No.18, North Area of Makan Industrial Park, Xili Town, Nanshan District, Shenzhen, China |
| Product Description: | wireless doorbell |
| Brand Name: | N/A |
| Model Name: | A,B,C,D,E,F,G,H,I,J,K,L,M,N,218,228,328,338,358,368,518,528,538,568,618,658,668,728,758,768,818,828,838,868,528-2,638-2,758-2,818-2 |
| Model difference: | Model name is different. |
| Test procedure | ANSI C63.4 |
| Standards | FCC Part15.231 |

Prepared by :

Assistant

Reviewer :

Supervisor

Approved & Authorized Signer :

Jacky Ou / Manager

Table of Contents

Page

| | |
|-------------------------------------------------------------|-----------|
| 1 . SUMMARY OF TEST RESULTS | 4 |
| 1.1 TEST FACILITY | 5 |
| 1.2 MEASUREMENT UNCERTAINTY | 5 |
| 2 . GENERAL INFORMATION | 6 |
| 2.1 GENERAL DESCRIPTION OF EUT | 6 |
| 2.2 DESCRIPTION OF TEST MODES | 7 |
| 2.3 BLOCK DIGRAM SHOWING THE CONFIGURATION OF SYSTEM TESTED | 8 |
| 2.4 DESCRIPTION OF SUPPORT UNITS(CONDUCTED MODE) | 9 |
| 2.5 EQUIPMENTS LIST FOR ALL TEST ITEMS | 10 |
| 3 . ANTENNA REQUIREMENT | 11 |
| 3.1 STANDARD REQUIREMENT | 11 |
| 3.2 EUT ANTENNA | 11 |
| 3.3 CONDUCTED EMISSION MEASUREMENT | 12 |
| 3.3.1 POWER LINE CONDUCTED EMISSION LIMITS | 12 |
| 3.3.2 TEST PROCEDURE | 13 |
| 3.3.3 DEVIATION FROM TEST STANDARD | 13 |
| 3.3.4 TEST SETUP | 13 |
| 3.2.5 TEST RESULT | 14 |
| 3.4 RADIATED EMISSION MEASUREMENT | 15 |
| 3.4.1 RADIATED EMISSION LIMITS | 15 |
| 3.4.2 TEST PROCEDURE | 16 |
| 3.4.3 DEVIATION FROM TEST STANDARD | 16 |
| 3.4.4 TEST SETUP | 17 |
| 3.4.5 TEST RESULTS (BLOW 30MHZ) | 19 |
| 3.4.6 TEST RESULTS (BETWEEN 30 – 1000 MHZ) | 20 |
| 4 . BANDWIDTH TEST | 23 |
| 4.1 TEST PROCEDURE | 23 |
| 4.2 DEVIATION FROM STANDARD | 23 |
| 4.3 TEST SETUP | 23 |
| 4.4 TEST RESULTS | 24 |
| 5 . TRANSMITTER TIMEOUT | 25 |
| 5.1 REQUIREMENTS | 25 |
| 6 . EUT TEST PHOTO | 27 |
| APPENDIX-PHOTOGRAPHS OF EUT CONSTRUCTIONAL DETAILS | |

1. SUMMARY OF TEST RESULTS

Test procedures according to the technical standards:

| FCC Part15, Subpart C (15.231) | | | |
|---------------------------------------|----------------------------|----------|---------|
| Standard Section | Test Item | Judgment | Remark |
| 15.207 | Conducted Emission | N/A | Note(1) |
| 15.203 | Antenna Requirement | Pass | |
| 15.231b | Radiated Spurious Emission | Pass | |
| 15.231c | Occupied Bandwidth | Pass | |
| 15.231a(1) | Transmitter Timeout | Pass | |

NOTE:

(1) " N/A" denotes test is not applicable in this Test Report.

1.1 TEST FACILITY

NTEK Testing Technology Co., Ltd

Add. : 1/F, Building E, Fenda Science Park, Sanwei Community, Xixiang Street, Bao'an District, Shenzhen P.R. China.

FCC Registration No.:238937; IC Registration No.:9270A-1

1.2 MEASUREMENT UNCERTAINTY

The reported uncertainty of measurement $y \pm U$, where expanded uncertainty U is based on a standard uncertainty multiplied by a coverage factor of $k=2$, providing a level of confidence of approximately **95 %**.

| No. | Item | Uncertainty |
|-----|------------------------------|---------------------------|
| 1 | Conducted Emission Test | $\pm 1.38\text{dB}$ |
| 2 | RF power,conducted | $\pm 0.16\text{dB}$ |
| 3 | Spurious emissions,conducted | $\pm 0.21\text{dB}$ |
| 4 | All emissions,radiated(<1G) | $\pm 4.68\text{dB}$ |
| 5 | All emissions,radiated(>1G) | $\pm 4.89\text{dB}$ |
| 6 | Temperature | $\pm 0.5^{\circ}\text{C}$ |
| 7 | Humidity | $\pm 2\%$ |

2. GENERAL INFORMATION

2.1 GENERAL DESCRIPTION OF EUT

| | | |
|---------------------------------------------------------------------------------|-----------------------------------------------------------------------------------------------------------------------------------|--------------------------|
| Equipment | wireless doorbell | |
| Trade Name | N/A | |
| Model Name | A | |
| Serial Model | B,C,D,E,F,G,H,I,J,K,L,M,N,218,228,328,338,358,368,518,528,538,568,618,658,668,728,758,768,818,828,838,868,528-2,638-2,758-2,818-2 | |
| Model Difference | Model name is different. | |
| Product Description | The EUT is a wireless doorbell | |
| | Product Type | Remote Control |
| | Operation Frequency: | 315.1MHz |
| | Modulation Type: | ASK |
| | Number Of Channel | 1CH. |
| | Antenna Designation: | PCB Printed antenna |
| | Antenna Gain(Peak) | 2.0dBi |
| | max. Field Strength | 74.05dBuV/m @3m(AV Max.) |
| More details of EUT technical specification, please refer to the User's Manual. | | |
| Channel List | N/A | |
| Adapter | N/A | |
| Battery | DC 12.0V | |

Note:

1. For a more detailed features description, please refer to the manufacturer's specifications or the User's Manual.
- 2.

Table for Filed Antenna

| Ant | Brand | Model Name | Antenna Type | Connector | Gain (dBi) | NOTE |
|-----|-------|------------|---------------------|-----------|------------|---------|
| 1 | N/A | N/A | PCB Printed antenna | NA | 2.0 | Antenna |

2.2 DESCRIPTION OF TEST MODES

To investigate the maximum EMI emission characteristics generates from EUT, the test system was pre-scanning tested base on the consideration of following EUT operation mode or test configuration mode which possible have effect on EMI emission level. Each of these EUT operation mode(s) or test configuration mode(s) mentioned above was evaluated respectively.

| Pretest Mode | Description |
|--------------|-------------|
| Mode 1 | TX |

| For Conducted Emission | |
|------------------------|-------------|
| Final Test Mode | Description |
| Mode 1 | N/A |

| For Radiated Emission | |
|-----------------------|-------------|
| Final Test Mode | Description |
| Mode 1 | TX |

Note:

(1) The EUT use new battery.

2.3 BLOCK DIGRAM SHOWING THE CONFIGURATION OF SYSTEM TESTED

Radiated Spurious Emission Test



2.4 DESCRIPTION OF SUPPORT UNITS(CONDUCTED MODE)

The EUT has been tested as an independent unit together with other necessary accessories or support units. The following support units or accessories were used to form a representative test configuration during the tests.

| Item | Equipment | Mfr/Brand | Model/Type No. | Series No. | Note |
|------|-------------------|-----------|----------------|------------|------|
| E-1 | wireless doorbell | N/A | A | N/A | EUT |
| | | | | | |
| | | | | | |
| | | | | | |
| | | | | | |

| Item | Shielded Type | Ferrite Core | Length | Note |
|------|---------------|--------------|--------|------|
| | | | | |
| | | | | |
| | | | | |
| | | | | |
| | | | | |

Note:

- (1) The support equipment was authorized by Declaration of Confirmation.
- (2) For detachable type I/O cable should be specified the length in cm in 『Length』 column.

2.5 EQUIPMENTS LIST FOR ALL TEST ITEMS

Radiation Test equipment

| Item | Kind of Equipment | Manufacturer | Type No. | Serial No. | Last calibration | Calibrated until | Calibration period |
|------|--------------------|--------------|-------------|--------------|------------------|------------------|--------------------|
| 1 | Spectrum Analyzer | Agilent | E4407B | MY45108040 | 2012.07.06 | 2013.07.05 | 1 year |
| 2 | Test Receiver | R&S | ESPI | 101318 | 2012.06.07 | 2013.06.06 | 1 year |
| 3 | Bilog Antenna | TESEQ | CBL6111D | 31216 | 2012.07.06 | 2013.07.05 | 1 year |
| 4 | 50Ω Coaxial Switch | Anritsu | MP59B | 6200264416 | 2012.06.07 | 2013.06.06 | 1 year |
| 5 | Spectrum Analyzer | ADVANTEST | R3132 | 150900201 | 2012.06.07 | 2013.06.06 | 1 year |
| 6 | Horn Antenna | EM | EM-AH-10180 | 2011071402 | 2012.07.06 | 2013.07.05 | 1 year |
| 7 | Horn Ant | Schwarzbeck | BBHA 9170 | 9170-181 | 2012.07.06 | 2013.07.05 | 1 year |
| 8 | Amplifier | EM | EM-30180 | 060538 | 2012.12.22 | 2013.12.21 | 1 year |
| 9 | Loop Antenna | ARA | PLA-1030/B | 1029 | 2012.06.08 | 2013.06.07 | 1 year |
| 10 | Power Meter | R&S | NRVS | 100696 | 2012.07.06 | 2013.07.05 | 1 year |
| 11 | Power Sensor | R&S | URV5-Z4 | 0395.1619.05 | 2012.07.06 | 2013.07.05 | 1 year |

Conduction Test equipment

| Item | Kind of Equipment | Manufacturer | Type No. | Serial No. | Last calibration | Calibrated until | Calibration period |
|------|-----------------------|--------------|----------|------------|------------------|------------------|--------------------|
| 1 | Test Receiver | R&S | ESCI | 101160 | 2012.06.06 | 2013.06.05 | 1 year |
| 2 | LISN | R&S | ENV216 | 101313 | 2012.08.24 | 2013.08.23 | 1 year |
| 3 | LISN | EMCO | 3816/2 | 00042990 | 2012.08.24 | 2013.08.23 | 1 year |
| 4 | 50Ω Coaxial Switch | Anritsu | MP59B | 6200264417 | 2012.06.07 | 2013.06.06 | 1 year |
| 5 | Passive Voltage Probe | R&S | ESH2-Z3 | 100196 | 2012.06.07 | 2013.06.06 | 1 year |
| 6 | Absorbing clamp | R&S | MOS-21 | 100423 | 2012.06.08 | 2013.06.07 | 1 year |

3. ANTENNA REQUIREMENT

3.1 STANDARD REQUIREMENT

15.203 requirement: For intentional device, according to 15.203: an intentional radiator shall be designed to ensure that no antenna other than that furnished by the responsible party shall be used with the device.

3.2 EUT ANTENNA

The EUT antenna is PCB Printed antenna. It comply with the standard requirement.

3.3 CONDUCTED EMISSION MEASUREMENT

3.3.1 POWER LINE CONDUCTED EMISSION Limits (Frequency Range 150KHz-30MHz)

| FREQUENCY (MHz) | Class A (dBuV) | | Class B (dBuV) | | Standard |
|-----------------|----------------|---------|----------------|-----------|----------|
| | Quasi-peak | Average | Quasi-peak | Average | |
| 0.15 -0.5 | | | 66 - 56 * | 56 - 46 * | CISPR |
| 0.50 -5.0 | | | 56.00 | 46.00 | CISPR |
| 5.0 -30.0 | | | 60.00 | 50.00 | CISPR |

| | | | | | |
|-----------|--|--|-----------|-----------|--------|
| 0.15 -0.5 | | | 66 - 56 * | 56 - 46 * | LP002. |
| 0.50 -5.0 | | | 56.00 | 46.00 | LP002. |
| 5.0 -30.0 | | | 60.00 | 50.00 | LP002. |

Note:

- (1) The tighter limit applies at the band edges.
- (2) The limit of " * " marked band means the limitation decreases linearly with the logarithm of the frequency in the range.

The following table is the setting of the receiver

| Receiver Parameters | Setting |
|---------------------|----------|
| Attenuation | 10 dB |
| Start Frequency | 0.15 MHz |
| Stop Frequency | 30 MHz |
| IF Bandwidth | 9 kHz |

3.3.2 TEST PROCEDURE

- a. The EUT was placed 0.4 meters from the horizontal ground plane with EUT being connected to the power mains through a line impedance stabilization network (LISN). All other support equipments powered from additional LISN(s). The LISN provide 50 Ohm/ 50uH of coupling impedance for the measuring instrument.
- b. Interconnecting cables that hang closer than 40 cm to the ground plane shall be folded back and forth in the center forming a bundle 30 to 40 cm long.
- c. I/O cables that are not connected to a peripheral shall be bundled in the center. The end of the cable may be terminated, if required, using the correct terminating impedance. The overall length shall not exceed 1 m.
- d. LISN at least 80 cm from nearest part of EUT chassis.
- e. For the actual test configuration, please refer to the related Item –EUT Test Photos.

3.3.3 DEVIATION FROM TEST STANDARD

No deviation

3.3.4 TEST SETUP

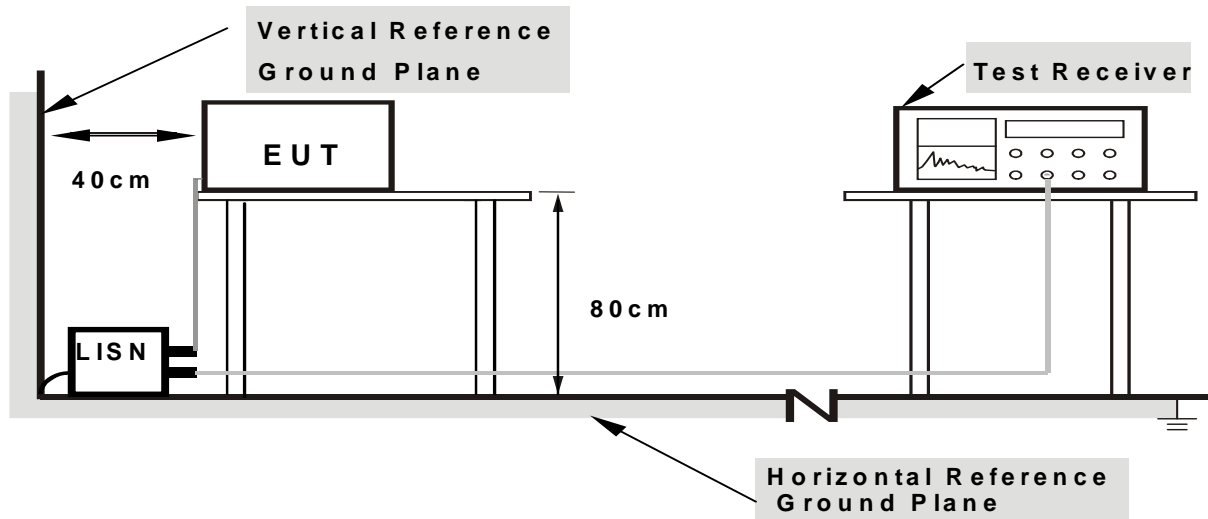

- Note:**
- 1. Support units were connected to second LISN.
 - 2. Both of LISNs (AMN) are 80 cm from EUT and at least 80 from other units and other metal planes

3.2.5 TEST RESULT

| | | | |
|----------------|-------------------|---------------------|-----|
| EUT : | wireless doorbell | Model Name. : | A |
| Temperature : | 26 °C | Relative Humidity : | 54% |
| Pressure : | 1010hPa | Phase : | L |
| Test Voltage : | N/A | Test Mode : | N/A |

Note: It is powered by the battery,Conduction emission test is not applicable.

3.4 RADIATED EMISSION MEASUREMENT

3.4.1 Radiated Emission Limits (FCC 15.209)

| Frequencies (MHz) | Field Strength (micorvolts/meter) | Measurement Distance (meters) |
|-------------------|-----------------------------------|-------------------------------|
| 0.009~0.490 | 2400/F(KHz) | 300 |
| 0.490~1.705 | 24000/F(KHz) | 30 |
| 1.705~30.0 | 30 | 30 |
| 30~88 | 100 | 3 |
| 88~216 | 150 | 3 |
| 216~960 | 200 | 3 |
| Above 960 | 500 | 3 |

Note:

- (1) The tighter limit applies at the band edges.
- (2) Emission level (dBuV/m)=20log Emission level (uV/m).

LIMITS OF RADIATED EMISSION MEASUREMENT (FCC 15.231)

| Fundamental Frequency (MHz) | Field Strength of fundamental (microvolts/meter) | Field Strength of Unwanted Emissions (microvolts/meter) |
|-----------------------------|--------------------------------------------------|---------------------------------------------------------|
| 40.66 - 40.70 | 2250.00 | 225.00 |
| 70 - 130 | 1250.00 | 125.00 |
| 130 - 174 | 1,250 to 3,750 ** | 125 to 375 ** |
| 174 - 260 | 3750.00 | 375.00 |
| 260 - 470 | 3,750 to 12,500 ** | 375 to 1,250 ** |
| Above 470 | 12500.00 | 1250.00 |

Notes:

- (1) ** linear interpolations

[Where F is the frequency in MHz, the formulas for calculating the maximum permitted fundamental field strengths are as follows: for the band 130-174 MHz, uV/m at 3 meters = 56.81818(F) - 6136.3636; for the band 260-470 MHz, uV/m at 3 meters = 41.6667(F) - 7083.3333. The maximum permitted unwanted emission level is 20 dB below the maximum permitted fundamental level.]

The limits on the field strength of the spurious emissions in the above table are based on the fundamental frequency of the intentional radiator. Spurious emissions shall be attenuated to the average (or, alternatively, CISPR quasi-peak) limits shown in this table or to the general limits shown in 93 Section 15.209, whichever limit permits a higher field strength.

| Spectrum Parameter | Setting |
|---------------------------------------|-----------------------|
| Attenuation | Auto |
| Start Frequency | 1000 MHz |
| Stop Frequency | 10th carrier harmonic |
| RB / VB (emission in restricted band) | 1MHz / 1MHz for Peak |

| Receiver Parameter | Setting |
|------------------------|----------------------------------|
| Attenuation | Auto |
| Start ~ Stop Frequency | 9kHz~150kHz / RB 200Hz for QP |
| Start ~ Stop Frequency | 150kHz~30MHz / RB 9kHz for QP |
| Start ~ Stop Frequency | 30MHz~1000MHz / RB 120kHz for QP |

3.4.2 TEST PROCEDURE

- a. The measuring distance of at 3 m shall be used for measurements at frequency up to 1GHz. For frequencies above 1GHz, any suitable measuring distance may be used.
- b. The EUT was placed on the top of a rotating table 0.8 meters above the ground at a 3m meter open area test site. The table was rotated 360 degrees to determine the position of the highest radiation.
- c. The height of the equipment or of the substitution antenna shall be 0.8 m; the height of the test antenna shall vary between 1 m to 4 m.
- d. The initial step in collecting conducted emission data is a spectrum analyzer peak detector mode pre-scanning the measurement frequency range.
- e. For the actual test configuration, please refer to the related Item –EUT Test Photos.

Note:

Both horizontal and vertical antenna polarities were tested and performed pretest to three orthogonal axis. The worst case emissions were reported

3.4.3 DEVIATION FROM TEST STANDARD

No deviation

3.4.4 TEST SETUP

(A) Radiated Emission Test-Up Frequency Below 30MHz

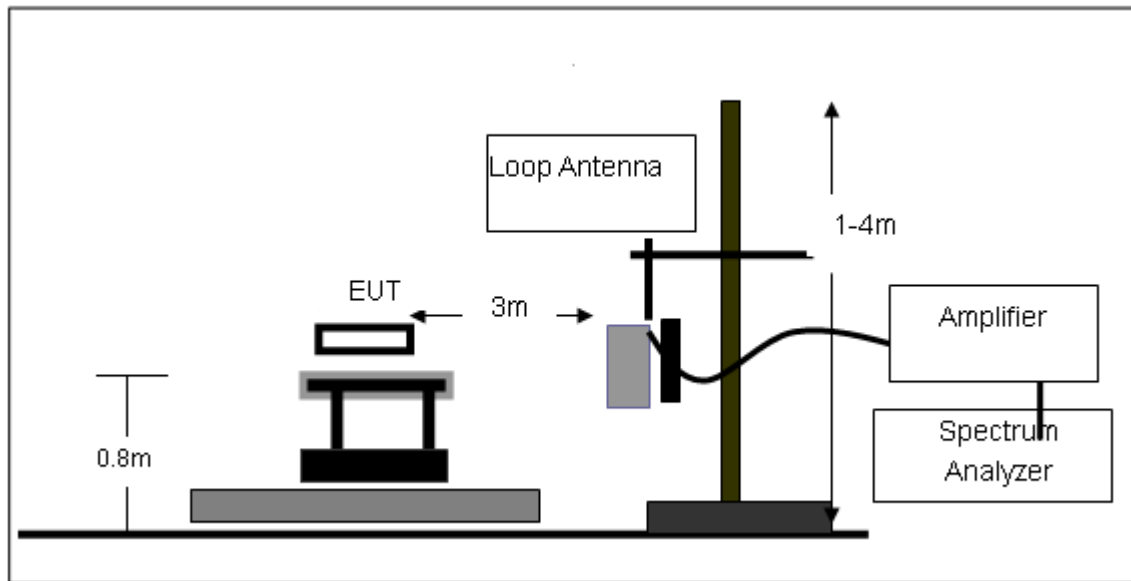

(B) Radiated Emission Test-Up Frequency 30MHz~1GHz

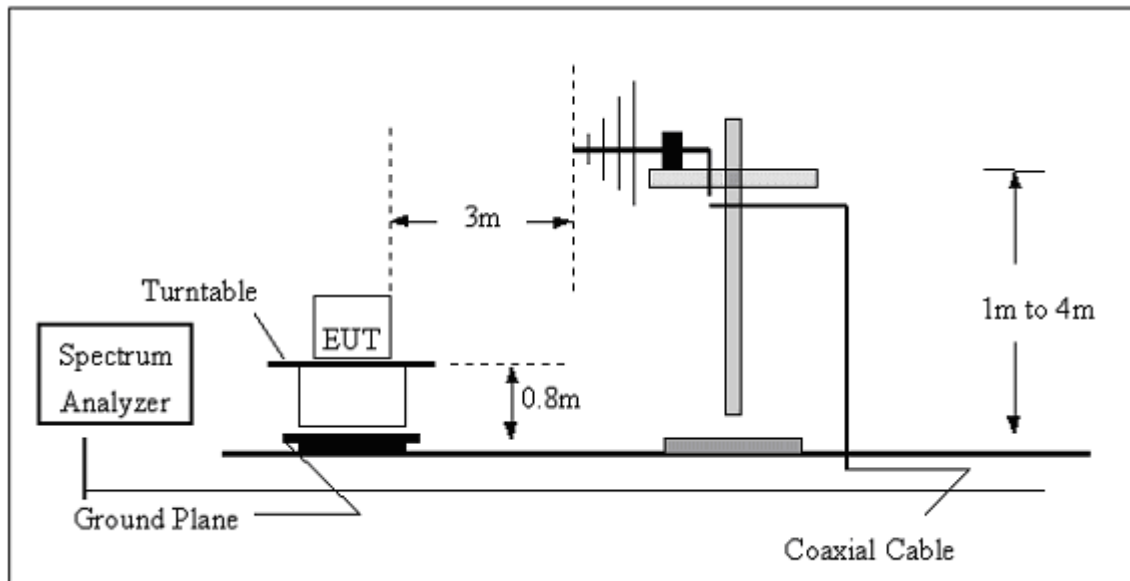

(C) Radiated Emission Test-Up Frequency Above 1GHz

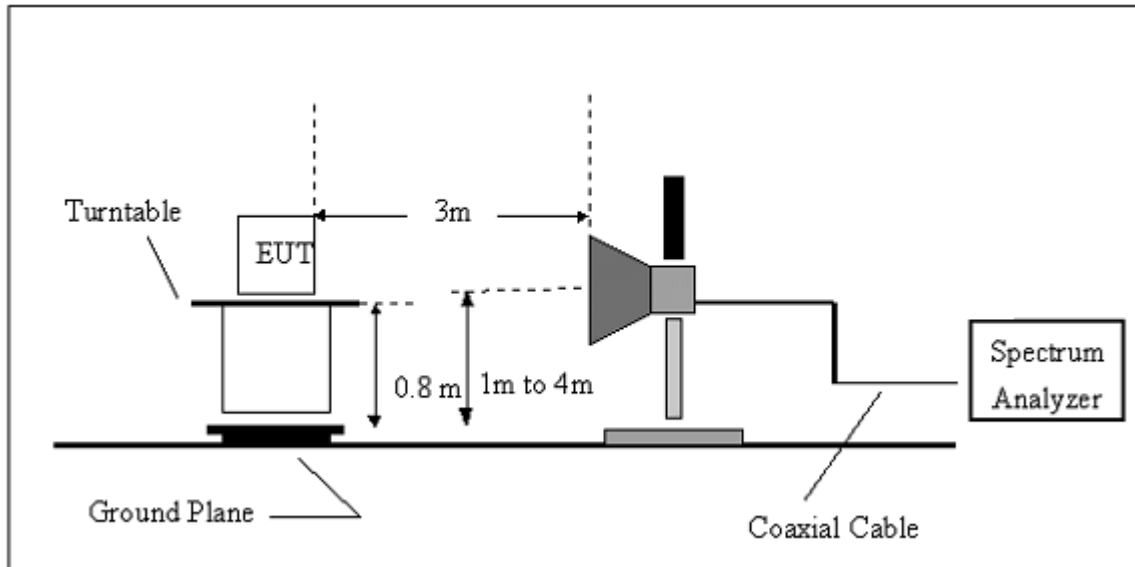

3.4.5 TEST RESULTS (BLOW 30MHz)

| | | | |
|---------------|-------------------|---------------------|----------|
| EUT : | wireless doorbell | Model Name. : | A |
| Temperature : | 20 °C | Relative Humidity : | 48% |
| Pressure : | 1010 hPa | Test Voltage : | DC 12.0V |
| Test Mode : | TX | Polarization : | -- |

| Freq. | Reading | Limit | Margin | State |
|-------|----------|----------|--------|-------|
| (MHz) | (dBuV/m) | (dBuV/m) | (dB) | P/F |
| -- | -- | -- | -- | PASS |
| -- | -- | -- | -- | PASS |

NOTE:

The amplitude of spurious emissions which are attenuated by more than 20dB below the permissible value has no need to be reported.

Distance extrapolation factor = $20 \log (\text{specific distance}/\text{test distance})(\text{dB})$;

Limit line = specific limits(dBuv) + distance extrapolation factor.

3.4.6 TEST RESULTS (BETWEEN 30 – 1000 MHZ)

The duty cycle is simply the on time divided by the period:

The duration of one cycle = 27.75ms

Effective period of the cycle = $(13 \times 0.625) + (12 \times 0.200)$ ms = 10.525ms

DC = $10.525\text{ms} / 27.75\text{ms} = 0.379$

Therefore, the average factor is found by $20\log 0.379 = -8.42\text{dB}$

The duration of one cycle

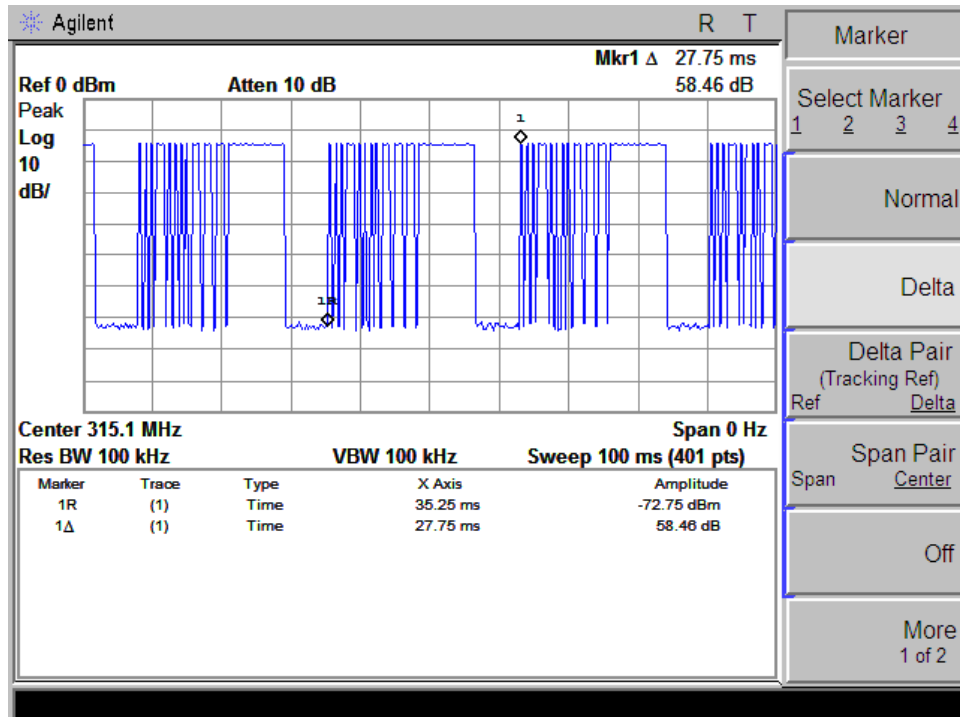

13 long 'on' signals and 12 short 'on' signals

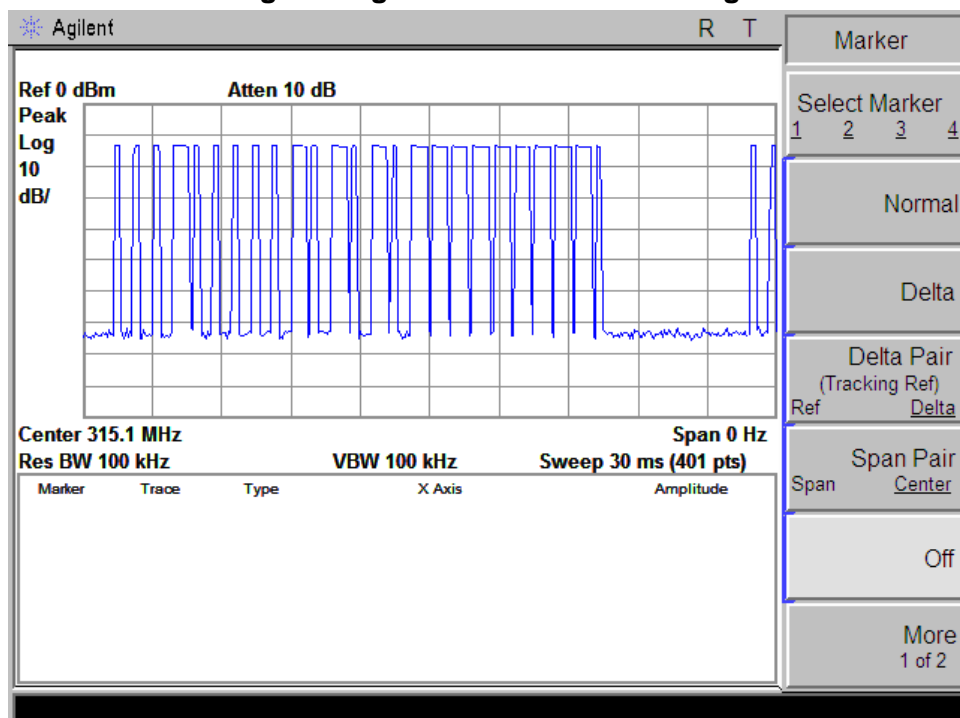

long signal and short signal time

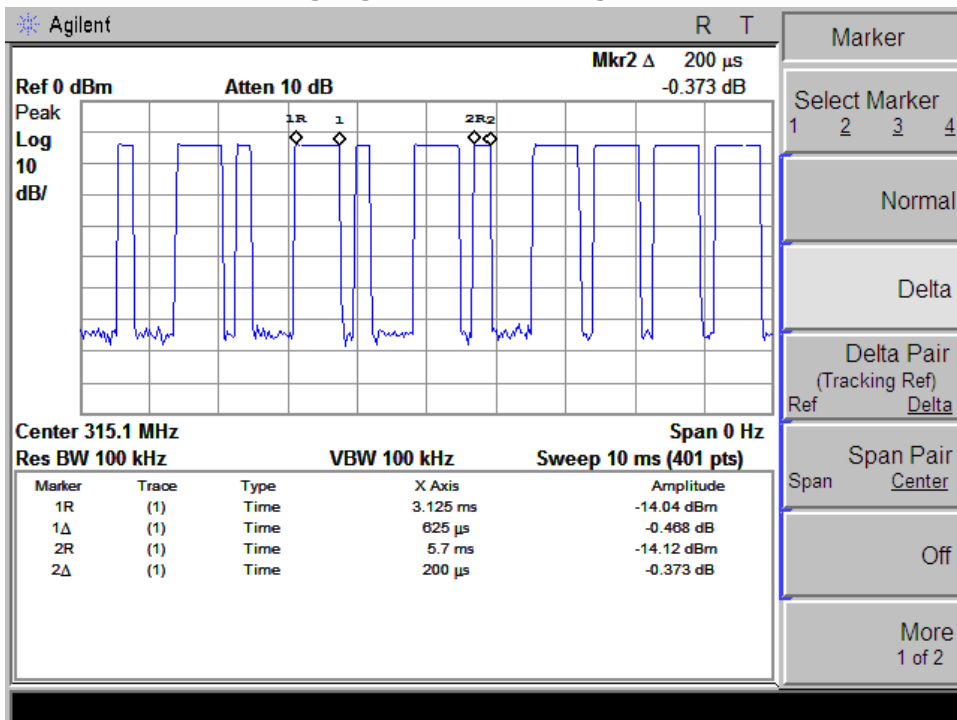

| | | | |
|---------------|-------------------|---------------------|------------|
| EUT : | wireless doorbell | Model Name : | A |
| Temperature : | 20 °C | Relative Humidity : | 48% |
| Pressure : | 1010 hPa | Test Voltage : | DC 12.0V |
| Test Mode : | TX | Polarization : | Horizontal |

| Frequency | Average Factor | Field Strength | Field Strength | Limit(PK) | Limit(AV) | State |
|-----------|----------------|----------------|----------------|-----------|-----------|-------|
| MHz | dB | dBuV/m (PK) | dBuV/m (AV) | dBuV/m | dBuV/m | |
| 315.1056 | -8.42 | 82.47 | 74.05 | 95.62 | 75.62 | pass |
| 630.2193 | -8.42 | 58.42 | 50.00 | 75.62 | 55.62 | pass |
| 945.3141 | -8.42 | 56.83 | 48.41 | 75.62 | 55.62 | pass |
| 1575.528 | -8.42 | 54.45 | 46.03 | 74.00 | 54.00 | pass |
| 1890.532 | -8.42 | 51.35 | 42.93 | 74.00 | 54.00 | pass |
| -- | -- | -- | -- | 74.00 | 54.00 | pass |

| | | | |
|---------------|-------------------|---------------------|----------|
| EUT : | wireless doorbell | Model Name : | A |
| Temperature : | 20 °C | Relative Humidity : | 48% |
| Pressure : | 1010 hPa | Test Voltage : | DC 12.0V |
| Test Mode : | TX | Polarization : | Vertical |

| Frequency | Average Factor | Field Strength | Field Strength | Limit(PK) | Limit(AV) | State |
|-----------|----------------|----------------|----------------|-----------|-----------|-------|
| MHz | dB | dBuV/m (PK) | dBuV/m (AV) | dBuV/m | dBuV/m | |
| 315.1056 | -8.42 | 80.28 | 71.86 | 95.62 | 75.62 | pass |
| 630.2193 | -8.42 | 57.24 | 48.82 | 75.62 | 55.62 | pass |
| 945.3141 | -8.42 | 55.65 | 47.23 | 75.62 | 55.62 | pass |
| 1575.528 | -8.42 | 53.34 | 44.92 | 74.00 | 54.00 | pass |
| 1890.532 | -8.42 | 51.53 | 43.11 | 74.00 | 54.00 | pass |
| -- | -- | -- | -- | 74.00 | 54.00 | pass |

NOTE:

1. Emissions attenuated more than 20 dB below the permissible value are not reported.
2. Field Strength(AV) = Field Strength(PK)+Average Factor.
3. FCC Limit for Average Measurement = 41.6667(315.1)-7083.3333 = 6045.8438uV/m =75.62dBuV/m

4. BANDWIDTH TEST

4.1 TEST PROCEDURE

The bandwidth of the emission shall be no wider than 0.25% of the center frequency for devices operating above 70 MHz and below 900 MHz. For devices operating above 900 MHz, the emission shall be no wider than 0.5% of the center frequency. Bandwidth is determined at the points 20 dB down from the modulated carrier.

Limit: $315.1\text{MHz} \times 0.25\% = 787.7\text{KHz}$

4.2 DEVIATION FROM STANDARD

No deviation.

4.3 TEST SETUP

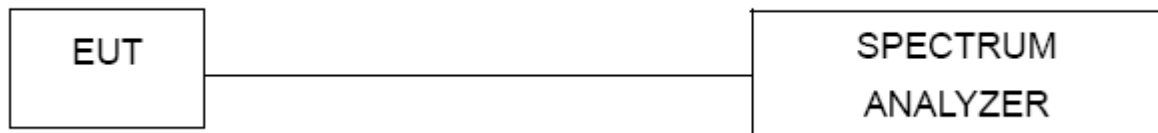

4.4 TEST RESULTS

| | | | |
|---------------|-------------------|---------------------|----------|
| EUT : | wireless doorbell | Model Name : | A |
| Temperature : | 26 °C | Relative Humidity : | 53% |
| Pressure : | 1020 hPa | Test Power : | DC 12.0V |
| Test Mode : | TX CH 1 | | |

| Test Channel | Frequency (MHz) | 20 dBc Bandwidth (kHz) | Limit (kHz) |
|--------------|-----------------|------------------------|-------------|
| CH01 | 315.1 | 66.37 | 787.7 |

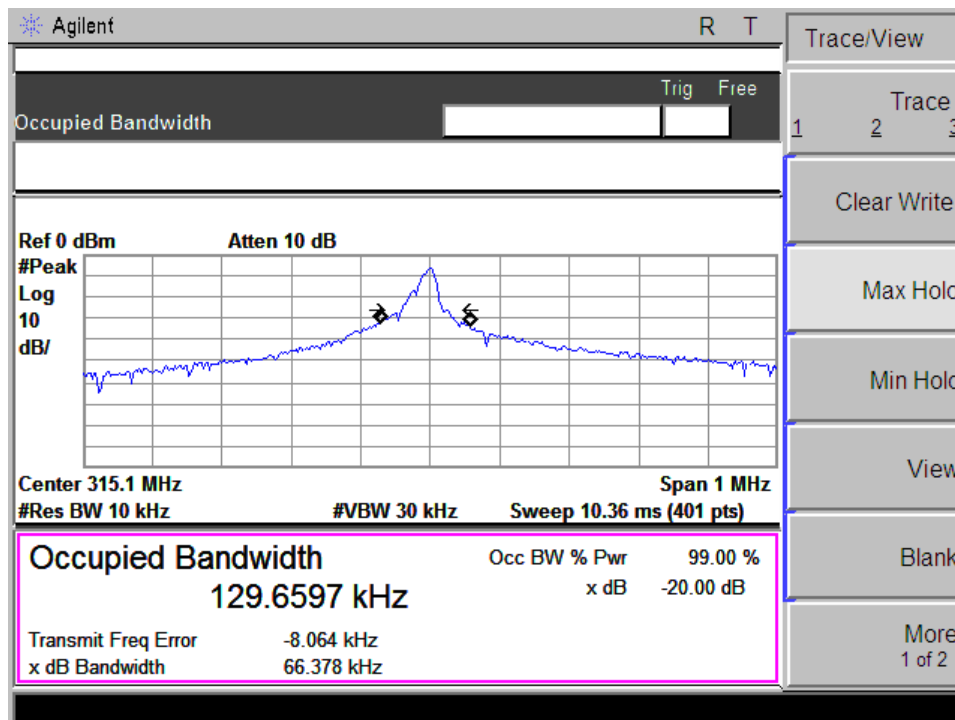

5. TRANSMITTER TIMEOUT

5.1 REQUIREMENTS

47 CFR FCC Part 15 Subpart C, section 15.231(a)/(e):

If devices complying with 47 CFR FCC Part 15 Subpart C, section 15.231(a).

(1) A manually operated transmitter shall employ a switch that will automatically deactivate the transmitter within not more than 5 seconds of being released.

(2) A transmitter activated automatically shall cease transmission within 5 seconds after activation.

(3) Periodic transmissions at regular predetermined intervals are not permitted. However, polling or supervision transmissions, including data, to determine system integrity of transmitters used in security or safety applications are allowed if the total duration of transmissions does not exceed more than two seconds per hour for each transmitter. There is no limit on the number of individual transmissions, provided the total transmission time does not exceed two seconds per hour.

(4) Intentional radiators which are employed for radio control purposes during emergencies involving fire, security, and safety of life, when activated to signal an alarm, may operate during the pendency of the alarm condition.

(5) Transmission of set-up information for security systems may exceed the transmission duration limits in paragraphs 15.231(a) of this section, provided such transmission are under the control of a professional installer and do not exceed ten seconds after a manually operated switch is released or a transmitter is activated automatically. Such set-up information may include data.

If devices complying with 47 CFR FCC Part 15 Subpart C, section 15.231(e)

Intentional radiators may operate at a periodic rate exceeding that specified in section 15.231(a) and may be employed for any type of operation, including operation prohibited section 15.231(a).

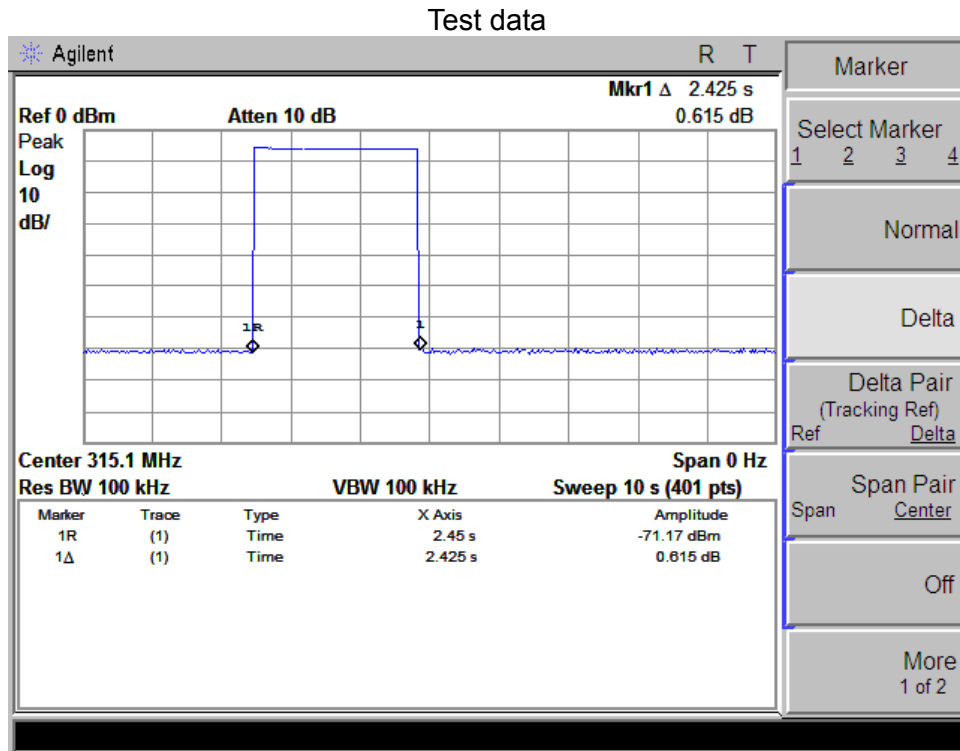

| THE DURATION OF EACH TRANSMISSION | LIMIT | RESULT |
|------------------------------------------------------------------------------------------------------------------------------------------------------------|-------|--------|
| 2.425s | <5s | PASS |
| A manually operated transmitter shall employ a switch that will automatically deactivate the transmitter within not more than 5 seconds of being released. | | |

6. EUT TEST PHOTO

Radiated Measurement Photos

