



FCC TEST REPORT

FCC ID: RWCRX300

Product : Glasses Free 3D Gaming Tablets

Model Name : X300

Brand : Morphus

Report No. : PT800196151217E-FC02

Prepared for

AIKUN(CHINA) ELECTRONICS COMPANY LIMITED
A2 BUILDING, LIANHE INDUSTRIAL PARK, FENG TANG ROAD, FUYONG TOWN,
SHENZHEN, CHINA

Prepared by

DongGuan Precise Testing Service Co.,Ltd.
Building D, Baoding Technology Park, Guangming Road 2, Guangming Community
Dongcheng District, Dongguan, Guangdong, China

TEST RESULT CERTIFICATION

Applicant's name : AIKUN(CHINA) ELECTRONICS COMPANY LIMITED
Address : A2 BUILDING, LIANHE INDUSTRIAL PARK, FENGTANG ROAD,
FUYONG TOWN, SHENZHEN, CHINA

Manufacture's name : AIKUN(CHINA) ELECTRONICS COMPANY LIMITED
Address : A2 BUILDING, LIANHE INDUSTRIAL PARK, FENGTANG ROAD,
FUYONG TOWN, SHENZHEN, CHINA

Product name : Glasses Free 3D Gaming Tablets
Model name : X300

Standards : FCC CFR47 Part 15 Section 15.407

Test procedure : ANSI C63.10:2013

Test Date : Dec. 22, 2015 - May. 10, 2016

Date of Issue : May. 10, 2016

Test Result : Pass

This device described above has been tested by PTS, and the test results show that the equipment under test (EUT) is in compliance with the FCC requirements. And it is applicable only to the tested sample identified in the report.

This report shall not be reproduced except in full, without the written approval of PTS, this document may be altered or revised by PTS, personal only, and shall be noted in the revision of the document.

Testing Engineer

August Qiu

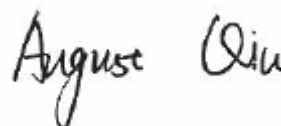

Technical Manager

Hack Ye

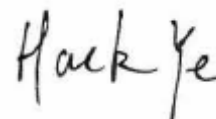

Authorized Signatory

Chris Du

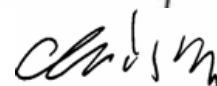

DongGuan Precise Testing Service Co., Ltd.

Building D, Baoding Technology Park, Guangming Road 2, Guangming Community, Dongcheng District, Dongguan, Guangdong, China

Table of Contents

	Page
1 . SUMMARY OF TEST RESULTS	5
1.1 TEST FACILITY	6
1.2 MEASUREMENT UNCERTAINTY	6
2 . GENERAL INFORMATION	7
2.1 GENERAL DESCRIPTION OF EUT	7
2.2 DESCRIPTION OF TEST MODES	9
2.3 BLOCK DIGRAM SHOWING THE CONFIGURATION OF SYSTEM TESTED	10
2.4 DESCRIPTION OF SUPPORT UNITS(CONDUCTED MODE)	10
2.5 EQUIPMENTS LIST FOR ALL TEST ITEMS	11
3 . EMC EMISSION TEST	13
3.1 CONDUCTED EMISSION MEASUREMENT	13
3.1.1 POWER LINE CONDUCTED EMISSION LIMITS	13
3.1.2 TEST PROCEDURE	14
3.1.3 DEVIATION FROM TEST STANDARD	14
3.1.4 TEST SETUP	14
3.1.5 EUT OPERATING CONDITIONS	14
3.1.6 TEST RESULTS	15
3.2 RADIATED EMISSION MEASUREMENT	19
3.2.1 RADIATED EMISSION LIMITS	19
3.2.2 TEST PROCEDURE	20
3.2.3 DEVIATION FROM TEST STANDARD	20
3.2.4 TEST SETUP	21
3.2.5 EUT OPERATING CONDITIONS	22
3.2.6 TEST RESULTS (BETWEEN 9KHZ – 30 MHZ)	23
3.2.7 TEST RESULTS (BETWEEN 30MHZ – 1GHZ)	24
3.2.8 TEST RESULTS (ABOVE 1000 MHZ)	26
4 . MAXIMUM CONDUCTED OUTPUT POWER	30
4.1 APPLIED PROCEDURES / LIMIT	30
4.2 TEST PROCEDURE	30
4.3 DEVIATION FROM STANDARD	30
4.4 TEST SETUP	30
4.5 EUT OPERATION CONDITIONS	30

DongGuan Precise Testing Service Co., Ltd.

Building D, Baoding Technology Park, Guangming Road 2, Guangming Community, Dongcheng District, Dongguan, Guangdong, China

Tel: 86-769-23368601

Fax: 86-769-23368602

[http:// www.pts-testing.com](http://www.pts-testing.com)

Table of Contents		Page
4.6 TEST RESULTS		31
5 . POWER SPECTRAL DENSITY TEST		32
5.1 APPLIED PROCEDURES / LIMIT		32
5.2 TEST PROCEDURE		32
5.3 DEVIATION FROM STANDARD		32
5.4 TEST SETUP		32
5.5 EUT OPERATION CONDITIONS		32
5.6 TEST RESULTS		33
6 . 99% AND 26DB OCCUPIED BANDWIDTH TEST		36
6.1 APPLIED PROCEDURES / LIMIT		36
6.2 TEST PROCEDURE		36
6.3 DEVIATION FROM STANDARD		36
6.4 TEST SETUP		36
6.5 EUT OPERATION CONDITIONS		36
6.6 TEST RESULTS		37
7 . ANTENNA REQUIREMENT		40
7.1 STANDARD REQUIREMENT		40
7.2 EUT ANTENNA		40
8 . EUT TEST PHOTO		41

DongGuan Precise Testing Service Co., Ltd.

Building D, Baoding Technology Park, Guangming Road 2, Guangming Community, Dongcheng District, Dongguan, Guangdong, China

Tel: 86-769-23368601

Fax: 86-769-23368602

[http:// www.pts-testing.com](http://www.pts-testing.com)

1. SUMMARY OF TEST RESULTS

Test procedures according to the technical standards:

FCC Part15 (15.407) , Subpart E			
Standard Section	Test Item	Judgment	Remark
§15.407(a)	Maximum Conducted Output Power	PASS	
§15.407(a)	Power Spectral Density	PASS	
§15.407(a)	26dB Bandwidth	PASS	
§15.407(a)	99% Occupied Bandwidth	PASS	
§15.407(b)	Radiated Emissions	PASS	
§15.407(b)	Band edge Emissions	PASS	
§15.205	Emissions at Restricted Band	PASS	
§15.407(g)	Frequency Stability	PASS	
§15.207(a)	Line Conducted Emissions	PASS	
§15.203	Antenna Requirements	PASS	
§2.1093	RF Exposure	PASS	

NOTE:

- (1) "N/A" denotes test is not applicable in this Test Report
- (2) The manufacture declared frequency stability is better than 20ppm which ensures that the signal remains in the allocated bands under all operational conditions stated in the user manual.

DongGuan Precise Testing Service Co., Ltd.

Building D, Baoding Technology Park, Guangming Road 2, Guangming Community, Dongcheng District, Dongguan, Guangdong, China

Tel: 86-769-23368601

Fax: 86-769-23368602

[http:// www.pts-testing.com](http://www.pts-testing.com)

1.1 TEST FACILITY

FCC Registration No.: 371540, IC Registration No.: 12191A-1

Dongguan Precise Testing Service Co., Ltd.

Add.: Building D, Baoding Technology Park, Guangming Road 2, Dongcheng District, Dongguan, Guangdong, China

1.2 MEASUREMENT UNCERTAINTY

The reported uncertainty of measurement $y \pm U$ where expanded uncertainty U is based on a standard uncertainty multiplied by a coverage factor of $k=2$ providing a level of confidence of approximately **95 %**.

No.	Item	Uncertainty
1	Conducted Emission Test	$\pm 1.38\text{dB}$
2	RF power, conducted	$\pm 0.16\text{dB}$
3	Spurious emissions, conducted	$\pm 0.21\text{dB}$
4	All emissions, radiated (<1G)	$\pm 4.68\text{dB}$
5	All emissions, radiated (>1G)	$\pm 4.89\text{dB}$
6	Temperature	$\pm 0.5^\circ\text{C}$
7	Humidity	$\pm 2\%$

DongGuan Precise Testing Service Co., Ltd.

Building D, Baoding Technology Park, Guangming Road 2, Guangming Community, Dongcheng District, Dongguan, Guangdong, China

Tel: 86-769-23368601

Fax: 86-769-23368602

[http:// www.pts-testing.com](http://www.pts-testing.com)

2. GENERAL INFORMATION

2.1 GENERAL DESCRIPTION OF EUT

Equipment	Glasses Free 3D Gaming Tablets
Trade Name	Morphus
Model Name	X300, RX300
Product Description	<p>Operation Frequency: 5150~5250MHz</p> <p>Modulation Type: 802.11n: OFDM (64QAM, 16QAM,QPSK,BPSK) 802.11a: OFDM (64QAM, 16QAM,QPSK,BPSK)</p> <p>Bit Rate of Transmitter: 802.11n-HT20: 6.5-65 Mbps 802.11n-HT40:13.5-135 Mbps 802.11a: 6-54Mbps</p> <p>Number Of Channel: For 20MHz bandwidth: 4 Channels For 40MHz bandwidth: 2 Channels</p> <p>Antenna Designation: Please see Note 3.</p> <p>Antenna Gain (dBi) -1.5dBi</p> <p>Based on the application, features, or specification exhibited in User's Manual, the EUT is considered as an ITE/Computing Device. More details of EUT technical specification, please refer to the User's Manual.</p>
Channel List:	Please refer to the Note 2.
Power supply:	DC 3.80V by battery Recharge voltage: DC 5V/2A
Connecting I/O Port(s)	Please refer to the User's Manual

Note:

DongGuan Precise Testing Service Co., Ltd.

Building D, Baoding Technology Park, Guangming Road 2, Guangming Community, Dongcheng District, Dongguan, Guangdong, China

Tel: 86-769-23368601

Fax: 86-769-23368602

[http:// www.pts-testing.com](http://www.pts-testing.com)

1. For a more detailed features description, please refer to the manufacturer's specifications or the User's Manual.

2.

Channel List for 802.11n(HT20)/802.11a							
Channel	Frequency (MHz)	Channel	Frequency (MHz)	Channel	Frequency (MHz)	Channel	Frequency (MHz)
36	5180	40	5200	44	5200	48	5240

Channel List for 802.11n(HT40)							
Channel	Frequency (MHz)	Channel	Frequency (MHz)	Channel	Frequency (MHz)	Channel	Frequency (MHz)
38	5190	46	5230	--	--	--	--

3.

Table for Filed Antenna

Ant.	Brand	Model Name	Antenna Type	Connector	Gain (dBi)	NOTE
A	N/A	N/A	PIFA	N/A	-1.50	WIFI/BT Antenna

2.2 DESCRIPTION OF TEST MODES

To investigate the maximum EMI emission characteristics generates from EUT, the test system was pre-scanning tested base on the consideration of following EUT operation mode or test configuration mode which possible have effect on EMI emission level. Each of these EUT operation mode(s) or test configuration mode(s) mentioned above was evaluated respectively.

Pretest Mode	Description
Mode 1	802.11n-HT20 CH36/ CH40/ CH48
Mode 2	802.11-HT40 CH38/ CH46
Mode 3	802.11a CH36/ CH40/ CH48
Mode 4	Link Mode

For Conducted Emission	
Final Test Mode	Description
Mode 4	Link Mode

For Radiated Emission	
Final Test Mode	Description
Mode 1	802.11n-HT20 CH36/ CH40/ CH48
Mode 2	802.11-HT40 CH38/ CH46
Mode 3	802.11n CH36/ CH40/ CH48
Mode4	Link Mode

Note:

- (1) The measurements are performed at the highest, middle, lowest available channels.
- (2) The measurements are performed at all Bit Rate of Transmitter, the worst data was reported

2.3 BLOCK DIGRAM SHOWING THE CONFIGURATION OF SYSTEM TESTED

Conducted Emission Test

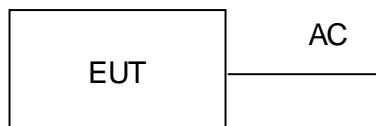

Radiated Spurious Emission Test

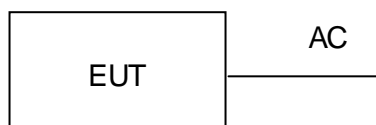

2.4 DESCRIPTION OF SUPPORT UNITS(CONDUCTED MODE)

The EUT has been tested as an independent unit together with other necessary accessories or support units. The following support units or accessories were used to form a representative test configuration during the tests.

Item	Equipment	Mfr/Brand	Model/Type No.	Series No.	Note

Item	Shielded Type	Ferrite Core	Length	Note

Note:

- (1) The support equipment was authorized by Declaration of Confirmation.
- (2) For detachable type I/O cable should be specified the length in cm in 『Length』 column.

2.5 EQUIPMENTS LIST FOR ALL TEST ITEMS

FOR RADIATED EMISSION TEST (BELOW 1GHZ)

Name of Equipment	Manufacturer	Model	Serial No.	Last Cal.	Next Cal.
EMI Test Receiver	Rohde & Schwarz	ESCI	101417	July 4, 2015	July 3, 2016
Trilog Broadband Antenna (25M-1GHz)	SCHWARZBECK	VULB9160	9160-3355	July 4, 2015	July 3, 2016
Signal Amplifier	SCHWARZBECK	BBV 9475	9745-0013	July 4, 2015	July 3, 2016
RF Cable	SCHWARZBECK	AK9515E	96221	July 4, 2015	July 3, 2016
3m Anechoic Chamber	CHENGYU	966	PTS-001	June 6, 2015	June 5, 2016
MULTI-DEVICE Positioning Controller	Max-Full	MF-7802	MF780208339	N/A	N/A
Active loop antenna (9K-30MHz)	Schwarzbeck	FMZB1519	1519-038	June 6, 2015	June 5, 2016
Spectrum analyzer	Agilent	E4407B	MY46185649	June 6, 2015	June 5, 2016

FOR RADIATED EMISSION TEST (1GHZ ABOVE)

Name of Equipment	Manufacturer	Model	Serial No.	Last Cal.	Next Cal.
EMI Test Receiver	Rohde & Schwarz	ESCI	101417	July 4, 2015	July 3, 2016
Horn Antenna (1G-18GHz)	SCHWARZBECK	BBHA9120D	9120D-1246	July 11, 2015	July 10, 2016
Spectrum Analyzer	Agilent	E4411B	MY4511453	July 4, 2015	July 3, 2016
Signal Amplifier	SCHWARZBECK	BBV 9718	9718-269	July 7, 2015	July 6, 2016
RF Cable	SCHWARZBECK	AK9515H	96220	July 8, 2015	July 7, 2016
3m Anechoic Chamber	CHENGYU	966	PTS-001	June 6, 2015	June 5, 2016
MULTI-DEVICE Positioning Controller	Max-Full	MF-7802	MF780208339	N/A	N/A
Horn Ant (18G-40GHz)	Schwarzbeck	BBHA 9170	9170-181	June 6, 2015	June 5, 2016

DongGuan Precise Testing Service Co., Ltd.

Building D, Baoding Technology Park, Guangming Road 2, Guangming Community, Dongcheng District, Dongguan, Guangdong, China

Tel: 86-769-23368601

Fax: 86-769-23368602

[http:// www.pts-testing.com](http://www.pts-testing.com)

- Note:** 1. The calibration interval of the above test instruments is 12 months and the calibrations are traceable to CEPREI/CHINA and NIM/CHINA
 2. N/A = No Calibration Request.

FOR CONDUCTED EMISSION TEST:

Name of Equipment	Manufacturer	Model	Serial No.	Last Cal.	Next Cal.
EMI Test Receiver	Rohde & Schwarz	ESCI	101417	July 4, 2015	July 3, 2016
Signal analyzer	Agilent	N9020A	MY51550378	July 8, 2015	July 7, 2016
Signal analyzer	Agilent	E4407B	MY3486729	June 6, 2015	June 5, 2016
Artificial Mains Network	Narda	L2-16B	000WX31025	July 8, 2015	July 7, 2016
Artificial Mains Network (AUX)	Narda	L2-16B	000WX31026	July 8, 2015	July 7, 2016
RF Cable	SCHWARZBECK	AK9515E	96222	July 4, 2015	July 3, 2016
Shielded Room	CHENGYU	843	PTS-002	June 6, 2015	June 5, 2016
Power Meter	Rohde & Schwarz	NRVS	100432	June 6, 2015	June 5, 2016
Power Sensor	Rohde & Schwarz	NRV-Z51	10456	June 6, 2015	June 5, 2016
Power Sensor	Rohde & Schwarz	NRV-Z32	10084	June 6, 2015	June 5, 2016

- Note:** 1. The calibration interval of the above test instruments is 12 months and the calibrations are traceable to CEPREI/CHINA and NIM/CHINA

DongGuan Precise Testing Service Co., Ltd.

Building D, Baoding Technology Park, Guangming Road 2, Guangming Community, Dongcheng District, Dongguan, Guangdong, China

Tel: 86-769-23368601

Fax: 86-769-23368602

[http:// www.pts-testing.com](http://www.pts-testing.com)

3. EMC EMISSION TEST

3.1 CONDUCTED EMISSION MEASUREMENT

3.1.1 POWER LINE CONDUCTED EMISSION Limits (Frequency Range 150KHz-30MHz)

FREQUENCY (MHz)	Class A (dBuV)		Class B (dBuV)		Standard
	Quasi-peak	Average	Quasi-peak	Average	
0.15 -0.5	79.00	66.00	66 - 56 *	56 - 46 *	CISPR
0.50 -5.0	73.00	60.00	56.00	46.00	CISPR
5.0 -30.0	73.00	60.00	60.00	50.00	CISPR

0.15 -0.5	79.00	66.00	66 - 56 *	56 - 46 *	FCC
0.50 -5.0	73.00	60.00	56.00	46.00	FCC
5.0 -30.0	73.00	60.00	60.00	50.00	FCC

Note:

- (1) The tighter limit applies at the band edges.
- (2) The limit of " * " marked band means the limitation decreases linearly with the logarithm of the frequency in the range.

The following table is the setting of the receiver

Receiver Parameters	Setting
Attenuation	10 dB
Start Frequency	0.15 MHz
Stop Frequency	30 MHz
IF Bandwidth	9 kHz

DongGuan Precise Testing Service Co., Ltd.

Building D, Baoding Technology Park, Guangming Road 2, Guangming Community, Dongcheng District, Dongguan, Guangdong, China

3.1.2 TEST PROCEDURE

- a. The EUT was placed 0.8 meters from the horizontal ground plane with EUT being connected to the power mains through a line impedance stabilization network (LISN). All other support equipments powered from additional LISN(s). The LISN provide 50 Ohm/ 50uH of coupling impedance for the measuring instrument.
- b. Interconnecting cables that hang closer than 40 cm to the ground plane shall be folded back and forth in the center forming a bundle 30 to 40 cm long.
- c. I/O cables that are not connected to a peripheral shall be bundled in the center. The end of the cable may be terminated, if required, using the correct terminating impedance. The overall length shall not exceed 1 m.
- d. LISN at least 80 cm from nearest part of EUT chassis.
- e. For the actual test configuration, please refer to the related Item –EUT Test Photos.

3.1.3 DEVIATION FROM TEST STANDARD

No deviation

3.1.4 TEST SETUP

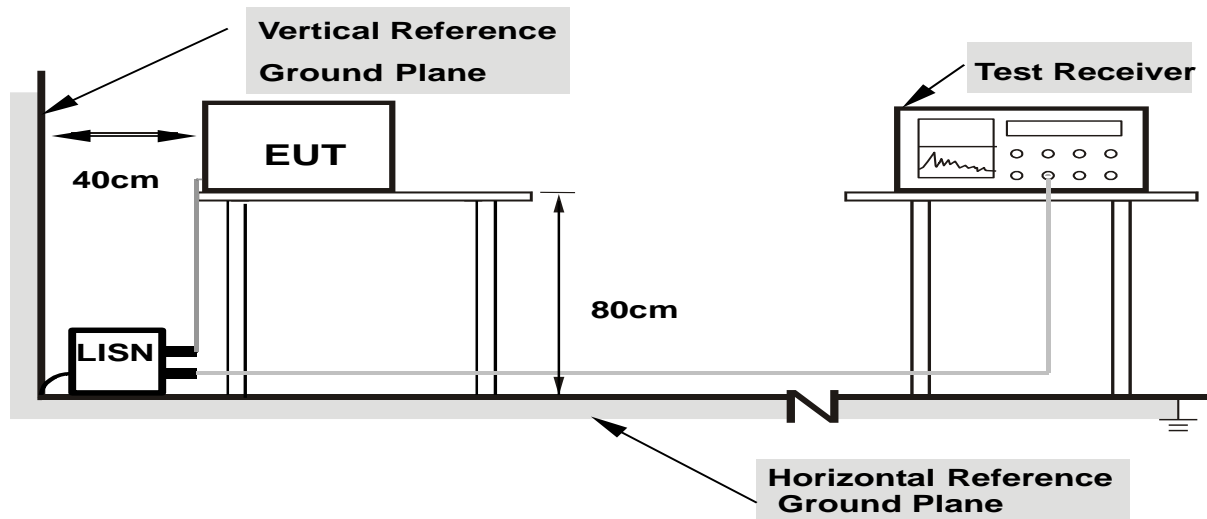

- Note: 1.Support units were connected to second LISN.**
2.Both of LISNs (AMN) are 80 cm from EUT and at least 80 from other units and other metal planes

3.1.5 EUT OPERATING CONDITIONS

The EUT was configured for testing in a typical fashion (as a customer would normally use it). The EUT has been programmed to continuously transmit during test. This operating condition was tested and used to collect the included data.

3.1.6 TEST RESULTS

EUT :	Glasses Free 3D Gaming Tablets	Model Name. :	X300
Temperature :	26 °C	Relative Humidity :	54%
Pressure :	1010hPa	Phase :	L
Test Voltage :	AC120V/60Hz	Test Mode :	Mode 4

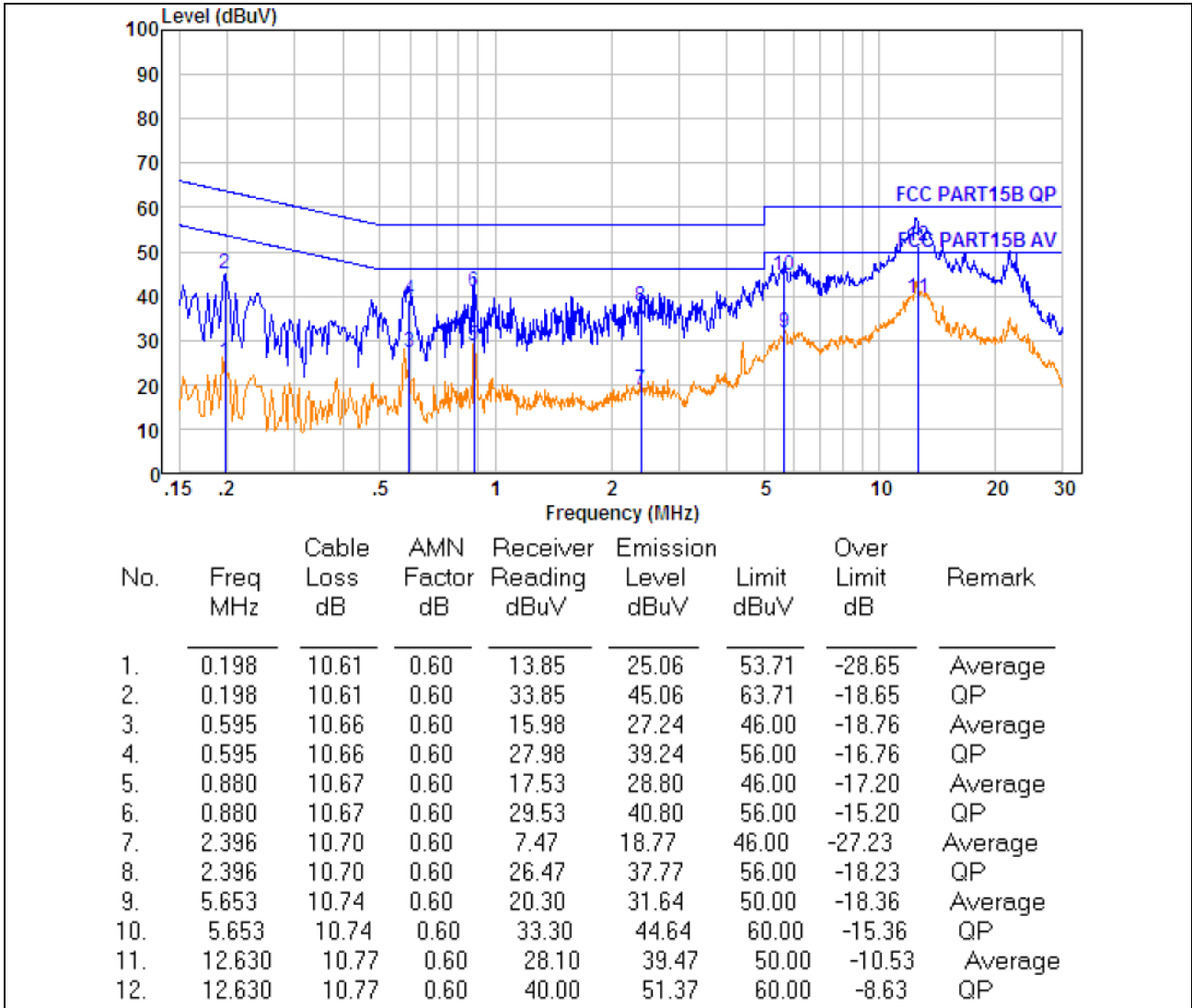

DongGuan Precise Testing Service Co., Ltd.

Building D, Baoding Technology Park, Guangming Road 2, Guangming Community, Dongcheng District, Dongguan, Guangdong, China

EUT :	Glasses Free 3D Gaming Tablets	Model Name. :	X300
Temperature :	26 °C	Relative Humidity :	54%
Pressure :	1010hPa	Phase :	N
Test Voltage :	AC120V/60Hz	Test Mode :	Mode 4

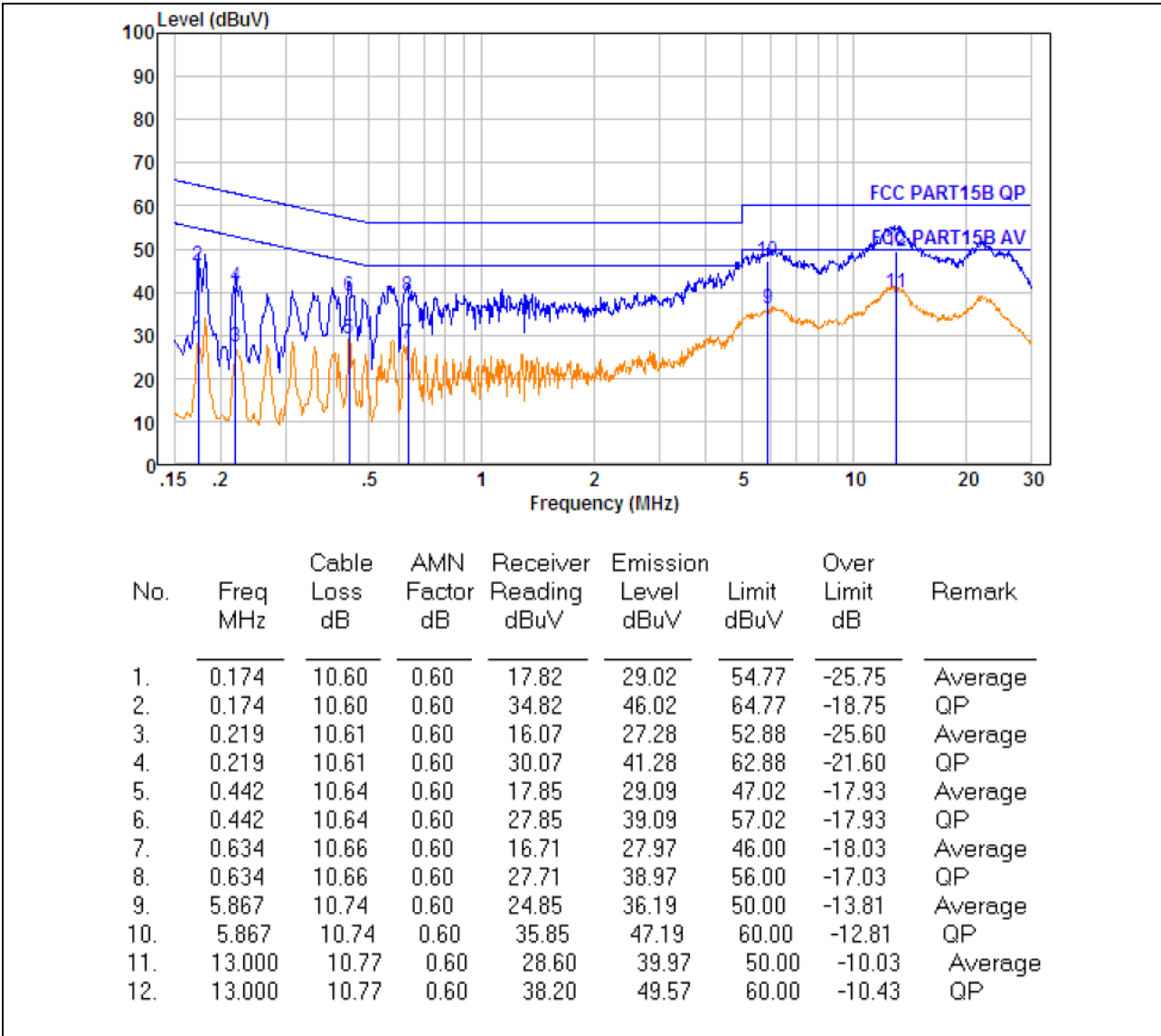

DongGuan Precise Testing Service Co., Ltd.

Building D, Baoding Technology Park, Guangming Road 2, Guangming Community, Dongcheng District, Dongguan, Guangdong, China

Tel: 86-769-23368601

Fax: 86-769-23368602

http:// www.pts-testing.com

EUT :	Glasses Free 3D Gaming Tablets	Model Name. :	X300
Temperature :	26 °C	Relative Humidity :	54%
Pressure :	1010hPa	Phase :	L
Test Voltage :	AC 240V/50Hz	Test Mode :	Mode 4

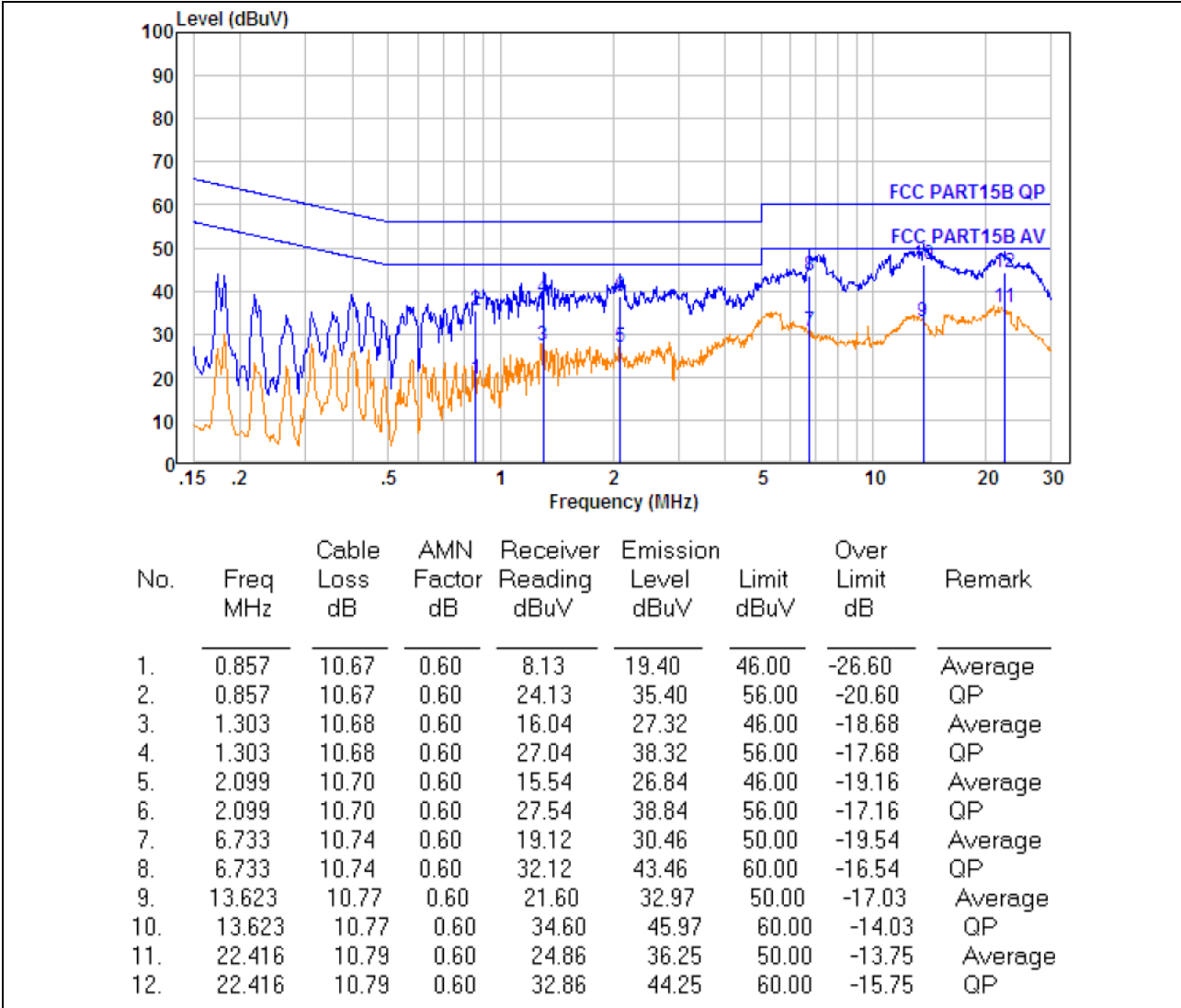

DongGuan Precise Testing Service Co., Ltd.

Building D, Baoding Technology Park, Guangming Road 2, Guangming Community, Dongcheng District, Dongguan, Guangdong, China

Tel: 86-769-23368601

Fax: 86-769-23368602

http:// www.pts-testing.com

EUT :	Glasses Free 3D Gaming Tablets	Model Name. :	X300
Temperature :	26 °C	Relative Humidity :	54%
Pressure :	1010hPa	Phase :	N
Test Voltage :	AC 240V/50Hz	Test Mode :	Mode 4

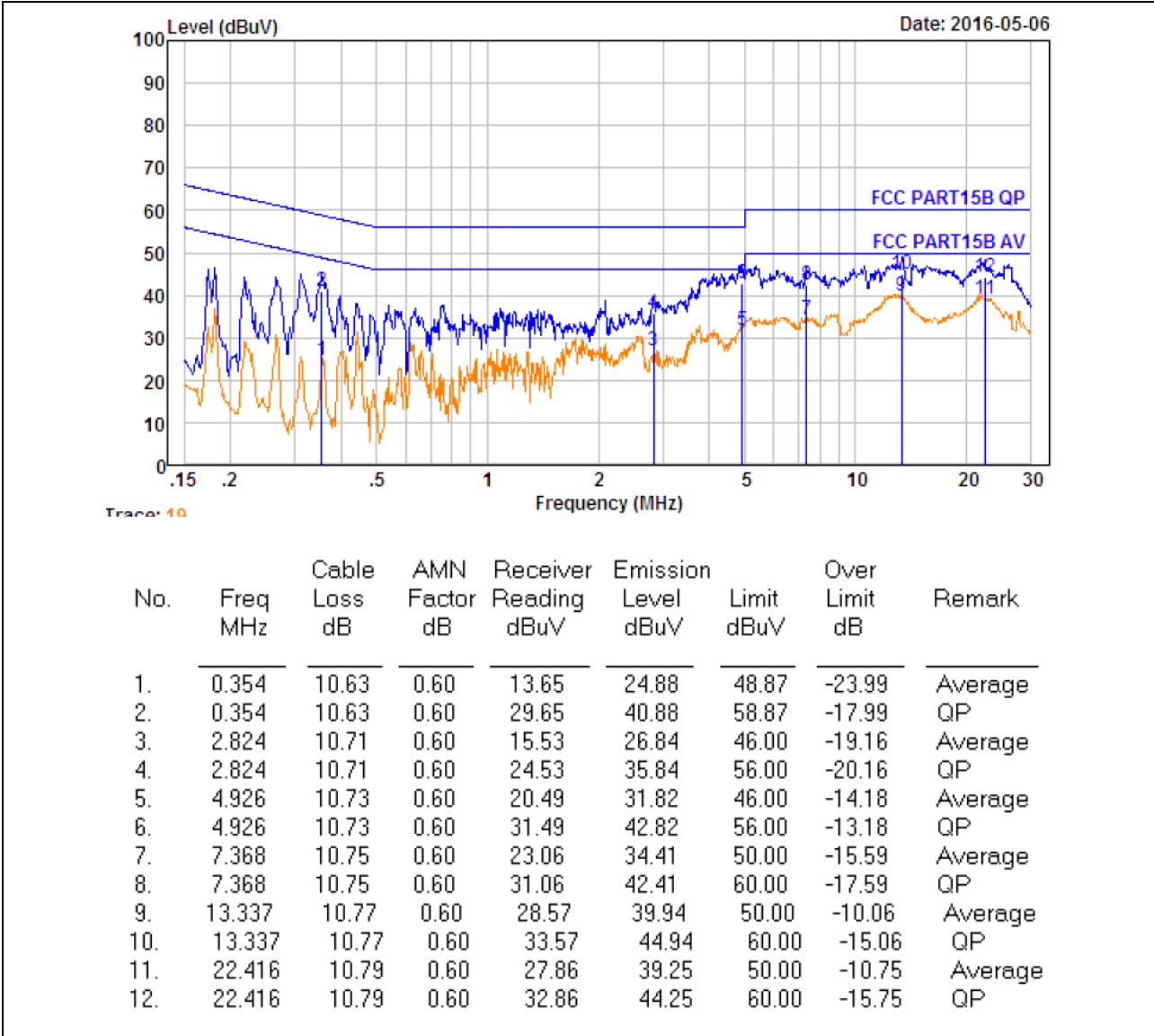

DongGuan Precise Testing Service Co., Ltd.

Building D, Baoding Technology Park, Guangming Road 2, Guangming Community, Dongcheng District, Dongguan, Guangdong, China

Tel: 86-769-23368601

Fax: 86-769-23368602

http:// www.pts-testing.com

3.2 RADIATED EMISSION MEASUREMENT

3.2.1 RADIATED EMISSION LIMITS (Frequency Range 9kHz-1000MHz)

20dBc in any 100 kHz bandwidth outside the operating frequency band. In case the emission fall within the restricted band specified on 15.205(a), then the 15.209(a) limit in the table below has to be followed.

Frequencies (MHz)	Field Strength (microvolts/meter)	Measurement Distance (meters)
0.009~0.490	2400/F(KHz)	300
0.490~1.705	24000/F(KHz)	30
1.705~30.0	30	30
30~88	100	3
88~216	150	3
216~960	200	3
Above 960	500	3

LIMITS OF RADIATED EMISSION MEASUREMENT (Above 1000MHz)

FREQUENCY (MHz)	Class A (dBuV/m) (at 3M)		Class B (dBuV/m) (at 3M)	
	PEAK	AVERAGE	PEAK	AVERAGE
Above 1000	80	60	74	54

Notes:

- (1) The limit for radiated test was performed according to FCC PART 15C.
- (2) The tighter limit applies at the band edges.
- (3) Emission level (dBuV/m)=20log Emission level (uV/m).

Spectrum Parameter	Setting
Attenuation	Auto
Start Frequency	1000 MHz
Stop Frequency	10th carrier harmonic
RB / VB (emission in restricted band)	1 MHz / 1 MHz for Peak, 1 MHz / 10Hz for Average

Receiver Parameter	Setting
Attenuation	Auto
Start ~ Stop Frequency	9kHz~150kHz / RB 200Hz for QP/AVG
Start ~ Stop Frequency	150kHz~30MHz / RB 9kHz for QP/AVG
Start ~ Stop Frequency	30MHz~1000MHz / RB 120kHz for QP

DongGuan Precise Testing Service Co., Ltd.

Building D, Baoding Technology Park, Guangming Road 2, Guangming Community, Dongcheng District, Dongguan, Guangdong, China

3.2.2 TEST PROCEDURE

- a. The measuring distance of at 3 m shall be used for measurements at frequency up to 1GHz. For frequencies above 1GHz, any suitable measuring distance may be used.
- b. The EUT was placed on the top of a rotating table 0.8 meters above the ground at a 3 meter open area test site. The table was rotated 360 degrees to determine the position of the highest radiation.
- c. The height of the equipment or of the substitution antenna shall be 0.8 m; the height of the test antenna shall vary between 1 m to 4 m. Both horizontal and vertical polarizations of the antenna are set to make the measurement.
- d. The initial step in collecting conducted emission data is a spectrum analyzer peak detector mode pre-scanning the measurement frequency range. Significant peaks are then marked and then Quasi Peak detector mode re-measured.
- e. If the Peak Mode measured value compliance with and lower than Quasi Peak Mode Limit, the EUT shall be deemed to meet QP Limits and then no additional QP Mode measurement performed.
- f. For the actual test configuration, please refer to the related Item –EUT Test Photos.

Note:

Both horizontal and vertical antenna polarities were tested and performed pretest to three orthogonal axis. The worst case emissions were reported

3.2.3 DEVIATION FROM TEST STANDARD

No deviation

3.2.4 TEST SETUP

(A) Radiated Emission Test-Up Frequency Below 30MHz

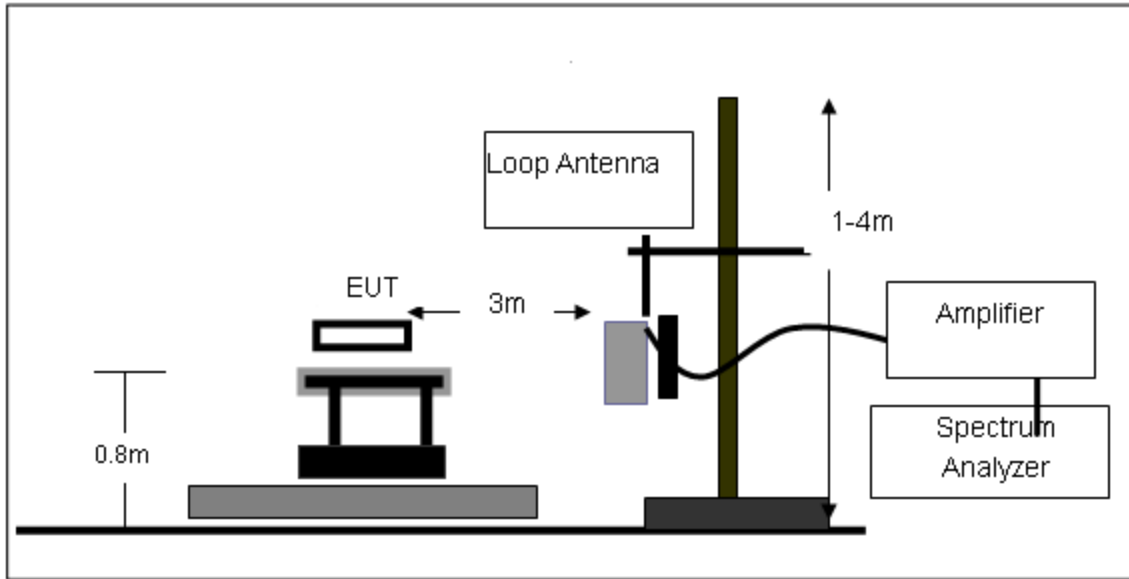

(B) Radiated Emission Test-Up Frequency 30MHz~1GHz

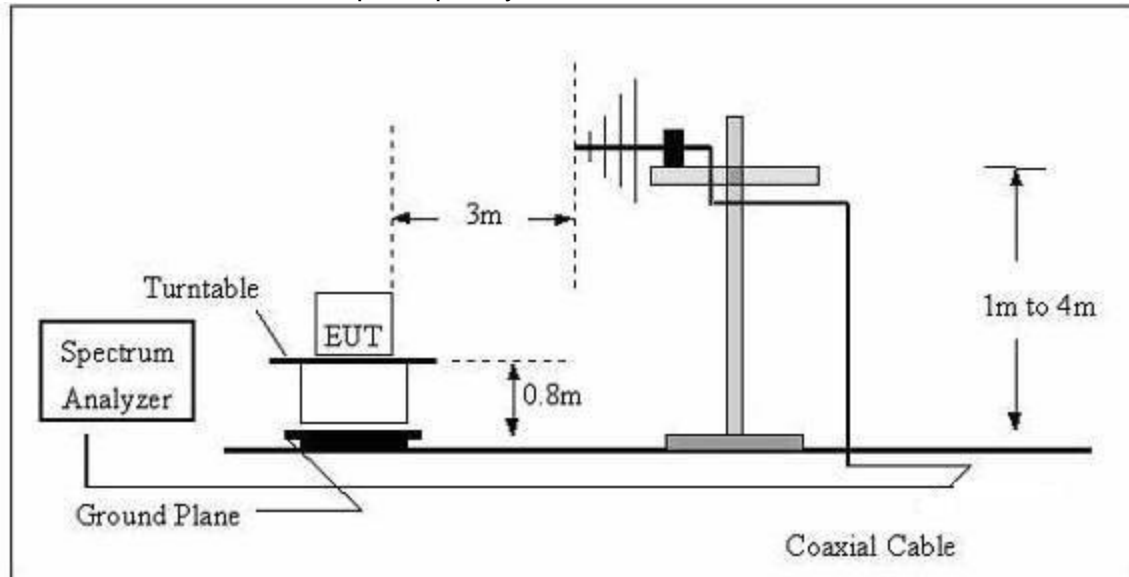

(C) Radiated Emission Test-Up Frequency Above 1GHz

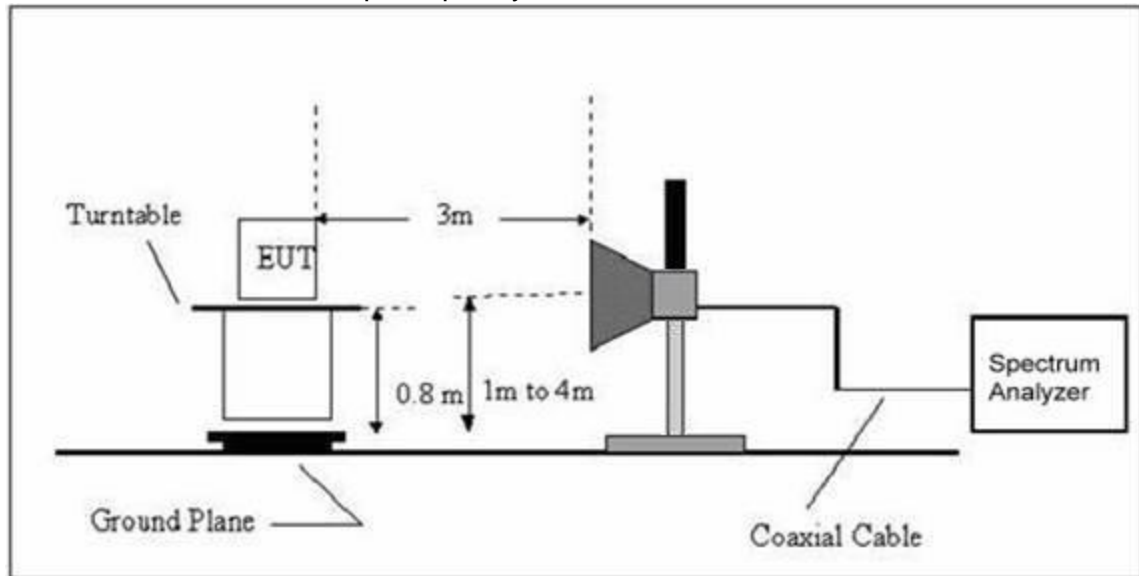

3.2.5 EUT OPERATING CONDITIONS

The EUT tested system was configured as the statements of 2.4 Unless otherwise a special operating condition is specified in the follows during the testing.

3.2.6 TEST RESULTS (BETWEEN 9KHZ – 30 MHZ)

EUT:	Glasses Free 3D Gaming Tablets	Model Name. :	X300
Temperature:	20 °C	Relative Humidity:	48%
Pressure:	1010 hPa	Test Voltage :	DC 3.80V
Test Mode :	TX	Polarization :	--

Freq. (MHz)	Reading (dBuV/m)	Limit (dBuV/m)	Margin (dB)	State P/F
--	--	--	--	PASS
--	--	--	--	PASS

NOTE:

The amplitude of spurious emissions which are attenuated by more than 20dB below the permissible value has no need to be reported.

Distance extrapolation factor = $40 \log(\text{specific distance}/\text{test distance})$ (dB);

Limit line = specific limits(dBuv) + distance extrapolation factor.

3.2.7 TEST RESULTS (BETWEEN 30MHZ – 1GHZ)

EUT :	Glasses Free 3D Gaming Tablets	Model Name. :	X300
Temperature :	20 °C	Relative Humidity:	48%
Pressure:	1010 hPa	Test Voltage :	DC 3.80V
Test Mode :	Mode 1		

Test plot for Horizontal:

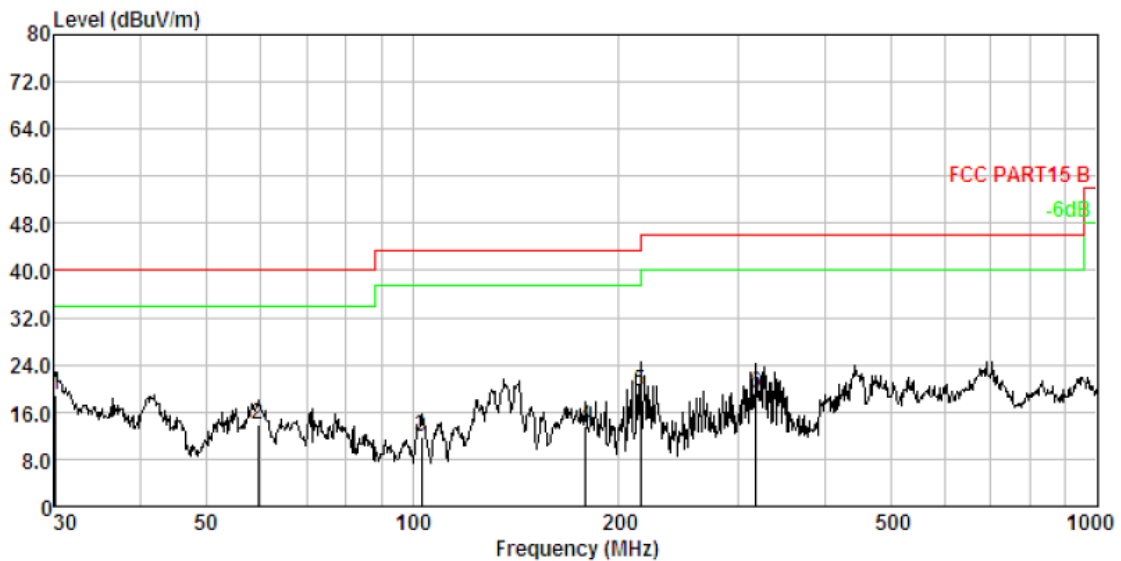

No.	Freq MHz	Cable Loss dB	ANT Factor dB/m	Receiver Reading dBUV	Preamp Factor dB	Emission Level dBUV/m	Limit dBUV/m	Over Limit dB	Remark
1.	30.105	1.06	13.24	34.49	29.97	18.82	40.00	-21.18	QP
2.	59.441	1.67	12.14	30.32	30.21	13.92	40.00	-26.08	QP
3.	103.080	2.17	10.50	29.49	30.40	11.76	43.50	-31.74	QP
4.	179.386	2.67	12.49	29.07	30.59	13.64	43.50	-29.86	QP
5.	215.268	2.84	10.67	36.53	30.66	19.38	43.50	-24.12	QP
6.	317.701	3.19	13.60	33.32	30.79	19.32	46.00	-26.68	QP

Remark:

Absolute Level= ReadingLevel+ Factor, Margin= Limit- Absolute Level

Test plot for Vertical:

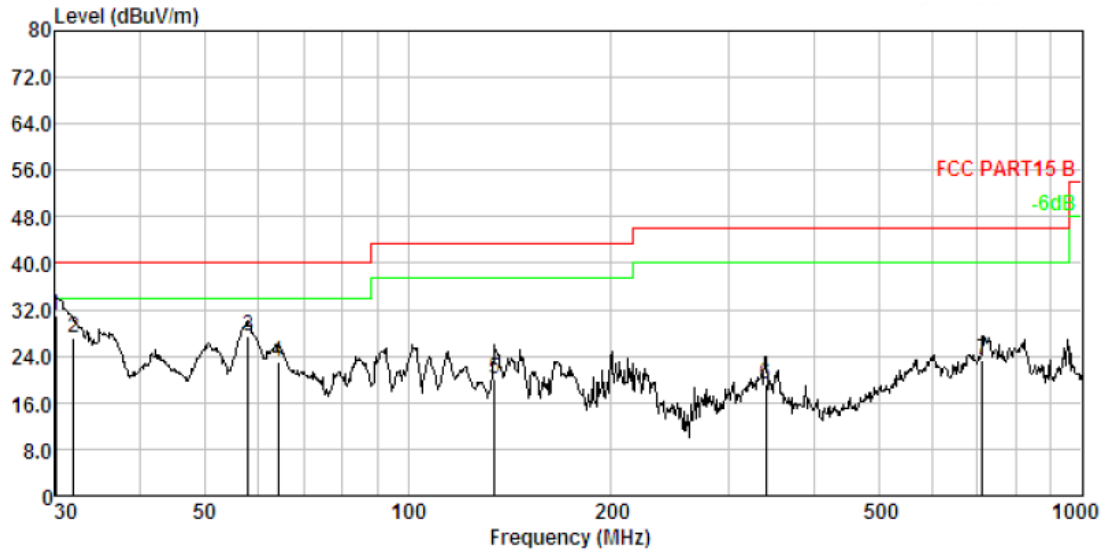

No.	Freq MHz	Cable Loss dB	ANT Factor dB/m	Receiver Reading dBuV	Preamplifier Factor dB	Emission Level dBuV/m	Limit dBuV/m	Over Limit dB	Remark
1.	30.000	1.06	13.24	46.65	29.97	30.98	40.00	-9.02	QP
2.	31.955	1.11	13.22	42.84	29.99	27.18	40.00	-12.82	QP
3.	57.999	1.65	12.06	43.81	30.20	27.32	40.00	-12.68	QP
4.	64.208	1.74	11.89	39.52	30.23	22.92	40.00	-17.08	QP
5.	134.559	2.41	12.97	35.07	30.49	19.96	43.50	-23.54	QP
6.	339.589	3.25	14.08	32.52	30.81	19.04	46.00	-26.96	QP
7.	711.674	3.92	20.36	30.25	31.07	23.46	46.00	-22.54	QP

Remark:

Absolute Level= ReadingLevel+ Factor, Margin= Limit- Absolute Level

3.2.8 TEST RESULTS (ABOVE 1000 MHZ)

802.11a

Normal Voltage

Polar (H/V)	Frequency	Meter Reading	Factor	Emission Level	Limits	Margin	Detector Type
	(GHz)	(dBuV)	(dB)	(dBuV/m)	(dBuV/m)	(dB)	
operation frequency:5180							
V	15.55	59.99	-3.75	56.24	74.00	-17.76	Pk
V	15.55	44.31	-3.75	40.56	54.00	-13.44	AV
H	15.55	61.08	-3.75	57.33	74.00	-16.67	Pk
H	15.55	44.99	-3.75	41.24	54.00	-12.76	AV
Remark:							
Absolute Level= ReadingLevel+ Factor, Margin= Limit- Absolute Level							

802.11a

Normal Voltage

Polar (H/V)	Frequency	Meter Reading	Factor	Emission Level	Limits	Margin	Detector Type
	(GHz)	(dBuV)	(dB)	(dBuV/m)	(dBuV/m)	(dB)	
operation frequency:5200							
V	15.65	60.13	-3.77	56.36	74.00	-17.64	Pk
V	15.65	44.49	-3.77	40.72	54.00	-13.28	AV
H	15.65	61.31	-3.77	57.54	74.00	-16.46	Pk
H	15.65	45.66	-3.77	41.89	54.00	-12.11	AV
Remark:							
Absolute Level= ReadingLevel+ Factor, Margin= Limit- Absolute Level							

802.11a

Normal Voltage

Polar (H/V)	Frequency	Meter Reading	Factor	Emission Level	Limits	Margin	Detector Type
	(GHz)	(dBuV)	(dB)	(dBuV/m)	(dBuV/m)	(dB)	
operation frequency:5240							
V	15.73	60.00	-3.78	56.22	74.00	-17.78	Pk
V	15.73	44.13	-3.78	40.35	54.00	-13.65	AV
H	15.73	61.67	-3.78	57.89	74.00	-16.11	Pk
H	15.73	45.02	-3.78	41.24	54.00	-12.76	AV
Remark:							
Absolute Level= ReadingLevel+ Factor, Margin= Limit- Absolute Level							

802.11n(20MHz)

Normal Voltage

Polar (H/V)	Frequency	Meter Reading	Factor	Emission Level	Limits	Margin	Detector Type
	(GHz)	(dBuV)	(dB)	(dBuV/m)	(dBuV/m)	(dB)	
operation frequency:5180							
V	15.55	60.48	-3.75	56.73	74.00	-17.27	Pk
V	15.55	42.86	-3.75	39.11	54.00	-14.89	AV
H	15.55	61.21	-3.75	57.46	74.00	-16.54	Pk
H	15.55	44.28	-3.75	40.53	54.00	-13.47	AV
Remark:							
Absolute Level= ReadingLevel+ Factor, Margin= Limit- Absolute Level							

802.11n(20MHz)

Normal Voltage

Polar (H/V)	Frequency	Meter Reading	Factor	Emission Level	Limits	Margin	Detector Type
	(GHz)	(dBuV)	(dB)	(dBuV/m)	(dBuV/m)	(dB)	
operation frequency:5200							
V	15.65	60.20	-3.77	56.43	74.00	-17.57	Pk
V	15.65	43.56	-3.77	39.79	54.00	-14.21	AV
H	15.65	61.02	-3.77	57.25	74.00	-16.75	Pk
H	15.65	43.01	-3.77	39.24	54.00	-14.76	AV
Remark:							
Absolute Level= ReadingLevel+ Factor, Margin= Limit- Absolute Level							

802.11n(20MHz)

Normal Voltage

Polar (H/V)	Frequency	Meter Reading	Factor	Emission Level	Limits	Margin	Detector Type
	(GHz)	(dBuV)	(dB)	(dBuV/m)	(dBuV/m)	(dB)	
operation frequency:5240							
V	15.73	60.61	-3.78	56.83	74.00	-17.17	Pk
V	15.73	43.23	-3.78	39.45	54.00	-14.55	AV
H	15.73	61.00	-3.78	57.22	74.00	-16.78	Pk
H	15.73	44.46	-3.78	40.68	54.00	-13.32	AV
Remark:							
Absolute Level= ReadingLevel+ Factor, Margin= Limit- Absolute Level							

802.11n(40MHz)

Normal Voltage

Polar (H/V)	Frequency	Meter Reading	Factor	Emission Level	Limits	Margin	Detector Type
	(GHz)	(dBuV)	(dB)	(dBuV/m)	(dBuV/m)	(dB)	
operation frequency:5190							
V	15.58	57.86	-3.75	54.11	74.00	-19.89	Pk
V	15.58	42.30	-3.75	38.55	54.00	-15.45	AV
H	15.58	60.17	-3.75	56.42	74.00	-17.58	Pk
H	15.58	42.99	-3.75	39.24	54.00	-14.76	AV
Remark:							
Absolute Level= ReadingLevel+ Factor, Margin= Limit- Absolute Level							

802.11n(40MHz)

Normal Voltage

Polar (H/V)	Frequency	Meter Reading	Factor	Emission Level	Limits	Margin	Detector Type
	(GHz)	(dBuV)	(dB)	(dBuV/m)	(dBuV/m)	(dB)	
operation frequency:5230							
V	15.69	58.22	-3.78	54.44	74.00	-19.56	Pk
V	15.69	42.70	-3.78	38.92	54.00	-15.08	AV
H	15.69	60.35	-3.78	56.57	74.00	-17.43	Pk
H	15.69	43.50	-3.78	39.72	54.00	-14.28	AV
Remark:							
Absolute Level= ReadingLevel+ Factor, Margin= Limit- Absolute Level							

Note:

Only worst mode is reported and 802.11n(20MHz) high channel have the worst result.

Results of Restricted Band Test:

802.11a

Normal Voltage

Polar (H/V)	Frequency	Meter Reading	Factor	Emission Level	Limits	Margin	Detector Type
	(MHz)	(dBuV)	(dB)	(dBuV/m)	(dBuV/m)	(dB)	
operation frequency:5180							
V	5150.00	54.91	-3.69	51.22	74.00	-22.78	Pk
V	5150.00	39.15	-3.69	35.46	54.00	-18.54	AV
H	5150.00	55.42	-3.69	51.73	74.00	-22.27	Pk
H	5150.00	38.94	-3.69	35.25	54.00	-18.75	AV
Remark:							
Absolute Level= ReadingLevel+ Factor, Margin= Limit- Absolute Level							

802.11a

Normal Voltage

Polar (H/V)	Frequency	Meter Reading	Factor	Emission Level	Limits	Margin	Detector Type
	(MHz)	(dBuV)	(dB)	(dBuV/m)	(dBuV/m)	(dB)	
operation frequency:5240							
V	5350.00	55.34	-3.71	51.63	74.00	-22.37	Pk
V	5350.00	39.58	-3.71	35.87	54.00	-18.13	AV
H	5350.00	54.96	-3.71	51.25	74.00	-22.75	Pk
H	5350.00	39.54	-3.71	35.83	54.00	-18.17	AV
Remark:							
Absolute Level= ReadingLevel+ Factor, Margin= Limit- Absolute Level							

Note: 1.All test modes have been tested and we only record the worst results.

2. Measuring frequencies from 9k~40GHz, No emission found between lowest internal used/generated frequency to 30MHz.

3. Radiated emissions measured in frequency range from 9k~40GHz were made with an instrument using Peak detector mode.

DongGuan Precise Testing Service Co., Ltd.

Building D, Baoding Technology Park, Guangming Road 2, Guangming Community, Dongcheng District, Dongguan, Guangdong, China

4. MAXIMUM CONDUCTED OUTPUT POWER

4.1 APPLIED PROCEDURES / LIMIT

For 5150~5250MHz

For an outdoor access point operating in the band 5.15-5.25 GHz, the maximum conducted output power over the frequency band of operation shall not exceed 1 W provided the maximum antenna gain does not exceed 6 dBi. In addition, the maximum power spectral density shall not exceed 17 dBm in any 1 megahertz band. If transmitting antennas of directional gain greater than 6 dBi are used, both the maximum conducted output power and the maximum power spectral density shall be reduced by the amount in dB that the directional gain of the antenna exceeds 6 dBi. The maximum e.i.r.p. at any elevation angle above 30 degrees as measured from the horizon must not exceed 125 mW (21 dBm).

4.2 TEST PROCEDURE

The transmitter output (antenna port) was connected to the power sensor. Read the test result from the power meter and record it.

4.3 DEVIATION FROM STANDARD

No deviation.

4.4 TEST SETUP



4.5 EUT OPERATION CONDITIONS

The EUT tested system was configured as the statements of 2.1 Unless otherwise a special operating condition is specified in the follows during the testing.

4.6 TEST RESULTS

EUT :	Glasses Free 3D Gaming Tablets	Model Name. :	X300
Temperature :	25 °C	Relative Humidity :	60%
Pressure :	1015 hPa	Test Voltage :	DC 3.80V

Test Mode	Channel	Frequency (MHz)	Max. AVG Power (dBm)	Max. Limit (dBm)	Result
802.11a	CH36	5180	12.05	30	Complies
	CH40	5200	12.23	30	Complies
	CH48	5240	12.51	30	Complies
802.11n (HT20)	CH36	5180	10.91	30	Complies
	CH40	5200	10.88	30	Complies
	CH48	5240	10.90	30	Complies
802.11n (HT40)	CH38	5190	8.94	30	Complies
	CH46	5230	9.14	30	Complies

NOTE: During the test the EUT is in 100% duty cycle transmitting.

5. POWER SPECTRAL DENSITY TEST

5.1 APPLIED PROCEDURES / LIMIT

The power spectral density is defined as the highest level of power in dBm per MHz generated by the transmitter within the power envelope. The power spectral density limits as show follow.

Frequency range(MHz)	Power Spectral Density Limit
5150~5250	17 dBm/MHz

5.2 TEST PROCEDURE

1. The transmitter was connected directly to a Spectrum Analyzer through a directional couple.
2. The power was monitored at the coupler port with a Spectrum Analyzer. The power level was set to the maximum level.
3. Set the RBW = 1000 kHz.
4. Set the VBW $\geq 3 \times$ RBW
5. Span=Encompass the entire emissions bandwidth (EBW) of the signal
6. Detector = peak.
7. Sweep time = auto couple.
8. Trace mode = max hold.
9. Allow trace to fully stabilize.
10. Use the peak marker function to determine the maximum power level in any 1MHz band segment within the fundamental EBW.

5.3 DEVIATION FROM STANDARD

No deviation.

5.4 TEST SETUP



5.5 EUT OPERATION CONDITIONS

The EUT tested system was configured as the statements of 2.4 Unless otherwise a special operating condition is specified in the follows during the testing.

5.6 TEST RESULTS

EUT :	Glasses Free 3D Gaming Tablets	Model Name. :	X300
Temperature :	25 °C	Relative Humidity :	60%
Pressure :	1012 hPa	Test Voltage :	DC 3.80V

Test Mode	Channel	Frequency (MHz)	Power Density (dBm/MHz)	Duty cycle factor (dB)	Sum Power Density (dBm/MHz)	Max. Limit (dBm/MHz)	Result
802.11a	CH36	5180	1.774	0	1.774	17	Complies
	CH40	5200	1.161	0	1.161	17	Complies
	CH48	5240	2.634	0	2.634	17	Complies
802.11n (HT20)	CH36	5180	1.409	0	1.409	17	Complies
	CH40	5200	1.800	0	1.800	17	Complies
	CH48	5240	1.478	0	1.478	17	Complies
802.11n (HT40)	CH38	5190	-2.067	0	-2.067	17	Complies
	CH46	5230	-0.716	0	-0.716	17	Complies

Duty cycle factor=10log(Ton/Tperiod)=10log[1/100%]dB= 0dB

DongGuan Precise Testing Service Co., Ltd.

Building D, Baoding Technology Park, Guangming Road 2, Guangming Community, Dongcheng District, Dongguan, Guangdong, China

Tel: 86-769-23368601

Fax: 86-769-23368602

http:// www.pts-testing.com

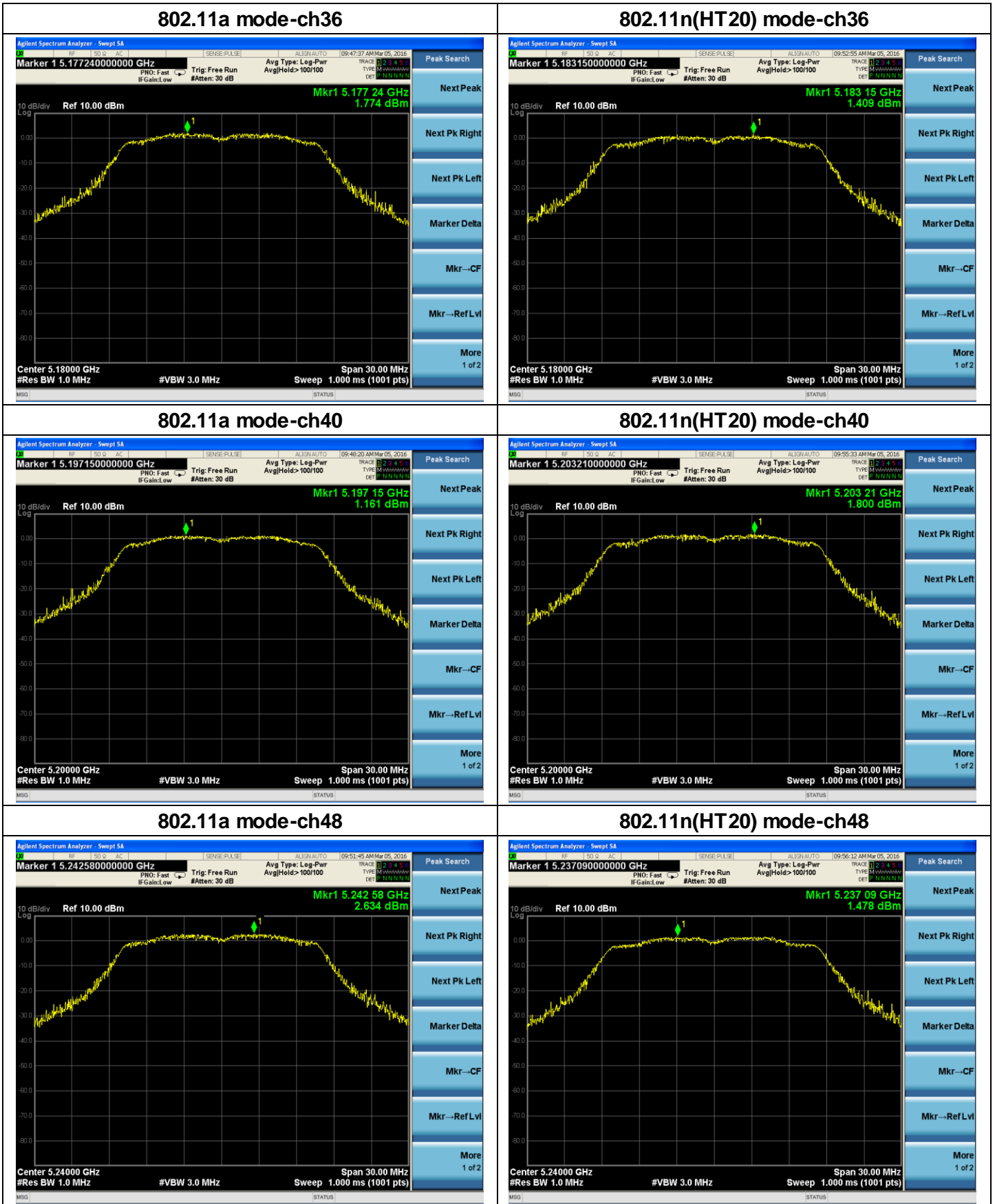

802.11n(HT40) mode-ch38

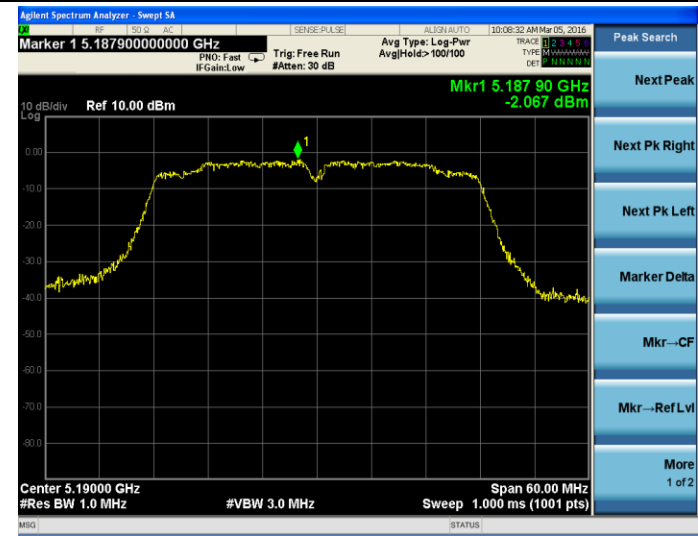

802.11n(HT40) mode-ch46

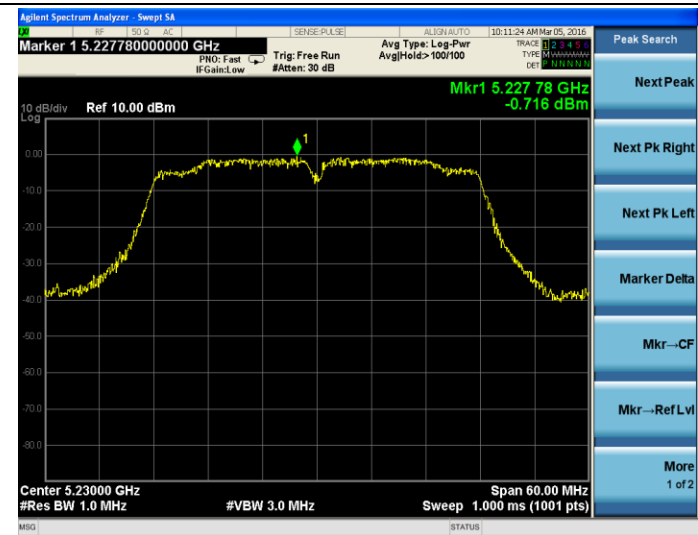

6. 99% AND 26DB OCCUPIED BANDWIDTH TEST

6.1 APPLIED PROCEDURES / LIMIT

No restriction limits. But resolution bandwidth within band edge measurement is 1% of the 99% occupied bandwidth.

6.2 TEST PROCEDURE

1. The transmitter output (antenna port) was connected to the spectrum analyser in peak hold mode.
2. The resolution bandwidth of 300 kHz and the video bandwidth of 1000 kHz were used.
3. Measured the spectrum width with power higher than 26dB below carrier.

6.3 DEVIATION FROM STANDARD

No deviation.

6.4 TEST SETUP



6.5 EUT OPERATION CONDITIONS

The EUT tested system was configured as the statements of 2.4 Unless otherwise a special operating condition is specified in the follows during the testing.

6.6 TEST RESULTS

EUT :	Glasses Free 3D Gaming Tablets	Model Name. :	X300
Temperature :	25 °C	Relative Humidity :	60%
Pressure :	1012 hPa	Test Voltage :	DC 3.80V

Test Mode	Channel	Frequency (MHz)	26dB Bandwidth (MHz)	99% Occupied Bandwidth (MHz)
802.11a	CH36	5180	21.21	16.684
	CH40	5200	21.20	16.678
	CH48	5240	21.22	16.678
802.11n (HT20)	CH36	5180	21.60	17.984
	CH40	5200	21.51	17.966
	CH48	5240	21.69	17.985
802.11n (HT40)	CH38	5190	40.47	36.673
	CH46	5230	40.33	36.583

DongGuan Precise Testing Service Co., Ltd.

Building D, Baoding Technology Park, Guangming Road 2, Guangming Community, Dongcheng District, Dongguan, Guangdong, China

802.11a mode-ch36

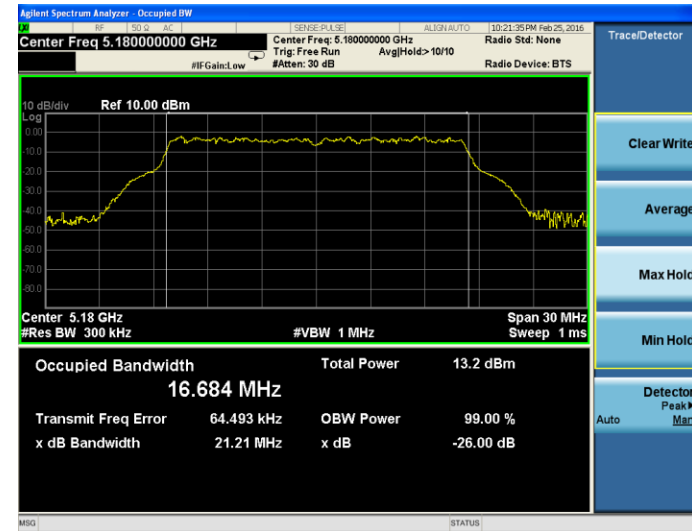

802.11n(HT20) mode-ch36

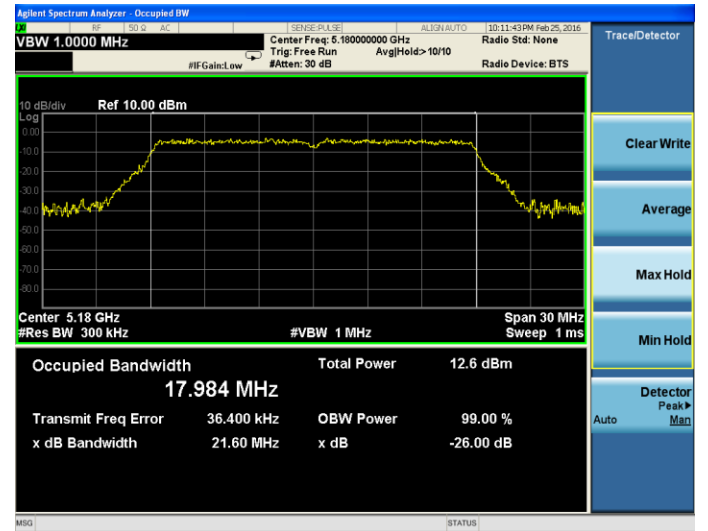

802.11a mode-ch40

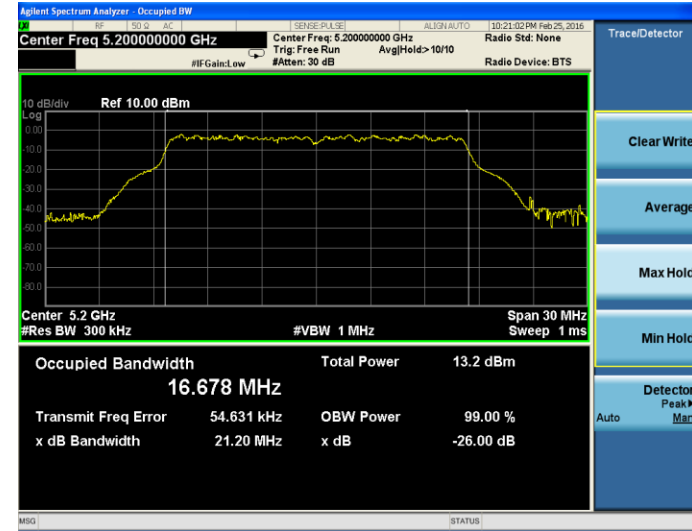

802.11n(HT20) mode-ch40

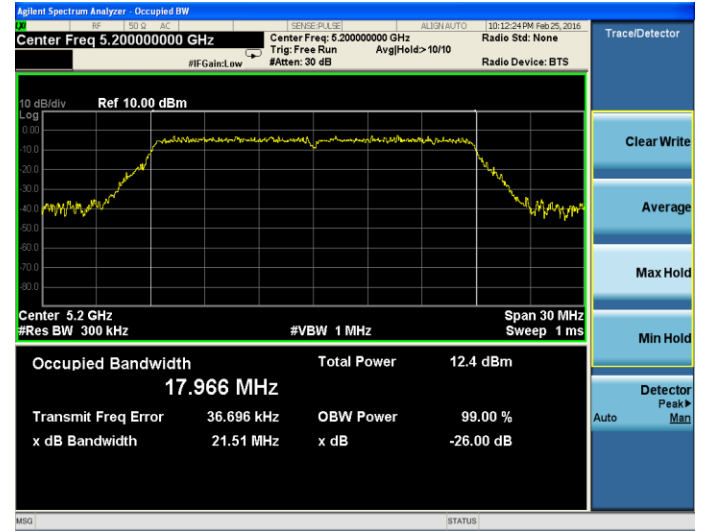

802.11a mode-ch48

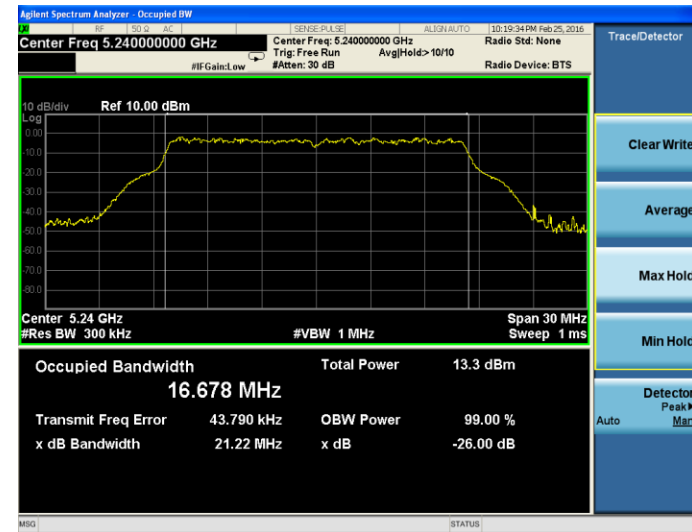

802.11n(HT20) mode-ch48

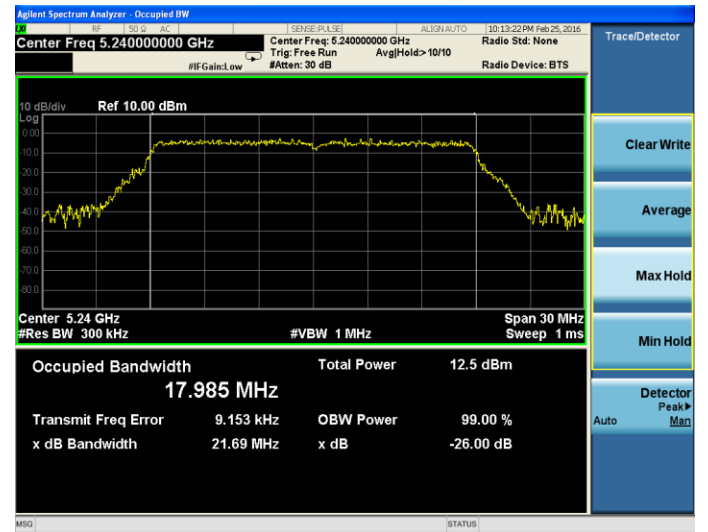

802.11n(HT40) mode-ch38

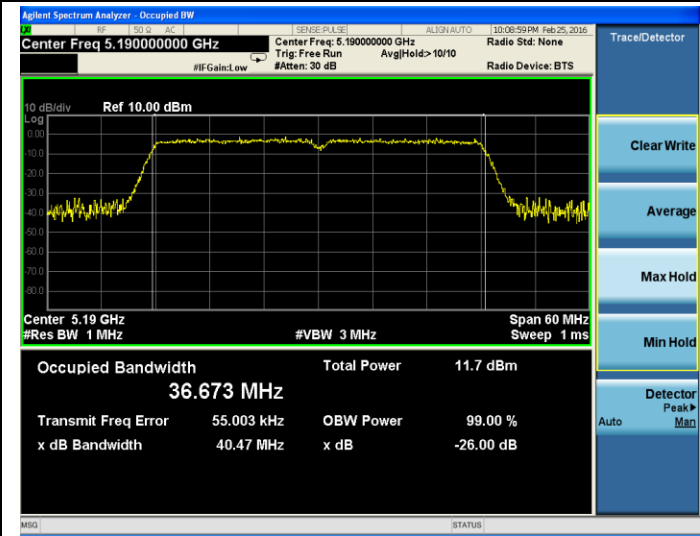

802.11n(HT40) mode-ch46

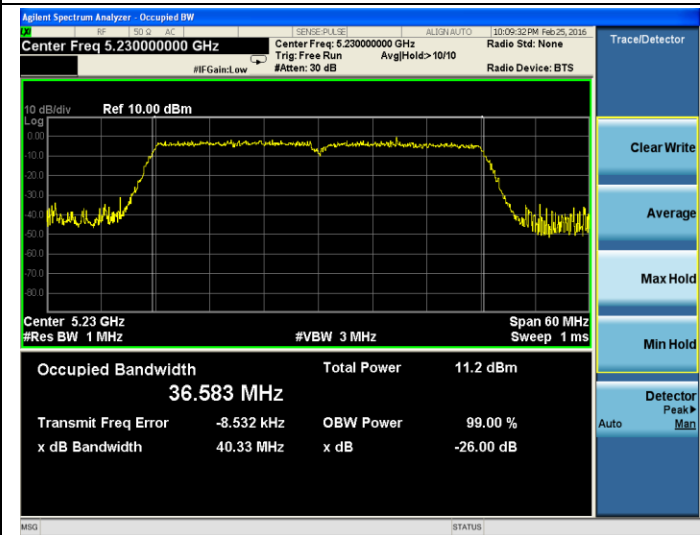

7. ANTENNA REQUIREMENT

7.1 STANDARD REQUIREMENT

15.203 requirement: For intentional device, according to 15.203: an intentional radiator shall be designed to ensure that no antenna other than that furnished by the responsible party shall be used with the device.

7.2 EUT ANTENNA

The EUT antenna is PIFA antenna and the gain is -1.50dBi. It's permanent attached antenna. It comply with the standard requirement.

8. EUT TEST PHOTO

Radiated Measurement Photos

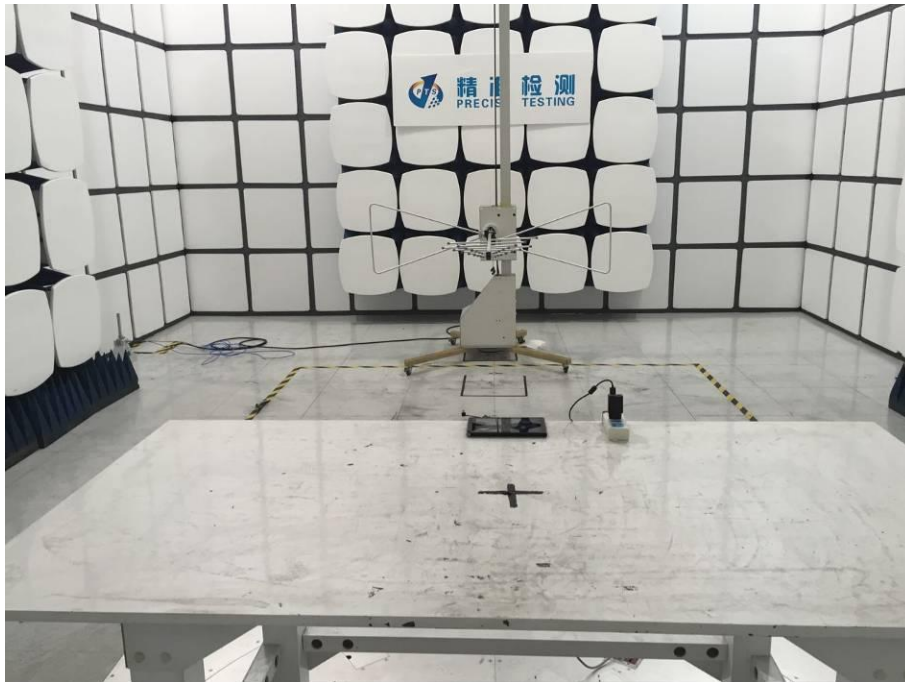

Radiated Measurement Photos

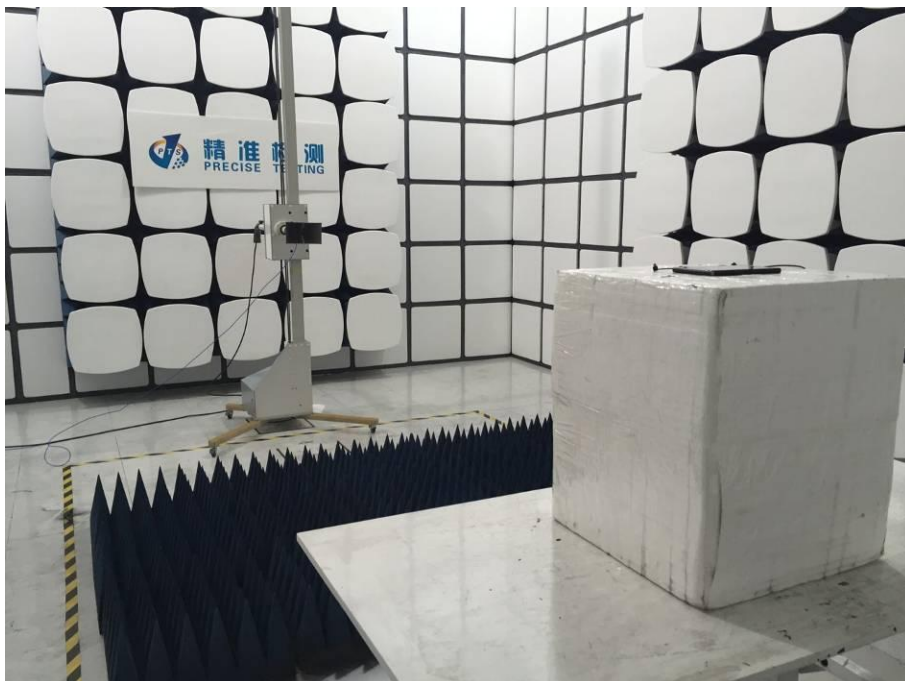

DongGuan Precise Testing Service Co., Ltd.

Building D, Baoding Technology Park, Guangming Road 2, Guangming Community, Dongcheng District, Dongguan, Guangdong, China

Tel: 86-769-23368601

Fax: 86-769-23368602

[http:// www.pts-testing.com](http://www.pts-testing.com)

Conducted Measurement Photos

