

# FCC TEST REPORT

## FCC ID: RWCRX300

Product : Glasses Free 3D Gaming Tablets

Model Name : X300

Brand : Morphus

Report No. : PT800196151217E-FC01

### Prepared for

AIKUN(CHINA) ELECTRONICS COMPANY LIMITED  
A2 BUILDING, LIANHE INDUSTRIAL PARK, FENGTANG ROAD, FUYONG TOWN,  
SHENZHEN, CHINA

### Prepared by

DongGuan Precise Testing Service Co.,Ltd.  
Building D, Baoding Technology Park, Guangming Road 2, Guangming Community  
Dongcheng District, Dongguan, Guangdong, China

### TEST RESULT CERTIFICATION

Applicant's name : AIKUN(CHINA) ELECTRONICS COMPANY LIMITED  
Address : A2 BUILDING, LIANHE INDUSTRIAL PARK, FENGTANG ROAD,  
FUYONG TOWN, SHENZHEN, CHINA  
Manufacture's name : AIKUN(CHINA) ELECTRONICS COMPANY LIMITED  
Address : A2 BUILDING, LIANHE INDUSTRIAL PARK, FENGTANG ROAD,  
FUYONG TOWN, SHENZHEN, CHINA  
Product name : Glasses Free 3D Gaming Tablets  
Model name : X300  
Standards : FCC CFR47 Part 15 Section 15.247  
Test procedure : ANSI C63.10:2013  
Test Date : Dec. 22, 2015 - May. 10, 2016  
Date of Issue : May. 10, 2016  
Test Result : Pass

This device described above has been tested by PTS, and the test results show that the equipment under test (EUT) is in compliance with the FCC requirements. And it is applicable only to the tested sample identified in the report.

This report shall not be reproduced except in full, without the written approval of PTS, this document may be altered or revised by PTS, personal only, and shall be noted in the revision of the document.

Testing Engineer

August Qiu



Technical Manager

Hack Ye

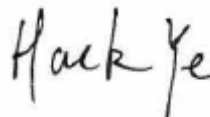

Authorized Signatory

Chris Du



**DongGuan Precise Testing Service Co., Ltd.**

Building D, Baoding Technology Park, Guangming Road 2, Guangming Community, Dongcheng District, Dongguan, Guangdong, China

Tel: 86-769-23368601

Fax: 86-769-23368602

[http:// www.pts-testing.com](http://www.pts-testing.com)

**Table of Contents**

	<b>Page</b>
<b>1 . SUMMARY OF TEST RESULTS</b>	<b>5</b>
1.1 TEST FACILITY	6
1.2 MEASUREMENT UNCERTAINTY	6
<b>2 . GENERAL INFORMATION</b>	<b>7</b>
2.1 GENERAL DESCRIPTION OF EUT	7
2.2 DESCRIPTION OF TEST MODES	9
2.3 BLOCK DIGRAM SHOWING THE CONFIGURATION OF SYSTEM TESTED	10
2.4 EQUIPMENTS LIST FOR ALL TEST ITEMS	11
FOR RADIATED EMISSION TEST (BELOW 1GHZ)	11
FOR RADIATED EMISSION TEST (1GHZ ABOVE)	11
<b>3 . EMC EMISSION TEST</b>	<b>13</b>
3.1 CONDUCTED EMISSION MEASUREMENT	13
3.1.1 POWER LINE CONDUCTED EMISSION LIMITS	13
3.1.2 TEST PROCEDURE	14
3.1.3 DEVIATION FROM TEST STANDARD	14
3.1.4 TEST SETUP	14
3.1.5 EUT OPERATING CONDITIONS	14
3.1.6 TEST RESULTS	15
3.2 RADIATED EMISSION MEASUREMENT	19
3.2.1 RADIATED EMISSION LIMITS	19
3.2.2 TEST PROCEDURE	20
3.2.3 DEVIATION FROM TEST STANDARD	20
3.2.4 TEST SETUP	21
3.2.5 EUT OPERATING CONDITIONS	22
3.2.6 TEST RESULTS (BETWEEN 9KHZ – 30 MHZ)	23
3.2.7 TEST RESULTS (BETWEEN 30MHZ – 1GHZ)	24
3.2.8 TEST RESULTS (ABOVE 1000 MHZ)	26
<b>4 . POWER SPECTRAL DENSITY TEST</b>	<b>36</b>
4.1 APPLIED PROCEDURES / LIMIT	36
4.1.1 TEST PROCEDURE	36
4.1.2 DEVIATION FROM STANDARD	36
4.1.3 TEST SETUP	36
4.1.4 EUT OPERATION CONDITIONS	36

**DongGuan Precise Testing Service Co., Ltd.**

Building D, Baoding Technology Park, Guangming Road 2, Guangming Community, Dongcheng District, Dongguan, Guangdong, China

Tel: 86-769-23368601

Fax: 86-769-23368602

[http:// www.pts-testing.com](http://www.pts-testing.com)

<b>Table of Contents</b>		<b>Page</b>
4.1.5 TEST RESULTS		37
<b>5 . BANDWIDTH TEST</b>		<b>41</b>
5.1 APPLIED PROCEDURES / LIMIT		41
5.1.1 TEST PROCEDURE		41
5.1.2 DEVIATION FROM STANDARD		41
5.1.3 TEST SETUP		41
5.1.4 EUT OPERATION CONDITIONS		41
5.1.5 TEST RESULTS		42
<b>6 . PEAK OUTPUT POWER TEST</b>		<b>46</b>
6.1 APPLIED PROCEDURES / LIMIT		46
6.1.1 TEST PROCEDURE		46
6.1.2 DEVIATION FROM STANDARD		46
6.1.3 TEST SETUP		46
6.1.4 EUT OPERATION CONDITIONS		46
6.1.5 TEST RESULTS		47
<b>7 . CONDUCTED SPURIOUS EMISSIONS AND BAND EDGES TEST</b>		<b>48</b>
7.1 DEVIATION FROM STANDARD		49
7.2 TEST SETUP		49
7.3 EUT OPERATION CONDITIONS		49
7.4 TEST RESULTS FOR CONDUCTED SPURIOUS EMISSIONS TEST		49
7.5 TEST RESULTS FOR BAND EDGES TEST		53
<b>8 . ANTENNA REQUIREMENT</b>		<b>55</b>
8.1 STANDARD REQUIREMENT		55
8.2 EUT ANTENNA		55
<b>9 . EUT TEST PHOTO</b>		<b>56</b>
<b>APPENDIX-PHOTOGRAPHS OF EUT CONSTRUCTIONAL DETAILS</b>		

## 1. SUMMARY OF TEST RESULTS

Test procedures according to the technical standards:

FCC Part15 (15.247) , Subpart C			
Standard Section	Test Item	Judgment	Remark
15.207	Conducted Emission	PASS	
15.247 (a)(2)	6dB Bandwidth	PASS	
15.247 (b)	Peak Output Power	PASS	
15.247 (c)	Radiated Spurious Emission	PASS	
15.247 (d)	Power Spectral Density	PASS	
15.205	Band Edge Emission	PASS	
15.203	Antenna Requirement	PASS	

**NOTE:**

(1) "N/A" denotes test is not applicable in this Test Report

**DongGuan Precise Testing Service Co., Ltd.**

Building D, Baoding Technology Park, Guangming Road 2, Guangming Community, Dongcheng District, Dongguan, Guangdong, China

Tel: 86-769-23368601

Fax: 86-769-23368602

[http:// www.pts-testing.com](http://www.pts-testing.com)

## 1.1 TEST FACILITY

**FCC Registration No.: 371540, IC Registration No.: 12191A-1**

Dongguan Precise Testing Service Co., Ltd.

Add.: Building D, Baoding Technology Park, Guangming Road 2, Dongcheng District, Dongguan, Guangdong, China

## 1.2 MEASUREMENT UNCERTAINTY

The reported uncertainty of measurement  $y \pm U$  where expanded uncertainty  $U$  is based on a standard uncertainty multiplied by a coverage factor of  $k=2$  providing a level of confidence of approximately **95 %**.

No.	Item	Uncertainty
1	Conducted Emission Test	$\pm 1.38\text{dB}$
2	RF power, conducted	$\pm 0.16\text{dB}$
3	Spurious emissions, conducted	$\pm 0.21\text{dB}$
4	All emissions, radiated (<1G)	$\pm 4.68\text{dB}$
5	All emissions, radiated (>1G)	$\pm 4.89\text{dB}$
6	Temperature	$\pm 0.5^\circ\text{C}$
7	Humidity	$\pm 2\%$

**DongGuan Precise Testing Service Co., Ltd.**

Building D, Baoding Technology Park, Guangming Road 2, Guangming Community, Dongcheng District, Dongguan, Guangdong, China

Tel: 86-769-23368601

Fax: 86-769-23368602

[http:// www.pts-testing.com](http://www.pts-testing.com)

## 2. GENERAL INFORMATION

### 2.1 GENERAL DESCRIPTION OF EUT

Equipment	Glasses Free 3D Gaming Tablets
Trade Name	Morphus
Model Name	X300, RX300
Product Description	<p>Operation Frequency: 802.11b/g/n(HT20): 2412~2462 MHz; 802.11n(HT40): 2422~2452 MHz BE LE: 2402~2480MHz</p> <p>Modulation Type: 802.11b: DSSS(CCK,DQPSK,DBPSK) 802.11g: OFDM(64QAM, 16QAM, QPSK, BPSK) 802.11n: OFDM (64QAM, 16QAM, QPSK, BPSK) BT LE: GFSK</p> <p>Bit Rate of Transmitter 802.11b: 1-11Mbps 802.11g: 6-54Mbps 802.11n-HT20: 6.5-65 Mbps 802.11n-HT40:13.5-135 Mbps BT LE: 1Mbps</p> <p>Number Of Channel 802.11b/g/n20MHz:11CH 802.11n40MHz:7CH BT LE: 40CH</p> <p>Antenna Designation: Please see Note 3.</p> <p>Antenna Gain (dBi) -1.5dBi</p> <p>Based on the application, features, or specification exhibited in User's Manual, the EUT is considered as an ITE/Computing Device. More details of EUT technical specification, please refer to the User's Manual.</p>
Channel List:	Please refer to the Note 2.
Power supply:	DC 3.80V by battery Recharge voltage: DC 5V/2A
Connecting I/O Port(s)	Please refer to the User's Manual

### DongGuan Precise Testing Service Co., Ltd.

Building D, Baoding Technology Park, Guangming Road 2, Guangming Community, Dongcheng District, Dongguan, Guangdong, China

1. For a more detailed features description, please refer to the manufacturer's specifications or the User's Manual.

2.

Channel List for 802.11b/g/n(20)							
Channel	Frequency (MHz)	Channel	Frequency (MHz)	Channel	Frequency (MHz)	Channel	Frequency (MHz)
01	2412	04	2427	07	2442	10	2457
02	2417	05	2432	08	2447	11	2462
03	2422	06	2437	09	2452		

Channel List for 802.11b/g/n(20)							
Channel	Frequency (MHz)	Channel	Frequency (MHz)	Channel	Frequency (MHz)	Channel	Frequency (MHz)
01	--	04	2427	07	2442	10	--
02	--	05	2432	08	2447	11	--
03	2422	06	2437	09	2452		

Channel List for BT LE							
Channel	Frequency (MHz)	Channel	Frequency (MHz)	Channel	Frequency (MHz)	Channel	Frequency (MHz)
0	2402	10	2422	20	2442	30	2462
1	2404	11	2424	21	2444	31	2464
2	2406	12	2426	22	2446	32	2466
3	2408	13	2428	23	2448	33	2468
4	2410	14	2430	24	2450	34	2470
5	2412	15	2432	25	2452	35	2472
6	2414	16	2434	26	2454	36	2474
7	2416	17	2436	27	2456	37	2476
8	2418	18	2438	28	2458	38	2478
9	2420	19	2440	29	2460	39	2480

3.

Table for Filed Antenna

Ant.	Brand	Model Name	Antenna Type	Connector	Gain (dBi)	NOTE
A	N/A	N/A	PIFA	N/A	-1.50	WIFI/BT Antenna



## 2.2 DESCRIPTION OF TEST MODES

To investigate the maximum EMI emission characteristics generates from EUT, the test system was pre-scanning tested base on the consideration of following EUT operation mode or test configuration mode which possible have effect on EMI emission level. Each of these EUT operation mode(s) or test configuration mode(s) mentioned above was evaluated respectively.

Pretest Mode	Description
Mode 1	802.11b CH1/ CH6/ CH11
Mode 2	802.11g CH1/ CH6/ CH11
Mode 3	802.11n(HT20) CH1/ CH6/ CH11
Mode 4	802.11n(HT40) CH3/ CH6/ CH9
Mode 5	BT LE CH1/ CH20/ CH40
Mode 6	Link Mode

For Conducted Emission	
Final Test Mode	Description
Mode 6	Link Mode

For Radiated Emission	
Final Test Mode	Description
Mode 1	802.11b CH1/ CH6/ CH11
Mode 2	802.11g CH1/ CH6/ CH11
Mode 3	802.11n(HT20) CH1/ CH6/ CH11
Mode 4	802.11n(HT40) CH3/ CH6/ CH9
Mode 5	BT LE CH1/ CH20/ CH40
Mode 6	Link Mode

Note:

- (1) The measurements are performed at the highest, middle, lowest available channels.
- (2) The measurements are performed at all Bit Rate of Transmitter, the worst data was reported

## 2.3 BLOCK DIGRAM SHOWING THE CONFIGURATION OF SYSTEM TESTED

Conducted Emission Test

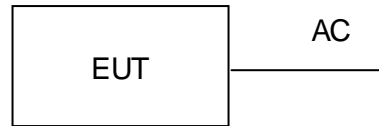

Radiated Spurious Emission Test

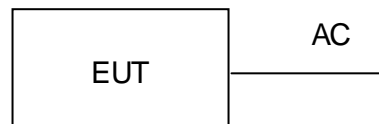

### 2.3.1 DESCRIPTION OF SUPPORT UNITS(CONDUCTED MODE)

The EUT has been tested as an independent unit together with other necessary accessories or support units. The following support units or accessories were used to form a representative test configuration during the tests.

Item	Equipment	Mfr/Brand	Model/Type No.	Series No.	Note

Item	Shielded Type	Ferrite Core	Length	Note

Note:

- (1) The support equipment was authorized by Declaration of Confirmation.
- (2) For detachable type I/O cable should be specified the length in cm in 「Length」 column.

## 2.4 EQUIPMENTS LIST FOR ALL TEST ITEMS

### FOR RADIATED EMISSION TEST (BELOW 1GHZ)

Name of Equipment	Manufacturer	Model	Serial No.	Last Cal.	Next Cal.
EMI Test Receiver	Rohde & Schwarz	ESCI	101417	July 4, 2	July 3, 2016
Trilog Broadband Antenna (25M-1GHz)	SCHWARZBECK	VULB9160	9160-3355	July 4, 2015	July 3, 2016
Signal Amplifier	SCHWARZBECK	BBV 9475	9745-0013	July 4, 2015	July 3, 2016
RF Cable	SCHWARZBECK	AK9515E	96221	July 4, 2015	July 3, 2016
3m Anechoic Chamber	CHENGYU	966	PTS-001	June 6, 2015	June 5, 2016
MULTI-DEVICE Positioning Controller	Max-Full	MF-7802	MF780208339	N/A	N/A
Active loop antenna (9K-30MHz)	Schwarzbeck	FMZB1519	1519-038	June 6, 2015	June 5, 2016
Spectrum analyzer	Agilent	E4407B	MY46185649	June 6, 2015	June 5, 2016

### FOR RADIATED EMISSION TEST (1GHZ ABOVE)

Name of Equipment	Manufacturer	Model	Serial No.	Last Cal.	Next Cal.
EMI Test Receiver	Rohde & Schwarz	ESCI	101417	July 4, 2015	July 3, 2016
Horn Antenna (1G-18GHz)	SCHWARZBECK	BBHA9120D	9120D-1246	July 11, 2015	July 10, 2016
Spectrum Analyzer	Agilent	E4411B	MY4511453	July 4, 2015	July 3, 2016
Signal Amplifier	SCHWARZBECK	BBV 9718	9718-269	July 7, 2015	July 6, 2016
RF Cable	SCHWARZBECK	AK9515H	96220	July 8, 2015	July 7, 2016
3m Anechoic Chamber	CHENGYU	966	PTS-001	June 6, 2015	June 5, 2016
MULTI-DEVICE Positioning Controller	Max-Full	MF-7802	MF780208339	N/A	N/A

### DongGuan Precise Testing Service Co., Ltd.

Building D, Baoding Technology Park, Guangming Road 2, Guangming Community, Dongcheng District, Dongguan, Guangdong, China

Tel: 86-769-23368601

Fax: 86-769-23368602

[http:// www.pts-testing.com](http://www.pts-testing.com)

Horn Ant (18G-40GHz)	Schwarzbeck	BBHA 9170	9170-181	June 6, 2015	June 5, 2016
-------------------------	-------------	-----------	----------	--------------	--------------

- Note:** 1. The calibration interval of the above test instruments is 12 months and the calibrations are traceable to CEPREI/CHINA and NIM/CHINA  
 2. N/A = No Calibration Request.

FOR CONDUCTED EMISSION TEST:

Name of Equipment	Manufacturer	Model	Serial No.	Last Cal.	Next Cal.
EMI Test Receiver	Rohde & Schwarz	ESCI	101417	July 4, 2015	July 3, 2016
Signal analyzer	Agilent	N9020A	MY51550378	July 8, 2015	July 7, 2016
Signal analyzer	Agilent	E4407B	MY3486729	June 6, 2015	June 5, 2016
Artificial Mains Network	Narda	L2-16B	000WX31025	July 8, 2015	July 7, 2016
Artificial Mains Network (AUX)	Narda	L2-16B	000WX31026	July 8, 2015	July 7, 2016
RF Cable	SCHWARZBECK	AK9515E	96222	July 4, 2015	July 3, 2016
Shielded Room	CHENGYU	843	PTS-002	June 6, 2015	June 5, 2016
Power Meter	Rohde & Schwarz	NRVS	100432	June 6, 2015	June 5, 2016
Power Sensor	Rohde & Schwarz	NRV-Z51	10456	June 6, 2015	June 5, 2016
Power Sensor	Rohde & Schwarz	NRV-Z32	10084	June 6, 2015	June 5, 2016

- Note:** 1. The calibration interval of the above test instruments is 12 months and the calibrations are traceable to CEPREI/CHINA and NIM/CHINA

**DongGuan Precise Testing Service Co., Ltd.**

Building D, Baoding Technology Park, Guangming Road 2, Guangming Community, Dongcheng District, Dongguan, Guangdong, China

Tel: 86-769-23368601

Fax: 86-769-23368602

[http:// www.pts-testing.com](http://www.pts-testing.com)

### 3. EMC EMISSION TEST

#### 3.1 CONDUCTED EMISSION MEASUREMENT

##### 3.1.1 POWER LINE CONDUCTED EMISSION Limits (Frequency Range 150KHz-30MHz)

FREQUENCY (MHz)	Class A (dBuV)		Class B (dBuV)		Standard
	Quasi-peak	Average	Quasi-peak	Average	
0.15 -0.5	79.00	66.00	66 - 56 *	56 - 46 *	CISPR
0.50 -5.0	73.00	60.00	56.00	46.00	CISPR
5.0 -30.0	73.00	60.00	60.00	50.00	CISPR

0.15 -0.5	79.00	66.00	66 - 56 *	56 - 46 *	FCC
0.50 -5.0	73.00	60.00	56.00	46.00	FCC
5.0 -30.0	73.00	60.00	60.00	50.00	FCC

Note:

- (1) The tighter limit applies at the band edges.
- (2) The limit of " \* " marked band means the limitation decreases linearly with the logarithm of the frequency in the range.

The following table is the setting of the receiver

Receiver Parameters	Setting
Attenuation	10 dB
Start Frequency	0.15 MHz
Stop Frequency	30 MHz
IF Bandwidth	9 kHz

#### DongGuan Precise Testing Service Co., Ltd.

Building D, Baoding Technology Park, Guangming Road 2, Guangming Community, Dongcheng District, Dongguan, Guangdong, China

### 3.1.2 TEST PROCEDURE

- a. The EUT was placed 0.8 meters from the horizontal ground plane with EUT being connected to the power mains through a line impedance stabilization network (LISN). All other support equipments powered from additional LISN(s). The LISN provide 50 Ohm/ 50uH of coupling impedance for the measuring instrument.
- b. Interconnecting cables that hang closer than 40 cm to the ground plane shall be folded back and forth in the center forming a bundle 30 to 40 cm long.
- c. I/O cables that are not connected to a peripheral shall be bundled in the center. The end of the cable may be terminated, if required, using the correct terminating impedance. The overall length shall not exceed 1 m.
- d. LISN at least 80 cm from nearest part of EUT chassis.
- e. For the actual test configuration, please refer to the related Item –EUT Test Photos.

### 3.1.3 DEVIATION FROM TEST STANDARD

No deviation

### 3.1.4 TEST SETUP

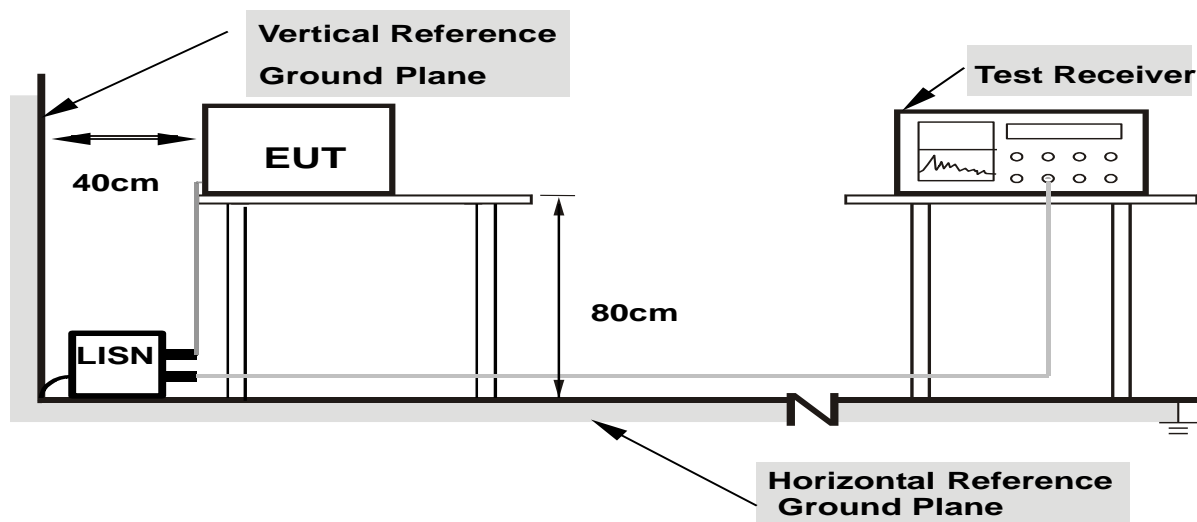

- Note: 1.Support units were connected to second LISN.**  
**2.Both of LISNs (AMN) are 80 cm from EUT and at least 80 from other units and other metal planes**

### 3.1.5 EUT OPERATING CONDITIONS

The EUT was configured for testing in a typical fashion (as a customer would normally use it). The EUT has been programmed to continuously transmit during test. This operating condition was tested and used to collect the included data.

**3.1.6 TEST RESULTS**

EUT :	Glasses Free 3D Gaming Tablets	Model Name. :	X300
Temperature :	26 °C	Relative Humidity :	54%
Pressure :	1010hPa	Phase :	L
Test Voltage :	AC120V/60Hz	Test Mode :	Mode 5

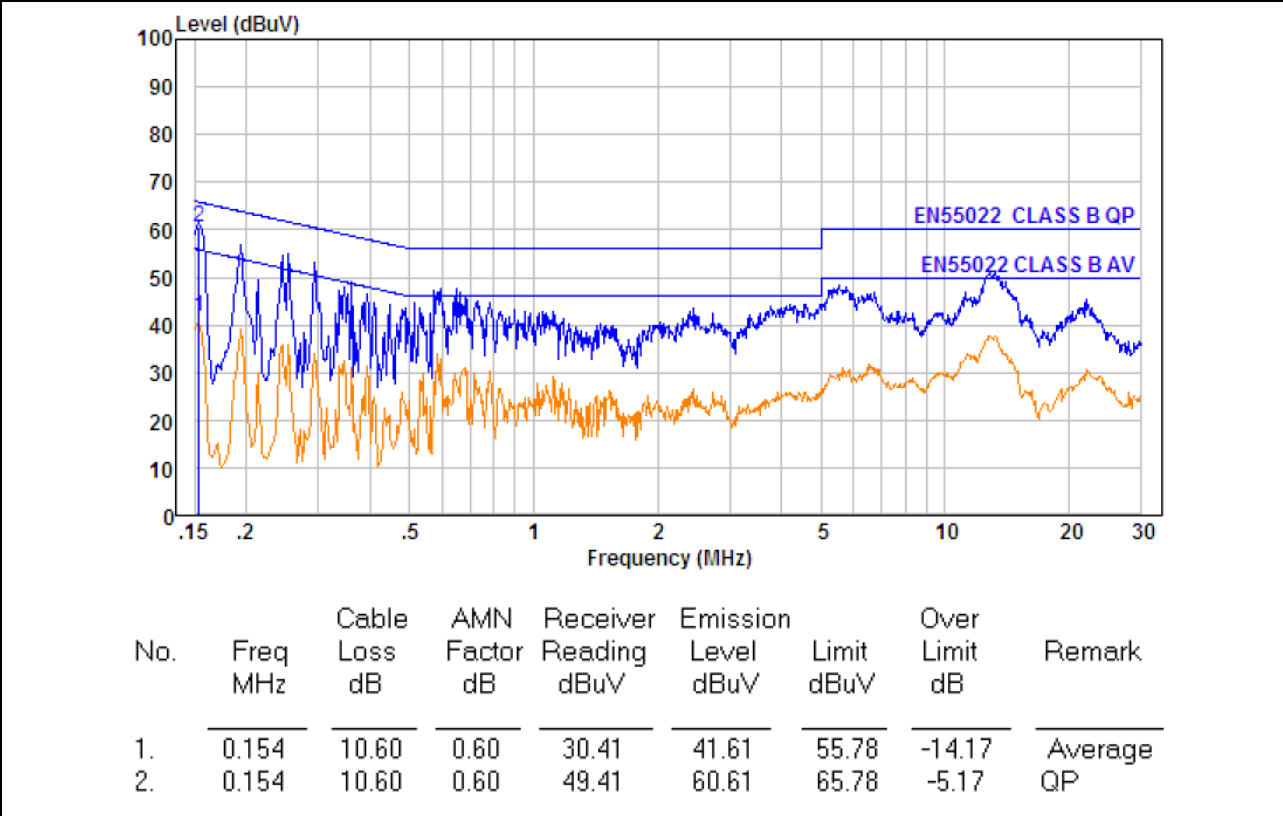

**DongGuan Precise Testing Service Co., Ltd.**

Building D, Baoding Technology Park, Guangming Road 2, Guangming Community, Dongcheng District, Dongguan, Guangdong, China

Tel: 86-769-23368601

Fax: 86-769-23368602

http:// www.pts-testing.com

EUT :	Glasses Free 3D Gaming Tablets	Model Name. :	X300
Temperature :	26 °C	Relative Humidity :	54%
Pressure :	1010hPa	Phase :	N
Test Voltage :	AC120V/60Hz	Test Mode :	Mode 5

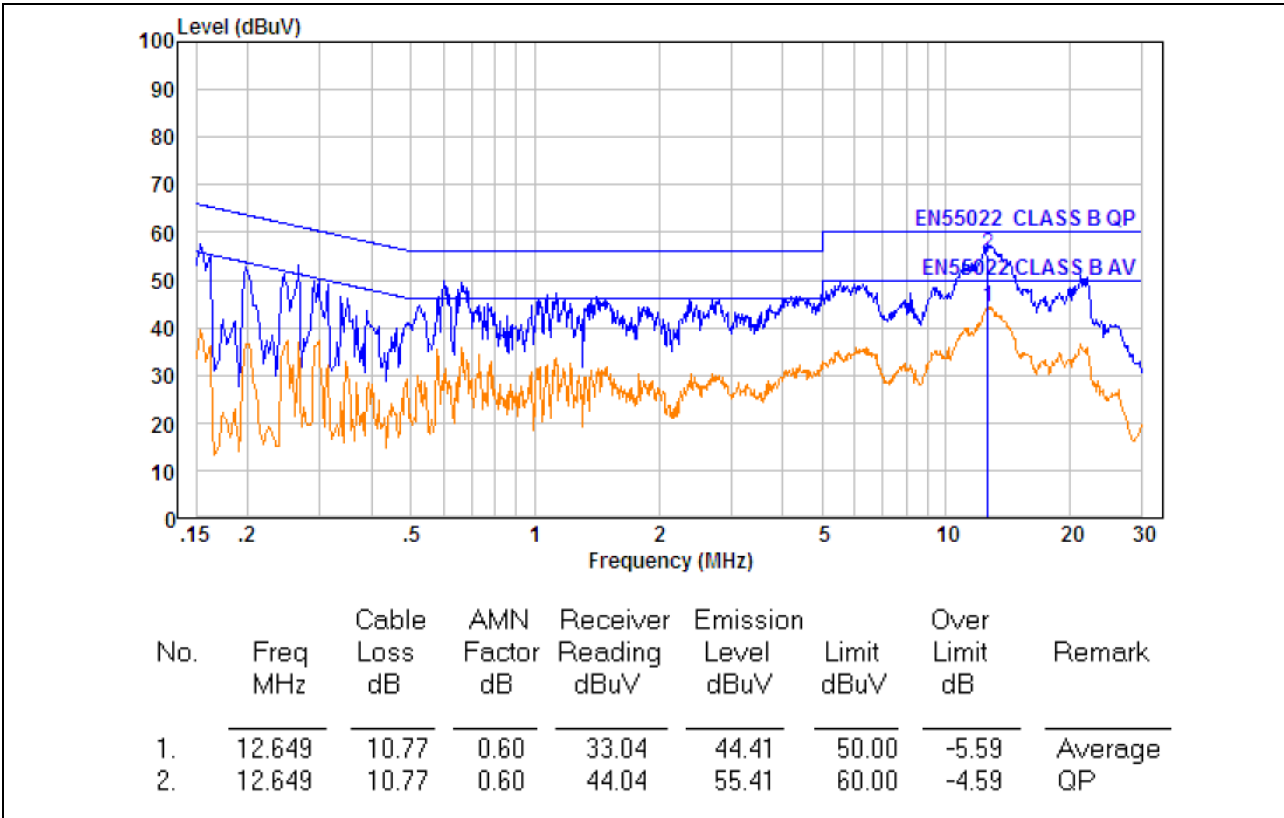

**DongGuan Precise Testing Service Co., Ltd.**

Building D, Baoding Technology Park, Guangming Road 2, Guangming Community, Dongcheng District, Dongguan, Guangdong, China

Tel: 86-769-23368601

Fax: 86-769-23368602

http:// www.pts-testing.com



EUT :	Glasses Free 3D Gaming Tablets	Model Name. :	X300
Temperature :	26 °C	Relative Humidity :	54%
Pressure :	1010hPa	Phase :	L
Test Voltage :	AC 240V/50Hz	Test Mode :	Mode 5

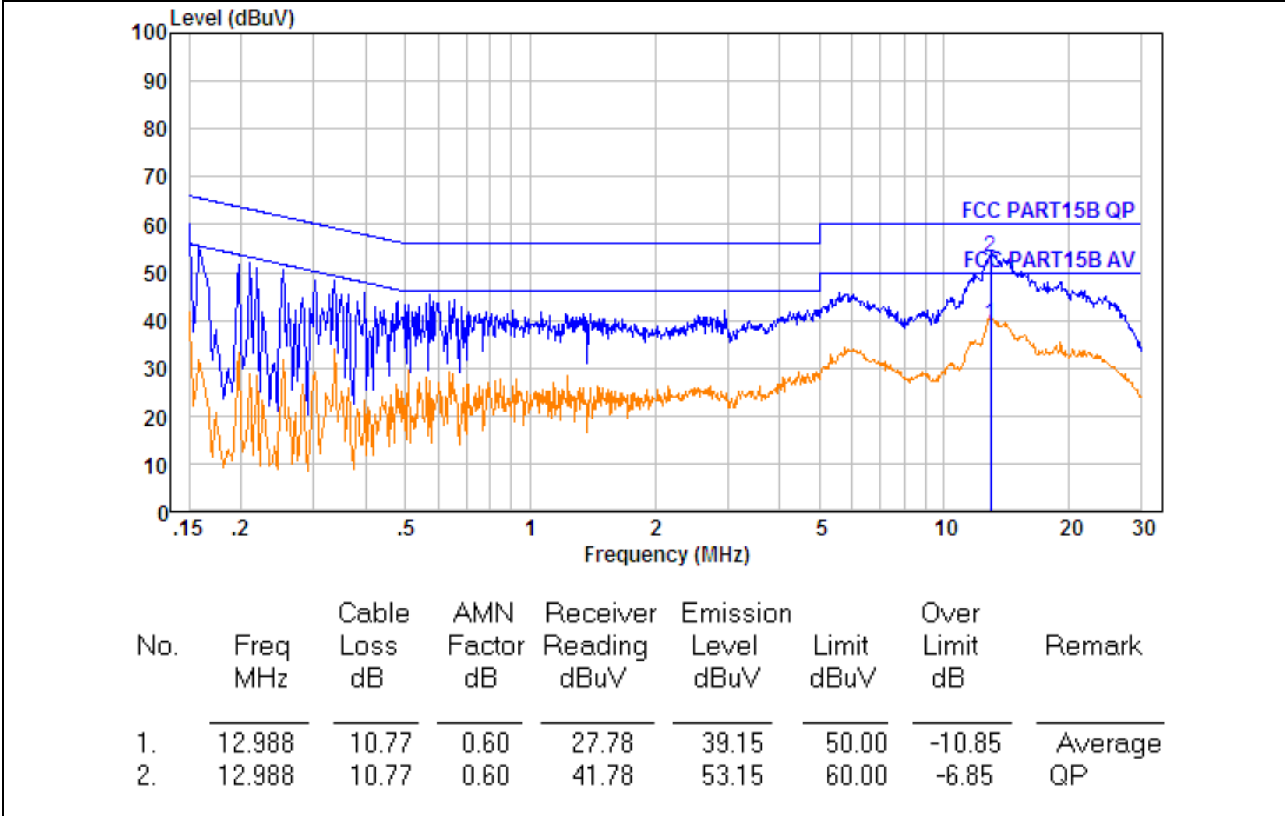

**DongGuan Precise Testing Service Co., Ltd.**

Building D, Baoding Technology Park, Guangming Road 2, Guangming Community, Dongcheng District, Dongguan, Guangdong, China

Tel: 86-769-23368601

Fax: 86-769-23368602

http:// www.pts-testing.com

EUT :	Glasses Free 3D Gaming Tablets	Model Name. :	X300
Temperature :	26 °C	Relative Humidity :	54%
Pressure :	1010hPa	Phase :	N
Test Voltage :	AC 240V/50Hz	Test Mode :	Mode 5

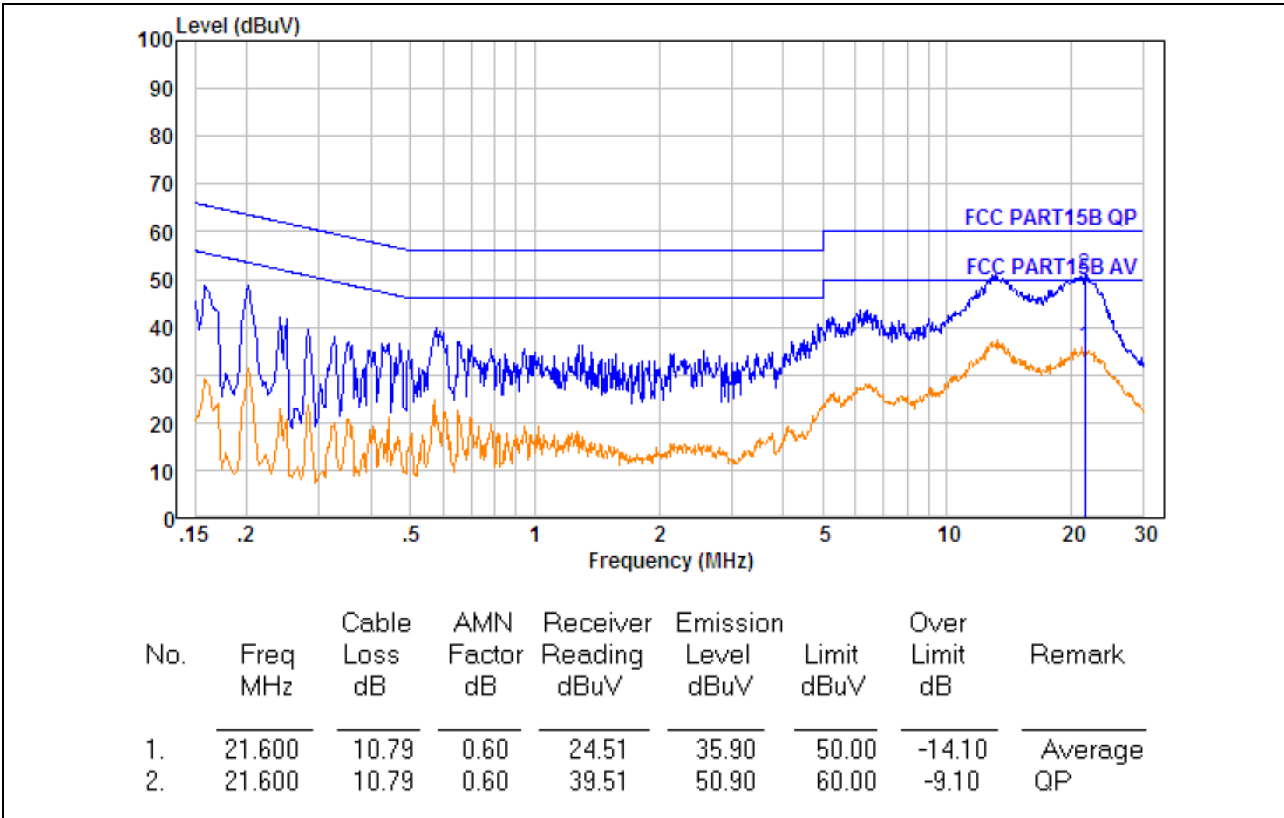

**DongGuan Precise Testing Service Co., Ltd.**

Building D, Baoding Technology Park, Guangming Road 2, Guangming Community, Dongcheng District, Dongguan, Guangdong, China

Tel: 86-769-23368601

Fax: 86-769-23368602

http:// www.pts-testing.com

### 3.2 RADIATED EMISSION MEASUREMENT

#### 3.2.1 RADIATED EMISSION LIMITS (Frequency Range 9kHz-1000MHz)

20dBc in any 100 kHz bandwidth outside the operating frequency band. In case the emission fall within the restricted band specified on 15.205(a), then the 15.209(a) limit in the table below has to be followed.

Frequencies (MHz)	Field Strength (microvolts/meter)	Measurement Distance (meters)
0.009~0.490	2400/F(KHz)	300
0.490~1.705	24000/F(KHz)	30
1.705~30.0	30	30
30~88	100	3
88~216	150	3
216~960	200	3
Above 960	500	3

#### LIMITS OF RADIATED EMISSION MEASUREMENT (Above 1000MHz)

FREQUENCY (MHz)	Class A (dBuV/m) (at 3M)		Class B (dBuV/m) (at 3M)	
	PEAK	AVERAGE	PEAK	AVERAGE
Above 1000	80	60	74	54

Notes:

- (1) The limit for radiated test was performed according to FCC PART 15C.
- (2) The tighter limit applies at the band edges.
- (3) Emission level (dBuV/m)=20log Emission level (uV/m).

Spectrum Parameter	Setting
Attenuation	Auto
Start Frequency	1000 MHz
Stop Frequency	10th carrier harmonic
RB / VB (emission in restricted band)	1 MHz / 1 MHz for Peak, 1 MHz / 10Hz for Average

Receiver Parameter	Setting
Attenuation	Auto
Start ~ Stop Frequency	9kHz~150kHz / RB 200Hz for QP/AVG
Start ~ Stop Frequency	150kHz~30MHz / RB 9kHz for QP/AVG
Start ~ Stop Frequency	30MHz~1000MHz / RB 120kHz for QP

#### DongGuan Precise Testing Service Co., Ltd.

Building D, Baoding Technology Park, Guangming Road 2, Guangming Community, Dongcheng District, Dongguan, Guangdong, China

### 3.2.2 TEST PROCEDURE

- a. The measuring distance of at 3 m shall be used for measurements at frequency up to 1GHz. For frequencies above 1GHz, any suitable measuring distance may be used.
- b. The EUT was placed on the top of a rotating table 0.8 meters above the ground at a 3 meter open area test site. The table was rotated 360 degrees to determine the position of the highest radiation.
- c. The height of the equipment or of the substitution antenna shall be 0.8 m; the height of the test antenna shall vary between 1 m to 4 m. Both horizontal and vertical polarizations of the antenna are set to make the measurement.
- d. The initial step in collecting conducted emission data is a spectrum analyzer peak detector mode pre-scanning the measurement frequency range. Significant peaks are then marked and then Quasi Peak detector mode re-measured.
- e. If the Peak Mode measured value compliance with and lower than Quasi Peak Mode Limit, the EUT shall be deemed to meet QP Limits and then no additional QP Mode measurement performed.
- f. For the actual test configuration, please refer to the related Item –EUT Test Photos.

Note:

Both horizontal and vertical antenna polarities were tested and performed pretest to three orthogonal axis. The worst case emissions were reported

### 3.2.3 DEVIATION FROM TEST STANDARD

No deviation

### 3.2.4 TEST SETUP

(A) Radiated Emission Test-Up Frequency Below 30MHz

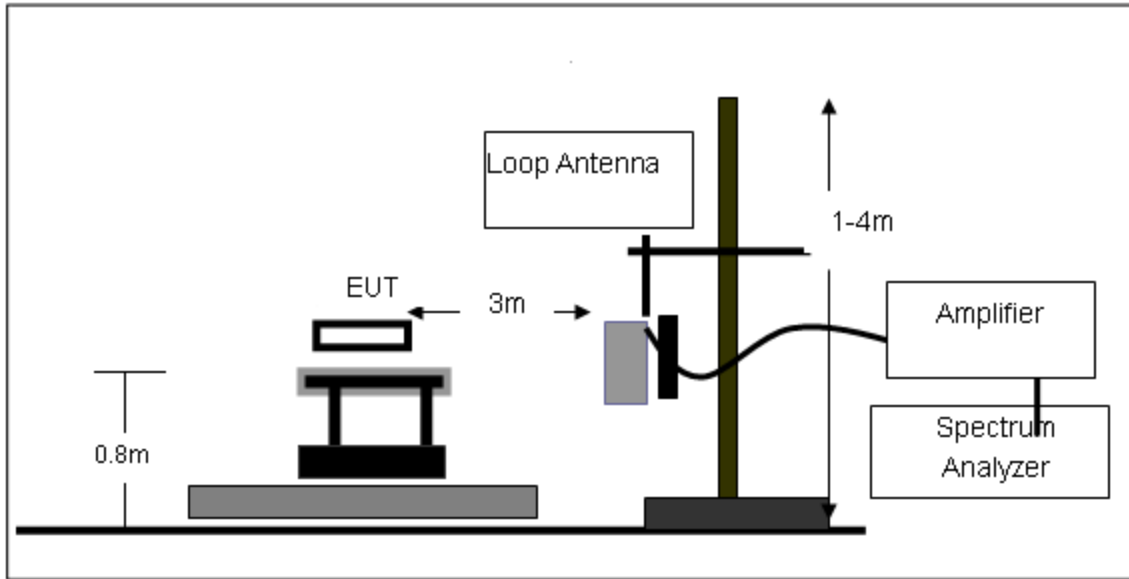

(B) Radiated Emission Test-Up Frequency 30MHz~1GHz

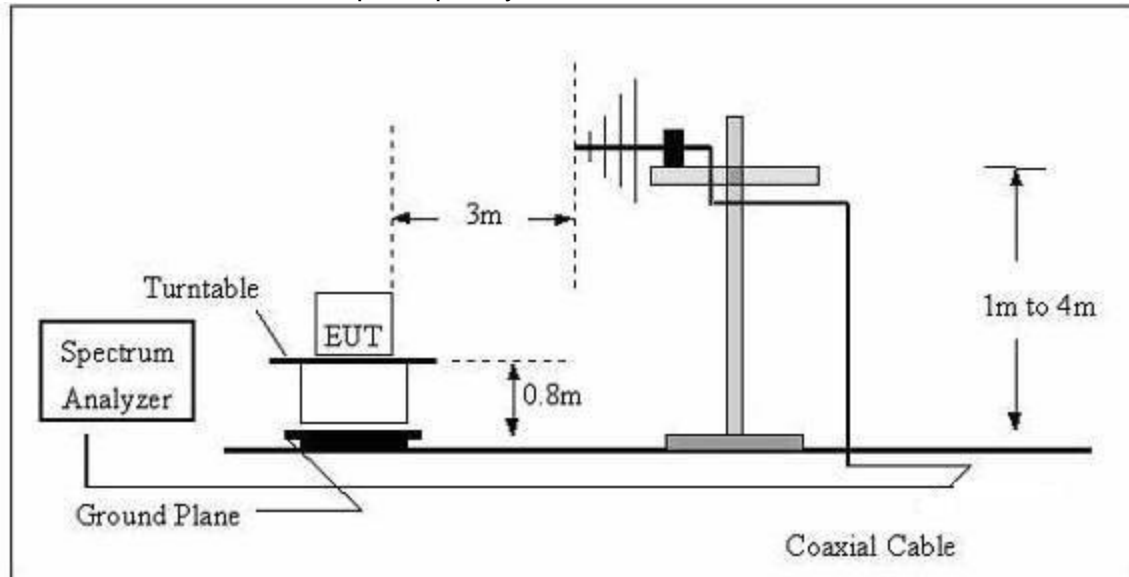

(C) Radiated Emission Test-Up Frequency Above 1GHz

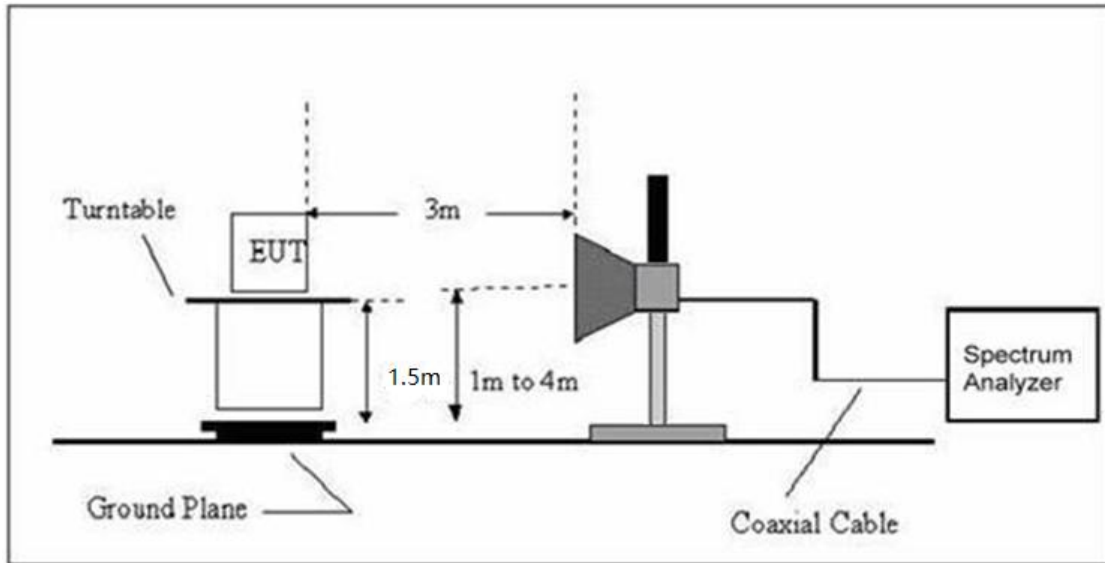

### 3.2.5 EUT OPERATING CONDITIONS

The EUT tested system was configured as the statements of 2.4 Unless otherwise a special operating condition is specified in the follows during the testing.

### 3.2.6 TEST RESULTS (BETWEEN 9KHZ – 30 MHZ)

EUT:	Glasses Free 3D Gaming Tablets	Model Name. :	X300
Temperature:	20 °C	Relative Humidity:	48%
Pressure:	1010 hPa	Test Voltage :	DC 3.80V
Test Mode :	TX	Polarization :	--

Freq.	Reading	Limit	Margin	State
(MHz)	(dBuV/m)	(dBuV/m)	(dB)	P/F
--	--	--	--	PASS
--	--	--	--	PASS

#### NOTE:

The amplitude of spurious emissions which are attenuated by more than 20dB below the permissible value has no need to be reported.

Distance extrapolation factor =  $40 \log(\text{specific distance}/\text{test distance})(\text{dB})$ ;

Limit line = specific limits(dBuv) + distance extrapolation factor.

### 3.2.7 TEST RESULTS (BETWEEN 30MHZ – 1GHZ)

EUT :	Glasses Free 3D Gaming Tablets	Model Name. :	X300
Temperature :	20 °C	Relative Humidity :	48%
Pressure:	1010 hPa	Test Voltage :	DC 3.80V
Test Mode :	Mode 1		

Test plot for Horizontal:

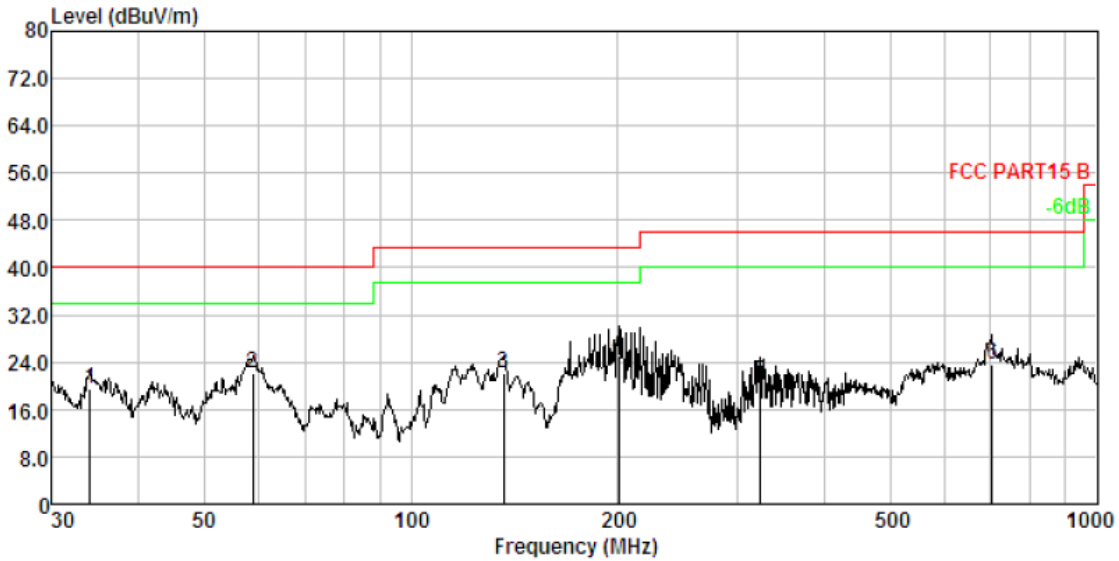

No.	Freq MHz	Cable Loss dB	ANT Factor dB/m	Receiver Reading dBuV	Preamplifier Factor dB	Emission Level dBuV/m	Limit dBuV/m	Over Limit dB	Remark
1.	34.037	1.17	13.33	34.88	30.01	19.37	40.00	-20.63	QP
2.	58.819	1.66	12.11	38.63	30.20	22.20	40.00	-17.80	QP
3.	136.460	2.43	13.11	36.95	30.50	21.99	43.50	-21.51	QP
4.	200.688	2.78	10.39	42.54	30.63	25.08	43.50	-18.42	QP
5.	323.320	3.21	13.72	34.67	30.80	20.80	46.00	-25.20	QP
6.	704.226	3.91	20.22	30.50	31.07	23.56	46.00	-22.44	QP

**Remark:**

Absolute Level= ReadingLevel+ Factor, Margin= Limit- Absolute Level



Test plot for Vertical:

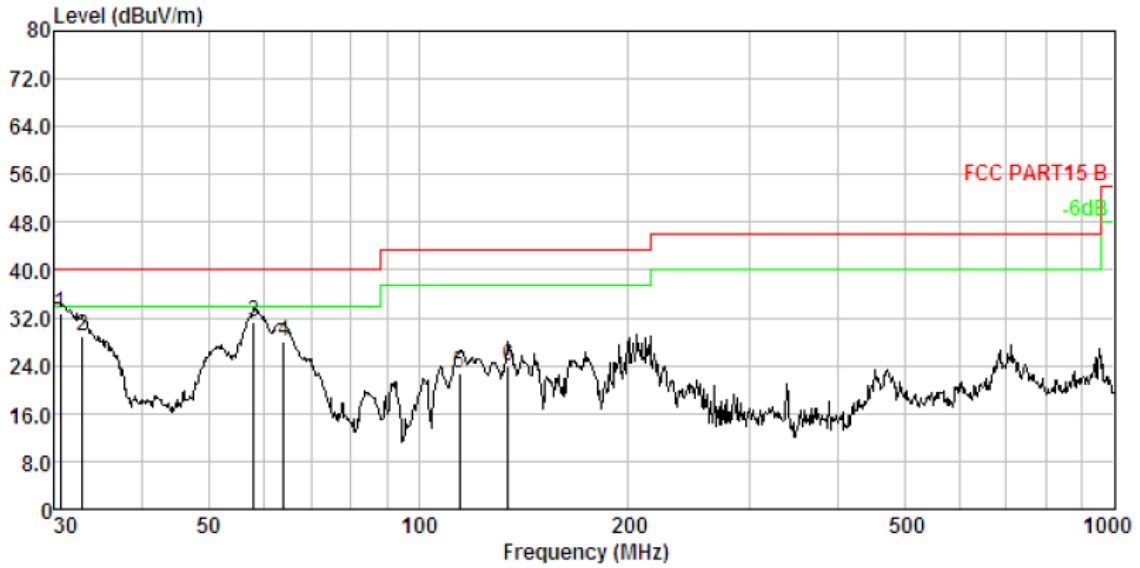

No.	Freq MHz	Cable Loss dB	ANT Factor dB/m	Receiver Reading dBuV	Preamp Factor dB	Emission Level dBuV/m	Limit dBuV/m	Over Limit dB	Remark
1.	30.531	1.07	13.24	48.31	29.98	32.64	40.00	-7.36	QP
2.	32.864	1.14	13.25	44.69	30.00	29.08	40.00	-10.92	QP
3.	57.999	1.65	12.06	47.81	30.20	31.32	40.00	-8.68	QP
4.	63.983	1.74	11.91	44.66	30.23	28.08	40.00	-11.92	QP
5.	114.515	2.27	11.51	39.33	30.44	22.67	43.50	-20.83	QP
6.	134.559	2.41	12.97	39.07	30.49	23.96	43.50	-19.54	QP

**Remark:**

Absolute Level= ReadingLevel+ Factor, Margin= Limit- Absolute Level

### 3.2.8 TEST RESULTS (ABOVE 1000 MHZ)

#### 802.11b

Normal Voltage

Polar (H/V)	Frequency	Meter Reading	Factor	Emission Level	Limits	Margin	Detector Type
	(MHz)	(dBuV)	(dB)	(dBuV/m)	(dBuV/m)	(dB)	
<b>operation frequency:2412</b>							
V	4824.00	58.94	-3.60	55.34	74.00	-18.66	Pk
V	4824.00	44.77	-3.60	41.17	54.00	-12.83	AV
H	4825.00	62.40	-3.60	58.80	74.00	-15.20	Pk
H	4825.00	48.05	-3.60	44.45	54.00	-9.55	AV
<b>Remark:</b>							
Absolute Level= ReadingLevel+ Factor, Margin= Limit- Absolute Level							

#### 802.11b

Normal Voltage

Polar (H/V)	Frequency	Meter Reading	Factor	Emission Level	Limits	Margin	Detector Type
	(MHz)	(dBuV)	(dB)	(dBuV/m)	(dBuV/m)	(dB)	
<b>operation frequency:2437</b>							
V	4874.00	58.68	-3.64	55.04	74.00	-18.96	Pk
V	4874.00	44.89	-3.64	41.25	54.00	-12.75	AV
H	4874.00	62.43	-3.64	58.79	74.00	-15.21	Pk
H	4874.00	47.89	-3.64	44.25	54.00	-9.75	AV
<b>Remark:</b>							
Absolute Level= ReadingLevel+ Factor, Margin= Limit- Absolute Level							

#### 802.11b

Normal Voltage

Polar (H/V)	Frequency	Meter Reading	Factor	Emission Level	Limits	Margin	Detector Type
	(MHz)	(dBuV)	(dB)	(dBuV/m)	(dBuV/m)	(dB)	
<b>operation frequency:2462</b>							
V	4924.00	59.50	-3.66	55.84	74.00	-18.16	Pk
V	4924.00	45.88	-3.66	42.22	54.00	-11.78	AV
H	4924.00	61.92	-3.66	58.26	74.00	-15.74	Pk
H	4924.00	49.62	-3.66	45.96	54.00	-8.04	AV
<b>Remark:</b>							
Absolute Level= ReadingLevel+ Factor, Margin= Limit- Absolute Level							

**802.11g**

Normal Voltage

Polar (H/V)	Frequency	Meter Reading	Factor	Emission Level	Limits	Margin	Detector Type
	(MHz)	(dBuV)	(dB)	(dBuV/m)	(dBuV/m)	(dB)	
<b>operation frequency:2412</b>							
V	4824.00	58.46	-3.60	54.86	74.00	-19.14	Pk
V	4824.00	44.04	-3.60	40.44	54.00	-13.56	AV
H	4824.00	60.18	-3.60	56.58	74.00	-17.42	Pk
H	4824.00	45.81	-3.60	42.21	54.00	-11.79	AV
<b>Remark:</b>							
Absolute Level= ReadingLevel+ Factor, Margin= Limit- Absolute Level							

**802.11g**

Normal Voltage

Polar (H/V)	Frequency	Meter Reading	Factor	Emission Level	Limits	Margin	Detector Type
	(MHz)	(dBuV)	(dB)	(dBuV/m)	(dBuV/m)	(dB)	
<b>operation frequency:2437</b>							
V	4874.00	58.10	-3.64	54.46	74.00	-19.54	Pk
V	4874.00	43.91	-3.64	40.27	54.00	-13.73	AV
H	4874.00	60.47	-3.64	56.83	74.00	-17.17	Pk
H	4874.00	45.75	-3.64	42.11	54.00	-11.89	AV
<b>Remark:</b>							
Absolute Level= ReadingLevel+ Factor, Margin= Limit- Absolute Level							

**802.11g**

Normal Voltage

Polar (H/V)	Frequency	Meter Reading	Factor	Emission Level	Limits	Margin	Detector Type
	(MHz)	(dBuV)	(dB)	(dBuV/m)	(dBuV/m)	(dB)	
<b>operation frequency:2462</b>							
V	4924.00	58.29	-3.66	54.63	74.00	-19.37	Pk
V	4924.00	44.43	-3.66	40.77	54.00	-13.23	AV
H	4924.00	59.93	-3.66	56.27	74.00	-17.73	Pk
H	4924.00	45.93	-3.66	42.27	54.00	-11.73	AV
<b>Remark:</b>							
Absolute Level= ReadingLevel+ Factor, Margin= Limit- Absolute Level							

**802.11n-HT20**

Normal Voltage

Polar (H/V)	Frequency	Meter Reading	Factor	Emission Level	Limits	Margin	Detector Type
	(MHz)	(dBuV)	(dB)	(dBuV/m)	(dBuV/m)	(dB)	
<b>operation frequency:2412</b>							
V	4824.00	57.84	-3.60	54.24	74.00	-19.76	Pk
V	4824.00	44.38	-3.60	40.78	54.00	-13.22	AV
H	4824.00	60.34	-3.60	56.74	74.00	-17.26	Pk
H	4824.00	44.96	-3.60	41.36	54.00	-12.64	AV
<b>Remark:</b>							
Absolute Level= ReadingLevel+ Factor, Margin= Limit- Absolute Level							

**802.11n-HT20**

Normal Voltage

Polar (H/V)	Frequency	Meter Reading	Factor	Emission Level	Limits	Margin	Detector Type
	(MHz)	(dBuV)	(dB)	(dBuV/m)	(dBuV/m)	(dB)	
<b>operation frequency:2437</b>							
V	4874.00	57.68	-3.64	54.04	74.00	-19.96	Pk
V	4874.00	44.10	-3.64	40.46	54.00	-13.54	AV
H	4874.00	59.77	-3.64	56.13	74.00	-17.87	Pk
H	4874.00	45.32	-3.64	41.68	54.00	-12.32	AV
<b>Remark:</b>							
Absolute Level= ReadingLevel+ Factor, Margin= Limit- Absolute Level							

**802.11n-HT20**

Normal Voltage

Polar (H/V)	Frequency	Meter Reading	Factor	Emission Level	Limits	Margin	Detector Type
	(MHz)	(dBuV)	(dB)	(dBuV/m)	(dBuV/m)	(dB)	
<b>operation frequency:2462</b>							
V	4924.00	58.19	-3.66	54.53	74.00	-19.47	Pk
V	4924.00	43.90	-3.66	40.24	54.00	-13.76	AV
H	4924.00	60.54	-3.66	56.88	74.00	-17.12	Pk
H	4924.00	44.89	-3.66	41.23	54.00	-12.77	AV
<b>Remark:</b>							
Absolute Level= ReadingLevel+ Factor, Margin= Limit- Absolute Level							

**802.11n-HT40**

Normal Voltage

Polar (H/V)	Frequency	Meter Reading	Factor	Emission Level	Limits	Margin	Detector Type
	(MHz)	(dBuV)	(dB)	(dBuV/m)	(dBuV/m)	(dB)	
<b>operation frequency:2422</b>							
V	4844.00	56.85	-3.61	53.24	74.00	-20.76	Pk
V	4844.00	43.56	-3.61	39.95	54.00	-14.05	AV
H	4844.00	59.06	-3.61	55.45	74.00	-18.55	Pk
H	4844.00	44.44	-3.61	40.83	54.00	-13.17	AV
<b>Remark:</b>							
Absolute Level= ReadingLevel+ Factor, Margin= Limit- Absolute Level							

**802.11n-HT40**

Normal Voltage

Polar (H/V)	Frequency	Meter Reading	Factor	Emission Level	Limits	Margin	Detector Type
	(MHz)	(dBuV)	(dB)	(dBuV/m)	(dBuV/m)	(dB)	
<b>operation frequency:2437</b>							
V	4874.00	56.74	-3.63	53.11	74.00	-20.89	Pk
V	4874.00	43.20	-3.63	39.57	54.00	-14.43	AV
H	4874.00	58.87	-3.63	55.24	74.00	-18.76	Pk
H	4874.00	44.59	-3.63	40.96	54.00	-13.04	AV
<b>Remark:</b>							
Absolute Level= ReadingLevel+ Factor, Margin= Limit- Absolute Level							

**802.11n-HT40**

Normal Voltage

Polar (H/V)	Frequency	Meter Reading	Factor	Emission Level	Limits	Margin	Detector Type
	(MHz)	(dBuV)	(dB)	(dBuV/m)	(dBuV/m)	(dB)	
<b>operation frequency:2452</b>							
V	4904.00	56.90	-3.65	53.25	74.00	-20.75	Pk
V	4904.00	43.33	-3.65	39.68	54.00	-14.32	AV
H	4904.00	58.76	-3.65	55.11	74.00	-18.89	Pk
H	4904.00	44.18	-3.65	40.53	54.00	-13.47	AV
<b>Remark:</b>							
Absolute Level= ReadingLevel+ Factor, Margin= Limit- Absolute Level							

**BT LE**

Normal Voltage

Polar (H/V)	Frequency	Meter Reading	Factor	Emission Level	Limits	Margin	Detector Type
	(MHz)	(dBuV)	(dB)	(dBuV/m)	(dBuV/m)	(dB)	
<b>operation frequency:2412</b>							
V	4804.00	55.28	-1.06	54.22	74.00	-19.78	Pk
V	4804.00	40.60	-1.06	39.54	54.00	-14.46	AV
H	4804.00	56.34	-1.06	55.28	74.00	-18.72	Pk
H	4804.00	41.73	-1.06	40.67	54.00	-13.33	AV
<b>Remark:</b>							
Absolute Level= ReadingLevel+ Factor, Margin= Limit- Absolute Level							

**BT LE**

Normal Voltage

Polar (H/V)	Frequency	Meter Reading	Factor	Emission Level	Limits	Margin	Detector Type
	(MHz)	(dBuV)	(dB)	(dBuV/m)	(dBuV/m)	(dB)	
<b>operation frequency:2437</b>							
V	4880.00	55.74	-0.93	54.81	74.00	-19.19	Pk
V	4880.00	40.21	-0.93	39.28	54.00	-14.72	AV
H	4880.00	56.39	-0.93	55.46	74.00	-18.54	Pk
H	4880.00	41.15	-0.93	40.22	54.00	-13.78	AV
<b>Remark:</b>							
Absolute Level= ReadingLevel+ Factor, Margin= Limit- Absolute Level							

**BT LE**

Normal Voltage

Polar (H/V)	Frequency	Meter Reading	Factor	Emission Level	Limits	Margin	Detector Type
	(MHz)	(dBuV)	(dB)	(dBuV/m)	(dBuV/m)	(dB)	
<b>operation frequency:2462</b>							
V	4960.00	55.44	-0.87	54.57	74.00	-19.43	Pk
V	4960.00	40.31	-0.87	39.44	54.00	-14.56	AV
H	4960.00	56.19	-0.87	55.32	74.00	-18.68	Pk
H	4960.00	41.51	-0.87	40.64	54.00	-13.36	AV
<b>Remark:</b>							
Absolute Level= ReadingLevel+ Factor, Margin= Limit- Absolute Level							

The measurements were more than 20 dB below the limit and not reported

Note: 1. Measuring frequencies from 9k~26.5GHz, No emission found between lowest internal used/generated frequency to 30MHz.

2. Radiated emissions measured in frequency range from 9k~26.5GHz were made with an instrument using Peak detector mode.

3. Only worst mode is reported and 802.11b high channel have the worst result.

**DongGuan Precise Testing Service Co., Ltd.**

Building D, Baoding Technology Park, Guangming Road 2, Guangming Community, Dongcheng District, Dongguan, Guangdong, China

Results of Restricted Band and Bandedge Test:

**802.11b**

Normal Voltage

Polar (H/V)	Frequency	Meter Reading	Factor	Emission Level	Limits	Margin	Detector Type
	(MHz)	(dBuV)	(dB)	(dBuV/m)	(dBuV/m)	(dB)	
<b>operation frequency:2412</b>							
V	2390.00	55.19	-3.62	51.57	74.00	-22.43	Pk
V	2390.00	39.25	-3.62	35.63	54.00	-18.37	AV
V	2400.00	55.81	-3.62	52.19	74.00	-21.81	Pk
V	2400.00	39.97	-3.62	36.35	54.00	-17.65	AV
V	4824.00	59.48	-3.60	55.88	74.00	-18.12	Pk
V	4824.00	44.73	-3.60	41.13	54.00	-12.87	AV
H	2390.00	55.51	-3.62	51.89	74.00	-22.11	Pk
H	2390.00	39.25	-3.62	35.63	54.00	-18.37	AV
H	2400.00	55.90	-3.62	52.28	74.00	-21.72	Pk
H	2400.00	40.19	-3.62	36.57	54.00	-17.43	AV
H	4824.00	60.72	-3.60	57.12	74.00	-16.88	Pk
H	4824.00	49.03	-3.60	45.43	54.00	-8.57	AV
<b>Remark:</b>							
Absolute Level= ReadingLevel+ Factor, Margin= Limit- Absolute Level							

**802.11b**

Normal Voltage

Polar (H/V)	Frequency	Meter Reading	Factor	Emission Level	Limits	Margin	Detector Type
	(MHz)	(dBuV)	(dB)	(dBuV/m)	(dBuV/m)	(dB)	
<b>operation frequency:2462</b>							
V	2483.50	55.05	-3.59	51.46	74.00	-22.54	Pk
V	2483.50	39.11	-3.59	35.52	54.00	-18.48	AV
V	4924.00	58.81	-3.66	55.15	74.00	-18.85	Pk
V	4924.00	46.55	-3.66	42.89	54.00	-11.11	AV
H	2483.50	55.25	-3.59	51.66	74.00	-22.34	Pk
H	2483.50	38.91	-3.59	35.32	54.00	-18.68	AV
H	4924.00	61.12	-3.66	57.46	74.00	-16.54	Pk
H	4924.00	49.51	-3.66	45.85	54.00	-8.15	AV
<b>Remark:</b>							
Absolute Level= ReadingLevel+ Factor, Margin= Limit- Absolute Level							

**802.11g**

Normal Voltage

Polar (H/V)	Frequency	Meter Reading	Factor	Emission Level	Limits	Margin	Detector Type
	(MHz)	(dBuV)	(dB)	(dBuV/m)	(dBuV/m)	(dB)	
<b>operation frequency:2412</b>							
V	2390.00	55.18	-3.62	51.56	74.00	-22.44	Pk
V	2390.00	39.04	-3.62	35.42	54.00	-18.58	AV
V	2400.00	56.37	-3.62	52.75	74.00	-21.25	Pk
V	2400.00	40.06	-3.62	36.44	54.00	-17.56	AV
V	4824.00	58.54	-3.60	54.94	74.00	-19.06	Pk
V	4824.00	43.86	-3.60	40.26	54.00	-13.74	AV
H	2390.00	55.28	-3.62	51.66	74.00	-22.34	Pk
H	2390.00	39.45	-3.62	35.83	54.00	-18.17	AV
H	2400.00	55.74	-3.62	52.12	74.00	-21.88	Pk
H	2400.00	39.86	-3.62	36.24	54.00	-17.76	AV
H	4824.00	60.53	-3.60	56.93	74.00	-17.07	Pk
H	4824.00	45.86	-3.60	42.26	54.00	-11.74	AV
<b>Remark:</b>							
Absolute Level= ReadingLevel+ Factor, Margin= Limit- Absolute Level							

**802.11g**

Normal Voltage

Polar (H/V)	Frequency	Meter Reading	Factor	Emission Level	Limits	Margin	Detector Type
	(MHz)	(dBuV)	(dB)	(dBuV/m)	(dBuV/m)	(dB)	
<b>operation frequency:2462</b>							
V	2483.50	54.81	-3.59	51.22	74.00	-22.78	Pk
V	2483.50	39.15	-3.59	35.56	54.00	-18.44	AV
V	4924.00	57.74	-3.66	54.08	74.00	-19.92	Pk
V	4924.00	43.83	-3.66	40.17	54.00	-13.83	AV
H	2483.50	55.27	-3.59	51.68	74.00	-22.32	Pk
H	2483.50	39.93	-3.59	36.34	54.00	-17.66	AV
H	4924.00	60.10	-3.66	56.44	74.00	-17.56	Pk
H	4924.00	46.29	-3.66	42.63	54.00	-11.37	AV
<b>Remark:</b>							
Absolute Level= ReadingLevel+ Factor, Margin= Limit- Absolute Level							



**802.11n-HT20**

Normal Voltage

Polar (H/V)	Frequency	Meter Reading	Factor	Emission Level	Limits	Margin	Detector Type
	(MHz)	(dBuV)	(dB)	(dBuV/m)	(dBuV/m)	(dB)	
<b>operation frequency:2412</b>							
V	2390.00	54.86	-3.62	51.24	74.00	-22.76	Pk
V	2390.00	39.37	-3.62	35.75	54.00	-18.25	AV
V	2400.00	55.8	-3.62	52.18	74.00	-21.82	Pk
V	2400.00	40.30	-3.62	36.68	54.00	-17.32	AV
V	4824.00	58.04	-3.60	54.44	74.00	-19.56	Pk
V	4824.00	43.83	-3.60	40.23	54.00	-13.77	AV
H	2390.00	55.51	-3.62	51.89	74.00	-22.11	Pk
H	2390.00	38.94	-3.62	35.32	54.00	-18.68	AV
H	2400.00	56.16	-3.62	52.54	74.00	-21.46	Pk
H	2400.00	40.29	-3.62	36.67	54.00	-17.33	AV
H	4824.00	59.71	-3.60	56.11	74.00	-17.89	Pk
H	4824.00	44.96	-3.60	41.36	54.00	-12.64	AV
<b>Remark:</b>							
Absolute Level= ReadingLevel+ Factor, Margin= Limit- Absolute Level							

**802.11n-HT20**

Normal Voltage

Polar (H/V)	Frequency	Meter Reading	Factor	Emission Level	Limits	Margin	Detector Type
	(MHz)	(dBuV)	(dB)	(dBuV/m)	(dBuV/m)	(dB)	
<b>operation frequency:2462</b>							
V	2483.50	55.48	-3.59	51.89	74.00	-22.11	Pk
V	2483.50	39.13	-3.59	35.54	54.00	-18.46	AV
V	4924.00	57.94	-3.66	54.28	74.00	-19.72	Pk
V	4924.00	44.21	-3.66	40.55	54.00	-13.45	AV
H	2483.50	54.92	-3.59	51.33	74.00	-22.67	Pk
H	2483.50	40.27	-3.59	36.68	54.00	-17.32	AV
H	4924.00	59.81	-3.66	56.15	74.00	-17.85	Pk
H	4924.00	45.19	-3.66	41.53	54.00	-12.47	AV
<b>Remark:</b>							
Absolute Level= ReadingLevel+ Factor, Margin= Limit- Absolute Level							

**802.11n-HT40**

Normal Voltage

Polar (H/V)	Frequency	Meter Reading	Factor	Emission Level	Limits	Margin	Detector Type
	(MHz)	(dBuV)	(dB)	(dBuV/m)	(dBuV/m)	(dB)	
<b>operation frequency:2422</b>							
V	2390.00	55.45	-3.62	51.83	74.00	-22.17	Pk
V	2390.00	39.16	-3.62	35.54	54.00	-18.46	AV
V	2400.00	55.84	-3.62	52.22	74.00	-21.78	Pk
V	2400.00	40.42	-3.62	36.80	54.00	-17.2	AV
V	4844.00	56.97	-3.61	53.36	74.00	-20.64	Pk
V	4844.00	43.25	-3.61	39.64	54.00	-14.36	AV
H	2390.00	54.94	-3.62	51.32	74.00	-22.68	Pk
H	2390.00	39.08	-3.62	35.46	54.00	-18.54	AV
H	2400.00	56.59	-3.62	52.97	74.00	-21.03	Pk
H	2400.00	39.86	-3.62	36.24	54.00	-17.76	AV
H	4844.00	59.25	-3.61	55.64	74.00	-18.36	Pk
H	4844.00	43.74	-3.61	40.13	54.00	-13.87	AV
<b>Remark:</b>							
Absolute Level= ReadingLevel+ Factor, Margin= Limit- Absolute Level							

**802.11n-HT40**

Normal Voltage

Polar (H/V)	Frequency	Meter Reading	Factor	Emission Level	Limits	Margin	Detector Type
	(MHz)	(dBuV)	(dB)	(dBuV/m)	(dBuV/m)	(dB)	
<b>operation frequency:2452</b>							
V	2483.50	55.53	-3.59	51.94	74.00	-22.06	Pk
V	2483.50	39.20	-3.59	35.61	54.00	-18.39	AV
V	4904.00	57.21	-3.65	53.56	74.00	-20.44	Pk
V	4904.00	42.88	-3.65	39.23	54.00	-14.77	AV
H	2483.50	55.49	-3.59	51.90	74.00	-22.1	Pk
H	2483.50	38.81	-3.59	35.22	54.00	-18.78	AV
H	4904.00	59.33	-3.65	55.68	74.00	-18.32	Pk
H	4904.00	44.18	-3.65	40.53	54.00	-13.47	AV
<b>Remark:</b>							
Absolute Level= ReadingLevel+ Factor, Margin= Limit- Absolute Level							

**GFSK**

Normal Voltage

Polar (H/V)	Frequency	Meter Reading	Factor	Emission Level	Limits	Margin	Detector Type
	(MHz)	(dBuV)	(dB)	(dBuV/m)	(dBuV/m)	(dB)	
<b>operation frequency:2402</b>							
V	2390.00	55.19	-3.62	51.57	74.00	-22.43	Pk
V	2390.00	38.85	-3.62	35.23	54.00	-18.77	AV
V	2400.00	56.16	-3.62	52.54	74.00	-21.46	Pk
V	2400.00	40.30	-3.62	36.68	54.00	-17.32	AV
V	4804.00	54.39	-1.06	53.33	74.00	-20.67	Pk
V	4804.00	38.71	-1.06	37.65	54.00	-16.35	AV
H	2390.00	54.90	-3.62	51.28	74.00	-22.72	Pk
H	2390.00	38.86	-3.62	35.24	54.00	-18.76	AV
H	2400.00	55.87	-3.62	52.25	74.00	-21.75	Pk
H	2400.00	40.40	-3.62	36.78	54.00	-17.22	AV
H	4804.00	54.52	-1.06	53.46	74.00	-20.54	Pk
H	4804.00	39.38	-1.06	38.32	54.00	-15.68	AV
<b>Remark:</b>							
Absolute Level= ReadingLevel+ Factor, Margin= Limit- Absolute Level							

**GFSK**

Normal Voltage

Polar (H/V)	Frequency	Meter Reading	Factor	Emission Level	Limits	Margin	Detector Type
	(MHz)	(dBuV)	(dB)	(dBuV/m)	(dBuV/m)	(dB)	
<b>operation frequency:2480</b>							
V	2483.50	54.87	-3.59	51.28	74.00	-22.72	Pk
V	2483.50	39.12	-3.59	35.53	54.00	-18.47	AV
V	4960.00	54.05	-0.87	53.18	74.00	-20.82	Pk
V	4960.00	38.32	-0.87	37.45	54.00	-16.55	AV
H	2483.50	55.32	-3.59	51.73	74.00	-22.27	Pk
H	2483.50	38.97	-3.59	35.38	54.00	-18.62	AV
H	4960.00	54.71	-0.87	53.84	74.00	-20.16	Pk
H	4960.00	38.23	-0.87	37.36	54.00	-16.64	AV
<b>Remark:</b>							
Absolute Level= ReadingLevel+ Factor, Margin= Limit- Absolute Level							

The measurements were more than 20 dB below the limit and not reported

*Note: 1. Measuring frequencies from 9k~26.5GHz, No emission found between lowest internal used/generated frequency to 30MHz.*

*2. Radiated emissions measured in frequency range from 9k~26.5GHz were made with an instrument using Peak detector mode.*

**DongGuan Precise Testing Service Co., Ltd.**

Building D, Baoding Technology Park, Guangming Road 2, Guangming Community, Dongcheng District, Dongguan, Guangdong, China

## 4. POWER SPECTRAL DENSITY TEST

### 4.1 APPLIED PROCEDURES / LIMIT

FCC Part15 (15.247) , Subpart C				
Section	Test Item	Limit	Frequency Range (MHz)	Result
15.247	Power Spectral Density	8 dBm (in any 3KHz)	2400-2483.5	PASS

#### 4.1.1 TEST PROCEDURE

1. Set analyzer center frequency to DTS channel center frequency.
2. Set the span to 1.5 times the DTS channel bandwidth.
3. Set the RBW ,  $3 \text{ kHz} \leq \text{RBW} \leq 100 \text{ kHz}$ .
4. Set the VBW  $\geq 3 \times \text{RBW}$ .
5. Detector = peak.
6. Sweep time = auto couple.
7. Trace mode = max hold.
8. Allow trace to fully stabilize.
9. Use the peak marker function to determine the maximum amplitude level.
10. If measured value exceeds limit, reduce RBW (no less than 3 kHz) and repeat.

#### 4.1.2 DEVIATION FROM STANDARD

No deviation.

#### 4.1.3 TEST SETUP

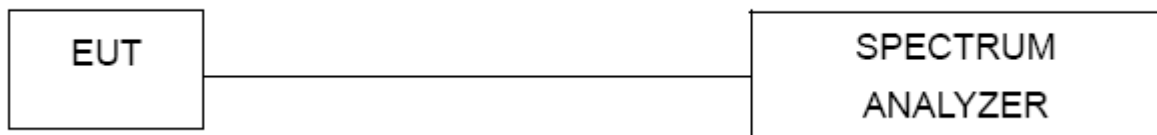

#### 4.1.4 EUT OPERATION CONDITIONS

The EUT tested system was configured as the statements of 2.1 Unless otherwise a special operating condition is specified in the follows during the testing.

#### 4.1.5 TEST RESULTS

EUT :	Glasses Free 3D Gaming Tablets	Model Name :	X300
Temperature :	25 °C	Relative Humidity :	60%
Pressure :	1015 hPa	Test Voltage :	DC 3.80V

Test Mode	Frequency	Power Density (dBm/3kHz)	Limit (dBm/3kHz)	Result
802.11b	2412 MHz	-18.477	8	PASS
	2437 MHz	-18.444	8	PASS
	2462 MHz	-18.605	8	PASS
802.11g	2412 MHz	-21.472	8	PASS
	2437 MHz	-21.570	8	PASS
	2462 MHz	-21.682	8	PASS
802.11n-HT20	2412 MHz	-22.130	8	PASS
	2437 MHz	-20.975	8	PASS
	2462 MHz	-22.080	8	PASS
802.11b-HT40	2422 MHz	-21.819	8	PASS
	2437 MHz	-21.835	8	PASS
	2452 MHz	-22.228	8	PASS
BT LE	2402 MHz	-17.180	8	PASS
	2440 MHz	-17.239	8	PASS
	2480 MHz	-17.665	8	PASS

#### DongGuan Precise Testing Service Co., Ltd.

Building D, Baoding Technology Park, Guangming Road 2, Guangming Community, Dongcheng District, Dongguan, Guangdong, China

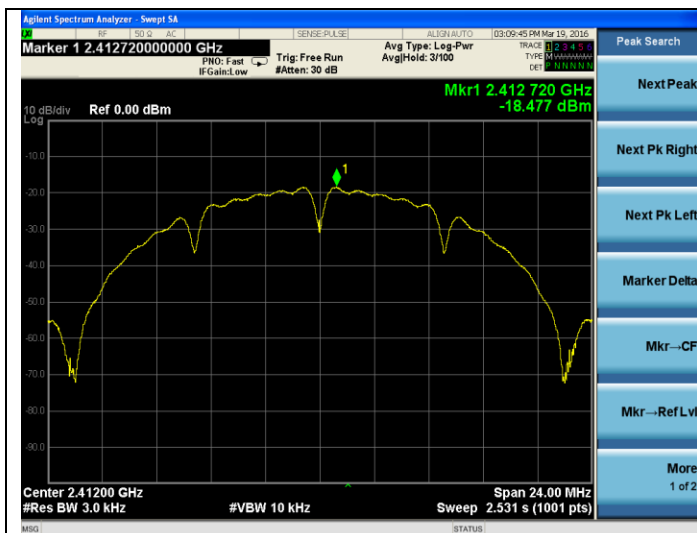

802.11b-2412MHz

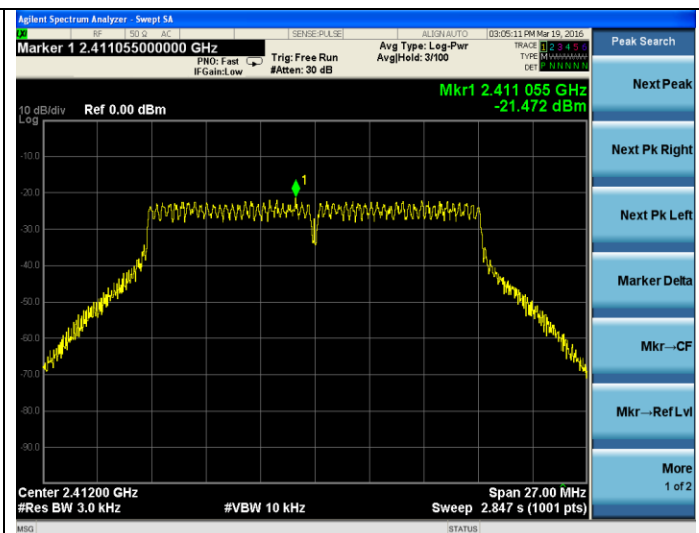

802.11g-2412MHz

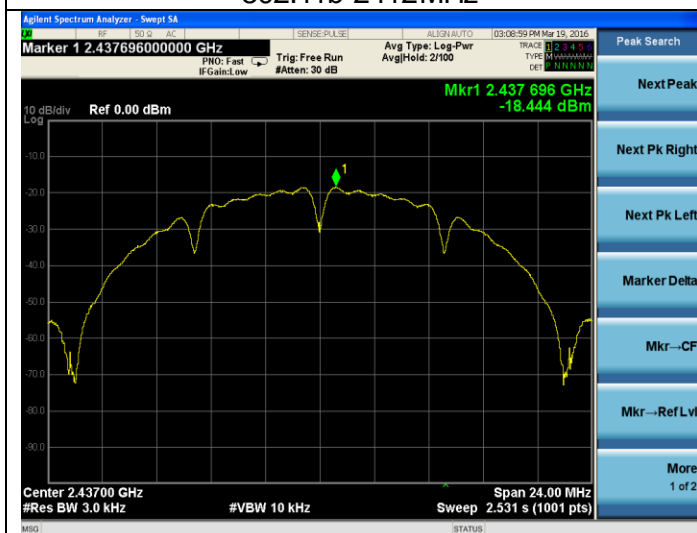

802.11b-2437MHz

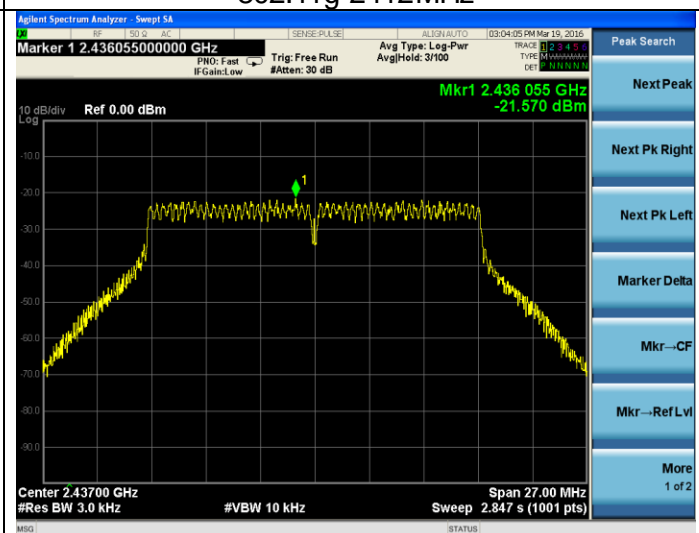

802.11g-2437MHz

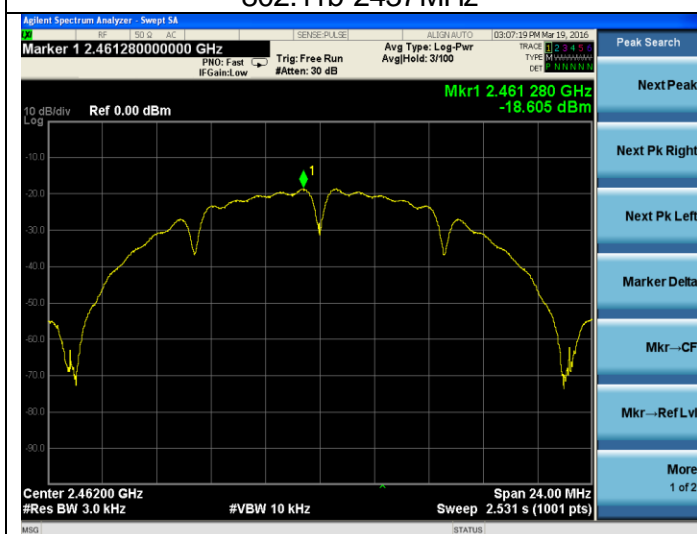

802.11b-2462MHz

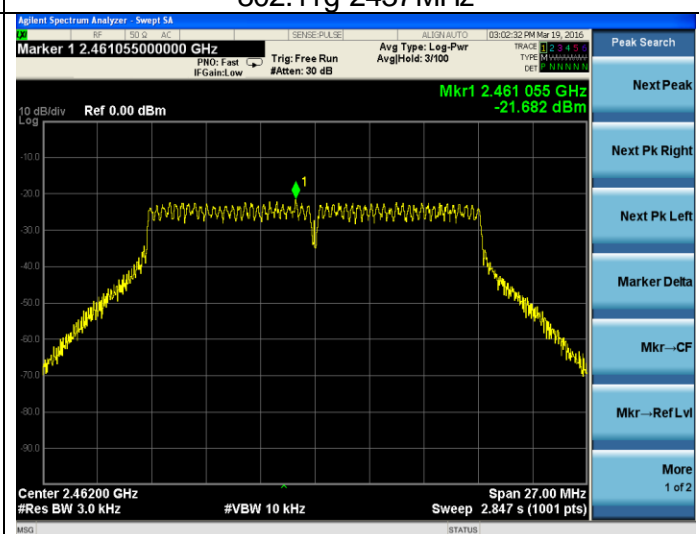

802.11g-2462MHz

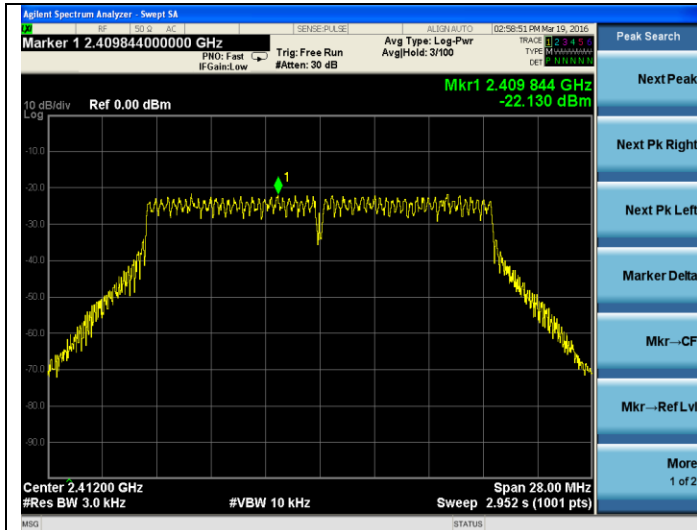

802.11n(HT20)-2412MHz

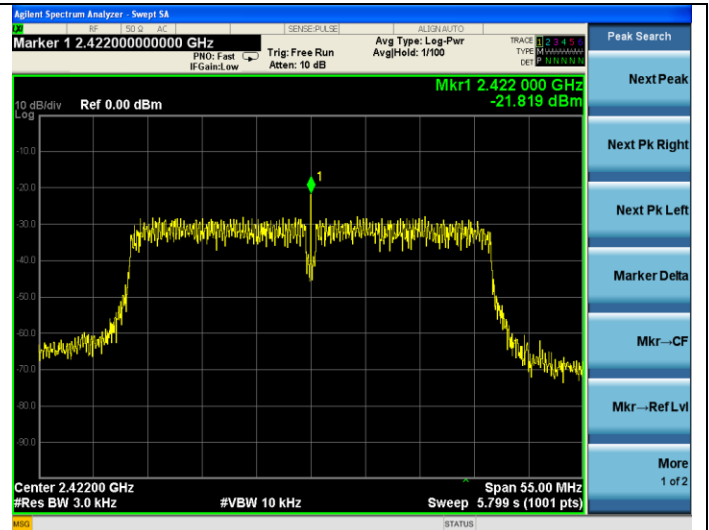

802.11n(HT40)-2422MHz

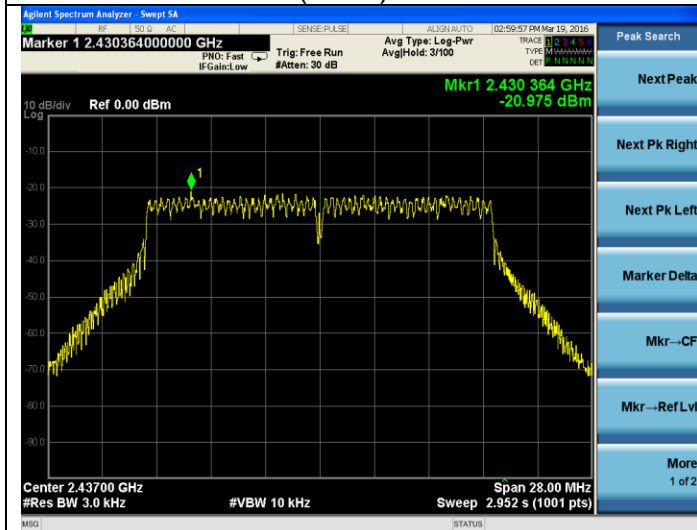

802.11n(HT20)-2437MHz

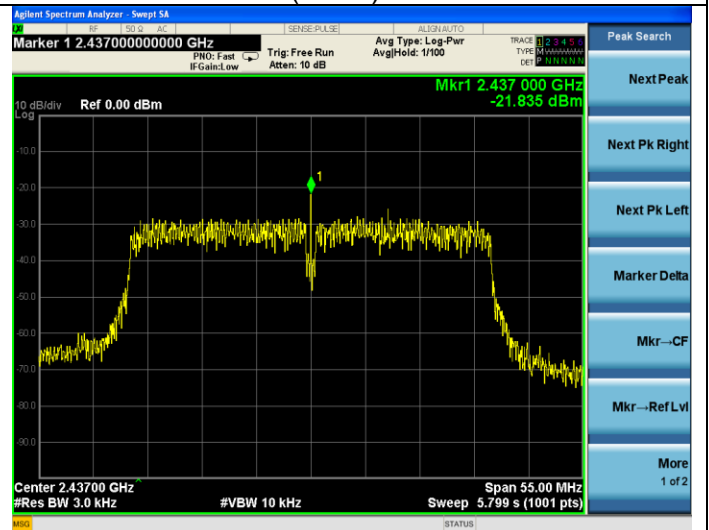

802.11n(HT40)-2437MHz

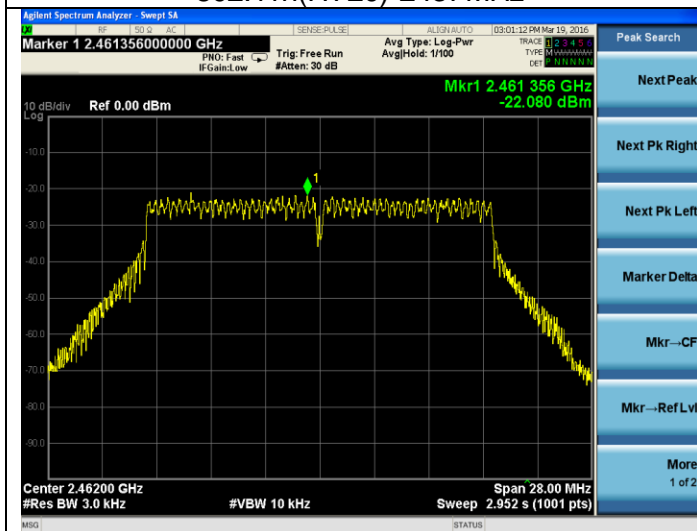

802.11n(HT20)-2462MHz

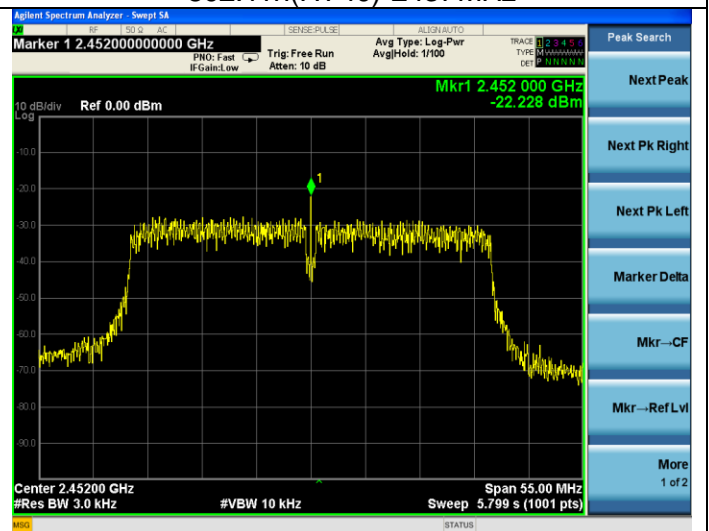

802.11n(HT40)-2452MHz

**DongGuan Precise Testing Service Co., Ltd.**

Building D, Baoding Technology Park, Guangming Road 2, Guangming Community, Dongcheng District, Dongguan, Guangdong, China

Tel: 86-769-23368601

Fax: 86-769-23368602

http:// www.pts-testing.com

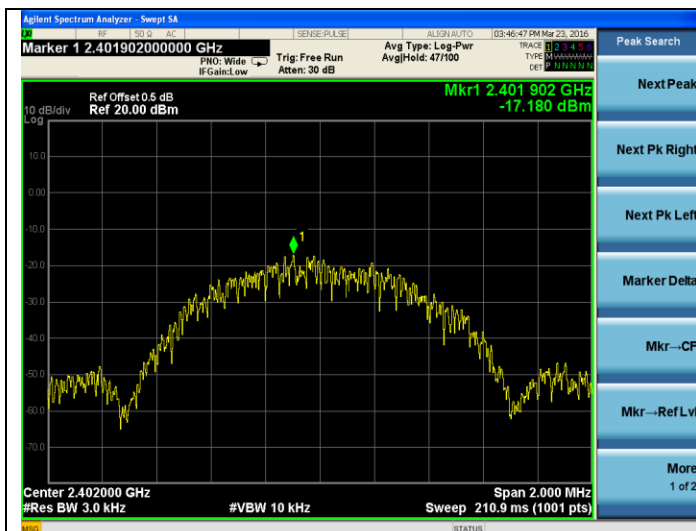

BT LE-2402MHz

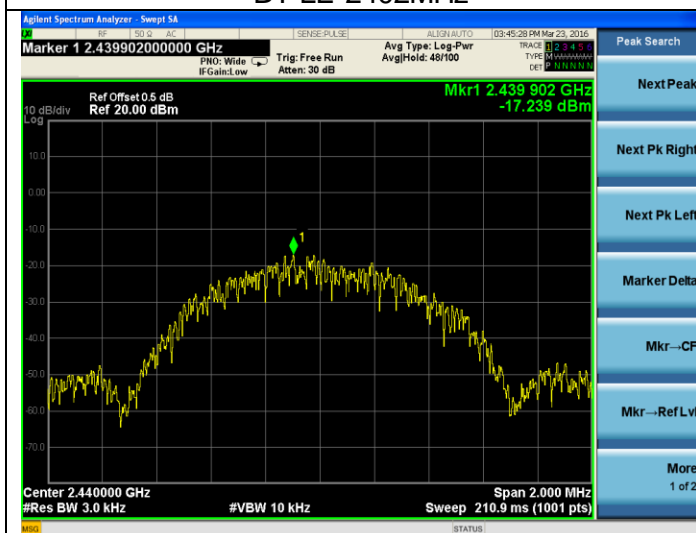

BT LE-HT20-2440MHz

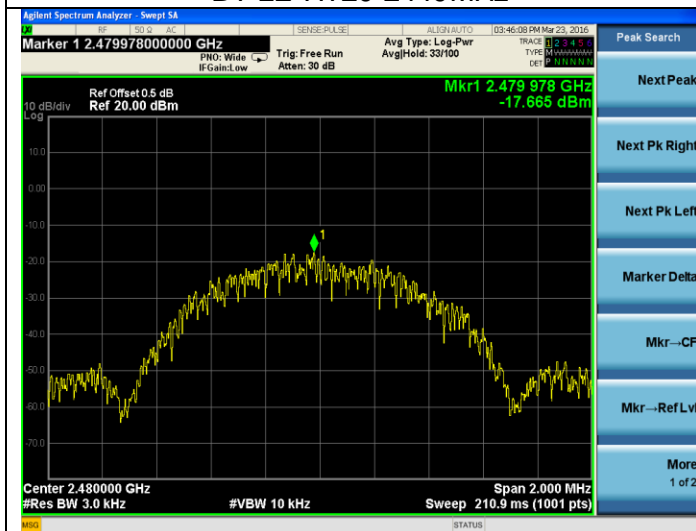

BT LE-2480MHz



## 5. BANDWIDTH TEST

### 5.1 APPLIED PROCEDURES / LIMIT

FCC Part15 (15.247) , Subpart C				
Section	Test Item	Limit	Frequency Range (MHz)	Result
15.247(a)(2)	Bandwidth	$\geq 500\text{KHz}$ (6dB bandwidth)	2400-2483.5	PASS

#### 5.1.1 TEST PROCEDURE

1. Set resolution bandwidth (RBW) = 100 kHz.
2. Set the video bandwidth (VBW)  $\geq 3 \times$  RBW.
3. Detector = Peak.
4. Trace mode = max hold.
5. Sweep = auto couple.
6. Allow the trace to stabilize.
7. Measure the maximum width of the emission that is constrained by the frequencies associated with the two outermost amplitude points (upper and lower) that are attenuated by 6 dB relative to the maximum level measured in the fundamental emission.

#### 5.1.2 DEVIATION FROM STANDARD

No deviation.

#### 5.1.3 TEST SETUP



#### 5.1.4 EUT OPERATION CONDITIONS

The EUT tested system was configured as the statements of 2.4 Unless otherwise a special operating condition is specified in the follows during the testing.

### 5.1.5 TEST RESULTS

EUT :	Glasses Free 3D Gaming Tablets	Model Name :	X300
Temperature :	25 °C	Relative Humidity :	60%
Pressure :	1012 hPa	Test Voltage :	DC 3.80V

Test Mode	Frequency	6dB bandwidth (MHz)	Limit (kHz)	Result
802.11b	2412 MHz	10.09	500	PASS
	2437 MHz	10.09	500	PASS
	2462 MHz	10.10	500	PASS
802.11g	2412 MHz	16.60	500	PASS
	2437 MHz	16.61	500	PASS
	2462 MHz	16.60	500	PASS
802.11n-HT20	2412 MHz	17.82	500	PASS
	2437 MHz	17.83	500	PASS
	2462 MHz	17.83	500	PASS
802.11b-HT40	2422 MHz	36.41	500	PASS
	2437 MHz	36.75	500	PASS
	2452 MHz	36.44	500	PASS
Test Mode	Frequency	6dB bandwidth (kHz)	Limit (kHz)	Result
BT LE	2402 MHz	699.40	500	PASS
	2440 MHz	699.00	500	PASS
	2480 MHz	693.10	500	PASS

**DongGuan Precise Testing Service Co., Ltd.**

Building D, Baoding Technology Park, Guangming Road 2, Guangming Community, Dongcheng District, Dongguan, Guangdong, China

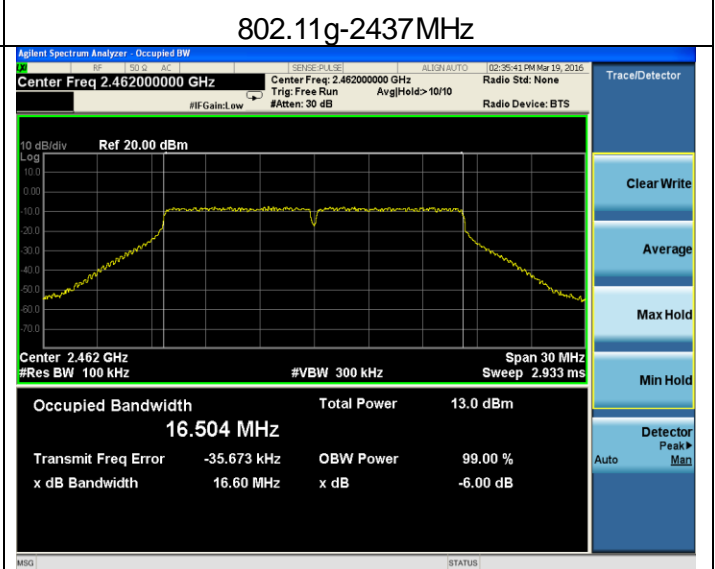
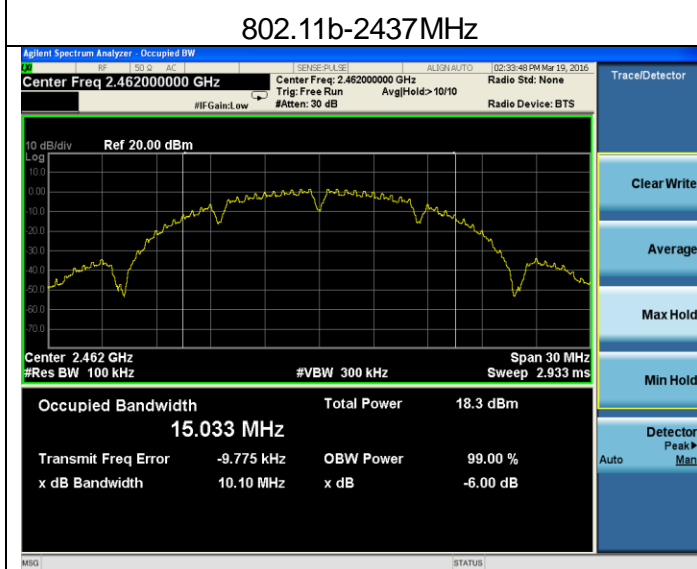
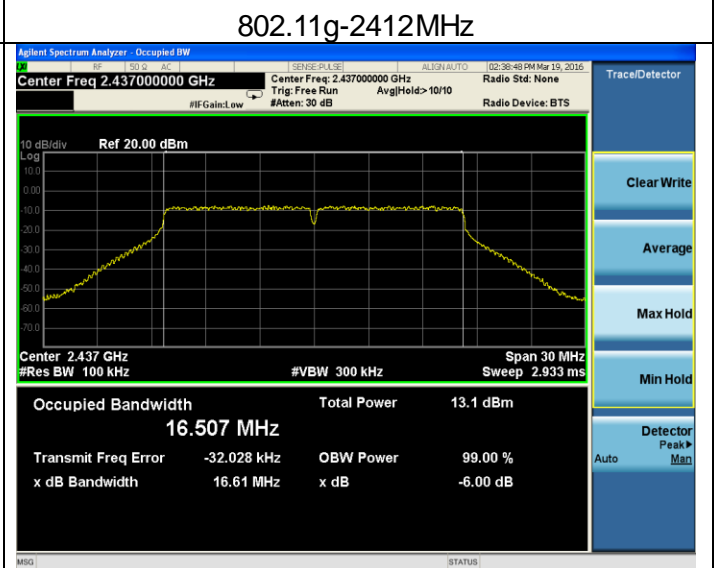
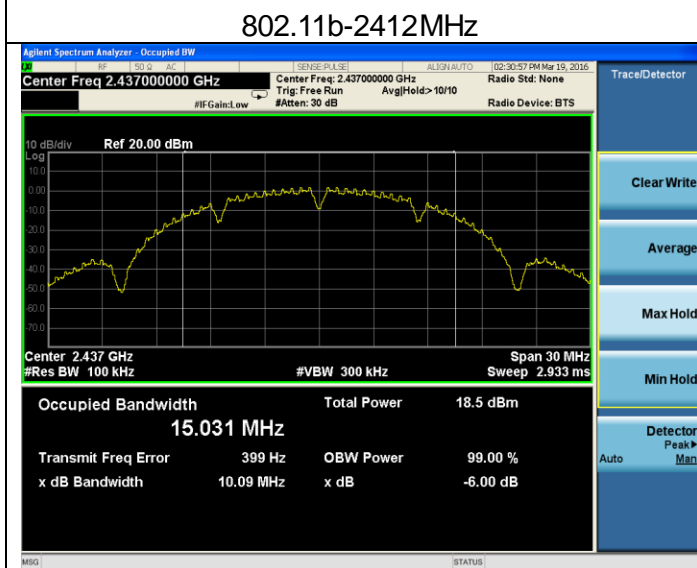

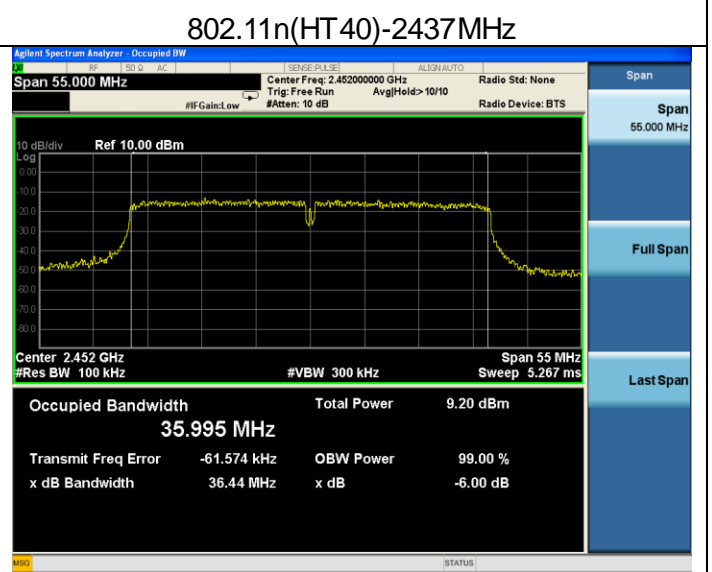
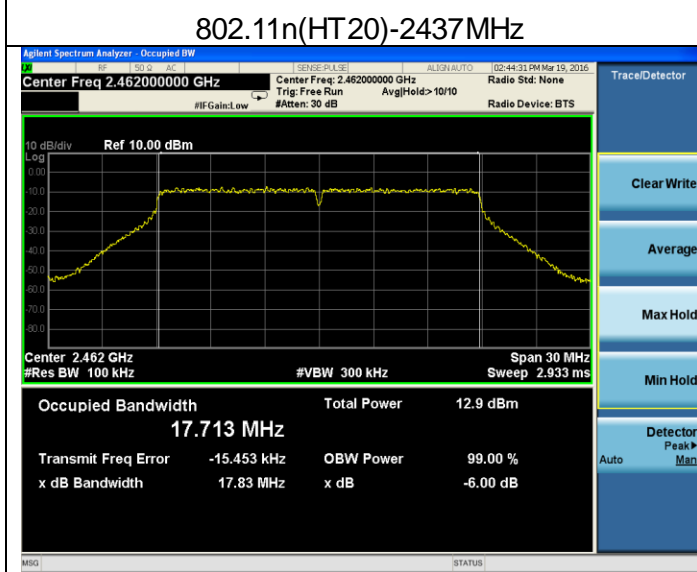
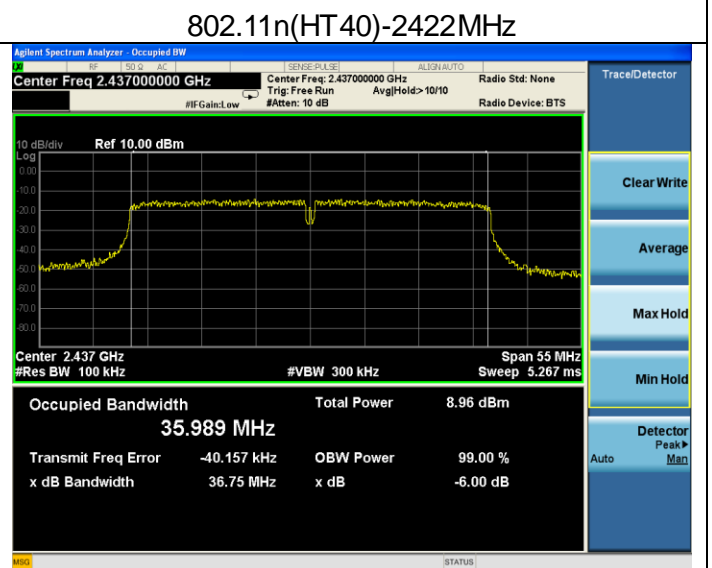
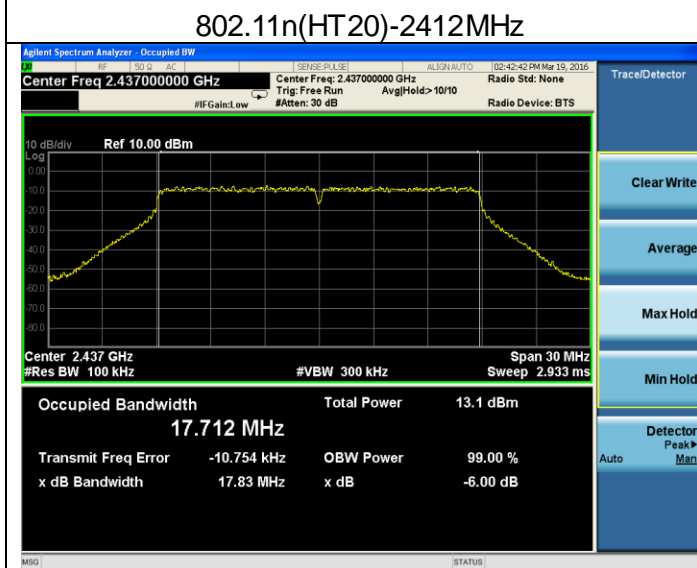
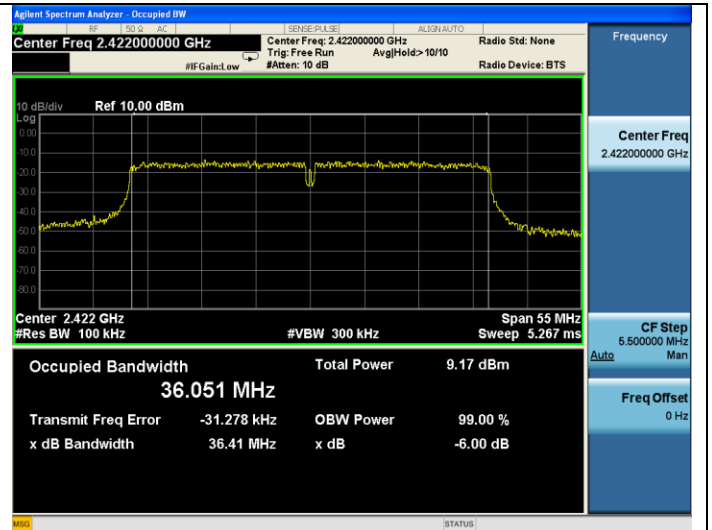
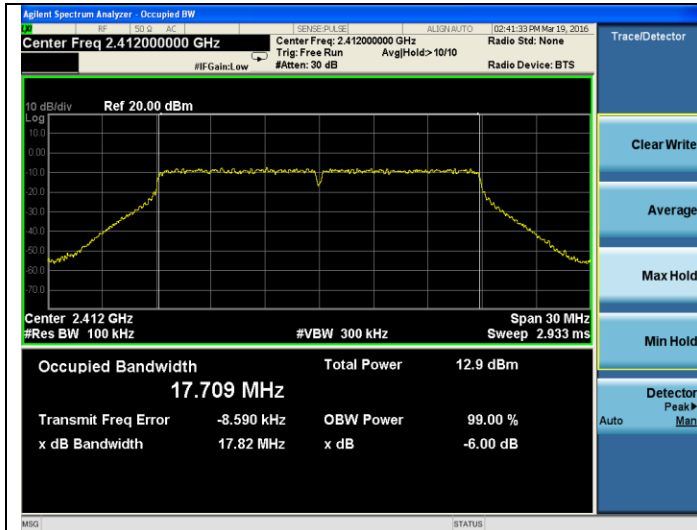

802.11n(HT20)-2462MHz

802.11n(HT40)-2452MHz



BT LE-2402MHz



BT LE-2440MHz



BT LE-2480MHz

**DongGuan Precise Testing Service Co., Ltd.**

Building D, Baoding Technology Park, Guangming Road 2, Guangming Community, Dongcheng District, Dongguan, Guangdong, China

Tel: 86-769-23368601

Fax: 86-769-23368602

http:// www.pts-testing.com

## 6. PEAK OUTPUT POWER TEST

### 6.1 APPLIED PROCEDURES / LIMIT

FCC Part15 (15.247) , Subpart C				
Section	Test Item	Limit	Frequency Range (MHz)	Result
15.247(b)(3)	Peak Output Power	1 watt or 30dBm	2400-2483.5	PASS

#### 6.1.1 TEST PROCEDURE

- a. The EUT was directly connected to the Power meter

#### 6.1.2 DEVIATION FROM STANDARD

No deviation.

#### 6.1.3 TEST SETUP



#### 6.1.4 EUT OPERATION CONDITIONS

The EUT tested system was configured as the statements of 2.4 Unless otherwise a special operating condition is specified in the follows during the testing.

### 6.1.5 TEST RESULTS

EUT :	Glasses Free 3D Gaming Tablets	Model Name :	X300
Temperature :	25 °C	Relative Humidity :	60%
Pressure :	1012 hPa	Test Voltage :	DC 3.80V
Test Mode :	TX b/g/n		

Test Mode	Frequency	Conducted Output Power(Peak)	LIMIT
	MHz	dBm	dBm
802.11b	2412	15.43	30
	2437	15.47	30
	2462	15.52	30
802.11g	2412	14.48	30
	2437	14.69	30
	2462	14.44	30
802.11n-HT20	2412	14.72	30
	2437	14.59	30
	2462	14.69	30
802.11b-HT40	2422	12.89	30
	2437	12.77	30
	2452	12.92	30
BT LE	2402	-1.933	30
	2440	-1.907	30
	2480	-2.362	30

NOTE: During the test the EUT is in 100% duty cycle transmitting.

## 7. CONDUCTED SPURIOUS EMISSIONS AND BAND EDGES TEST

### APPLICABLE STANDARD

According to §15.247 (d): In any 100 kHz bandwidth outside the frequency band in which the spread spectrum or digitally modulated intentional radiator is operating, the radio frequency power that is produced by the intentional radiator shall be at least 20 dB below that in the 100 kHz bandwidth within the band that contains the highest level of the desired power, based on either an RF conducted or a radiated measurement, provided the transmitter demonstrates compliance with the peak conducted power limits. If the transmitter complies with the conducted power limits based on the use of RMS averaging over a time interval, as permitted under paragraph (b)(3) of this section, the attenuation required under this paragraph shall be 30 dB instead of 20 dB. Attenuation below the general limits specified in §15.209(a) is not required. In addition, radiated emissions which fall in the restricted bands, as defined in §15.205(a), must also comply with the radiated emission limits specified in §15.209(a) (see §15.205(c)).

### TEST PROCEDURE

- a) Check the calibration of the measuring instrument using either an internal calibrator or a known signal from an external generator.
- b) Position the EUT without connection to measurement instrument. Turn on the EUT and connect its antenna terminal to measurement instrument via a low loss cable. Then set it to any one measured frequency within its operating range, and make sure the instrument is operated in its linear range.

For Conducted Spurious Emissions:

- c) The transmitter output is connected to a spectrum analyzer. The resolution bandwidth is set to 100 kHz. The video bandwidth is set to 300 kHz
- d) The spectrum from 9kHz to 25GHz is investigated with the transmitter set to the lowest, middle, and highest channels.

For Band Edges Test:

- e) Set RBW to 100 kHz and VBW of spectrum analyzer to 300 kHz with a convenient frequency span including 100 kHz bandwidth from band edge.
- f) Measure the highest amplitude appearing on spectral display and set it as a reference level. Plot the graph with marking the highest point and edge frequency.
- g) Repeat above procedures until all measured frequencies were complete.

### DongGuan Precise Testing Service Co., Ltd.

Building D, Baoding Technology Park, Guangming Road 2, Guangming Community, Dongcheng District, Dongguan, Guangdong, China



### 7.1 DEVIATION FROM STANDARD

No deviation.

### 7.2 TEST SETUP

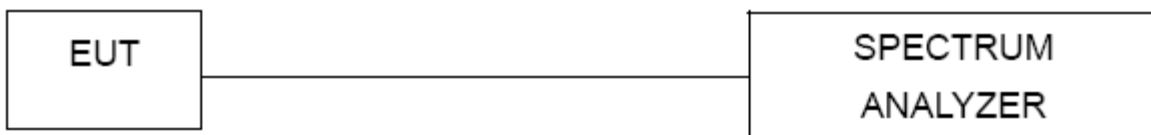

### 7.3 EUT OPERATION CONDITIONS

The EUT tested system was configured as the statements of 2.4 Unless otherwise a special operating condition is specified in the follows during the testing.

### 7.4 TEST RESULTS FOR CONDUCTED SPURIOUS EMISSIONS TEST

EUT :	Glasses Free 3D Gaming Tablets	Model Name :	X300
Temperature :	25 °C	Relative Humidity :	60%
Pressure :	1012 hPa	Test Voltage :	DC 3.80V

Test plot: Please refer to the following page.

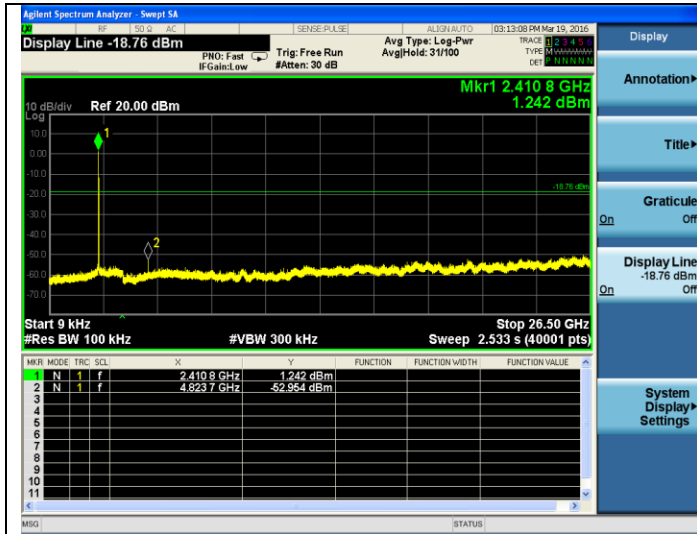

802.11b-2412MHz

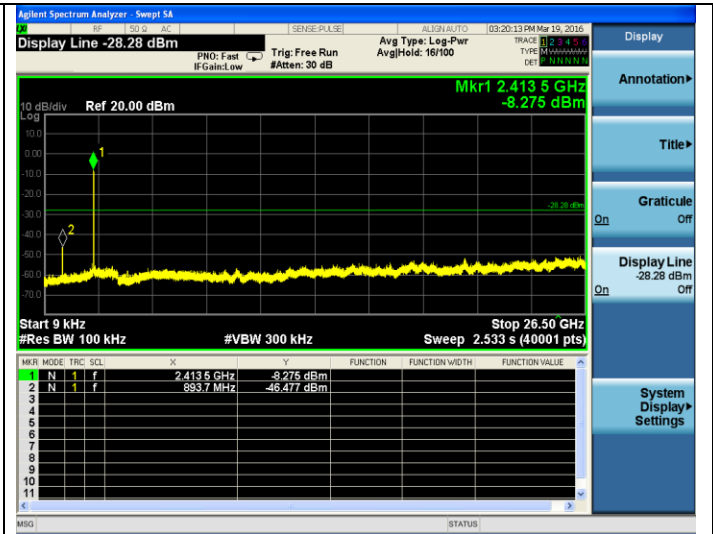

802.11g-2412MHz

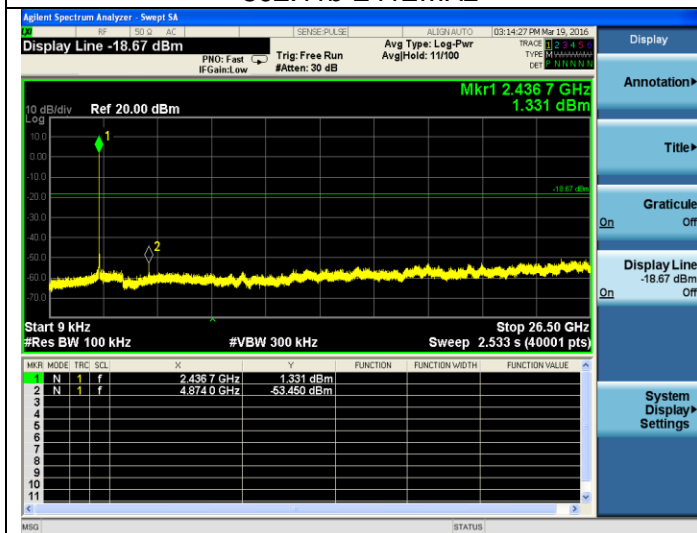

802.11b-2437MHz

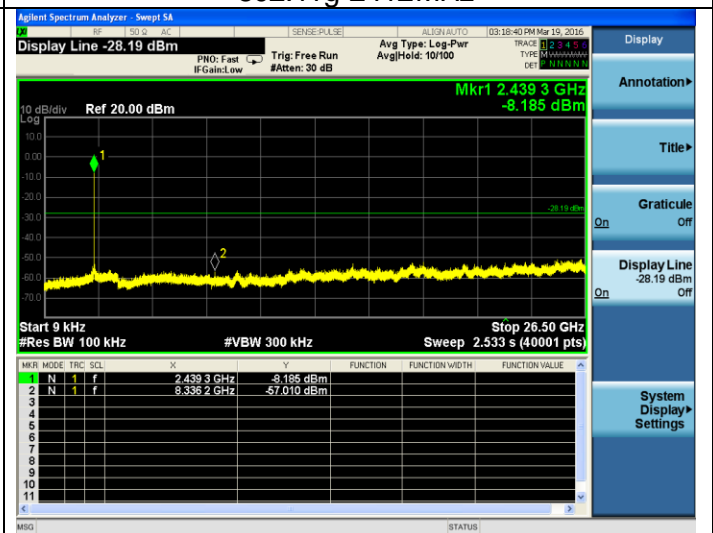

802.11g-2437MHz

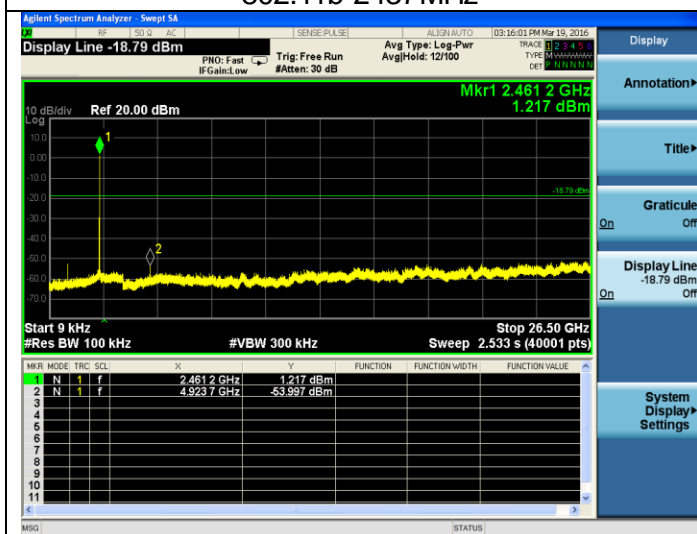

802.11b-2462MHz

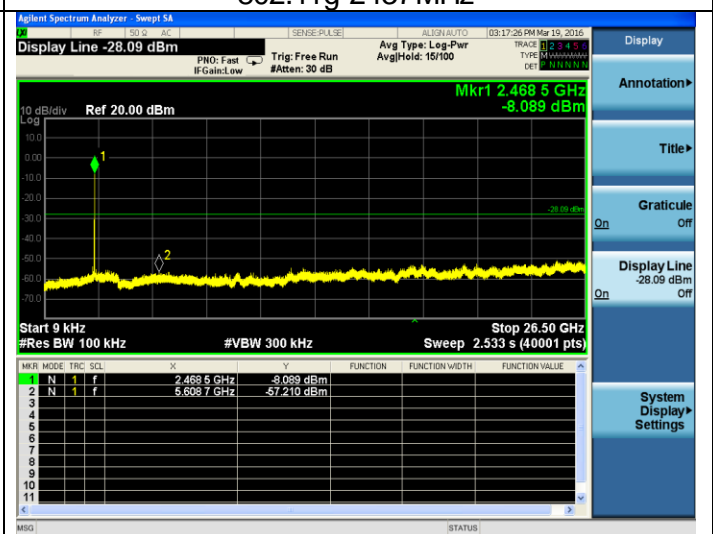

802.11g-2462MHz

**DongGuan Precise Testing Service Co., Ltd.**

Building D, Baoding Technology Park, Guangming Road 2, Guangming Community, Dongcheng District, Dongguan, Guangdong, China

Tel: 86-769-23368601

Fax: 86-769-23368602

http:// www.pts-testing.com

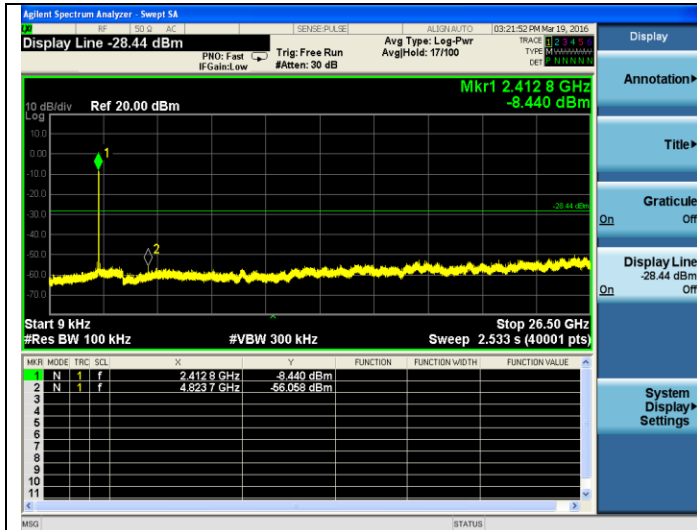

802.11n(HT20)-2412MHz

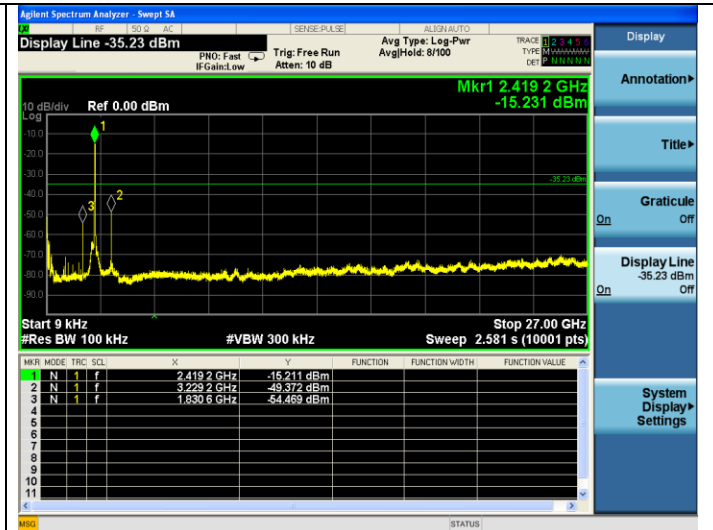

802.11n(HT40)-2422MHz

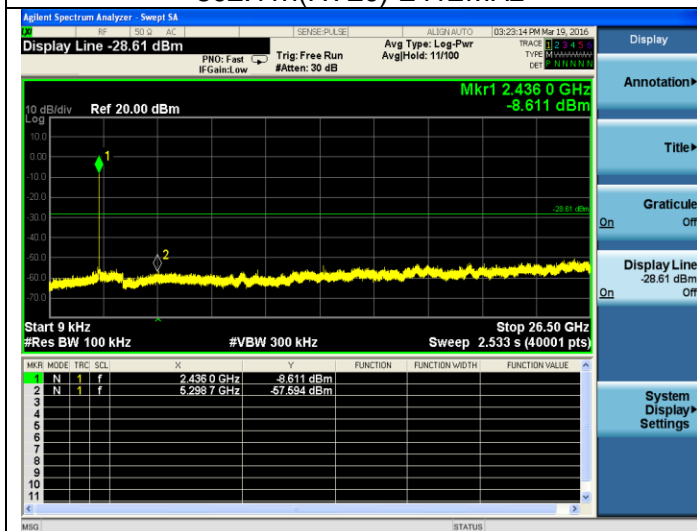

802.11n(HT20)-2437MHz

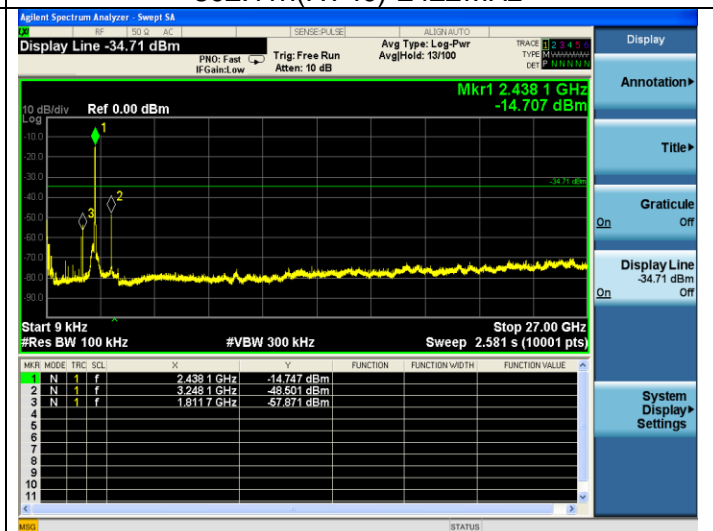

802.11n(HT40)-2437MHz

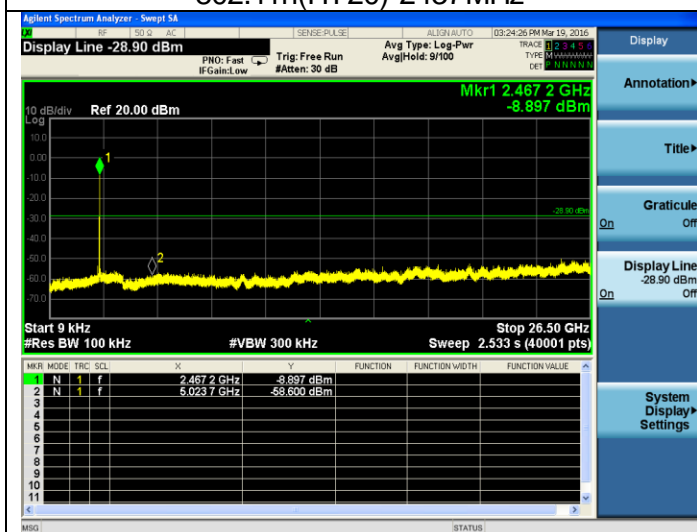

802.11n(HT20)-2462MHz

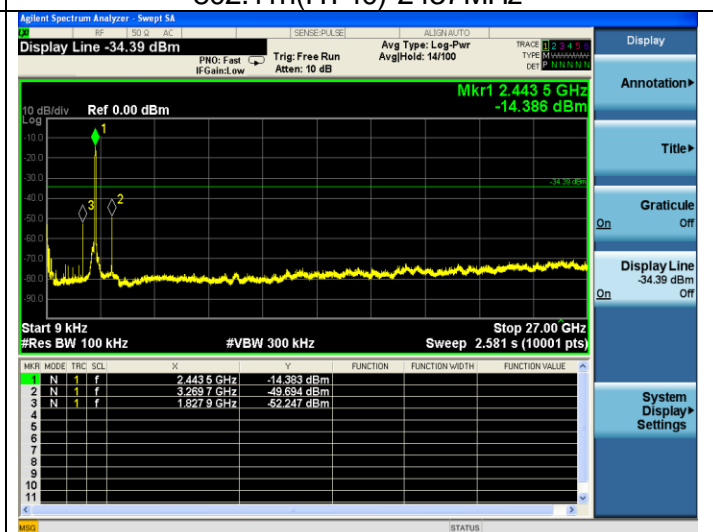

802.11n(HT40)-2452MHz

**DongGuan Precise Testing Service Co., Ltd.**

Building D, Baoding Technology Park, Guangming Road 2, Guangming Community, Dongcheng District, Dongguan, Guangdong, China

Tel: 86-769-23368601

Fax: 86-769-23368602

http:// www.pts-testing.com

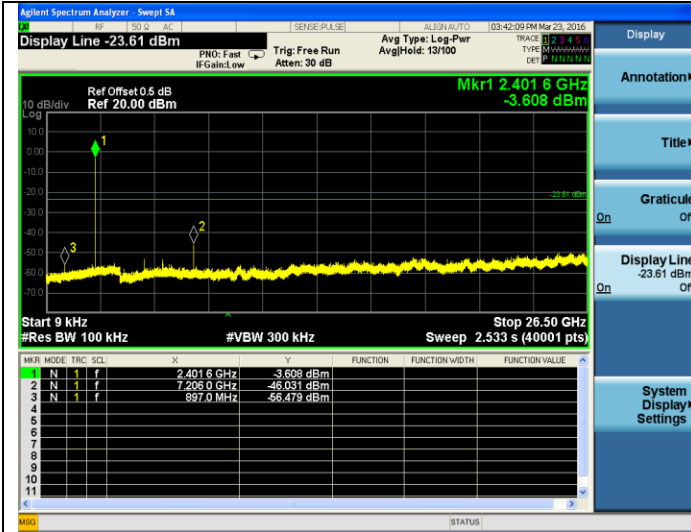

BT LE-2402MHz

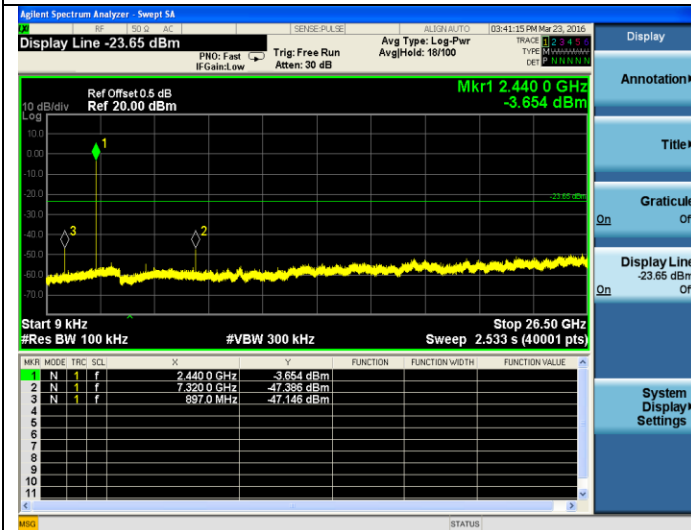

BT LE-2440MHz

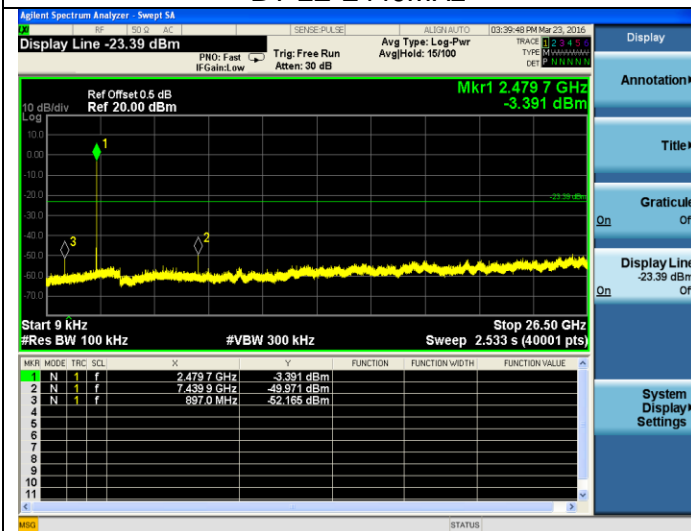

BT LE-2480MHz

### 7.5 TEST RESULTS FOR BAND EDGES TEST

EUT :	Glasses Free 3D Gaming Tablets	Model Name :	X300
Temperature :	25 °C	Relative Humidity :	60%
Pressure :	1012 hPa	Test Voltage :	DC 3.80V

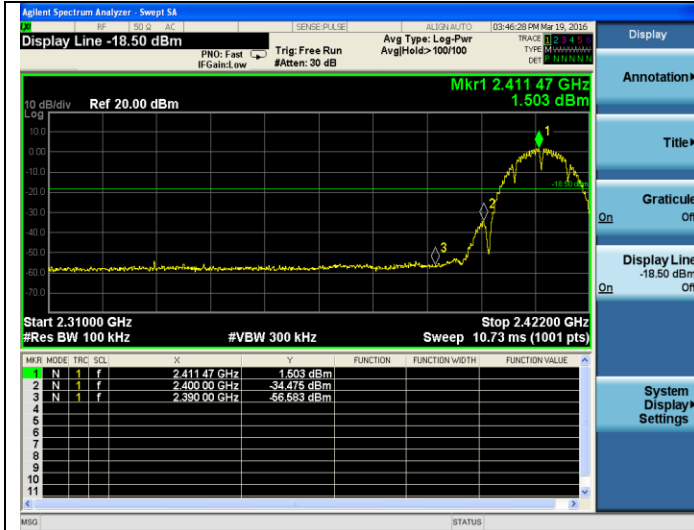

802.11b-2412MHz



802.11b-2462MHz

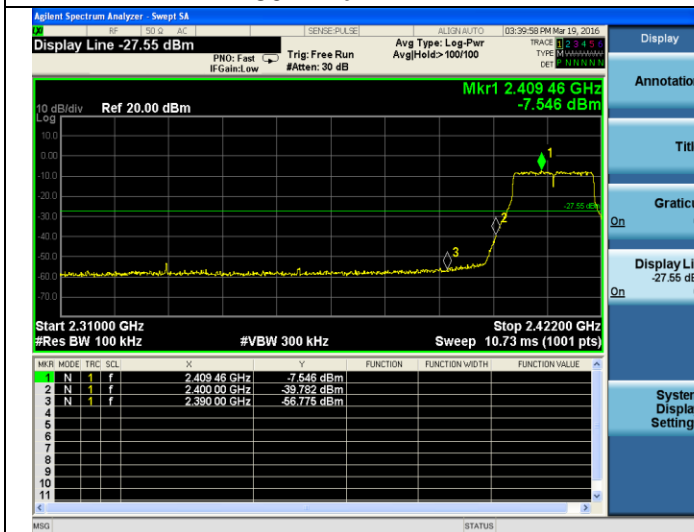

802.11g-2412MHz



802.11g-2462MHz

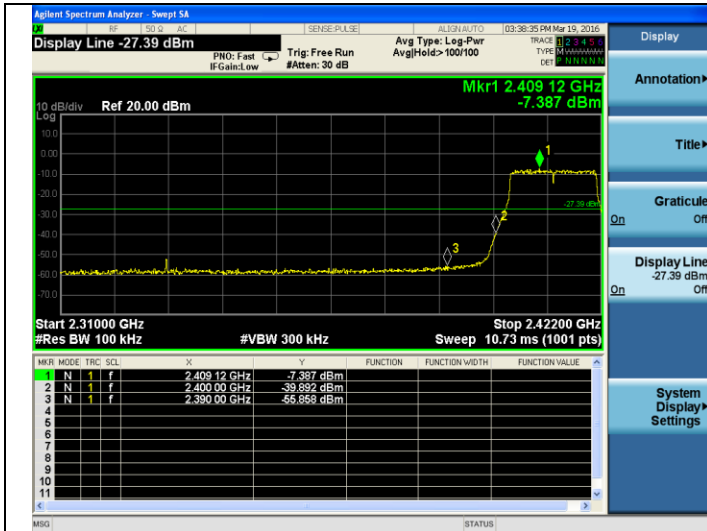

802.11n(HT20)-2412MHz



802.11n(HT20)-2462MHz

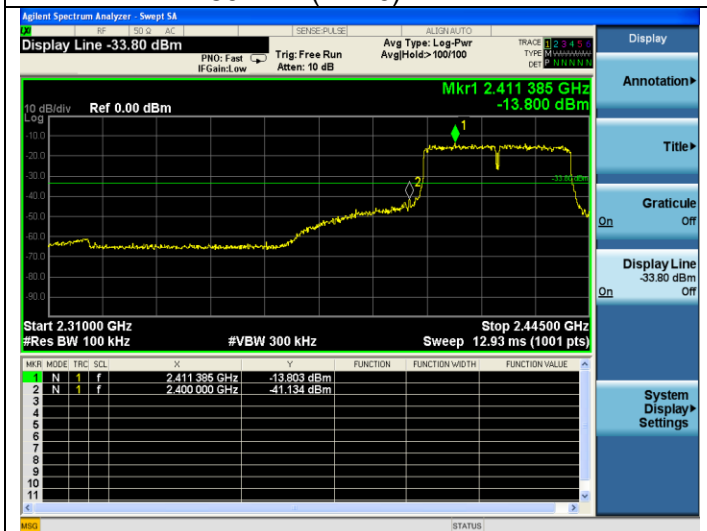

802.11n(HT40)-2422MHz

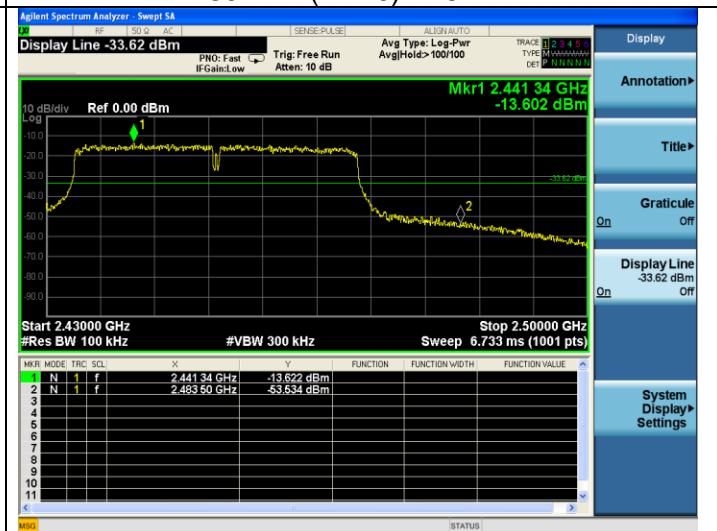

802.11n(HT40)-2452MHz

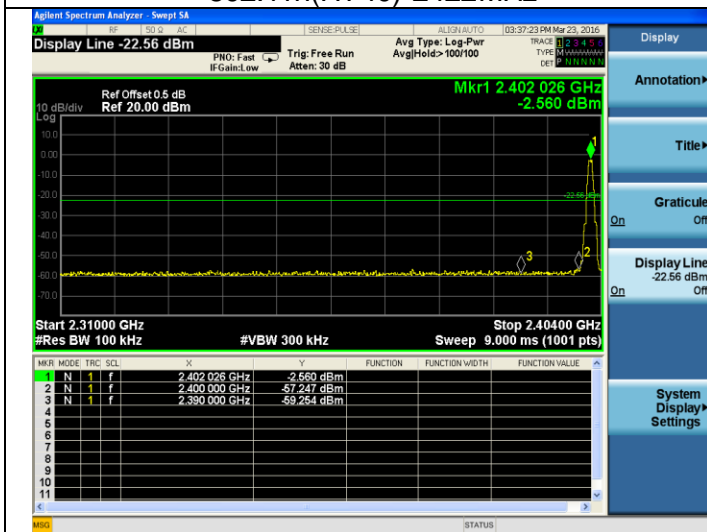

BT LE-2402MHz

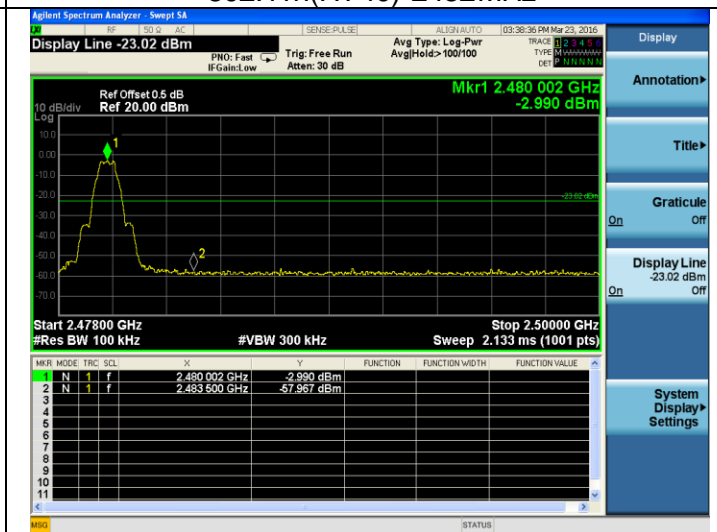

BT LE-2480MHz

## **8. ANTENNA REQUIREMENT**

### **8.1 STANDARD REQUIREMENT**

15.203 requirement: For intentional device, according to 15.203: an intentional radiator shall be designed to ensure that no antenna other than that furnished by the responsible party shall be used with the device.

### **8.2 EUT ANTENNA**

The EUT antenna is PIFA antenna and the gain is -1.50dBi. It's permanent attached antenna. It comply with the standard requirement.

## 9. EUT TEST PHOTO

### Radiated Measurement Photos

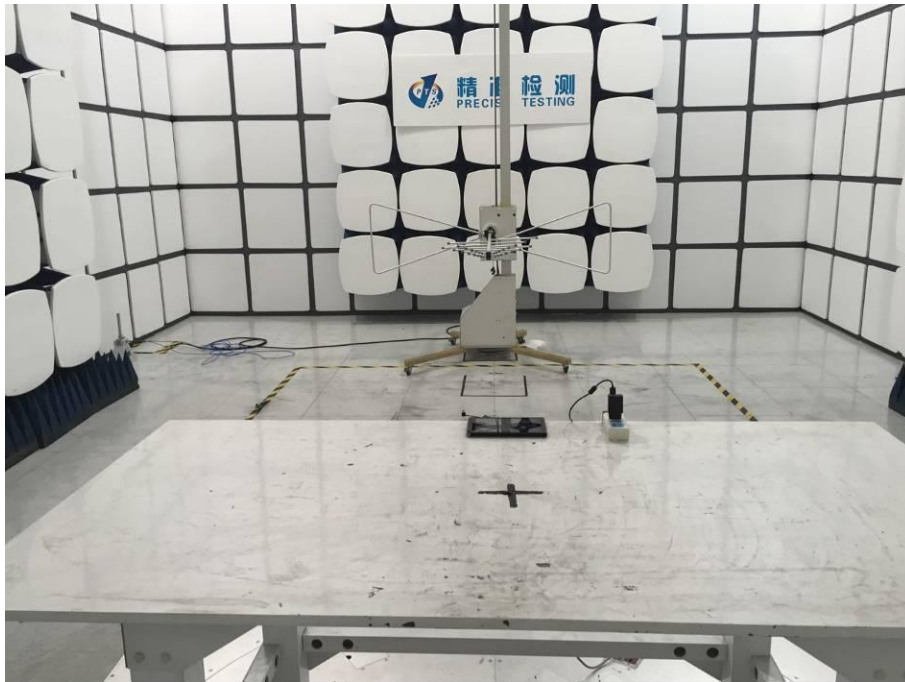

### Radiated Measurement Photos

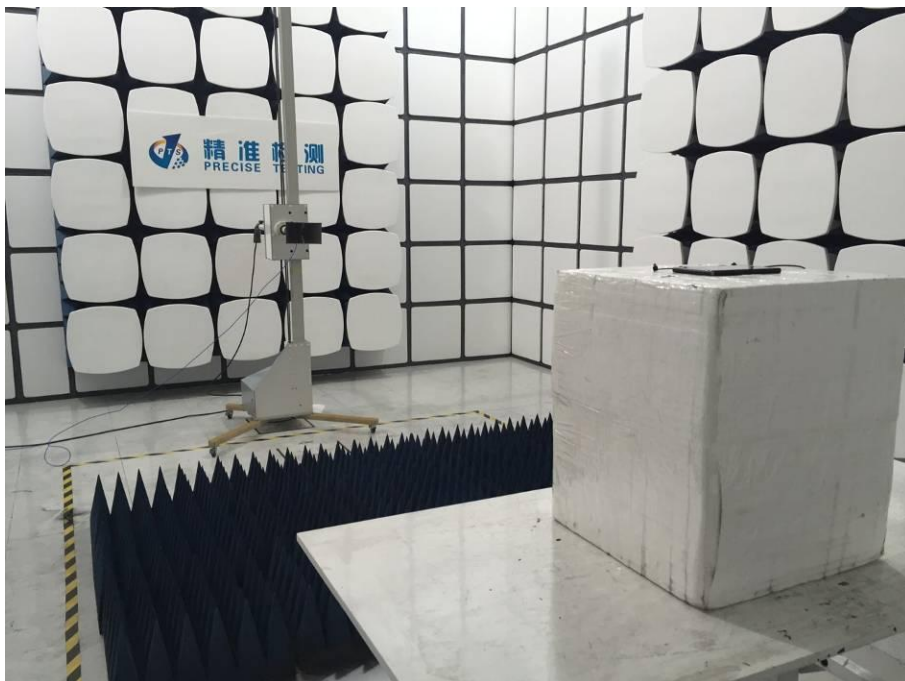

**DongGuan Precise Testing Service Co., Ltd.**

Building D, Baoding Technology Park, Guangming Road 2, Guangming Community, Dongcheng District, Dongguan, Guangdong, China

Tel: 86-769-23368601

Fax: 86-769-23368602

[http:// www.pts-testing.com](http://www.pts-testing.com)



### Conducted Measurement Photos



\*\*\*\*\*THE END REPORT\*\*\*\*\*