

FCC 47 CFR PART 15 SUBPART C

CERTIFICATION TEST REPORT

For

UHF RFID Reader Module

MODEL No.: HYM360

FCC ID: RVZH YM360

Trademark: Winnix

REPORT NO.: ES150410076E

ISSUE DATE: May 25, 2015

Prepared for

Winnix Technologies Co., Limited

4/F R2-B Building, Hi-tech Park, NanShan District, Shenzhen, Guangdong,
China

Prepared by

SHENZHEN EMTEK CO., LTD.

Bldg 69, Majialong Industry Zone, Nanshan District, Shenzhen,
Guangdong, China

TEL: 86-755-26954280

FAX: 86-755-26954282

Table of Contents

1	TEST RESULT CERTIFICATION	3
2	EUT TECHNICAL DESCRIPTION.....	4
3	SUMMARY OF TEST RESULT	5
4	TEST METHODOLOGY	6
4.1	GENERAL DESCRIPTION OF APPLIED STANDARDS.....	6
4.2	MEASUREMENT EQUIPMENT USED	6
4.3	DESCRIPTION OF TEST MODES.....	6
5	FACILITIES AND ACCREDITATIONS	8
5.1	FACILITIES	8
5.2	LABORATORY ACCREDITATIONS AND LISTINGS	8
6	TEST SYSTEM UNCERTAINTY	9
7	SETUP OF EQUIPMENT UNDER TEST	10
7.1	RADIO FREQUENCY TEST SETUP 1.....	10
7.2	RADIO FREQUENCY TEST SETUP 2.....	10
7.3	CONDUCTED EMISSION TEST SETUP.....	12
7.4	BLOCK DIAGRAM CONFIGURATION OF TEST SYSTEM.....	13
7.5	SUPPORT EQUIPMENT	13
8	TEST REQUIREMENTS	14
8.1	20DB BANDWIDTH	14
8.2	CARRIER FREQUENCY SEPARATION.....	17
8.3	NUMBER OF HOPPING FREQUENCIES	20
8.4	AVERAGE TIME OF OCCUPANCY (DWELL TIME)	22
8.5	MAXIMUM PEAK CONDUCTED OUTPUT POWER	24
8.6	CONDUCTED SUPRIOUS EMISSION	27
8.7	RADIATED SPURIOUS EMISSION.....	34
8.8	CONDUCTED EMISSION TEST.....	43
8.9	ANTENNA APPLICATION.....	46

1 TEST RESULT CERTIFICATION

Applicant:	Winnix Technologies Co., Limited 4/F R2-B Building, Hi-tech Park, NanShan District, Shenzhen, Guangdong, China
Manufacturer:	Winnix Technologies Co., Limited 4/F R2-B Building, Hi-tech Park, NanShan District, Shenzhen, Guangdong, China
Product Description:	UHF RFID Reader Module
Model Number:	HYM360
File Number:	ES150410076E
Date of Test:	May 10, 2015 or May 25, 2015

Measurement Procedure Used:

APPLICABLE STANDARDS	
STANDARD	TEST RESULT
FCC 47 CFR Part 2, Subpart J FCC 47 CFR Part 15, Subpart C	PASS

The above equipment was tested by SHENZHEN EMTEK CO., LTD. The test data, data evaluation, test procedures, and equipment configurations shown in this report were made in accordance with the procedures given in ANSI C63.10 (2013) and the energy emitted by the sample EUT tested as described in this report is in compliance with the requirements of FCC Rules Part 2 and Part 15.247

The test results of this report relate only to the tested sample identified in this report

Date of Test : May 10, 2015 or May 25, 2015

Prepared by : Joe Xia
 Joe Xia /Editor

Reviewer : Jack Li
 Jack Li /Supervisor

Approve & Authorized Signer : Lisa Wang
 Lisa Wang/Manager

2 EUT TECHNICAL DESCRIPTION

Characteristics	Description
Device Type	RFID
Modulation:	ASK
Operating Frequency Range(s):	902.75-927.25MHz
Number of Channels:	50
Transmit Power Max:	26.633dBm
Antenna Type :	External Antenna
Antenna Gain:	9.0dBi;
Power supply:	DC 12V

Note: for more details, please refer to the User's manual of the EUT.

3 SUMMARY OF TEST RESULT

FCC Part Clause	Test Parameter	Verdict	Remark
15.247(a)(1)	20 dB Bandwidth	PASS	
15.247(a)(1)	Carrier Frequency Separation	PASS	
15.247(a)(1)	Number of Hopping Frequencies	PASS	
15.247(a)(1)	Average Time of Occupancy (Dwell Time)	PASS	
15.247(b)(1)	Maximum Peak Conducted Output Power	PASS	
15.247(c)	Conducted Spurious Emissions	PASS	
15.247(d) 15.209	Radiated Spurious Emissions	PASS	
15.207	Conducted Emission	PASS	
15.247(b)	Antenna Application	PASS	
NOTE1: N/A (Not Applicable)			

RELATED SUBMITTAL(S) / GRANT(S):

This submittal(s) (test report) is intended for FCC ID: RVZHYM360 filing to comply with Section 15.247 of the FCC Part 15, Subpart C Rules.

The FHSS system is compliance with Subpart B is authorized under a DOC procedure

4 TEST METHODOLOGY

4.1 GENERAL DESCRIPTION OF APPLIED STANDARDS

According to its specifications, the EUT must comply with the requirements of the following standards:
 FCC 47 CFR Part 2, Subpart J
 FCC 47 CFR Part 15, Subpart C
 DA 00-705

4.2 MEASUREMENT EQUIPMENT USED

4.2.1 Conducted Emission Test Equipment

EQUIPMENT TYPE	MFR	MODEL NUMBER	SERIAL NUMBER	LAST CAL.
Test Receiver	Rohde & Schwarz	ESCS30	828985/018	05/17/2015
L.I.S.N.	Schwarzbeck	NNLK8129	8129203	05/17/2015
50Ω Coaxial Switch	Anritsu	MP59B	M20531	N/A
Pulse Limiter	Rohde & Schwarz	ESH3-Z2	100006	05/17/2015
Voltage Probe	Rohde & Schwarz	TK9416	N/A	05/17/2015
I.S.N	Rohde & Schwarz	ENY22	1109.9508.02	05/17/2015

4.2.2 Radiated Emission Test Equipment

EQUIPMENT TYPE	MFR	MODEL NUMBER	SERIAL NUMBER	LAST CAL.
EMI Test Receiver	Rohde & Schwarz	ESU	1302.6005.26	05/17/2015
Pre-Amplifier	HP	8447D	2944A07999	05/17/2015
Bilog Antenna	Schwarzbeck	VULB9163	142	05/17/2015
Loop Antenna	ARA	PLA-1030/B	1029	05/17/2015
Horn Antenna	Schwarzbeck	BBHA 9170	BBHA9170399	05/17/2015
Horn Antenna	Schwarzbeck	BBHA 9120	D143	05/17/2015
Cable	Schwarzbeck	AK9513	ACRX1	05/17/2015
Cable	Rosenberger	N/A	FP2RX2	05/17/2015
Cable	Schwarzbeck	AK9513	CRPX1	05/17/2015
Cable	Schwarzbeck	AK9513	CRRX2	05/17/2015

4.2.3 Radio Frequency Test Equipment

EQUIPMENT TYPE	MFR	MODEL NUMBER	SERIAL NUMBER	LAST CAL.
Spectrum Analyzer	Agilent	E4407B	88156318	05/17/2015
Power meter	Anritsu	ML2495A	0824006	05/17/2015
Power sensor	Anritsu	MA2411B	0738172	05/17/2015
Spectrum Analyzer	Agilent	N9010A	My53470879	05/17/2015

Remark: Each piece of equipment is scheduled for calibration once a year.

4.3 DESCRIPTION OF TEST MODES

The EUT has been tested under its typical operating condition.

The EUT configuration for testing is installed on RF field strength measurement to meet the Commissions requirement and operating in a manner which intends to maximize its emission characteristics in a continuous normal application.

The Transmitter was operated in the normal operating mode. The TX frequency was fixed which was for the purpose of the measurements.

Test of channel included the lowest and middle and highest frequency to perform the test, then record on this report.

Those channels (902.75MHz, 915.25MHz, 927.25MHz) were used for all test.

Pre-defined engineering program for regulatory testing used to control the EUT for staying in continuous transmitting and receiving mode is programmed.

Frequency and Channel list for the EUT:

Channel	Frequency (MHz)	Channel	Frequency (MHz)	Channel	Frequency (MHz)
0	902.75	24	914.75
1	903.25	25	915.25	47	926.25
2	903.75	26	915.75	48	926.75
...	49	927.25

Note: $f_c = 902.75\text{MHz} + k * 0.5\text{MHz}$ $k(\text{Channel Number}) = 0$ to 49

Test Frequency and channel for the EUT:

Lowest Frequency		Middle Frequency		Highest Frequency	
Channel	Frequency (MHz)	Channel	Frequency (MHz)	Channel	Frequency (MHz)
0	902.75	25	915.25	49	927.25

5 FACILITIES AND ACCREDITATIONS

5.1 FACILITIES

All measurement facilities used to collect the measurement data are located at

Bldg 69, Majialong Industry Zone District, Nanshan District, Shenzhen, China

The sites are constructed in conformance with the requirements of ANSI C63.7, ANSI C63.10 and CISPR Publication 22.

5.2 LABORATORY ACCREDITATIONS AND LISTINGS

Site Description

EMC Lab.

- : Accredited by CNAS, 2013.10.29
The certificate is valid until 2016.10.28
The Laboratory has been assessed and proved to be in compliance with CNAS-CL01: 2006(identical to ISO/IEC17025: 2005)
The Certificate Registration Number is L2291
- : Accredited by TUV Rheinland Shenzhen, 2010.5.25
The Laboratory has been assessed according to the requirements ISO/IEC 17025.
- : Accredited by FCC, July 24, 2013
The Certificate Registration Number is 406365.
- : Accredited by FCC, April 17, 2013
The Certificate Registration Number is 709623.
- : Accredited by Industry Canada, November 29, 2012
The Certificate Registration Number is 4480A

6 TEST SYSTEM UNCERTAINTY

The following measurement uncertainty levels have been estimated for tests performed on the apparatus:

Parameter	Uncertainty
Radio Frequency	$\pm 1 \times 10^{-5}$
Maximum Peak Output Power Test	$\pm 1.0\text{dB}$
Conducted Emissions Test	$\pm 2.0\text{dB}$
Radiated Emission Test	$\pm 2.0\text{dB}$
Occupied Bandwidth Test	$\pm 1.0\text{dB}$
Band Edge Test	$\pm 3\text{dB}$
All emission, radiated	$\pm 3\text{dB}$
Antenna Port Emission	$\pm 3\text{dB}$
Temperature	$\pm 0.5^{\circ}\text{C}$
Humidity	$\pm 3\%$

Measurement Uncertainty for a level of Confidence of 95%

7 SETUP OF EQUIPMENT UNDER TEST

7.1 RADIO FREQUENCY TEST SETUP 1

The RFID component's antenna ports(s) of the EUT are connected to the measurement instrument per an appropriate attenuator. The EUT is controlled by PC/software to emit the specified signals for the purpose of measurements.

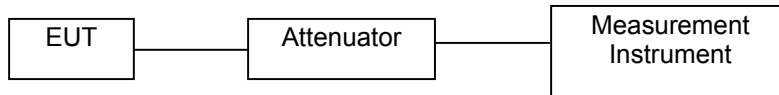

7.2 RADIO FREQUENCY TEST SETUP 2

The test site semi-anechoic chamber has met the requirement of NSA tolerance 4 dB according to the standards: ANSI C63.10. The test distance is 3m. The setup is according to the requirements in Section 13.1.4.1 of ANSI C63.10-2013 and CAN/CSA-CEI/IEC CISPR 22.

Below 30MHz:

The EUT is placed on a turntable 0.8 meters above the ground in the chamber, 3 meter away from the antenna (loop antenna). The Antenna should be positioned with its plane vertical at the specified distance from the EUT and rotated about its vertical axis for maximum response at each azimuth about the EUT. The center of the loop shall be 1 m above the ground. For certain applications, the loop antenna plane may also need to be positioned horizontally at the specified distance from the EUT.

Above 30MHz:

The EUT is placed on a turntable 0.8 meters above the ground in the chamber, 3 meter away from the antenna. The maximal emission value is acquired by adjusting the antenna height, polarisation and turntable azimuth. Normally, the height range of antenna is 1 m to 4 m, the azimuth range of turntable is 0° to 360°, and the receive antenna has two polarizations Vertical (V) and Horizontal (H).

Above 1GHz:

The EUT is placed on a turntable 1.5 meters above the ground in the chamber, 3 meter away from the antenna. The maximal emission value is acquired by adjusting the antenna height, polarisation and turntable azimuth. Normally, the height range of antenna is 1 m to 4 m, the azimuth range of turntable is 0° to 360°, and the receive antenna has two polarizations Vertical (V) and Horizontal (H).

(a) Radiated Emission Test Set-Up, Frequency Below 30MHz

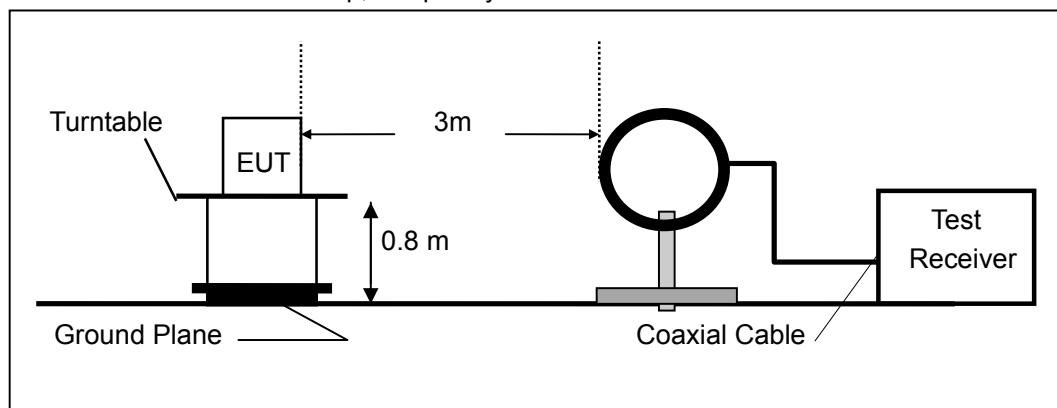

(b) Radiated Emission Test Set-Up, Frequency Below 1000MHz

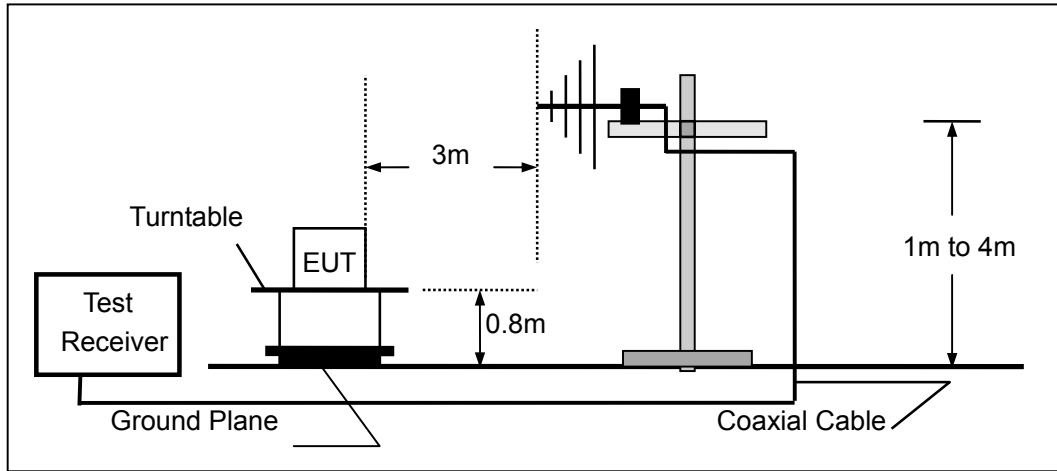

(c) Radiated Emission Test Set-Up, Frequency above 1000MHz

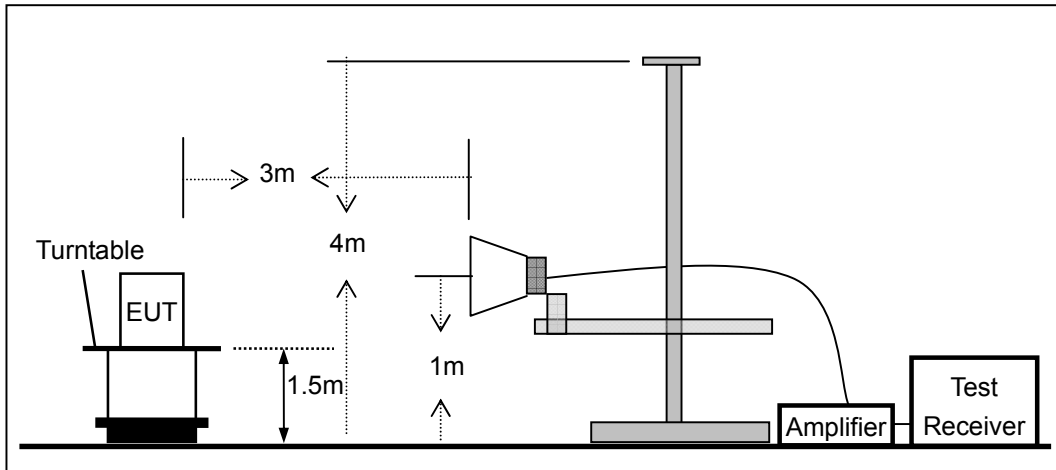

7.3 CONDUCTED EMISSION TEST SETUP

The mains cable of the EUT (UHF RFID Reader Module) must be connected to LISN. The LISN shall be placed 0.8 m from the boundary of EUT and bonded to a ground reference plane for LISN mounted on top of the ground reference plane. This distance is between the closest points of the LISN and the EUT. All other units of the EUT and associated equipment shall be at least 0.8m from the LISN.

Ground connections, where required for safety purposes, shall be connected to the reference ground point of the LISN and, where not otherwise provided or specified by the manufacturer, shall be of same length as the mains cable and run parallel to the mains connection at a separation distance of not more than 0.8 m.

According to the requirements in Section 13.1.4.1 of ANSI C63.10-2013 Conducted emissions from the EUT measured in the frequency range between 0.15 MHz and 30 MHz using CISPR Quasi-Peak and average detector mode.

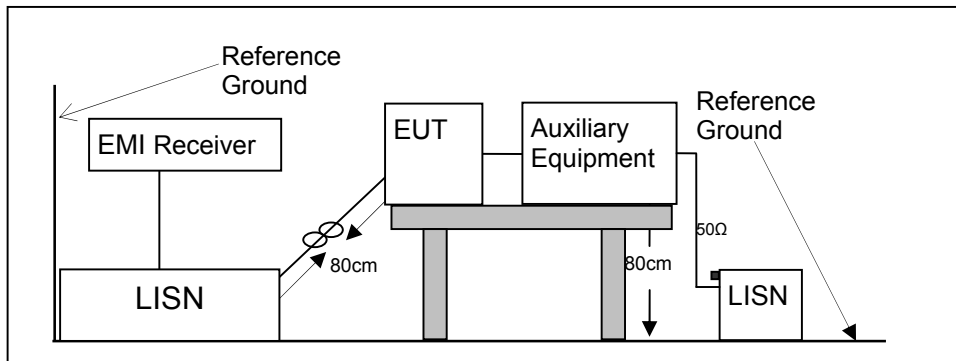

7.4 BLOCK DIAGRAM CONFIGURATION OF TEST SYSTEM

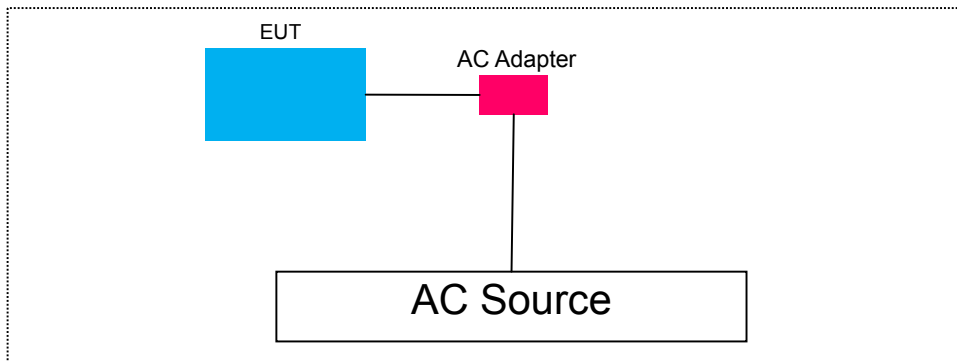

7.5 SUPPORT EQUIPMENT

Item	Equipment	Mfr/Brand	Model/Type No.	FCC ID	Note
1.	Adapter	WEI WY	WW-111	N/A	N/A

Notes:

1. All the equipment/cables were placed in the worst-case configuration to maximize the emission during the test.
2. Grounding was established in accordance with the manufacturer's requirements and conditions for the intended use.

8 TEST REQUIREMENTS

8.1 20DB BANDWIDTH

8.1.1 Applicable Standard

According to FCC Part 15.247(a)(1) and DA 00-705

8.1.2 Conformance Limit

No limit requirement.

8.1.3 Test Configuration

Test according to clause 7.1 radio frequency test setup 1

8.1.4 Test Procedure

The EUT was operating in RFID mode and controlled its channel. Printed out the test result from the spectrum by hard copy function.

The RF output of EUT was connected to the spectrum analyzer by RF cable and attenuator. The path loss was compensated to the results for each measurement.

Set to the maximum power setting and enable the EUT transmit continuously

Set RBW \geq 1% of the 20 dB bandwidth(10KHz)

Set the video bandwidth (VBW) \geq RBW(30KHz).

Set Span= approximately 2 to 3 times the 20 dB bandwidth

Set Detector = Peak.

Set Trace mode = max hold.

Set Sweep = auto couple.

The EUT should be transmitting at its maximum data rate. Allow the trace to stabilize. Use the marker-to-peak function to set the marker to the peak of the emission. Use the marker-delta function to measure 20 dB down one side of the emission. Reset the markerdelta function, and move the marker to the other side of the emission, until it is (as close as possible to) even with the reference marker level. The marker-delta reading at this point is the 20 dB bandwidth of the emission.

If this value varies with different modes of operation (e.g., data rate, modulation format, etc.), repeat this test for each variation.

Measure and record the results in the test report.

Test Results

Temperature:	24 °C	Test Date:	May 20, 2015
Humidity:	53 %	Test By:	King Kong

Modulation Mode	Channel Number	Channel Frequency (MHz)	Measurement Bandwidth (kHz)	Limit (kHz)	Verdict
ASK	00	902.75	93.79	N/A	PASS
	25	915.25	91.55	N/A	PASS
	49	927.25	92.87	N/A	PASS

Note: N/A (Not Applicable)

Test Model 20dB Bandwidth
 RFID
 Channel 0: 902.75MHz ASK Modulation

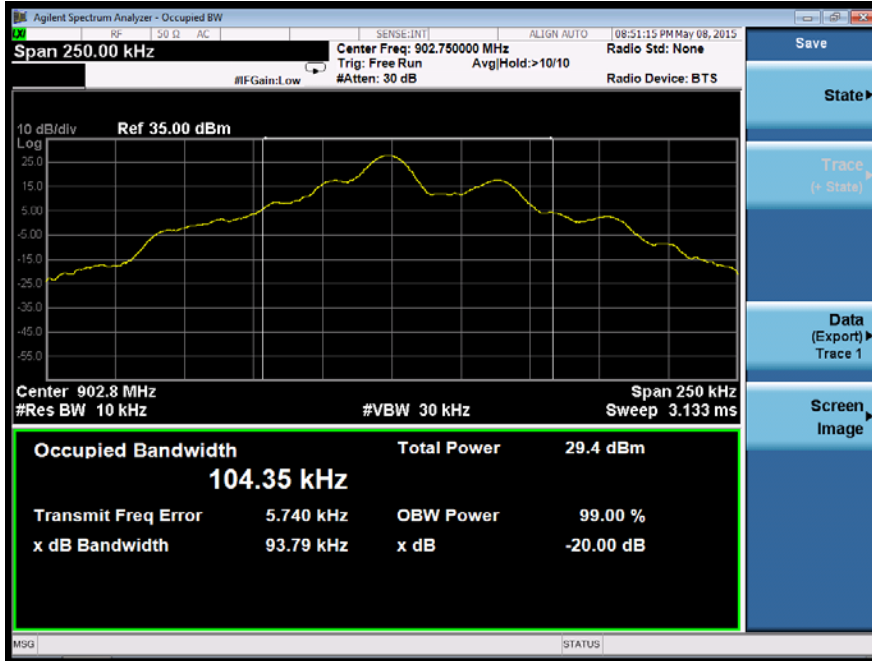

Test Model 20dB Bandwidth
 RFID
 Channel 25: 915.25MHz ASK Modulation

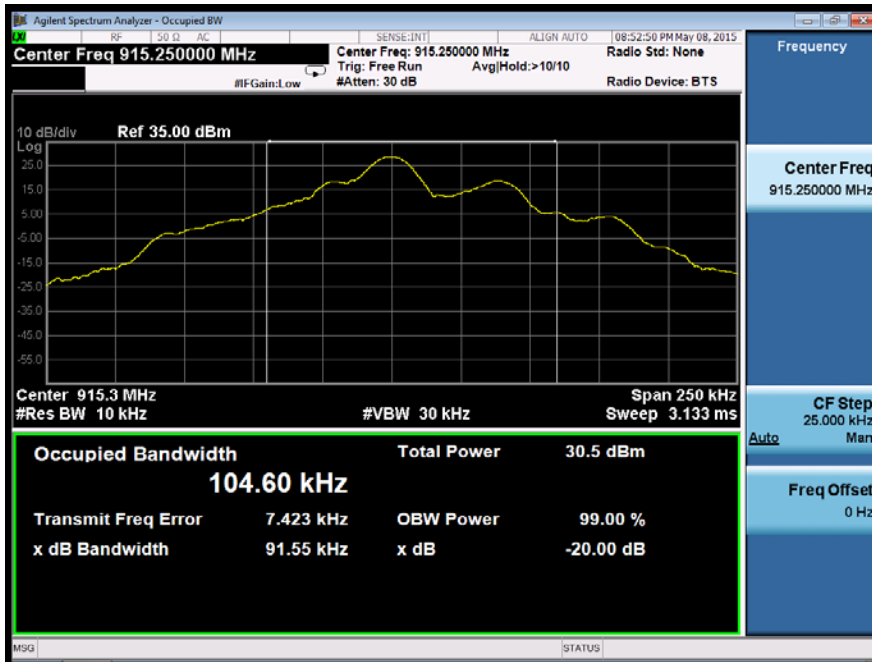

Test Model 20dB Bandwidth
 RFID
 Channel 49: 927.25MHz ASK Modulation

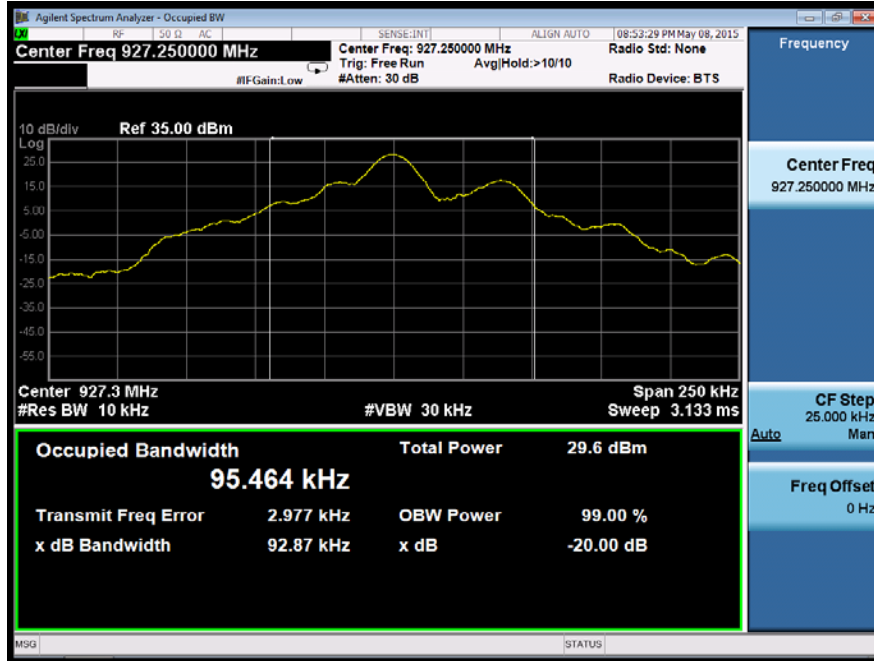

8.2 CARRIER FREQUENCY SEPARATION

8.2.1 Applicable Standard

According to FCC Part 15.247(a)(1) and DA 00-705

8.2.2 Conformance Limit

Frequency hopping systems operating in the 902.75-927.25MHz band shall have hopping channel carrier frequencies separated by a minimum of 25kHz or the 20dB bandwidth of the hopping channel, whichever is greater.

In case of an output power less than 125mW, the frequency hopping system may have channels separated by a minimum of 25kHz or two-thirds of the 20dB bandwidth of the hopping channel, whichever is greater.

8.2.3 Test Configuration

Test according to clause 7.1 radio frequency test setup 1

8.2.4 Test Procedure

- According to FCC Part15.247(a)(1)
- The EUT must have its hopping function enabled. Use the following spectrum analyzer settings:
- Set the RBW \geq 1% of the span(10KHz).
- Set the VBW \geq RBW(30KHz).
- Set the span = wide enough to capture the peaks of two adjacent channels
- Set Sweep time = auto couple.
- Set Detector = peak.
- Set Trace mode = max hold.
- Allow the trace to stabilize. Use the marker-delta function to determine the separation between the peaks of the adjacent channels. The limit is specified in one of the subparagraphs of this Section. Submit this plot.

Test Results

Temperature:	24 °C	Test Date:	May 20, 2015
Humidity:	53 %	Test By:	King Kong

Modulation Mode	Channel Number	Channel Frequency (MHz)	Measurement Bandwidth (kHz)	Limit (kHz)	Verdict
ASK	0	902.75	500.00	>93.79	PASS
	25	915.25	500.00	>91.55	PASS
	49	927.25	500.00	>92.87	PASS

Note: Limit = 20dB bandwidth, if it is greater than 25kHz and the output power is less than 1W (30dBm).

Test Model

Carrier Frequency Separation
 RFID
 Channel 0: 902.75MHz

ASK Modulation

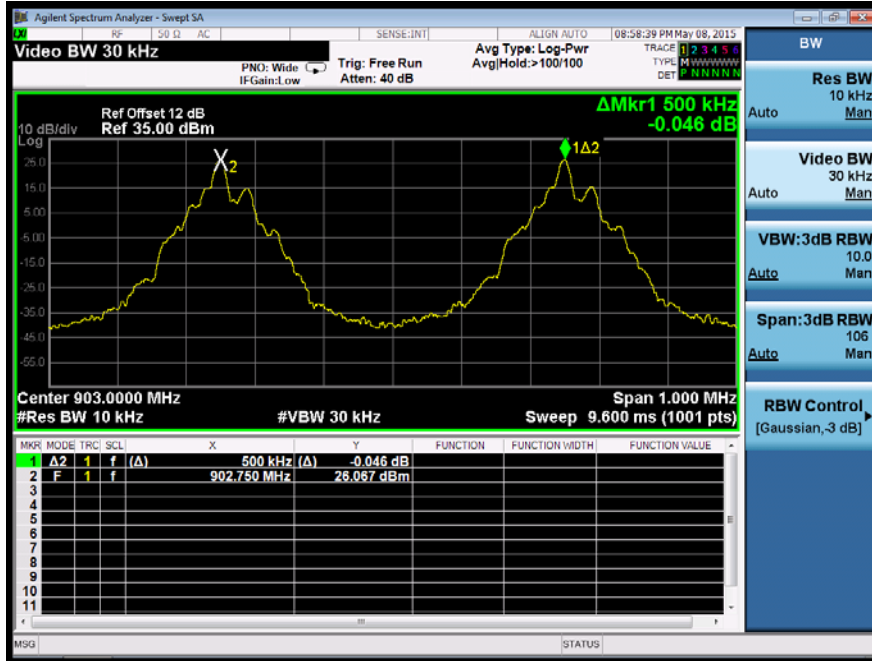

Test Model

Carrier Frequency Separation
 RFID
 Channel 25: 915.25MHz

ASK Modulation

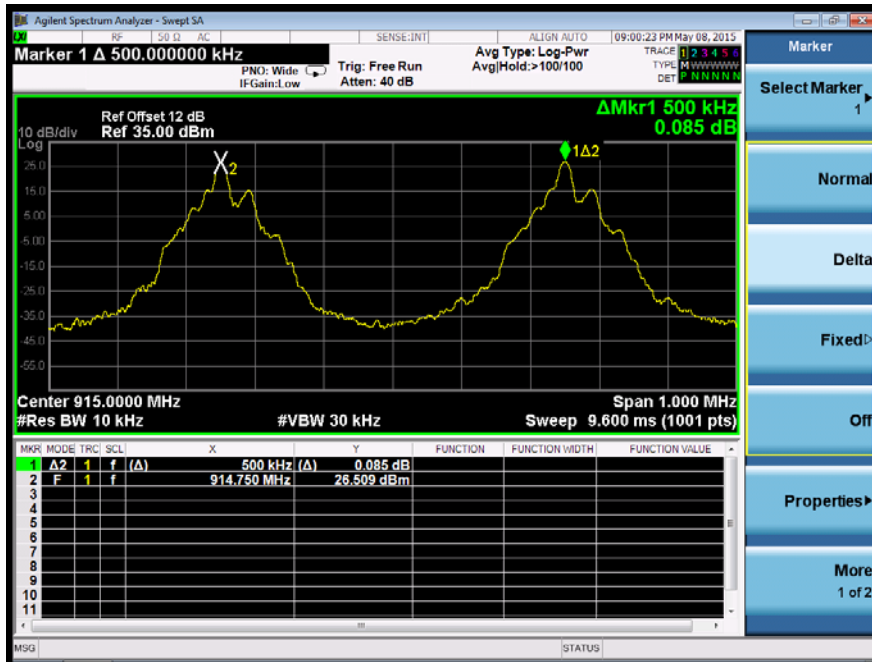

Test Model

Carrier Frequency Separation

RFID

Channel 49: 927.25MHz

ASK Modulation

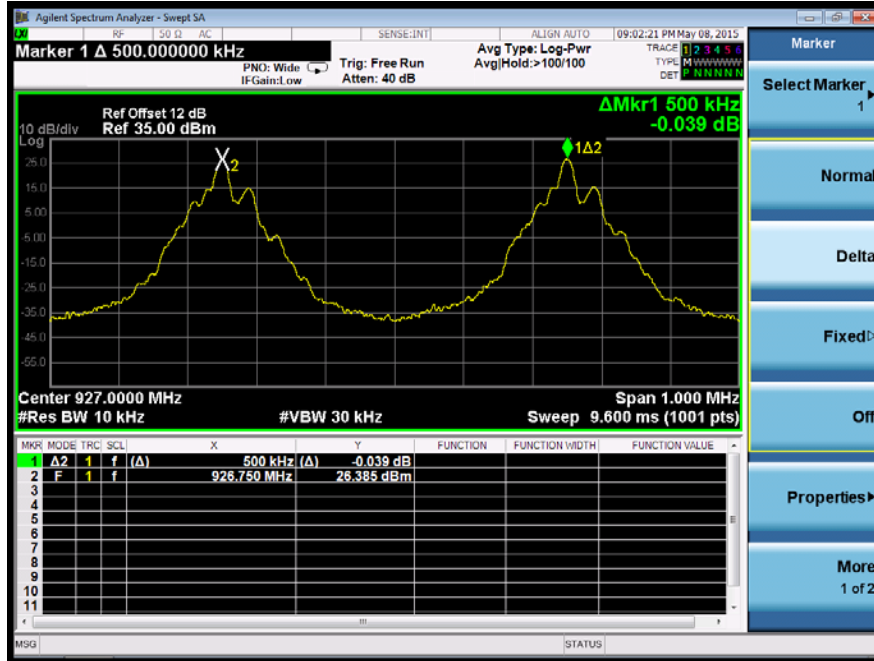

8.3 NUMBER OF HOPPING FREQUENCIES

8.3.1 Applicable Standard

According to FCC Part 15.247(a)(1) (iii)and DA 00-705

8.3.2 Conformance Limit

Frequency hopping systems operating in the 902.75-927.25MHz band shall use at least 15 channels.

8.3.3 Test Configuration

Test according to clause 7.1 radio frequency test setup 1

8.3.4 Test Procedure

- According to FCC Part15.247(a)(1)(iii)

The EUT must have its hopping function enabled. Use the following spectrum analyzer settings:

Span = the frequency band of operation

RBW \geq 1% of the span(100KHz).

VBW \geq RBW(300KHz).

Sweep = auto

Detector function = peak

Trace = max hold

Allow the trace to stabilize. It may prove necessary to break the span up to sections, in order to clearly show all of the hopping frequencies.

Test Results

Temperature:	24°C	Test Date:	May 20, 2015
Humidity:	53 %	Test By:	King Kong

Hopping Channel Frequency Range	Quantity of Hopping Channel	Quantity of Hopping Channel limit
902.75-927.25	50	> 15

Test Model Number Of Hopping Frequencies
RFID
ASK Modulation

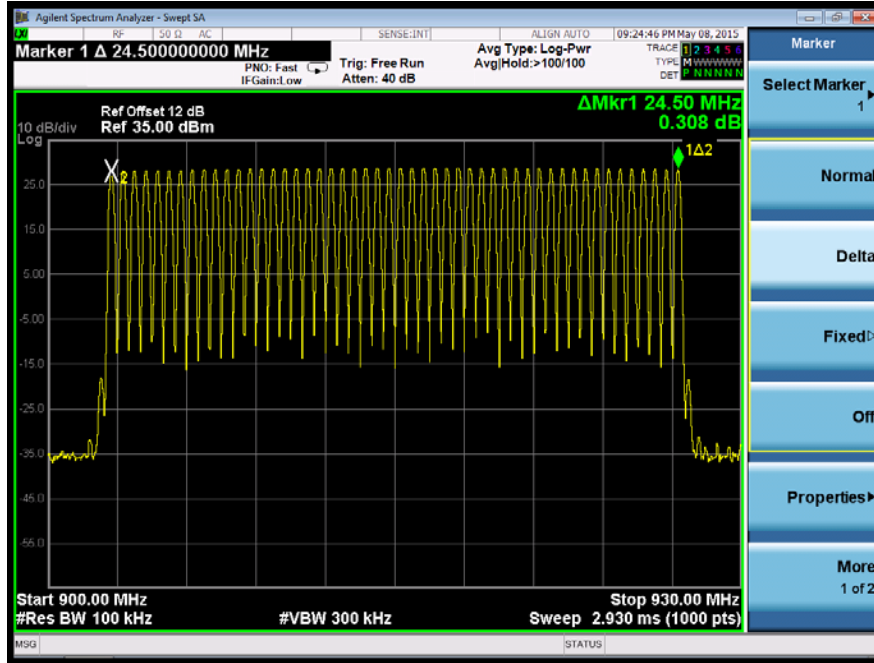

8.4 AVERAGE TIME OF OCCUPANCY (DWELL TIME)

8.4.1 Applicable Standard

According to FCC Part 15.247(a)(1)(iii) and DA 00-705

8.4.2 Conformance Limit

For frequency hopping systems operating in the 902.75-927.25MHz band, the average time of occupancy on any channel shall not be greater than 0.4s within a period of 0.4s multiplied by the number of hopping channels employed.

8.4.3 Test Configuration

Test according to clause 7.1 radio frequency test setup 1

8.4.4 Test Procedure

- According to FCC Part15.247(a)(1)(iii)

The EUT must have its hopping function enabled. Use the following spectrum analyzer settings:

Span = zero span, centered on a hopping channel

RBW = 1 MHz

VBW \geq RBW

Sweep = as necessary to capture the entire dwell time per hopping channel

Detector function = peak

Trace = max hold

If possible, use the marker-delta function to determine the dwell time. If this value varies with different modes of operation (e.g., data rate, modulation format, etc.), repeat this test for each variation. The limit is specified in one of the subparagraphs of this Section.

8.4.5 Test Results

Temperature:	24 °C	Test Date:	May 20, 2015
Humidity:	53 %	Test By:	King Kong

Modulation Mode	Channel Number	occupied time for each channel	dwell time (ms)	Limit(ms)	Verdict
ASK	0	206.20ms	274.933ms	<400	PASS

Note:

The number of occupied channels per second

$4/60=0.067(\text{number}/\text{sec})$

The total number of occupied channels per second

$50*4/60=3.333(\text{number}/\text{sec})$

occupied time for each channel

206.20ms

Dwell time per second

$50*4/60*206.20=687.333\text{ms}$

Dwell time for 0.4second

$50*4/60*206.20*0.4=274.933\text{ms}$

Test Model Average Time Of Occupancy (Dwell Time)
 RFID
 CH 0: 902.75MHz The number of occupied channels per minute

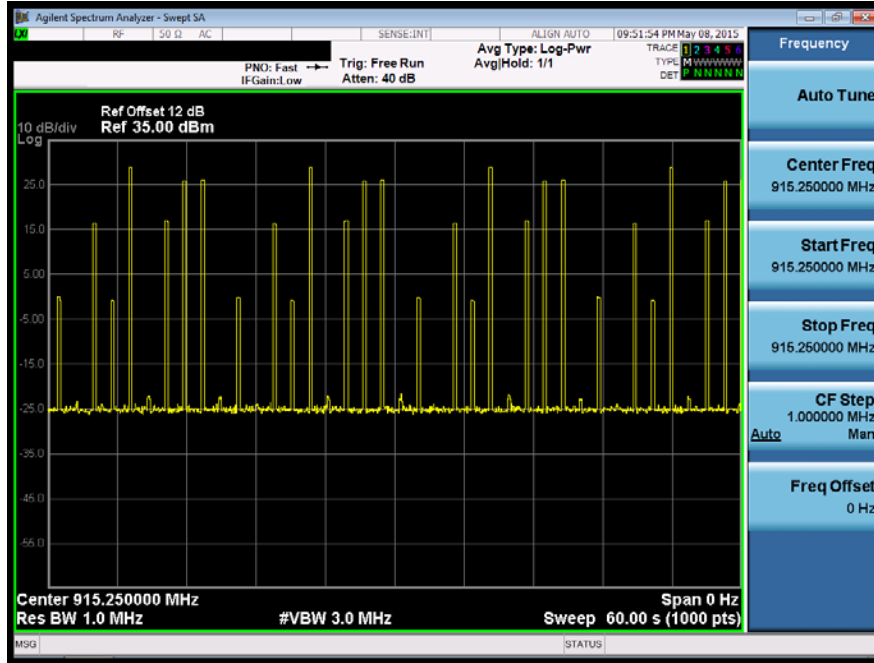

Test Model Average Time Of Occupancy (Dwell Time)
 RFID
 CH 0: 902.75MHz occupied time for each channel

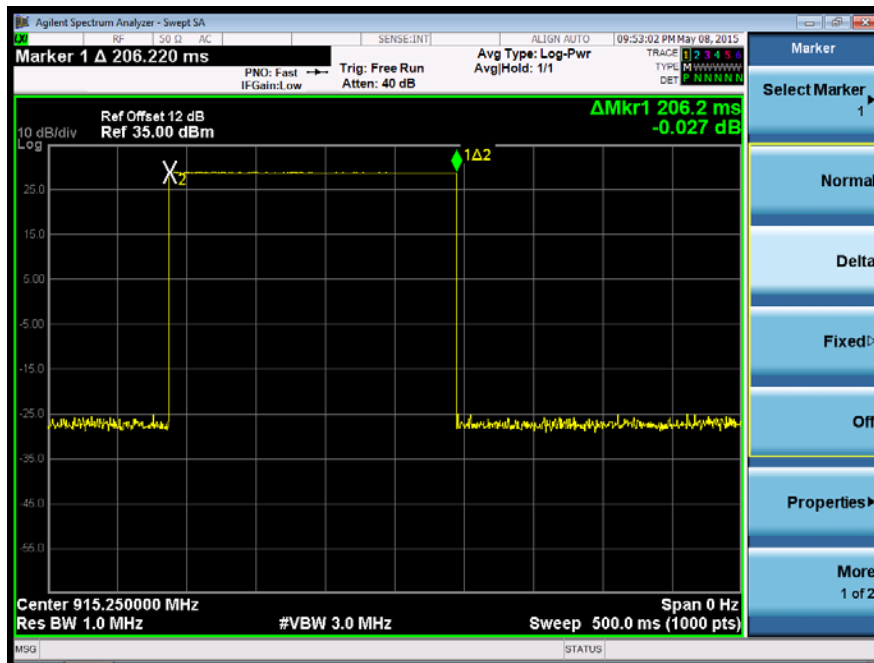

8.5 MAXIMUM PEAK CONDUCTED OUTPUT POWER

8.5.1 Applicable Standard

According to FCC Part 15.247(b)(1) and DA 00-705

8.5.2 Conformance Limit

The max For frequency hopping systems operating in the 902.75-927.25MHz band employing at least 50 non-overlapping hopping channels: 1 watt. For frequency hopping systems operating in the 902.75-927.25 MHz band employing at least 25 non-overlapping hopping channels: 0.25 watt

8.5.3 Test Configuration

Test according to clause 7.1 radio frequency test setup 1

8.5.4 Test Procedure

- According to FCC Part15.247(b)(1)

As an alternative to a peak power measurement, compliance with the limit can be based on a measurement of the maximum conducted output power.

Use the following spectrum analyzer settings:

Set Span = approximately 5 times the 20 dB bandwidth, centered on a hopping channel (about 10MHz)

Set RBW > the 20 dB bandwidth of the emission being measured (about 1MHz)

Set VBW ≥ RBW

Set Sweep = auto

Set Detector function = peak

Set Trace = max hold

Allow the trace to stabilize. Use the marker-to-peak function to set the marker to the peak of the emission to determine the peak amplitude level.

Test Results

Temperature:	24 °C	Test Date:	May 20, 2015
Humidity:	53 %	Test By:	King Kong

Operation Mode	Channel Number	Channel Frequency (MHz)	Measurement Level (dBm)	Limit (dBm)	Verdict
ASK	0	902.75	26.160	27	PASS
	25	915.25	26.633	27	PASS
	49	927.25	26.390	27	PASS
Note: N/A					

Test Model

Maximum Peak Conducted Output Power
 RFID
 Channel 0: 902.75MHz ASK

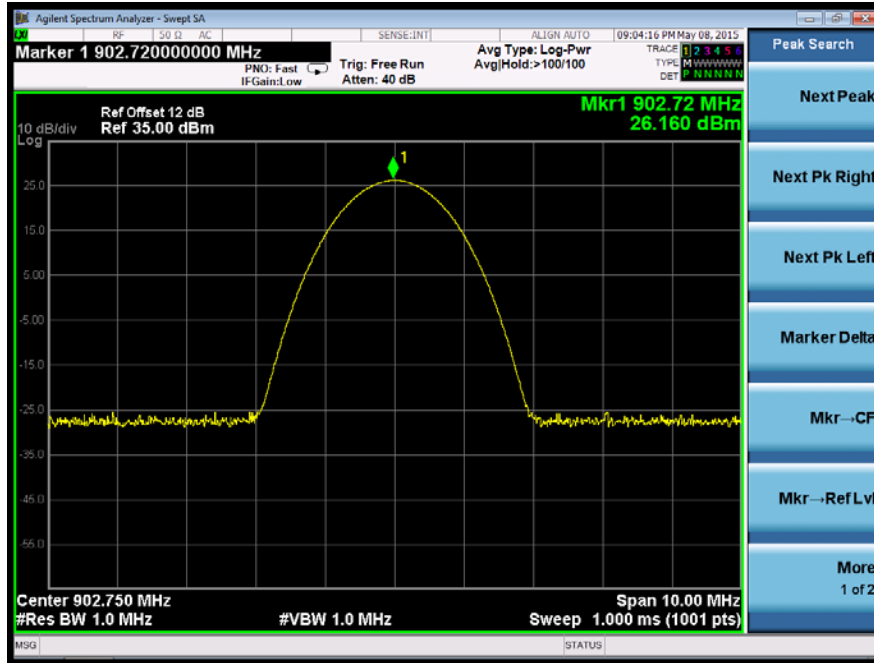

Test Model

Maximum Peak Conducted Output Power
 RFID
 Channel 25: 915.25MHz ASK

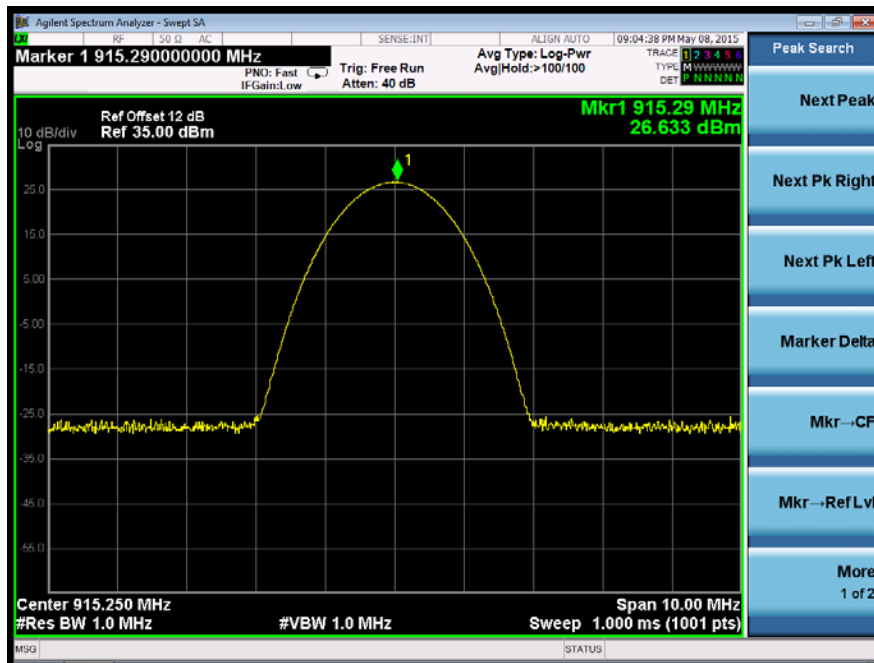

Test Model Maximum Peak Conducted Output Power
RFID
Channel 49: 927.25MHz ASK

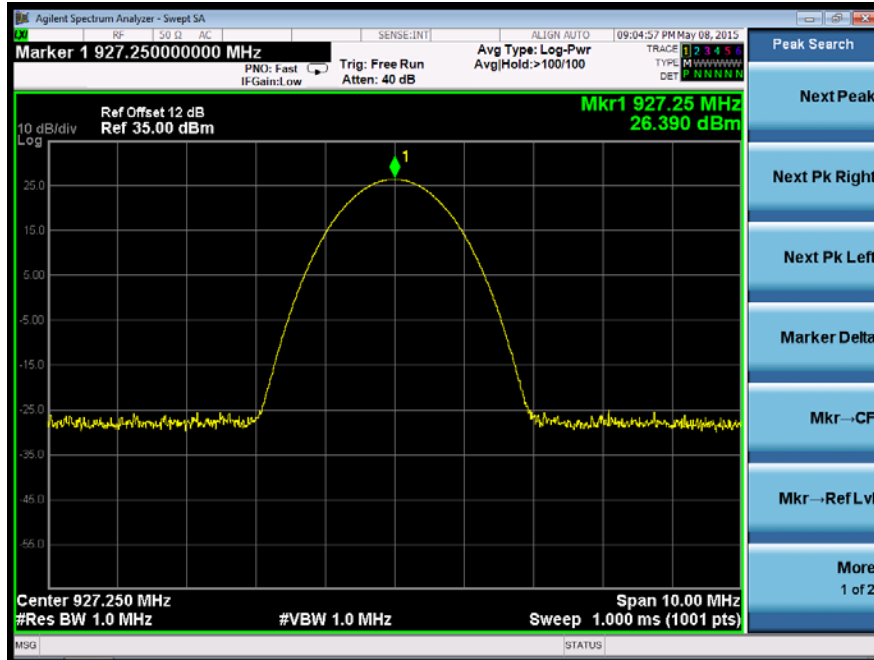

8.6 CONDUCTED SUPRIIOUS EMISSION

8.6.1 Applicable Standard

According to FCC Part 15.247(d) and DA 00-705

8.6.2 Conformance Limit

According to FCC Part 15.247(d):

In any 100 kHz bandwidth outside the frequency band in which the spread spectrum intentional radiator is operating, the radio frequency power that is produced by the intentional radiator shall be at least 20 dB below that in the 100 kHz bandwidth within the band that contains the highest level of the desired power, based on either an RF conducted, provided the transmitter demonstrates compliance with the peak conducted power limits.

8.6.3 Test Configuration

Test according to clause 7.1 radio frequency test setup 1

8.6.4 Test Procedure

The transmitter output (antenna port) was connected to the spectrum analyzer

■ Reference level measurement

Establish a reference level by using the following procedure:

Set instrument center frequency to DSS channel center frequency.

Set Span = approximately 5 times the 20 dB bandwidth, centered on a hopping channel.

Set the RBW = 100 kHz. Set the VBW $\geq 3 \times$ RBW.

Set Detector = peak. Set Sweep time = auto couple.

Set Trace mode = max hold. Allow trace to fully stabilize.

Use the peak marker function to determine the maximum Maximum conduceted level.

Note that the channel found to contain the maximum conduceted level can be used to establish the reference level.

■ Band-edge Compliance of RF Conducted Emissions

Use the following spectrum analyzer settings:

Span = wide enough to capture the peak level of the emission operating on the channel closest to the band-edge, as well as any modulation products which fall outside of the authorized band of operation

Set RBW $\geq 1\%$ of the span=100kHz Set VBW \geq RBW

Set Sweep = auto Set Detector function = peak Set Trace = max hold

Allow the trace to stabilize. Set the marker on the emission at the bandedge, or on the highest modulation product outside of the band, if this level is greater than that at the bandedge. Enable the marker-delta

function, then use the marker-to-peak function to move the marker to the peak of the in-band emission.

The marker-delta value now displayed must comply with the limit specified in this Section.

Now, using the same instrument settings, enable the hopping function of the EUT. Allow the trace to stabilize. Follow the same procedure listed above to determine if any spurious emissions caused by the hopping function also comply with the specified limit.

■ Conduceted Spurious RF Conducted Emission

Use the following spectrum analyzer settings:

Span = wide enough to capture the peak level of the in-band emission and all spurious emissions (e.g., harmonics) from the lowest frequency generated in the EUT up through the 10th harmonic.(30MHz to 25GHz). Set RBW = 100 kHz Set VBW \geq RBW

Set Sweep = auto Set Detector function = peak Set Trace = max hold

Allow the trace to stabilize. Set the marker on the peak of any spurious emission recorded. The level

displayed must comply with the limit specified in this Section.

8.6.5 Test Results

Test Model Maximum Conducted Level RBW=100kHz
 RFID
 Channel 0: 902.75MHz ASK

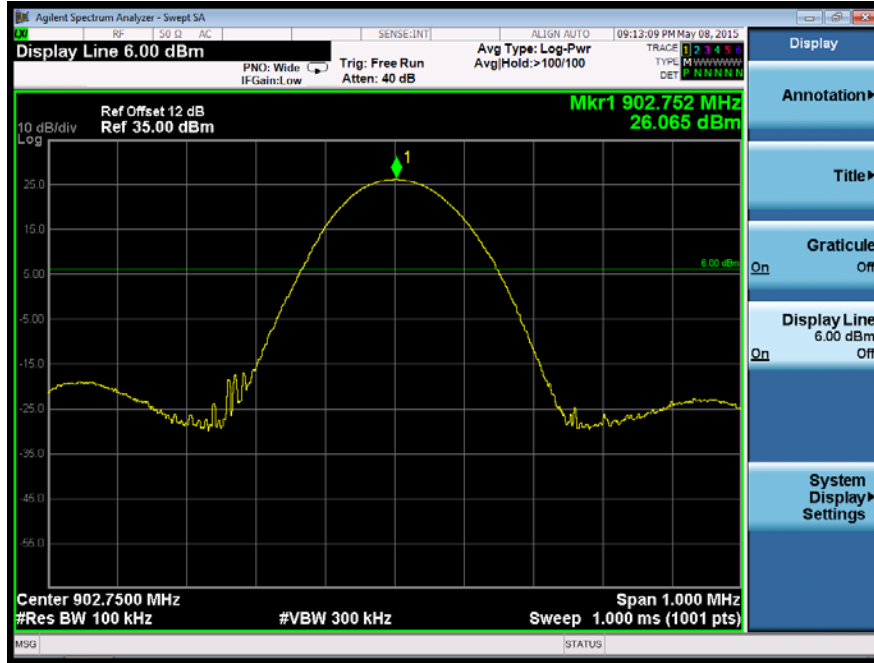

Test Model Conducted Spurious RF Conducted Emission
 RFID
 Channel 0: 902.75MHz ASK



Test Model Band-edge Conducted Emissions
RFID
Channel 0: 902.75MHz ASK

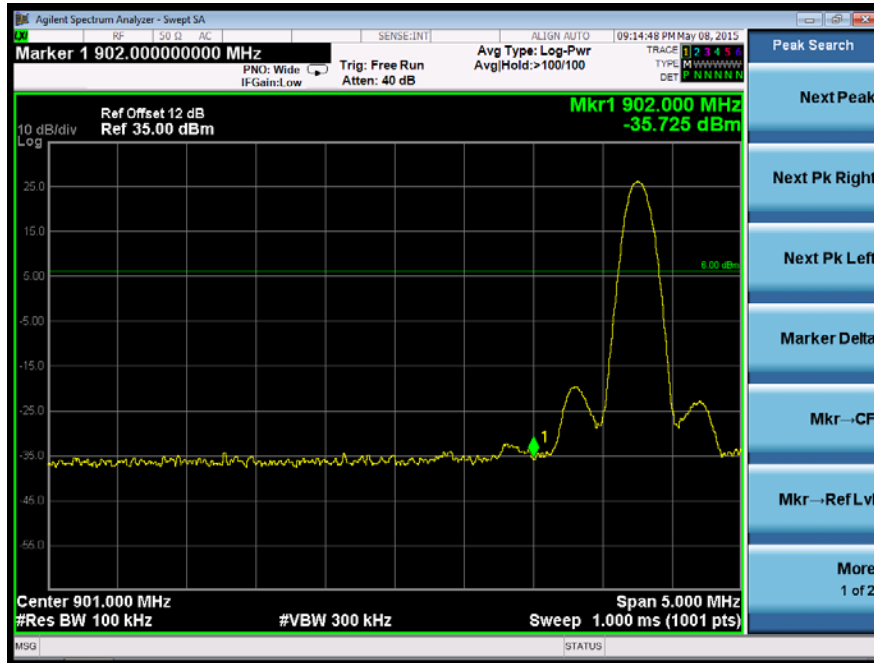

Test Model Maximum Conduceted Level RBW=100kHz
 RFID
 Channel 49: 927.25MHz ASK

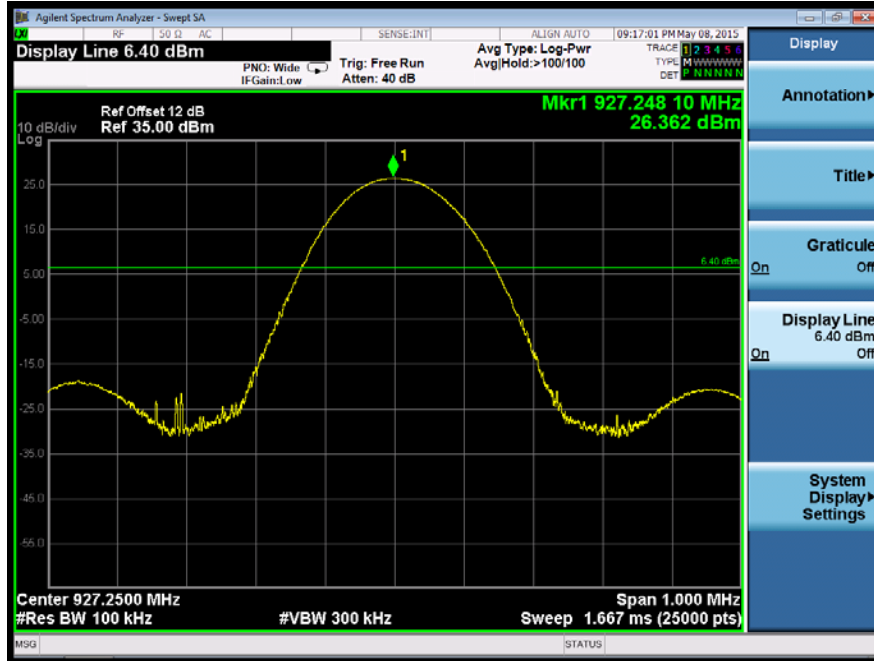

Test Model Conduceted Spurious RF Conducted Emission
 RFID
 Channel 49: 927.25MHz ASK

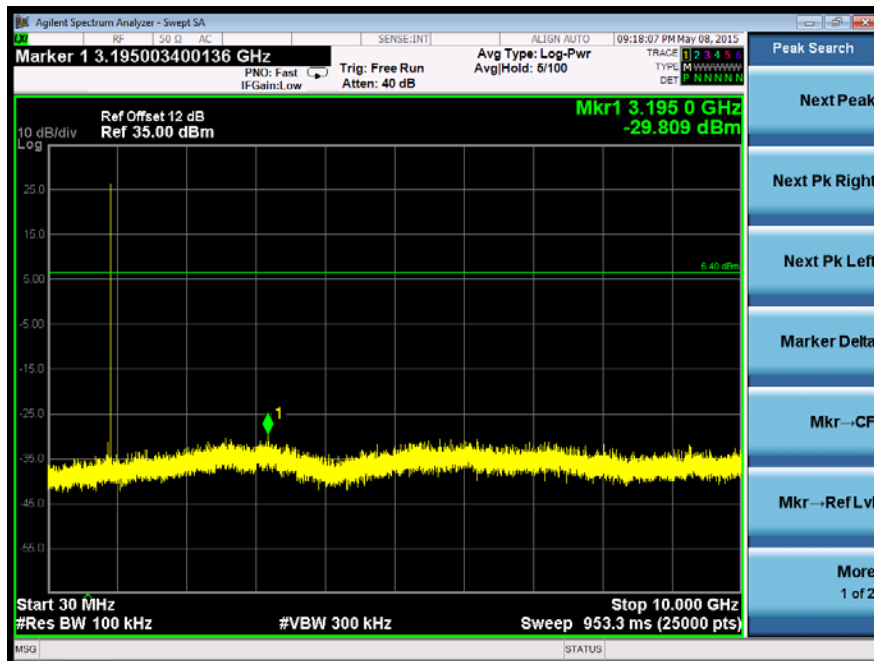

Test Model

Band-edge Conducted Emissions
RFID
Channel 49: 927.25MHz

ASK

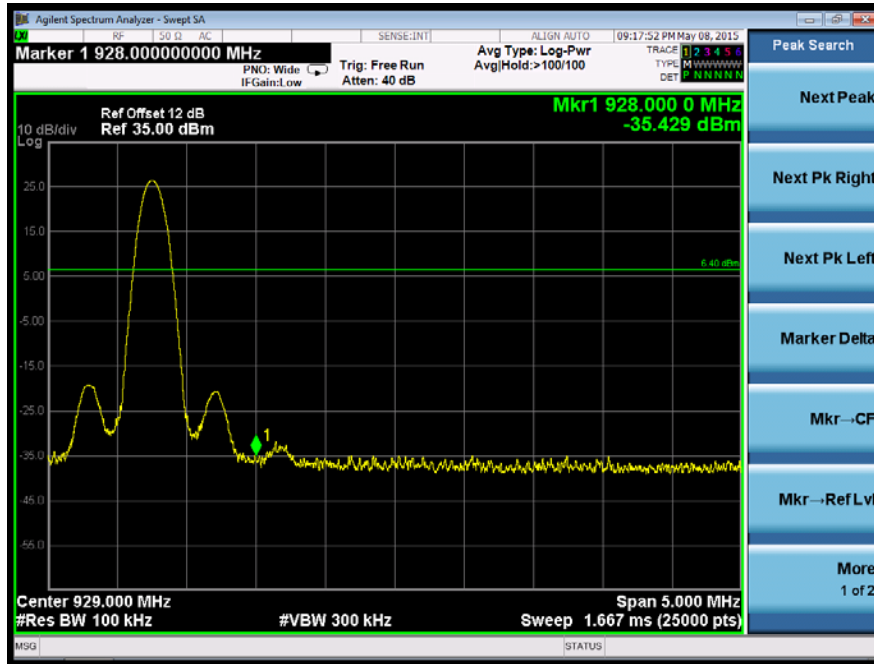

Test Model

Maximum Conduced Level RBW=100kHz
 RFID
 Hopping ASK



Test Model

Conduced Spurious RF Conducted Emission
 RFID
 Hopping ASK

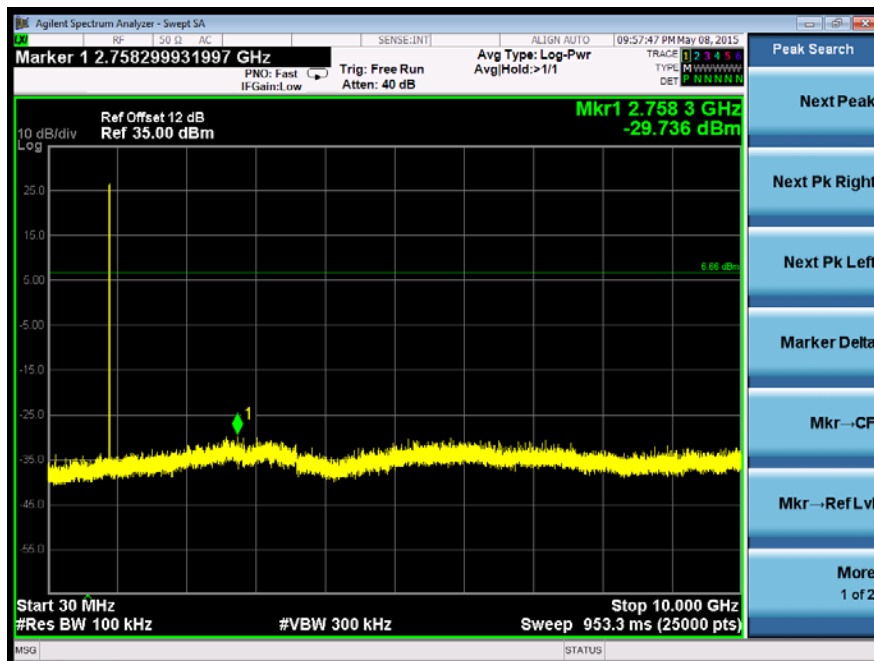

Test Model Band-edge Conducted Emissions
 RFID
 Hopping ASK

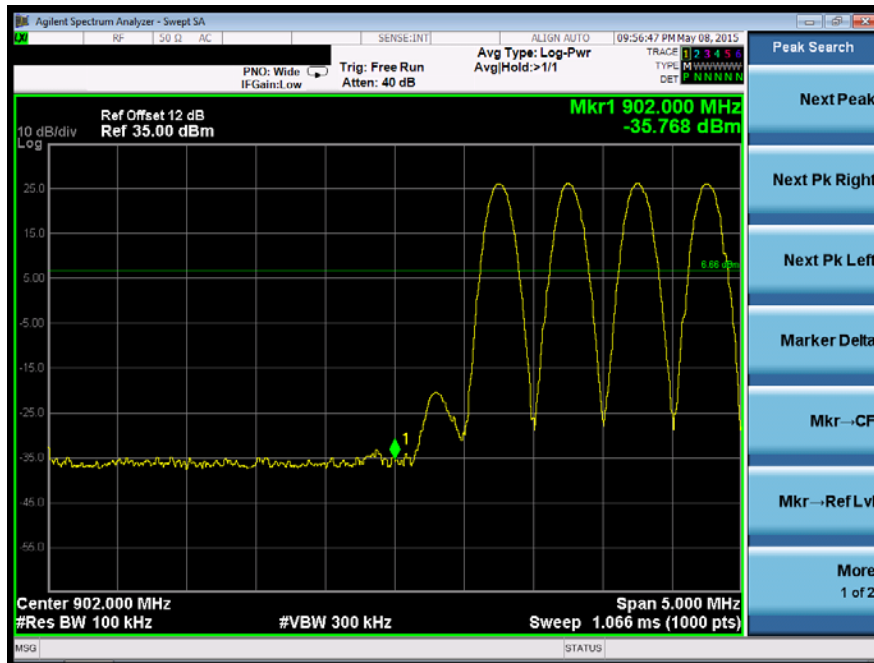

Test Model Band-edge Conducted Emissions
 RFID
 Hopping ASK

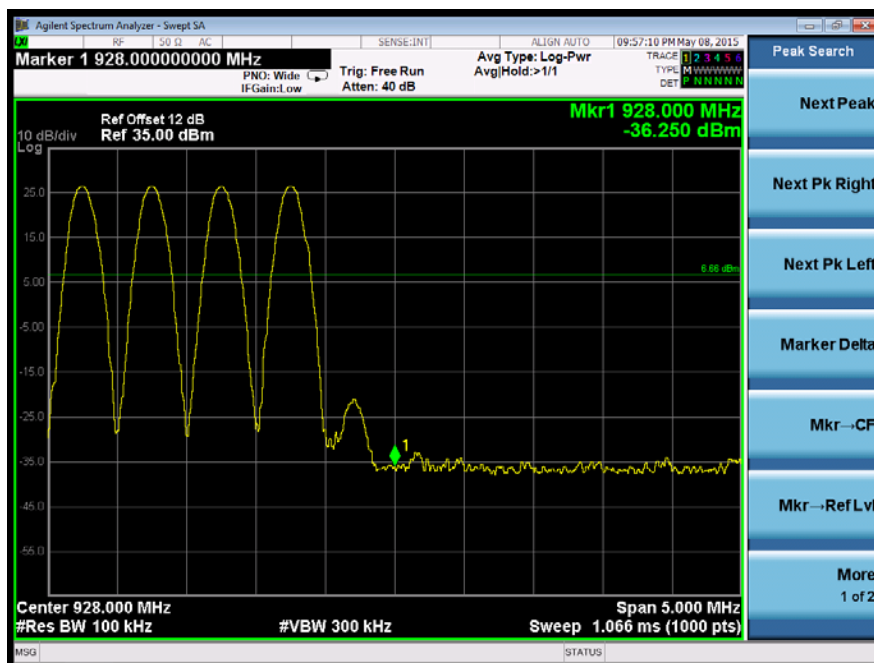

8.7 RADIATED SPURIOUS EMISSION

8.7.1 Applicable Standard

According to FCC Part 15.247(d) and 15.209 and DA 00-705

8.7.2 Conformance Limit

According to FCC Part 15.247(d): radiated emissions which fall in the restricted bands, as defined in §15.205(a), must also comply with the radiated emission limits specified in §15.209(a) (see §15.205(c)).
 According to FCC Part15.205, Restricted bands

MHz	MHz	MHz	GHz
0.090-0.110	16.42-16.423	399.9-410	4.5-5.15
10.495-0.505	16.69475-16.69525	608-614	5.35-5.46
2.1735-2.1905	16.80425-16.80475	960-1240	7.25-7.75
4.125-4.128	25.5-25.67	1300-1427	8.025-8.5
4.17725-4.17775	37.5-38.25	1435-1626.5	9.0-9.2
4.20725-4.20775	73-74.6	1645.5-1646.5	9.3-9.5
6.215-6.218	74.8-75.2	1660-1710	10.6-12.7
6.26775-6.26825	123-138	2200-2300	14.47-14.5
8.291-8.294	149.9-150.05	2310-2390	15.35-16.2
8.362-8.366	156.52475-156.52525	2483.5-2500	17.7-21.4
8.37625-8.38675	156.7-156.9	2690-2900	22.01-23.12
8.41425-8.41475	162.0125-167.17	3260-3267	23.6-24.0
12.29-12.293	167.72-173.2	3332-3339	31.2-31.8
12.51975-12.52025	240-285	3345.8-3358	36.43-36.5
12.57675-12.57725	322-335.4	3600-4400	(2)
13.36-13.41			

According to FCC Part15.205, the level of any transmitter spurious emission in Restricted bands shall not exceed the level of the emission specified in the following table

Restricted Frequency(MHz)	Field Strength (µV/m)	Field Strength (dBµV/m)	Measurement Distance
0.009-0.490	2400/F(KHz)	20 log (uV/m)	300
0.490-1.705	24000/F(KHz)	20 log (uV/m)	30
1.705-30	30	29.5	30
30-88	100	40	3
88-216	150	43.5	3
216-960	200	46	3
Above 960	500	54	3

8.7.3 Test Configuration

Test according to clause 7.2 radio frequency test setup 2

8.7.4 Test Procedure

This test is required for any spurious emission that falls in a Restricted Band, as defined in Section 15.205. It must be performed with the highest gain of each type of antenna proposed for use with the EUT. Use the following spectrum analyzer settings:

The EUT was placed on a turn table which is 0.8m above ground plane.

Maximum procedure was performed on the highest emissions to ensure EUT compliance.

Span = wide enough to fully capture the emission being measured

RBW = 1 MHz for $f \geq 1$ GHz(1GHz to 25GHz), 100 kHz for $f < 1$ GHz(30MHz to 1GHz), 200Hz for $f < 150$ KHz(9KHz to 150KHz), 9KHz for $f < 30$ MHz(150KHz to 30MHz)

VBW \geq RBW

Sweep = auto

Detector function = peak

Trace = max hold

Follow the guidelines in ANSI C63.10-2013 with respect to maximizing the emission by rotating the EUT, measuring the emission while the EUT is situated in three orthogonal planes (if appropriate), adjusting the measurement antenna height and polarization, etc. A pre-amp and a high pass filter are required for this test, in order to provide the measuring system with sufficient sensitivity. Allow the trace to stabilize. The peak reading of the emission, after being corrected by the antenna factor, cable loss, pre-amp gain, etc., is the peak field strength, which must comply with the limit specified in Section 15.35(b). Submit this data. Now set the VBW to 10 Hz, while maintaining all of the other instrument settings. This peak level, once corrected, must comply with the limit specified in Section 15.209. If the dwell time per channel of the hopping signal is less than 100 ms, then the reading obtained with the 10 Hz VBW may be further adjusted by a "duty cycle correction factor", derived from $20\log(\text{dwell time}/100 \text{ ms})$, in an effort to demonstrate compliance with the 15.209 limit. Submit this data.

Repeat above procedures until all frequency measured was complete.

8.7.5 Test Results

■ Spurious Emission below 30MHz (9KHz to 30MHz)

Temperature:	24°C	Test Date:	May 20, 2015
Humidity:	53 %	Test By:	KK
Test mode:	TX Mode		

Freq. (MHz)	Ant.Pol. H/V	Emission Level(dBuV/m)		Limit 3m(dBuV/m)		Over(dB)	
		PK	AV	PK	AV	PK	AV
--	--	--	--	--	--	--	--

Note: the amplitude of spurious emission that is attenuated by more than 20dB below the permissible limit has no need to be reported.

Distance extrapolation factor = $40\log(\text{Specific distance}/ \text{test distance})$ (dB);

Limit line=Specific limits(dBuV) + distance extrapolation factor

■ Spurious Emission Above 1GHz (1GHz to 10GHz)

Temperature:	24°C	Test Date:	May 20, 2015
Humidity:	53 %	Test By:	King Kong
Test mode:	ASK	Frequency:	Channel 0: 902.75MHz

Freq. (MHz)	Ant.Pol. H/V	Emission Level(dBuV/m)		Limit 3m(dBuV/m)		Over(dB)	
		PK	AV	PK	AV	PK	AV
1243.00	V	52.14	49.40	74.00	54.00	-21.86	-4.60
1720.00	V	47.35	48.05	74.00	54.00	-26.65	-5.95
2708.25	V	48.52	48.44	74.00	54.00	-25.48	-5.56
--	--	--	--	--	--	--	--
--	--	--	--	--	--	--	--
--	--	--	--	--	--	--	--
1243.00	H	52.25	48.76	74.00	54.00	-21.75	-5.24
1828.00	H	48.44	49.00	74.00	54.00	-25.56	-5.00
2708.25	H	50.50	48.68	74.00	54.00	-23.50	-5.32

Temperature: 24℃	Test Date: May 20, 2015
Humidity: 53 %	Test By: King Kong
Test mode: ASK	Frequency: Channel 25: 915.25MHz

Freq. (MHz)	Ant.Pol. H/V	Emission Level(dBuV/m)		Limit 3m(dBuV/m)		Over(dB)	
		PK	AV	PK	AV	PK	AV
1243.00	V	52.77	49.80	74.00	54.00	-21.23	-4.20
1720.00	V	48.20	48.20	74.00	54.00	-25.80	-5.80
2745.75	V	48.69	48.69	74.00	54.00	-25.31	-5.31
--	--	--	--	--	--	--	--
--	--	--	--	--	--	--	--
--	--	--	--	--	--	--	--
1243.00	H	52.94	48.90	74.00	54.00	-21.06	-5.10
1828.00	H	49.42	49.42	74.00	54.00	-24.58	-4.58
2745.75	H	50.86	49.50	74.00	54.00	-23.14	-4.50

Temperature: 24℃	Test Date: May 20, 2015
Humidity: 53 %	Test By: King Kong
Test mode: ASK	Frequency: Channel 49: 927.25MHz

Freq. (MHz)	Ant.Pol. H/V	Emission Level(dBuV/m)		Limit 3m(dBuV/m)		Over(dB)	
		PK	AV	PK	AV	PK	AV
1243.00	V	52.29	49.06	74.00	54.00	-21.71	-4.94
1720.00	V	47.36	47.89	74.00	54.00	-26.64	-6.11
2781.75	V	48.54	48.06	74.00	54.00	-25.46	-5.94
--	--	--	--	--	--	--	--
--	--	--	--	--	--	--	--
--	--	--	--	--	--	--	--
1243.00	H	52.42	47.95	74.00	54.00	-21.58	-6.05
1828.00	H	49.06	49.28	74.00	54.00	-24.94	-4.72
2781.75	H	50.12	48.79	74.00	54.00	-23.88	-5.21

- Note:**
- (1) All Readings are Peak Value (VBW=3MHz) and Peak Value (VBW=10Hz).
 - (2) Emission Level= Reading Level+Probe Factor +Cable Loss.
 - (3) Data of measurement within this frequency range shown "--" in the table above means the reading of emissions are attenuated more than 20dB below the permissible limits or the field strength is too small to be measured.

■ Spurious Emission below 1GHz (30MHz to 1GHz)

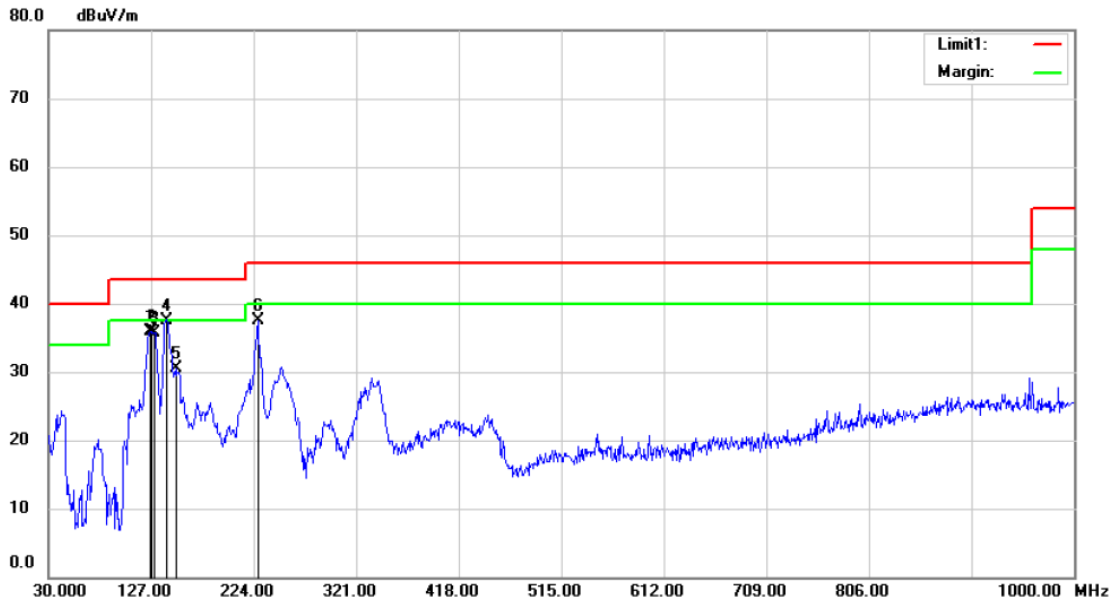

Site site #1 Polarization: *Horizontal* Temperature: 24 C
 Limit: (RE)FCC PART 15 CLASS B Power: AC 120V/60Hz Humidity: 53 %
 EUT: UHF RFID Reader Module
 M/N: HYM360
 Mode:902.75
 Note:

No.	Mk.	Freq.	Reading Level	Correct Factor	Measurement	Limit	Over	Antenna Height	Table Degree	
		MHz	dBuV	dB	dBuV/m	dBuV/m	dB	cm	degree	Comment
1		126.0300	52.77	-16.89	35.88	43.50	-7.62	QP		
2		127.9700	52.90	-17.07	35.83	43.50	-7.67	QP		
3		129.9100	53.02	-17.25	35.77	43.50	-7.73	QP		
4	*	141.5500	55.44	-17.84	37.60	43.50	-5.90	QP		
5		150.2800	48.66	-18.12	30.54	43.50	-12.96	QP		
6		227.8800	52.83	-15.37	37.46	46.00	-8.54	QP		

*:Maximum data x:Over limit !:over margin

Operator: KK

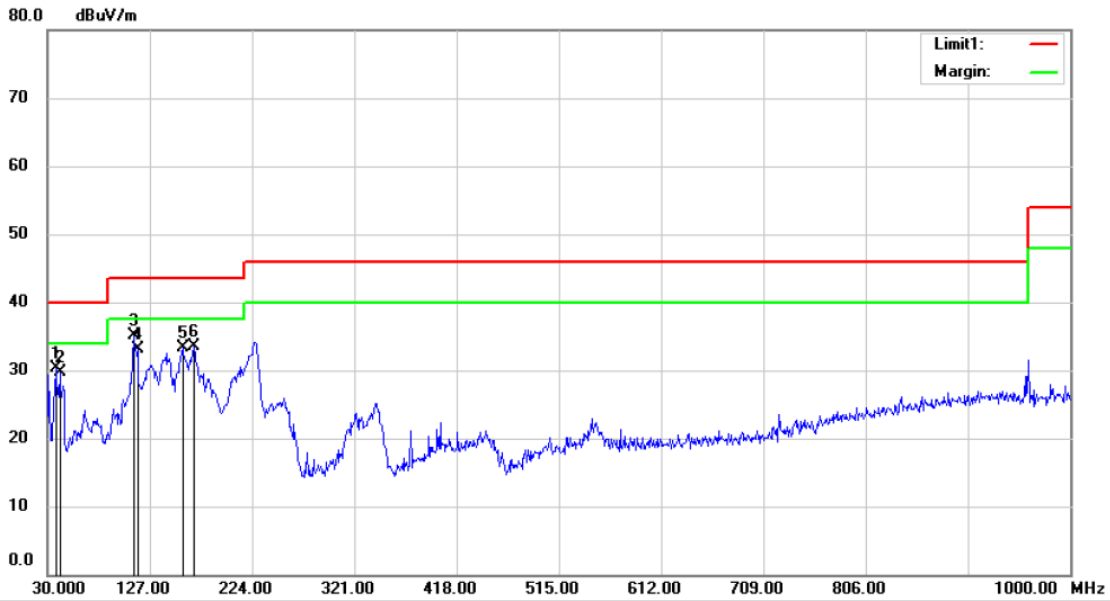

Site site #1 Polarization: *Vertical* Temperature: 24 C
 Limit: (RE)FCC PART 15 CLASS B Power: AC 120V/60Hz Humidity: 53 %
 EUT: UHF RFID Reader Module
 M/N: HYM360
 Mode:902.75
 Note:

No.	Mk.	Freq.	Reading Level	Correct Factor	Measurement	Limit	Over	Antenna Height	Table Degree	
		MHz	dBuV	dB	dBuV/m	dBuV/m	dB	cm	degree	Comment
1		37.7600	44.57	-14.33	30.24	40.00	-9.76			QP
2		41.6400	42.70	-12.93	29.77	40.00	-10.23			QP
3	*	111.4800	49.55	-14.54	35.01	43.50	-8.49			QP
4		115.3600	48.38	-15.36	33.02	43.50	-10.48			QP
5		158.0400	51.95	-18.59	33.36	43.50	-10.14			QP
6		168.7100	52.77	-19.34	33.43	43.50	-10.07			QP

*:Maximum data x:Over limit !:over margin

Operator: KK

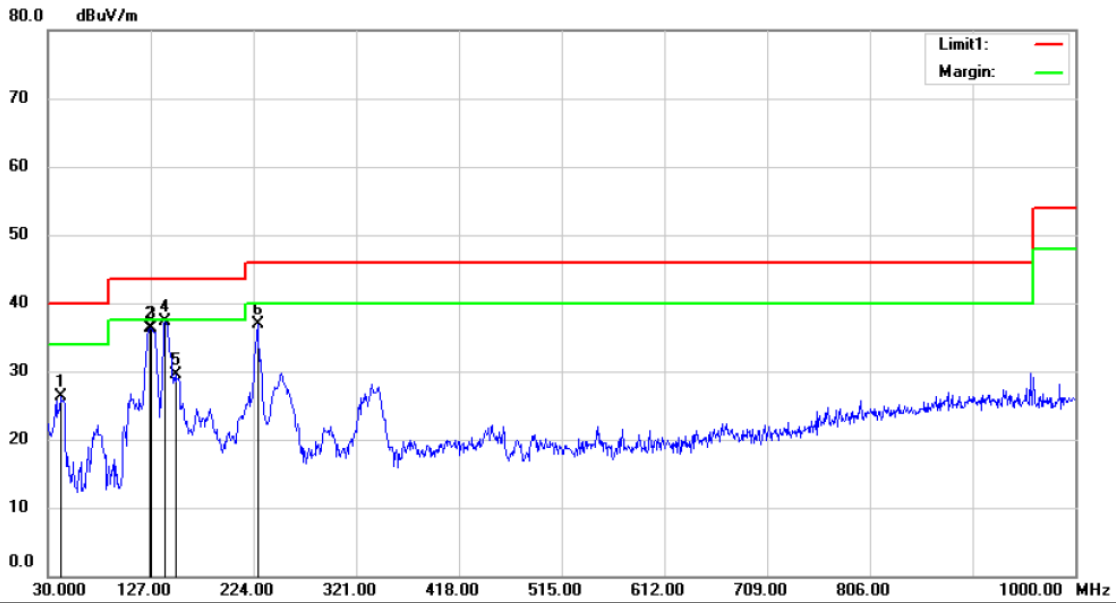

Site site #1 Polarization: **Horizontal** Temperature: 24 C
 Limit: (RE)FCC PART 15 CLASS B Power: AC 120V/60Hz Humidity: 53 %
 EUT: UHF RFID Reader Module
 M/N: HYM360
 Mode:915.25
 Note:

No.	Mk.	Freq.	Reading Level	Correct Factor	Measurement	Limit	Over	Antenna Height	Table Degree	
		MHz	dBuV	dB	dBuV/m	dBuV/m	dB	cm	degree	Comment
1		41.6400	39.16	-12.93	26.23	40.00	-13.77	QP		
2		126.0300	53.27	-16.89	36.38	43.50	-7.12	QP		
3		127.9700	53.40	-17.07	36.33	43.50	-7.17	QP		
4	*	140.5800	55.20	-17.80	37.40	43.50	-6.10	QP		
5		150.2800	47.66	-18.12	29.54	43.50	-13.96	QP		
6		227.8800	52.33	-15.37	36.96	46.00	-9.04	QP		

*:Maximum data x:Over limit !:over margin

Operator: KK

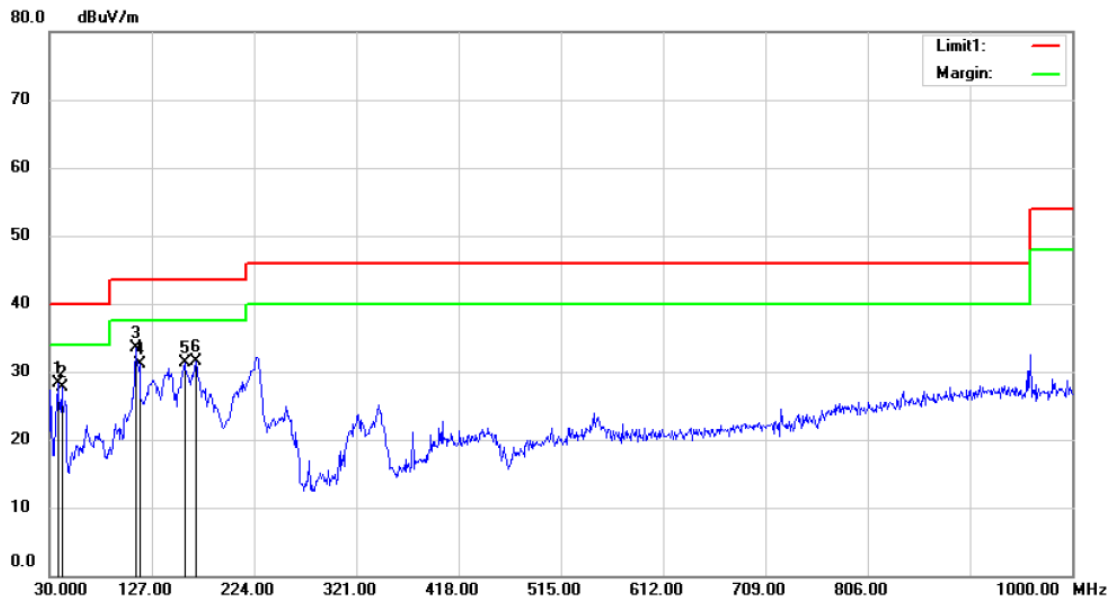

Site site #1 Polarization: **Vertical** Temperature: 24 C
 Limit: (RE)FCC PART 15 CLASS B Power: AC 120V/60Hz Humidity: 53 %
 EUT: UHF RFID Reader Module
 M/N: HYM360
 Mode:915.25
 Note:

No.	Mk.	Freq.	Reading Level	Correct Factor	Measure-ment	Limit	Over	Antenna Height	Table Degree	
		MHz	dBuV	dB	dBuV/m	dBuV/m	dB	cm	degree	Comment
1		37.7600	42.57	-14.33	28.24	40.00	-11.76			QP
2		41.6400	40.70	-12.93	27.77	40.00	-12.23			QP
3	*	111.4800	48.05	-14.54	33.51	43.50	-9.99			QP
4		115.3600	46.38	-15.36	31.02	43.50	-12.48			QP
5		158.0400	49.95	-18.59	31.36	43.50	-12.14			QP
6		168.7100	50.77	-19.34	31.43	43.50	-12.07			QP

*:Maximum data x:Over limit !:over margin

Operator: KK

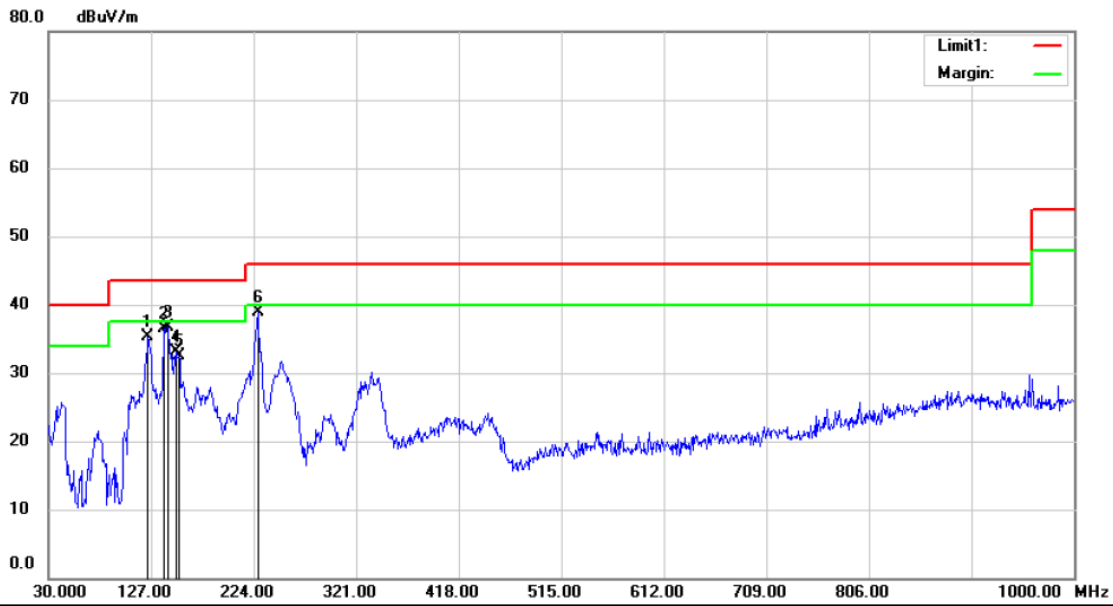

Site site #1 Polarization: **Horizontal** Temperature: 24 C
 Limit: (RE)FCC PART 15 CLASS B Power: AC 120V/60Hz Humidity: 53 %
 EUT: UHF RFID Reader Module
 M/N: HYM360
 Mode:927.25
 Note:

No.	Mk.	Freq.	Reading Level	Correct Factor	Measurement	Limit	Over	Antenna Height	Table Degree	
		MHz	dBuV	dB	dBuV/m	dBuV/m	dB	cm	degree	Comment
1		124.0900	52.02	-16.72	35.30	43.50	-8.20	QP		
2		138.6400	54.14	-17.70	36.44	43.50	-7.06	QP		
3	*	142.5200	54.64	-17.86	36.78	43.50	-6.72	QP		
4		150.2800	51.16	-18.12	33.04	43.50	-10.46	QP		
5		153.1900	50.73	-18.29	32.44	43.50	-11.06	QP		
6		227.8800	54.33	-15.37	38.96	46.00	-7.04	QP		

*:Maximum data x:Over limit !:over margin

Operator: KK

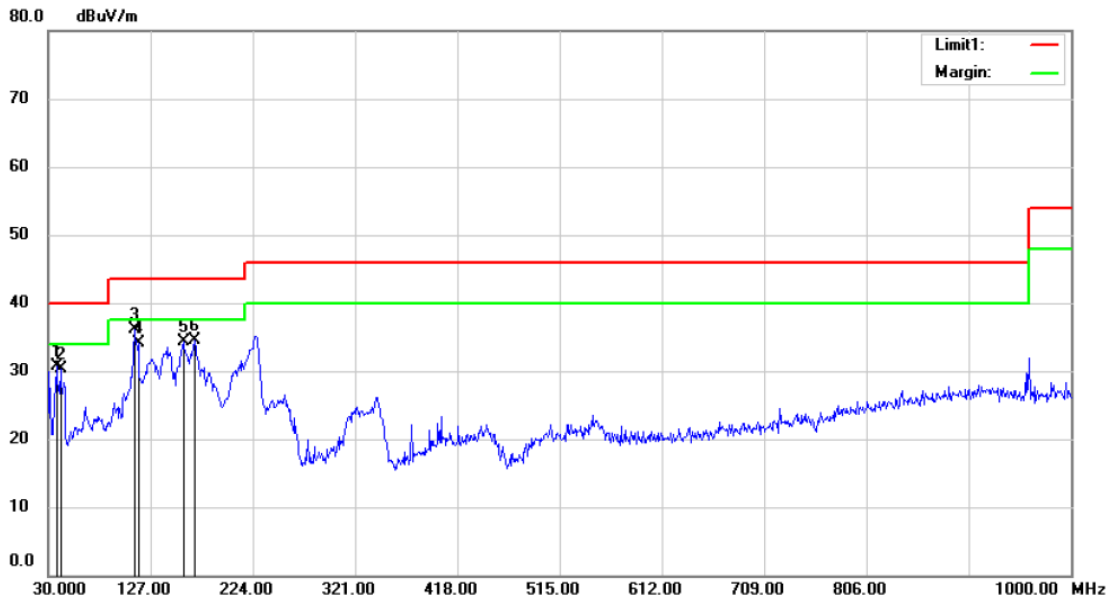

Site site #1 Polarization: *Vertical* Temperature: 24 C
 Limit: (RE)FCC PART 15 CLASS B Power: AC 120V/60Hz Humidity: 53 %
 EUT: UHF RFID Reader Module
 M/N: HYM360
 Mode:927.25
 Note:

No.	Mk.	Freq.	Reading Level	Correct Factor	Measurement	Limit	Over	Antenna Height	Table Degree	
		MHz	dBuV	dB	dBuV/m	dBuV/m	dB	cm	degree	Comment
1		37.7600	45.07	-14.33	30.74	40.00	-9.26			QP
2		41.6400	43.20	-12.93	30.27	40.00	-9.73			QP
3	*	111.4800	50.55	-14.54	36.01	43.50	-7.49			QP
4		115.3600	49.38	-15.36	34.02	43.50	-9.48			QP
5		158.0400	52.95	-18.59	34.36	43.50	-9.14			QP
6		168.7100	53.77	-19.34	34.43	43.50	-9.07			QP

*:Maximum data x:Over limit !:over margin

Operator: KK

8.8 CONDUCTED EMISSION TEST

8.8.1 Applicable Standard

According to FCC Part 15.207(a)

8.8.2 Conformance Limit

Frequency(MHz)	Conducted Emission Limit	
	Quasi-peak	Average
0.15-0.5	66-56	56-46
0.5-5.0	56	46
5.0-30.0	60	50

Note: 1. The lower limit shall apply at the transition frequencies
2. The limit decreases in line with the logarithm of the frequency in the range of 0.15 to 0.50MHz.

8.8.3 Test Configuration

Test according to clause 7.3 conducted emission test setup

8.8.4 Test Procedure

The EUT was placed on a table which is 0.8m above ground plane.
Maximum procedure was performed on the highest emissions to ensure EUT compliance.
Repeat above procedures until all frequency measured were complete.

8.8.5 Test Results

Pass

Test Result:	Pass	Probe:	L1
Standard:	(CE)FCC PART 15 class B_QP	Power Source:	AC 120V/60Hz
Test item:	Conduction Test	Date:	15/05/15/
Temp./Hum.:	26(C)/60%RH	Time:	10/03/39
EUT:	UHF RFID Reader Module	Test Mode:	ON
Model:	HYM360	Tested By:	Wang
Note:			

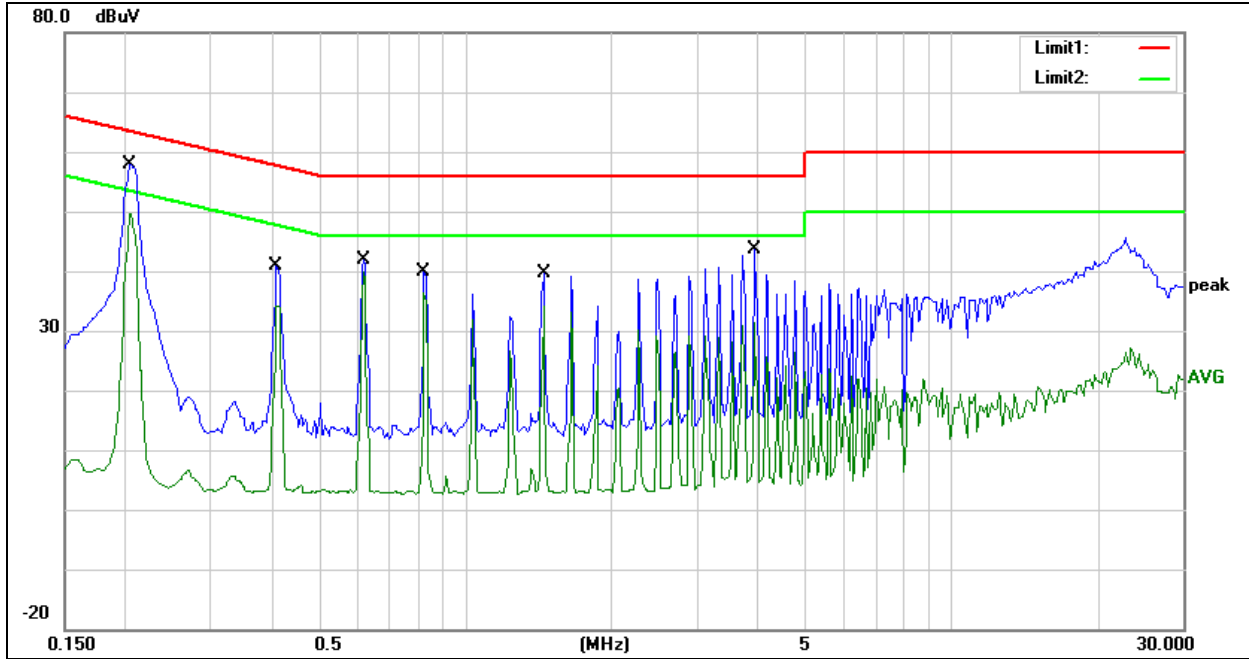

No.	Frequency (MHz)	Reading (dBuV)	Correct Factor(dB)	Result Level (dBuV)	Limit Level (dBuV)	Over Limit (dB)	Remark
1	0.2050	57.81	0.00	57.81	63.41	-5.60	QP
2	0.2050	49.61	0.00	49.61	53.41	-3.80	AVG
3	0.4100	40.81	0.00	40.81	57.65	-16.84	QP
4	0.4100	34.25	0.00	34.25	47.65	-13.40	AVG
5	0.6200	41.96	0.00	41.96	56.00	-14.04	QP
6	0.6200	39.89	0.00	39.89	46.00	-6.11	AVG
7	0.8250	39.86	0.00	39.86	56.00	-16.14	QP
8	0.8250	36.30	0.00	36.30	46.00	-9.70	AVG
9	1.4500	39.54	0.00	39.54	56.00	-16.46	QP
10	1.4500	34.12	0.00	34.12	46.00	-11.88	AVG
11	3.9350	43.69	0.00	43.69	56.00	-12.31	QP
12	3.9350	31.50	0.00	31.50	46.00	-14.50	AVG

Note:Over Limit=Result Level-Limit Level.

Test Result:	Pass	Probe:	N
Standard:	(CE)FCC PART 15 class B_QP	Power Source:	AC 120V/60Hz
Test item:	Conduction Test	Date:	15/05/15/
Temp./Hum.:	26(C)/60%RH	Time:	10/07/14
EUT:	UHF RFID Reader Module	Test Mode:	ON
Model:	HYM360	Tested By:	Wang
Note:			

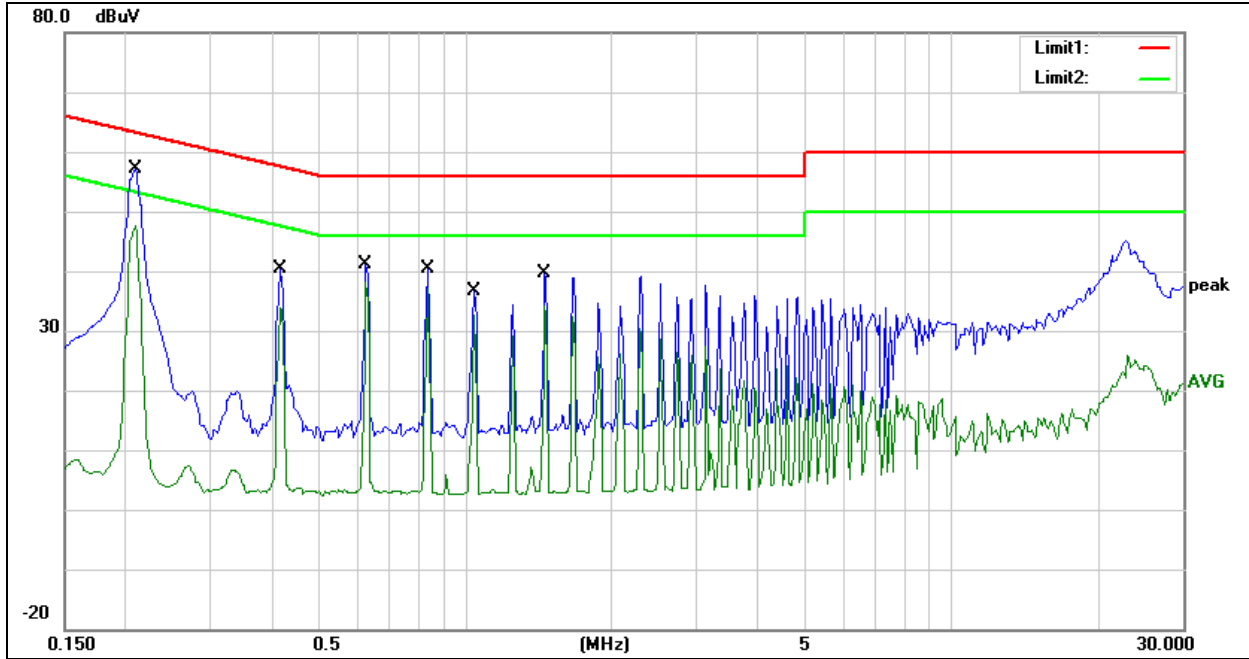

No.	Frequency (MHz)	Reading (dBuV)	Correct Factor(dB)	Result Level (dBuV)	Limit Level (dBuV)	Over Limit (dB)	Remark
1	0.2100	57.22	0.00	57.22	63.21	-5.99	QP
2	0.2100	47.75	0.00	47.75	53.21	-5.46	AVG
3	0.4150	40.47	0.00	40.47	57.55	-17.08	QP
4	0.4150	33.99	0.00	33.99	47.55	-13.56	AVG
5	0.6250	41.18	0.00	41.18	56.00	-14.82	QP
6	0.6250	38.19	0.00	38.19	46.00	-7.81	AVG
7	0.8350	40.34	0.00	40.34	56.00	-15.66	QP
8	0.8350	37.22	0.00	37.22	46.00	-8.78	AVG
9	1.0450	36.61	0.00	36.61	56.00	-19.39	QP
10	1.0450	32.54	0.00	32.54	46.00	-13.46	AVG
11	1.4600	39.56	0.00	39.56	56.00	-16.44	QP
12	1.4600	34.04	0.00	34.04	46.00	-11.96	AVG

Note:Over Limit=Result Level-Limit Level.

8.9 ANTENNA APPLICATION

8.9.1 Antenna Requirement

Standard	Requirement
FCC CRF Part 15.203	An intentional radiator shall be designed to ensure that no antenna other than that furnished by the responsible party shall be used with the device. The use of a permanently attached antenna or of an antenna that uses a unique coupling to the intentional radiator shall be considered sufficient to comply with the provisions of this section. The manufacturer may design the unit so that a broken antenna can be replaced by the user, but the use of a standard antenna jack or electrical connector is prohibited. This requirement does not apply to carrier current devices or to devices operated under the provisions of §15.211, §15.213, §15.217, §15.219, or §15.221. Further, this requirement does not apply to intentional radiators that must be professionally installed, such as perimeter protection systems and some field disturbance sensors, or to other intentional radiators which, in accordance with §15.31(d), must be measured at the installation site. However, the installer shall be responsible for ensuring that the proper antenna is employed so that the limits in this part are not exceeded.

For intentional device, according to FCC 47 CFR Section 15.203, an intentional radiator shall be designed to ensure that no antenna other than that furnished by the responsible party shall be used with the device. And according to FCC 47 CFR Section 15.247 (b), if transmitting antennas of directional gain greater than 6dBi are used, the power shall be reduced by the amount in dB that the directional gain of the antenna exceeds 6dBi.

8.9.2 Result

PASS.

The EUT has 1 antenna: a External Antenna, the gain is 9.0 dBi;

- Note:
- Antenna use a permanently attached antenna which is not replaceable.
 - Not using a standard antenna jack or electrical connector for antenna replacement
 - The antenna has to be professionally installed (please provide method of installation)

which in accordance to section 15.203, please refer to the internal photos.