



To: Federal Communications Commission
Industrie Canada
From: Nortel Networks
Subject: Theory Of Operations
FCC: RVW2231
IC: 332R-2231
Date: 11 Mar 2004

Gentlemen,

Below is a brief explanation of the operation of the Nortel access point Radio

The Nortel radio is an IEEE 802.11 B/G Access point (AP) intended to be professionally installed and configured in corporate and industrial environments. The access point is powered either by an external 48V power supply or via power over Ethernet.

The device utilizes a mini PCI module manufactured by an outside vendor. The modules incorporated into the Omni Access Point radio are IEEE802.11 A/B/G mini PCI modules. However the functionality of the module is determined by the mini PCI slot in which the module is inserted. (See internal photos) The device does not include a "Turbo" mode.

INTERNAL ANTENNA VERSION

The AP utilizes integral antennas on the 802.11 B/G band. The access point effectively includes only a single 2.4GHz patch antenna, however, there are actually two 2.4 GHz antennas internal to the access point chassis. The module switches rapidly between the two antennas and when a signal is detected, the access point uses the antenna offering the best transmission characteristics. At any one time, there is only one antenna connected to the internal PCI module.

The effective gain of the 2.4 GHz internal antenna path (the antenna switch and the antenna itself) is 6.8dBi. The diagrams below outline the RF path from the output of the mini PCI module to the integral antennas within the access point. In the internal antenna version shown below, the software prohibits the switching of the FET antenna switches.

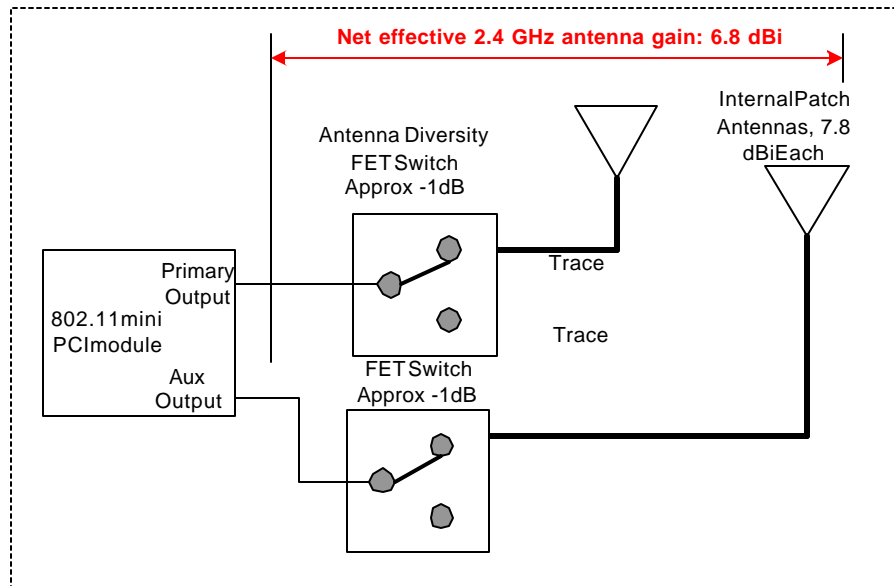

2.4 GHz RF Block Diagram (Internal Antenna Version)

INTERNAL/EXTERNAL ANTENNA VERSION

Additionally, there is a version of the access point which allows connection of external antennas. When External antennas are connected to the access point, the configuration software switches the internal antenna switches into the EXT position. The antenna diversity functionality described earlier works in the same manor for the external antennas. The external antennas used with the access point must be "patch" type antennas and have a net effective gain (antenna gain - cable loss) equal to 6.8 dBi or less. At any one time, ONLY the internal or external antennas may be selected. It is NOT possible to configure the access point to rapidly toggle between external and internal antennas.

The only difference between the internal only version and the internal / external version of the access point is the addition of a small coax cable to an external 15.203 compliant antenna connector in the chassis.

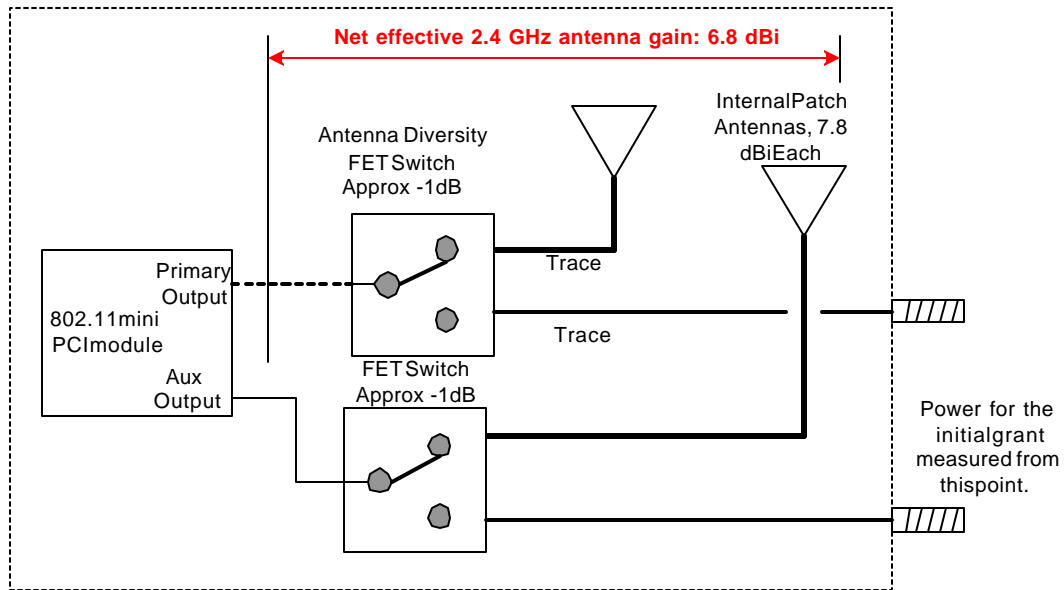

2.4 GHz RF Block Diagram (Internal / External Antenna Version)

Additionally, the device has been tested for compliance to the FCC Part 15 Class A limits. A report has been prepared and is on file at Nortel Inc.

If any further information is required, please do not hesitate to contact me at the email address below.

David Waitt
Consultant representing Nortel
david@waitt.us