

**FCC Part 15, Subpart E, UNII (Part 15.401)
Class II Permissive Change Application**

**Industrie Canada RSS-210
Reassessment Request**

**EMI Test Report
on
IEEE 802.11 Access Point.
Models: 2232 & 2232INT**

**FCC ID: RVW2230W
IC ID: 332R-2230W
Report # NORT_2230_PC**

Prepared by:
David Waitt
202 Calvert Drive #217
Cupertino, Ca. 95014
david@waitt.us
(408) 832 7053

Table of Contents

Section	Page
GENERAL INFORMATION	4
PERMISSIVE CHANGE SUMMARY / DETAILED PRODUCT INFORMATION	5
The access point radio is an IEEE 802.11 A/B/G Access point (AP) intended to be professionally installed and configured in corporate and industrial environments. There are two versions of the AP	5
Testing was performed as indicated below to verify the continued compliance of the access points. All of the tests were performed at the power levels specified in the original test reports.	6
DETAILED PRODUCT INFORMATION / OPERATIONAL DESCRIPTION.....	7
Internal Antenna Version	7
Internal / External Antenna Version	8
REPORT ORGANIZATION AND RESULTS SUMMARY	9
TEST FACILITIES	10
EQUIPMENT LISTS	11
Instrument Calibration	11
Elliott Test Equipment	11
Additional Test Equipment	11
TEST METHODS.....	12
TEST RESULTS	13
802.11 A Maximum RF Power Output at Antenna Terminals.....	14
RF TRANSMIT POWER SUMMARY RESULTS:.....	14
The data highlighted on RED above is not applicable after this permissive change is granted due to the fact that this device will be reclassified as an ISM device for operation in this band (5.725 - 5.825 MHz).....	14
Power Spectral Density	15
Power Spectral Density Summary Results:	15
Power Spectral Density Plots.....	16
Out of band Spurious Emissions & 5.15 - 5.35 GHz Bandedge	18
Out of band Spurious Emissions Results Summary:	18
UUT Transmitting on 5180MHz	19
UUT Transmitting on 5260MHz	20

UUT TRANSMITTING ON 5320MHZ 21

Out Of Band Emissions / Radiated Emissions in Restricted bands22
 Radiated Emissions in Restricted Bands Test Setup..... 23

Radiated Emissions in Restricted Bands Test Results..... 24

UUT Transmitting with 14 dBi Panel antenna S51514WP36RTN..... 24

UUT Transmitting on 5180 with 14 dBi Panel antenna S51514WP36RTN 25

UUT Transmitting on 5260 with 14 dBi Panel antenna S51514WP36RTN 25

UUT Transmitting on 5260 with 14 dBi Panel antenna S51514WP36RTN 25

UUT Transmitting with 9 dBi Omni antenna MFB58009 26

UUT Transmitting on 5180 MHz with 9 dBi Omni antenna MFB58009..... 27

UUT Transmitting on 5260 MHz with 9 dBi Omni antenna MFB58009..... 28

UUT Transmitting on 5320 MHz with 9 dBi Omni antenna MFB58009..... 29

UUT Transmitting with 6 dBi Omni antenna S5153WPBX36RTN..... 30

UUT Transmitting on 5180 with 6 dBi Omni antenna S5153WPBX36RTN..... 31

UUT Transmitting on 5260 with 6 dBi Omni antenna S5153WPBX36RTN..... 32

UUT Transmitting on 5320 with 6 dBi Omni antenna S5153WPBX36RTN..... 33

Radiated Emissions in Restricted Bands at the Band Edges. 34

RADIATED EMISSIONS AT THE BAND EDGES SUMMARY TABLE 35

Measured with the Cushcraft 14 dBi panel antenna S51514WP36RTN 35
 5.15GHz Bandedge, -dBc (Peak)..... 36
 5.15GHz Bandedge, -dBc (Avg)..... 36
 5.15GHz Bandedge, BW Delta (Peak) 37
 5.15GHz Bandedge, BW Delta (Avg) 37
 5.35GHz Bandedge, -dBc (Peak)..... 38
 5.35GHz Bandedge, -dBc (Avg)..... 38
 5.35GHz Bandedge, BW Delta (Peak) 39
 5.35GHz Bandedge, BW Delta (Avg) 39

General Information

Unit(s) Under Test: Nortel Networks access point
Model: 2232 & 2232 INT
Product Description: IEEE 802.11A / B / G Access point

FCC ID: RVW2230W
IC ID: 337R-2230W

Tested For: Nortel Networks
4655 Great America Parkway
Santa Clara, CA 95054

Tested At: Elliott Laboratories
684 West Maude Ave
Sunnyvale, CA 94086

Tested By: Yalda Noor, Test Engineer, Elliott Laboratories
Juan Martinez, Test Engineer, Elliott Laboratories
David Waitt, (Independent Consultant)

Test Specifications: FCC CFR 47, Part Subpart E, (15 401 UNII)
IC RSS-210 6.2.2.(O)

Test Date: Feb 2005

Requested Certification: FCC Part 15 Subpart E Permissive Change Application
Industrie Canada RSS-210 Reassessment Request

Permissive Change Summary / Detailed Product Information

The access point radio is an IEEE 802.11 A/B/G Access point (AP) intended to be professionally installed and configured in corporate and industrial environments. There are two versions of the AP

- Internal Antennas only
- Internal / External Antennas

The purpose of this permissive change is to authorize additional external antennas to be used with the external antenna version of the access point. These additional antennas consist of both, antennas of a different type than what was originally certified and antennas with higher gain than what was originally certified.

While this permissive change seeks to follow FCC policy and allow antennas of the same type of equal or lesser gain to be used with the product from various manufacturers, a table of the desired antennas and those that were actually tested with the access point is below.

In addition to allowing the use of additional external antennas, this permissive seeks to reclassify the 5.725 - 5.825 from UNII to ISM for both types of access points, (internal and external antenna types)

Additionally, this permissive change requests authorization for operation within the band 5825MHz to 5850MHz for both types of access points, (internal and external antenna types)

Only those test results from the 5 GHz antennas tested on the UNII bands are contained in this report. The results for the 2.4 GHz antennas and the 5 GHz antennas tested in the 5.725 - 5.85 band are contained in the ISM report as part of this permissive change

Mfg	Mfg PN	Freq Band (MHz)	Net Gain (dBi)	Type	Comment	C2PC Tested
MaxRad	MFB58009	5.725 - 5.875	9.0	Omni	Omni directional	YES
Cushcraft	SQ5723PN36RTN	5.725-5.875	3.1	Omni	Classified as Omni	Covered with MaxRad MFB58009
Cushcraft	SQ5153PN36RTN	5.15-5.35	3.1	Omni	Classified as Omni	Covered with S5153WPBX Testing
Cushcraft	SQ5153WP36RTN	5.15-5.875	3.0	Omni	Classified as Omni	Covered with S5153WPBX Testing
Cushcraft	S5703BHN36RTN	5.725-5.875	4.3	Omni	Omni directional	Covered with MaxRad MFB58009
Cushcraft	S5153WPBX36RTN	5.15-5.875	6.0	Omni	Omni directional	YES
Cushcraft	S5153BHN36RTN	5.15-5.35	4.3	Omni	Omni directional	Covered with S5153WPBX Testing
Cushcraft	RTN5150MRA	5.15-5.875	2.0	Omni	Omni directional	Covered with S5153WPBX Testing
Cushcraft	S51514WP36RTN	5.15-5.875	14.0	Patch	Patch Directional	YES
Cushcraft	S51512MPN36RTN	5.15-5.35	12.0	Patch	Patch Directional	Covered with S51514WP Testing
Cushcraft	S57212MPN36RTN	5.725-5.875	12.0	Patch	Patch Directional	Covered with S51514WP Testing
Max Rad	MFB24008NM	2.4 - 2.5	8.0	Omni	Omni Directional	YES
Cushcraft	S2403BHN36RTN	2.4 - 2.5	4.5	Omni	Omni Directional	Covered with MFB24008 Testing
Cushcraft	RTN2400MRA	2.4 - 2.5	2.0	Omni	Omni Directional	Covered with MFB24008 Testing
Maxrad	MP24103XFPTMSMA	2.4 - 2.5	13.0	Panel	Panel	YES
Cushcraft	SL2402PN36RTN	2.4 - 2.5	2.0	Panel	Panel	Covered with MP24103XFPTesting
Cushcraft	S2402DSN36RTN	2.4 - 2.5	2.0	Panel	Dual 2402 Panel	Covered with MP24103XFPTesting
Cushcraft	S2406PN36RTN	2.4 - 2.5	5.5	Panel	Panel	Covered with MP24103XFPTesting
Cushcraft	S2406DSPN36RTN	2.4 - 2.5	6.5	Panel	Dual 2406 Panel	Covered with MP24103XFPTesting
Cushcraft	S2409PN36RTN	2.4 - 2.5	8.8	Panel	Panel	Covered with MP24103XFPTesting
Cushcraft	SQ2403PN36RTNMO	2.4 - 2.5	3.0	Unique	Unique pattern	YES

Testing was performed as indicated below to verify the continued compliance of the access points. All of the tests were performed at the power levels specified in the original test reports.

TEST	Performed (Y / N)	Justification
Radiated emissions in Restricted bands / Out of band emissions	Y	It is reasonable to assume that the radiated emissions performance of the AP may be affected by utilizing an different antenna
5 GHz Power Spectral Density	Y	Because of the reclassification on the upper 5 GHz band, the PSD specification is different. Even though the ISM specification is less stringent, this parameter was re-tested.
RF Transmit power	N	While the transmit power was verified for the radiated emissions testing, to ensure it is the same as the original grant, it is not presented in this report
Bandwidth	N	There is no reason to expect that the use of a different antenna would affect the bandwidth of the signal
Line Conducted Emissions	N	There is no reason to expect that the use of a different antenna would affect the AC line conducted emissions of the access point

Detailed Product Information / Operational Description

Information from original certification application, FOR REFERENCE ONLY

The access point radio is an IEEE 802.11 A / B / G Access point is intended to be professionally installed and configured in corporate and industrial environments.

The device does not include a “Turbo” mode.

The access point is powered either by an external 48V power supply or via power over Ethernet (POE)

Additionally, the device has been tested for compliance to the FCC Part 15 Class B limits. A report has been prepared and is on with the manufacturer.

Internal Antenna Version

The Internal Antenna Only version of the access point is NOT affected by the External Antenna request portion of this permissive change

The access point utilizes integral antennas on the 802.11 A / B / G bands. The access point includes two integral 5 GHz patch antennas pointing 180° from each other to create a somewhat omni directional 5 GHz pattern. The access point effectively includes only a single 2.4GHz patch antenna (the 2.4 GHz antenna is discussed in the 802.11 B report). The effective gain of the 5 GHz antenna path (the power divider and the antenna itself) is 7.4dBi. The diagrams below outline the RF path from the output of the mini PCI module within the access point to the integral antennas within the access point (Note that only the Subpart E, 15.401 UNII 5 GHz portion is covered by this particular report)

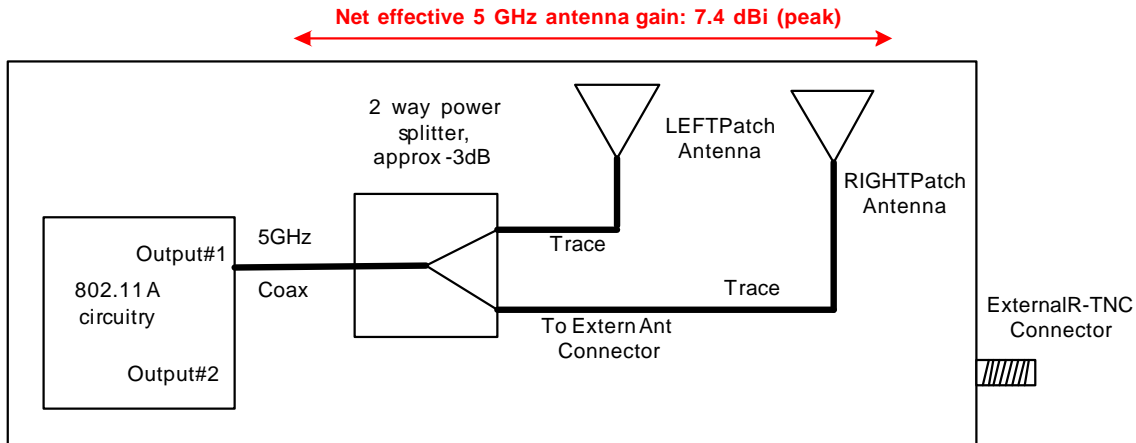

5 GHz RF Path Block Diagram (Internal Antenna Version)

Internal / External Antenna Version

The second version of the access point allows the connection of an external 5 GHz antenna. This option can be selected by the configuration software. If an external 5 GHz antenna is used, it is permanently attached to the access point to meet FCC “Integral” antenna requirements. The maximum gain of the external antenna is below 7.4 dBi net effective gain (antenna gain - cable loss)

Note that in contrast to the internal antennas; only ONE external 5 GHz antenna can be used. The configuration software cannot be configured to rapidly switch between the internal and external antenna.

The only difference between the two versions is the inclusion of a short coax and external connector in the housing.

The access point was NOT tested with external antennas because:

- 1: The internal and external antennas will be of the same type (Patch antenna)
- 2: The external antennas will be of equal or lower net effective gain than the internal antennas.

This test methodology adheres to the current policy of testing the product with the highest gain antenna of each type that will be used with the product.

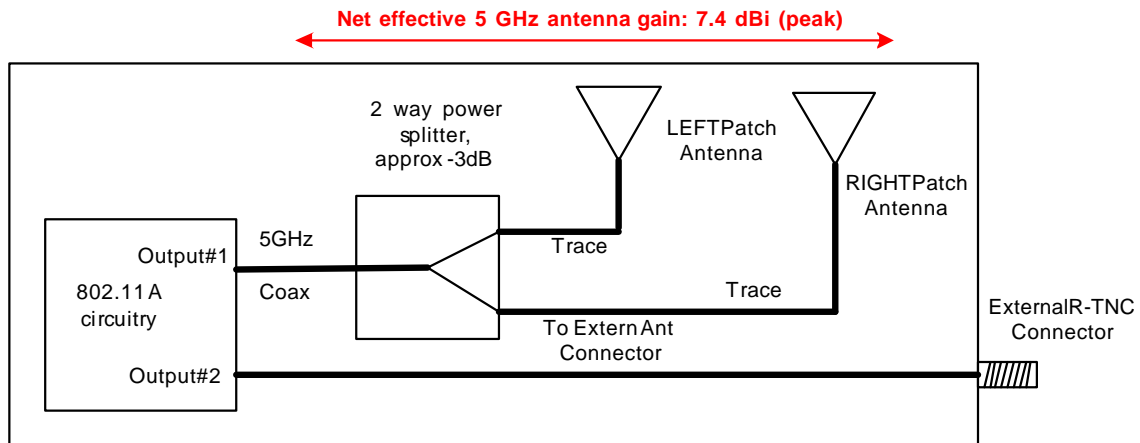

5 GHz RF Path Block Diagram (Internal / External Antenna Version)

Report Organization and Results Summary

This report presents the results of the tests that verify compliance with FCC Part 15.401 and Industrie Canada RSS-210. Though this product must comply with FCC Part 15.247 (for 802.11 B/G) as well, only the 15.401 (UNII) results are contained in this report. The compliance information for Part 15.247 is contained in a separate report.

A brief results summary of all the in this report is below.

Part 15 Paragraph	Test	Results
15.407(a)(5)	Power Spectral Density (5.15 - 5.25)	-4.915 dBm/1MHz
15.407(a)(5)	Power Spectral Density (5.25 - 5.35)	2.437 dBm/1MHz
15.407(b)(1)	Out of Band Emissions Emissions in restricted bands (1319MHz Xmitting on 5320MHz into 9dBi Omni)	.1 dB below limit

Test Facilities

All of the certification tests were performed at:

Elliott Labs
684 West Maude Ave
Sunnyvale, CA 94086

General:

Final radiated test measurements were taken in Feb 2005 at Elliott Laboratories Chamber #5

The test site contains separate areas for radiated and conducted emissions testing. Pursuant to section 2.948 of the Rules, construction, calibration, and equipment data has been filed with the Commission.

The FCC recommends that ambient noise at the test site be at least 6 dB below the allowable limits. Ambient levels are below this requirement with the exception of predictable local TV, radio, and mobile communications traffic. The test site contains separate areas for radiated and conducted emissions testing. Considerable engineering effort has been expended to ensure that the facilities conform to all pertinent FCC requirements.

OATS:

The FCC has determined that radiation measurements made in a shielded enclosure are not suitable for determining levels of radiated emissions. Radiated emissions are performed in an open field environment. The test site is maintained free of conductive objects within the CISPR defined elliptical area incorporated in ANSI C63.4 Guidelines.

Antenna, Antenna Mast and Turntable

The Horn antennas that are used to measure radiated emissions above 1000MHz are mounted on a non-conductive antenna mast equipped with a motor drive to vary the antenna height.

ANSI C63.4 specifies that the test height above the ground plane shall be 80cm unless the equipment is intended to be floor mounted. During the radiated emissions tests the equipment is positioned on a motorized turntable in conformance with the ANSI requirement.

Equipment Lists

Instrument Calibration

All test equipment is regularly checked to ensure that performance is maintained in accordance with the manufacturer's specifications. All antennas are calibrated at regular intervals with respect to tuned half-wave dipoles. An exhibit of this report contains the list of test equipment used and calibration information.

The following test equipment was used to perform the testing

Elliott Test Equipment

<u>Manufacturer</u>	<u>Description</u>	<u>Model #</u>	<u>Asset #</u>	<u>Cal Due</u>
Hewlett Packard	Microwave Preamplifier, 1-26.5GHz	8449B	263	09-Jan-06
EMCO	Horn Antenna, D. Ridge 1-18GHz	3115	868	20-Apr-06
Hewlett Packard	Microwave EMI test system (SA40, 9kHz - 40GHz) Fremont	84125C	1410	26-Mar-05
Hewlett Packard	EMC Spectrum Analyzer 9KHz-26.5GHz, non programmable	8563E	284	15-Mar-05
Rohde & Schwarz	Power Meter, Single Channel	NRVS	1290	22-Apr-05
Rohde & Schwarz	Peak Power Sensor 100uW - 2 Watts	NRV-Z32	1536	22-Apr-05

Additional Test Equipment

<u>Item</u>	<u>Desc.</u>	<u>Manufacturer</u>	<u>Model</u>	<u>S/N</u>	<u>Cal due date</u>
Spectrum Analyzer		Agilent	E4440A	MY43362314	16 Jan 2006

Test Methods

Many of the tests are performed at a low, middle and high channel of the applicable band. The typical frequencies used for the test for each band are listed below.

UNII 802.11 A	
5.15 – 5.25 GHz & 5.25 – 5.35 GHz	
Channel	Freq(MHz)
Low	5180
Mid	5260
High	5320

In order to comply with the maximum allowable RF power requirement in the 5.15 - 5.25 GHz band, the power setting (and thus the transmit power) is lower in this band then in the other two UNII bands. The maximum power setting that yielded compliance will be programmed into the configuration firmware of the access point to ensure the maximum possible power setting will be correct for each band.

The following tests are performed using the basic test setup shown below. In several cases, the EUT was running special diagnostic firmware to allow it to transmit random data on a particular channel indefinitely.

Part 15	Test
15.407(a)(5)	Power Spectral Density
15.407(b)(1)	Out of Band Emissions (5.15 – 5.25)
15.407(b)(1)	Out of Band Emissions (5.25 – 5.35)
15.407(b)(1)	Out of Band Emissions (5.725 – 5.825)

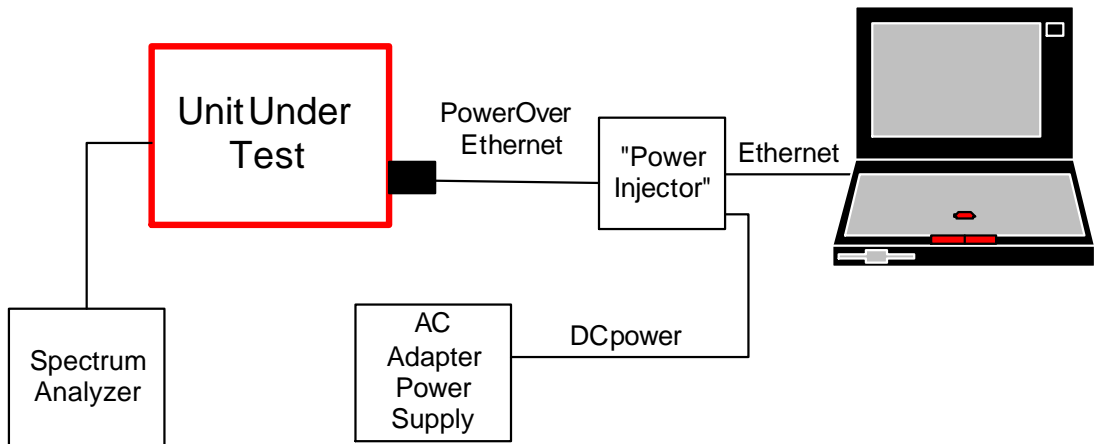

Basic Conducted RF Bench Test Setup

Unless otherwise noted, the support equipment for the bench tests is listed below.

Support Equipment				
Description	Model number	FCC ID	Manufacturer	Power Cable
Laptop	A20	DOC	IBM	Laptop PS
Test Software	Atheros Radio Test		Atheros	
48VDC AC adapter	Generic		Generic	Standard Twin lead DC wire

Test Results

Detailed test procedures and test results are contained in the following sections. In cases where the test setup differs from the Conducted RF test setup shown above, the test setup is also presented.

Test Conditions			
Temperature	23 C	Humidity:	52%
ATM pressure	1019 mBar	Grounding:	None
Tested By	David Waitt	Date of Test:	Feb 2005
Test Reference	Refer to individual test results		
Tested Range	Test Dependent		
Test Voltage	48 VDC to the access point		
Modifications	No modifications were made to the unit during the tests		

802.11 A Maximum RF Power Output at Antenna Terminals
Information from original certification application, FOP REFERENCE ONLY

Specifications:

FCC Specification: Paragraph(s): 15.401(a)(1), 15.401(a)(2), 15.401(a)(3)

IC Specification: 6.2.2.(q1)i

← Net effective 5 GHz antenna gain: 7.4 dBi (peak) →

Procedure:

The test was conducted by connecting the external antenna output of the AP directly to a spectrum analyzer. This measured power is therefore equal to the power into the power splitter when using the internal antennas and the same as the power into the external antenna if applicable.

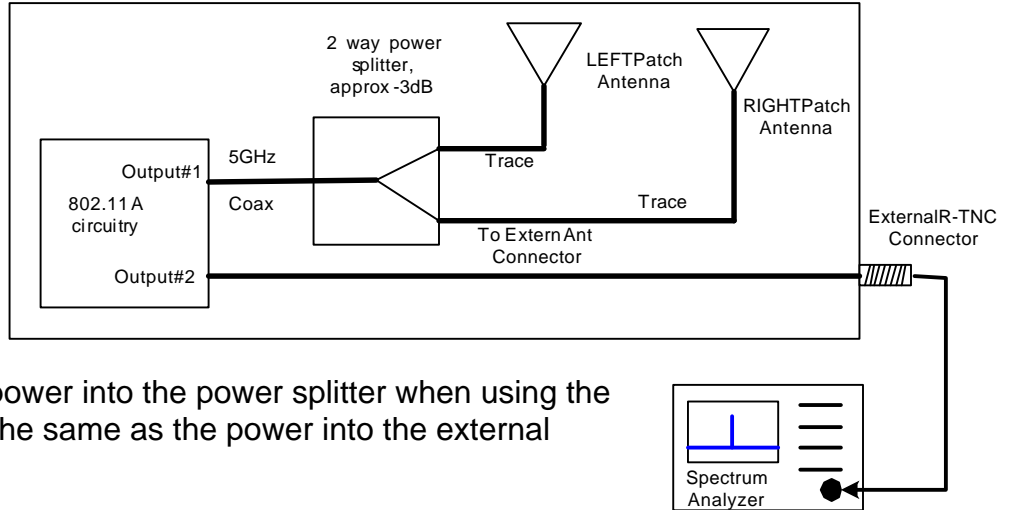

The settings that were used during this certification testing will be entered into the firmware of the access point. These firmware configuration limits will ensure that the power levels are not exceeded.

Power measurements were performed with a spectrum analyzer using channel power integration over the 26 dB bandwidth. This was achieved by selecting trace “max hold”. The measurements were made per FCC “Method 1” outlined in public notice DA 02-2138 dated 30 Aug 2002.

RF Transmit Power Summary Results:

INTERNAL or EXTERNAL ANTENNA								
Frequency MHz	Measured 26 dB Channel Power at Ext Ant connector		Power Spec dBm	Delta dBm	Maximum EIRP (Ant gain = 7.4dBi MAX)		Maximum EIRP Spec Pout+6dBi dBm EIRP	Delta dB
	dBm	mW			dBm	mW		
5180	15.01	31.70	17.00	1.99	22.41	174.18	23.00	0.59
5240	15.33	34.12	17.00	1.67	22.73	187.50	23.00	0.27
5260	20.81	120.50	24.00	3.19	28.21	662.22	30.00	1.79
5320	20.74	118.58	24.00	3.26	28.14	651.63	30.00	1.86
5745	19.55	90.16	30.00	10.45	26.95	495.45	36.00	9.05
5765	19.69	93.11	30.00	10.31	27.09	511.68	36.00	8.91
5805	19.35	86.10	30.00	10.65	26.75	473.15	36.00	9.25

The data highlighted on RED above is not applicable after this permissive change is granted due to the fact that this device will be reclassified as an ISM device for operation in this band (5.725 - 5.825 MHz)

Power Spectral Density

Specification

FCC Specification: Paragraph 15.407(a)(5)

IC Specification: 6.2.2(q1)i

Procedure:

The test setup was configured as shown in the conducted test setup. The UUT was configured to continuously transmit random data packets. Initially the bandwidth of the entire channel was examined. Using MAX HOLD and peak search, the frequency with the maximum power was determined. The measurements were made using RBW = 1MHz, VBW >= 1MHz

The Power spectral density limits are shown below:

5.15-5.25GHz: 4dBm/MHz

5.25-5.35GHz 11dBm/MHz

However, these limits must be reduced 1 dB for every dB that the maximum antenna gain exceeds 6.0dBi. Since the maximum antenna gain used with the access point (in this permissive change request) is 14.0 dBi. These PSD limits must be reduced by 8 dB. This reduced limit is shown in the table below.

The power spectral density was measured at the designated test channels with the appropriate power level (as determined in the for the given test channel.

Power Spectral Density Summary Results:

Frequency (MHz)	P.S.D. (dBm/MHz)	FCC Limit (dBm/MHz) Corrected for excess gain over 6 dBi	Delta (dB)
5180	-4.314	-4.0	.314
5260	2.783	3.0	.217
5320	2.644	3.0	.356

Power Spectral Density Plots

5180MHz PSD

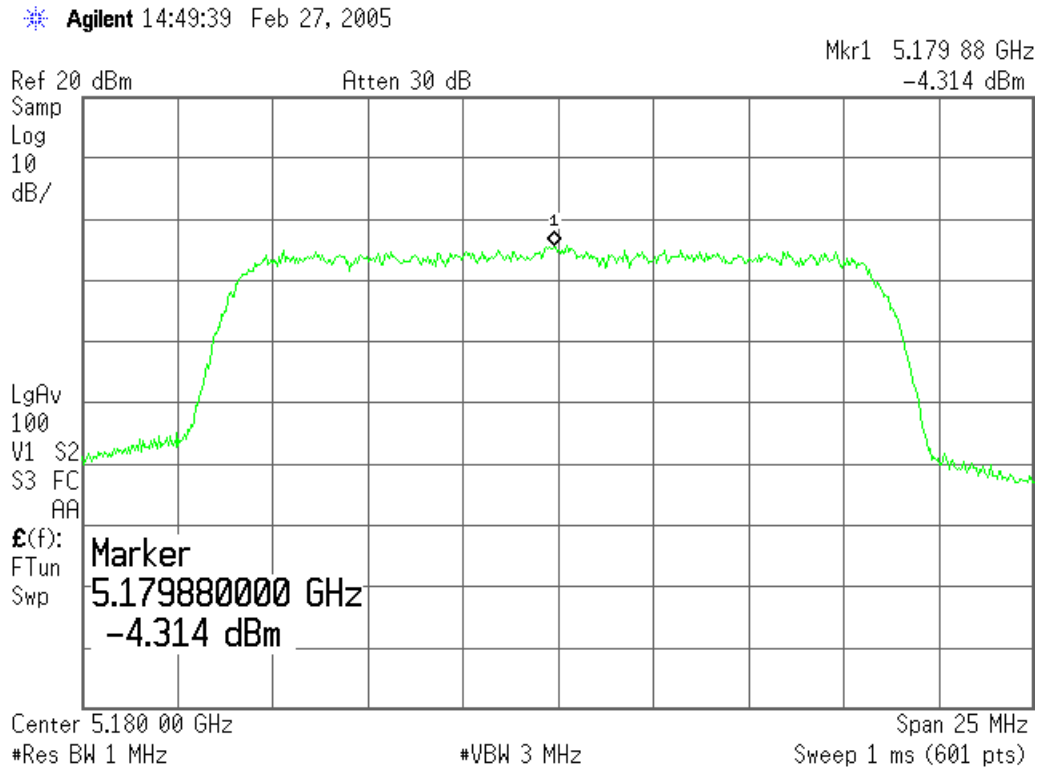

5260MHz PSD

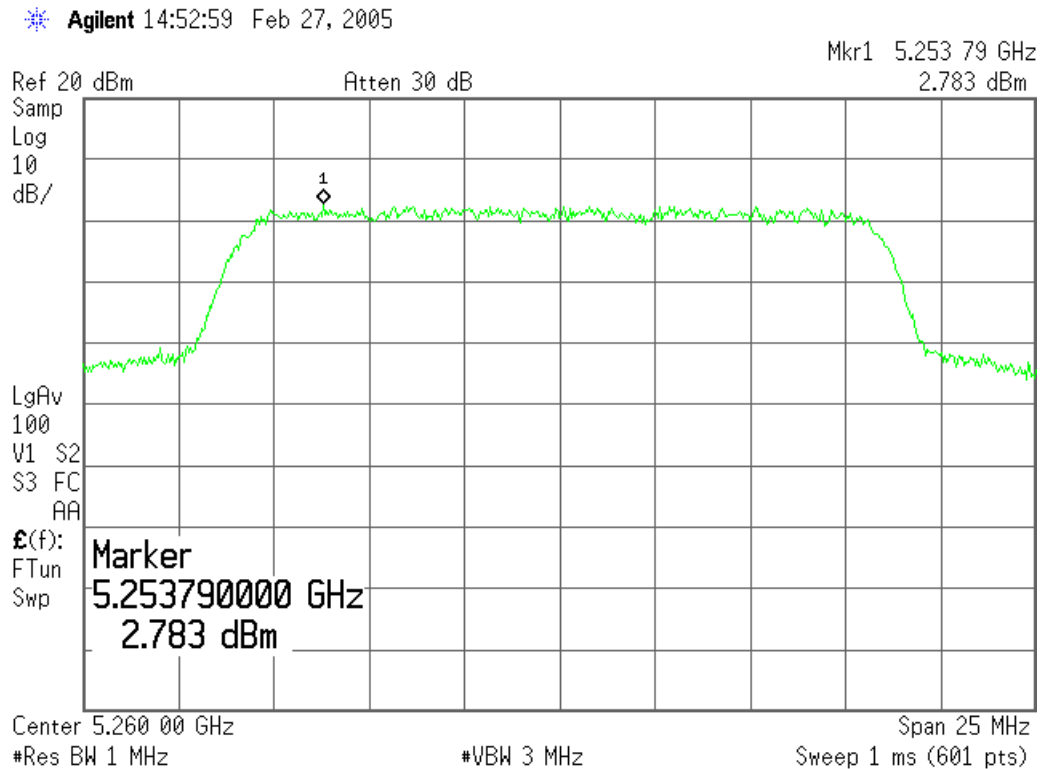

Agilent 14:55:24 Feb 27, 2005

Mkr1 5.319 75 GHz
2.644 dBm

5320MHz PSD

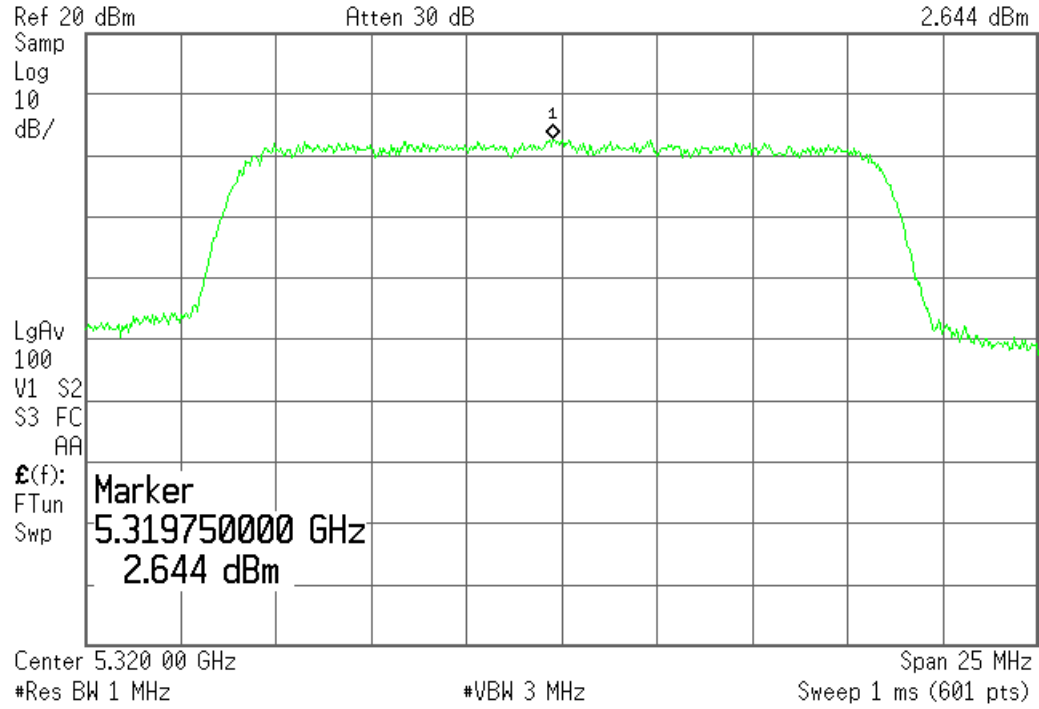

Out of band Spurious Emissions & 5.15 - 5.35 GHz Bandedge

Specification

FCC Specifications: Paragraphs 15.407(b)(1), 15.407(b)(2),

IC Specification: 6.2.2.(q1)

Procedure:

For signals in the bands above and below the 5.15 - 5.35 GHz band, conducted measurements were made at the external antenna connector. The test was configured as shown in the Conducted RF test setup. The UUT was configured to transmit continuous random data packets on the standard channel closest to the band edge being examined. The UUT was configured to the appropriate power setting depending on the test channel.

Since the specification is in EIRP, the appropriate specification limit was adjusted account for the maximum allowable antenna gain.

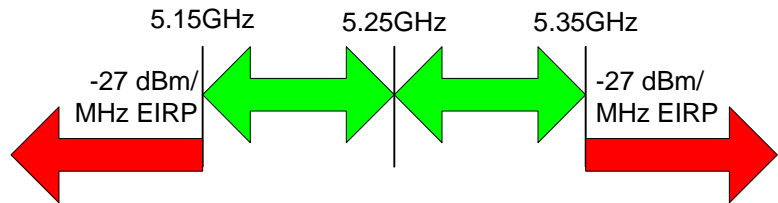

Out Of Band Spurious Emissions Limits

Limit Calculation:

Antenna Gain:

7.4 dBi

Out of band signal limit: -27dBm/MHz EIRP (for signals not in a restricted band)

Conducted limit: -27dBm/MHz - 14 dBi = **-41dBm/MHz EIRP**

This assumes a maximum external antenna gain of 14 dBi.

In the some instances, the measured emission is a harmonic of the fundamental and is examined in detail in the Radiated Emissions Is Restricted Bands Test.

Out of band Spurious Emissions Results Summary:

Tabular results below are followed by plots of the conducted emissions.

Highest Measured Emission Within The Band

Xmit Freq (MHz)	30 MHz - 5.15 GHz	5.35 - 26.5 GHz	Specification -41 dBm	Delta (dB) (From specification)
5180	-49.379	-50.96	-41	-8.379
5260	-54.117	-54.279	-41	-13.117
5320	-49.363	-46.897	-41	-5.897

UUT Transmitting on 5180MHz

Agilent 21:38:12 Feb 21, 2005

30 MHz - 5.15GHz

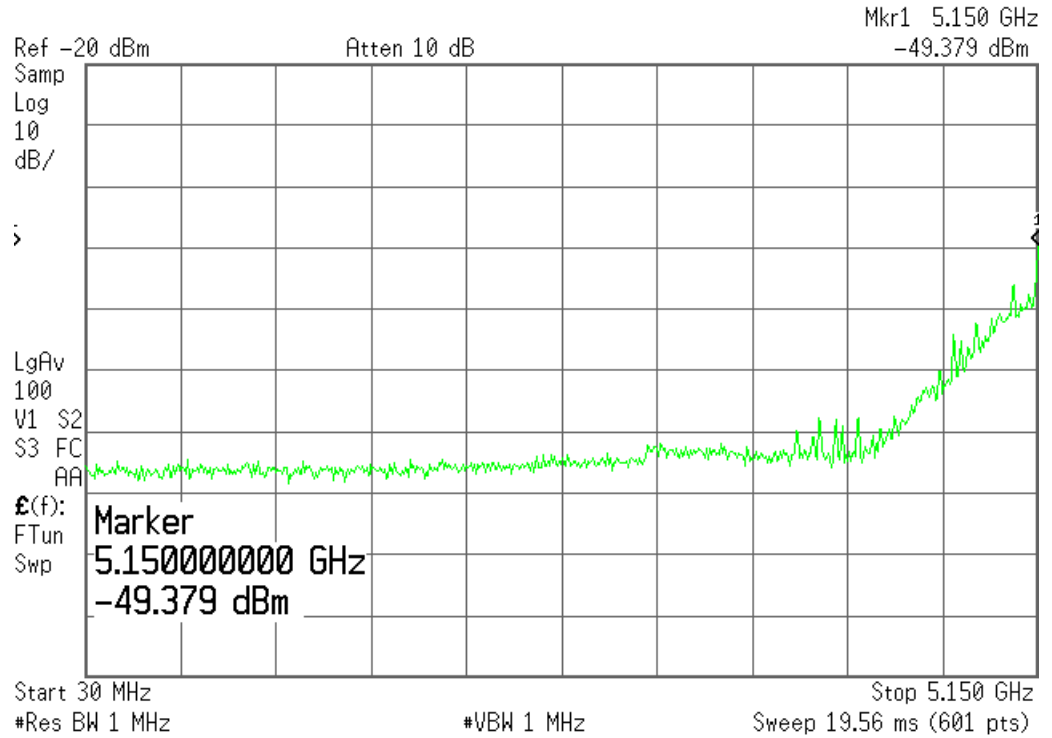

Agilent 21:35:54 Feb 21, 2005

5.15GHz - 26.5GHz

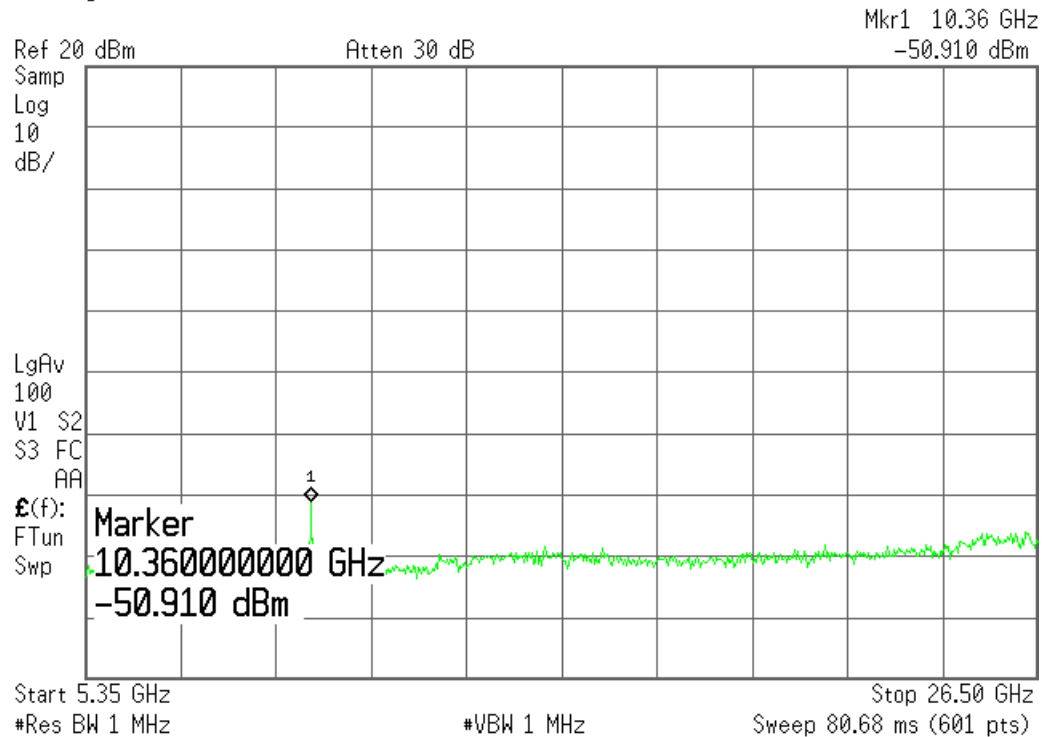

UUT Transmitting on 5260MHz

Agilent 21:47:07 Feb 21, 2005

Mkr1 5.099 GHz
-54.117 dBm

30 MHz -
5.15GHz

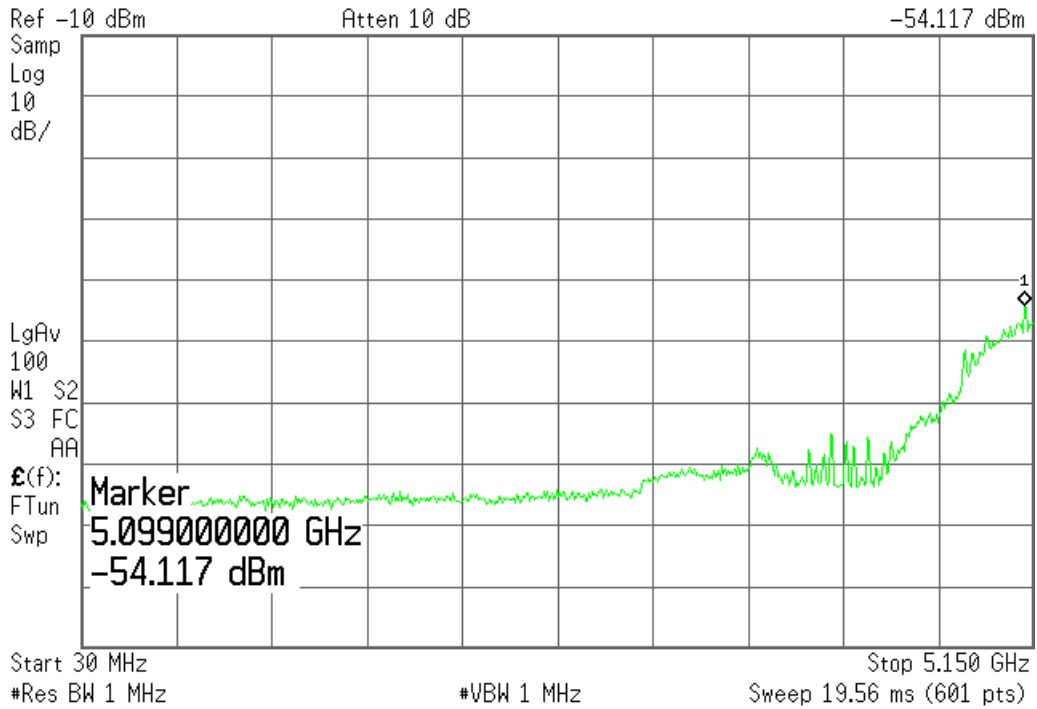

Agilent 21:48:24 Feb 21, 2005

Mkr1 10.53 GHz
-54.279 dBm

5.35 - 26.5 GHz

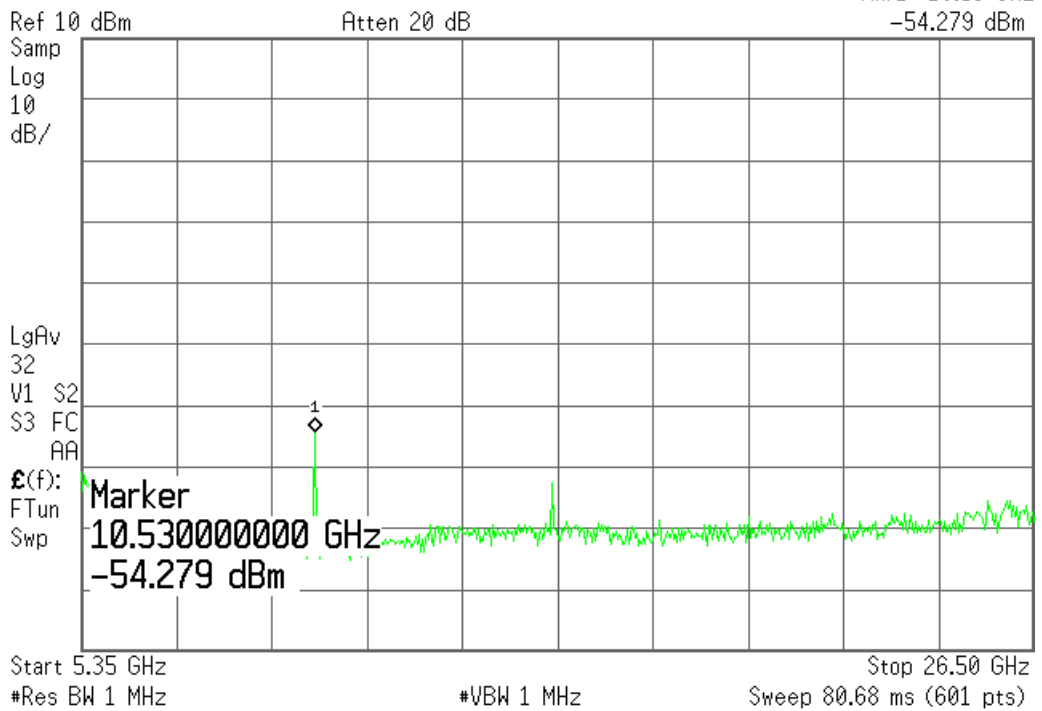

UUT Transmitting on 5320MHz

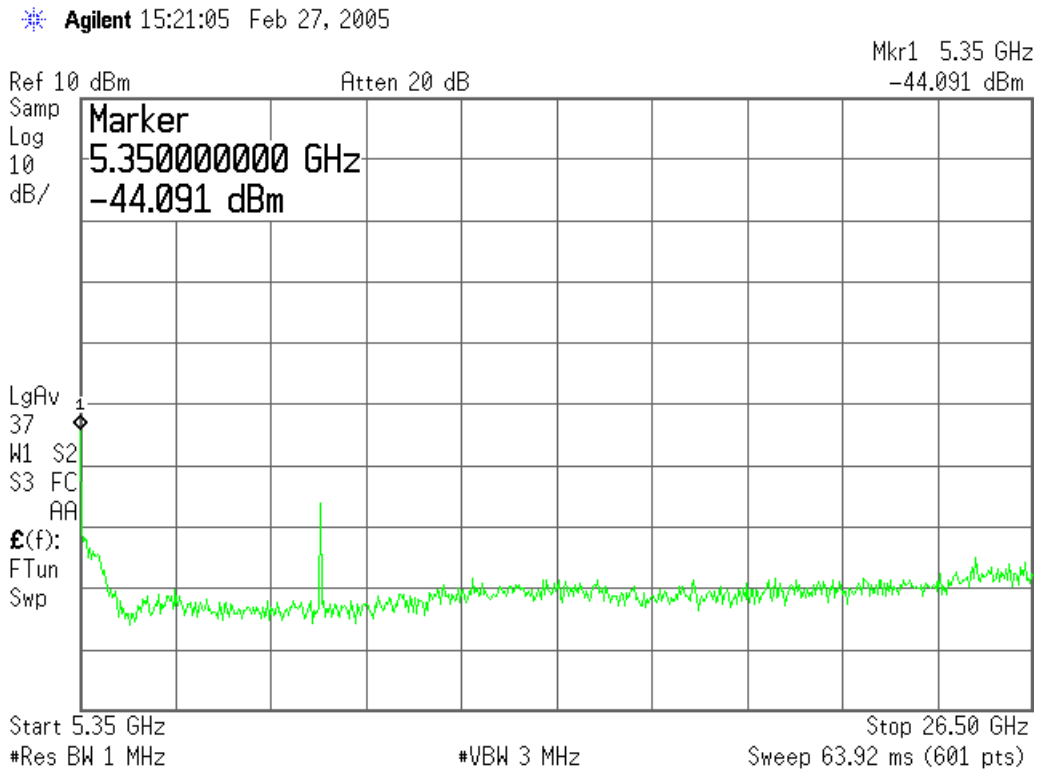

30 MHz - 5.15GHz

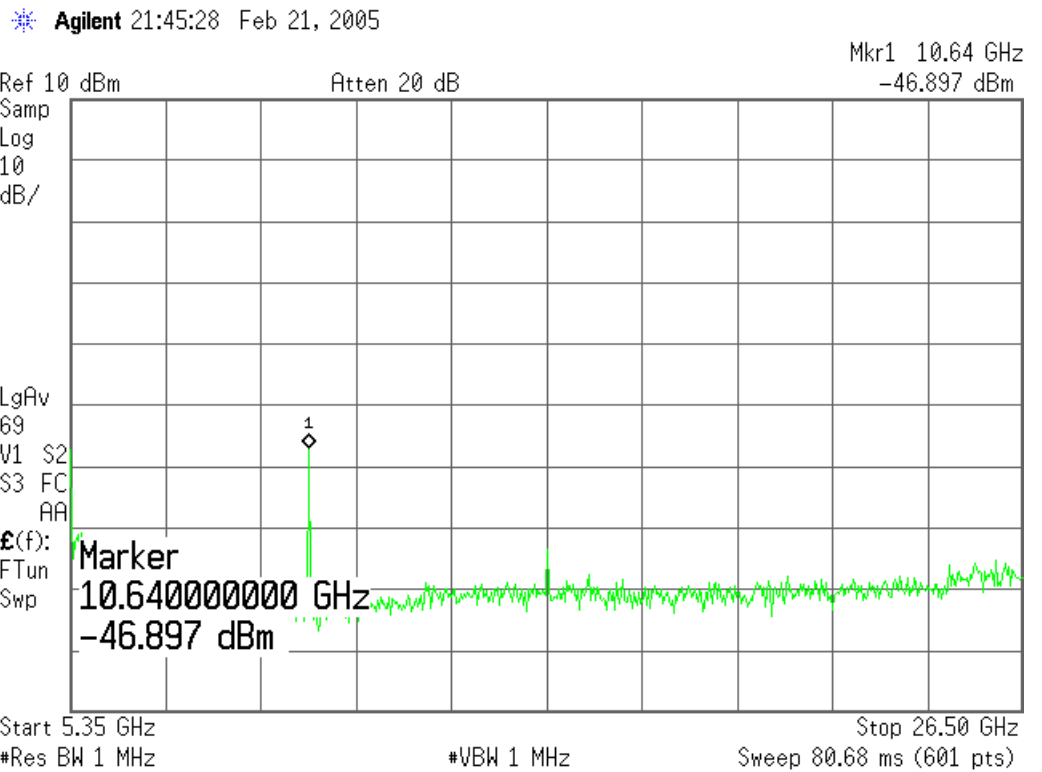

5.35 - 26.5 GHz

Out Of Band Emissions / Radiated Emissions in Restricted bands

Specification:

FCC Specification: Paragraph 15.407(b)(6)

IC Specification: 6.2.2(q1)i 6.2.2.(q1)ii 6.2.2.(q1) iii

Procedure:

This test was conducted in a 5-meter semi anechoic chamber at Elliott Laboratories The unit was placed on a rotating wooden table 80cm above the ground plane. A Horn antenna(s) were secured to a mast 3 meters away. The unit was tested at a low, mid and high channel within the 5.15-5.35GHz band. The UUT was configured to transmit random data. The transmit power was set to the settings outlined in the power setting table in this report. The test equipment was configured as shown below.

The band from 1 to 40 GHz was scanned (40 GHz is the limit of the available test equipment). A high pass filter prior to the pre-amplifier was required to prevent the signal level of the fundamental frequency from overloading the front end of the spectrum analyzer and creating harmonics within the analyzer.

The EUT was rotated 360 degrees and the height of the antenna adjusted from 1 to 4 meters above the ground plane to determine the maximum level of the emission. The level of the harmonic emission was measured in two modes, "Peak" and "Average" .

The maximum spectrum analyzer reading was captured by the automated test software where correction factors (antenna factor, cable loss, pre-amplifier gain, HPF loss...) were then applied to obtain a final corrected measurement.

Fund	2	3	4	5	6	7	8	9	10
5180	10360	15540	20720	25900	31080	36260	41440	46620	51800
5260	10520	15780	21040	26300	31560	36820	42080	47340	52600
5320	10640	15960	21280	26600	31920	37240	42560	47880	53200

15.407(b)(6) Harmonic test table

NOTE: RED indicates a harmonic that falls within a restricted band, the harmonics in gray are NOT in restricted bands.

Radiated Emissions in Restricted Bands Test Setup

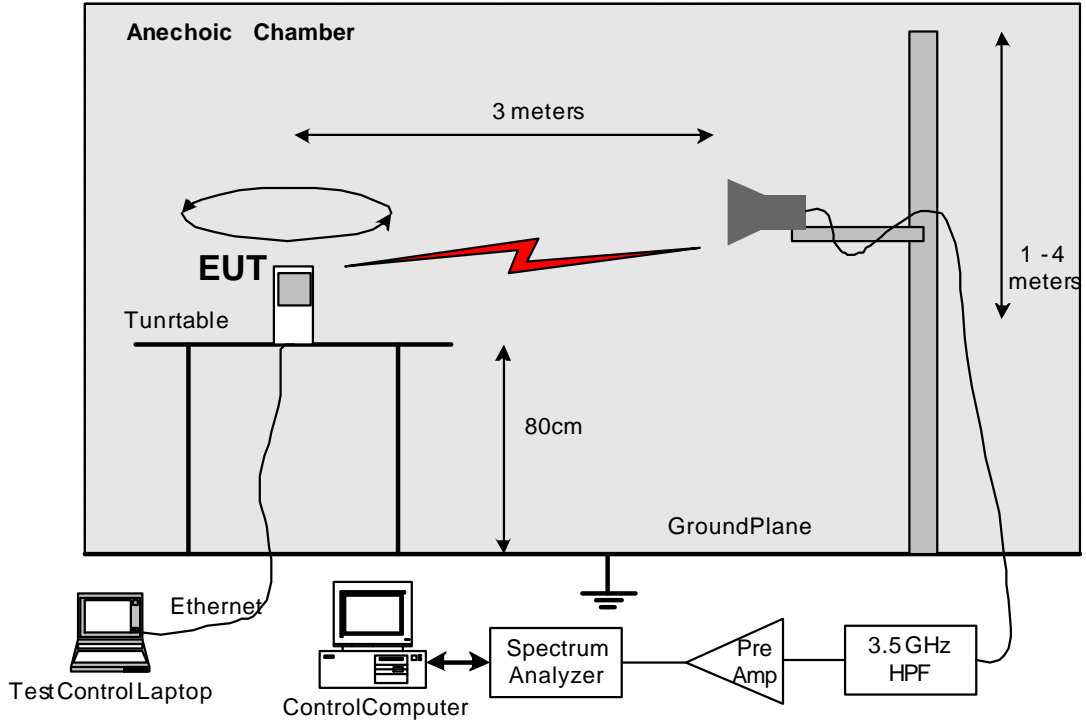

Support Equipment

Description	Model number	FCC ID	Manufacturer	Power Cable
Laptop	A20	DOC	IBM Thinkpad	Laptop PS
Test Software	Atheros Radio Test		Atheros	

Test Conditions

Temperature	22 C	Humidity:	41%
ATM pressure	1018 mBar	Grounding:	None
Tested By	Yalda Noor, Elliott Labs	Date of Test:	Feb 2005
Test Reference	FCC Part 15.205 IC Paragraph RSS210, 6.2.3 (c)		
Setup Method	ANSI C63.4		
Tested Range	1 GHz to 40 GHz		
Test Voltage	48 VDC		
Modifications	No modifications were made to the unit		

Radiated Emissions in Restricted Bands Test Results

There were some emissions detected during the test. The results are below. In cases where the emission was not within a restricted band the Out Of Band Emission limit is applied. No emissions above approximately the third harmonic (16 GHz) were detected. The band up to 40 GHz was examined.

Notes:

Limits for emission is within a restricted band.

- Peak measurements: Resolution and Video BW: 1 MHz, 74 dBuV Limit
- Average Measurements: Resolution BW: 1MHz and Video BW: 10 Hz, 54 dBuV Limit
- Peak measurements: 74 dBuV Limit
- Average Measurements: 54 dBuV Limit

Limits for emission is NOT within a restricted band.

- Measurement settings: Resolution BW = 1MHz and VBW = 3MHz.
Video averaging on (100 samples).
- Limit -27 dBm / MHz EIRP, adjusted to 3M field strength: 68.3 dBuV

For emissions falling in the restricted bands detailed in 15.205 the general limits of 15.209 apply. For all other emissions the limit is EIRP < -27dBm (equivalent to a field strength at 3m of 68.3 dBuV/m)

UUT Transmitting with 14 dBi Panel antenna S51514WP36RTN

Fund Freq	Frequency	Level	Pol	15.209 / 15.247		Detector	Azimuth	Height	Comments
				Limit	Margin				
MHz	MHz	dBuV/m	v/h			Pk/QP/Avg	degrees	meters	
5180	10360.78	60.0	V	68.3	-8.3	PK	79	1.0	Non-restricted
5180	10360.78	56.1	H	68.3	-12.2	PK	186	1.0	Non-restricted
5180	1319.94	43.7	V	54.0	-10.3	AVG	139	1.0	Restricted
5180	1319.94	51.5	V	74.0	-22.5	PK	139	1.0	Restricted
5180	1320.03	43.9	H	54.0	-10.1	AVG	149	1.0	Restricted
5180	1320.03	50.9	H	74.0	-23.1	PK	149	1.0	Restricted
5260	10519.07	58.7	V	68.3	-9.6	PK	75	1.0	Non-restricted
5260	10519.07	64.7	H	68.3	-3.6	PK	192	1.0	Non-restricted
5260	1320.74	44.7	V	54.0	-9.3	AVG	152	1.0	Restricted
5260	1320.74	54.8	V	74.0	-19.2	PK	152	1.0	Restricted
5260	1319.99	42.1	H	54.0	-11.9	AVG	204	1.0	Restricted
5260	1319.99	49.8	H	74.0	-24.2	PK	204	1.0	Restricted
5320	1321.027	42.2	V	54.0	-11.8	AVG	160	1.0	Restricted
5320	1321.027	53.1	V	74.0	-20.9	PK	160	1.0	Restricted
5320	1319.986	45.1	H	54.0	-8.9	AVG	155	1.0	Restricted
5320	1319.986	51.5	H	74.0	-22.5	PK	155	1.0	Restricted
5320	10642.62	41.1	V	54.0	-12.9	AVG	127	1.0	Restricted
5320	10642.62	53.2	V	74.0	-20.8	PK	127	1.0	Restricted
5320	10642.62	40.4	H	54.0	-13.6	AVG	115	1.0	Restricted
5320	10642.62	52.7	H	74.0	-21.3	PK	115	1.0	Restricted

UUT Transmitting on 5180 with 14 dBi Panel antenna S51514WP36RTN

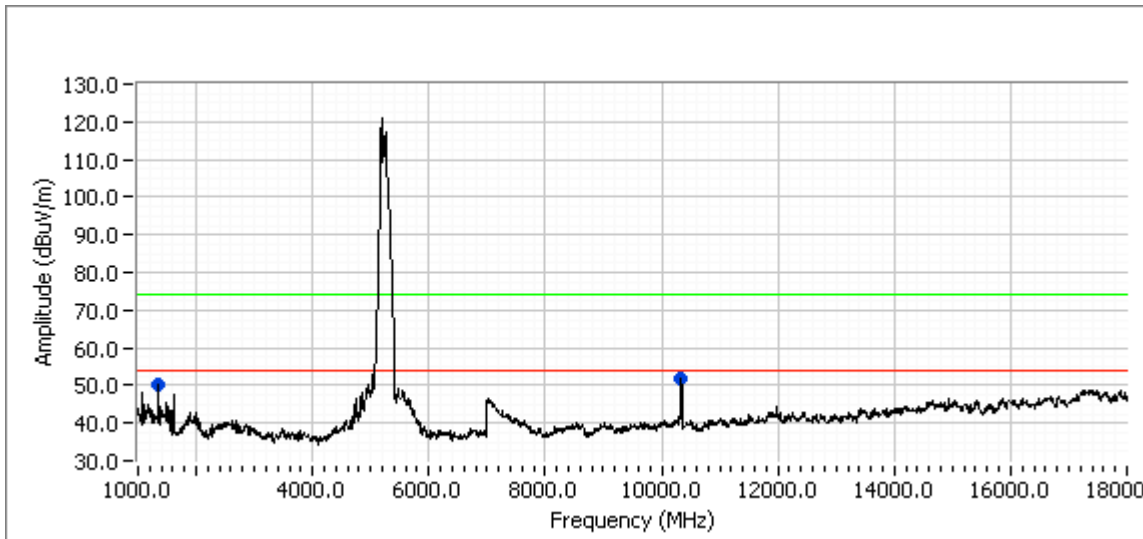

UUT Transmitting on 5260 with 14 dBi Panel antenna S51514WP36RTN

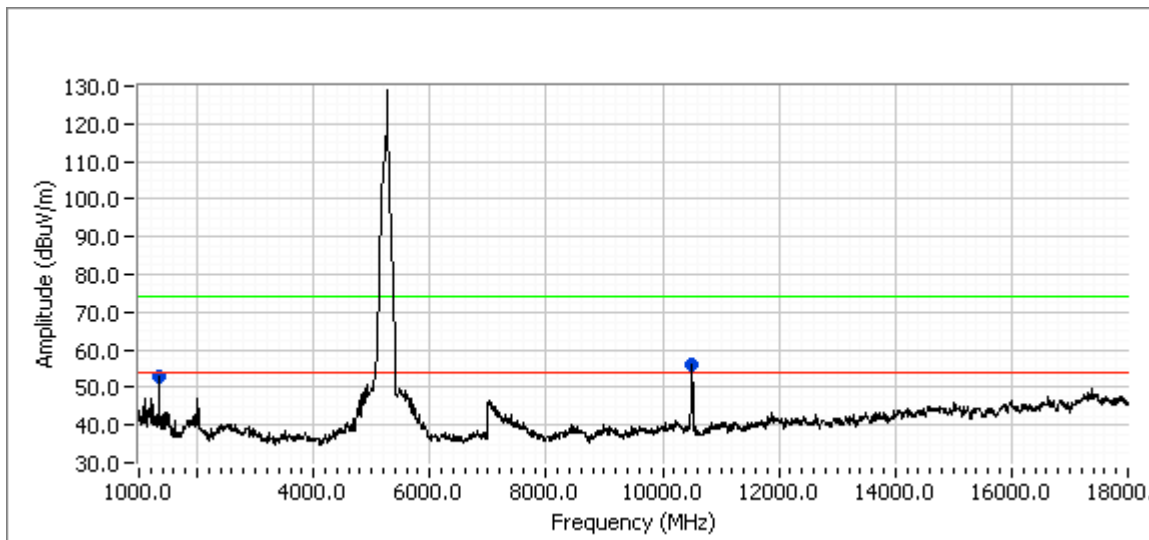

UUT Transmitting on 5260 with 14 dBi Panel antenna S51514WP36RTN

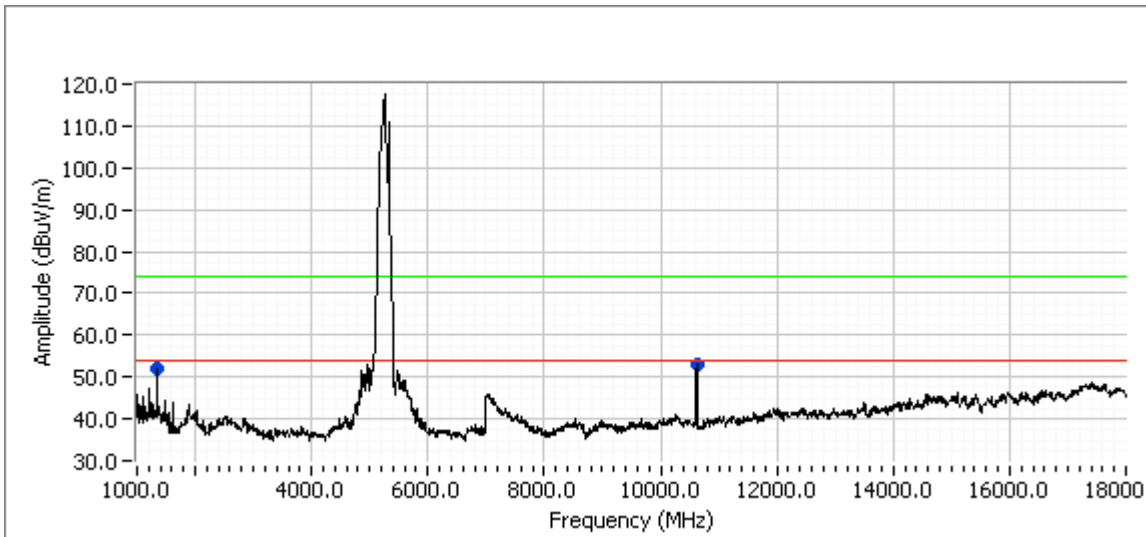

UUT Transmitting with 9 dBi Omni antenna MFB58009

Fund Freq MHz	Frequency MHz	Level dBµV/m	Pol v/h	15.209 / 15.247		Detector Pk/QP/Avg	Azimuth degrees	Height meters	Comments
				Limit	Margin				
5180	1098.82	45.1	V	54.0	-8.9	AVG	242	1.5	Restricted
5180	1098.82	60.1	V	74.0	-13.9	PK	242	1.5	Restricted
5180	5024.28	47.0	V	54.0	-7.0	AVG	111	1.0	Restricted
5180	5024.28	57.5	V	74.0	-16.5	PK	111	1.0	Restricted
5180	1319.93	53.1	V	54.0	-0.9	AVG	96	1.0	Restricted
5180	1319.93	56.0	V	74.0	-18.0	PK	96	1.0	Restricted
5180	10359.89	55.3	V	68.3	-13.0	PK	93	1.0	Non-restricted
5260	1095.33	46.8	V	54.0	-7.2	AVG	202	1.0	Restricted
5260	1095.33	60.0	V	74.0	-14.0	PK	202	1.0	Restricted
5260	1319.93	53.0	V	54.0	-1.1	AVG	250	1.0	Restricted
5260	1319.93	56.4	V	74.0	-17.6	PK	250	1.0	Restricted
5260	10518.70	60.7	V	68.3	-7.7	PK	138	2.2	Non-restricted
5320	1095.67	45.9	V	54.0	-8.1	AVG	154	1.0	Restricted
5320	1095.67	61.7	V	74.0	-12.4	PK	154	1.0	Restricted
5320	1319.92	53.9	V	54.0	-0.1	AVG	257	1.0	Restricted
5320	1319.92	56.2	V	74.0	-17.8	PK	257	1.0	Restricted
5320	4961.97	47.4	V	54.0	-6.7	AVG	267	1.0	Restricted
5320	4961.97	58.2	V	74.0	-15.8	PK	267	1.0	Restricted
5320	10639.15	43.9	V	54.0	-10.1	AVG	117	1.5	Restricted
5320	10639.15	55.0	V	74.0	-19.0	PK	117	1.5	Restricted

UUT Transmitting on 5180 MHz with 9 dBi Omni antenna MFB58009

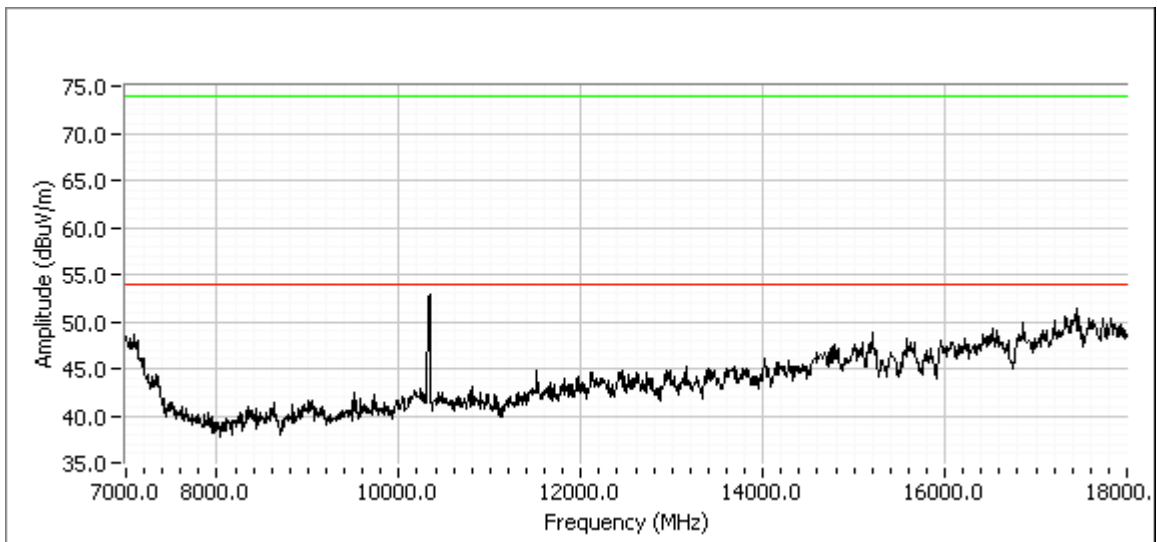
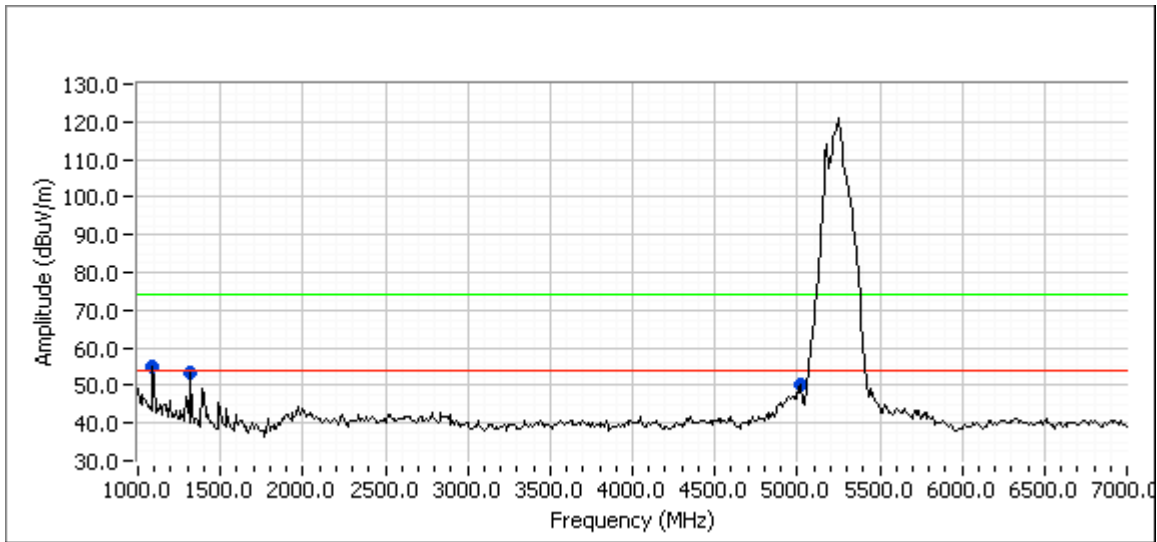

UUT Transmitting on 5260 MHz with 9 dBi Omni antenna MFB58009

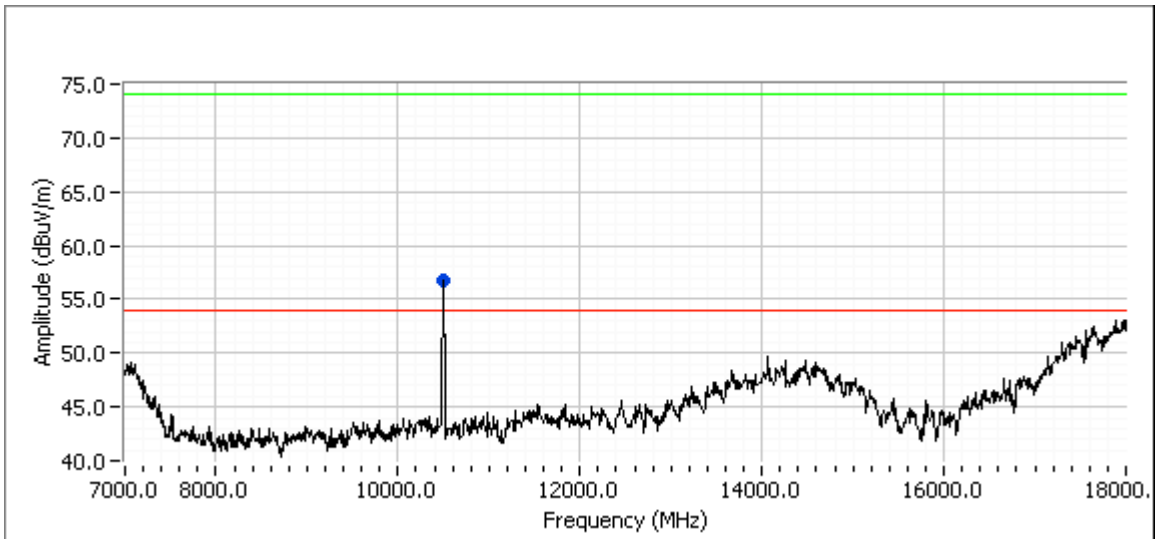
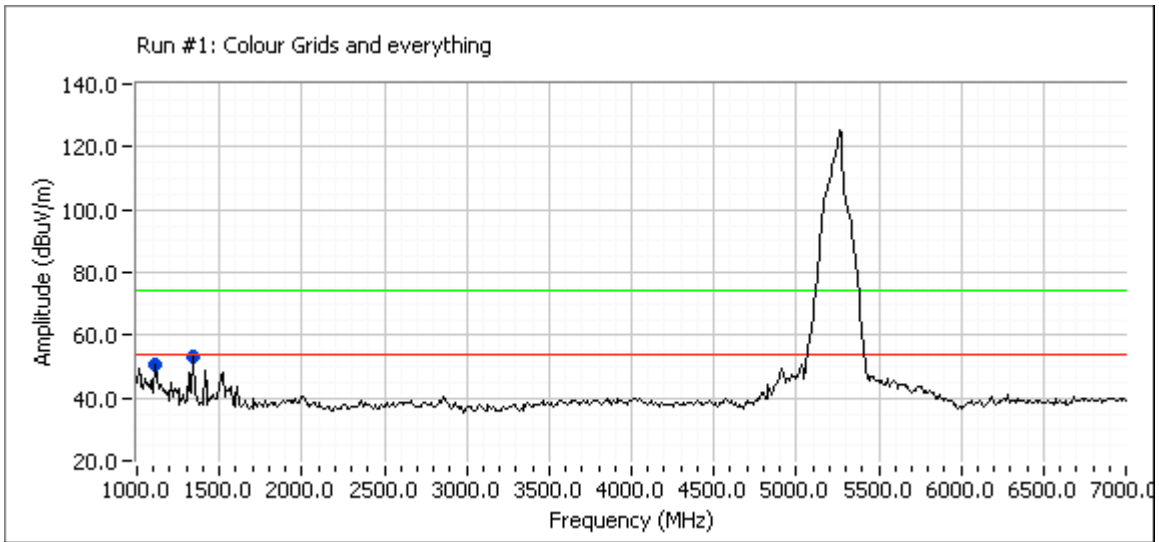

UUT Transmitting on 5320 MHz with 9 dBi Omni antenna MFB58009

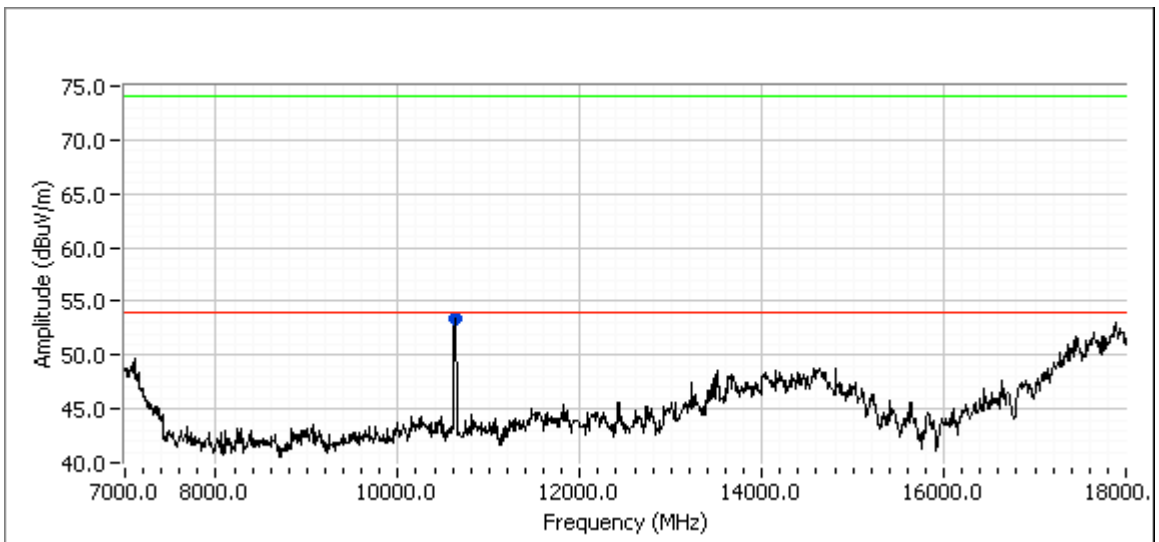
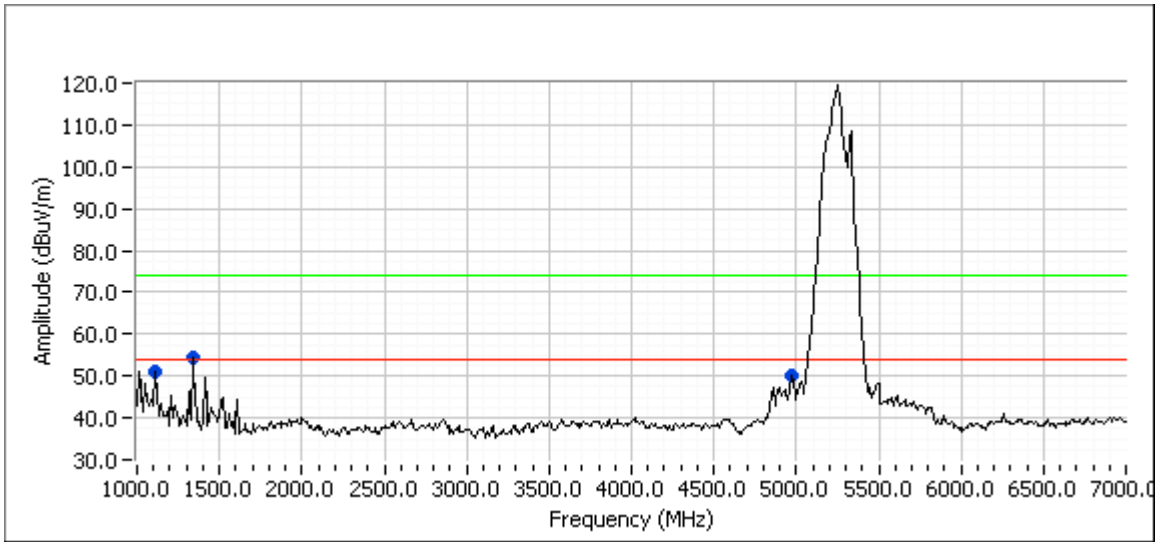

UUT Transmitting with 6 dBi Omni antenna S5153WPBX36RTN

Fund Freq	Frequency	Level	Pol	15.209 / 15.247		Detector	Azimuth	Height	Comments
MHz	MHz	dBmV/m	v/h	Limit	Margin	Pk/QP/Avg	degrees	meters	
5180	10348.06	51.4	V	68.3	-16.9	AVG	11	1.4	Non-Restricted
5180	1336.000	52.4	V	54.0	-1.6	AVG	199	1.0	Restricted
5180	1336.000	56.4	V	74.0	-17.6	PK	199	1.0	Restricted
5260	10516.83	58.5	V	68.3	-9.8	AVG	319	1.2	Non-restricted
5260	1319.79	52.8	V	54.0	-1.2	AVG	196	1.0	Restricted
5260	1319.79	54.8	V	74.0	-19.2	PK	196	1.0	Restricted
5320	1320.139	53.1	V	54.0	-0.9	AVG	193	1.0	Restricted
5320	1320.139	55.5	V	74.0	-18.5	PK	193	1.0	Restricted
5320	10636.64	51.4	V	54.0	-2.6	AVG	335	1.4	Restricted
5320	10636.64	63.3	V	74.0	-10.7	PK	335	1.4	Restricted

UUT Transmitting on 5180 with 6 dBi Omni antenna S5153WPBX36RTN

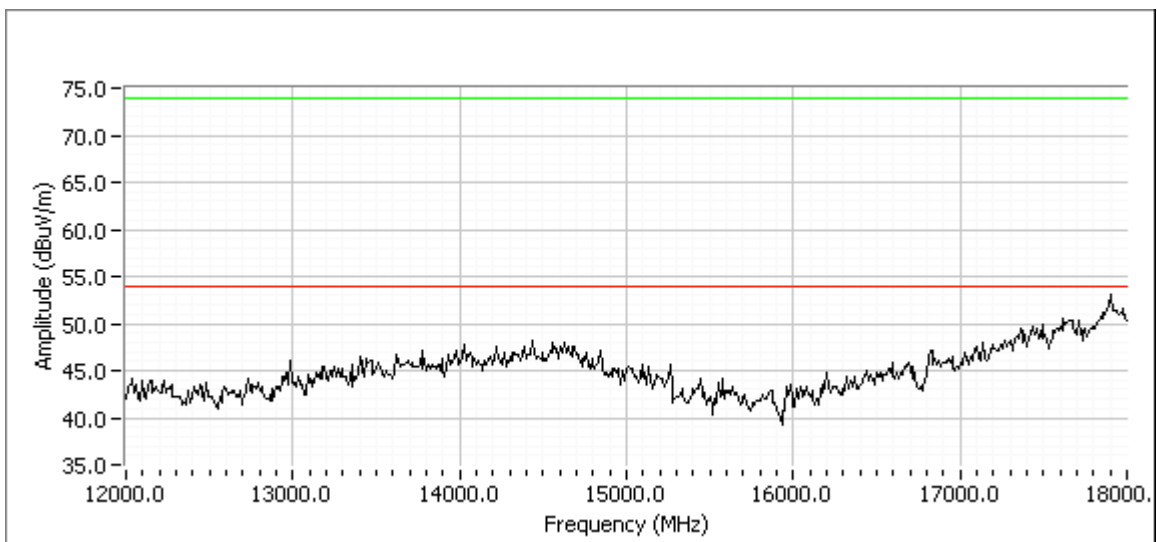
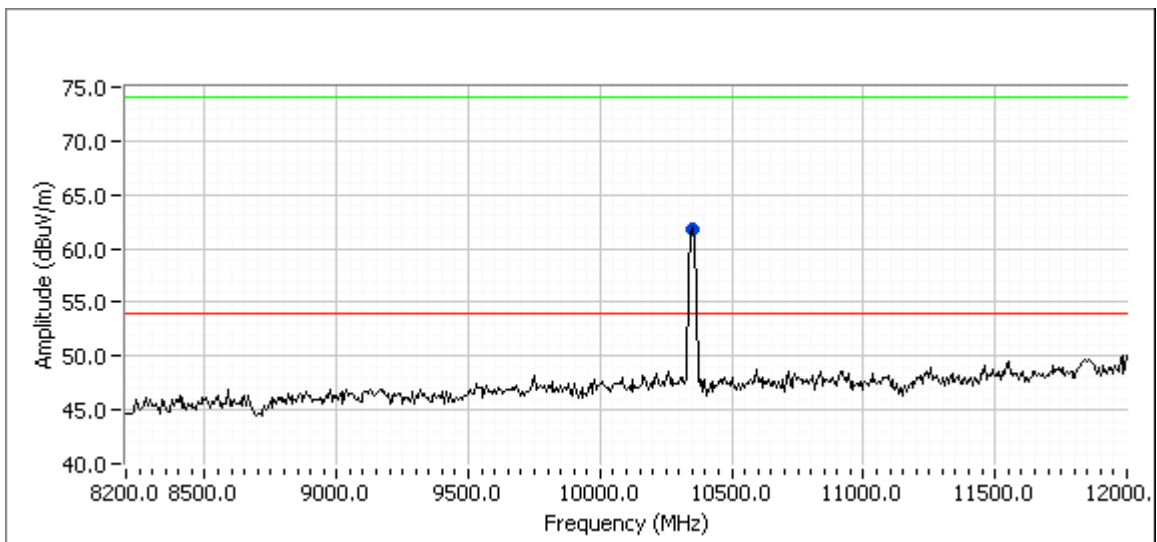
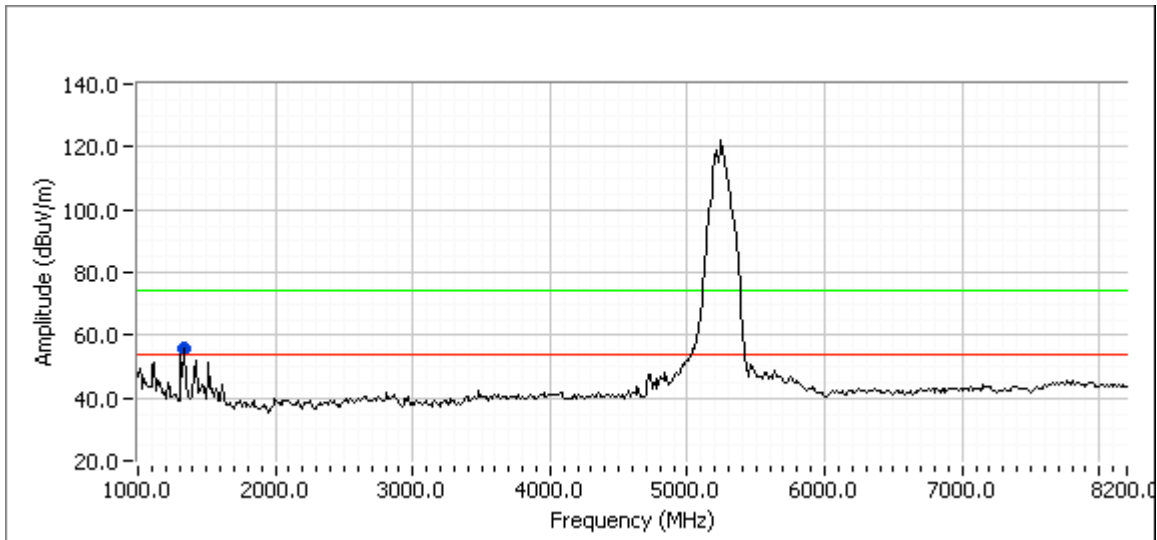

UUT Transmitting on 5260 with 6 dBi Omni antenna S5153WPBX36RTN

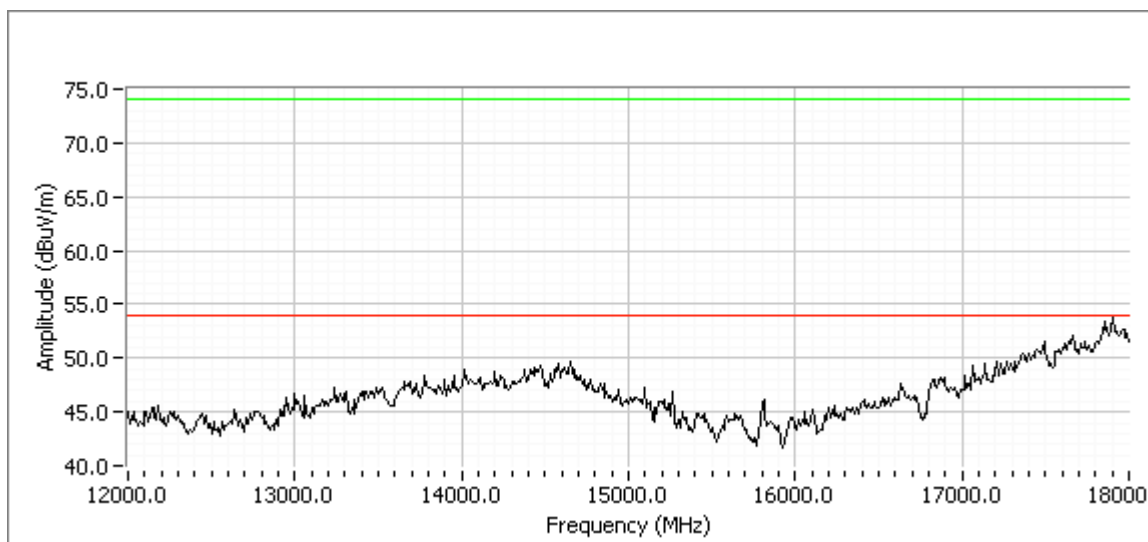
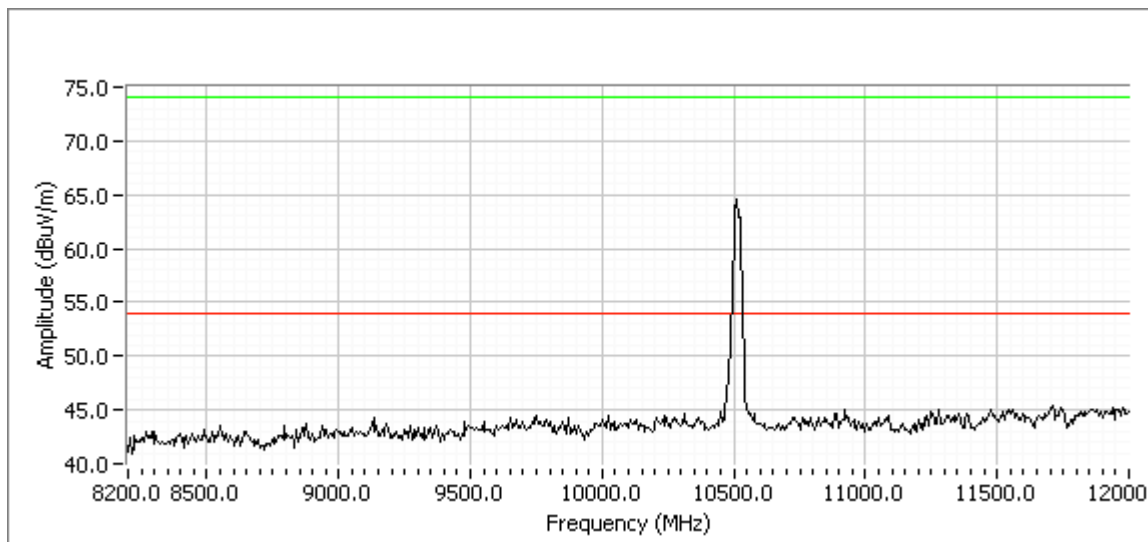
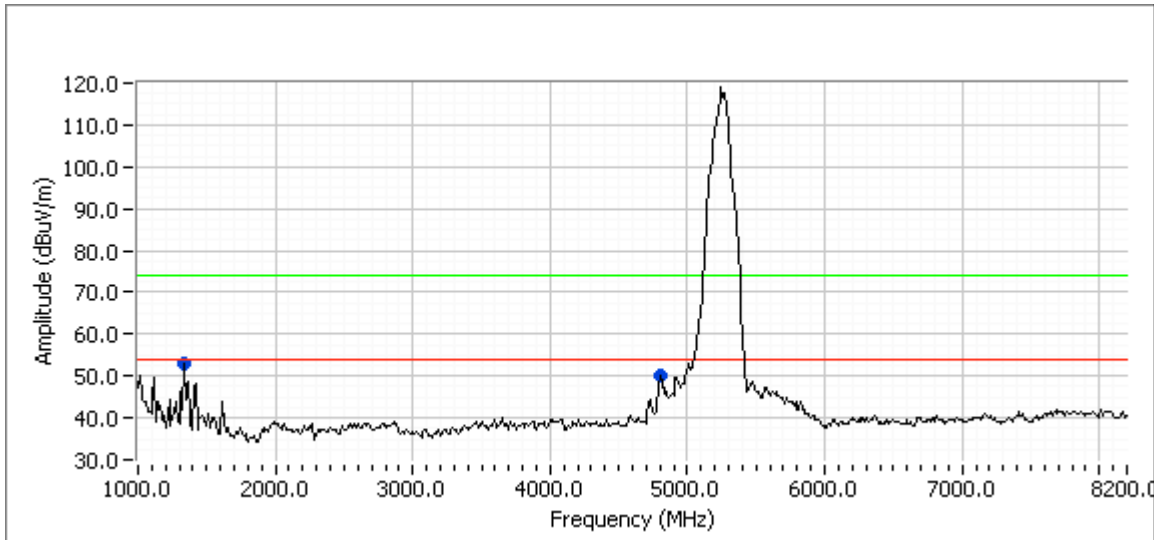

UUT Transmitting on 5320 with 6 dBi Omni antenna S5153WPBX36RTN

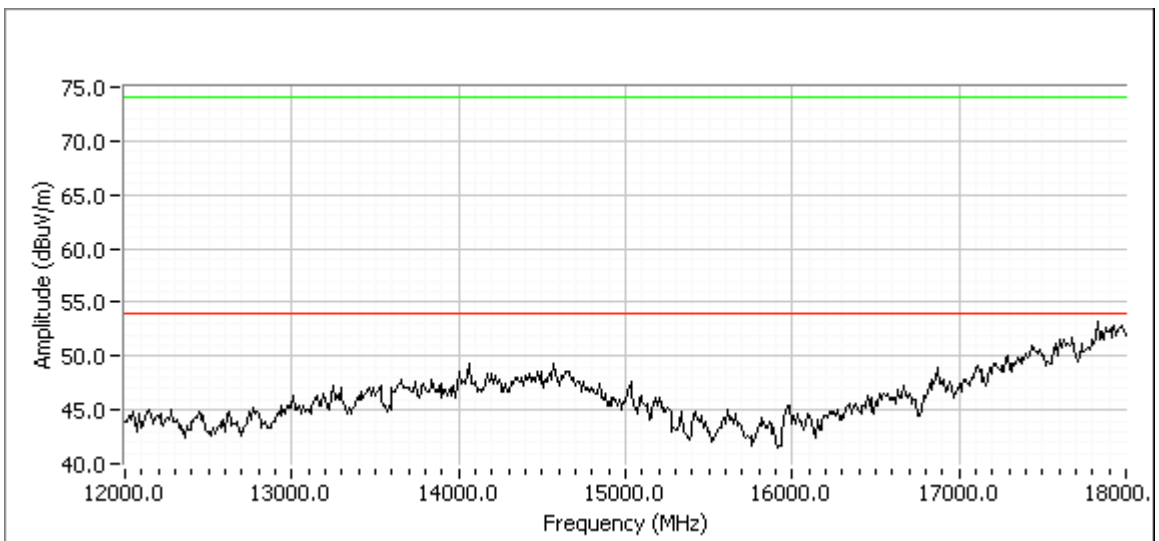
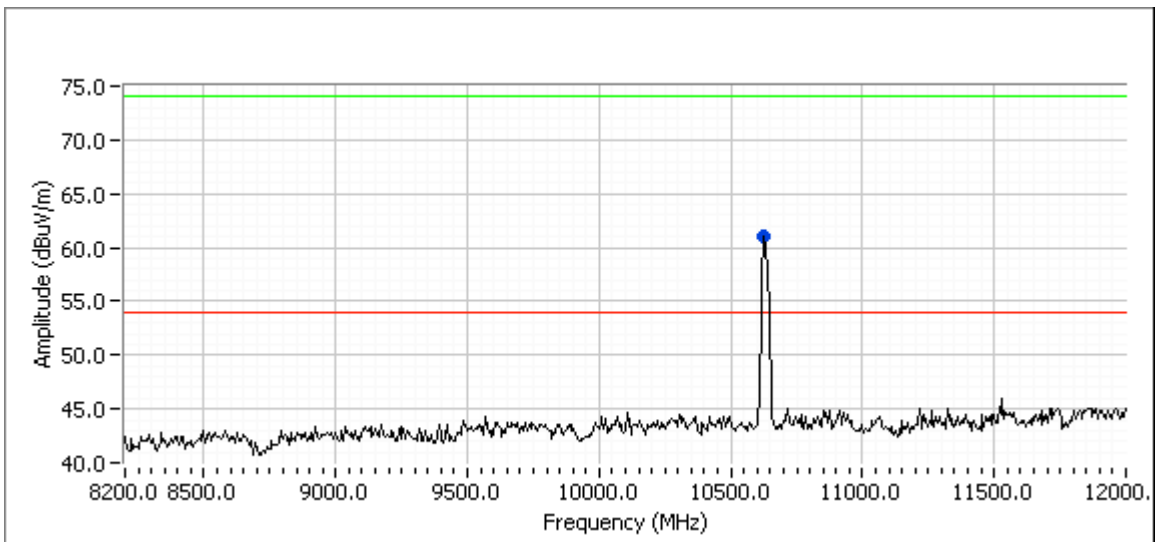
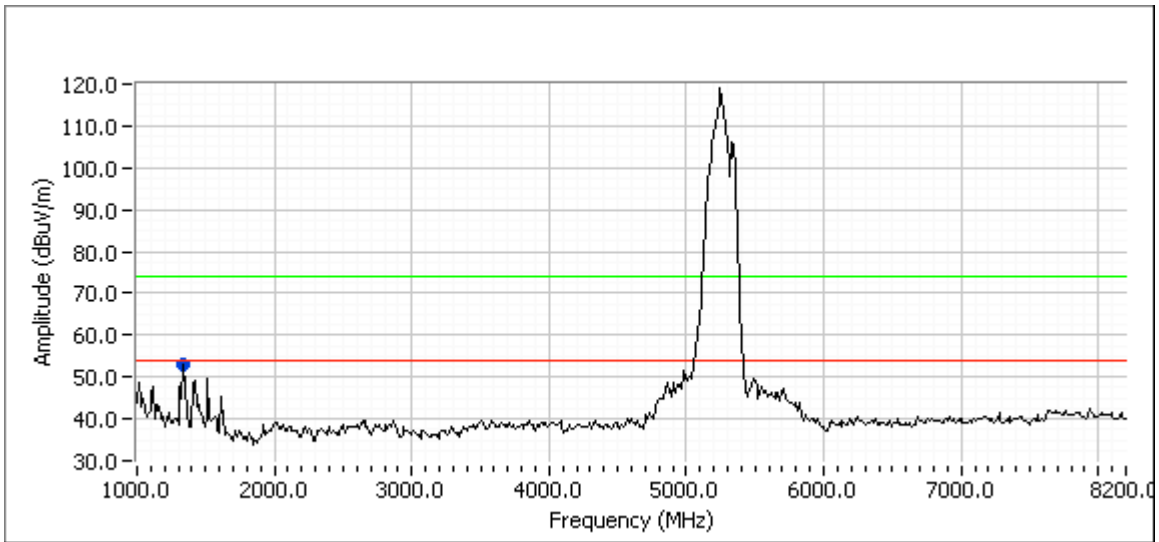

Radiated Emissions in Restricted Bands at the Band Edges.

Ending at 5.15 GHz and beginning at 5.35 GHz

Procedure

There are three steps to performing this test.

STEP 1: Make a radiated measurement of the fundamental signal with the UUT on the highest channel. This measurement is used using the peak and average RBW and VBW of 1MHz/1MHz and 1MHz/10Hz. This measured radiated level is then used as a reference and is referred to as the Fundamental Reference Measurement in the table below

STEP 2: Additional conducted measurements are made for Peak and Average -dBc values. The peak and average bandwidths are:

PEAK: RBW = 1 MHz VBW = 1 MHz

AVG: RBW = 1 MHz VBW = 10 Hz

These measurements determine a –dBc (delta dB) level between the fundamental reference level (in a 1 MHz BW) and the actual level at highest point within the restricted band. This dBc level is then subtracted from the associated (peak or avg) radiated field strength reference measurement made earlier.

STEP 3 A third measurement is made to determine the apparent drop in fundamental carrier power when the RBW is narrowed from 1MHz (in the reference measurement) to 100kHz (the actual specification BW) This is referred to below as the “BW Delta”. This correction factor is only allowed in the highest emission in the restricted band is less than 2 “standard bandwidths” from the edge of the restricted band.

This measurement is made at the highest emission within the restricted band and is the apparent drop in level when the RBW is narrowed from 1 MHz to 100 kHz.

This procedure is outline in FCC Public Notice DA 00-705, released on 30 March 2000 and is referred to as the “Marker-Delta Method”

The restricted bands that are of concern in the test are 4.5 – 5.15 GHz and 5.35 – 5.46 GHz because these restricted bands are adjacent to the operating bands of the AP.



The power setting of the access point during this test was as shown in the power settings table earlier in this report.

Radiated Emissions at the Band Edges Summary Table

Measured with the Cushcraft 14 dBi panel antenna S51514WP36RTN

802.11 A Band Edge (Restricted band @ 5.15GHz)												
Pol	Fundamental Radiated Ref Msmt		-dBc Delta Msmt		BW Delta Msmt		Radiated Level at Band Edge		Specification		Delta (dB below Limit)	
	Peak dbuv/m	Avg dbuv/m	Peak dBc	Avg dBc	Pk dB	Avg dB	Peak dBuv/m	Avg dBuv/m	Peak dBuv/m	Avg dBuv/m	Peak dBuv/m	Avg dBuv/m
Vert	113.9	104.9	42.83	42.59	9.03	9.33	62.04	52.98	74	54	11.96	1.02
Horz	97.8	88.3					45.94	36.38			28.06	17.62
802.11 A Band Edge (Restricted band @ 5.35GHz)												
Pol	Fundamental Radiated Ref Msmt		-dBc Delta Msmt		BW Delta Msmt		Radiated Level at Band Edge		Specification		Delta (dB below Limit)	
	Peak dbuv/m	Avg dbuv/m	Peak dBc	Avg dBc	Pk dB	Avg dB	Peak dBuv/m	Avg dBuv/m	Peak dBuv/m	Avg dBuv/m	Peak dBuv/m	Avg dBuv/m
Vert	119	110.8	50.51	49.82	8.24	8.78	60.251	52.2	74	54	13.75	1.80
Horz	101.3	92.4					42.551	33.8			31.45	20.20

Restricted band level (AVG) = AVG reference level - AVG delta dB - BW Delta dB
Restricted band level (Peak) = Peak reference level - Peak delta dB - BW Delta dB

Radiated Emissions Sample Calculations

Bandedge @ 5.15 GHz, AVG

$$104.9\text{dBuV/m} - 42.59\text{dB} - 9.33\text{dB} = 52.98$$

$$54 - 52.98 = 1.02 \text{ dB below limit}$$

5.15GHz Bandedge, -dBc (Peak)

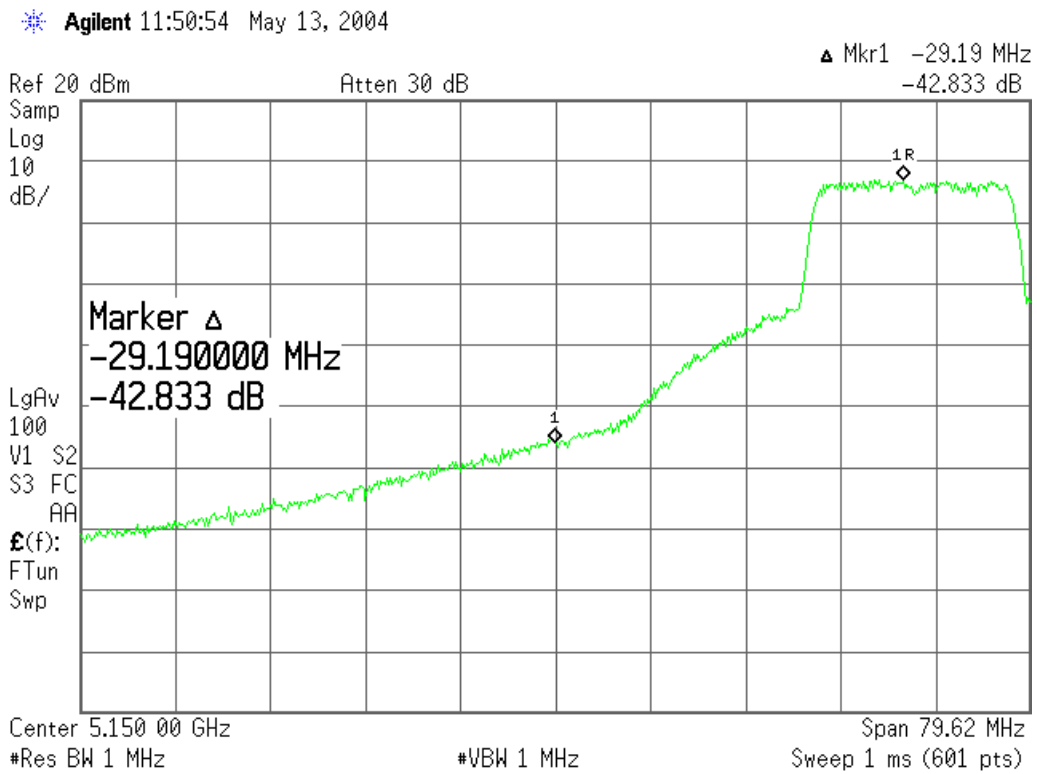

5.15GHz Bandedge, -dBc (Avg)

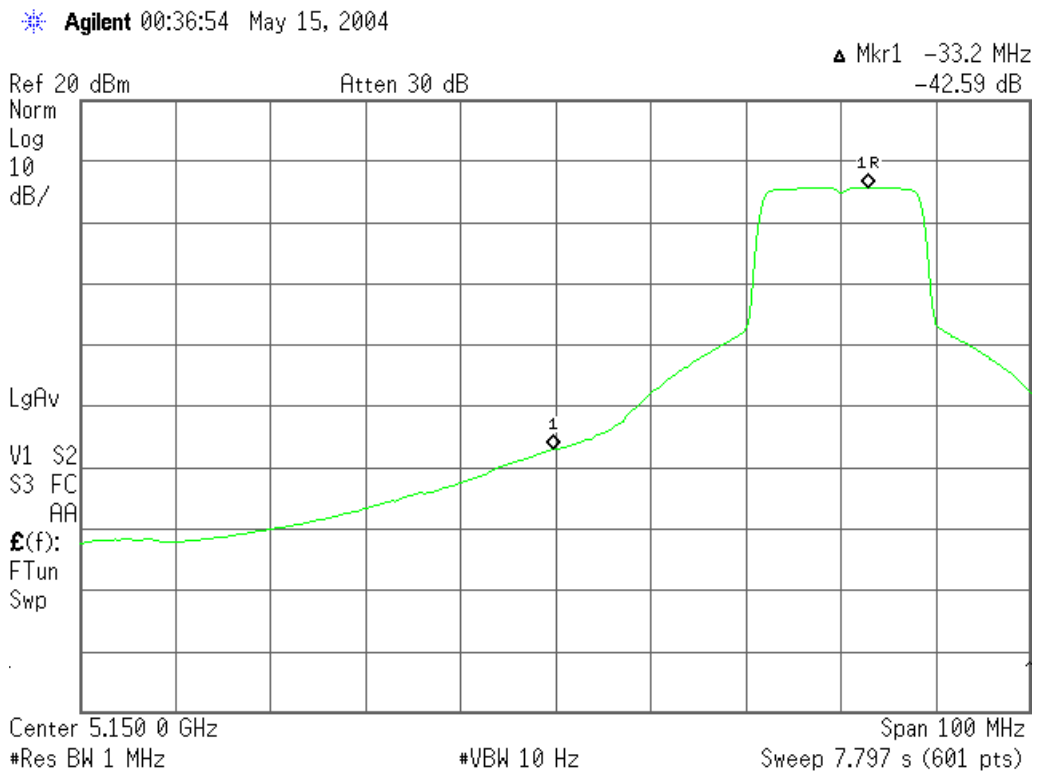

5.15GHz Bandedge, BW Delta (Peak)

Agilent 11:58:31 May 13, 2004

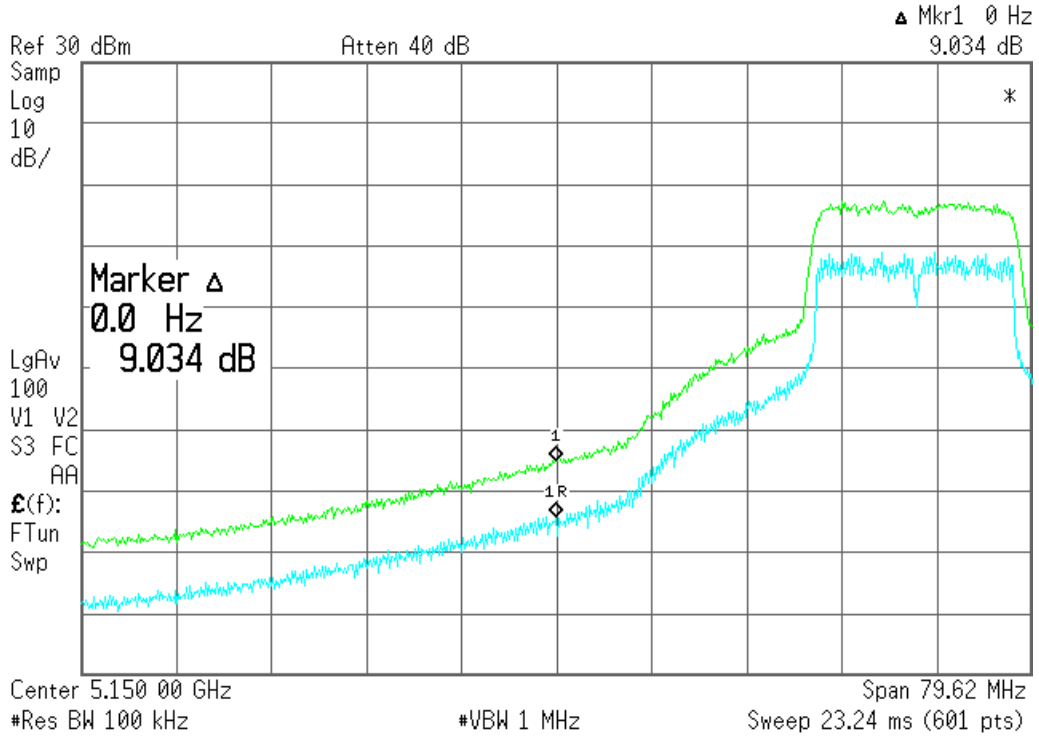

5.15GHz Bandedge, BW Delta (Avg)

Agilent 00:54:00 May 15, 2004

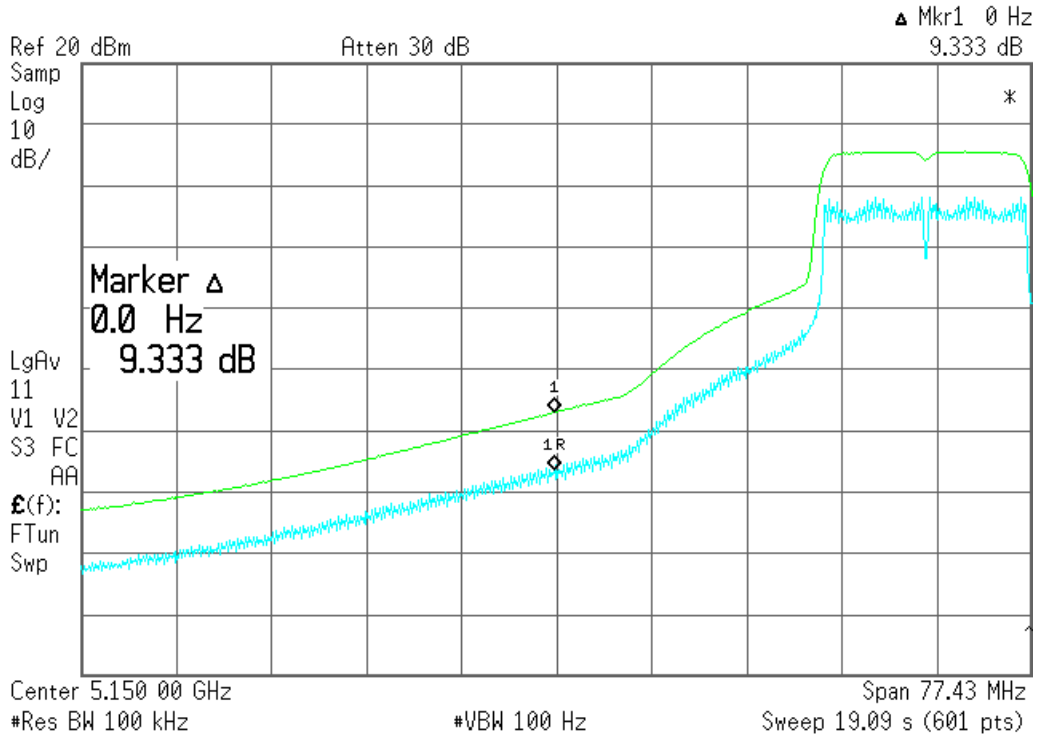

Agilent 20:33:41 Feb 21, 2005

Mkr1 34.40 MHz
-50.572 dB

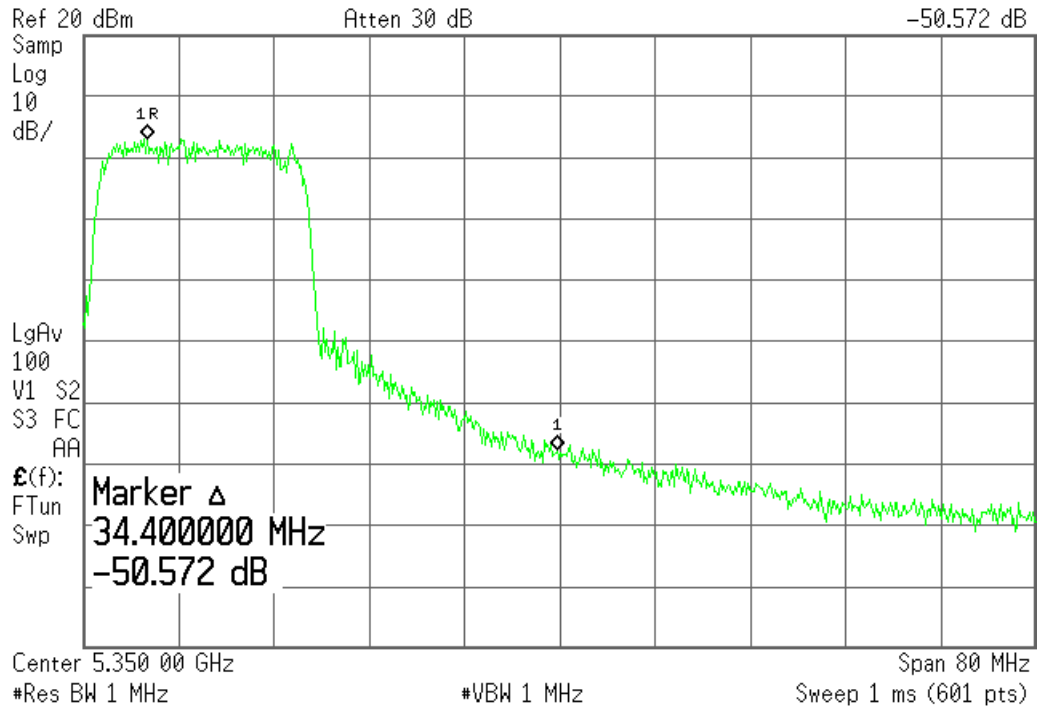

5.35GHz Bandedge, -dBc (Peak)

Agilent 20:35:23 Feb 21, 2005

Mkr1 35.20 MHz
-49.82 dB

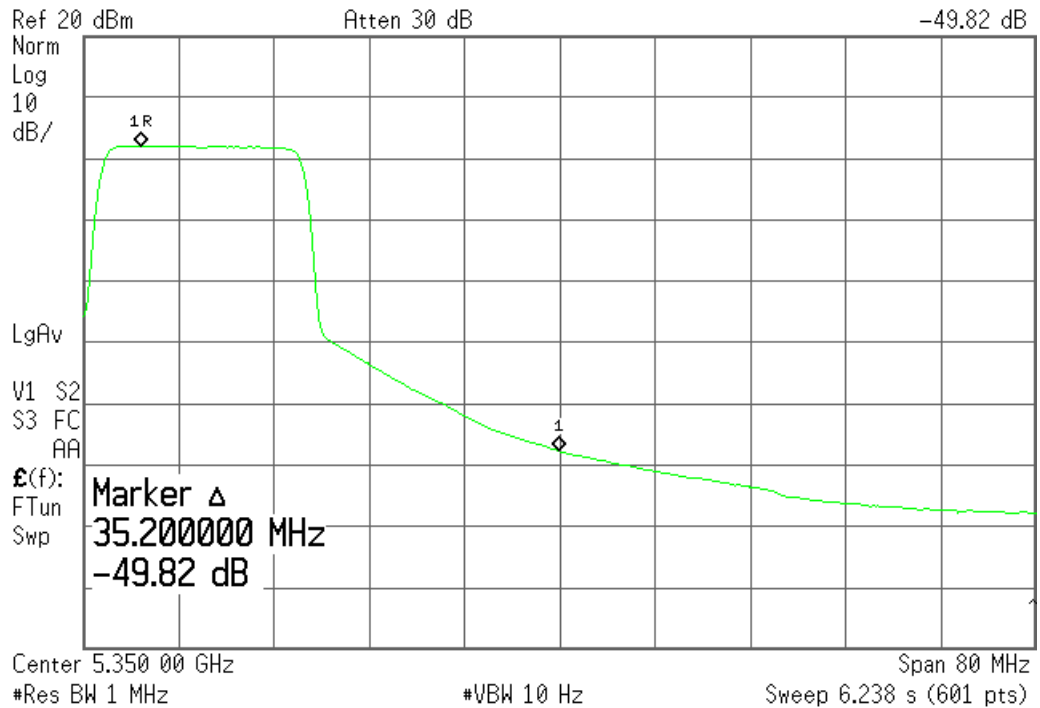

5.35GHz Bandedge, -dBc (Avg)

Agilent 20:40:36 Feb 21, 2005

Mkr1 0 Hz
8.237 dB

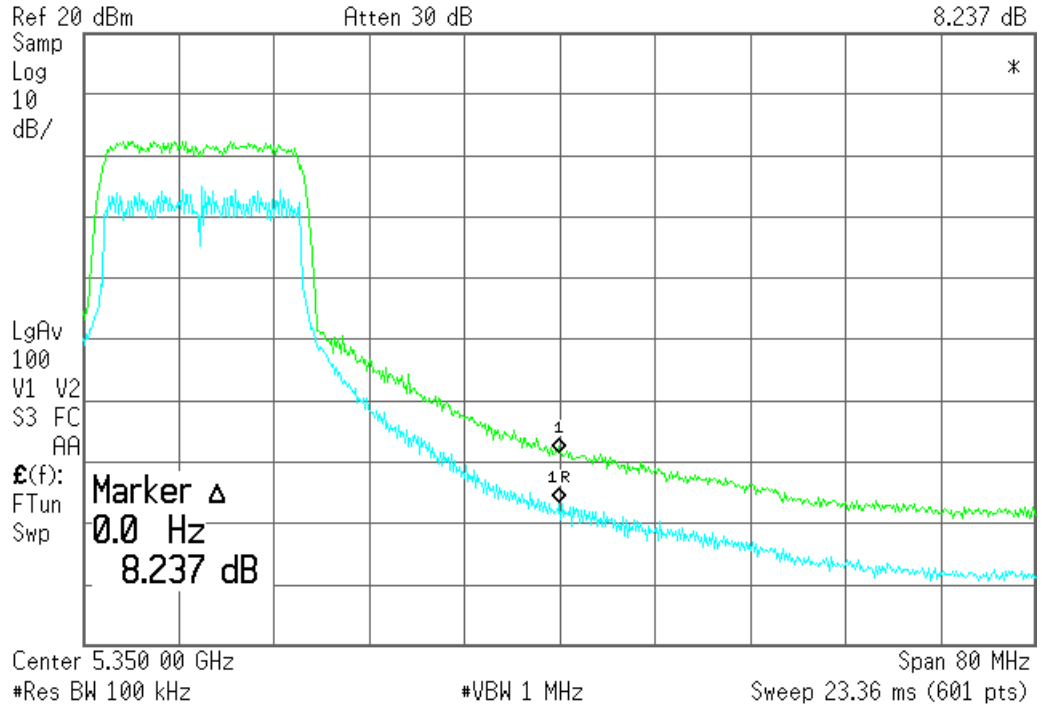

5.35GHz Bandedge, BW Delta (Peak)

Agilent 20:37:57 Feb 21, 2005

Mkr1 0 Hz
8.78 dB

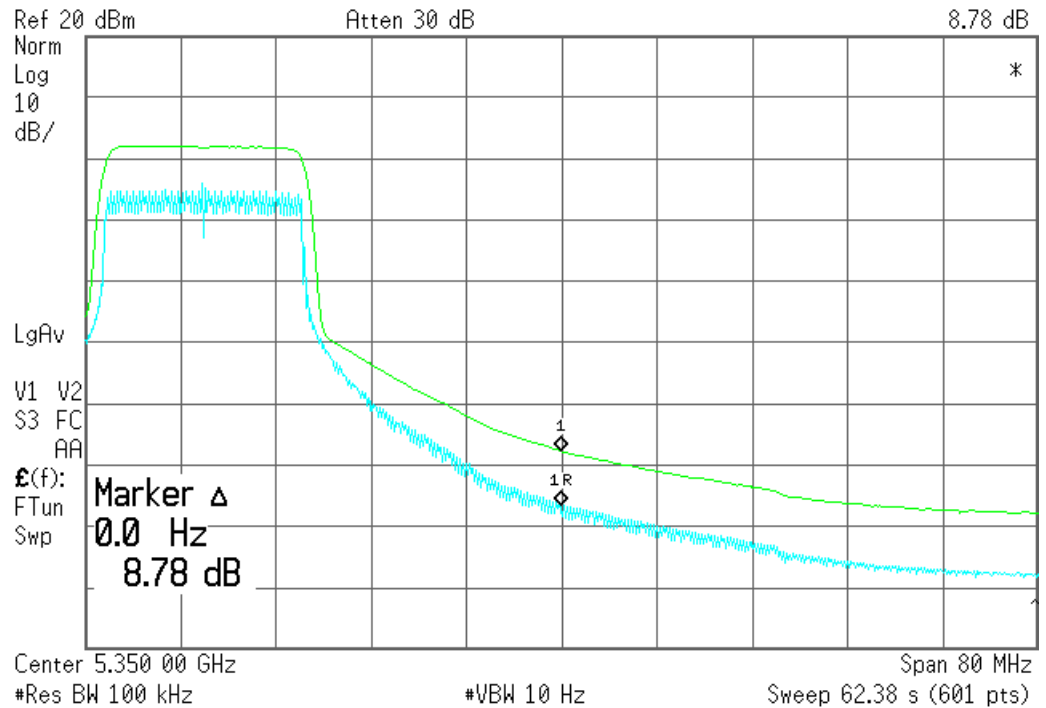

5.35GHz Bandedge, BW Delta (Avg)