



4655 Great America Parkway  
Santa Clara, California 95054

**FCC Part 15.247  
Class II Permissive Change Application  
Industrie Canada RSS210 Reassessment**

**EMI Test Report  
and  
Technical Documentation  
on  
Nortel 802.11 Access Point.  
Model: 2230**

**FCC ID: [RVW2230](#)**

**IC ID: [332R-2230](#)**

**Prepared by:**

David Waitt  
202 Calvert Drive #217  
Cupertino, Ca. 95014  
[david@waitt.us](mailto:david@waitt.us)  
(408) 832 7053

**Table of Contents**

<b>Section</b>	<b>Page</b>
General Information .....	3
Detailed Product Information .....	4
Background from initial certification application test report .....	4
Class II Permissive Change Request Information .....	4
Test Results Summary .....	6
ANTENNA: S2403BHN36RTN .....	6
ANTENNA: S2409PN36RTN .....	6
Test Facilities .....	7
Equipment Lists .....	8
Test Methods .....	9
RF Transmit Power from initial certification report for reference .....	9
ISM Radiated Emissions in Restricted bands .....	10
Specifications .....	10
Procedure: .....	10
Results: Antenna S2403BHN36RTN .....	12
UUT transmitting 802.11B on low channel: 2412 MHz (S2403BHN36RTN ) .....	12
UUT transmitting 802.11B on mid channel: 2437 MHz (S2403BHN36RTN ) .....	13
UUT transmitting 802.11B on high channel: 2462 MHz (S2403BHN36RTN ) .....	14
UUT transmitting 802.11G on low channel: 2412 MHz (S2403BHN36RTN ) .....	15
UUT transmitting 802.11G on mid channel: 2437 MHz (S2403BHN36RTN ) .....	16
UUT transmitting 802.11G on high channel: 2462 MHz (S2403BHN36RTN ) .....	17
Results: Antenna S2409PN36RTN: .....	18
UUT transmitting 802.11B on low Channel: 2412 MHz (S2409PN36RTN) .....	18
UUT transmitting 802.11B on mid Channel: 2437 MHz (S2409PN36RTN) .....	19
UUT transmitting 802.11B on high Channel: 2462 MHz (S2409PN36RTN) .....	20
UUT transmitting 802.11G on low Channel: 2412 MHz (S2409PN36RTN) .....	21
UUT transmitting 802.11G on mid Channel: 2437 MHz (S2409PN36RTN) .....	22
UUT transmitting 802.11G on high Channel: 2462 MHz (S2409PN36RTN) .....	23
ISM Radiated Emissions in Restricted bands (2.4 GHz Band Edges) .....	24
FCC Specifications: .....	24
Procedure: .....	24
Results: Antenna: S2403BHN36RTN .....	25
Results: Antenna: S2409PN36RTN .....	26
802.11 B Restricted Band at 2390MHz Plots .....	27
802.11 B Restricted Band at 2483.5 MHz Plots .....	29
802.11 G Restricted Band at 2390MHz Plots .....	31
802.11 G Restricted Band at 2483.5 MHz Plots .....	33

## General Information

**Unit(s) Under Test:** Nortel 802.11 Access Point (AP)  
**Model:** 2230

**Product Description:** IEEE 802.11 A/B/G Access point

**FCC ID:** **RVW2230**  
**IC ID** **332R-2230**

**Tested For:** Nortel Networks  
4655 Great America Parkway  
Santa Clara, CA 95054, USA

**Tested At:** Elliott Laboratories  
684 West Maude Ave  
Sunnyvale, CA 94086

**Tested By:** Juan Martinez, Sr. Test Engineer, Elliott Laboratories  
Yalda Noor, Test Engineer, Elliott Laboratories  
David Waitt, (Independent Consultant for Nortel)

**Test Specifications:** FCC CFR 47, Part 15.247, 2.4 GHz DSSS

**Test Date:** Nov / Dec 2004

**Requested Certification:** Class 2 Permissive change

**Date of Initial Grant:** 26 March 2004

## Detailed Product Information

### Background from initial certification application test report

The Nortel radio is an IEEE 802.11 A/B/G Access point (AP) intended to be professionally installed and configured in corporate and industrial environments.

The device utilizes a mini PCI module manufactured by an outside vendor. The manufacturer of the module has received FCC modular approval. The Nortel access point uses the module with a higher gain antenna than was certified for use with the module, therefore Nortel is applying for their own grant.

The modules incorporated into the access point radio are IEEE802.11 A/B/G mini PCI modules. However the functionality of the module is determined by the mini PCI slot in which the module is inserted. (See internal photos) There are two slots within the access point, 802.11 A and 802.11 B/G. In the case of the B/G access point, the module is inserted into the B/G slot, therefore the A/B/G module functions ONLY as 802.11 B/G. The user cannot modify this selectivity behavior via the configuration software.

### Class II Permissive Change Request Information

Nortel wishes to authorize the use of additional external antennas with the access point. The specific antennas are outlined below, and these antennas will be offered to the users of the access point by Nortel. However, additional antennas may be used providing that they are of the same type of antenna (omni) and equal or lower gain than the antennas below.

All of the antennas tested are complaint with 15.203 since the access point utilizes R-TNC external antenna connectors.

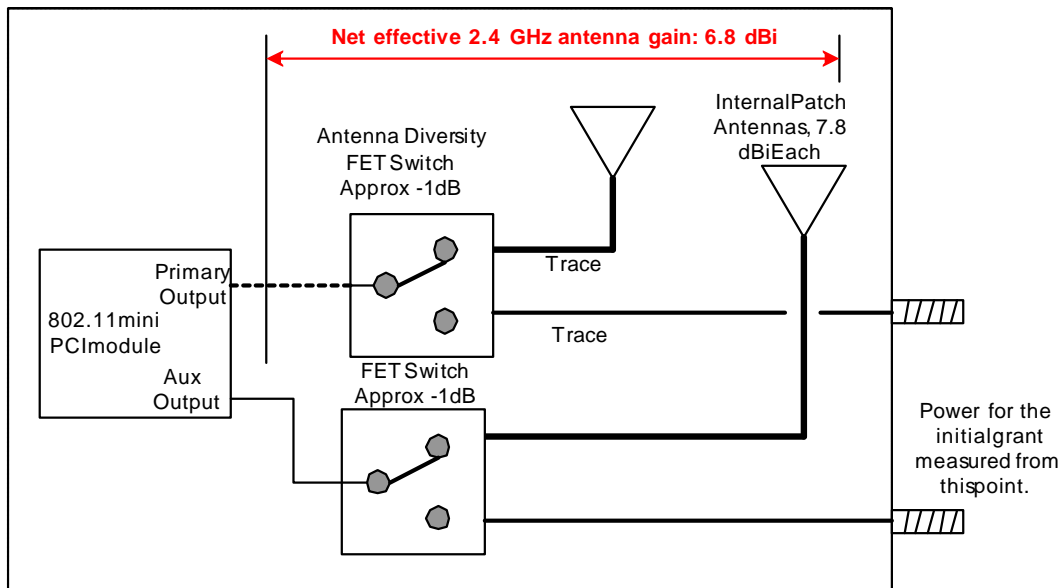

**2.4 GHz RF Block Diagram (Internal / External Antenna Version)**

The table below summarizes the additional antennas to be used with the access point. Test data was recorded for two of the three antennas. Data was not gathered for the RTN2400MRA antennas since it is of the same type as the S2403BHN36RTN antenna and is of lower gain.

Note that the S2409PN36RTN is the only antenna with higher gain than the access point was originally certified with

<b>Cushcraft Part Number</b>	<b>Freq Range (GHz)</b>	<b>Gain(dBi)</b>	<b>Antenna Type</b>	<b>Description</b>	<b>Tested</b>
<b>S2403BHN36RTN</b>	2.4-2.5	5.15	Dipole	Colinear Omni, 2 co-located dipoles	YES
<b>RTN2400MRA</b>	2.4-2.5	2.0	Dipole	Omni-directional dipole antenna	NO
<b>S2409PN36RTN</b>	2.4-2.5	8.5	Panel	Directional Panel antenna	YES

The following tests were conducted for the S2403BHN36RTN and S2409PN36RTN antennas

<b>TEST</b>	<b>Performed (Y / N)</b>	<b>Justification</b>
Radiated emissions in Restricted bands / Out of band emissions	Y	It is reasonable to assume that the radiated emissions performance of the AP may be affected by utilizing an different antenna
Power Spectral Density	N	The power spectral density specification is NOT in terms of EIRP, therefore, as long as the transmit power is unchanged, the PSD should not be affected by a different antenna
RF Transmit power	N	While the transmit power was verified for the radiated emissions testing, to ensure it is the same as the original grant, it is not presented in this report
Bandwidth	N	There is no reason to expect that the use of a different antenna would affect the bandwidth of the signal
Line Conducted Emissions	N	There is no reason to expect that the use of a different antenna would affect the AC line conducted emissions of the access point

## Test Results Summary

A brief results summary of all the in this report is below.

### ANTENNA: S2403BHN36RTN

<b>Part 15 Paragraph</b>	<b>RSS-210 Paragraph</b>	<b>Test</b>	<b>Results</b>
15.247(c)	6.2.2(o)(a) 4	Out of Band Spurious Emissions	-2.3 dB in Spec (3168.117MHz xmit @ 2412G)
15.205	6.3( c )	Radiated Emissions in Restricted bands	- 2.2 dB in spec min (1706.9 MHz xmit @ 2437G )

### ANTENNA: S2409PN36RTN

<b>Part 15 Paragraph</b>	<b>RSS-210 Paragraph</b>	<b>Test</b>	<b>Results</b>
15.247(c)	6.2.2(o)(a) 4	Out of Band Spurious Emissions	-16.2 dB in Spec (9846.31 MHz xmit @2462G)
15.205	6.3( c )	Radiated Emissions in Restricted bands	.31 dB in spec min 2483.5 MHz @ 2462 B

## Test Facilities

Many of the certification tests were performed at:

Elliott Labs  
684 West Maude Ave  
Sunnyvale, CA 94086

The tests performed at Elliott include:

- All radiated emissions tests required in FCC Part 15.205 for 2.4 GHz.
- Out of band emissions (Conducted) (for 2.4 GHz)

### General:

Final 802.11 B radiated test measurements were taken at Elliott Laboratories Semi Anechoic chamber #5

The test site contains separate areas for radiated and conducted emissions testing. Pursuant to section 2.948 of the Rules, construction, calibration, and equipment data has been filed with the Commission.

The FCC recommends that ambient noise at the test site be at least 6 dB below the allowable limits. Ambient levels are below this requirement with the exception of predictable local TV, radio, and mobile communications traffic. The test site contains separate areas for radiated and conducted emissions testing. Considerable engineering effort has been expended to ensure that the facilities conform to all pertinent FCC requirements.

### OATS:

The FCC has determined that radiation measurements made in a shielded enclosure are not suitable for determining levels of radiated emissions. Radiated emissions are performed in an open field environment. The test site is maintained free of conductive objects within the CISPR defined elliptical area incorporated in ANSI C63.4 Guidelines.

### Antenna, Antenna Mast and Turntable

The Horn antennas that are used to measure radiated emissions above 1000MHz are mounted on a non-conductive antenna mast equipped with a motor drive to vary the antenna height.

ANSI C63.4 specifies that the test height above the ground plane shall be 80cm unless the equipment is intended to be floor mounted. During the radiated emissions tests the equipment is positioned on a motorized turntable in conformance with the ANSI requirement.

## Equipment Lists

### Instrument Calibration

All test equipment is regularly checked to ensure that performance is maintained in accordance with the manufacturer's specifications. All antennas are calibrated at regular intervals with respect to tuned half-wave dipoles. An exhibit of this report contains the list of test equipment used and calibration information.

The following test equipment was used to perform the testing

### Elliott Test Equipment

<u>Manufacturer</u>	<u>Description</u>	<u>Model #</u>	<u>Asset #</u>	<u>Cal Due</u>
Hewlett Packard	Microwave Preamplifier, 1-26.5GHz	8449B	263	08-Jan-05
Hewlett Packard	EMC Spectrum Analyzer 9KHz-26.5GHz, non programmable	8563E	284	15-Mar-05
ETS-Lindgren	Horn Antenna, D. Ridge 1-18GHz	3117	1662	30-Mar-05



## Test Methods

The tests are performed at a low, middle and high channel of the applicable band. The typical frequencies used for the Part15.247 2.4 GHz tests are listed in the table to the right. Unless otherwise noted, all testing was performed on these channels / frequencies

ISM 802.11 B		
2400 - 2483.5 MHz		
Channel	Freq( MHz )	
Low	Chan 1	2412
Mid	Chan 6	2437
High	Chan 11	2462

All of the testing for this permissive change request was conducted at the same power level as specified in the original grant for each given frequency and modulation type (B or G)

### RF Transmit Power from initial certification report for reference

*The power levels below reflect the power into the antenna, and are adjusted down by 1 dB from what was actually measured to account for the 1 dB loss of the FET switch. The power measurements listed in the tables above are also applicable for the power into the external antennas if used with the product*

Freq (MHz)	802.11 B			802.11 G			Spec (dBm)	Min Delta (dB)
	Power into antenna (dBm)	Power into antenna (mW)	Xmit Power (dBm EIRP)	Power into antenna (dBm)	Power into antenna (mW)	Xmit Power (dBm EIRP)		
2412	18.1	64.57	25.9	18.1	64.57	25.9	30	11.9
2437	20.4	109.65	28.2	20.4	109.65	28.2	30	9.6
2462	15.9	38.90	23.7	14.1	25.70	21.9	30	14.1

## ISM Radiated Emissions in Restricted bands

Specifications: FCC Part 15: Paragraph 15.247(c)

### Procedure:

This test was conducted on a 3-meter semi anechoic chamber at Elliott Laboratories. The unit was placed on a rotating wooden table 80cm above the ground plane. A Horn antenna was secured to a mast 3 meters away. The unit was tested at each of the Low, Mid and High channels. The UUT was running in the diagnostic mode and set to transmit CW at maximum power on each of the channels. The test equipment was configured as shown below.

The harmonics of the fundamental that fell within restricted bands (up to the tenth) were measured (See table 1 below). A high pass filter prior to the pre-amplifier was required to prevent the large signal level of the fundamental frequency from overloading the front end of the spectrum analyzer and creating harmonics within the analyzer.

The EUT was rotated 360 degrees and the height of the antenna adjusted from 1 to 4 meters above the ground plane to determine the maximum level of the emission. The level of the harmonic emission was measured in two modes, "Peak" and "Average".

The spectrum analyzer reading was entered into a spreadsheet where correction factors (antenna factor, cable loss, pre-amplifier gain, HPF loss...) were then applied by Elliott Lab's Software to obtain a final corrected measurement.

This procedure was repeated for the low (Ch 1), mid (Ch 6) and high (Ch 11) channels within the 2400-2483.5MHz band.

The band up to 25 GHz was examined, however there were no spurious emissions noted above approximately 18 GHz.

The table below indicates the harmonics that fall within restricted bands.

FUND	Harmonic (MHz)								
	2	3	4	5	6	7	8	9	10
2412	4824	7236	9648	12060	14472	16884	19296	21708	24120
2437	4874	7311	9748	12185	14622	17059	19496	21933	24370
2462	4924	7386	9848	12310	14772	17234	19696	22158	24620

### 15.205 Harmonic test tables

**NOTE:** RED indicates a harmonic that falls within a restricted band and is subject to 15.205. The harmonics in black are NOT in restricted bands and are subject to 15.209

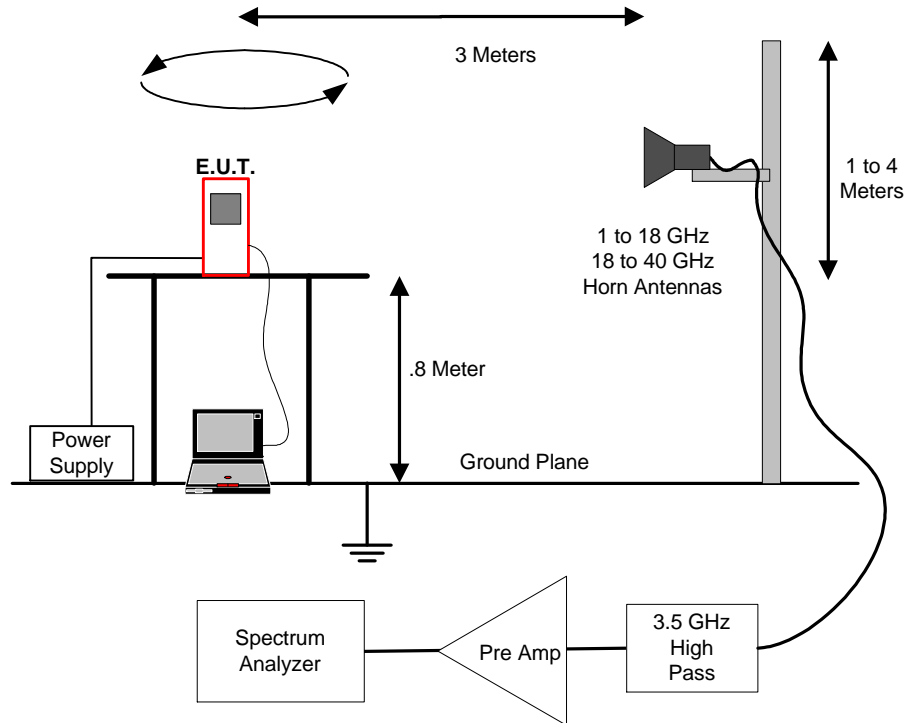

Radiated Emissions in Restricted Bands Test Setup

Support Equipment				
Description	Model number	FCC ID or SN	Manufacturer	Power Cable
Laptop	IBM Thinkpad	-	IBM	Laptop PS
Test Software	Atheros Radio Test		Atheros	
48VDC AC adapter	Generic		Generic	Standard Twin lead DC wire

Test Conditions			
Temperature	23 C	Humidity:	39%
ATM pressure	1020 mBar	Grounding:	None
Tested By	Yalda Noor Elliott Labs	Date of Test:	Nov / Dec 2004
Test Reference	FCC Part 15.205 IC Paragraph RSS210, 6.2.3 ( c )		
Setup Method	ANSI C63.4		
Tested Range	1 GHz to 24 GHz		
Test Voltage	120 VAC / 60 Hz		
Modifications	No modifications were made to the unit		

**NOTES:** For emissions in restricted bands, the limit of 15.209 was used. For all other emissions, the limit was set 20dB below the level of the fundamental. No emission detected above 15GHz.

Restricted Band Peak Measurements: Resolution and Video BW: 1 MHz  
 Restricted Band Average Measurements: Resolution BW: 1MHz and Video BW: 10 Hz.  
 All other measurements, RBW = 1MHz and VBW = 3MHz, video averaging on (100 samples).

**Results: Antenna S2403BHN36RTN**

UUT transmitting 802.11B on low channel: 2412 MHz (S2403BHN36RTN )

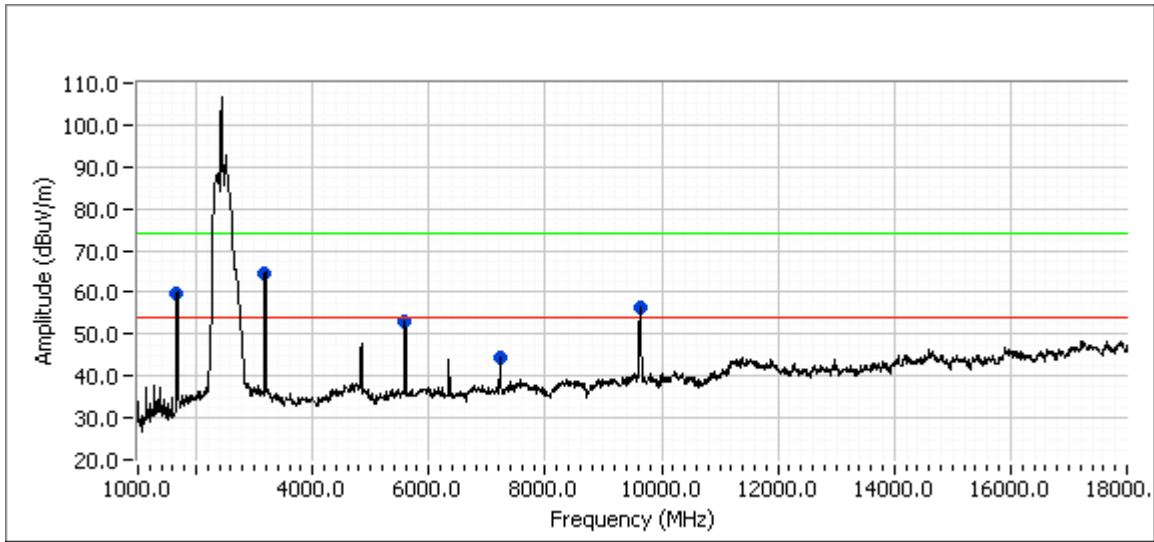

Frequency	Level	Pol	15.209 / 15.247		Detector	Azimuth	Height	Comments
MHz	dBμV/m	v/h	Limit	Margin	Pk/QP/Avg	degrees	meters	
2412.00	107.4	V	-	-	AVG	129	1.0	CH#1 Fundamental
2412.00	113.7	V	-	-	PK	129	1.0	CH#1 Fundamental
2412.00	89.6	H	-	-	AVG	308	1.0	CH#1 Fundamental
2412.00	95.9	H	-	-	PK	308	1.0	CH#1 Fundamental
1661.552	58.1	V	83.7	-25.6	PK	20	1.0	Non-restricted
1662.467	31.1	V	54.0	-22.9	AVG	312	2.5	Restricted
1662.467	40.3	V	74.0	-33.7	PK	312	2.5	Restricted
1661.636	37.6	H	54.0	-16.4	AVG	338	1.0	Restricted
1661.636	45.3	H	74.0	-28.7	PK	338	1.0	Restricted
3168.012	65.2	V	83.7	-18.5	PK	357	2.0	Non-restricted
5581.168	55.7	V	83.7	-28.0	PK	250	1.0	Non-restricted
9647.965	59.6	H	66.9	-7.3	PK	256	1.5	Non-restricted
7238.559	47.0	V	83.7	-36.7	PK	298	1.0	Non-restricted

*No spurious emissions noted above 18 GHz*

UUT transmitting 802.11B on mid channel: 2437 MHz (S2403BHN36RTN )

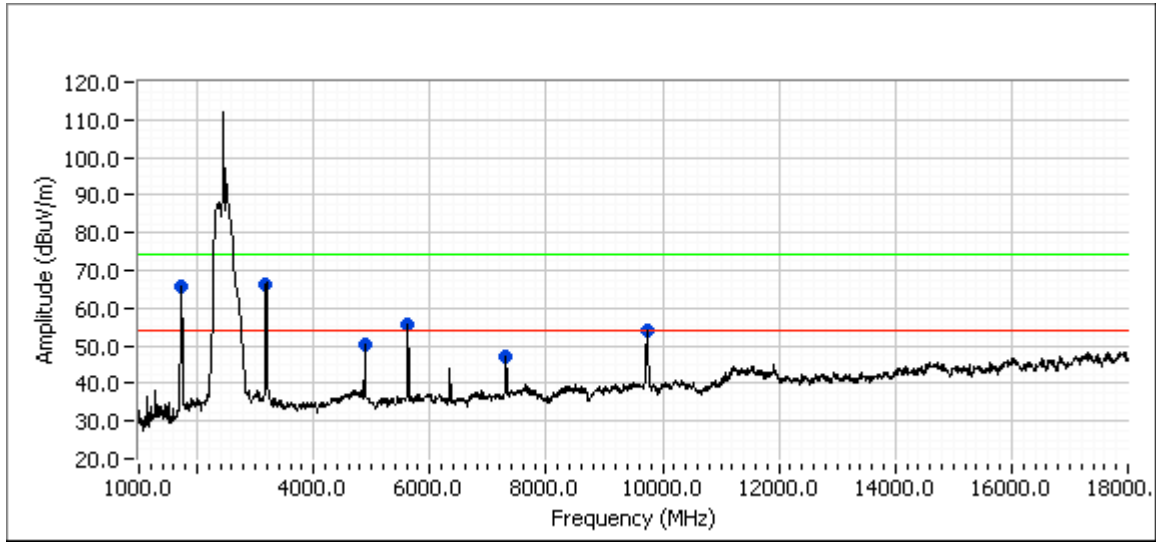

Frequency	Level	Pol	15.209 / 15.247		Detector	Azimuth	Height	Comments
MHz	dBμV/m	v/h	Limit	Margin	Pk/QP/Avg	degrees	meters	
2437.00	109.1	V	-	-	AVG	91	1.0	Ch#6 Fundamental
2437.00	114.3	V	-	-	PK	91	1.0	Ch#6 Fundamental
2437.00	93.4	H	-	-	AVG	307	1.0	Ch#6 Fundamental
2437.00	98.3	H	-	-	PK	307	1.0	Ch#6 Fundamental
1718.575	37.0	V	54.0	-17.0	AVG	347	1.5	Restricted
1718.575	43.1	V	74.0	-30.9	PK	347	1.5	Restricted
3168.027	65.5	V	84.3	-18.8	PK	176	1.0	Non-restricted
4868.684	43.3	V	54.0	-10.7	AVG	149	1.0	Restricted
4868.684	50.6	V	74.0	-23.4	PK	149	1.0	Restricted
5605.661	59.1	V	84.3	-25.2	PK	149	1.0	Non-restricted
9747.319	54.7	V	84.3	-29.7	PK	109	1.0	Non-restricted
7312.202	42.1	V	54.0	-11.9	AVG	306	1.5	Restricted
7312.202	51.6	V	74.0	-22.4	PK	306	1.5	Restricted

No spurious emissions noted above 18 GHz

UUT transmitting 802.11B on high channel: 2462 MHz (S2403BHN36RTN )

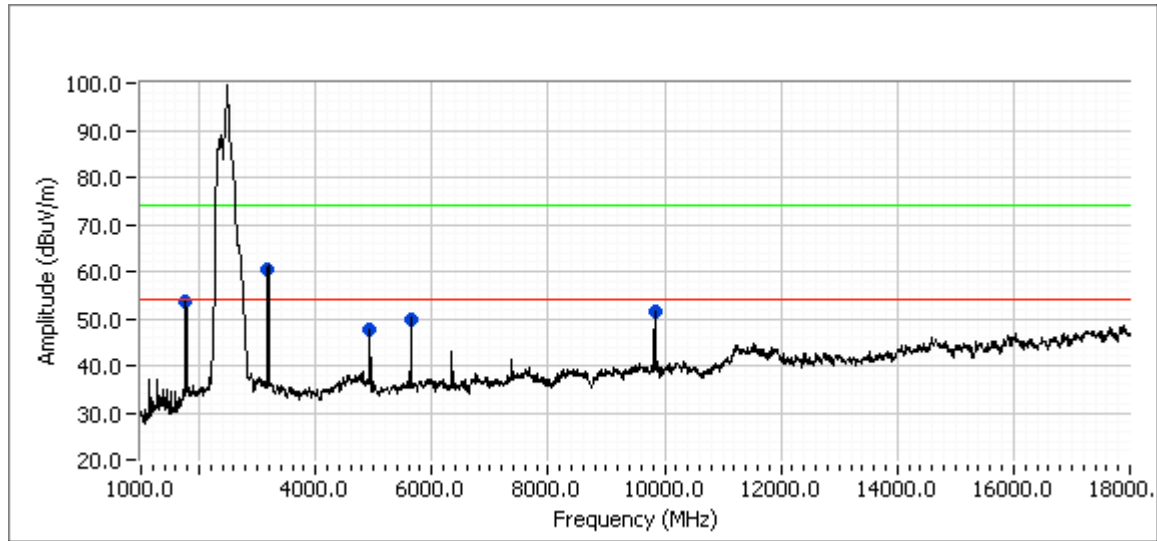

Frequency	Level	Pol	15.209 / 15.247		Detector	Azimuth	Height	Comments
MHz	dBμV/m	v/h	Limit	Margin	Pk/QP/Avg	degrees	meters	
2462.00	103.3	V	-	-	AVG	123	1.0	Ch#11 Fundamental
2462.00	109.3	V	-	-	PK	123	1.0	Ch#11 Fundamental
2462.00	90.7	H	-	-	AVG	324	1.5	Ch#11 Fundamental
2462.00	97.4	H	-	-	PK	324	1.5	Ch#11 Fundamental
1756.200	57.3	V	79.3	-22.0	PK	20	1.0	Non-restricted
3167.997	61.0	V	79.3	-18.4	PK	68	2.0	Non-restricted
4918.775	39.7	V	54.0	-14.3	AVG	57	2.0	Restricted
4918.775	47.8	V	74.0	-26.2	PK	57	2.0	Restricted
5631.487	53.1	V	79.3	-26.2	PK	262	1.0	Non-restricted
9847.932	55.8	V	79.3	-23.5	PK	111	1.0	Non-restricted

No spurious emissions noted above 18 GHz

UUT transmitting 802.11G on low channel: 2412 MHz (S2403BHN36RTN)

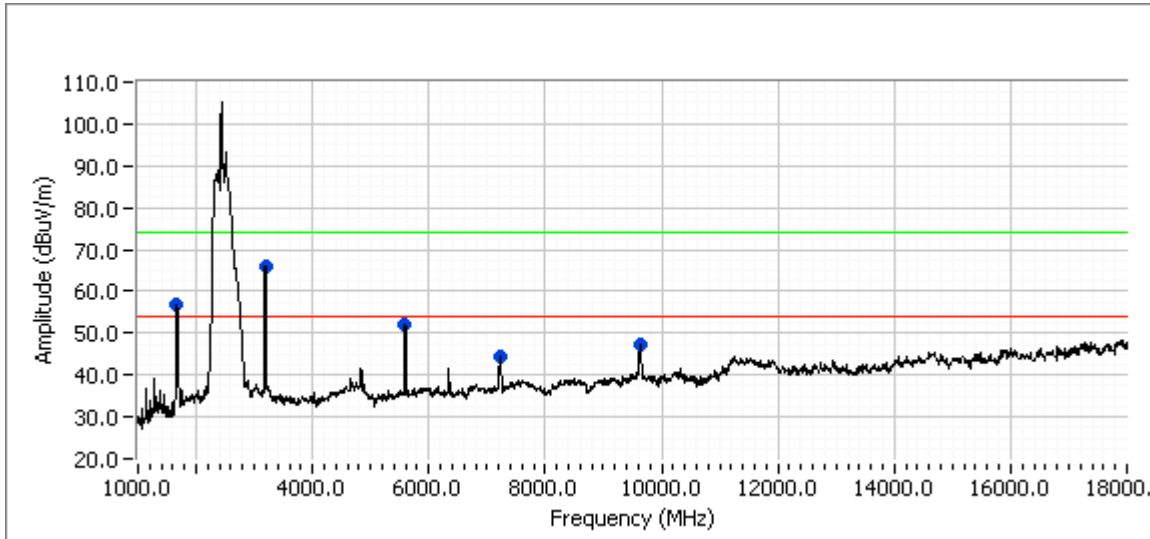

Frequency	Level	Pol	15.209 / 15.247		Detector	Azimuth	Height	Comments
MHz	dB $\mu$ V/m	v/h	Limit	Margin	Pk/OP/Avg	degrees	meters	
2412.00	105.3	V	-	-	AVG	130	1.0	CH#1 Fundamental
2412.00	115.2	V	-	-	PK	130	1.0	CH#1 Fundamental
2412.00	84.6	H	-	-	AVG	307	1.0	CH#1 Fundamental
2412.00	93.7	H	-	-	PK	307	1.0	CH#1 Fundamental
9645.070	53.7	H	63.7	-10.0	PK	298	1.5	Non-restricted
7232.643	52.5	V	85.2	-32.7	PK	310	1.5	Non-restricted
1657.171	56.3	V	85.2	-28.9	PK	4	1.5	Non-restricted
3168.117	61.4	H	63.7	-2.3	PK	358	2.0	Non-restricted
5579.760	58.4	V	85.2	-26.8	PK	247	1.0	Non-restricted

No spurious emissions noted above 18 GHz

UUT transmitting 802.11G on mid channel: 2437 MHz (S2403BHN36RTN )

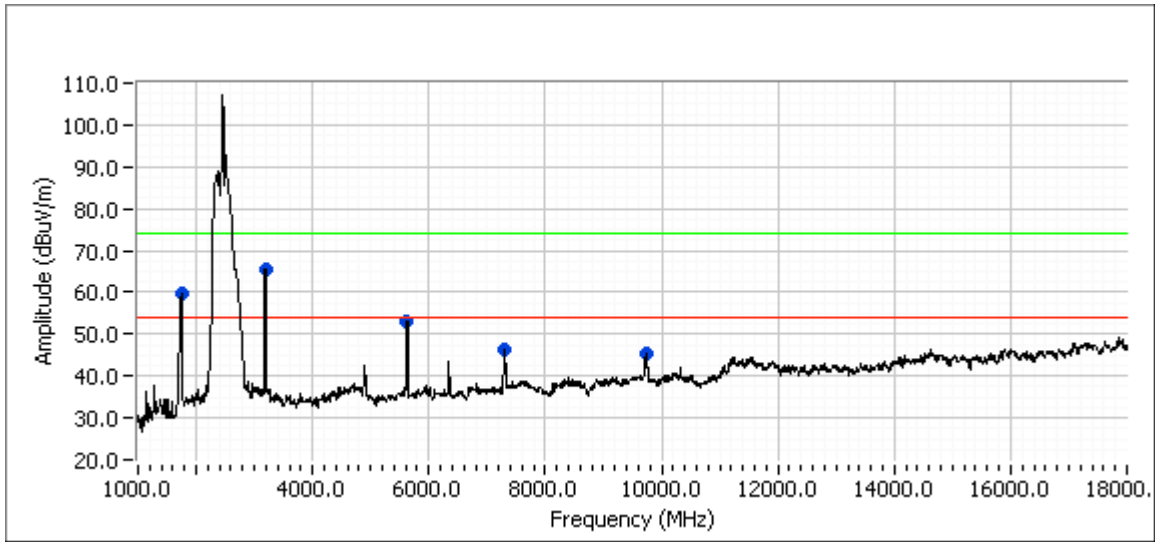

Frequency	Level	Pol	15.209 / 15.247		Detector	Azimuth	Height	Comments
MHz	dBμV/m	v/h	Limit	Margin	Pk/OP/Avg	degrees	meters	
2437.00	102.2	V	-	-	AVG	92	2.0	Ch#6 Fundamental
2437.00	111.8	V	-	-	PK	92	2.0	Ch#6 Fundamental
2437.00	85.5	H	-	-	AVG	305	1.0	Ch#6 Fundamental
2437.00	94.8	H	-	-	PK	305	1.0	Ch#6 Fundamental
5606.481	60.0	V	81.8	-21.8	PK	137	1.0	Non-restricted
3168.047	68.1	V	81.8	-13.7	PK	357	2.0	Non-restricted
1706.900	51.8	V	54.0	-2.2	AVG	172	1.0	Restricted
1706.900	62.6	V	74.0	-11.4	PK	172	1.0	Restricted
7314.914	37.1	H	54.0	-17.0	AVG	235	1.0	Restricted
7314.914	48.7	H	74.0	-25.4	PK	235	1.0	Restricted
9745.257	51.2	V	81.8	-30.6	PK	107	1.0	Non-restricted

No spurious emissions noted above 18 GHz



UUT transmitting 802.11G on high channel: 2462 MHz (S2403BHN36RTN )

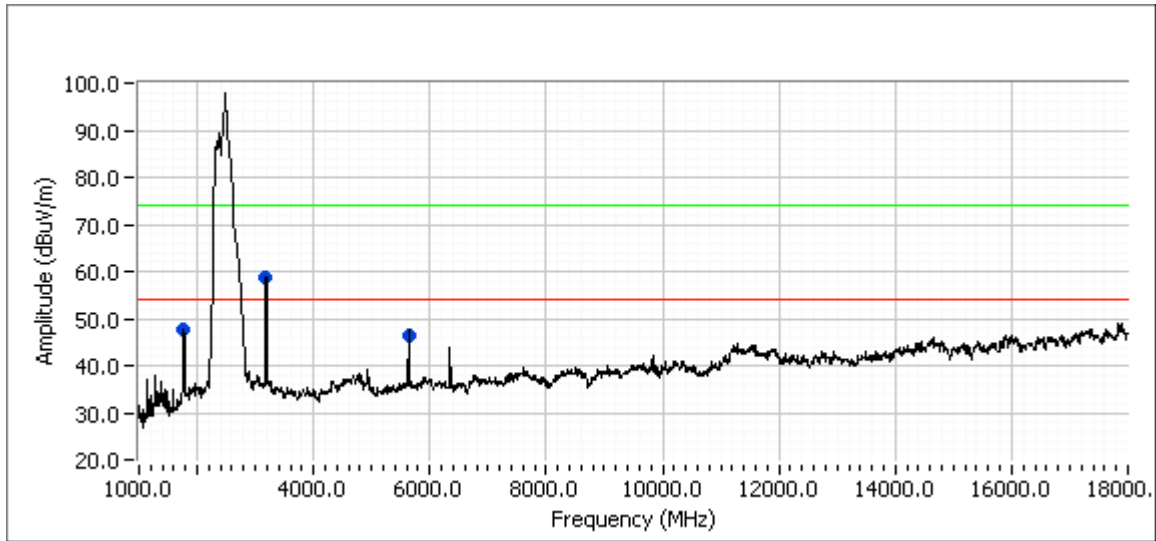

Frequency	Level	Pol	15.209 / 15.247		Detector	Azimuth	Height	Comments
MHz	dB $\mu$ V/m	v/h	Limit	Margin	Pk/QP/Avg	degrees	meters	
2462.00	99.8	V	-	-	AVG	125	1.0	Ch#11 Fundamental
2462.00	109.6	V	-	-	PK	125	1.0	Ch#11 Fundamental
2462.00	87.0	H	-	-	AVG	327	1.6	Ch#11 Fundamental
2462.00	96.5	H	-	-	PK	327	1.6	Ch#11 Fundamental
3168.027	62.9	V	79.6	-16.7	PK	46	2.0	Non-restricted
1755.697	55.1	V	79.6	-24.5	PK	308	1.0	Non-restricted
5632.628	56.5	V	79.6	-23.1	PK	135	1.0	Non-restricted

*No spurious emissions noted above 18 GHz*

**Results: Antenna S2409PN36RTN:**  
 UUT transmitting 802.11B on low Channel: 2412 MHz (S2409PN36RTN)

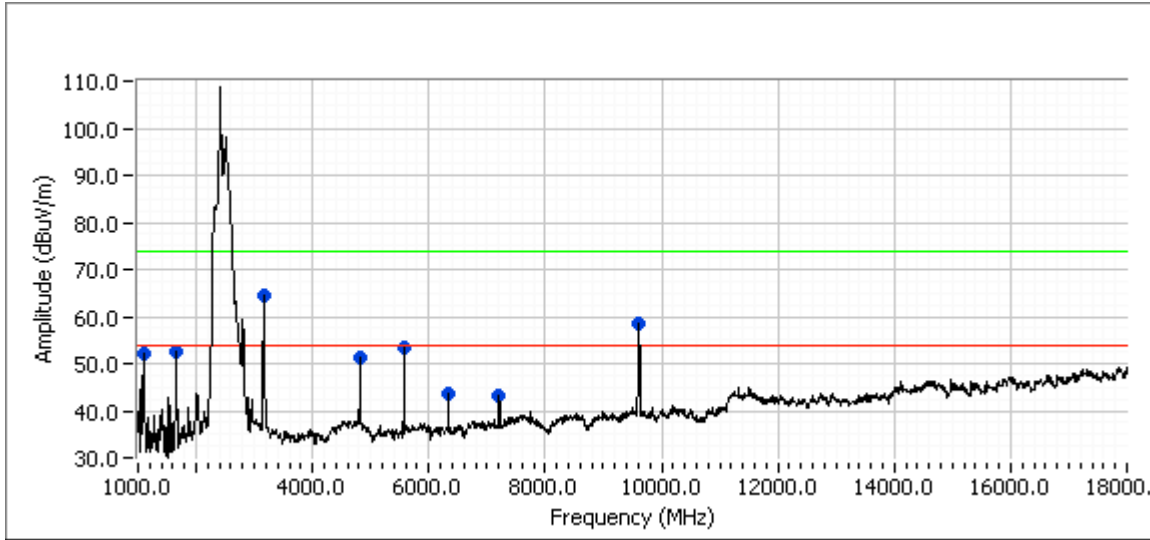

Frequency	Level	Pol	15.209 / 15.247		Detector	Azimuth	Height	Comments
MHz	dBμV/m	v/h	Limit	Margin	Pk/QP/Avg	degrees	meters	
2412.00	112.7	V	-	-	AVG	0	1.0	CH#1 Fundamental
2412.00	119.8	V	-	-	PK	0	1.0	CH#1 Fundamental
2412.00	97.1	H	-	-	AVG	304	1.7	CH#1 Fundamental
2412.00	103.9	H	-	-	PK	304	1.7	CH#1 Fundamental
1656.033	54.9	V	89.8	-34.9	PK	33	1.8	Non-restricted
3168.094	64.5	V	89.8	-25.3	PK	3	2.0	Non-restricted
4823.942	42.3	H	54.0	-11.8	AVG	327	1.6	Restricted
4823.942	54.7	H	74.0	-19.4	PK	327	1.6	Restricted
5577.814	58.1	V	89.8	-31.8	PK	252	1.0	Non-restricted
6336.125	47.5	H	89.8	-42.3	PK	129	1.2	Non-restricted
9648.127	55.4	H	89.8	-34.4	PK	255	1.4	Non-restricted
7236.064	48.9	V	89.8	-40.9	PK	96	1.0	Non-restricted

*No spurious emissions noted above 18 GHz*

UUT transmitting 802.11B on mid Channel: 2437 MHz (S2409PN36RTN)

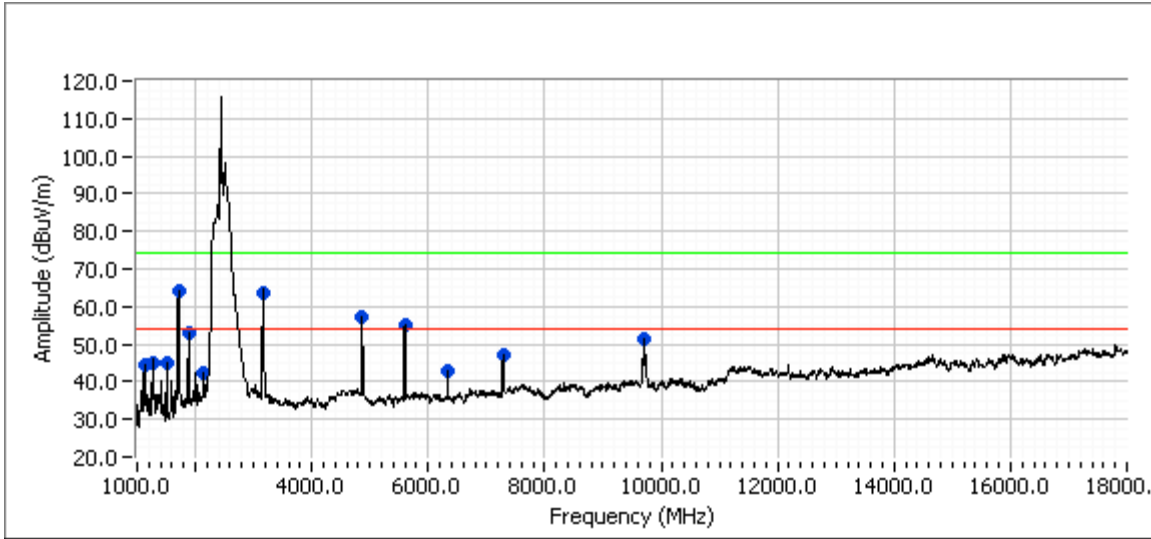

Frequency MHz	Level dBµV/m	Pol v/h	15.209 / 15.247		Detector Pk/QP/Avg	Azimuth degrees	Height meters	Comments
			Limit	Margin				
2437.00	115.4	V	-	-	AVG	7	1.0	CH#6 Fundamental
2437.00	122.1	V	-	-	PK	7	1.0	CH#6 Fundamental
2437.00	98.7	H	-	-	AVG	312	1.0	CH#6 Fundamental
2437.00	105.4	H	-	-	PK	312	1.0	CH#6 Fundamental
1125.481	36.8	V	92.1	-55.3	PK	299	1.0	Restricted Pk Below Avg Lim
3167.969	64.5	V	92.1	-27.7	PK	22	1.6	Non-restricted
4873.979	49.6	H	54.0	-4.4	AVG	32	1.6	Restricted
4873.979	61.4	H	74.0	-12.6	PK	32	1.6	Restricted
5605.323	61.2	V	92.1	-31.0	PK	257	1.0	Non-restricted
6335.935	48.0	H	75.4	-27.4	PK	104	1.2	Non-restricted
9748.179	55.9	V	92.1	-36.2	PK	115	1.0	Non-restricted
7310.970	43.4	V	54.0	-10.6	AVG	315	1.6	Restricted
7310.970	52.1	V	74.0	-21.9	PK	315	1.6	Restricted

No spurious emissions noted above 18 GHz

UUT transmitting 802.11B on high Channel: 2462 MHz (S2409PN36RTN)

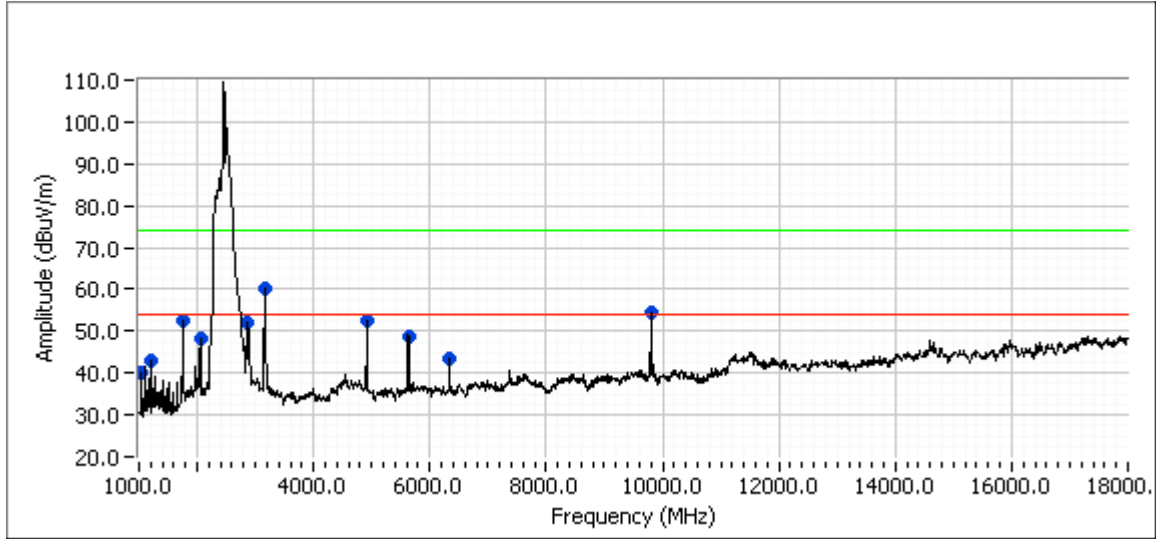

Frequency MHz	Level dBµV/m	Pol v/h	15.209 / 15.247		Detector Pk/QP/Avg	Azimuth degrees	Height meters	Comments
			Limit	Margin				
2462.00	110.5	V	-	-	AVG	360	1.1	CH#11 Fundamental
2462.00	117.3	V	-	-	PK	360	1.1	CH#11 Fundamental
2462.00	94.0	H	-	-	AVG	314	1.0	CH#11 Fundamental
2462.00	101.1	H	-	-	PK	314	1.0	CH#11 Fundamental
3167.941	51.5	V	87.3	-35.9	PK	63	1.2	Non-restricted
4924.097	43.3	H	54.0	-10.7	AVG	318	1.0	Restricted
4924.097	55.0	H	74.0	-19.1	PK	318	1.0	Restricted
5628.028	54.3	V	87.3	-33.1	PK	79	2.0	Non-restricted
6335.884	45.4	H	71.1	-25.7	PK	105	1.2	Non-restricted
1755.617	52.6	V	87.3	-34.7	PK	8	1.2	Non-restricted
1200.039	38.5	V	87.3	-48.8	PK	316	1.4	Restricted Pk below Avg Limit
2852.476	41.8	V	54.0	-12.2	AVG	248	1.0	Restricted
2852.476	56.2	V	74.0	-17.8	PK	248	1.0	Restricted
9848.188	53.8	H	71.1	-17.3	PK	253	1.4	Non-restricted

No spurious emissions noted above 18 GHz

UUT transmitting 802.11G on low Channel: 2412 MHz (S2409PN36RTN)

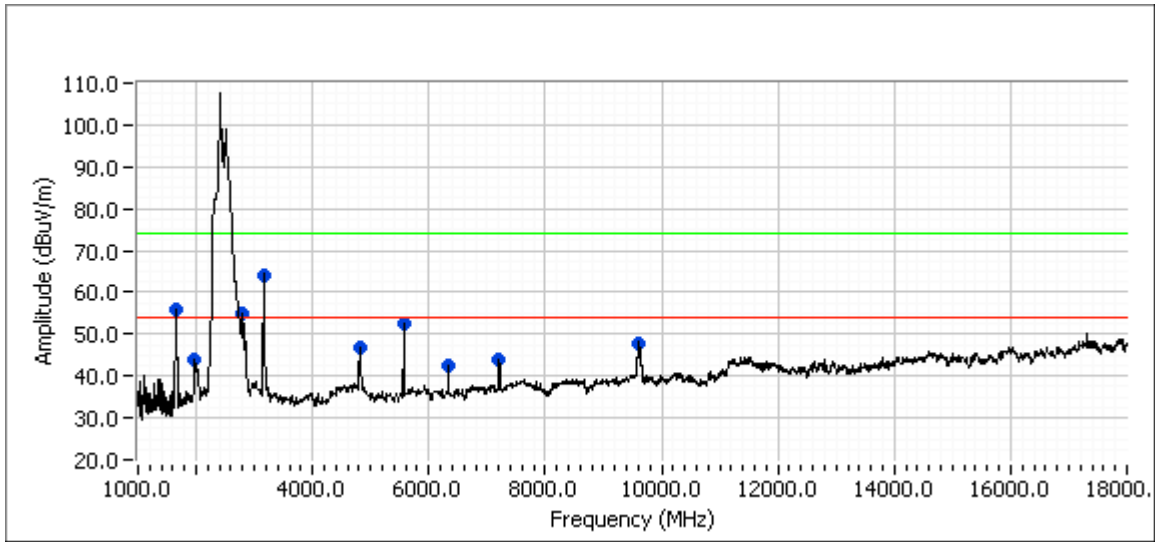

Frequency MHz	Level dBµV/m	Pol v/h	15.209 / 15.247		Detector Pk/OP/Avg	Azimuth degrees	Height meters	Comments
			Limit	Margin				
2412.00	110.8	V	-	-	AVG	1	1.0	CH#1 Fundamental
2412.00	120.8	V	-	-	PK	1	1.0	CH#1 Fundamental
2412.00	90.1	H	-	-	AVG	1	1.0	CH#1 Fundamental
2412.00	99.9	H	-	-	PK	1	1.0	CH#1 Fundamental
3168.094	66.7	V	90.8	-24.1	PK	6	1.8	Non-restricted
2725.595	51.2	H	54.0	-2.8	AVG	340	1.4	Restricted
2725.595	62.3	H	74.0	-11.7	PK	340	1.4	Restricted
1654.531	58.7	V	90.8	-32.1	PK	20	1.2	Non-restricted
5584.653	59.2	V	90.8	-31.6	PK	103	2.0	Non-restricted
4822.093	40.4	H	54.0	-13.6	AVG	331	1.6	Restricted
4822.093	52.0	H	74.0	-22.0	PK	331	1.6	Restricted
7234.950	50.0	V	90.8	-40.8	PK	95	1.0	Non-restricted

No spurious emissions noted above 18 GHz

UUT transmitting 802.11G on mid Channel: 2437 MHz (S2409PN36RTN)

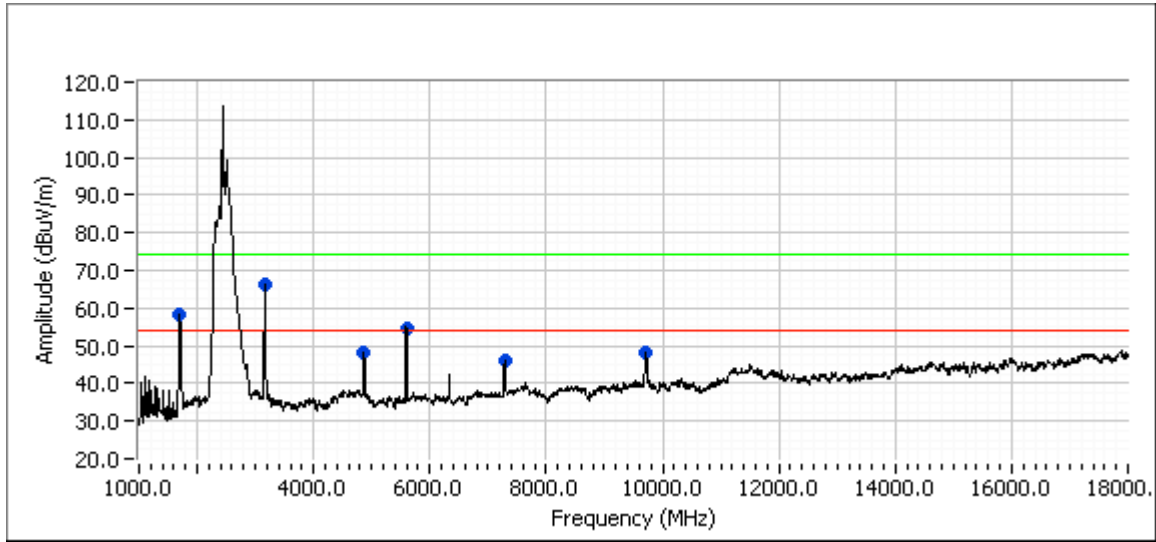

Frequency	Level	Pol	15.209 / 15.247		Detector	Azimuth	Height	Comments
MHz	dBμV/m	v/h	Limit	Margin	Pk/OP/Avg	degrees	meters	
2437.00	111.9	V	-	-	AVG	7	1.0	Ch#6 Fundamental
2437.00	121.5	V	-	-	PK	7	1.0	Ch#6 Fundamental
2437.00	92.9	H	-	-	AVG	308	1.0	Ch#6 Fundamental
2437.00	102.0	H	-	-	PK	308	1.0	Ch#6 Fundamental
1703.165	44.5	V	54.0	-9.5	AVG	169	1.1	Restricted
1703.165	55.9	V	74.0	-18.1	PK	169	1.1	Restricted
3168.004	67.2	V	91.5	-24.3	PK	7	2.0	Non-restricted
4874.335	46.6	H	54.0	-7.4	AVG	323	1.6	Restricted
4874.335	58.0	H	74.0	-16.0	PK	323	1.6	Restricted
5604.142	62.5	V	91.5	-29.0	PK	257	1.0	Non-restricted

No spurious emissions noted above 18 GHz

UUT transmitting 802.11G on high Channel: 2462 MHz (S2409PN36RTN)

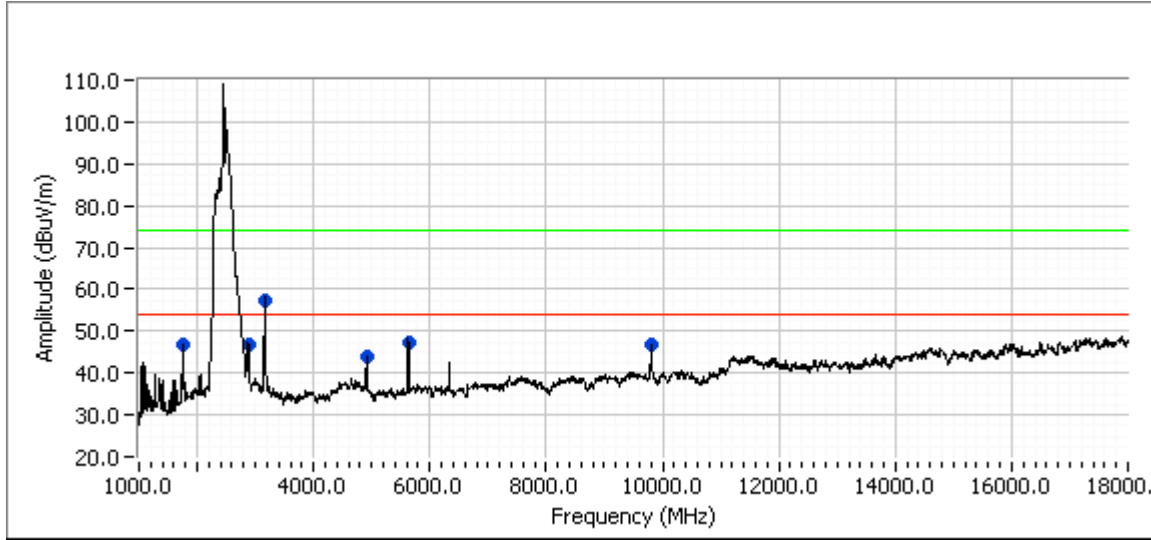

Frequency MHz	Level dBμV/m	Pol v/h	15.209 / 15.247		Detector Pk/QP/Avg	Azimuth degrees	Height meters	Comments
			Limit	Margin				
2462.00	104.3	V	-	-	AVG	336	1.4	Ch#11 Fundamental
2462.00	114.5	V	-	-	PK	336	1.4	Ch#11 Fundamental
2462.00	86.3	H	-	-	AVG	307	1.0	Ch#11 Fundamental
2462.00	96.5	H	-	-	PK	307	1.0	Ch#11 Fundamental
1752.669	56.8	V	84.5	-27.7	PK	18	1.4	Non-restricted
3167.975	60.0	V	84.5	-24.6	PK	18	1.6	Non-restricted
5631.278	55.4	V	84.5	-29.1	PK	254	1.0	Non-restricted
2874.980	34.2	V	54.0	-19.8	AVG	79	1.7	Restricted
2874.980	44.9	V	74.0	-29.1	PK	79	1.7	Restricted
4922.749	41.0	H	54.0	-13.0	AVG	322	1.4	Restricted
4922.749	52.6	H	74.0	-21.5	PK	322	1.4	Restricted
9846.313	50.3	H	66.5	-16.2	PK	254	1.4	Non-restricted

No spurious emissions noted above 18 GHz

### ISM Radiated Emissions in Restricted bands (2.4 GHz Band Edges)

FCC Specifications: Paragraph 15.247(c)

**Procedure:**

Since this is a 2.4 GHz product, there is a restricted band that begins immediately at the high end of the operating band and another that begins 10 MHz below the low end of the operating band.



This test was conducted on a 3-meter OATS #4 at Elliott labs Sunnyvale facility. There are three steps to performing this test.

STEP 1) The first involves making a radiated measurement of the fundamental signal with the UUT on the operating channel closest to the edge of the band. The unit was placed on a rotating wooden table 80cm above the OATS ground plane. A Horn antenna was secured to a mast 3 meters away. The test equipment was configured as shown below.

The EUT was rotated 360 degrees and the height of the antenna adjusted from 1 to 4 meters above the ground plane to determine the maximum level of the emission. The level of the fundamental emission was measured in two modes, "Peak" and "Average" using RBW and VBW of 1MHz/1MHz and 1MHz/10Hz respectively.

STEP 2) A second measurement (conducted) is made using narrower bandwidths (100 kHz) to determine a -dBc (delta dB) level between the peak of the fundamental level (measured in a 100 kHz BW) and the highest level within the restricted band near the operating band.

STEP 3) A third and final measurement (conducted) is made to determine the apparent drop in fundamental carrier power when the RBW is narrowed from 1MHz (in the reference measurement) to 100kHz (for the delta dB measurement). This is referred to below as the "BW Delta".

The level of the emission in the restricted band is then calculated using the following formulas.

$\text{Restricted band level (AVG)} = \text{AVG reference level} - \text{delta dB} - \text{BW Delta dB}$ $\text{Restricted band level (Peak)} = \text{Peak reference level} - \text{delta dB} - \text{BW Delta dB}$
---



**Results: Antenna: S2403BHN36RTN**

802.11 B Band Edge (Restricted band @ 2.390GHz)												
Pol	Fundamental Radiated Ref Msmt		Delta Msmt		RBW Msmt		Radiated Level at Band Edge		Specification		Delta (dB below Limit)	
	Peak dbuv/m	Avg dbuv/m	Peak dBc	Avg dBc	Pk dB	Avg dB	Peak dBuv/m	Avg dBuv/m	Peak dBuv/m	Avg dBuv/m	Peak dBuv/m	Avg dBuv/m
Vert	113.7	107.7	43.12	48.3	9.78	10.71	60.8	48.69	74	54	13.2	5.31
Horz	96.9	89.6					44	30.59			30	23.41
802.11 B Band Edge (Restricted band @ 2.4835GHz)												
Pol	Fundamental Radiated Ref Msmt		Delta Msmt		RBW Msmt		Radiated Level at Band Edge		Specification		Delta (dB below Limit)	
	Peak dbuv/m	Avg dbuv/m	Peak dBc	Avg dBc	Pk dB	Avg dB	Peak dBuv/m	Avg dBuv/m	Peak dBuv/m	Avg dBuv/m	Peak dBuv/m	Avg dBuv/m
Vert	109.3	103.3	47.15	47.99	10.24		62.15	45.07	74	54	11.85	8.93
Horz	97.4	90.7					50.25	32.47			23.75	21.53
802.11 G Band Edge (Restricted band @ 2.390GHz)												
Pol	Fundamental Radiated Ref Msmt		Delta Msmt		RBW Msmt		Radiated Level at Band Edge		Specification		Delta (dB below Limit)	
	Peak dbuv/m	Avg dbuv/m	Peak dBc	Avg dBc	Pk dB	Avg dB	Peak dBuv/m	Avg dBuv/m	Peak dBuv/m	Avg dBuv/m	Peak dBuv/m	Avg dBuv/m
Vert	115.2	105.3	34.25	43.53	15.11	15.35	65.84	46.42	74	54	8.16	7.58
Horz	93.7	84.6					44.34	25.72			29.66	28.28
802.11 G Band Edge (Restricted band @ 2.4835GHz)												
Pol	Fundamental Radiated Ref Msmt		Delta Msmt		RBW Msmt		Radiated Level at Band Edge		Specification		Delta (dB below Limit)	
	Peak dbuv/m	Avg dbuv/m	Peak dBc	Avg dBc	Pk dB	Avg dB	Peak dBuv/m	Avg dBuv/m	Peak dBuv/m	Avg dBuv/m	Peak dBuv/m	Avg dBuv/m
Vert	109.6	99.8	31.19	41.88	14.67	13.15	63.74	44.77	74	54	10.26	9.23
Horz	96.5	87					50.64	31.97			23.36	22.03

Radiated emissions at band edge sample calculation (Vertical, Avg, 802.11 B, Low Edge):

$$\text{Emission Level} = \text{Fund Ref msmt} - \text{Delta msmt} - \text{RBW Delta msmt}$$

Example: 107.7 dBuV/m – 48.3 dBc – 10.71dB = 48.69dBuV/m  
 54 dBuV/m - 48.69dBuV/m = 5.31 dB margin

**Results: Antenna: S2409PN36RTN**

<b>802.11 B Band Edge (Restricted band @ 2.390GHz)</b>												
Pol	Fundamental Radiated Ref Msmt		Delta Msmt		RBW Msmt		Radiated Level at Band Edge		Specification		Delta (dB below Limit)	
	Peak dbuv/m	Avg dbuv/m	Peak dBc	Avg dBc	Pk dB	Avg dB	Peak dBuv/m	Avg dBuv/m	Peak dBuv/m	Avg dBuv/m	Peak dBuv/m	Avg dBuv/m
Vert	119.8	112.7	43.12	48.3	9.78	10.71	66.9	53.69	74	54	7.1	0.31
Horz	103.9	97.1					51	38.09			23	15.91
<b>802.11 B Band Edge (Restricted band @ 2.4835GHz)</b>												
Pol	Fundamental Radiated Ref Msmt		Delta Msmt		RBW Msmt		Radiated Level at Band Edge		Specification		Delta (dB below Limit)	
	Peak dbuv/m	Avg dbuv/m	Peak dBc	Avg dBc	Pk dB	Avg dB	Peak dBuv/m	Avg dBuv/m	Peak dBuv/m	Avg dBuv/m	Peak dBuv/m	Avg dBuv/m
Vert	117.3	110.5	47.15	47.99		10.24	70.15	52.27	74	54	3.85	1.73
Horz	101.1	94					53.95	35.77			20.05	18.23
<b>802.11 G Band Edge (Restricted band @ 2.390GHz)</b>												
Pol	Fundamental Radiated Ref Msmt		Delta Msmt		RBW Msmt		Radiated Level at Band Edge		Specification		Delta (dB below Limit)	
	Peak dbuv/m	Avg dbuv/m	Peak dBc	Avg dBc	Pk dB	Avg dB	Peak dBuv/m	Avg dBuv/m	Peak dBuv/m	Avg dBuv/m	Peak dBuv/m	Avg dBuv/m
Vert	120.8	110.8	34.25	43.53	15.11	15.35	71.44	51.92	74	54	2.56	2.08
Horz	99.9	90.1					50.54	31.22			23.46	22.78
<b>802.11 G Band Edge (Restricted band @ 2.4835GHz)</b>												
Pol	Fundamental Radiated Ref Msmt		Delta Msmt		RBW Msmt		Radiated Level at Band Edge		Specification		Delta (dB below Limit)	
	Peak dbuv/m	Avg dbuv/m	Peak dBc	Avg dBc	Pk dB	Avg dB	Peak dBuv/m	Avg dBuv/m	Peak dBuv/m	Avg dBuv/m	Peak dBuv/m	Avg dBuv/m
Vert	114.5	104.3	31.19	41.88	14.67	13.15	68.64	49.27	74	54	5.36	4.73
Horz	96.5	86.3					50.64	31.27			23.36	22.73

### 802.11 B Restricted Band at 2390MHz Plots

Agilent 15:26:05 Dec 30, 2004

802.11 B Low band edge, PEAK -dBc msmt (#861)

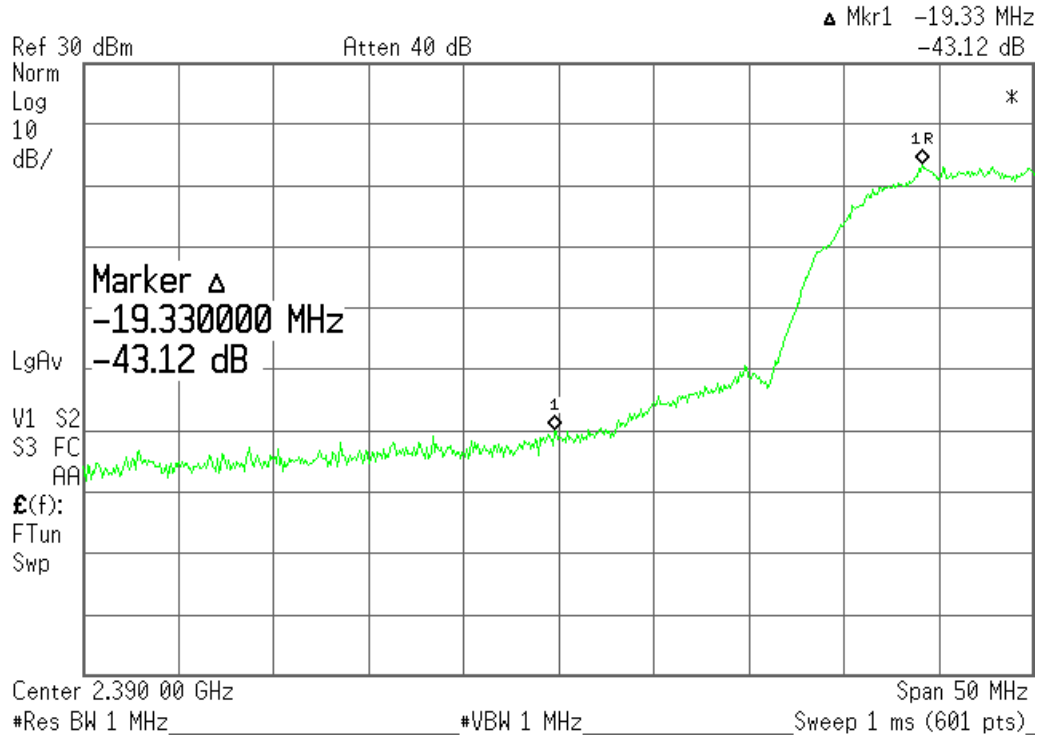

Agilent 16:26:55 Dec 29, 2004

802.11 B Low band edge, AVG -dBc msmt (#849)

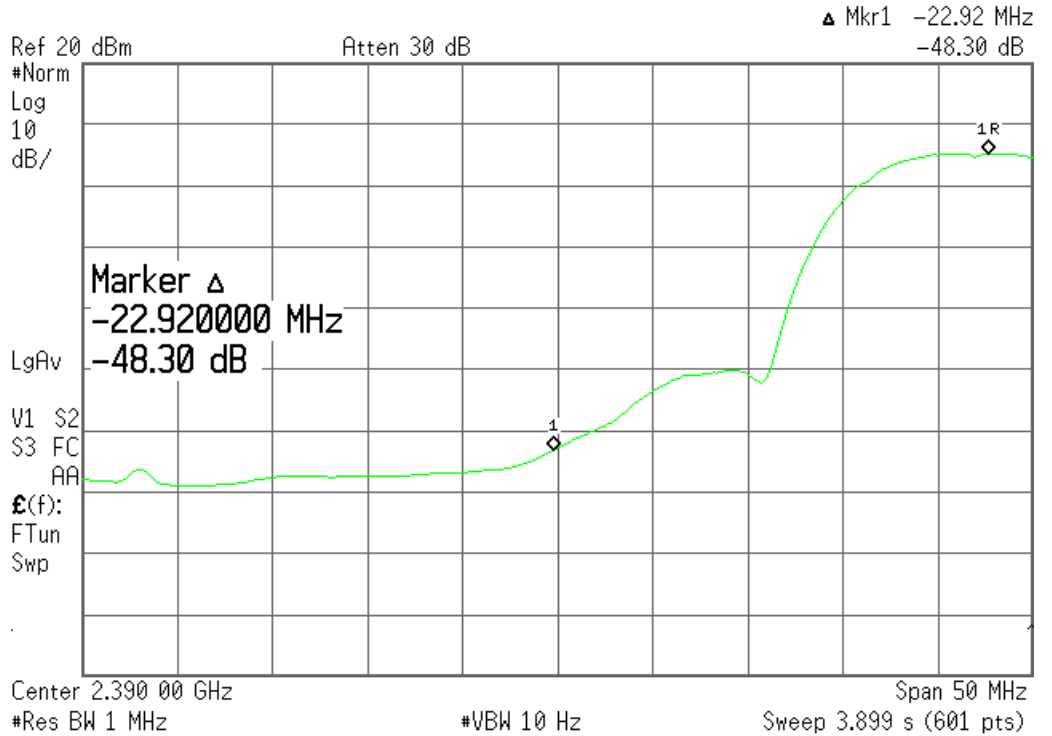

\* Agilent 13:13:04 Nov 26, 2004

802.11 B Low band edge, PEAK BW Delta msmt (#793)

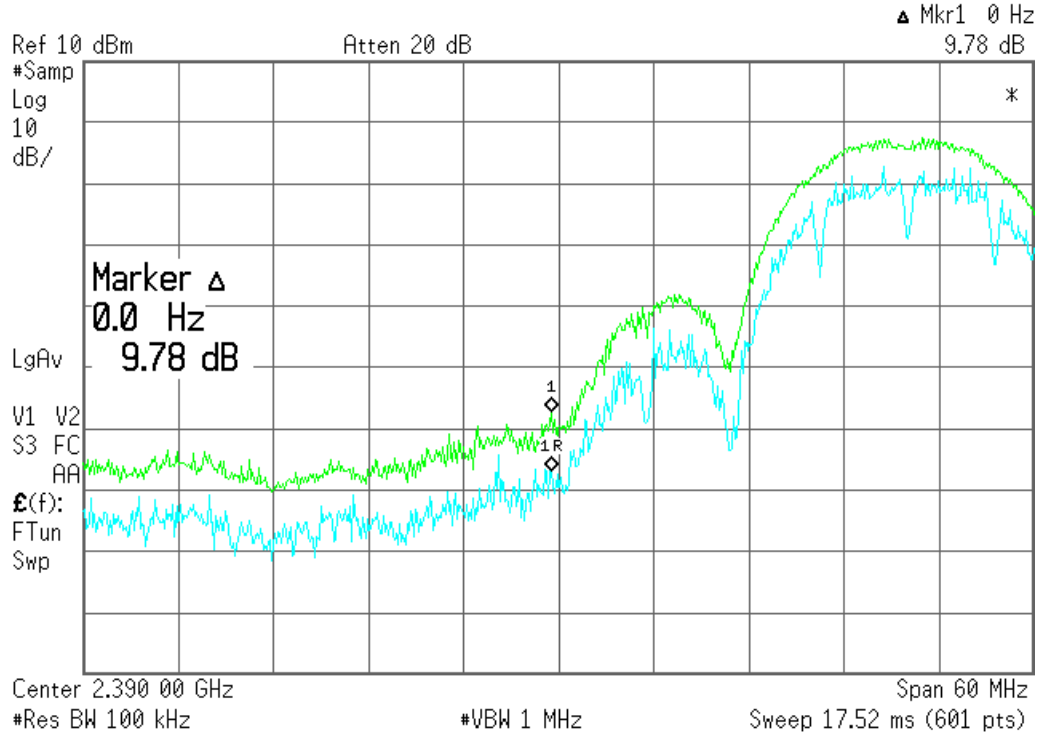

\* Agilent 16:36:43 Dec 29, 2004

802.11 B Low band edge, AVG BW Delta msmt (#850)

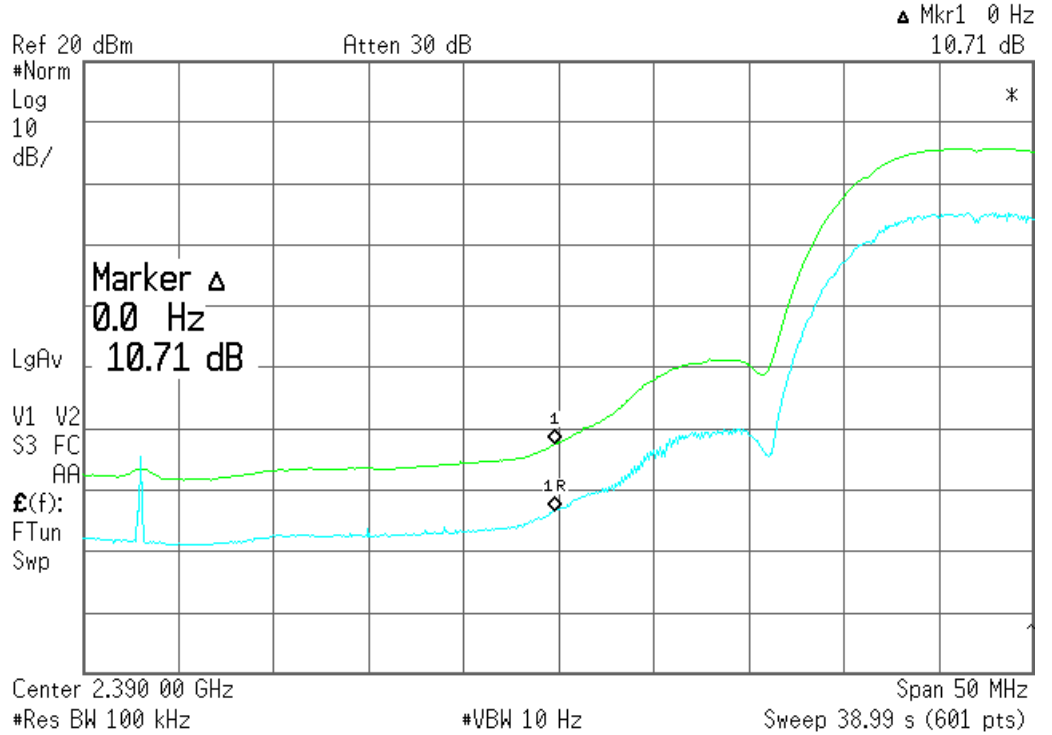

### 802.11 B Restricted Band at 2483.5 MHz Plots

802.11 B High band edge, PEAK -dBc msmt (#825)

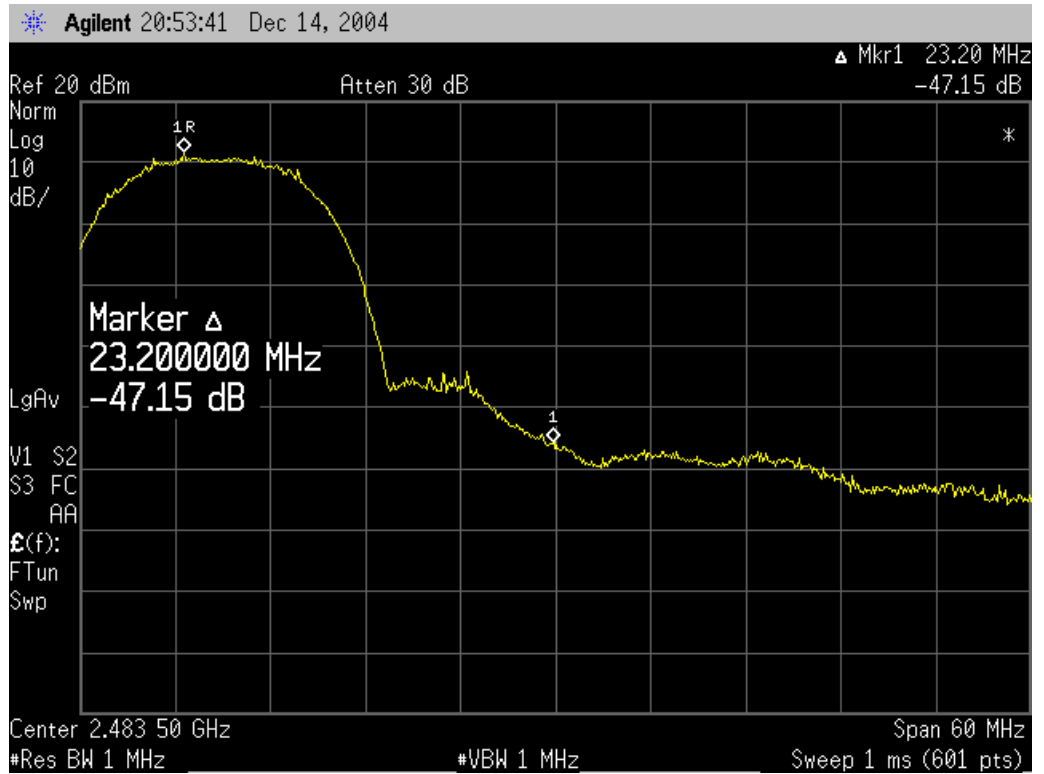

802.11 B High band edge, AVG -dBc msmt (#826)

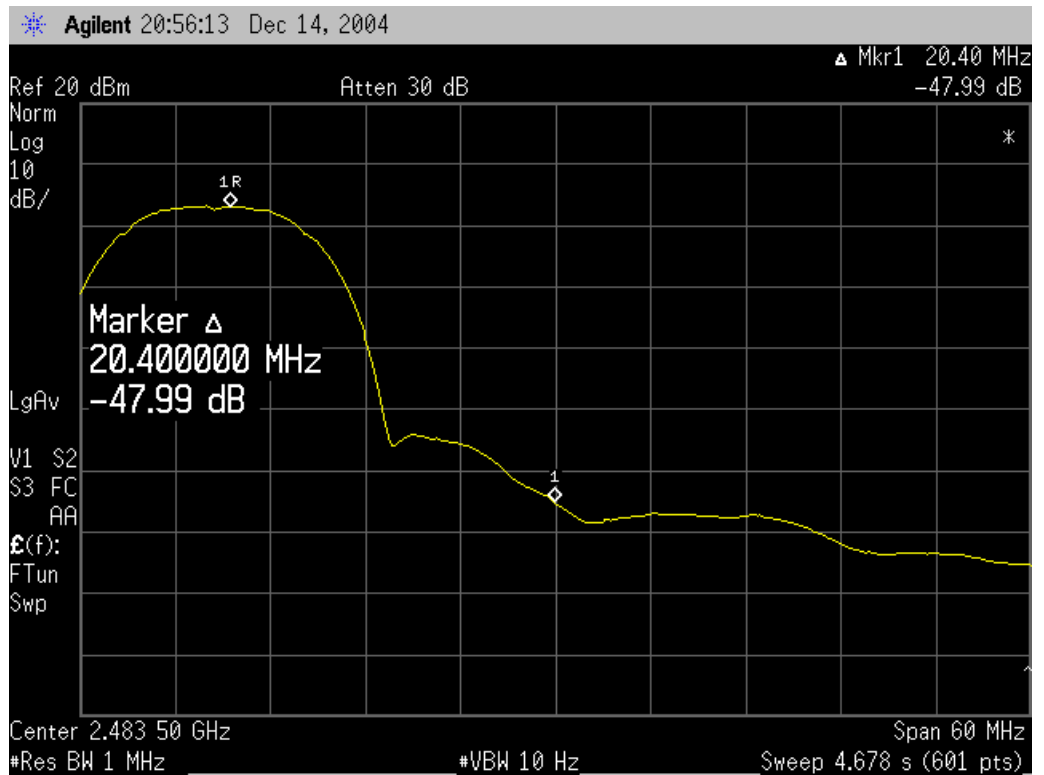

802.11 B High band edge, PEAK BW Delta msmt (*Measurement not required*)

Agilent 16:44:44 Dec 29, 2004

Mkr1 0 Hz  
10.24 dB

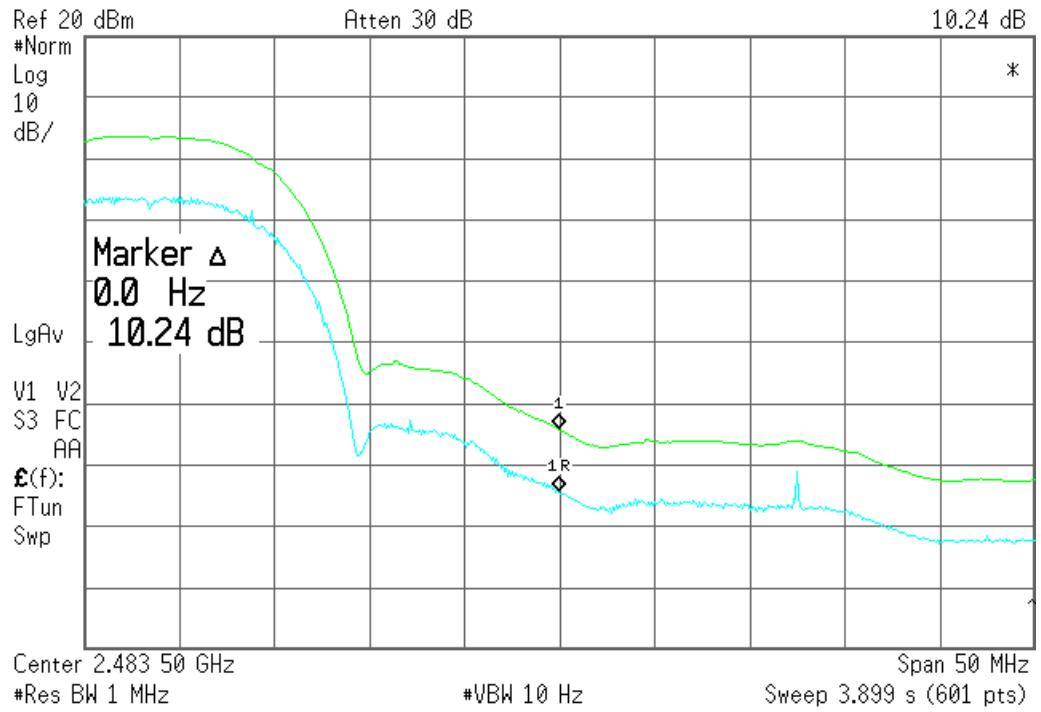

802.11 B High band edge, AVG BW Delta msmt (#851)

### 802.11 G Restricted Band at 2390MHz Plots

Agilent 14:10:40 Nov 26, 2004

802.11 G Low band edge, PEAK -dBc msmt (#801)

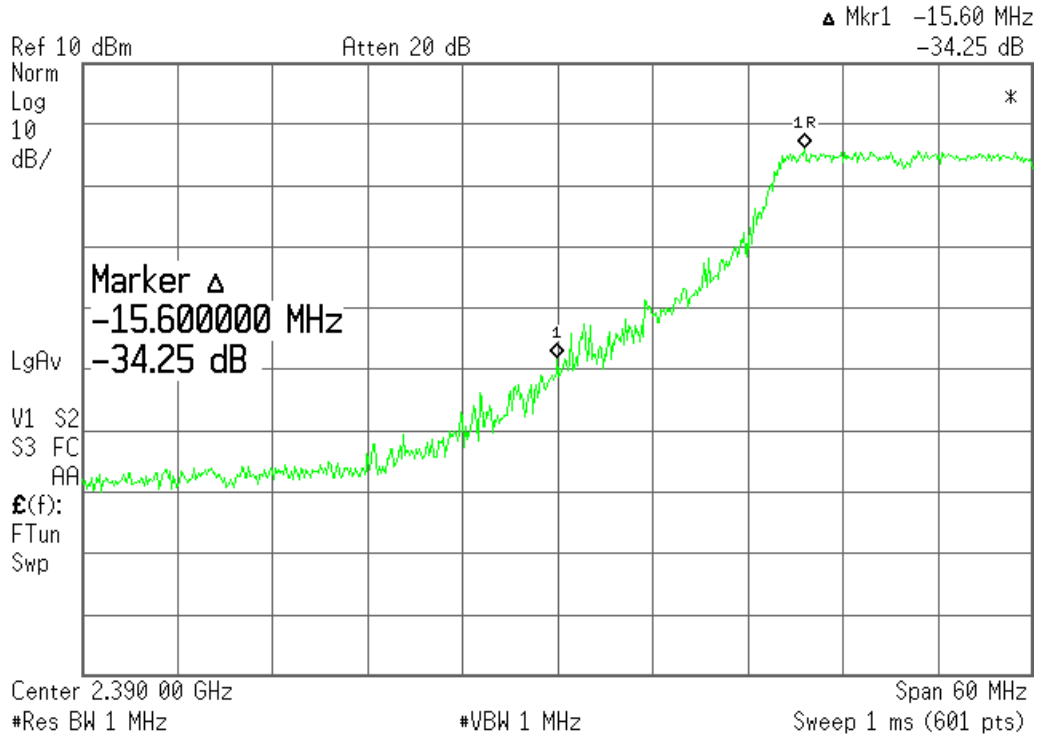

Agilent 14:11:28 Nov 26, 2004

802.11 G Low band edge, AVG -dBc msmt (#802)

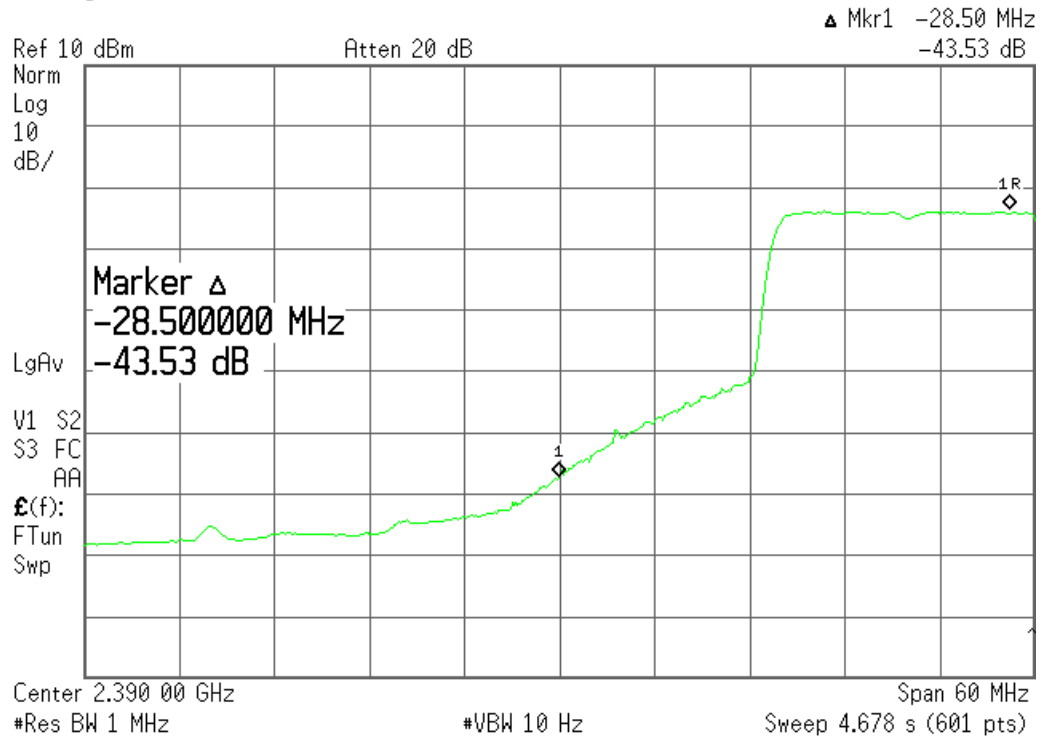

Agilent 14:13:05 Nov 26, 2004

Mkr1 0 Hz  
15.11 dB

802.11 G Low band  
edge, PEAK BW Delta  
(803)

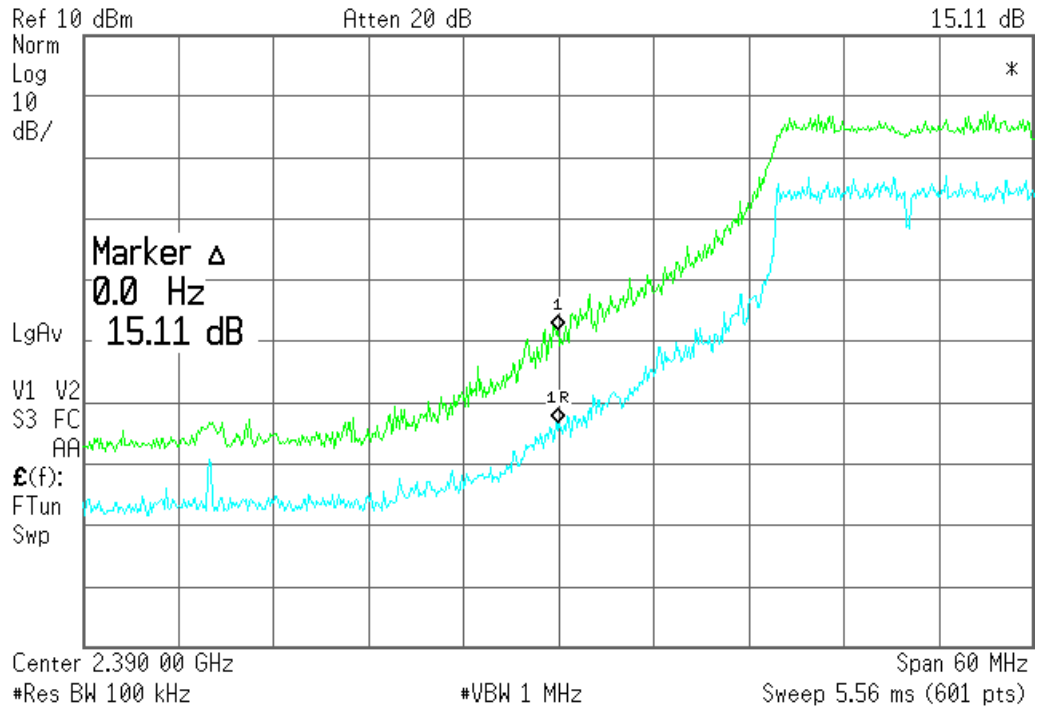

Agilent 15:46:41 Dec 30, 2004

Mkr1 0 Hz  
15.35 dB

802.11 G Low band  
edge, AVG BW Delta  
(862)

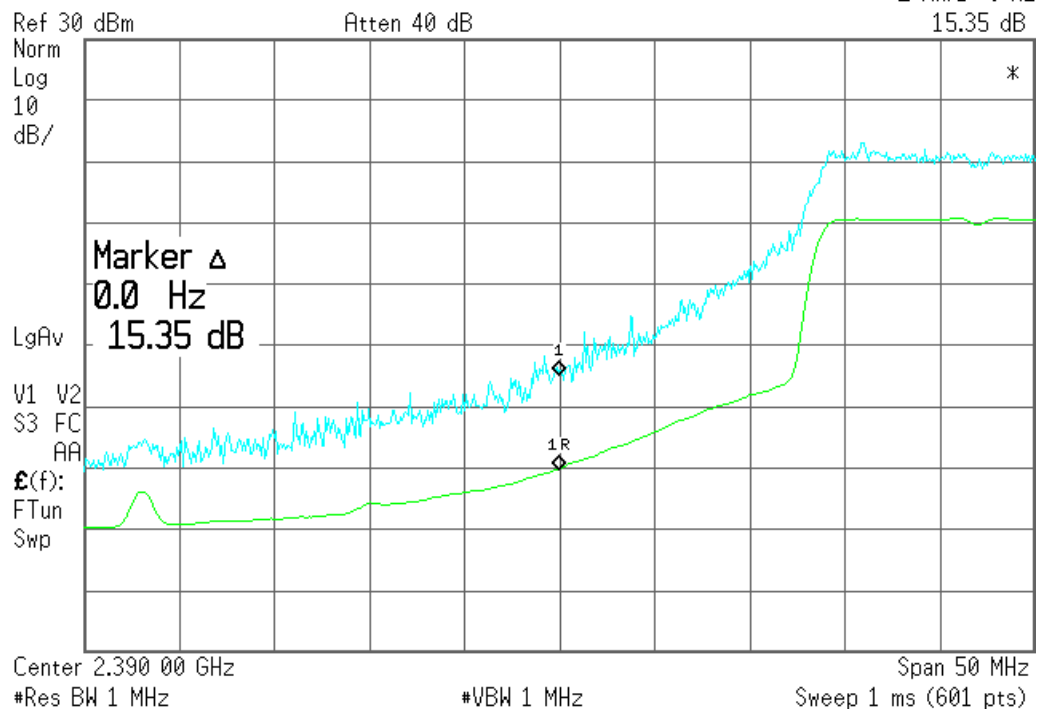



### 802.11 G Restricted Band at 2483.5 MHz Plots

Agilent 13:28:42 Nov 26, 2004

802.11 G High band edge, PEAK -dBc msmt (#797)

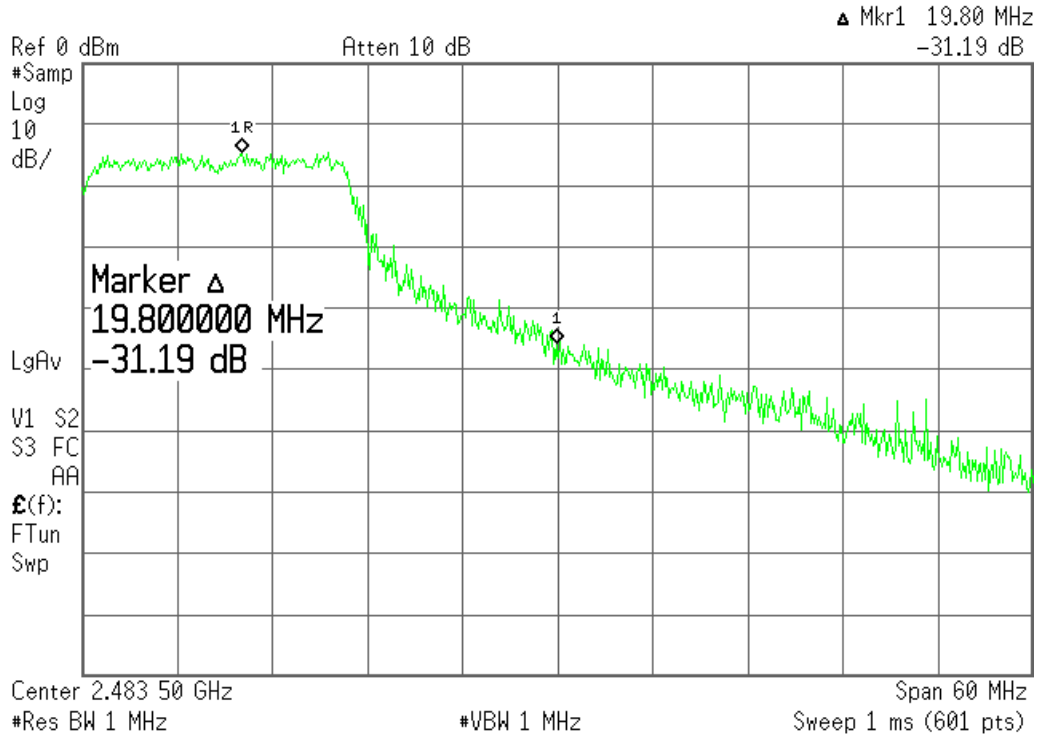

Agilent 16:04:37 Dec 30, 2004

802.11 B High band edge, AVG -dBc msmt (#865)

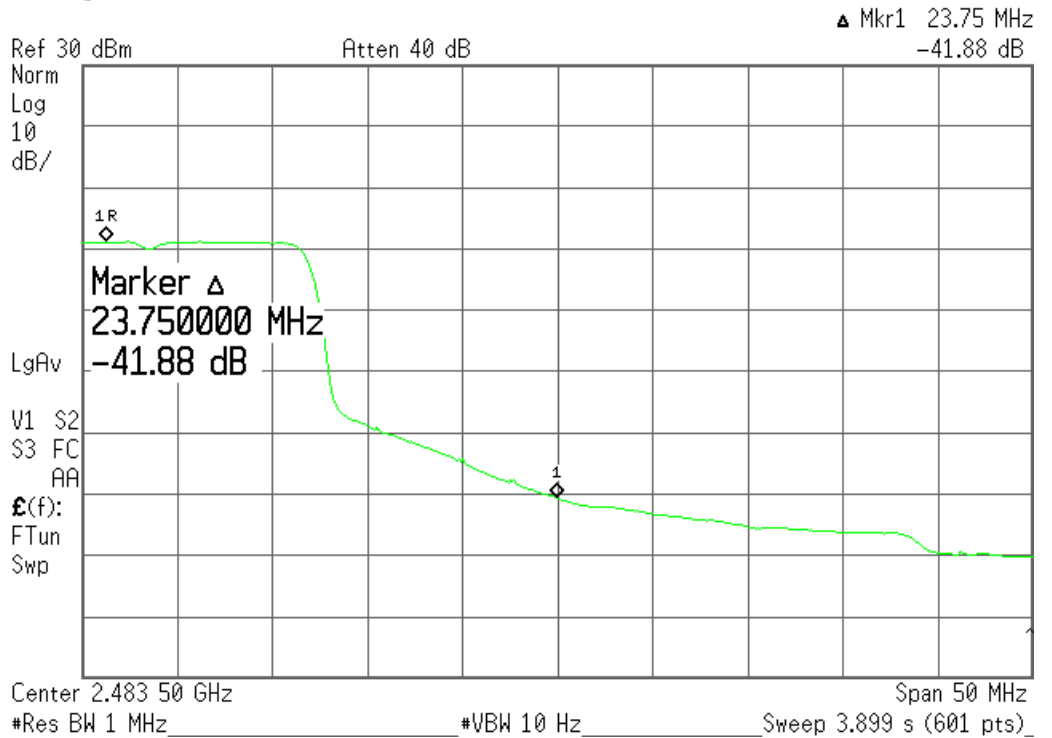

\* Agilent 15:59:04 Dec 30, 2004

802.11 G High band edge, PEAK BW Delta msmt (#864)

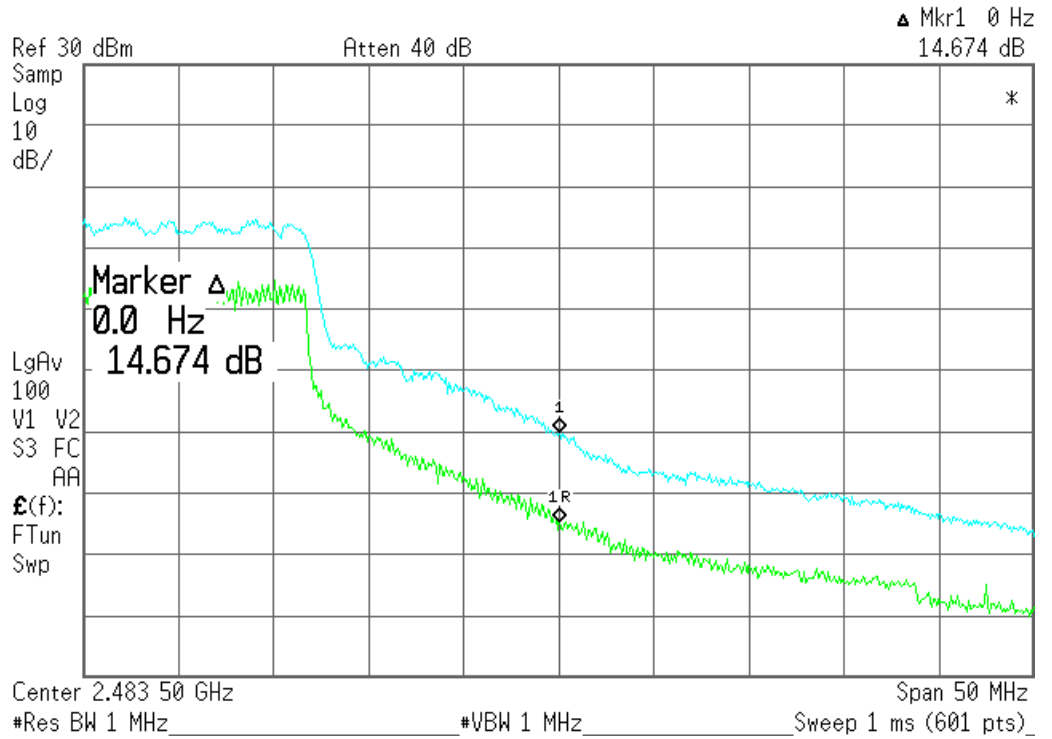

\* Agilent 16:17:14 Dec 30, 2004

802.11 G High band edge, AVG BW Delta msmt (#866)

