



FCC TEST REPORT (15.407)

REPORT NO.: RF990806C19-1

MODEL NO.: SC6000

FCC ID: RV7-SC6000

RECEIVED: Aug. 06, 2010

TESTED: Aug. 10 ~ Sep. 06, 2010

ISSUED: Sep. 09, 2010

APPLICANT: Trilliant Networks, Inc.

ADDRESS: 1100 Island Drive Redwood City California United States 95065

ISSUED BY: Bureau Veritas Consumer Products Services (H.K.) Ltd., Taoyuan Branch

LAB ADDRESS: No. 47, 14th Ling, Chia Pau Tsuen, Lin Kou Hsiang, Taipei Hsien 244, Taiwan, R.O.C.

TEST LOCATION: No. 19, Hwa Ya 2nd Rd, Wen Hwa Tsuen, Kwei Shan Hsiang, Taoyuan Hsien 333, Taiwan, R.O.C.

This test report consists of 45 pages in total. It may be duplicated completely for legal use with the approval of the applicant. It should not be reproduced except in full, without the written approval of our laboratory. The client should not use it to claim product endorsement by TAF or any government agency. The test results in the report only apply to the tested sample.





TABLE OF CONTENTS

1.	CERTIFICATION.....	4
2.	SUMMARY OF TEST RESULTS	5
2.1	MEASUREMENT UNCERTAINTY.....	5
3.	GENERAL INFORMATION.....	6
3.1	GENERAL DESCRIPTION OF EUT	6
3.2	DESCRIPTION OF TEST MODES	7
3.2.1	CONFIGURATION OF SYSTEM UNDER TEST	7
3.2.2	TEST MODE APPLICABILITY AND TESTED CHANNEL DETAIL	8
3.3	GENERAL DESCRIPTION OF APPLIED STANDARDS	10
3.4	DESCRIPTION OF SUPPORT UNITS	10
4.	TEST TYPES AND RESULTS	11
4.1	RADIATED EMISSION MEASUREMENT	11
4.1.1	LIMITS OF RADIATED EMISSION MEASUREMENT.....	11
4.1.2	LIMITS OF UNWANTED EMISSION OUT OF THE RESTRICTED BANDS	11
4.1.3	TEST INSTRUMENTS.....	12
4.1.4	TEST PROCEDURES	13
4.1.5	DEVIATION FROM TEST STANDARD	13
4.1.6	TEST SETUP.....	14
4.1.7	EUT OPERATING CONDITION.....	14
4.1.8	TEST RESULTS	15
4.2	CONDUCTED EMISSION MEASUREMENT	19
4.2.1	LIMITS OF CONDUCTED EMISSION MEASUREMENT.....	19
4.2.2	TEST INSTRUMENTS.....	19
4.2.3	TEST PROCEDURES	20
4.2.4	DEVIATION FROM TEST STANDARD	20
4.2.5	TEST SETUP.....	21
4.2.6	EUT OPERATING CONDITIONS	21
4.2.7	TEST RESULTS	22
4.3	MAXIMUM CONDUCTED OUTPUT POWER MEASUREMENT	24
4.3.1	LIMITS OF MAXIMUM CONDUCTED OUTPUT POWER MEASUREMENT.....	24
4.3.2	TEST INSTRUMENTS.....	24
4.3.3	TEST PROCEDURE.....	25
4.3.4	DEVIATION FROM TEST STANDARD	25
4.3.5	TEST SETUP.....	25
4.3.6	EUT OPERATING CONDITIONS	25
4.3.7	TEST RESULTS	26
4.4	PEAK POWER EXCURSION MEASUREMENT	28
4.4.1	LIMITS OF PEAK POWER EXCURSION MEASUREMENT.....	28
4.4.2	TEST INSTRUMENTS.....	28
4.4.3	TEST PROCEDURE.....	28
4.4.4	DEVIATION FROM TEST STANDARD	29
4.4.5	TEST SETUP.....	29
4.4.6	EUT OPERATING CONDITIONS	29
4.4.7	TEST RESULTS	30
4.5	PEAK POWER SPECTRAL DENSITY MEASUREMENT	32
4.5.1	LIMITS OF PEAK POWER SPECTRAL DENSITY MEASUREMENT.....	32
4.5.2	TEST INSTRUMENTS.....	32
4.5.3	TEST PROCEDURES	32



A D T

4.5.4	DEVIATION FROM TEST STANDARD	33
4.5.5	TEST SETUP	33
4.5.6	EUT OPERATING CONDITIONS	33
4.5.7	TEST RESULTS	34
4.6	FREQUENCY STABILITY.....	35
4.6.1	LIMITS OF FREQUENCY STABILITY MEASUREMENT	35
4.6.2	TEST INSTRUMENTS.....	35
4.6.3	TEST PROCEDURE.....	35
4.6.4	DEVIATION FROM TEST STANDARD	36
4.6.5	TEST SETUP.....	36
4.6.6	EUT OPERATING CONDITION.....	36
4.6.7	TEST RESULTS	37
4.7	BAND EDGES MEASUREMENT	38
4.7.1	TEST INSTRUMENTS.....	38
4.7.2	TEST PROCEDURE.....	38
4.7.3	EUT OPERATING CONDITION.....	38
4.7.4	TEST RESULTS	39
5.	PHOTOGRAPHS OF THE TEST CONFIGURATION.....	43
6.	INFORMATION ON THE TESTING LABORATORIES	44
7.	APPENDIX A - MODIFICATIONS RECORDERS FOR ENGINEERING CHANGES TO THE EUT BY THE LAB	45



1. CERTIFICATION

PRODUCT: Dual Radio Concurrent AP/CB
MODEL: SC6000
BRAND: SkyPilot
APPLICANT: Trilliant Networks, Inc.
TEST SAMPLE: ENGINEERING SAMPLE
TESTED: Aug. 10 ~ Sep. 06, 2010
STANDARDS: **FCC Part 15, Subpart E (Section 15.407)**
ANSI C63.4-2003

The above equipment (Model: SC6000) has been tested by **Bureau Veritas Consumer Products Services (H.K.) Ltd., Taoyuan Branch**, and found compliance with the requirement of the above standards. The test record, data evaluation & Equipment Under Test (EUT) configurations represented herein are true and accurate accounts of the measurements of the sample's EMC characteristics under the conditions specified in this report.

PREPARED BY : Andrea Hsia , **DATE** : Sep. 09, 2010
Andrea Hsia / Specialist

TECHNICAL ACCEPTANCE : Long Chen , **DATE** : Sep. 09, 2010
Responsible for RF Long Chen / Senior Engineer

APPROVED BY : Gary Chang , **DATE** : Sep. 09, 2010
Gary Chang / Assistant Manager

2. SUMMARY OF TEST RESULTS

The EUT has been tested according to the following specifications:

APPLIED STANDARD: FCC PART 15, SUBPART E			
STANDARD SECTION	TEST TYPE AND LIMIT	RESULT	REMARK
15.407(b)(5)	AC Power Conducted Emission	PASS	Meet the requirement of limit. Minimum passing margin is -1.08dB at 12.438MHz.
15.407(b/1/2/3) (b)(5)	Electric Field Strength Spurious Emissions, 30MHz ~ 40000MHz	PASS	Meet the requirement of limit. Minimum passing margin is -1.3dB at 339.04MHz.
15.407(a/1/2/3)	Peak Transmit Power	PASS	Meet the requirement of limit.
15.407(a)(6)	Peak Power Excursion	PASS	Meet the requirement of limit.
15.407(a/1/2/3)	Peak Power Spectral Density	PASS	Meet the requirement of limit.
15.407(g)	Frequency Stability	PASS	Meet the requirement of limit.
15.203	Antenna Requirement	PASS	Antenna connector is MMCX not a standard connector.

2.1 MEASUREMENT UNCERTAINTY

Where relevant, the following measurement uncertainty levels have been estimated for tests performed on the EUT as specified in CISPR 16-4-2:

MEASUREMENT	FREQUENCY	UNCERTAINTY
Conducted emissions	9kHz~30MHz	2.44 dB
Radiated emissions	30MHz ~ 200MHz	3.34 dB
	200MHz ~1000MHz	3.35 dB
	1GHz ~ 18GHz	2.26 dB
	18GHz ~ 40GHz	1.94 dB

This uncertainty represents an expanded uncertainty expressed at approximately the 95% confidence level using a coverage factor of $k = 2$.



3. GENERAL INFORMATION

3.1 GENERAL DESCRIPTION OF EUT

EUT	Dual Radio Concurrent AP/CB
MODEL NO.	SC6000
FCC ID	RV7-SC6000
NOMINAL VOLTAGE	48Vdc (POE)
MODULATION TYPE	64QAM, 16QAM, QPSK, BPSK
MODULATION TECHNOLOGY	OFDM
TRANSFER RATE	54.0/ 48.0/ 36.0/ 24.0/ 18.0/ 12.0/ 9.0/ 6.0Mbps
FREQUENCY RANGE	5180~5240MHz
NUMBER OF CHANNEL	4
OUTPUT POWER	3.6mW
ANTENNA TYPE	Patch antenna with 15dBi gain
ANTENNA CONNECTER	MMCX
DATA CABLE	NA
I/O PORTS	RJ45
ASSOCIATED DEVICES	POE

NOTE:

- The EUT is a Dual Radio Concurrent AP/CB. The test data are separated into following test reports.

	Test Standard	Reference Report
WLAN 802.11a (5745~5825 MHz)	FCC Part 15, Subpart C (Section 15.247)	RF990806C19
WLAN 802.11a (5180~5240MHz)	FCC Part 15, Subpart E (Section 15.407)	RF990806C19-1

- The frequency bands used in this EUT are listed as follows:

Frequency Band (MHz)	5180~5240	5745~5825
802.11a	√	√

- The EUT uses following POE.

Model	NPE-7530G
Output power	48Vdc, 0.5A, 24W Max

- The EUT uses following POE & POE's adapter.

POE	
BRAND	NA
MODEL	NPE-7530G

POE's Adapter	
BRAND	Powertron
MODEL	PA1024-4T1
INPUT POWER	100-240Vac, 50-60Hz, 0.6A
OUTPUT POWER	48Vdc, 0.5A, 24W Max
POWER LINE	1.8 m non-shielded cable without core

- The above EUT information was declared by the manufacturer and for more detailed features description, please refer to the manufacturer's specifications or User's Manual.

3.2 DESCRIPTION OF TEST MODES

4 channels are provided for 802.11a:

CHANNEL	FREQUENCY
36	5180MHz
40	5200MHz
44	5220MHz
48	5240MHz

3.2.1 CONFIGURATION OF SYSTEM UNDER TEST

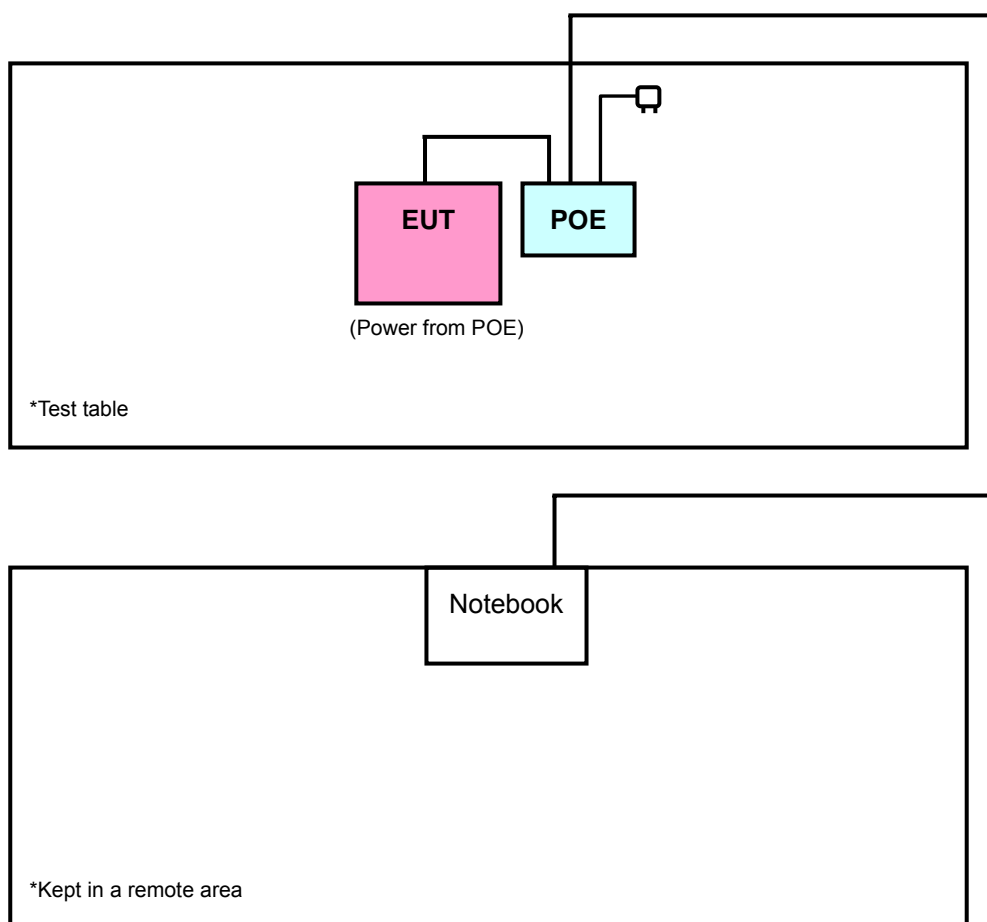



A D T

3.2.2 TEST MODE APPLICABILITY AND TESTED CHANNEL DETAIL

EUT CONFIGURE MODE	APPLICABLE TO				DESCRIPTION
	RE \geq 1G	RE<1G	PLC	APCM	
-	√	√	√	√	-

Where **RE \geq 1G**: Radiated Emission above 1GHz **RE<1G**: Radiated Emission below 1GHz
PLC: Power Line Conducted Emission **APCM**: Antenna Port Conducted Measurement

RADIATED EMISSION TEST (ABOVE 1GHz):

- Pre-Scan has been conducted to determine the worst-case mode from all possible combinations between available modulations, data rates, XYZ axis and antenna ports (if EUT with antenna diversity architecture).
- Following channel(s) was (were) selected for the final test as listed below.

MODE	AVAILABLE CHANNEL	TESTED CHANNEL	MODULATION TECHNOLOGY	MODULATION TYPE	DATA RATE (Mbps)	AXIS
802.11a	36 to 48	36, 40, 48	OFDM	BPSK	6.0	Z

RADIATED EMISSION TEST (BELOW 1GHz):

- Pre-Scan has been conducted to determine the worst-case mode from all possible combinations between available modulations, data rates, XYZ axis and antenna ports (if EUT with antenna diversity architecture).
- Following channel(s) was (were) selected for the final test as listed below.

MODE	AVAILABLE CHANNEL	TESTED CHANNEL	MODULATION TECHNOLOGY	MODULATION TYPE	DATA RATE (Mbps)	AXIS
802.11a	36 to 48	48	OFDM	BPSK	6.0	Z

POWER LINE CONDUCTED EMISSION TEST:

- Pre-Scan has been conducted to determine the worst-case mode from all possible combinations between available modulations, data rates and antenna ports (if EUT with antenna diversity architecture).
- Following channel(s) was (were) selected for the final test as listed below.

MODE	AVAILABLE CHANNEL	TESTED CHANNEL	MODULATION TECHNOLOGY	MODULATION TYPE	DATA RATE (Mbps)
802.11a	36 to 48	48	OFDM	BPSK	6.0

BANDEDGE MEASUREMENT:

- Pre-Scan has been conducted to determine the worst-case mode from all possible combinations between available modulations, data rates and antenna ports (if EUT with antenna diversity architecture).
- Following channel(s) was (were) selected for the final test as listed below.

MODE	AVAILABLE CHANNEL	TESTED CHANNEL	MODULATION TECHNOLOGY	MODULATION TYPE	DATA RATE (Mbps)
802.11a	36 to 48	36, 48	OFDM	BPSK	6.0

ANTENNA PORT CONDUCTED MEASUREMENT:

- This item includes all test value of each mode, but only includes spectrum plot of worst value of each mode.
- Pre-Scan has been conducted to determine the worst-case mode from all possible combinations between available modulations, data rates and antenna ports (if EUT with antenna diversity architecture).
- Following channel(s) was (were) selected for the final test as listed below.

MODE	AVAILABLE CHANNEL	TESTED CHANNEL	MODULATION TECHNOLOGY	MODULATION TYPE	DATA RATE (Mbps)
802.11a	36 to 48	36, 40, 48	OFDM	BPSK	6.0

TEST CONDITION:

APPLICABLE TO	ENVIRONMENTAL CONDITIONS	INPUT POWER	TESTED BY
RE \geq 1G	25deg. C, 65%RH, 1020 hPa	48Vdc	Brad Wu
RE $<$ 1G	26deg. C, 66%RH, 1008 hPa	48Vdc	Brad Wu
PLC	24deg. C, 62%RH, 1015 hPa	48Vdc	Peter Lin
APCM	26deg. C, 65%RH, 1020 hPa	48Vdc	Brad Wu

3.3 GENERAL DESCRIPTION OF APPLIED STANDARDS

The EUT is a RF Product. According to the specifications of the manufacturer, it must comply with the requirements of the following standards:

FCC Part 15, Subpart E (15.407)

ANSI C63.4-2003

All test items have been performed and recorded as per the above standards.

NOTE: The EUT is also considered as a kind of computer peripheral, because the connection to computer is necessary for typical use. It has been verified to comply with the requirements of FCC Part 15, Subpart B, Class B (DoC). The test report has been issued separately.

3.4 DESCRIPTION OF SUPPORT UNITS

The EUT has been tested as an independent unit together with other necessary accessories or support units. The following support units or accessories were used to form a representative test configuration during the tests.

NO.	PRODUCT	BRAND	MODEL NO.	SERIAL NO.	FCC ID
1	NOTEBOOK	HP	NC6000	CNU4110Y6Q	NA

NO.	SIGNAL CABLE DESCRIPTION OF THE ABOVE SUPPORT UNITS
1	10 m non-shielded RJ45 cable

NOTE:

1. All power cords of the above support units are non-shielded (1.8 m).
2. Item 1 acted as a communication partner to transfer data.

4. TEST TYPES AND RESULTS

4.1 RADIATED EMISSION MEASUREMENT

4.1.1 LIMITS OF RADIATED EMISSION MEASUREMENT

Emissions radiated outside of the specified bands, shall be according to the general radiated limits in 15.209 as following:

FREQUENCIES (MHz)	FIELD STRENGTH (microvolts/meter)	MEASUREMENT DISTANCE (meters)
0.009 ~ 0.490	2400/F(kHz)	300
0.490 ~ 1.705	24000/F(kHz)	30
1.705 ~ 30.0	30	30
30 ~ 88	100	3
88 ~ 216	150	3
216 ~ 960	200	3
Above 960	500	3

NOTE:

1. The lower limit shall apply at the transition frequencies.
2. Emission level (dBuV/m) = 20 log Emission level (uV/m).
3. As shown in 15.35(b), for frequencies above 1000MHz, the field strength limits are based on average detector, however, the peak field strength of any emission shall not exceed the maximum permitted average limits, specified above by more than 20dB under any condition of modulation.

4.1.2 LIMITS OF UNWANTED EMISSION OUT OF THE RESTRICTED BANDS

FREQUENCIES (MHz)	EIRP LIMIT (dBm)	EQUIVALENT FIELD STRENGTH AT 3m (dBμV/m) *NOTE 3
	PK	PK
5150 ~ 5250	-27	68.3

NOTE:

1. The following formula is used to convert the equipment isotropic radiated power (eirp) to field strength:

$$E = \frac{1000000\sqrt{30P}}{3} \mu\text{V/m, where P is the eirp (Watts).$$



4.1.3 TEST INSTRUMENTS

DESCRIPTION & MANUFACTURER	MODEL NO.	SERIAL NO.	DATE OF CALIBRATION	DUE DATE OF CALIBRATION
Test Receiver ROHDE & SCHWARZ	ESIB7	100188	Dec. 21, 2009	Dec. 20, 2010
Spectrum Analyzer ROHDE & SCHWARZ	FSP40	100269	Dec. 31, 2009	Dec. 30, 2010
BILOG Antenna SCHWARZBECK	VULB9168	9168-160	Apr. 27, 2010	Apr. 26, 2011
HORN Antenna SCHWARZBECK	9120D	9120D-405	Feb. 03, 2010	Feb. 02, 2011
HORN Antenna SCHWARZBECK	BBHA 9170	BBHA9170243	Dec. 25, 2009	Dec. 24, 2010
Preamplifier Agilent	8447D	2944A10633	Nov. 10, 2009	Nov. 09, 2010
Preamplifier Agilent	8449B	3008A01964	Nov. 09, 2009	Nov. 08, 2010
RF signal cable HUBER+SUHNNER	SUCOFLEX 104	238141/4	May 14, 2010	May 13, 2011
RF signal cable HUBER+SUHNNER	SUCOFLEX 104	12738/6	May 14, 2010	May 13, 2011
Software ADT.	ADT_Radiated_ V7.6.15.9.2	NA	NA	NA
Antenna Tower inn-co GmbH	MA 4000	013303	NA	NA
Antenna Tower Controller inn-co GmbH	CO2000	017303	NA	NA
Turn Table ADT.	TT100.	TT93021703	NA	NA
Turn Table Controller ADT.	SC100.	SC93021703	NA	NA
26GHz ~ 40GHz Amplifier	EM26400	07026401	Aug. 25, 2010	Aug. 24, 2011

- NOTE:**
1. The calibration interval of the above test instruments is 12 months and the calibrations are traceable to NML/ROC and NIST/USA.
 2. The test was performed in HwaYa Chamber 3.
 3. The horn antenna and HP preamplifier (model: 8449B) are used only for the measurement of emission frequency above 1GHz if tested.
 4. The FCC Site Registration No. is 988962.
 5. The IC Site Registration No. is IC 7450F-3.

4.1.4 TEST PROCEDURES

- a. The EUT was placed on the top of a rotating table 0.8 meters above the ground at a 3 meter semi-anechoic chamber. The table was rotated 360 degrees to determine the position of the highest radiation.
- b. The EUT was set 3 meters away from the interference-receiving antenna, which was mounted on the top of a variable-height antenna tower.
- c. The antenna is a broadband antenna, and its height is varied from one meter to four meters above the ground to determine the maximum value of the field strength. Both horizontal and vertical polarizations of the antenna are set to make the measurement.
- d. For each suspected emission, the EUT was arranged to its worst case and then the antenna was tuned to heights from 1 meter to 4 meters and the rotatable table was turned from 0 degrees to 360 degrees to find the maximum reading.
- e. The test-receiver system was set to Peak Detect Function and Specified Bandwidth with Maximum Hold Mode.
- f. If the emission level of the EUT in peak mode was 10dB lower than the limit specified, then testing could be stopped and the peak values of the EUT would be reported. Otherwise the emissions that did not have 10dB margin would be re-tested one by one using peak, quasi-peak or average method as specified and then reported in a data sheet.

NOTE:

1. The resolution bandwidth and video bandwidth of test receiver/spectrum analyzer is 120kHz for Peak detection (PK) and Quasi-peak detection (QP) at frequency below 1GHz.
2. The resolution bandwidth of test receiver/spectrum analyzer is 1MHz and video bandwidth is 3MHz for Peak detection at frequency above 1GHz.
3. The resolution bandwidth of test receiver/spectrum analyzer is 1MHz and the video bandwidth is 10Hz for Average detection (AV) at frequency above 1GHz.
4. All modes of operation were investigated and the worst-case emissions are reported.

4.1.5 DEVIATION FROM TEST STANDARD

No deviation.

4.1.6 TEST SETUP

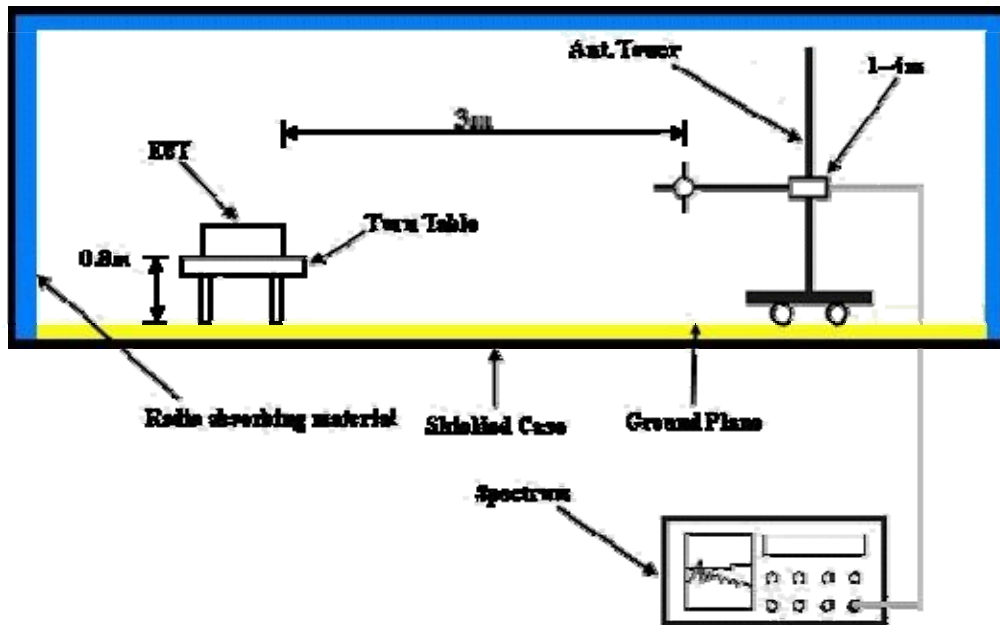

For the actual test configuration, please refer to the attached file (Test Setup Photo).

4.1.7 EUT OPERATING CONDITION

- a. Placed the EUT on the testing table.
- b. Prepared the notebook computer and placed it outside of testing area to act as communication partner for EUT.
- c. The EUT ran a test program (provided by manufacturer) to enable all functions under transmission condition continuously at specific channel frequency.



4.1.8 TEST RESULTS

802.11a

EUT TEST CONDITION		MEASUREMENT DETAIL	
CHANNEL	Channel 36	FREQUENCY RANGE	1 ~ 40GHz
INPUT POWER (SYSTEM)	120Vac, 60 Hz	DETECTOR FUNCTION	Peak (PK) Average (AV)
ENVIRONMENTAL CONDITIONS	25deg. C, 65%RH 1020 hPa	TESTED BY	Brad Wu

ANTENNA POLARITY & TEST DISTANCE: HORIZONTAL AT 3 M								
NO.	FREQ. (MHz)	EMISSION LEVEL (dBuV/m)	LIMIT (dBuV/m)	MARGIN (dB)	ANTENNA HEIGHT (m)	TABLE ANGLE (Degree)	RAW VALUE (dBuV)	CORRECTION FACTOR (dB/m)
1	4800.00	46.7 PK	74.0	-27.3	1.01 H	25	10.00	36.70
2	4800.00	33.5 AV	54.0	-20.5	1.01 H	25	-3.20	36.70
3	5120.00	48.3 PK	74.0	-25.7	1.09 H	251	10.90	37.40
4	5120.00	34.5 AV	54.0	-19.5	1.09 H	251	-2.90	37.40
5	5150.00	46.9 PK	74.0	-27.1	1.12 H	179	9.50	37.40
6	5150.00	34.3 AV	54.0	-19.7	1.12 H	179	-3.10	37.40
7	*5180.00	99.1 PK			1.12 H	179	61.70	37.40
8	*5180.00	87.5 AV			1.12 H	179	50.10	37.40
9	#10360.00	58.0 PK	68.3	-10.3	1.00 H	182	10.30	47.70
ANTENNA POLARITY & TEST DISTANCE: VERTICAL AT 3 M								
NO.	FREQ. (MHz)	EMISSION LEVEL (dBuV/m)	LIMIT (dBuV/m)	MARGIN (dB)	ANTENNA HEIGHT (m)	TABLE ANGLE (Degree)	RAW VALUE (dBuV)	CORRECTION FACTOR (dB/m)
1	4800.00	48.5 PK	74.0	-25.5	1.00 V	202	11.80	36.70
2	4800.00	37.2 AV	54.0	-16.8	1.00 V	202	0.50	36.70
3	5120.00	55.7 PK	74.0	-18.3	1.12 V	203	18.30	37.40
4	5120.00	45.8 AV	54.0	-8.2	1.12 V	203	8.40	37.40
5	5150.00	55.2 PK	74.0	-18.8	1.00 V	201	17.80	37.40
6	5150.00	44.0 AV	54.0	-10.0	1.00 V	201	6.60	37.40
7	*5180.00	115.4 PK			1.00 V	202	78.00	37.40
8	*5180.00	104.3 AV			1.00 V	202	66.90	37.40
9	#10360.00	58.3 PK	68.3	-10.0	1.00 V	20	10.60	47.70

- REMARKS:**
1. Emission level (dBuV/m) = Raw Value (dBuV) + Correction Factor (dB/m).
 2. Correction Factor (dB/m) = Antenna Factor (dB/m) + Cable Factor (dB).
 3. The other emission levels were very low against the limit.
 4. Margin value = Emission level – Limit value.
 5. “ * “: Fundamental frequency.
 6. “#”:The radiated frequency is out the restricted band.



A D T

EUT TEST CONDITION		MEASUREMENT DETAIL	
CHANNEL	Channel 40	FREQUENCY RANGE	1 ~ 40GHz
INPUT POWER (SYSTEM)	120Vac, 60 Hz	DETECTOR FUNCTION	Peak (PK) Average (AV)
ENVIRONMENTAL CONDITIONS	25deg. C, 65%RH 1020 hPa	TESTED BY	Brad Wu

ANTENNA POLARITY & TEST DISTANCE: HORIZONTAL AT 3 M								
NO.	FREQ. (MHz)	EMISSION LEVEL (dBuV/m)	LIMIT (dBuV/m)	MARGIN (dB)	ANTENNA HEIGHT (m)	TABLE ANGLE (Degree)	RAW VALUE (dBuV)	CORRECTION FACTOR (dB/m)
1	4800.00	46.9 PK	74.0	-27.1	1.02 H	31	10.20	36.70
2	4800.00	33.6 AV	54.0	-20.4	1.02 H	31	-3.10	36.70
3	5120.00	48.6 PK	74.0	-25.4	1.10 H	250	11.20	37.40
4	5120.00	34.8 AV	54.0	-19.2	1.10 H	250	-2.60	37.40
5	*5200.00	98.8 PK			1.13 H	180	61.40	37.40
6	*5200.00	87.2 AV			1.13 H	180	49.80	37.40
7	#10400.00	58.4 PK	68.3	-9.9	1.05 H	195	10.50	47.90
ANTENNA POLARITY & TEST DISTANCE: VERTICAL AT 3 M								
NO.	FREQ. (MHz)	EMISSION LEVEL (dBuV/m)	LIMIT (dBuV/m)	MARGIN (dB)	ANTENNA HEIGHT (m)	TABLE ANGLE (Degree)	RAW VALUE (dBuV)	CORRECTION FACTOR (dB/m)
1	4800.00	48.8 PK	74.0	-25.2	1.05 V	203	12.10	36.70
2	4800.00	37.5 AV	54.0	-16.5	1.05 V	203	0.80	36.70
3	5120.00	56.0 PK	74.0	-18.0	1.10 V	205	18.60	37.40
4	5120.00	46.1 AV	54.0	-7.9	1.10 V	205	8.70	37.40
5	*5200.00	115.1 PK			1.00 V	202	77.70	37.40
6	*5200.00	103.9 AV			1.00 V	202	66.50	37.40
7	#10400.00	58.6 PK	68.3	-9.7	1.00 V	180	10.70	47.90

- REMARKS:**
1. Emission level (dBuV/m) = Raw Value (dBuV) + Correction Factor (dB/m).
 2. Correction Factor (dB/m) = Antenna Factor (dB/m) + Cable Factor (dB).
 3. The other emission levels were very low against the limit.
 4. Margin value = Emission level – Limit value.
 5. “ * “: Fundamental frequency.
 6. “#”:The radiated frequency is out the restricted band.



A D T

EUT TEST CONDITION		MEASUREMENT DETAIL	
CHANNEL	Channel 48	FREQUENCY RANGE	1 ~ 40GHz
INPUT POWER (SYSTEM)	120Vac, 60 Hz	DETECTOR FUNCTION	Peak (PK) Average (AV)
ENVIRONMENTAL CONDITIONS	25deg. C, 65%RH 1020 hPa	TESTED BY	Brad Wu

ANTENNA POLARITY & TEST DISTANCE: HORIZONTAL AT 3 M								
NO.	FREQ. (MHz)	EMISSION LEVEL (dBuV/m)	LIMIT (dBuV/m)	MARGIN (dB)	ANTENNA HEIGHT (m)	TABLE ANGLE (Degree)	RAW VALUE (dBuV)	CORRECTION FACTOR (dB/m)
1	4800.00	46.5 PK	74.0	-27.5	1.05 H	31	9.80	36.70
2	4800.00	33.2 AV	54.0	-20.8	1.05 H	31	-3.50	36.70
3	5120.00	48.0 PK	74.0	-26.0	1.08 H	245	10.60	37.40
4	5120.00	34.1 AV	54.0	-19.9	1.08 H	245	-3.30	37.40
5	*5240.00	99.0 PK			1.11 H	252	61.40	37.60
6	*5240.00	87.2 AV			1.11 H	252	49.60	37.60
7	5350.00	39.4 PK	74.0	-34.6	1.11 H	252	1.70	37.70
8	5350.00	27.5 AV	54.0	-26.5	1.11 H	252	-10.20	37.70
9	#10480.00	58.6 PK	68.3	-9.7	1.04 H	231	10.60	48.00
ANTENNA POLARITY & TEST DISTANCE: VERTICAL AT 3 M								
NO.	FREQ. (MHz)	EMISSION LEVEL (dBuV/m)	LIMIT (dBuV/m)	MARGIN (dB)	ANTENNA HEIGHT (m)	TABLE ANGLE (Degree)	RAW VALUE (dBuV)	CORRECTION FACTOR (dB/m)
1	4800.00	48.9 PK	74.0	-25.1	1.06 V	204	12.20	36.70
2	4800.00	37.6 AV	54.0	-16.4	1.06 V	204	0.90	36.70
3	5120.00	55.8 PK	74.0	-18.2	1.09 V	204	18.40	37.40
4	5120.00	45.9 AV	54.0	-8.1	1.09 V	204	8.50	37.40
5	*5240.00	115.3 PK			1.00 V	201	77.70	37.60
6	*5240.00	104.1 AV			1.00 V	201	66.50	37.60
7	5350.00	49.1 PK	74.0	-24.9	1.00 V	200	11.40	37.70
8	5350.00	36.9 AV	54.0	-17.1	1.00 V	200	-0.80	37.70
9	#10480.00	58.9 PK	68.3	-9.4	1.00 V	226	10.90	48.00

- REMARKS:**
1. Emission level (dBuV/m) = Raw Value (dBuV) + Correction Factor (dB/m).
 2. Correction Factor (dB/m) = Antenna Factor (dB/m) + Cable Factor (dB).
 3. The other emission levels were very low against the limit.
 4. Margin value = Emission level – Limit value.
 5. “ * “: Fundamental frequency.
 6. “#”: The radiated frequency is out the restricted band.

BELOW 1GHz WORST-CASE DATA : 802.11a

EUT TEST CONDITION		MEASUREMENT DETAIL	
CHANNEL	Channel 48	FREQUENCY RANGE	Below 1000MHz
INPUT POWER (SYSTEM)	120Vac, 60 Hz	DETECTOR FUNCTION	Quasi-Peak
ENVIRONMENTAL CONDITIONS	26deg. C, 65%RH 1008 hPa	TESTED BY	Brad Wu

ANTENNA POLARITY & TEST DISTANCE: HORIZONTAL AT 3 M								
NO.	FREQ. (MHz)	EMISSION LEVEL (dBuV/m)	LIMIT (dBuV/m)	MARGIN (dB)	ANTENNA HEIGHT (m)	TABLE ANGLE (Degree)	RAW VALUE (dBuV)	CORRECTION FACTOR (dB/m)
1	160.17	36.6 QP	43.5	-6.9	1.25 H	73	22.00	14.60
2	249.60	40.1 QP	46.0	-5.9	1.00 H	70	27.30	12.80
3	339.04	39.9 QP	46.0	-6.1	1.00 H	202	24.20	15.70
4	566.52	32.1 QP	46.0	-13.9	1.25 H	322	10.80	21.30
5	700.68	38.0 QP	46.0	-8.0	1.25 H	37	14.40	23.60
6	850.39	37.1 QP	46.0	-8.9	2.00 H	85	11.90	25.20
ANTENNA POLARITY & TEST DISTANCE: VERTICAL AT 3 M								
NO.	FREQ. (MHz)	EMISSION LEVEL (dBuV/m)	LIMIT (dBuV/m)	MARGIN (dB)	ANTENNA HEIGHT (m)	TABLE ANGLE (Degree)	RAW VALUE (dBuV)	CORRECTION FACTOR (dB/m)
1	37.68	36.2 QP	40.0	-3.8	1.25 V	94	22.70	13.50
2	107.67	38.1 QP	43.5	-5.4	1.00 V	166	27.10	11.00
3	339.04	44.7 QP	46.0	-1.3	1.25 V	169	29.00	15.70
4	681.24	39.9 QP	46.0	-6.1	1.25 V	160	16.60	23.30
5	799.84	40.9 QP	46.0	-5.1	1.50 V	58	16.30	24.60
6	834.84	43.3 QP	46.0	-2.7	1.00 V	157	18.20	25.10

- REMARKS:**
1. Emission level (dBuV/m) = Raw Value (dBuV) + Correction Factor (dB/m).
 2. Correction Factor (dB/m) = Antenna Factor (dB/m) + Cable Factor (dB).
 3. The other emission levels were very low against the limit.
 4. Margin value = Emission level – Limit value.

4.2 CONDUCTED EMISSION MEASUREMENT

4.2.1 LIMITS OF CONDUCTED EMISSION MEASUREMENT

FREQUENCY OF EMISSION (MHz)	CONDUCTED LIMIT (dB μ V)	
	Quasi-peak	Average
0.15 ~ 0.5	66 to 56	56 to 46
0.5 ~ 5	56	46
5 ~ 30	60	50

- NOTE:** 1. The lower limit shall apply at the transition frequencies.
2. The limit decreases in line with the logarithm of the frequency in the range of 0.15 to 0.50MHz.
3. All emanations from a class A/B digital device or system, including any network of conductors and apparatus connected thereto, shall not exceed the level of field strengths specified above.

4.2.2 TEST INSTRUMENTS

DESCRIPTION & MANUFACTURER	MODEL NO.	SERIAL NO.	DATE OF CALIBRATION	DUE DATE OF CALIBRATION
Test Receiver ROHDE & SCHWARZ	ESCS30	100291	Dec. 16, 2009	Dec. 15, 2010
RF signal cable Woken	5D-FB	Cable-HYC01-01	Nov. 12, 2009	Nov. 11, 2010
LISN ROHDE & SCHWARZ	ESH3-Z5	100312	Jun. 28, 2010	Jun. 27, 2011
LISN ROHDE & SCHWARZ	ESH3-Z5	835239/001	Feb. 10, 2010	Feb. 09, 2011
Software ADT	ADT_Cond_ V7.3.7	NA	NA	NA

- NOTE:** 1. The calibration interval of the above test instruments is 12 months and the calibrations are traceable to NML/ROC and NIST/USA.
2. The test was performed in HwaYa Shielded Room 1.
3. The VCCI Site Registration No. is C-2040.

4.2.3 TEST PROCEDURES

- a. The EUT was placed 0.4 meters from the conducting wall of the shielded room with EUT being connected to the power mains through a line impedance stabilization network (LISN). Other support units were connected to the power mains through another LISN. The two LISNs provide 50 ohm/ 50uH of coupling impedance for the measuring instrument.
- b. Both lines of the power mains connected to the EUT were checked for maximum conducted interference.
- c. The frequency range from 150kHz to 30MHz was searched. Emission levels under (Limit - 20dB) was not recorded.

4.2.4 DEVIATION FROM TEST STANDARD

No deviation.

4.2.5 TEST SETUP

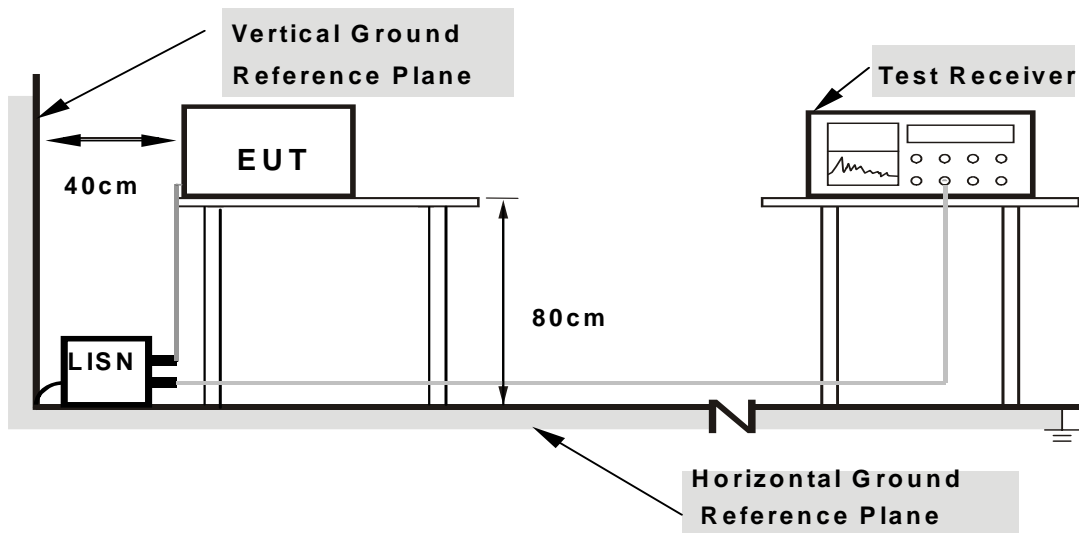

- Note:**
1. Support units were connected to second LISN.
 2. Both of LISNs (AMN) are 80 cm from EUT and at least 80 from other units and other metal planes

For the actual test configuration, please refer to the attached file (Test Setup Photo).

4.2.6 EUT OPERATING CONDITIONS

Same as item 4.1.6.

4.2.7 TEST RESULTS

CONDUCTED WORST-CASE DATA : 802.11a

PHASE	Line 1	6dB BANDWIDTH	9kHz
-------	--------	---------------	------

No	Freq. [MHz]	Corr. Factor (dB)	Reading Value [dB (uV)]		Emission Level [dB (uV)]		Limit [dB (uV)]		Margin (dB)	
			Q.P.	AV.	Q.P.	AV.	Q.P.	AV.	Q.P.	AV.
1	0.150	0.12	62.81	46.95	62.93	47.07	66.00	56.00	-3.07	-8.93
2	0.180	0.11	58.59	47.01	58.70	47.12	64.49	54.49	-5.79	-7.37
3	0.227	0.11	51.87	-	51.98	-	62.57	52.57	-10.58	-
4	0.513	0.14	52.89	44.66	53.03	44.80	56.00	46.00	-2.97	-1.20
5	0.810	0.16	45.78	-	45.94	-	56.00	46.00	-10.06	-
6	1.137	0.19	46.96	38.36	47.15	38.55	56.00	46.00	-8.85	-7.45
7	1.527	0.22	46.68	39.32	46.90	39.54	56.00	46.00	-9.10	-6.46
8	1.770	0.23	47.68	40.10	47.91	40.33	56.00	46.00	-8.09	-5.67
9	2.129	0.26	48.76	40.89	49.02	41.15	56.00	46.00	-6.98	-4.85
10	2.445	0.27	48.41	41.32	48.68	41.59	56.00	46.00	-7.32	-4.41
11	3.051	0.30	46.95	39.31	47.25	39.61	56.00	46.00	-8.75	-6.39
12	4.457	0.37	47.73	39.93	48.10	40.30	56.00	46.00	-7.90	-5.70
13	5.840	0.44	46.91	-	47.35	-	60.00	50.00	-12.65	-
14	7.918	0.54	47.00	-	47.54	-	60.00	50.00	-12.46	-
15	12.438	0.84	54.81	48.08	55.65	48.92	60.00	50.00	-4.35	-1.08

- REMARKS:**
1. Q.P. and AV. are abbreviations of quasi-peak and average individually.
 2. "-": The Quasi-peak reading value also meets average limit and measurement with the average detector is unnecessary.
 3. The emission levels of other frequencies were very low against the limit.
 4. Margin value = Emission level - Limit value
 5. Correction factor = Insertion loss + Cable loss
 6. Emission Level = Correction Factor + Reading Value.

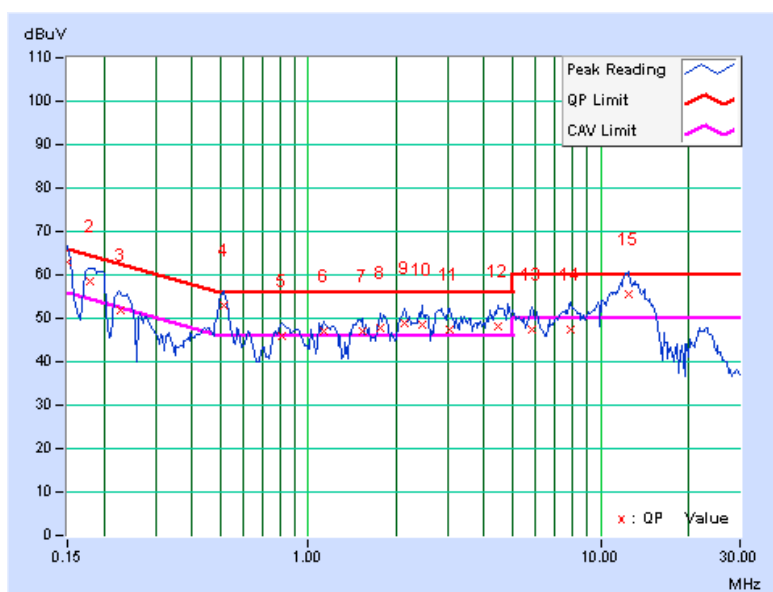



A D T

PHASE	Line 2	6dB BANDWIDTH	9kHz
-------	--------	---------------	------

No	Freq. [MHz]	Corr. Factor (dB)	Reading Value		Emission Level		Limit		Margin	
			[dB (uV)]		[dB (uV)]		[dB (uV)]		(dB)	
			Q.P.	AV.	Q.P.	AV.	Q.P.	AV.	Q.P.	AV.
1	0.150	0.10	61.46	46.10	61.56	46.20	66.00	56.00	-4.44	-9.80
2	0.181	0.10	57.79	47.74	57.89	47.84	64.43	54.43	-6.54	-6.59
3	0.228	0.10	52.68	43.51	52.78	43.61	62.52	52.52	-9.74	-8.91
4	0.513	0.13	53.29	44.74	53.42	44.87	56.00	46.00	-2.58	-1.13
5	0.806	0.15	46.47	39.61	46.62	39.76	56.00	46.00	-9.38	-6.24
6	1.141	0.18	46.72	39.06	46.90	39.24	56.00	46.00	-9.10	-6.76
7	1.488	0.20	46.52	38.71	46.72	38.91	56.00	46.00	-9.28	-7.09
8	1.813	0.23	47.19	39.86	47.42	40.09	56.00	46.00	-8.58	-5.91
9	2.078	0.24	47.41	38.82	47.65	39.06	56.00	46.00	-8.35	-6.94
10	2.430	0.26	47.13	39.27	47.39	39.53	56.00	46.00	-8.61	-6.47
11	2.844	0.27	46.47	39.16	46.74	39.43	56.00	46.00	-9.26	-6.57
12	3.891	0.32	43.92	-	44.24	-	56.00	46.00	-11.76	-
13	4.559	0.34	45.83	36.79	46.17	37.13	56.00	46.00	-9.83	-8.87
14	12.137	0.71	49.38	43.30	50.09	44.01	60.00	50.00	-9.91	-5.99

- REMARKS:**
1. Q.P. and AV. are abbreviations of quasi-peak and average individually.
 2. "-": The Quasi-peak reading value also meets average limit and measurement with the average detector is unnecessary.
 3. The emission levels of other frequencies were very low against the limit.
 4. Margin value = Emission level - Limit value
 5. Correction factor = Insertion loss + Cable loss
 6. Emission Level = Correction Factor + Reading Value.

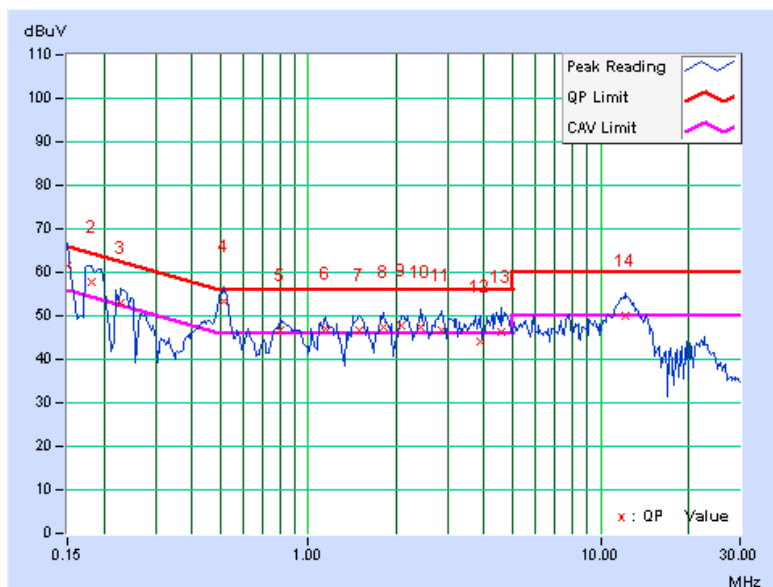

4.3 MAXIMUM CONDUCTED OUTPUT POWER MEASUREMENT

4.3.1 LIMITS OF MAXIMUM CONDUCTED OUTPUT POWER MEASUREMENT

FREQUENCY BAND	LIMIT
5.150 ~ 5.250GHz	The lesser of 50mW (17dBm) or 4dBm + 10logB

NOTE: Where B is the 26dB emission bandwidth in MHz.

4.3.2 TEST INSTRUMENTS

FOR POWER OUTPUT MEASUREMENT

DESCRIPTION & MANUFACTURER	MODEL NO.	SERIAL NO.	DATE OF CALIBRATION	DUE DATE OF CALIBRATION
High Speed Peak Power Meter	ML2495A	0842014	Apr. 21, 2010	Apr. 20, 2011
Power Sensor	MA2411B	0738404	Apr. 21, 2010	Apr. 20, 2011

Note:

1. The calibration interval of the above test instruments is 12 months and the calibrations are traceable to NML/ROC and NIST/USA.
2. Measurement Bandwidth of ML2495A is 65MHz greater than 26dB bandwidth of emission.

FOR 26dB OCCUPIED BANDWIDTH

DESCRIPTION & MANUFACTURER	MODEL NO.	SERIAL NO.	DATE OF CALIBRATION	DUE DATE OF CALIBRATION
R&S SPECTRUM ANALYZER	FSP40	100039	Jan. 11, 2010	Jan. 10, 2011

NOTE: The calibration interval of the above test instruments is 12 months and the calibrations are traceable to NML/ROC and NIST/USA.

4.3.3 TEST PROCEDURE

FOR POWER OUTPUT MEASUREMENT

A power sensor was used on the output port of the EUT. A power meter was used to read the response of the power sensor. Record the power level.

FOR 26dB OCCUPIED BANDWIDTH

The transmitter output was connected to the spectrum analyzer through an attenuator. The bandwidth of the fundamental frequency was measured by spectrum analyzer with 300kHz RBW and 1MHz VBW. The 26dB bandwidth is defined as the total spectrum the power of which is higher than peak power minus 26dB.

4.3.4 DEVIATION FROM TEST STANDARD

No deviation.

4.3.5 TEST SETUP

FOR POWER OUTPUT MEASUREMENT

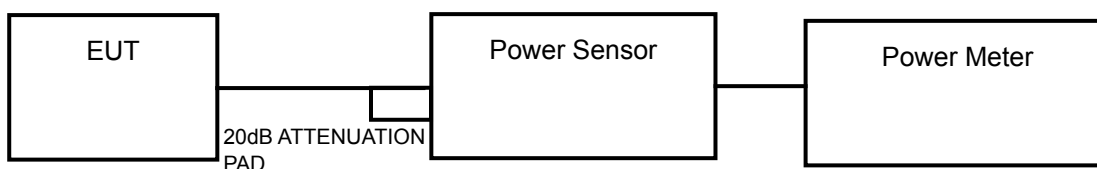

FOR 26dB OCCUPIED BANDWIDTH

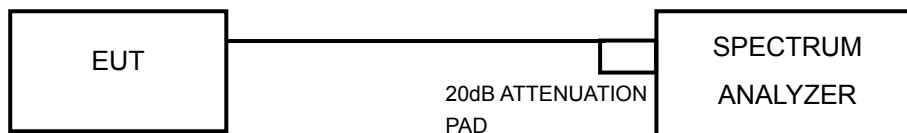

4.3.6 EUT OPERATING CONDITIONS

The software provided by client to enable the EUT under transmission condition continuously at specific channel frequencies individually.

4.3.7 TEST RESULTS

POWER OUTPUT: 802.11a

CHAN.	CHAN. FREQ. (MHz)	OUTPUT POWER (dBm)	OUTPUT POWER (mW)	POWER LIMIT (dBm)	PASS / FAIL
36	5180	5.1	3.2	8	PASS
40	5200	5.2	3.3	8	PASS
48	5240	5.6	3.6	8	PASS

NOTE: According to 15.407 (a) (1) (2) (3), the maximum antenna gain 15dBi is higher than 6dBi, so the limit of peak power spectral density shall be reduced by 9dB.



A D T

26dB OCCUPIED BANDWIDTH: 802.11a

CHANNEL	CHANNEL FREQUENCY (MHz)	26dBc OCCUPIED BANDWIDTH (MHz)	PASS / FAIL
36	5180	24.72	PASS
40	5200	23.85	PASS
48	5240	24.38	PASS

CH 36

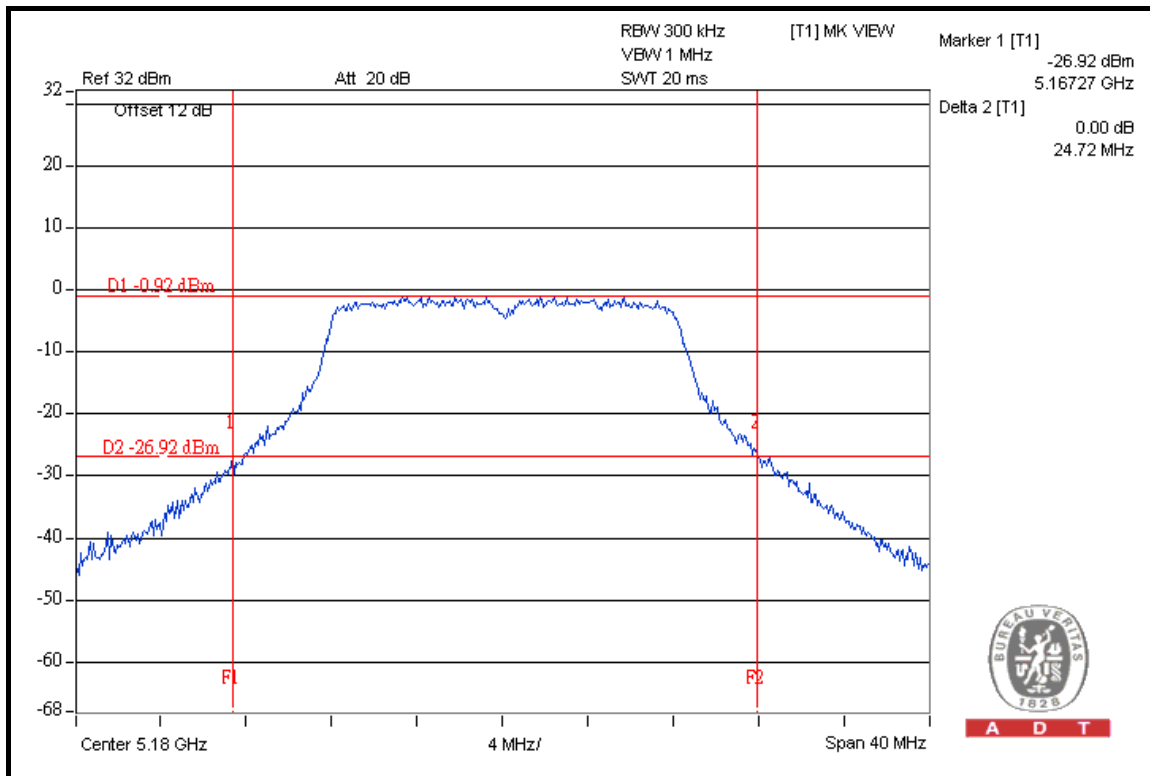

4.4 PEAK POWER EXCURSION MEASUREMENT

4.4.1 LIMITS OF PEAK POWER EXCURSION MEASUREMENT

FREQUENCY BAND	LIMIT
5.150 ~ 5.250GHz	13dB

4.4.2 TEST INSTRUMENTS

DESCRIPTION & MANUFACTURER	MODEL NO.	SERIAL NO.	DATE OF CALIBRATION	DUE DATE OF CALIBRATION
R&S SPECTRUM ANALYZER	FSP40	100039	Jan. 11, 2010	Jan. 10, 2011

NOTE: The calibration interval of the above test instruments is 12 months and the calibrations are traceable to NML/ROC and NIST/USA.

4.4.3 TEST PROCEDURE

- a. The transmitter output was connected to the spectrum analyzer.
- b. Set the spectrum bandwidth span to view the entire spectrum.
- c. Using peak detector and Max-hold function for Trace 1 (RB = 1MHz, VB = 3MHz) and 2 (RB = 1MHz, VB = 300kHz).
- d. The differences between Trace1 and Trace 2 in any 1MHz band at f1 to f2 range were recorded and showed to another trace.

4.4.4 DEVIATION FROM TEST STANDARD

No deviation.

4.4.5 TEST SETUP

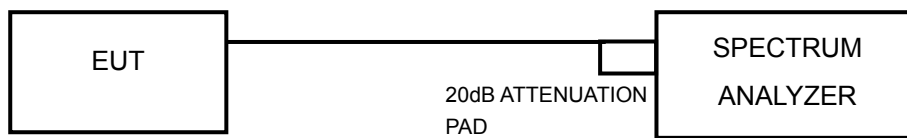

4.4.6 EUT OPERATING CONDITIONS

The software provided by client to enable the EUT under transmission condition continuously at specific channel frequencies individually.

4.4.7 TEST RESULTS

802.11a

CHANNEL	CHANNEL FREQUENCY (MHz)	PEAK POWER EXCURSION (dB)	PEAK to AVERAGE EXCURSION LIMIT (dB)	PASS/FAIL
36	5180	8.48	13	PASS
40	5200	8.94	13	PASS
48	5240	8.11	13	PASS



A D T

CH 40

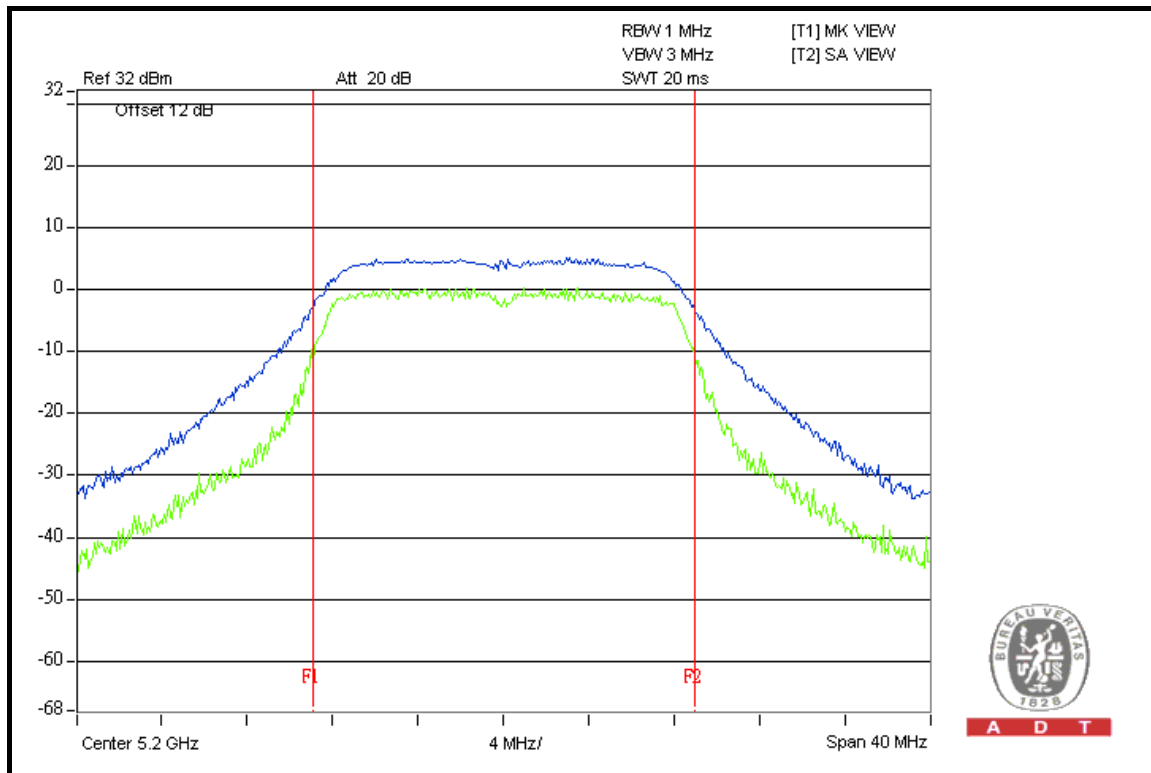

A D T

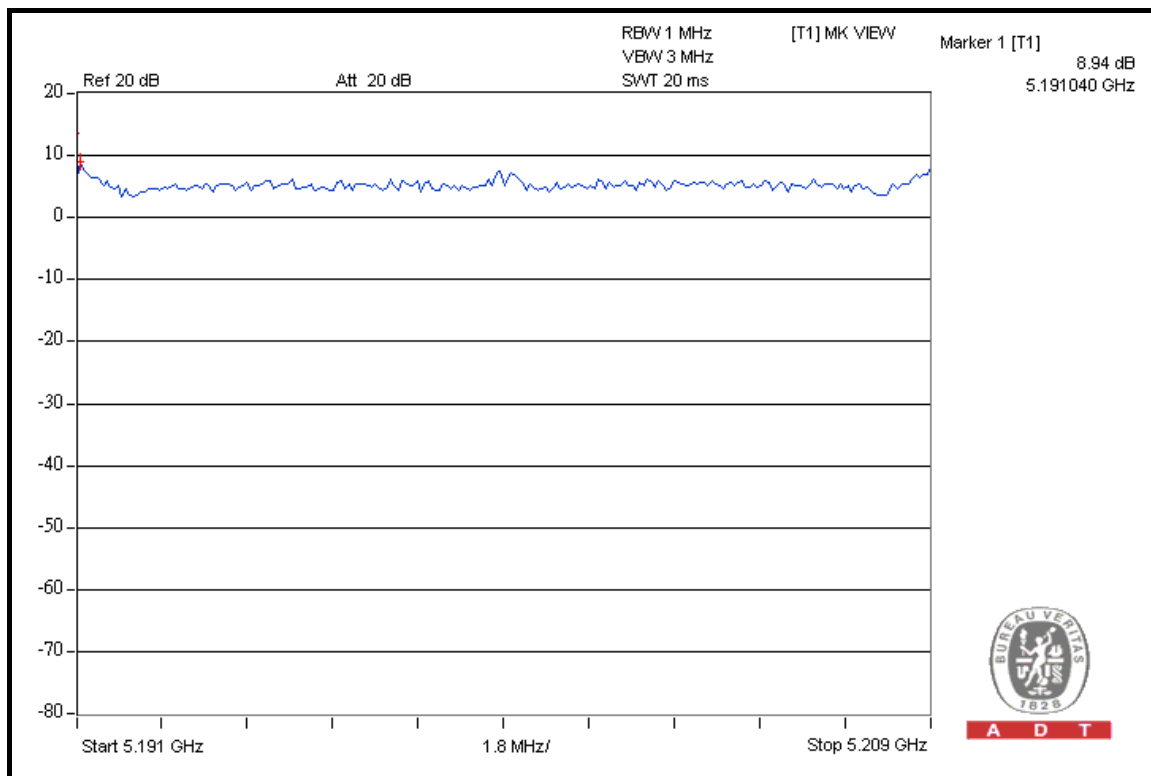

A D T



4.5 PEAK POWER SPECTRAL DENSITY MEASUREMENT

4.5.1 LIMITS OF PEAK POWER SPECTRAL DENSITY MEASUREMENT

FREQUENCY BAND	LIMIT
5.150 ~ 5.250GHz	4dBm

4.5.2 TEST INSTRUMENTS

DESCRIPTION & MANUFACTURER	MODEL NO.	SERIAL NO.	DATE OF CALIBRATION	DUE DATE OF CALIBRATION
R&S SPECTRUM ANALYZER	FSP40	100039	Jan. 11, 2010	Jan. 10, 2011

NOTE: The calibration interval of the above test instruments is 12 months and the calibrations are traceable to NML/ROC and NIST/USA.

4.5.3 TEST PROCEDURES

- a. The transmitter output was connected to the spectrum analyzer.
- b. Set RBW = 1MHz, VBW = 3MHz. The PPSD is the highest level found across the emission in any 1MHz band.

4.5.4 DEVIATION FROM TEST STANDARD

No deviation.

4.5.5 TEST SETUP

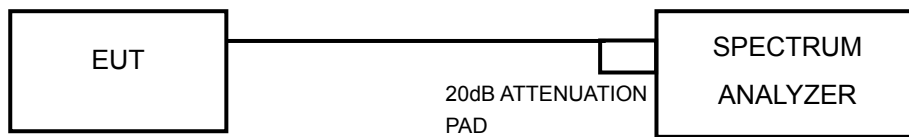

4.5.6 EUT OPERATING CONDITIONS

Same as 4.3.6.

4.5.7 TEST RESULTS

802.11a

CHAN.	CHAN. FREQ. (MHz)	RF POWER LEVEL IN 1MHz BW (dBm)	MAX. LIMIT (dBm)	PASS / FAIL
36	5180	-5.43	-5	PASS
40	5200	-5.68	-5	PASS
48	5240	-5.45	-5	PASS

NOTE: According to 15.407 (a) (1) (2) (3), the maximum antenna gain 15dBi is higher than 6dBi, so the limit of peak power spectral density shall be reduced by 9dB.

CH 36

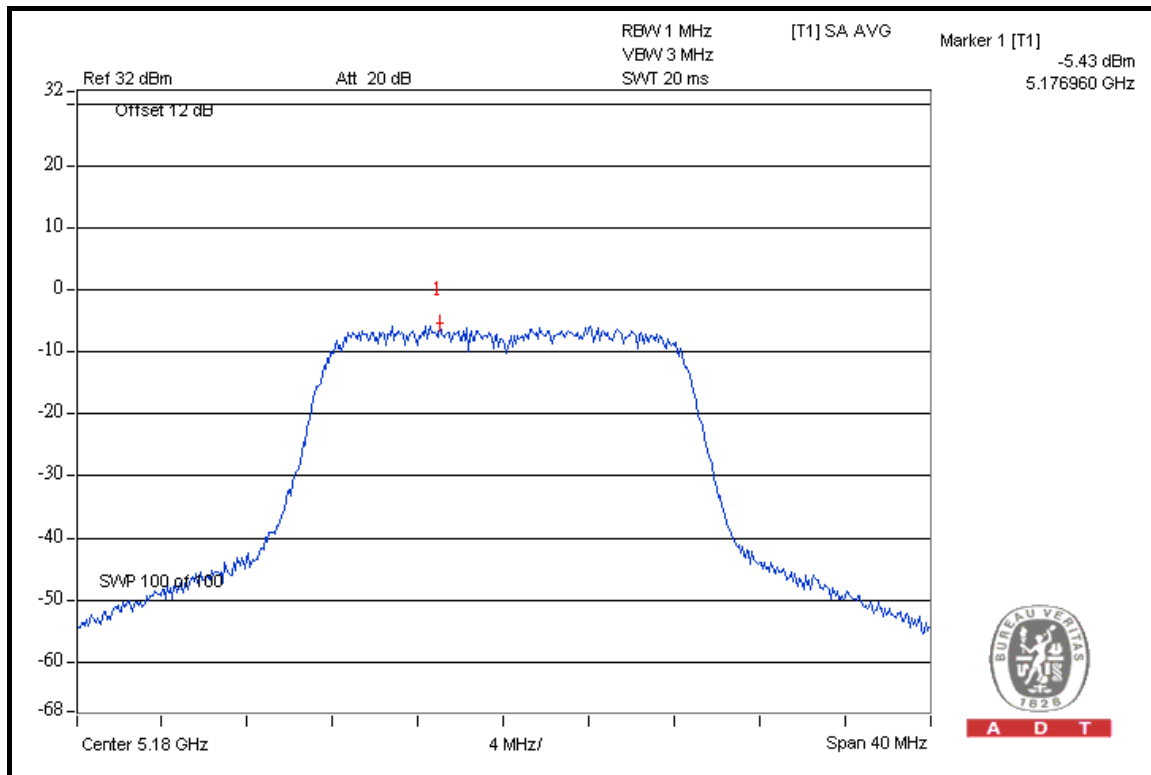

4.6 FREQUENCY STABILITY

4.6.1 LIMITS OF FREQUENCY STABILITY MEASUREMENT

The frequency tolerance of the carrier signal shall be maintained within +/- 0.02% of the operating frequency over a temperature variation of -30 degrees to 50 degrees C at normal supply voltage, and for a variation in the primary supply voltage from 85% to 115% of the rated supply voltage at a temperature of 20 degrees C.

4.6.2 TEST INSTRUMENTS

DESCRIPTION & MANUFACTURER	MODEL NO.	SERIAL NO.	DATE OF CALIBRATION	DUE DATE OF CALIBRATION
R&S SPECTRUM ANALYZER	FSP40	100039	Jan. 11, 2010	Jan. 10, 2011
WIT STANDARD TEMPERATURE AND HUMIDITY CHAMBER	TH-4S-C	W981030	Jun. 28, 2010	Jun. 27, 2011

NOTE: The calibration interval of the above test instruments is 12 months and the calibrations are traceable to NML/ROC and NIST/USA.

4.6.3 TEST PROCEDURE

- a. The EUT was placed inside the environmental test chamber and powered by nominal DC voltage.
- b. Turn the EUT on and couple its output to a spectrum analyzer.
- c. Turn the EUT off and set the chamber to the highest temperature specified.
- d. Allow sufficient time (approximately 30 min) for the temperature of the chamber to stabilize, turn the EUT on and measure the operating frequency after 2, 5, and 10 minutes.
- e. Repeat step b and c with the temperature chamber set to the lowest temperature.
- f. The test chamber was allowed to stabilize at +20 degree C for a minimum of 30 minutes. The supply voltage was then adjusted on the EUT from 85% to 115% and the frequency record.

4.6.4 DEVIATION FROM TEST STANDARD

No deviation.

4.6.5 TEST SETUP

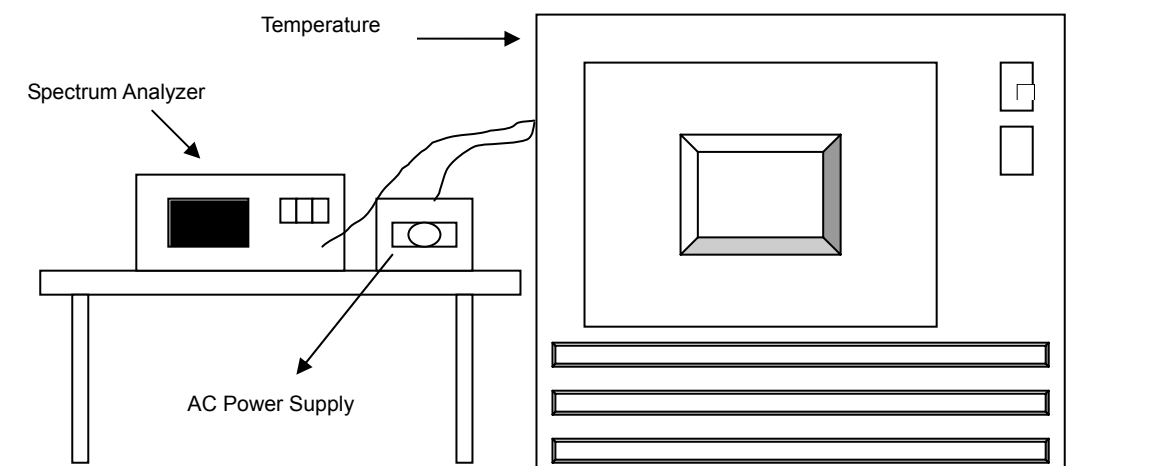

4.6.6 EUT OPERATING CONDITION

Same as item 4.1.6.

4.6.7 TEST RESULTS

FREQUENCY ERROR vs. TEMP.									
OPERATING FREQUENCY: 5240MHz									
TEMP. (°C)	POWER SUPPLY (Vac)	0 MINUTE		2 MINUTE		5 MINUTE		10 MINUTE	
		(MHz)	ppm	(MHz)	ppm	(MHz)	ppm	(MHz)	ppm
70	110.0	5239.988426	-2.209	5239.988714	-2.154	5239.988630	-2.170	5239.988466	-2.201
60	110.0	5239.988318	-2.229	5239.988553	-2.185	5239.988329	-2.227	5239.988518	-2.191
50	110.0	5239.989138	-2.073	5239.988606	-2.174	5239.988875	-2.123	5239.989049	-2.090
40	110.0	5239.990074	-1.894	5239.990657	-1.783	5239.990803	-1.755	5239.990008	-1.907
30	110.0	5239.991182	-1.683	5239.991465	-1.629	5239.991440	-1.634	5239.991922	-1.542
20	110.0	5239.993110	-1.315	5239.993434	-1.253	5239.993636	-1.215	5239.992972	-1.341
10	110.0	5239.990898	-1.737	5239.991361	-1.649	5239.991457	-1.630	5239.991232	-1.673
0	110.0	5239.989246	-2.052	5239.989039	-2.092	5239.989393	-2.024	5239.989597	-1.985
-10	110.0	5239.988865	-2.125	5239.989043	-2.091	5239.989591	-1.986	5239.989456	-2.012
-20	110.0	5239.988842	-2.129	5239.988939	-2.111	5239.988872	-2.124	5239.988738	-2.149
-30	110.0	5239.988258	-2.241	5239.988913	-2.116	5239.988911	-2.116	5239.988657	-2.165
-40	110.0	5239.988426	-2.209	5239.988714	-2.154	5239.988630	-2.170	5239.988466	-2.201

FREQUENCY ERROR vs. VOLTAGE									
OPERATING FREQUENCY: 5240MHz									
TEMP. (°C)	POWER SUPPLY (Vac)	0 MINUTE		2 MINUTE		5 MINUTE		10 MINUTE	
		(MHz)	ppm	(MHz)	ppm	(MHz)	ppm	(MHz)	ppm
20	93.5	5239.988984	-2.102	5239.989021	-2.095	5239.988796	-2.138	5239.988618	-2.172
20	110.0	5239.991182	-1.683	5239.991465	-1.629	5239.991440	-1.634	5239.991922	-1.542
20	126.5	5239.991749	-1.575	5239.991401	-1.641	5239.991568	-1.609	5239.991702	-1.584

4.7 BAND EDGES MEASUREMENT

4.7.1 TEST INSTRUMENTS

DESCRIPTION & MANUFACTURER	MODEL NO.	SERIAL NO.	DATE OF CALIBRATION	DUE DATE OF CALIBRATION
R&S SPECTRUM ANALYZER	FSP40	100039	Jan. 11, 2010	Jan. 10, 2011

NOTE: The calibration interval of the above test instruments is 12 months and the calibrations are traceable to NML/ROC and NIST/USA.

4.7.2 TEST PROCEDURE

The transmitter output was connected to the spectrum analyzer via a low loss cable. Set both RBW and VBW of spectrum analyzer to 1MHz and 3MHz with suitable frequency span including 100MHz bandwidth from band edge. The band edges was measured and recorded.

4.7.3 EUT OPERATING CONDITION

The software provided by client to enable the EUT under transmission condition continuously at specific channel frequencies individually.

4.7.4 TEST RESULTS

For signals in the restricted bands above and below the 5.15 to 5.25GHz allocated band a measurement was made of the amplitude of the spurious emissions with respect to the intentional signals. The relative amplitude, in dBc, was applied to the average and peak field strength of the intentional signal made on the OATS to calculate the field strength of the unintentional signals.

The spectrum plots (Peak RBW = 1MHz, VBW = 3MHz) are attached on the following pages.

802.11a

RESTRICT BAND (4500 ~ 5150 MHz)

FREQUENCY (MHz)	FUNDAMENTAL EMISSION (dBuV/m)	DELTA (dB)	MAXIMUM FIELD STRENGTH IN RESTRICT BAND (dBuV/m)	LIMIT (dBuV/m)
5180.00 (PK)	115.4	51.03	64.37	74.00
5180.00 (AV)	104.3	52.05	52.25	54.00

RESTRICT BAND (5350 ~ 5460 MHz)

FREQUENCY (MHz)	FUNDAMENTAL EMISSION (dBuV/m)	DELTA (dB)	MAXIMUM FIELD STRENGTH IN RESTRICT BAND (dBuV/m)	LIMIT (dBuV/m)
5240.00 (PK)	115.3	49.10	66.20	74.00
5240.00 (AV)	104.1	52.06	52.04	54.00

NOTE:

- Delta = Amplitude between the peak of the fundamental and the peak of the band edge emission. Please check following 3 pages.
- Maximum field strength in restrict band = Fundamental emission – Delta.



A D T

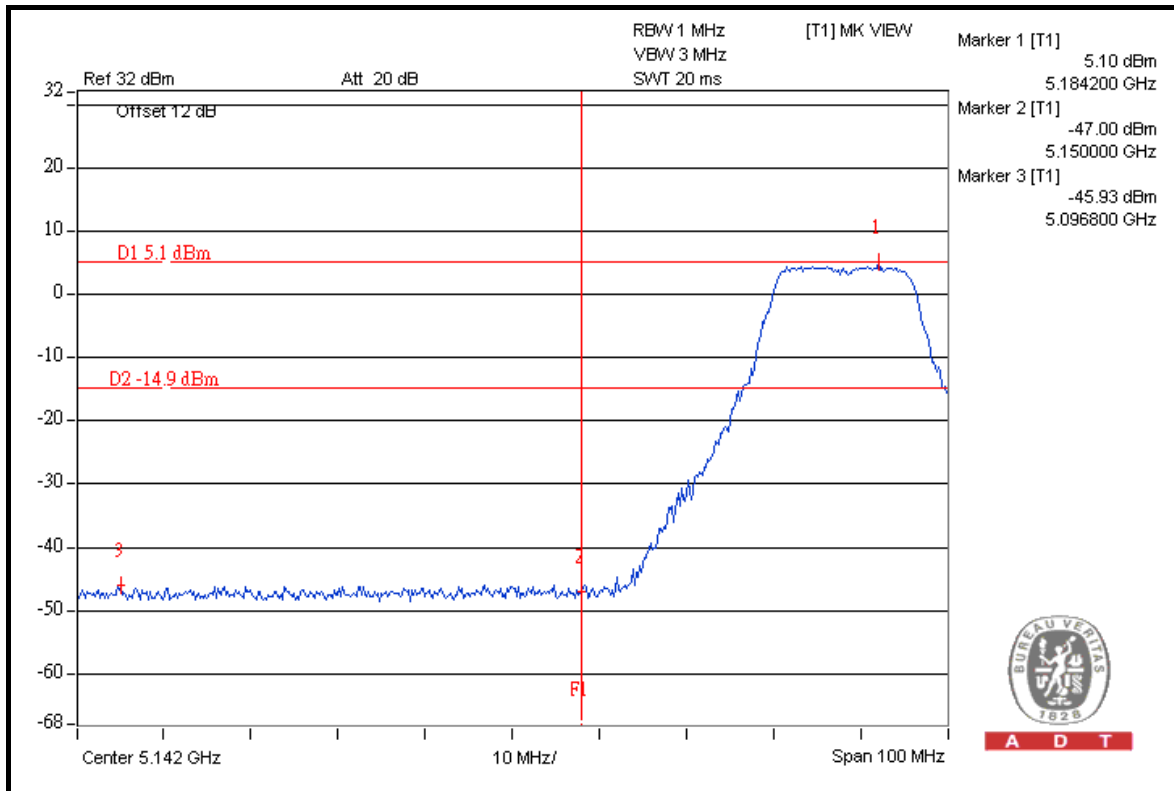

A D T

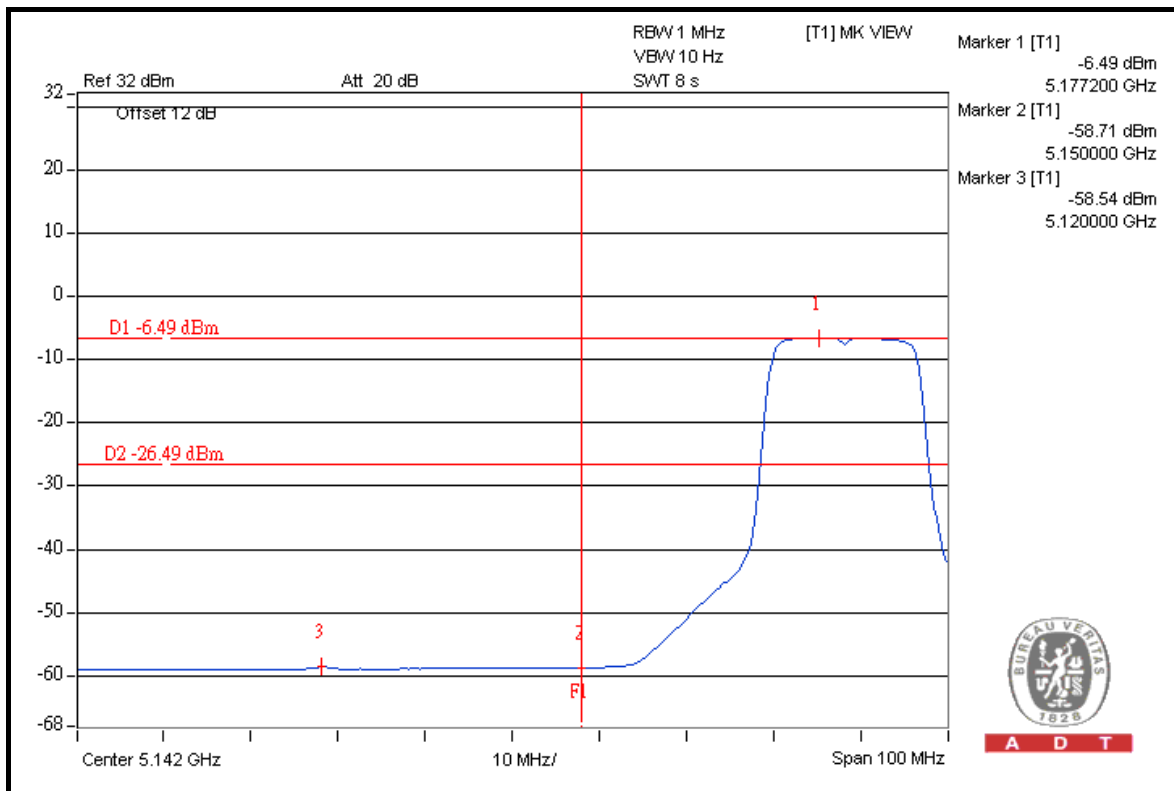

A D T



A D T

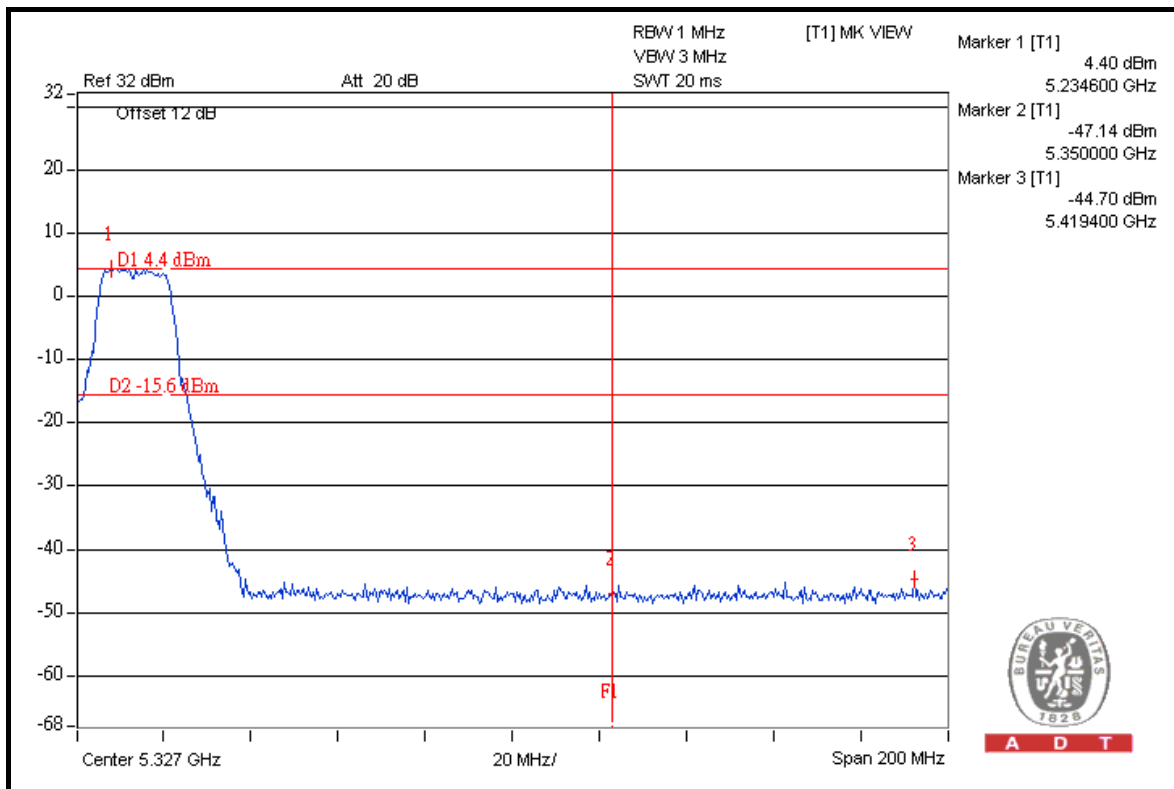
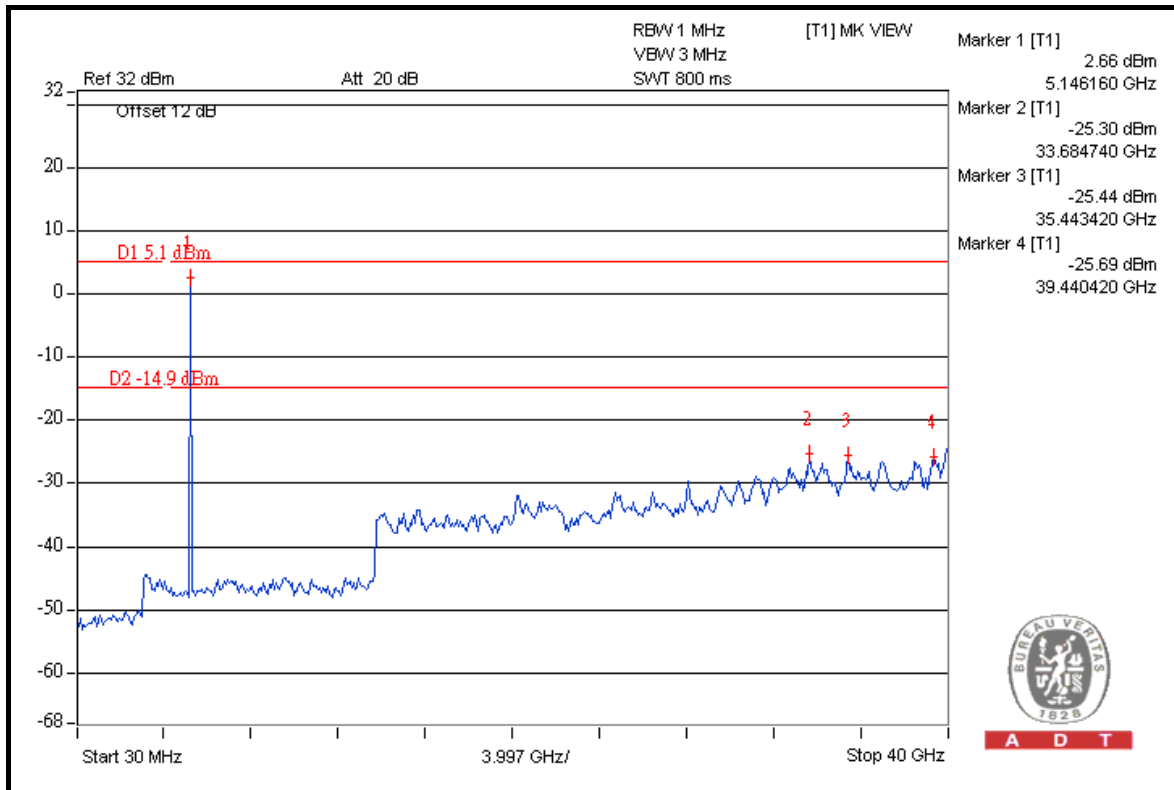



A D T

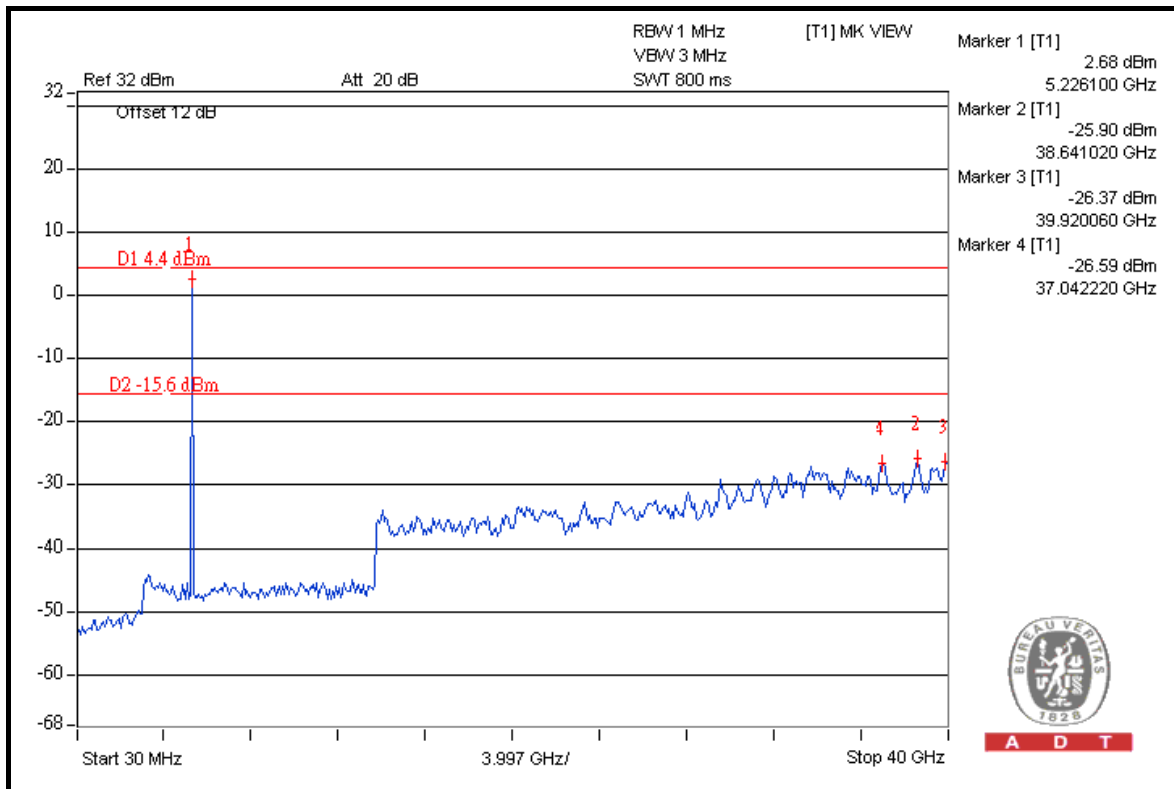
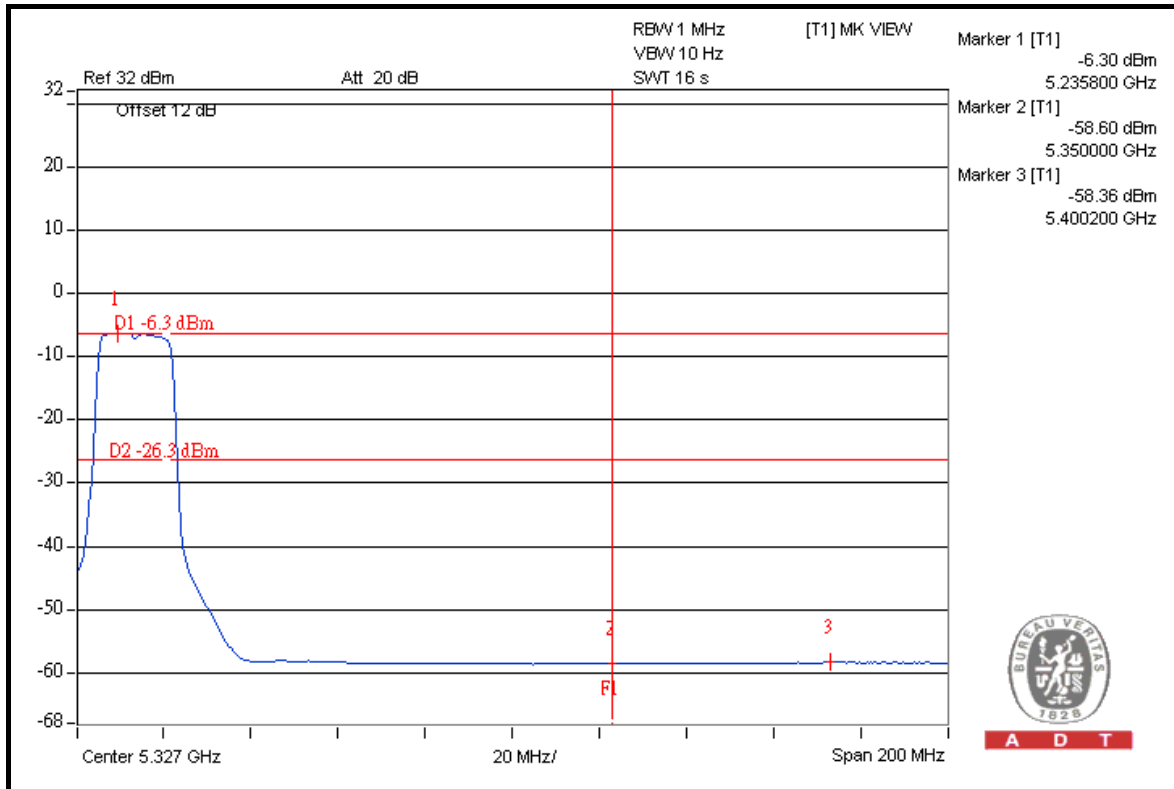



5. PHOTOGRAPHS OF THE TEST CONFIGURATION

Please refer to the attached file (Test Setup Photo).



6. INFORMATION ON THE TESTING LABORATORIES

We, Bureau Veritas Consumer Products Services (H.K.) Ltd., Taoyuan Branch, were founded in 1988 to provide our best service in EMC, Radio, Telecom and Safety consultation. Our laboratories are accredited and approved according to ISO/IEC 17025.

Copies of accreditation certificates of our laboratories obtained from approval agencies can be downloaded from our web site: www.adt.com.tw/index.5/phtml. If you have any comments, please feel free to contact us at the following:

Linko EMC/RF Lab:
Tel: 886-2-26052180
Fax: 886-2-26051924

Hsin Chu EMC/RF Lab:
Tel: 886-3-5935343
Fax: 886-3-5935342

Hwa Ya EMC/RF/Safety Telecom Lab:
Tel: 886-3-3183232
Fax: 886-3-3185050

Web Site: www.adt.com.tw

The address and road map of all our labs can be found in our web site also.

7. APPENDIX A - MODIFICATIONS RECORDERS FOR ENGINEERING CHANGES TO THE EUT BY THE LAB

No any modifications are made to the EUT by the lab during the test.

---END---