

REVISION HISTORY

Rev.2A

1. Change BU3 Power to +3V3.
2. Del BR13, BR14.
3. Change BC13 to 1nH_K,NI.
4. Change BC14 to 1pF_K,NI.
5. Change BC15 to 0_K.
6. Change RF Trace to 10.5mil width.
7. Power plane re-layout.
8. Increase board width for shielded cover.

QCOM QBTM300 Rev.2A

- Customized Form Factor Bluetooth Module
- CSR BC03-ROM Chipset
- Antenna Attached
- PN# 59-6175-2A

Component Suffix Table

_A: CASE A
_B: CASE B
_C: CASE C
_D: CASE D
_K: 0402
_E: 0603
_F: 0805
_G: 1206
_H: 1210
_I: 1812
_J: 2010
_K: 0402
_L: 1808
_NI: NOT INSTALL

QCOM		
Title		QBTM300
Size	Document Number	Rev
C	COVER PAGE	2A
Date: Monday, January 10, 2005		Sheet 1 of 2

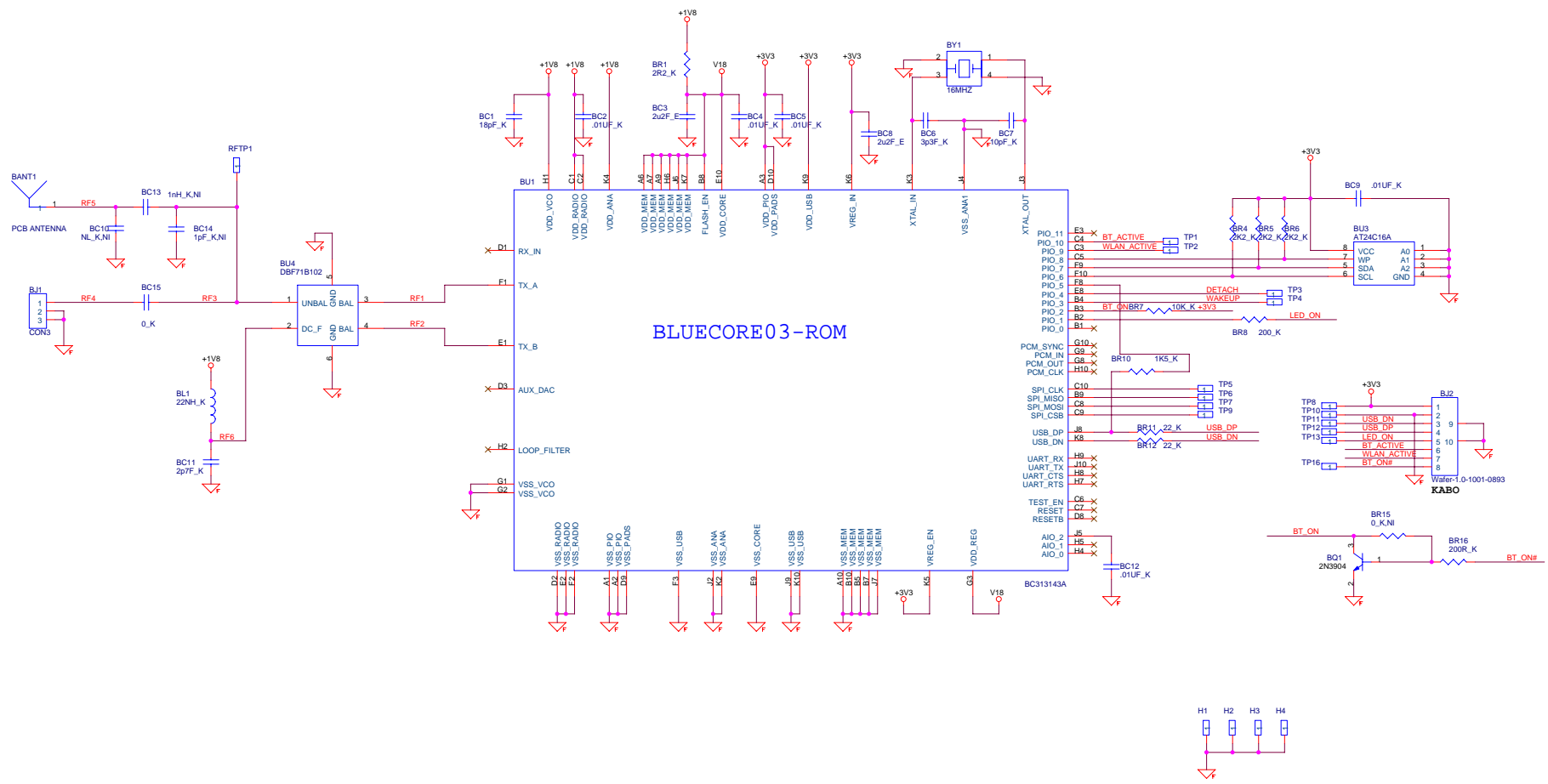

QCOM		
Title	QBTM300	
Size	Document Number	Rev
C	BC03-ROM	2A
Date:	Monday, January 10, 2005	Sheet 2 of 2