

Q802MKG-3A

#P/N: 59-6146-3A

Title		
COVER		
Size	Document Number	Rev
A	COVER	3A
Date:	Friday, March 05, 2004	Sheet 1 of 7

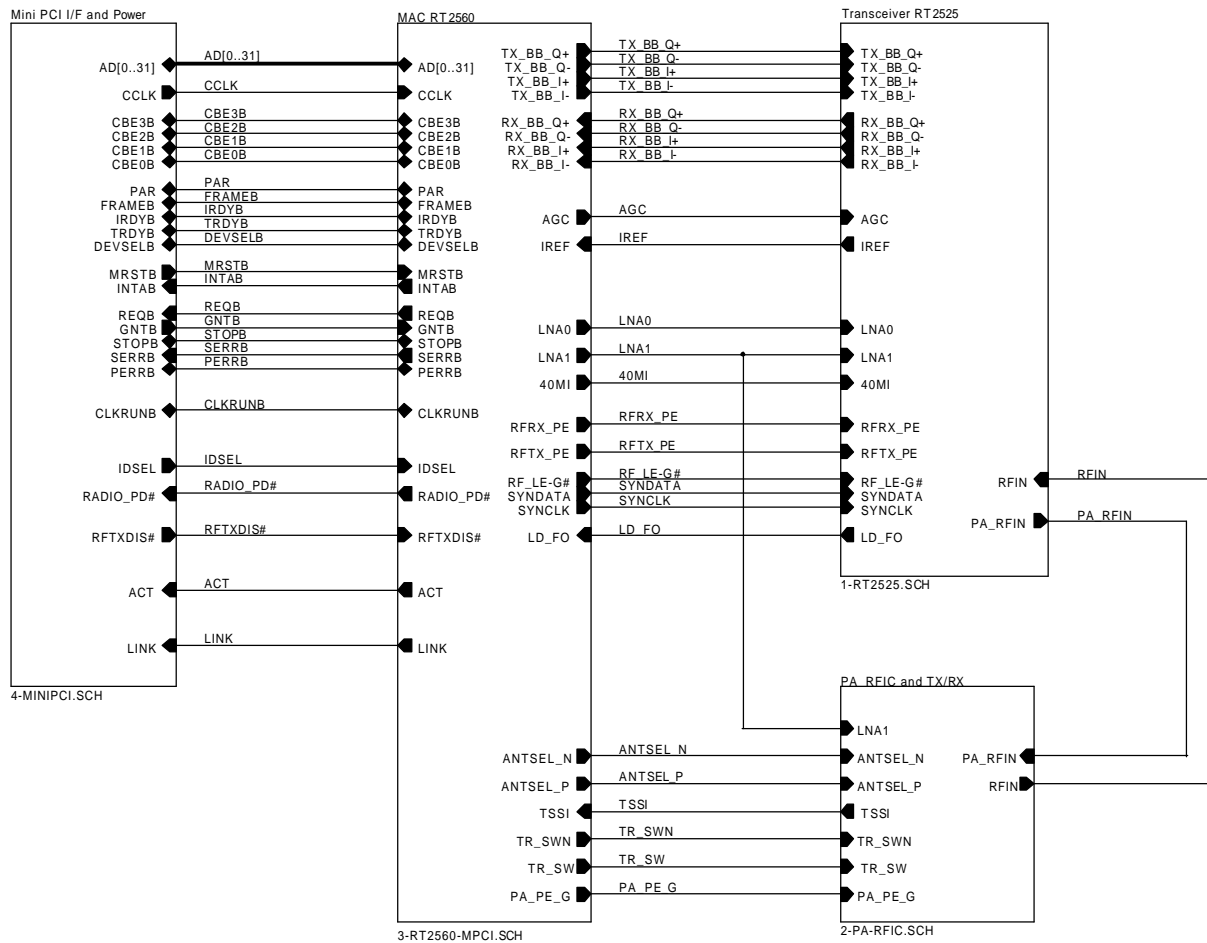

Title		
Mini PCI System - RT2560 + RT2525		
Size B	Document Number	Rev
	MPCI-RT2560-RT2525-RFIC-V32.SCH	3A
Date:	Friday, March 05, 2004	Sheet 2 of 7

U11 (SAW Filter)	C21, C21	C342, C343	L18
TFS374A (Telefilter)	1.8pF	8.2pF	47nH
TB0152A (TAI-SAW)	1.5pF	5.6pF	33nH

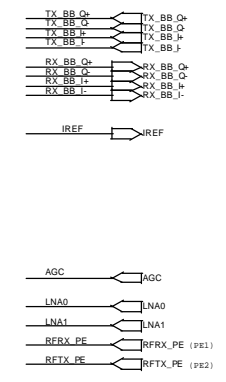
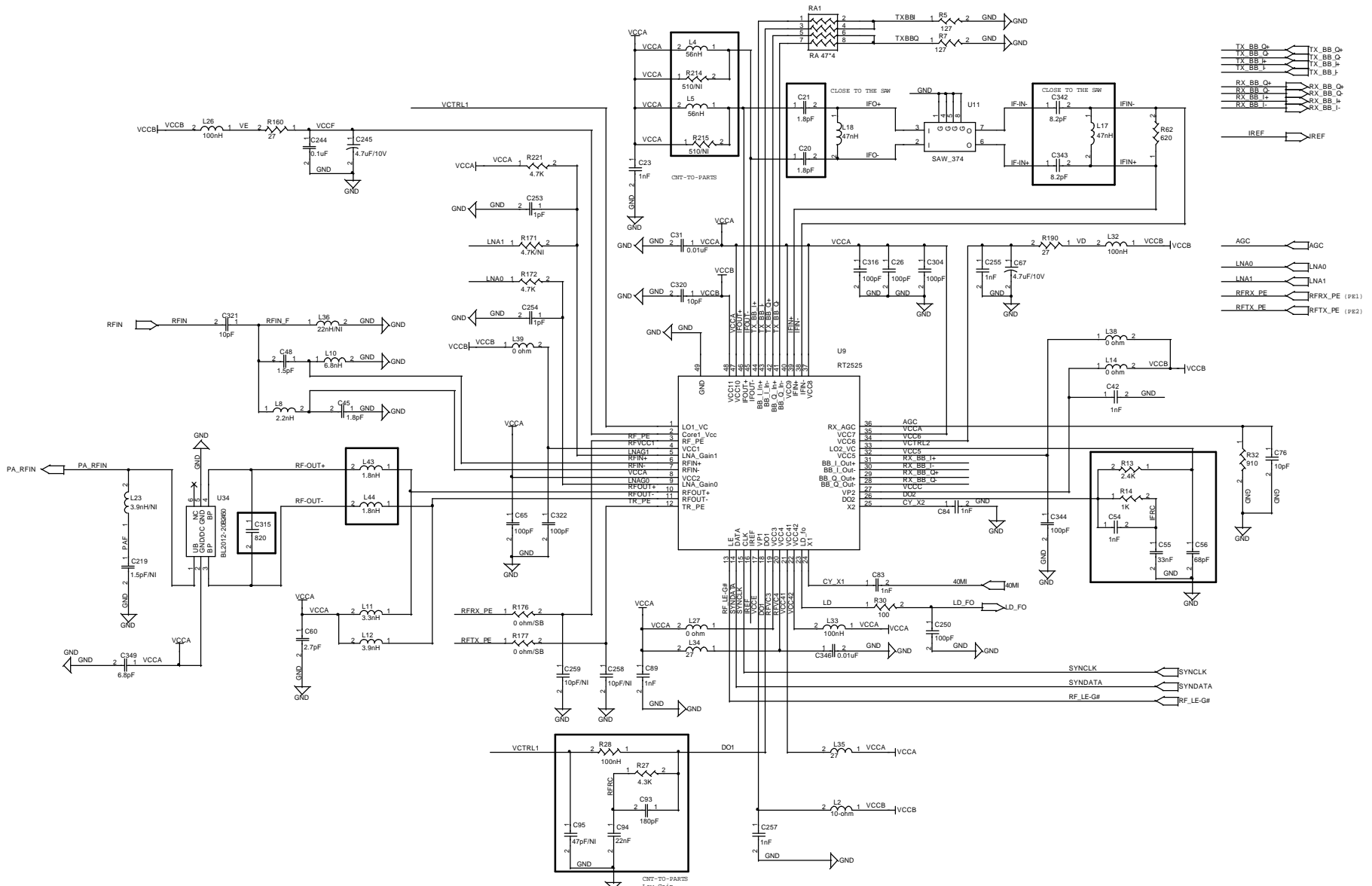

Title		
2.4GHz Transceiver - RT2525		
Size	Document Number	Rev
C	1-RT2525-SC14	3A
Date	Wednesday, March 03, 2004	Sheet 3 of 7

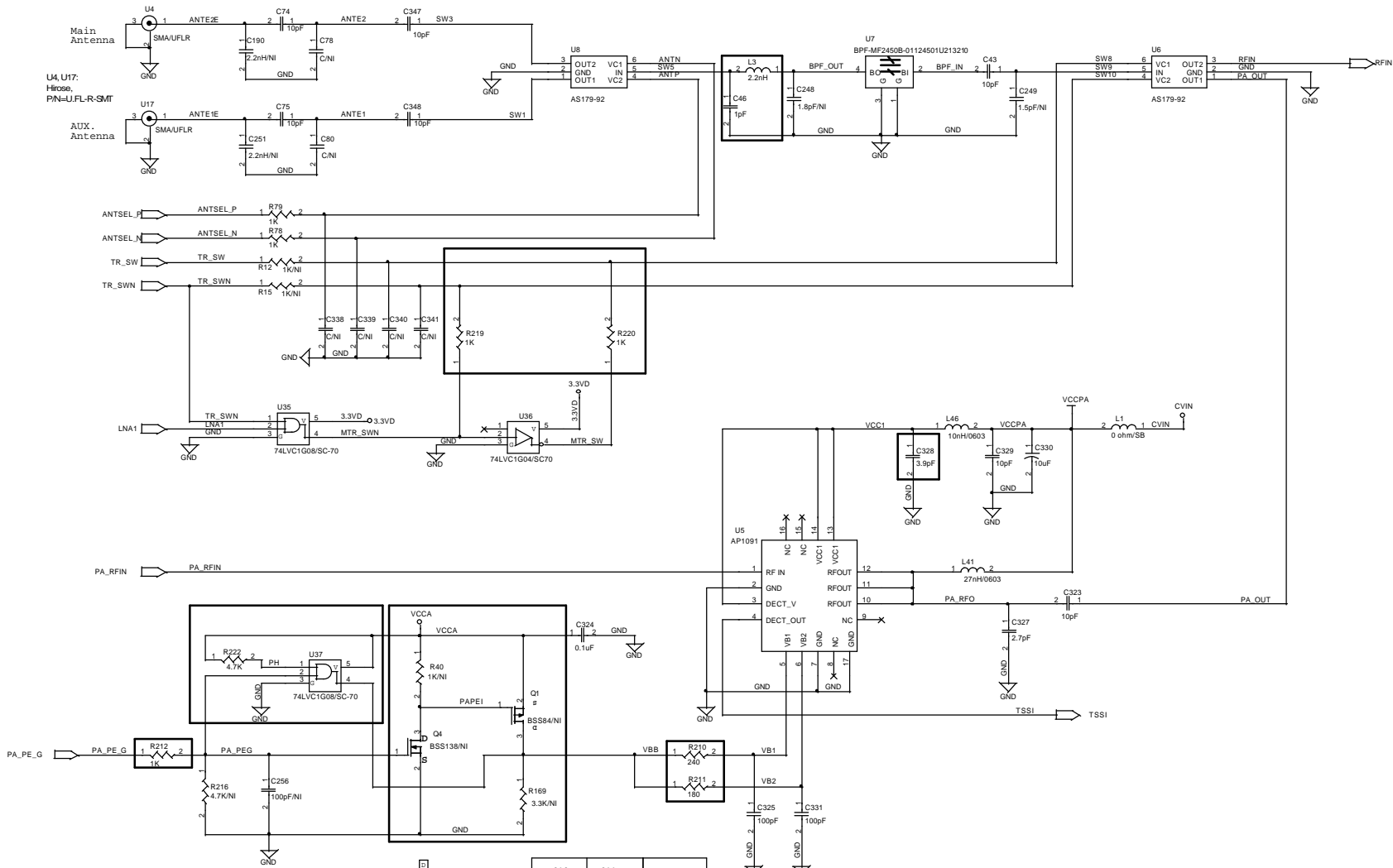

R210	R211	Note
150-ohm	100-ohm	Use 74LVC1G08
240-ohm	180-ohm	Use BSS84

Title		
PA and TXRX		
Size	Document Number	Rev
C	2-PA-RFIC.SCH	3A
Date	Friday, March 05, 2004	Sheet 4 of 7

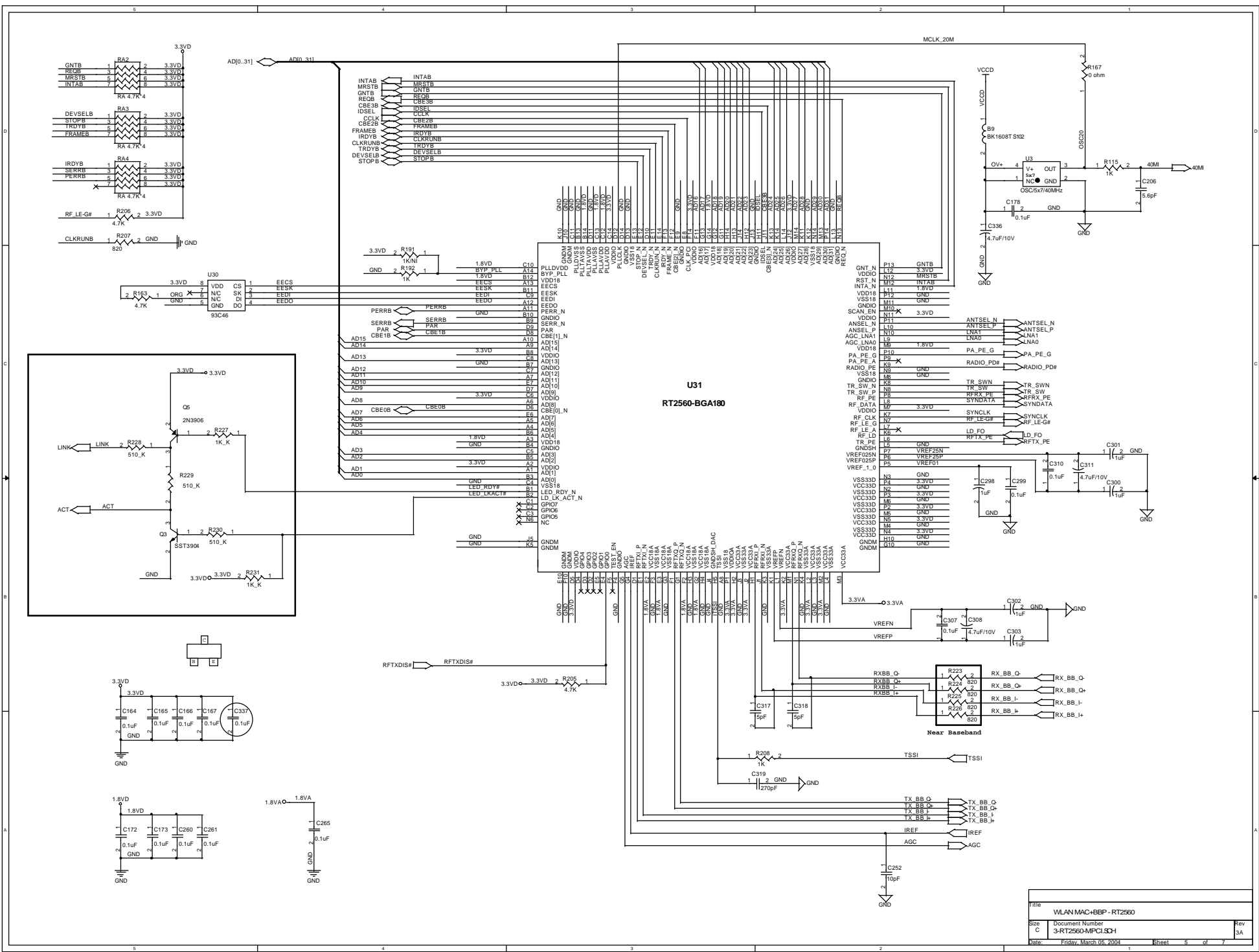

Title		
WLAN MAC+BBP - RT2560		
Size	Document Number	Rev
C	3-RT2560-MPC1.SCH	3A
Date	Friday, March 05, 2009	Sheet 5 of 7

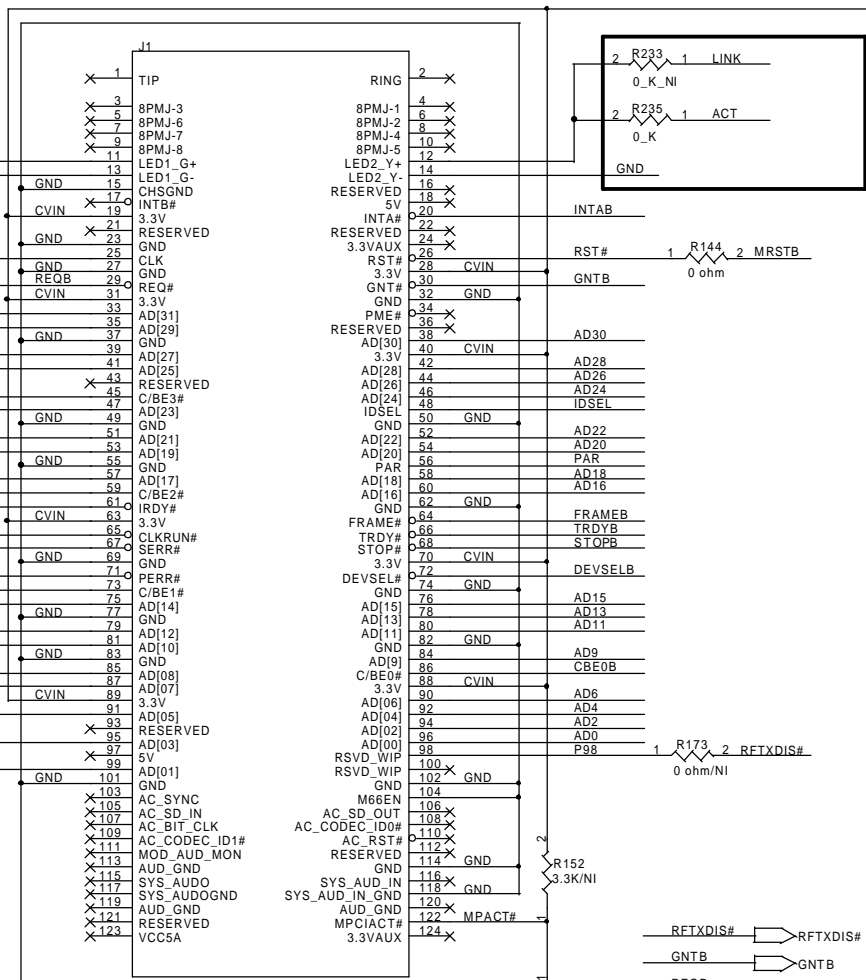
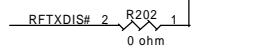
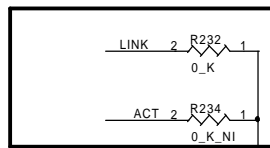

Type IIIB

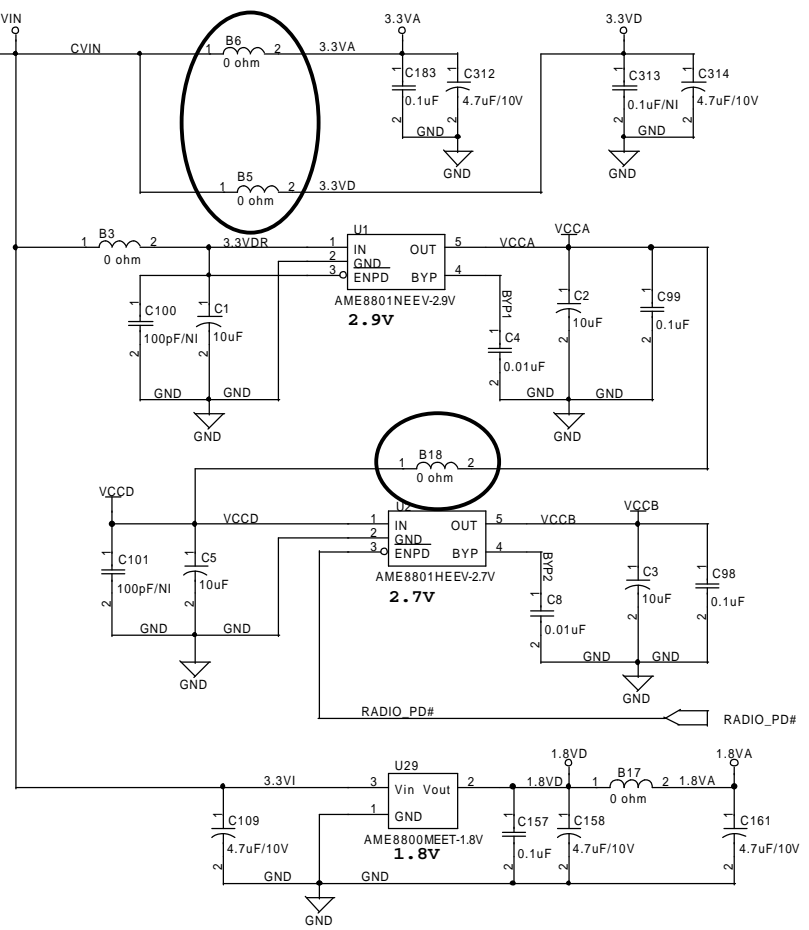
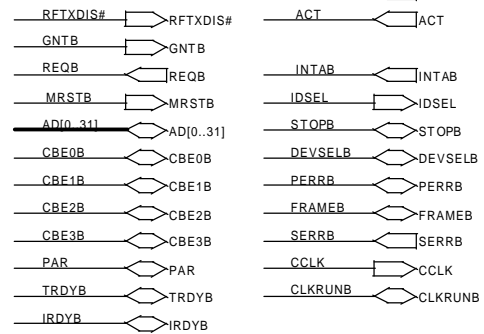

Title		
Mini PCI Interface and Power		
Size B	Document Number	Rev
	4-MINIPCI.SCH	3A
Date:	Monday, March 15, 2004	Sheet 6 of 7

Modify List

1. Change LED control circuit
2. Change part value(B6,B18,==>0 ohm)
3. Del B16, Add R232,R234, R233,R235

Title		
HISTORY		
Size	Document Number	Rev
A	HISTORY	3A
Date:	Monday, March 15, 2004	Sheet 7 of 7