



FCC TEST REPORT

REPORT NO.: RF930804L05

MODEL NO.: Q802MIAG

RECEIVED: Aug. 04, 2004

TESTED: Sep. 08 ~ Sep. 21, 2004

APPLICANT: Qcom Technology Inc.

ADDRESS: 7F, No.178, Ming Chuan E. Rd., Sec. 3, Taipei,
Taiwan, R.O.C.

ISSUED BY: Advance Data Technology Corporation

LAB ADDRESS: 47 14th Ling, Chia Pau Tsuen, Lin Kou Hsiang
244, Taipei Hsien, Taiwan, R.O.C.

TEST LOCATION: No. 19, Hwa Ya 2nd Rd., Wen Hwa Tsuen,
Kwei Shan Hsiang, Taoyuan Hsien 333,
Taiwan, R.O.C.

This test report consists of 130 pages in total. It may be duplicated completely for legal use with the approval of the applicant. It should not be reproduced except in full, without the written approval of our laboratory. The client should not use it to claim product endorsement by CNLA, A2LA or any government agencies. The test results in the report only apply to the tested sample.



0528
ILAC MRA



No. 2177-01



Table of Contents

1.	CERTIFICATION.....	5
2.	SUMMARY OF TEST RESULTS.....	6
2.1	MEASUREMENT UNCERTAINTY.....	8
3.	GENERAL INFORMATION	9
3.1	GENERAL DESCRIPTION OF EUT	9
3.2	DESCRIPTION OF TEST MODES	10
3.3	GENERAL DESCRIPTION OF APPLIED STANDARDS	10
3.4	DESCRIPTION OF SUPPORT UNITS.....	11
3.5	CONFIGURATION OF SYSTEM UNDER TEST.....	11
4.	TEST TYPES AND RESULTS (FOR PART 802.11b & 802.11g).....	12
4.1	CONDUCTED EMISSION MEASUREMENT	12
4.1.1	LIMITS OF CONDUCTED EMISSION MEASUREMENT	12
4.1.2	TEST INSTRUMENTS	12
4.1.3	TEST PROCEDURES.....	13
4.1.4	DEVIATION FROM TEST STANDARD	13
4.1.5	TEST SETUP	14
4.1.6	EUT OPERATING CONDITIONS.....	14
4.1.7	TEST RESULTS.....	15
4.2	RADIATED EMISSION MEASUREMENT	21
4.2.1	LIMITS OF RADIATED EMISSION MEASUREMENT	21
4.2.2	TEST INSTRUMENTS	22
4.2.3	TEST PROCEDURES.....	23
4.2.4	DEVIATION FROM TEST STANDARD	23
4.2.5	TEST SETUP	24
4.2.6	EUT OPERATING CONDITIONS.....	24
4.2.7	TEST RESULTS.....	25
4.3	6dB BANDWIDTH MEASUREMENT	33
4.3.1	LIMITS OF 6dB BANDWIDTH MEASUREMENT	33
4.3.2	TEST INSTRUMENTS	33
4.3.3	TEST PROCEDURE	33
4.3.4	DEVIATION FROM TEST STANDARD	34
4.3.5	TEST SETUP	34
4.3.6	EUT OPERATING CONDITIONS.....	34
4.3.7	TEST RESULTS.....	35
4.4	MAXIMUM PEAK OUTPUT POWER	43
4.4.1	LIMITS OF MAXIMUM PEAK OUTPUT POWER MEASUREMENT	43
4.4.2	INSTRUMENTS	43
4.4.3	TEST PROCEDURES.....	44
4.4.4	TEST SETUP	44
4.4.5	EUT OPERATING CONDITIONS.....	44
4.4.6	TEST RESULTS.....	45



4.5	POWER SPECTRAL DENSITY MEASUREMENT.....	46
4.5.1	LIMITS OF POWER SPECTRAL DENSITY MEASUREMENT	46
4.5.2	TEST INSTRUMENTS	46
4.5.3	TEST PROCEDURE	47
4.5.4	DEVIATION FROM TEST STANDARD	47
4.5.5	TEST SETUP	47
4.5.6	EUT OPERATING CONDITION	47
4.5.7	TEST RESULTS.....	48
4.6	BAND EDGES MEASUREMENT.....	56
4.6.1	LIMITS OF BAND EDGES MEASUREMENT	56
4.6.2	TEST INSTRUMENTS	56
4.6.3	TEST PROCEDURE	56
4.6.4	DEVIATION FROM TEST STANDARD	56
4.6.5	EUT OPERATING CONDITION	56
4.6.6	TEST RESULTS.....	57
4.7	ANTENNA REQUIREMENT.....	66
4.7.1	STANDARD APPLICABLE	66
4.7.2	ANTENNA CONNECTED CONSTRUCTION.....	66
5.	TEST TYPES AND RESULTS (FOR PART 802.11a)	67
5.1	CONDUCTED EMISSION MEASUREMENT	67
5.1.1	LIMITS OF CONDUCTED EMISSION MEASUREMENT	67
5.1.2	TEST INSTRUMENTS	67
5.1.3	TEST PROCEDURES.....	68
5.1.4	DEVIATION FROM TEST STANDARD	68
5.1.5	TEST SETUP	69
5.1.6	EUT OPERATING CONDITIONS.....	69
5.1.7	TEST RESULTS.....	70
5.2	RADIATED EMISSION MEASUREMENT	72
5.2.1	LIMITS OF RADIATED EMISSION MEASUREMENT	72
5.2.2	LIMITS OF UNWANTED EMISSION OUT OF THE RESTRICTED BANDS	73
5.2.3	TEST INSTRUMENTS	74
5.2.4	TEST PROCEDURES.....	75
5.2.5	DEVIATION FROM TEST STANDARD	75
5.2.6	TEST SETUP	76
5.2.7	EUT OPERATING CONDITIONS.....	76
5.2.8	TEST RESULTS.....	77
5.3	PEAK TRANSMIT POWER MEASUREMENT	85
5.3.1	LIMITS OF PEAK TRANSMIT POWER MEASUREMENT.....	85
5.3.2	TEST INSTRUMENTS	85
5.3.3	TEST PROCEDURE	86
5.3.4	DEVIATION FROM TEST STANDARD	86



5.3.5	TEST SETUP	86
5.3.6	EUT OPERATING CONDITIONS.....	86
5.3.7	TEST RESULTS.....	87
5.4	PEAK POWER EXCURSION MEASUREMENT	100
5.4.1	LIMITS OF PEAK POWER EXCURSION MEASUREMENT	100
5.4.2	TEST INSTRUMENTS	100
5.4.3	TEST PROCEDURE	101
5.4.4	DEVIATION FROM TEST STANDARD	101
5.4.5	TEST SETUP	101
5.4.6	EUT OPERATING CONDITIONS.....	101
5.4.7	TEST RESULTS.....	102
5.5	PEAK POWER SPECTRAL DENSITY MEASUREMENT	109
5.5.1	LIMITS OF PEAK POWER SPECTRAL DENSITY MEASUREMENT.....	109
5.5.2	TEST INSTRUMENTS	109
5.5.3	TEST PROCEDURES.....	110
5.5.4	DEVIATION FROM TEST STANDARD	110
5.5.5	TEST SETUP	110
5.5.6	EUT OPERATING CONDITIONS.....	110
5.5.7	TEST RESULTS.....	111
5.6	FREQUENCY STABILITY	118
5.6.1	LIMITS OF FREQUENCY STABILITY MEASUREMENT	118
5.6.2	TEST INSTRUMENTS	118
5.6.3	TEST PROCEDURE	118
5.6.4	DEVIATION FROM TEST STANDARD	119
5.6.5	TEST SETUP	119
5.6.6	EUT OPERATING CONDITION	119
5.6.7	TEST RESULTS.....	120
5.7	BAND EDGES MEASUREMENT	121
5.7.1	TEST INSTRUMENTS	121
5.7.2	TEST PROCEDURE	121
5.7.3	EUT OPERATING CONDITION	121
5.7.4	TEST RESULTS.....	121
5.8	ANTENNA REQUIREMENT.....	126
5.8.1	STANDARD APPLICABLE	126
5.8.2	ANTENNA CONNECTED CONSTRUCTION.....	126
6.	PHOTOGRAPHS OF THE TEST CONFIGURATION	127
7.	INFORMATION ON THE TESTING LABORATORIES.....	130



1. CERTIFICATION

PRODUCT: MiniPCI 802.11a/b/g Wireless LAN Card
BRAND NAME: Qcom
MODEL NO.: Q802MIAG
APPLICANT: Qcom Technology Inc.
TEST SAMPLE: Engineering Sample
TESTED: Sep. 08 ~ Sep. 21, 2004
STANDARDS: FCC Part 15, Subpart C (Section 15.247),
Subpart E (Section 15.407), ANSI C63.4-2001

The above equipment have been tested by **Advance Data Technology Corporation**, and found compliance with the requirement of the above standards. The test record, data evaluation & Equipment Under Test (EUT) configurations represented herein are true and accurate accounts of the measurements of the sample's EMC characteristics under the conditions specified in this report.

PREPARED BY : Windy Chou , **DATE:** Sep. 23, 2004
(Windy Chou)

TECHNICAL
ACCEPTANCE : Gary Chang , **DATE:** Sep. 23, 2004
Responsible for RF (Gary Chang)

APPROVED BY : Cody Chang , **DATE:** Sep. 23, 2004
(Cody Chang, Deputy Manager)



2. SUMMARY OF TEST RESULTS

The EUT has been tested according to the following specifications:

APPLIED STANDARD: FCC Part 15, Subpart C (Section 15.247)			
Standard Section	Test Type and Limit	Result	Remark
15.207	AC Power Conducted Emission	PASS	Meet the requirement of limit. Minimum passing margin is -19.25dB at 0.224MHz
15.247(a)(2)	Spectrum Bandwidth of a Direct Sequence Spread Spectrum System Limit: min. 500kHz	PASS	Meet the requirement of limit.
15.247(b)	Maximum Peak Output Power Limit: max. 30dBm	PASS	Meet the requirement of limit.
15.247(c)	Radiated Emissions Limit: Table 15.209	PASS	Meet the requirement of limit. Minimum passing margin is -1.84dB at 119.42MHz
15.247(d)	Power Spectral Density Limit: max. 8dBm	PASS	Meet the requirement of limit.
15.247(c)	Band Edge Measurement Limit: 20dB less than the peak value of fundamental frequency	PASS	Meet the requirement of limit.



APPLIED STANDARD: FCC Part 15, Subpart E (Section 15.407)

Standard Section	Test Type	Result	Remark
15.407(b)(5)	AC Power Conducted Emission	PASS	Meet the requirement of limit. Minimum passing margin is -19.19dB at 0.224MHz
15.407(b/1/2/3) (b)(5)	Electric Field Strength Spurious Emissions, 30MHz ~ 40000MHz	PASS	Meet the requirement of limit. Minimum passing margin is -1.01dB at 5715.00MHz
15.407(a/1/2/3)	Peak Transmit Power	PASS	Meet the requirement of limit.
15.407(a)(6)	Peak Power Excursion	PASS	Meet the requirement of limit.
15.407(a/1/2/3)	Peak Power Spectral Density	PASS	Meet the requirement of limit.
15.407(g)	Frequency Stability	PASS	Meet the requirement of limit.



2.1 MEASUREMENT UNCERTAINTY

Where relevant, the following measurement uncertainty levels have been estimated for tests performed on the EUT as specified in CISPR 16-4:

Measurement	Frequency	Uncertainty
Conducted emissions	9k~30MHz	2.44 dB
Radiated emissions	30MHz ~ 200MHz	3.73 dB
	200MHz ~1000MHz	3.74 dB
	1GHz ~ 18GHz	2.20 dB
	18GHz ~ 40GHz	1.88 dB



3. GENERAL INFORMATION

3.1 GENERAL DESCRIPTION OF EUT

EUT	MiniPCI 802.11a/b/g Wireless LAN Card
MODEL NO.	Q802MIAG
POWER SUPPLY	3.3Vdc from host equipment
MODULATION TYPE	DBPSK, DQPSK, CCK, 16QAM, 64QAM
MODULATION TECHNOLOGY	DSSS, OFDM
TRANSFER RATE	802.11b: 11/5.5/2/1Mbps 802.11g: 54/48/36/24/18/12/9/6Mbps 802.11a: 54/48/36/24/18/12/9/6Mbps
FREQUENCY RANGE	802.11b & 802.11g: 2412 ~ 2462MHz 802.11a: 5.15 ~ 5.35GHz and 5.725 ~ 5.850GHz
NUMBER OF CHANNEL	802.11b & 802.11g: 11 802.11a: 13
CHANNEL SPACING	802.11b & 802.11g: 5MHz 802.11a: 20MHz
OUTPUT POWER	802.11b: 52.481mW 802.11g: 16.596mW 802.11a: 32.359mW
DATA CABLE	NA
ANTENNA TYPE	PIFA antenna with 1.4dBi antenna gain (for 2.4GHz) PIFA antenna with 0dBi antenna gain (for 5.0GHz)
I/O PORTS	NA
ASSOCIATED DEVICES	NA

NOTE:

1. The EUT operates in both the 5GHz and 2.4GHz Bands and compatibility with 802.11a and 802.11b, 802.11g technology.
2. Fully compatible with the 802.11g standard to provide a wireless data rate of up to 54Mbps.
3. The above EUT information was declared by the manufacturer and for more detailed features description, please refer to the manufacturer's specifications or User's Manual.



3.2 DESCRIPTION OF TEST MODES

802.11b and 802.11g: Eleven channels are provided to this EUT.

Channel	Frequency	Channel	Frequency
1	2412 MHz	7	2442 MHz
2	2417 MHz	8	2447 MHz
3	2422 MHz	9	2452 MHz
4	2427 MHz	10	2457 MHz
5	2432 MHz	11	2462 MHz
6	2437 MHz		

NOTE:

1. Below 1GHz, the channel 1, 6, and 11 were pre-tested in chamber. The channel 11, worst case one, was chosen for final test. Above 1GHz, the channel 1, 6, and 11 were tested individually.
2. From our experience and technical viewpoint, we have chosen data rates, 11Mbps with CCK technique and 6Mbps with OFDM technique, as the worst cases for the test among other data rates.

For 802.11a: Twelve channels are provided to this EUT for Normal mode.

Channel	Frequency	Channel	Frequency
1	5180 MHz	7	5300 MHz
2	5200 MHz	8	5320 MHz
3	5220 MHz	9	5745MHz
4	5240 MHz	10	5765MHz
5	5260 MHz	11	5785MHz
6	5280 MHz	12	5805MHz

NOTE:

1. The EUT allows data rates of up to 54Mbps and was tested at 6Mbps data rate that produced the highest output power.
2. Channel 1, 4, 5, 8, 9 and 12 are the closest frequencies to the band edge, were chosen for final test.

3.3 GENERAL DESCRIPTION OF APPLIED STANDARDS

The EUT is a MiniPCI 802.11a/b/g Wireless LAN Card. According to the specifications of the manufacturer, it must comply with the requirements of the following standards:

**FCC Part 15, Subpart C. (15.247),
Subpart E (15.407). ANSI C63.4 : 2001**

All test items have been performed and recorded as per the above standards.

NOTE: The EUT is also considered as a kind of computer peripheral, because the connection to computer is necessary for typical use. It has been verified to comply with the requirements of FCC Part 15, Subpart B, Class B (DoC). The test report has been issued separately.



3.4 DESCRIPTION OF SUPPORT UNITS

The EUT has been tested as an independent unit together with other necessary accessories or support units. The following support units or accessories were used to form a representative test configuration during the tests.

NO.	PRODUCT	BRAND	MODEL NO.	SERIAL NO.	FCC ID
1	NOTEBOOK COMPUTER	DELL	PP05L	12130898320	E2K24CLNS
2	PRINTER	EPSON	LQ-300+	DCGY054147	FCC DoC Approved
3	MODEM	ACEEX	1414V/3	0401008269	IFAXDM1414

NO.	SIGNAL CABLE DESCRIPTION OF THE ABOVE SUPPORT UNITS
1	NA
2	1.2m braid shielded wire, terminated with DB25 and Centronics connector via metallic frame, w/o core
3	1.2m shielded without core

NOTE: All power cords of the above support units are non shielded (1.8m).

3.5 CONFIGURATION OF SYSTEM UNDER TEST

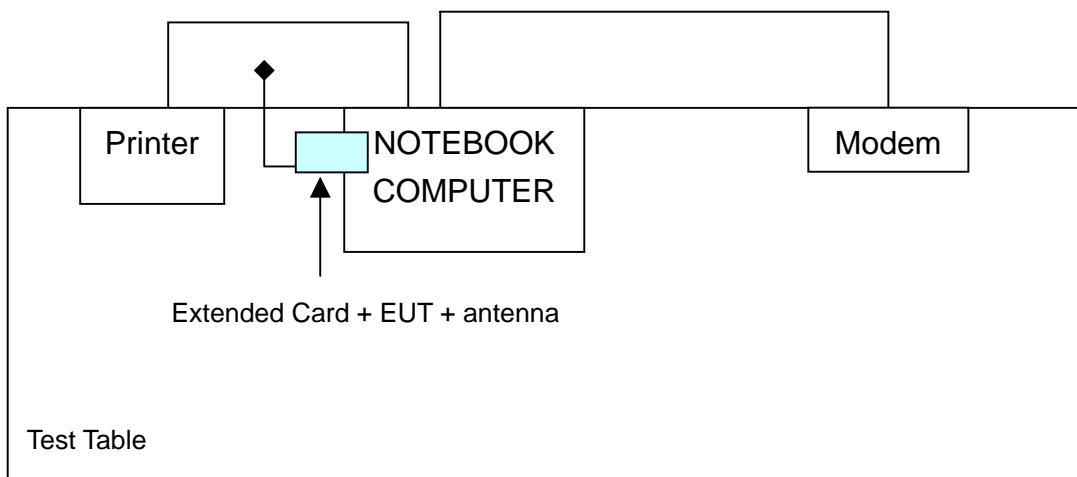



4. TEST TYPES AND RESULTS (FOR PART 802.11b & 802.11g)

4.1 CONDUCTED EMISSION MEASUREMENT

4.1.1 LIMITS OF CONDUCTED EMISSION MEASUREMENT

FREQUENCY OF EMISSION (MHz)	CONDUCTED LIMIT (dBµV)	
	Quasi-peak	Average
0.15-0.5	66 to 56	56 to 46
0.5-5	56	46
5-30	60	50

- NOTE:**
1. The lower limit shall apply at the transition frequencies.
 2. The limit decreases in line with the logarithm of the frequency in the range of 0.15 to 0.50 MHz.
 3. All emanations from a class A/B digital device or system, including any network of conductors and apparatus connected thereto, shall not exceed the level of field strengths specified above.

4.1.2 TEST INSTRUMENTS

DESCRIPTION & MANUFACTURER	MODEL NO.	SERIAL NO.	CALIBRATED UNTIL
Test Receiver ROHDE & SCHWARZ	ESCS30	100288	Dec. 11, 2004
RF signal cable Woken	5D-FB	Cable-HyC02-01	Mar. 07, 2005
LISN ROHDE & SCHWARZ	ESH2-Z5	100100	Mar. 10, 2005
LISN ROHDE & SCHWARZ	ESH3-Z5	100311	Mar. 04, 2005
Software ADT	ADT_Cond_V3	NA	NA

- NOTE:**
1. The calibration interval of the above test instruments is 12 months and the calibrations are traceable to NML/ROC and NIST/USA.
 2. The test was performed in HwaYa Shielded Room 2.
 3. The VCCI Site Registration No. is C-2047.



4.1.3 TEST PROCEDURES

- a. The EUT was placed 0.4 meters from the conducting wall of the shielded room with EUT being connected to the power mains through a line impedance stabilization network (LISN). Other support units were connected to the power mains through another LISN. The two LISNs provide 50 ohm/ 50uH of coupling impedance for the measuring instrument.
- b. Both lines of the power mains connected to the EUT were checked for maximum conducted interference.
- c. The frequency range from 150kHz to 30MHz was searched. Emission levels under (Limit - 20dB) was not recorded.

4.1.4 DEVIATION FROM TEST STANDARD

No deviation

4.1.5 TEST SETUP

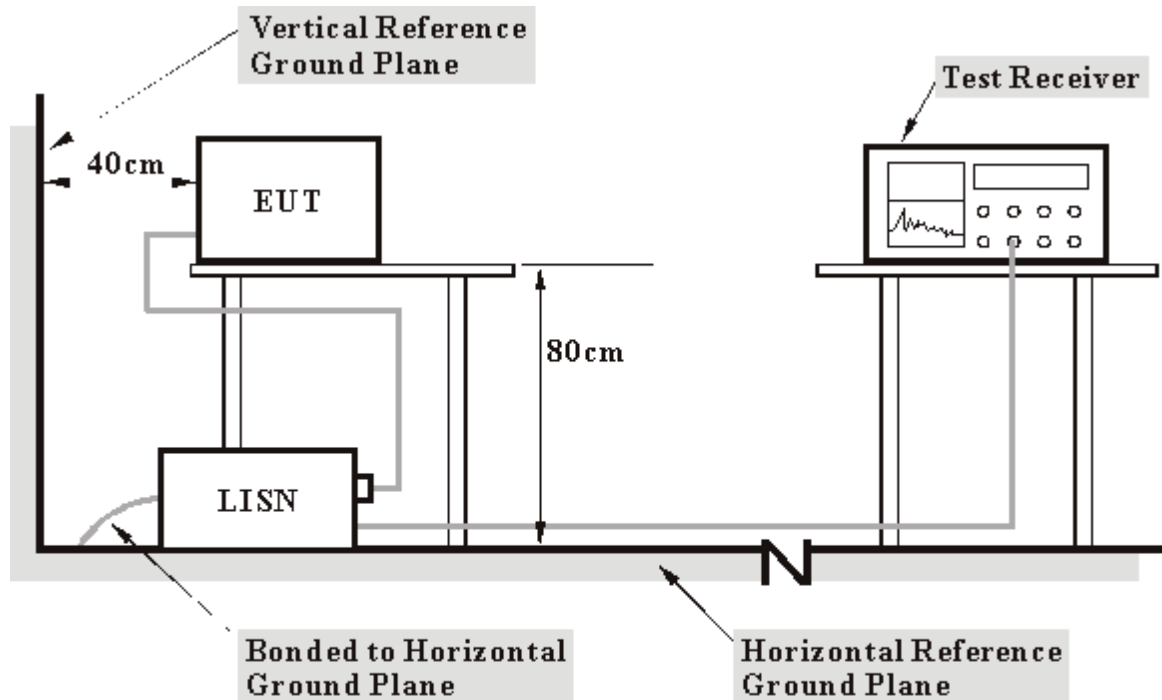

- Note:**
1. Support units were connected to second LISN.
 2. Both of LISNs (AMN) 80 cm from EUT and at the least 80 cm from other units and other metal planes support units.

For the actual test configuration, please refer to the related item – Photographs of the Test Configuration.

4.1.6 EUT OPERATING CONDITIONS

- a. Connected the EUT via the extended card to a notebook system placed on a testing table.
- b. The notebook system ran a test program (provided by manufacturer) to enable EUT under transmission/receiving condition continuously at specific channel frequency.
- c. The notebook system sent "H" messages to its screen.
- d. The notebook system sent "H" messages to modem.
- e. The notebook system sent "H" messages to printer, and the printer prints them on paper.



f. Steps c-e are repeated.

4.1.7 TEST RESULTS

EUT	MiniPCI 802.11a/b/g Wireless LAN Card	MODEL	Q802MIAG
MODE	Channel 1	6dB BANDWIDTH	9 kHz
INPUT POWER (SYSTEM)	120Vac, 60Hz	PHASE	Line (L)
ENVIRONMENTAL CONDITIONS	25deg. C, 65%RH, 991hPa	TESTED BY: Match Tsui	

No	Freq. [MHz]	Corr. Factor [dB]	Reading Value [dB (uV)]		Emission Level [dB (uV)]		Limit [dB (uV)]		Margin (dB)	
			Q.P.	AV.	Q.P.	AV.	Q.P.	AV.	Q.P.	AV.
			1	0.170	0.10	42.58	-	42.68	-	64.98
2	0.259	0.10	31.55	-	31.65	-	61.45	51.45	-29.80	-
3	1.289	0.25	27.85	-	28.10	-	56.00	46.00	-27.90	-
4	1.957	0.26	30.72	-	30.98	-	56.00	46.00	-25.02	-
5	10.695	0.55	34.97	-	35.52	-	60.00	50.00	-24.48	-
6	16.438	0.76	28.86	-	29.62	-	60.00	50.00	-30.38	-

- REMARKS:**
1. Q.P. and AV. are abbreviations of quasi-peak and average individually.
 2. "-": The Quasi-peak reading value also meets average limit and measurement with the average detector is unnecessary.
 3. The emission levels of other frequencies were very low against the limit.
 4. Margin value = Emission level - Limit value
 5. Correction factor = Insertion loss + Cable loss
 6. Emission Level = Correction Factor + Reading Value.

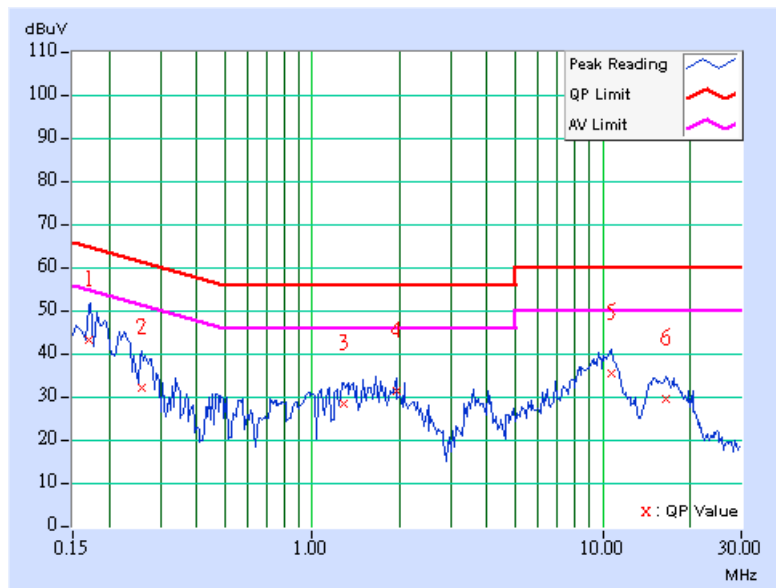



EUT	MiniPCI 802.11a/b/g Wireless LAN Card	MODEL	Q802MIAG
MODE	Channel 1	6dB BANDWIDTH	9 kHz
INPUT POWER (SYSTEM)	120Vac, 60Hz	PHASE	Neutral (N)
ENVIRONMENTAL CONDITIONS	25deg. C, 65%RH, 991hPa	TESTED BY: Match Tsui	

No	Freq. [MHz]	Corr. Factor (dB)	Reading Value [dB (uV)]		Emission Level [dB (uV)]		Limit [dB (uV)]		Margin (dB)	
			Q.P.	AV.	Q.P.	AV.	Q.P.	AV.	Q.P.	AV.
	1	0.154	0.10	36.84	-	36.94	-	65.79	55.79	-28.85
2	0.224	0.10	42.37	-	42.47	-	62.66	52.66	-20.19	-
3	1.234	0.24	29.34	-	29.58	-	56.00	46.00	-26.42	-
4	1.645	0.25	31.26	-	31.51	-	56.00	46.00	-24.49	-
5	9.781	0.48	35.31	-	35.79	-	60.00	50.00	-24.21	-
6	17.590	0.61	27.82	-	28.43	-	60.00	50.00	-31.57	-

- REMARKS:**
1. Q.P. and AV. are abbreviations of quasi-peak and average individually.
 2. "-": The Quasi-peak reading value also meets average limit and measurement with the average detector is unnecessary.
 3. The emission levels of other frequencies were very low against the limit.
 4. Margin value = Emission level - Limit value
 5. Correction factor = Insertion loss + Cable loss
 6. Emission Level = Correction Factor + Reading Value.

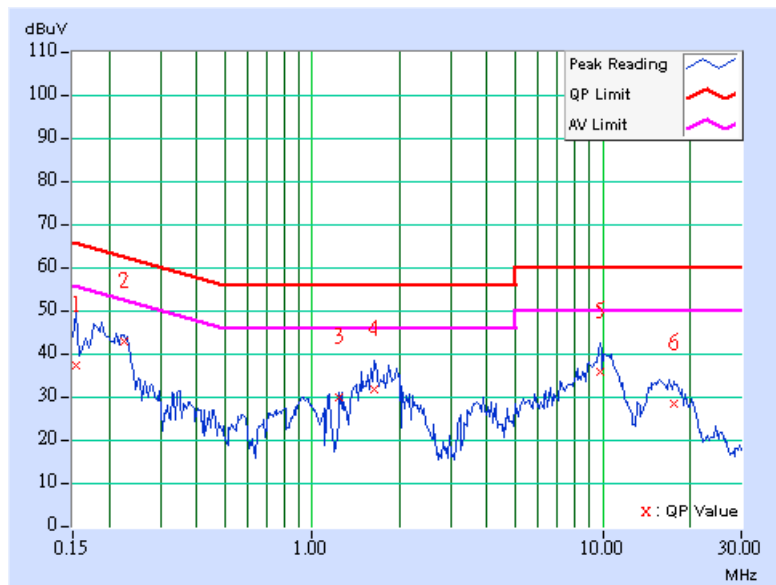



EUT	MiniPCI 802.11a/b/g Wireless LAN Card	MODEL	Q802MIAG
MODE	Channel 6	6dB BANDWIDTH	9 kHz
INPUT POWER (SYSTEM)	120Vac, 60Hz	PHASE	Line (L)
ENVIRONMENTAL CONDITIONS	25deg. C, 65%RH, 991hPa	TESTED BY: Match Tsui	

No	Freq. [MHz]	Corr. Factor (dB)	Reading Value [dB (uV)]		Emission Level [dB (uV)]		Limit [dB (uV)]		Margin (dB)	
			Q.P.	AV.	Q.P.	AV.	Q.P.	AV.	Q.P.	AV.
	1	0.193	0.10	40.75	-	40.85	-	63.91	53.91	-23.06
2	0.220	0.10	43.03	-	43.13	-	62.81	52.81	-19.68	-
3	0.998	0.25	27.26	-	27.51	-	56.00	46.00	-28.49	-
4	1.898	0.26	30.39	-	30.65	-	56.00	46.00	-25.35	-
5	10.289	0.54	35.76	-	36.30	-	60.00	50.00	-23.70	-
6	16.453	0.76	28.82	-	29.58	-	60.00	50.00	-30.42	-

- REMARKS:**
1. Q.P. and AV. are abbreviations of quasi-peak and average individually.
 2. "-": The Quasi-peak reading value also meets average limit and measurement with the average detector is unnecessary.
 3. The emission levels of other frequencies were very low against the limit.
 4. Margin value = Emission level - Limit value
 5. Correction factor = Insertion loss + Cable loss
 6. Emission Level = Correction Factor + Reading Value.

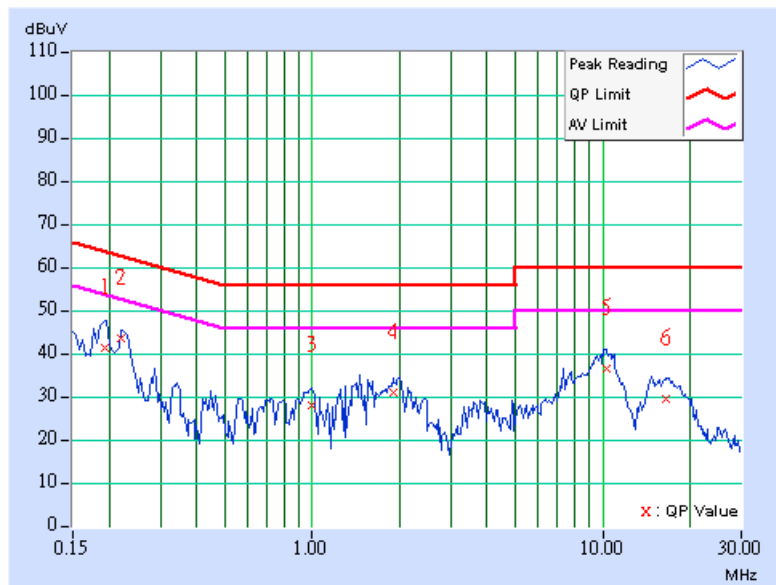



EUT	MiniPCI 802.11a/b/g Wireless LAN Card	MODEL	Q802MIAG
MODE	Channel 6	6dB BANDWIDTH	9 kHz
INPUT POWER (SYSTEM)	120Vac, 60Hz	PHASE	Neutral (N)
ENVIRONMENTAL CONDITIONS	25deg. C, 65%RH, 991hPa	TESTED BY: Match Tsui	

No	Freq. [MHz]	Corr. Factor (dB)	Reading Value [dB (uV)]		Emission Level [dB (uV)]		Limit [dB (uV)]		Margin (dB)	
			Q.P.	AV.	Q.P.	AV.	Q.P.	AV.	Q.P.	AV.
	1	0.185	0.10	40.04	-	40.14	-	64.25	54.25	-24.11
2	0.220	0.10	42.49	-	42.59	-	62.81	52.81	-20.22	-
3	1.336	0.24	30.41	-	30.65	-	56.00	46.00	-25.35	-
4	1.719	0.25	32.30	-	32.55	-	56.00	46.00	-23.45	-
5	10.273	0.49	35.74	-	36.23	-	60.00	50.00	-23.77	-
6	16.762	0.59	28.85	-	29.44	-	60.00	50.00	-30.56	-

- REMARKS:**
1. Q.P. and AV. are abbreviations of quasi-peak and average individually.
 2. "-": The Quasi-peak reading value also meets average limit and measurement with the average detector is unnecessary.
 3. The emission levels of other frequencies were very low against the limit.
 4. Margin value = Emission level - Limit value
 5. Correction factor = Insertion loss + Cable loss
 6. Emission Level = Correction Factor + Reading Value.

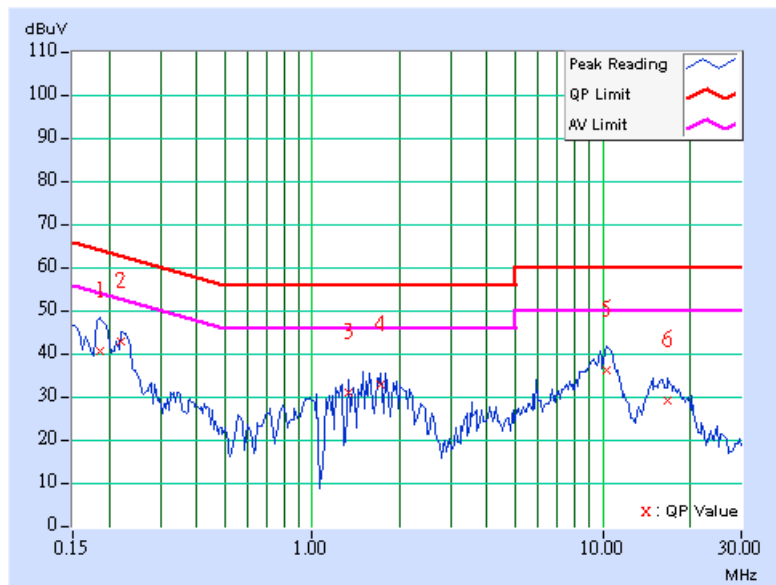



EUT	MiniPCI 802.11a/b/g Wireless LAN Card	MODEL	Q802MIAG
MODE	Channel 11	6dB BANDWIDTH	9 kHz
INPUT POWER (SYSTEM)	120Vac, 60Hz	PHASE	Line (L)
ENVIRONMENTAL CONDITIONS	25deg. C, 65%RH, 991hPa	TESTED BY: Match Tsui	

No	Freq. [MHz]	Corr. Factor (dB)	Reading Value [dB (uV)]		Emission Level [dB (uV)]		Limit [dB (uV)]		Margin (dB)	
			Q.P.	AV.	Q.P.	AV.	Q.P.	AV.	Q.P.	AV.
	1	0.170	0.10	38.41	-	38.51	-	64.98	54.98	-26.47
2	0.224	0.10	43.31	-	43.41	-	62.66	52.66	-19.25	-
3	1.344	0.25	30.35	-	30.60	-	56.00	46.00	-25.40	-
4	2.027	0.26	29.10	-	29.36	-	56.00	46.00	-26.64	-
5	10.137	0.53	35.65	-	36.18	-	60.00	50.00	-23.82	-
6	16.988	0.79	28.73	-	29.52	-	60.00	50.00	-30.48	-

- REMARKS:**
1. Q.P. and AV. are abbreviations of quasi-peak and average individually.
 2. "-": The Quasi-peak reading value also meets average limit and measurement with the average detector is unnecessary.
 3. The emission levels of other frequencies were very low against the limit.
 4. Margin value = Emission level - Limit value
 5. Correction factor = Insertion loss + Cable loss
 6. Emission Level = Correction Factor + Reading Value.

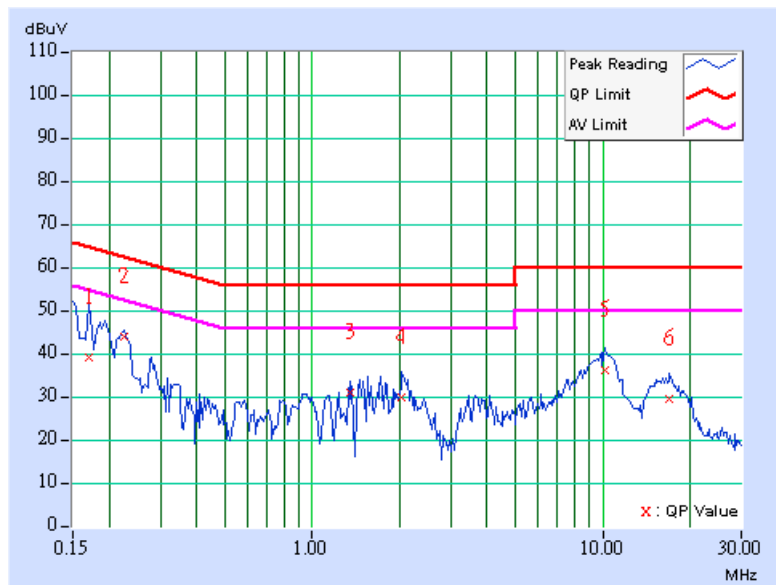



EUT	MiniPCI 802.11a/b/g Wireless LAN Card	MODEL	Q802MIAG
MODE	Channel 11	6dB BANDWIDTH	9 kHz
INPUT POWER (SYSTEM)	120Vac, 60Hz	PHASE	Neutral (N)
ENVIRONMENTAL CONDITIONS	25deg. C, 65%RH, 991hPa	TESTED BY: Match Tsui	

No	Freq. [MHz]	Corr. Factor (dB)	Reading Value [dB (uV)]		Emission Level [dB (uV)]		Limit [dB (uV)]		Margin (dB)	
			Q.P.	AV.	Q.P.	AV.	Q.P.	AV.	Q.P.	AV.
	1	0.185	0.10	40.08	-	40.18	-	64.25	54.25	-24.07
2	0.220	0.10	42.89	-	42.99	-	62.81	52.81	-19.82	-
3	1.473	0.24	31.42	-	31.66	-	56.00	46.00	-24.34	-
4	1.980	0.25	29.80	-	30.05	-	56.00	46.00	-25.95	-
5	10.676	0.50	35.05	-	35.55	-	60.00	50.00	-24.45	-
6	16.434	0.59	28.98	-	29.57	-	60.00	50.00	-30.43	-

- REMARKS:**
1. Q.P. and AV. are abbreviations of quasi-peak and average individually.
 2. "-": The Quasi-peak reading value also meets average limit and measurement with the average detector is unnecessary.
 3. The emission levels of other frequencies were very low against the limit.
 4. Margin value = Emission level - Limit value
 5. Correction factor = Insertion loss + Cable loss
 6. Emission Level = Correction Factor + Reading Value.

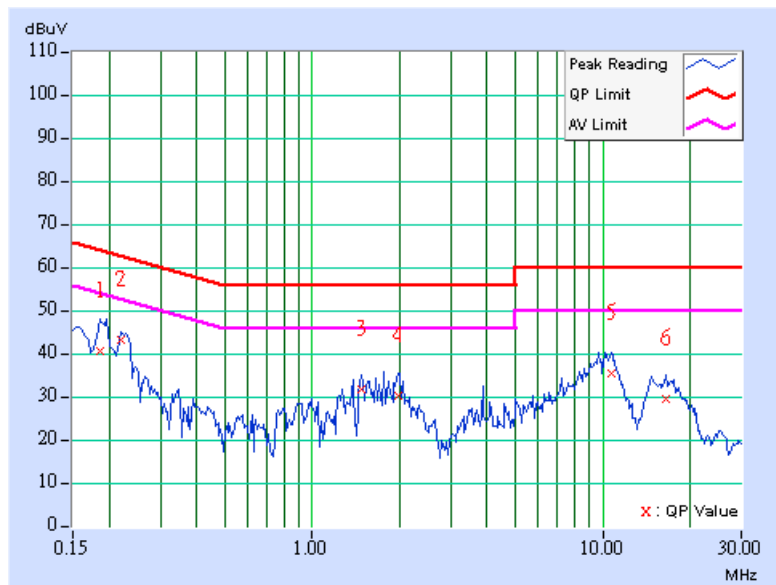



4.2 RADIATED EMISSION MEASUREMENT

4.2.1 LIMITS OF RADIATED EMISSION MEASUREMENT

Emissions radiated outside of the specified bands, shall be according to the general radiated limits in 15.209 as following:

Frequencies (MHz)	Field strength (microvolts/meter)	Measurement distance (meters)
0.009-0.490	2400/F(kHz)	300
0.490-1.705	24000/F(kHz)	30
1.705-30.0	30	30
30-88	100	3
88-216	150	3
216-960	200	3
Above 960	500	3

NOTE:

1. The lower limit shall apply at the transition frequencies.
2. Emission level (dBuV/m) = 20 log Emission level (uV/m).
3. As shown in 15.35(b), for frequencies above 1000MHz, the field strength limits are based on average detector, however, the peak field strength of any emission shall not exceed the maximum permitted average limits, specified above by more than 20dB under any condition of modulation.



4.2.2 TEST INSTRUMENTS

DESCRIPTION & MANUFACTURER	MODEL NO.	SERIAL NO.	CALIBRATED UNTIL
Test Receiver ROHDE & SCHWARZ	ESIB7	100188	Jan. 13, 2005
Spectrum Analyzer ROHDE & SCHWARZ	FSP40	100039	Dec. 15, 2004
BILOG Antenna SCHWARZBECK	VULB9168	9168-157	Feb. 03, 2005
HORN Antenna SCHWARZBECK	BBHA 9120 D	9120D-407	Feb. 03, 2005
HORN Antenna SCHWARZBECK	BBHA 9170	BBHA 9170241	Feb. 23, 2005
Preamplifier Agilent	8449B	3008A01961	Jan. 22, 2005
Preamplifier Agilent	8447D	2944A10629	Jan. 14, 2005
RF signal cable HUBER+SUHNER	SUCOFLEX 104	218182/4	Mar. 04, 2005
RF signal cable HUBER+SUHNER	SUCOFLEX 104	218194/4	Mar. 04, 2005
Software ADT.	ADT_Radiated_V5.14	NA	NA
Antenna Tower ADT.	AT100	AT93021702	NA
Turn Table ADT.	TT100.	TT93021702	NA
Controller ADT.	SC100.	SC93021702	NA

- NOTE:** 1. The calibration interval of the above test instruments is 12 months and the calibrations are traceable to NML/ROC and NIST/USA.
2. The test was performed in HwaYa Chamber 1.
3. The horn antenna and HP preamplifier (model: 8449B) are used only for the measurement of emission frequency above 1GHz if tested.
4. The IC Site Registration No. is IC4924-2.



4.2.3 TEST PROCEDURES

- a. The EUT was placed on the top of a rotating table 0.8 meters above the ground at a 3 meter semi- anechoic. The table was rotated 360 degrees to determine the position of the highest radiation.
- b. The EUT was set 3 meters away from the interference-receiving antenna, which was mounted on the top of a variable-height antenna tower.
- c. The antenna is a broadband antenna, and its height is varied from one meter to four meters above the ground to determine the maximum value of the field strength. Both horizontal and vertical polarizations of the antenna are set to make the measurement.
- d. For each suspected emission, the EUT was arranged to its worst case and then the antenna was tuned to heights from 1 meter to 4 meters and the rotatable table was turned from 0 degrees to 360 degrees to find the maximum reading.
- e. The test-receiver system was set to Peak Detect Function and Specified Bandwidth with Maximum Hold Mode.
- f. If the emission level of the EUT in peak mode was 10 dB lower than the limit specified, then testing could be stopped and the peak values of the EUT would be reported. Otherwise the emissions that did not have 10 dB margin would be re-tested one by one using the quasi-peak method or average method as specified and then reported in Data sheet peak mode and QP mode.

NOTE:

1. The resolution bandwidth and video bandwidth of test receiver/spectrum analyzer is 120kHz for Quasi-peak detection at frequency below 1GHz.
2. The resolution bandwidth and video bandwidth of test receiver/spectrum analyzer is 1 MHz for Peak detection (PK) at frequency above 1GHz.
3. The resolution bandwidth of test receiver/spectrum analyzer is 1 MHz and the video bandwidth is 10 Hz for Average detection (AV) at frequency above 1GHz.

4.2.4 DEVIATION FROM TEST STANDARD

No deviation

4.2.5 TEST SETUP

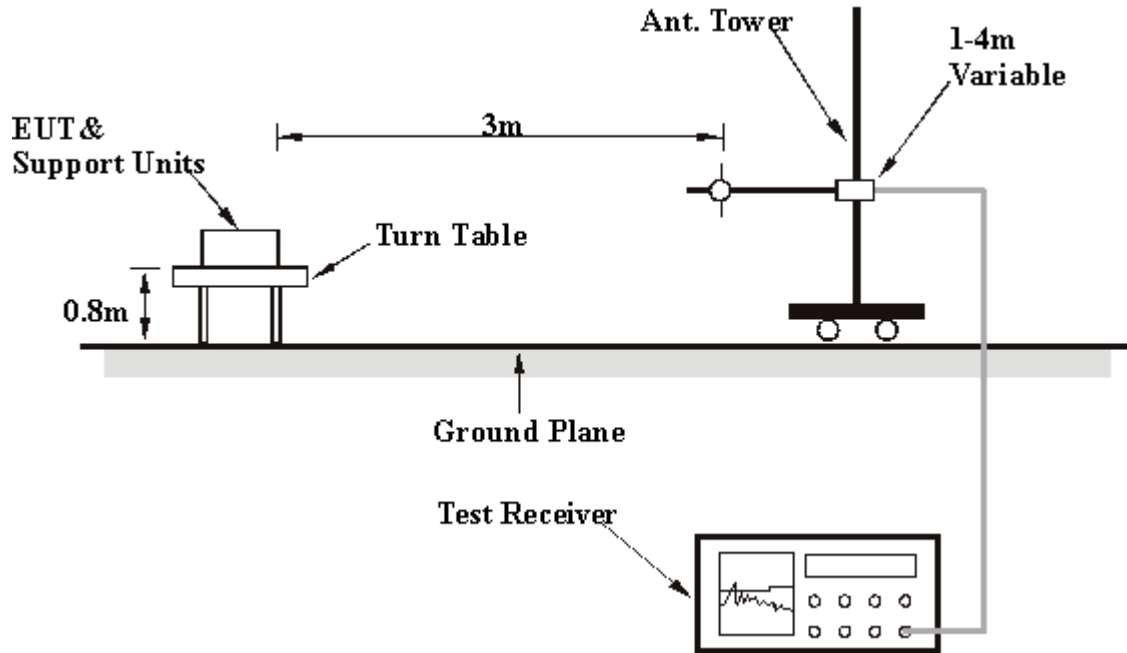

For the actual test configuration, please refer to the related item – Photographs of the Test Configuration.

4.2.6 EUT OPERATING CONDITIONS

Same as 4.1.6



4.2.7 TEST RESULTS

EUT	MiniPCI 802.11a/b/g Wireless LAN Card	MODEL	Q802MIAG
CHANNEL	Channel 11	FREQUENCY RANGE	Below 1000MHz
INPUT POWER (SYSTEM)	120Vac, 60 Hz	DETECTOR FUNCTION	Quasi-Peak
ENVIRONMENTAL CONDITIONS	25deg. C, 60%RH, 991hPa	TESTED BY: Match Tsui	

ANTENNA POLARITY & TEST DISTANCE: HORIZONTAL AT 3 M								
No.	Freq. (MHz)	Emission Level (dBuV/m)	Limit (dBuV/m)	Margin (dB)	Antenna Height (m)	Table Angle (Degree)	Raw Value (dBuV)	Correction Factor (dB/m)
1	99.98	38.12 QP	43.50	-5.38	2.50 H	340	27.14	10.98
2	119.42	41.66 QP	43.50	-1.84	1.50 H	325	28.68	12.97
3	133.03	38.28 QP	43.50	-5.22	3.00 H	166	24.34	13.94
4	160.24	35.22 QP	43.50	-8.28	2.50 H	328	20.35	14.87
5	239.94	25.72 QP	46.00	-20.28	1.50 H	91	12.64	13.07
6	331.30	39.69 QP	46.00	-6.31	1.00 H	319	24.47	15.22
7	360.46	43.44 QP	46.00	-2.56	1.00 H	181	27.56	15.88
8	440.16	40.25 QP	46.00	-5.75	2.00 H	1	22.44	17.81
9	479.04	35.71 QP	46.00	-10.29	1.50 H	22	17.26	18.45
10	519.86	38.73 QP	46.00	-7.27	1.50 H	4	19.62	19.11
11	560.68	36.04 QP	46.00	-9.96	1.50 H	16	16.06	19.97
12	599.56	37.98 QP	46.00	-8.02	1.00 H	10	16.98	21.00
13	640.38	35.90 QP	46.00	-10.10	1.00 H	22	14.35	21.55
14	731.74	36.42 QP	46.00	-9.58	1.00 H	310	13.34	23.08
15	799.78	35.55 QP	46.00	-10.45	1.00 H	307	11.73	23.82
16	943.63	42.89 QP	46.00	-3.11	1.50 H	13	17.32	25.57

- REMARKS:**
1. Emission level(dBuV/m)=Raw Value(dBuV) + Correction Factor(dB)
 2. Correction Factor(dB/m) = Antenna Factor (dB/m) + Cable Factor (dB)
 3. The other emission levels were very low against the limit.
 4. Margin value = Emission level – Limit value



EUT	MiniPCI 802.11a/b/g Wireless LAN Card	MODEL	Q802MIAG
CHANNEL	Channel 11	FREQUENCY RANGE	Below 1000MHz
INPUT POWER (SYSTEM)	120Vac, 60 Hz	DETECTOR FUNCTION	Quasi-Peak
ENVIRONMENTAL CONDITIONS	25deg. C, 60%RH, 991hPa	TESTED BY: Match Tsui	

ANTENNA POLARITY & TEST DISTANCE: VERTICAL AT 3 M

No.	Freq. (MHz)	Emission Level (dBuV/m)	Limit (dBuV/m)	Margin (dB)	Antenna Height (m)	Table Angle (Degree)	Raw Value (dBuV)	Correction Factor (dB/m)
1	59.16	31.21 QP	40.00	-8.79	1.50 V	316	17.41	13.79
2	98.04	35.20 QP	43.50	-8.30	1.50 V	277	24.38	10.83
3	119.42	33.00 QP	43.50	-10.50	2.50 V	148	20.03	12.97
4	333.25	32.17 QP	46.00	-13.83	1.50 V	22	16.90	15.26
5	360.46	36.93 QP	46.00	-9.07	2.50 V	142	21.05	15.88
6	383.79	32.90 QP	46.00	-13.10	1.50 V	340	16.51	16.39
7	440.16	31.79 QP	46.00	-14.21	2.00 V	82	13.98	17.81
8	465.43	31.77 QP	46.00	-14.23	1.00 V	328	13.50	18.27
9	479.04	32.63 QP	46.00	-13.37	1.00 V	349	14.17	18.45
10	519.86	31.92 QP	46.00	-14.08	1.00 V	340	12.81	19.11
11	560.68	32.38 QP	46.00	-13.62	1.50 V	271	12.40	19.97
12	599.56	33.32 QP	46.00	-12.68	1.50 V	271	12.33	21.00
13	640.38	29.75 QP	46.00	-16.25	1.00 V	10	8.20	21.55
14	799.78	28.66 QP	46.00	-17.34	1.00 V	328	4.84	23.82
15	906.69	29.64 QP	46.00	-16.36	2.00 V	10	4.46	25.18

- REMARKS:**
1. Emission level(dBuV/m)=Raw Value(dBuV) + Correction Factor(dB)
 2. Correction Factor(dB/m) = Antenna Factor (dB/m) + Cable Factor (dB)
 3. The other emission levels were very low against the limit.
 4. Margin value = Emission level – Limit value



EUT	MiniPCI 802.11a/b/g Wireless LAN Card	MODEL	Q802MIAG
CHANNEL	Channel 1	FREQUENCY RANGE	1 ~ 25GHz
MODE	CCK		
INPUT POWER (SYSTEM)	120Vac, 60 Hz	DETECTOR FUNCTION	Peak(PK) Average (AV)
ENVIRONMENTAL CONDITIONS	25deg. C, 65%RH, 991hPa	TESTED BY: Rush Kao	

ANTENNA POLARITY & TEST DISTANCE: HORIZONTAL AT 3 M								
No.	Freq. (MHz)	Emission Level (dBuV/m)	Limit (dBuV/m)	Margin (dB)	Antenna Height (m)	Table Angle (Degree)	Raw Value (dBuV)	Correction Factor (dB/m)
1	2390.00	55.00 PK	74.00	-19.00	1.00 H	215	21.17	33.83
1	2390.00	47.41 AV	54.00	-6.59	1.00 H	215	13.58	33.83
2	*2412.00	107.56 PK			1.00 H	215	73.63	33.93
2	*2412.00	99.42 AV			1.00 H	215	65.49	33.93
3	7236.00	57.10 PK	74.00	-16.90	1.06 H	274	9.26	47.84
3	7236.00	43.17 AV	54.00	-10.83	1.06 H	274	-4.67	47.84

ANTENNA POLARITY & TEST DISTANCE: VERTICAL AT 3 M								
No.	Freq. (MHz)	Emission Level (dBuV/m)	Limit (dBuV/m)	Margin (dB)	Antenna Height (m)	Table Angle (Degree)	Raw Value (dBuV)	Correction Factor (dB/m)
1	2390.00	52.12 PK	74.00	-21.88	1.12 V	213	18.29	33.83
1	2390.00	43.94 AV	54.00	-10.06	1.12 V	213	10.11	33.83
2	*2412.00	104.16 PK			1.12 V	213	70.23	33.93
2	*2412.00	95.95 AV			1.12 V	213	62.02	33.93
3	7236.00	57.57 PK	74.00	-16.43	1.16 V	214	9.73	47.84
3	7236.00	43.82 AV	54.00	-10.18	1.16 V	214	-4.02	47.84

- REMARKS:**
1. Emission level(dBuV/m)=Raw Value(dBuV) + Correction Factor(dB)
 2. Correction Factor(dB/m) = Antenna Factor (dB/m) + Cable Factor (dB)
 3. The other emission levels were very low against the limit.
 4. Margin value = Emission level – Limit value.
 5. “ * “ : Fundamental frequency



EUT	MiniPCI 802.11a/b/g Wireless LAN Card	MODEL	Q802MIAG
CHANNEL	Channel 6	FREQUENCY RANGE	1 ~ 25GHz
MODE	CCK		
INPUT POWER (SYSTEM)	120Vac, 60 Hz	DETECTOR FUNCTION	Peak(PK) Average (AV)
ENVIRONMENTAL CONDITIONS	25deg. C, 65%RH, 991hPa	TESTED BY: Rush Kao	

ANTENNA POLARITY & TEST DISTANCE: HORIZONTAL AT 3M								
No.	Freq. (MHz)	Emission Level (dBuV/m)	Limit (dBuV/m)	Margin (dB)	Antenna Height (m)	Table Angle (Degree)	Raw Value (dBuV)	Correction Factor (dB/m)
1	*2437.00	107.15 PK			1.00 H	216	73.10	34.05
1	*2437.00	98.98 AV			1.00 H	216	64.93	34.05

ANTENNA POLARITY & TEST DISTANCE: VERTICAL AT 3M								
No.	Freq. (MHz)	Emission Level (dBuV/m)	Limit (dBuV/m)	Margin (dB)	Antenna Height (m)	Table Angle (Degree)	Raw Value (dBuV)	Correction Factor (dB/m)
1	*2437.00	104.40 PK			1.31 V	215	70.35	34.05
1	*2437.00	96.25 AV			1.31 V	215	62.20	34.05

- REMARKS:**
1. Emission level(dBuV/m)=Raw Value(dBuV) + Correction Factor(dB)
 2. Correction Factor(dB/m) = Antenna Factor (dB/m) + Cable Factor (dB)
 3. The other emission levels were very low against the limit.
 4. Margin value = Emission level – Limit value.
 5. “ * “ : Fundamental frequency



EUT	MiniPCI 802.11a/b/g Wireless LAN Card	MODEL	Q802MIAG
CHANNEL	Channel 11	FREQUENCY RANGE	1 ~ 25GHz
MODE	CCK		
INPUT POWER (SYSTEM)	120Vac, 60 Hz	DETECTOR FUNCTION	Peak(PK) Average (AV)
ENVIRONMENTAL CONDITIONS	25deg. C, 65%RH, 991hPa	TESTED BY: Rush Kao	

ANTENNA POLARITY & TEST DISTANCE: HORIZONTAL AT 3M								
No.	Freq. (MHz)	Emission Level (dBuV/m)	Limit (dBuV/m)	Margin (dB)	Antenna Height (m)	Table Angle (Degree)	Raw Value (dBuV)	Correction Factor (dB/m)
1	*2462.00	108.14 PK			1.00 H	214	73.98	34.16
1	*2462.00	100.06 AV			1.00 H	214	65.90	34.16
2	2483.50	55.25 PK	74.00	-18.75	1.00 H	214	20.99	34.26
2	2483.50	47.17 AV	54.00	-6.83	1.00 H	214	12.91	34.26

ANTENNA POLARITY & TEST DISTANCE: VERTICAL AT 3M								
No.	Freq. (MHz)	Emission Level (dBuV/m)	Limit (dBuV/m)	Margin (dB)	Antenna Height (m)	Table Angle (Degree)	Raw Value (dBuV)	Correction Factor (dB/m)
1	*2462.00	104.99 PK			1.04 V	323	70.83	34.16
1	*2462.00	96.78 AV			1.04 V	323	62.62	34.16
2	2483.50	52.10 PK	74.00	-21.90	1.04 V	323	17.84	34.26
2	2483.50	43.89 AV	54.00	-10.11	1.04 V	323	9.63	34.26

- REMARKS:**
1. Emission level(dBuV/m)=Raw Value(dBuV) + Correction Factor(dB)
 2. Correction Factor(dB/m) = Antenna Factor (dB/m) + Cable Factor (dB)
 3. The other emission levels were very low against the limit.
 4. Margin value = Emission level – Limit value.
 5. “ * “ : Fundamental frequency



EUT	MiniPCI 802.11a/b/g Wireless LAN Card	MODEL	Q802MIAG
CHANNEL	Channel 1	FREQUENCY RANGE	1 ~ 25GHz
MODE	OFDM		
INPUT POWER (SYSTEM)	120Vac, 60 Hz	DETECTOR FUNCTION	Peak(PK) Average (AV)
ENVIRONMENTAL CONDITIONS	25deg. C, 65%RH, 991hPa	TESTED BY: Rush Kao	

ANTENNA POLARITY & TEST DISTANCE: HORIZONTAL AT 3 M								
No.	Freq. (MHz)	Emission Level (dBuV/m)	Limit (dBuV/m)	Margin (dB)	Antenna Height (m)	Table Angle (Degree)	Raw Value (dBuV)	Correction Factor (dB/m)
1	2390.00	43.68 PK	74.00	-30.32	1.00 H	31	9.85	33.83
1	2390.00	34.03AV	54.00	-19.97	1.00 H	31	0.20	33.83
2	*2412.00	92.90 PK			1.00 H	31	58.97	33.93
2	*2412.00	83.25 AV			1.00 H	31	49.32	33.93

ANTENNA POLARITY & TEST DISTANCE: VERTICAL AT 3 M								
No.	Freq. (MHz)	Emission Level (dBuV/m)	Limit (dBuV/m)	Margin (dB)	Antenna Height (m)	Table Angle (Degree)	Raw Value (dBuV)	Correction Factor (dB/m)
1	2390.00	49.12 PK	74.00	-24.88	1.07 V	111	15.29	33.83
1	2390.00	39.44 AV	54.00	-14.56	1.07 V	111	5.61	33.83
2	*2412.00	98.34 PK	74.00	24.34	1.07 V	111	64.41	33.93
2	*2412.00	88.66 AV	54.00	34.66	1.07 V	111	54.73	33.93

- REMARKS:**
1. Emission level(dBuV/m)=Raw Value(dBuV) + Correction Factor(dB)
 2. Correction Factor(dB/m) = Antenna Factor (dB/m) + Cable Factor (dB)
 3. The other emission levels were very low against the limit.
 4. Margin value = Emission level – Limit value.
 5. " * " : Fundamental frequency



EUT	MiniPCI 802.11a/b/g Wireless LAN Card	MODEL	Q802MIAG
CHANNEL	Channel 6	FREQUENCY RANGE	1 ~ 25GHz
MODE	OFDM		
INPUT POWER (SYSTEM)	120Vac, 60 Hz	DETECTOR FUNCTION	Peak(PK) Average (AV)
ENVIRONMENTAL CONDITIONS	25deg. C, 65%RH, 991hPa	TESTED BY: Rush Kao	

ANTENNA POLARITY & TEST DISTANCE: HORIZONTAL AT 3M								
No.	Freq. (MHz)	Emission Level (dBuV/m)	Limit (dBuV/m)	Margin (dB)	Antenna Height (m)	Table Angle (Degree)	Raw Value (dBuV)	Correction Factor (dB/m)
1	*2437.00	94.40 PK			1.00 H	126	60.35	34.05
1	*2437.00	84.72 AV			1.00 H	126	50.67	34.05

ANTENNA POLARITY & TEST DISTANCE: VERTICAL AT 3M								
No.	Freq. (MHz)	Emission Level (dBuV/m)	Limit (dBuV/m)	Margin (dB)	Antenna Height (m)	Table Angle (Degree)	Raw Value (dBuV)	Correction Factor (dB/m)
1	*2437.00	96.99 PK			1.03 V	2	62.94	34.05
1	*2437.00	87.59 AV			1.03 V	2	53.54	34.05

- REMARKS:**
1. Emission level(dBuV/m)=Raw Value(dBuV) + Correction Factor(dB)
 2. Correction Factor(dB/m) = Antenna Factor (dB/m) + Cable Factor (dB)
 3. The other emission levels were very low against the limit.
 4. Margin value = Emission level – Limit value.
 5. “ * “ : Fundamental frequency



EUT	MiniPCI 802.11a/b/g Wireless LAN Card	MODEL	Q802MIAG
CHANNEL	Channel 11	FREQUENCY RANGE	1 ~ 25GHz
MODE	OFDM		
INPUT POWER (SYSTEM)	120Vac, 60 Hz	DETECTOR FUNCTION	Peak(PK) Average (AV)
ENVIRONMENTAL CONDITIONS	25deg. C, 65%RH, 991hPa	TESTED BY: Rush Kao	

ANTENNA POLARITY & TEST DISTANCE: HORIZONTAL AT 3M								
No.	Freq. (MHz)	Emission Level (dBuV/m)	Limit (dBuV/m)	Margin (dB)	Antenna Height (m)	Table Angle (Degree)	Raw Value (dBuV)	Correction Factor (dB/m)
1	*2462.00	96.95 PK			1.00 H	136	62.79	34.16
1	*2462.00	87.18 AV			1.00 H	136	53.02	34.16
2	2483.50	47.73 PK	74.00	-26.27	1.00 H	136	13.47	34.26
2	2483.50	37.96 AV	54.00	-16.04	1.00 H	136	3.70	34.26
3	7386.00	57.99 PK	74.00	-16.01	1.42 H	301	9.82	48.17
3	7386.00	44.28 AV	54.00	-9.72	1.42 H	301	-3.89	48.17

ANTENNA POLARITY & TEST DISTANCE: VERTICAL AT 3M								
No.	Freq. (MHz)	Emission Level (dBuV/m)	Limit (dBuV/m)	Margin (dB)	Antenna Height (m)	Table Angle (Degree)	Raw Value (dBuV)	Correction Factor (dB/m)
1	*2462.00	98.99 PK			1.02 V	89	64.83	34.16
1	*2462.00	89.53 AV			1.02 V	89	55.37	34.16
2	2483.50	49.77 PK	74.00	-24.23	1.02 V	89	15.51	34.26
2	2483.50	40.31 AV	54.00	-13.69	1.02 V	89	6.05	34.26
3	7386.00	57.44 PK	74.00	-16.56	1.03 V	4	9.27	48.17
3	7386.00	44.19 AV	54.00	-9.81	1.03 V	4	-3.98	48.17

- REMARKS:**
1. Emission level(dBuV/m)=Raw Value(dBuV) + Correction Factor(dB)
 2. Correction Factor(dB/m) = Antenna Factor (dB/m) + Cable Factor (dB)
 3. The other emission levels were very low against the limit.
 4. Margin value = Emission level – Limit value.
 5. “ * “ : Fundamental frequency



4.3 6dB BANDWIDTH MEASUREMENT

4.3.1 LIMITS OF 6dB BANDWIDTH MEASUREMENT

The minimum of 6dB Bandwidth Measurement is 0.5 MHz.

4.3.2 TEST INSTRUMENTS

Description & Manufacturer	Model No.	Serial No.	Calibrated Until
SPECTRUM ANALYZER	FSEK30	100049	Aug. 12, 2005

NOTE:

The calibration interval of the above test instruments is 12 months and the calibrations are traceable to NML/ROC and NIST/USA.

4.3.3 TEST PROCEDURE

The transmitter output was connected to the spectrum analyzer through an attenuator. The bandwidth of the fundamental frequency was measured by spectrum analyzer with 100kHz RBW and 100kHz VBW. The 6dB bandwidth is defined as the total spectrum the power of which is higher than peak power minus 6 dB.

4.3.4 DEVIATION FROM TEST STANDARD

No deviation

4.3.5 TEST SETUP

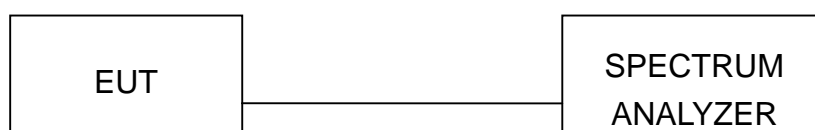

4.3.6 EUT OPERATING CONDITIONS

The software provided by client to enable the EUT under transmission condition continuously at lowest, middle and highest channel frequencies individually.



4.3.7 TEST RESULTS

EUT	MiniPCI 802.11a/b/g Wireless LAN Card	MODEL	Q802MIAG
MODE	CCK	INPUT POWER (SYSTEM)	120Vac, 60 Hz
ENVIRONMENTAL CONDITIONS	25deg. C, 60%RH, 991hPa	TESTED BY	Rush Kao

CHANNEL	CHANNEL FREQUENCY (MHz)	6dB BANDWIDTH (MHz)	MINIMUM LIMIT (MHz)	PASS/FAIL
1	2412	11.50	0.5	PASS
6	2437	11.46	0.5	PASS
11	2462	11.46	0.5	PASS



CH1

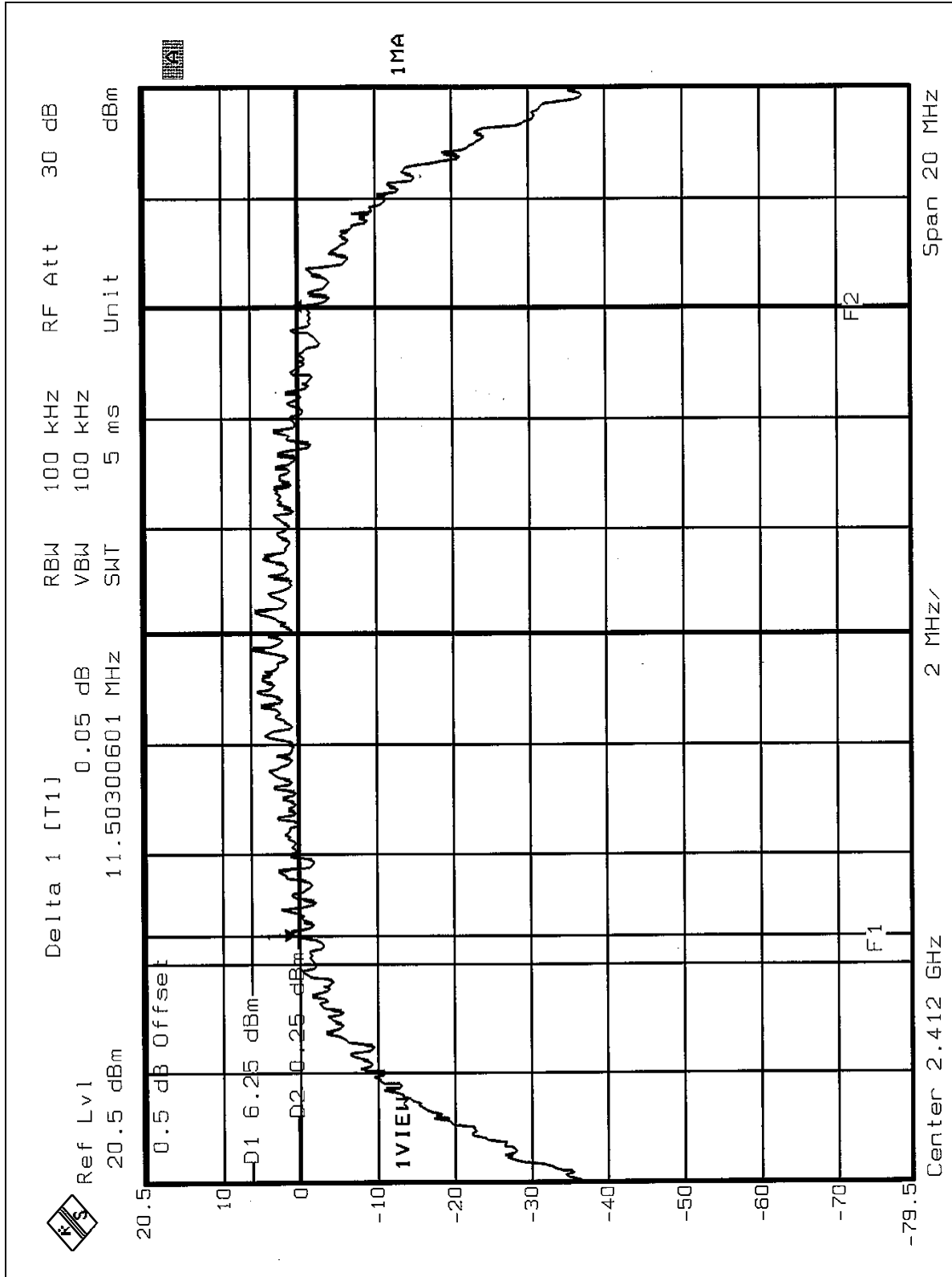



CH6

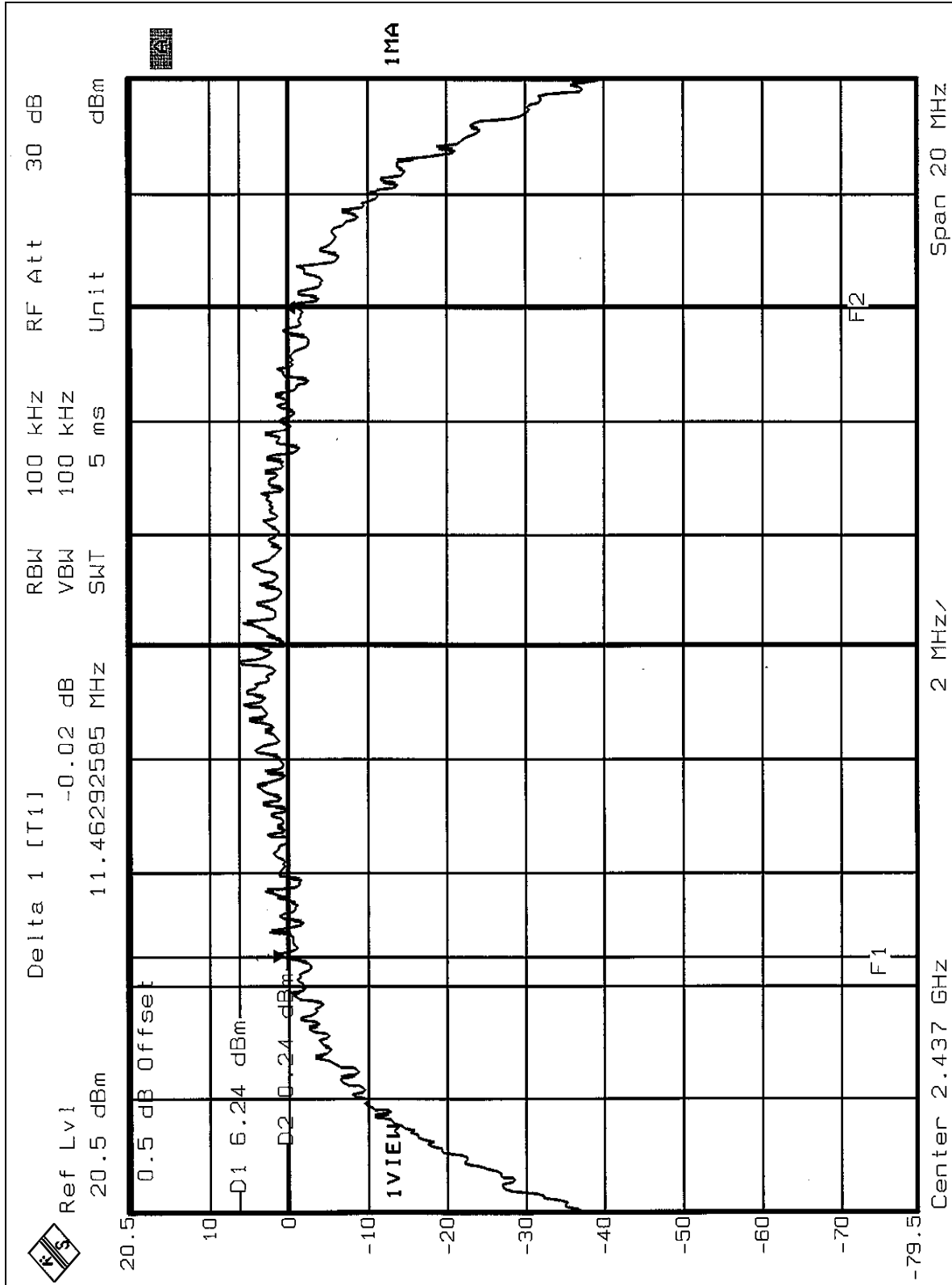



EUT	MiniPCI 802.11a/b/g Wireless LAN Card	MODEL	Q802MIAG
MODE	OFDM	INPUT POWER (SYSTEM)	120Vac, 60 Hz
ENVIRONMENTAL CONDITIONS	25deg. C, 60%RH, 991hPa	TESTED BY	Rush Kao

CHANNEL	CHANNEL FREQUENCY (MHz)	6dB BANDWIDTH (MHz)	MINIMUM LIMIT (MHz)	PASS/FAIL
1	2412	16.39	0.5	PASS
6	2437	16.43	0.5	PASS
11	2462	16.43	0.5	PASS



CH1

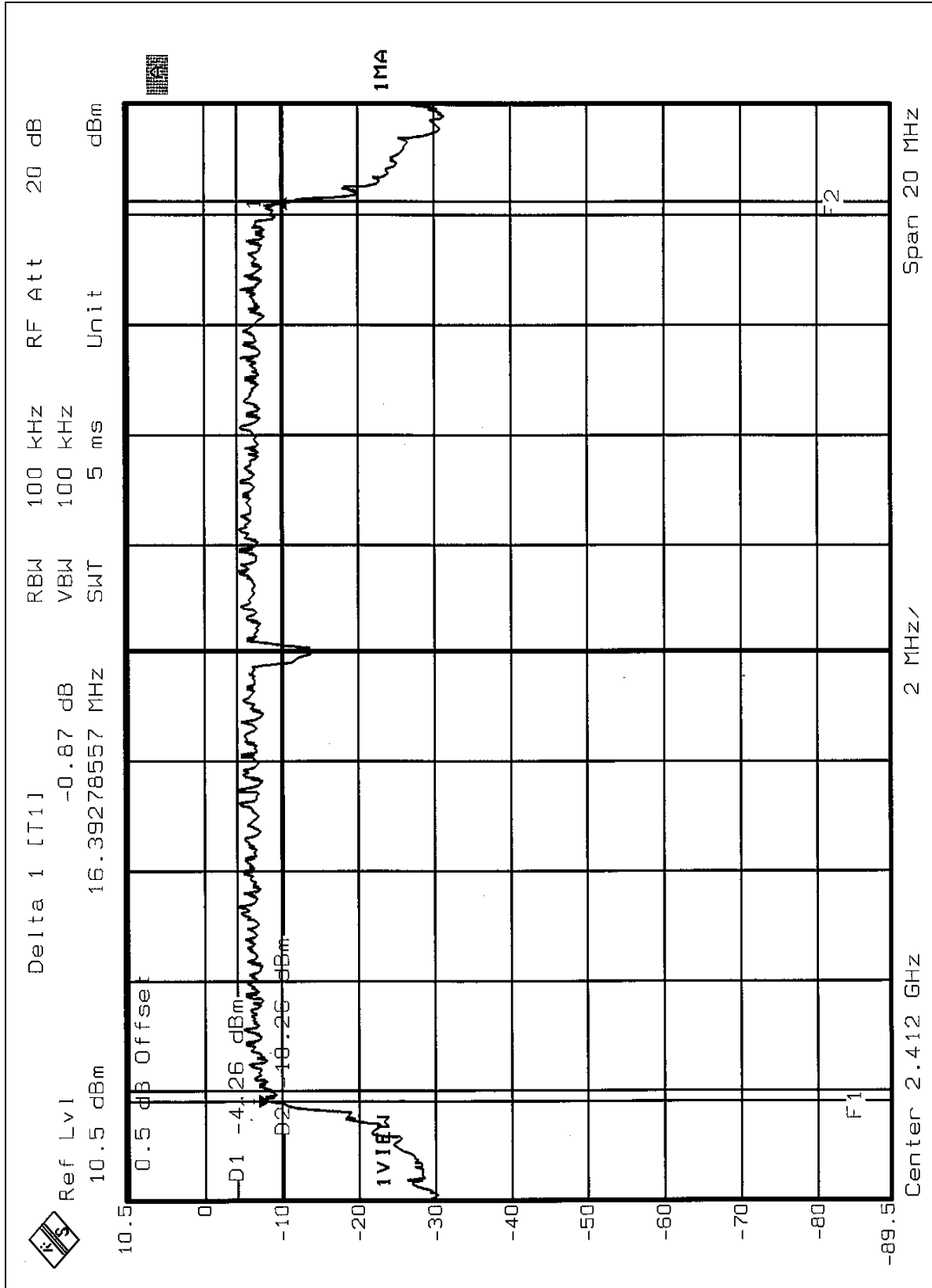



CH6

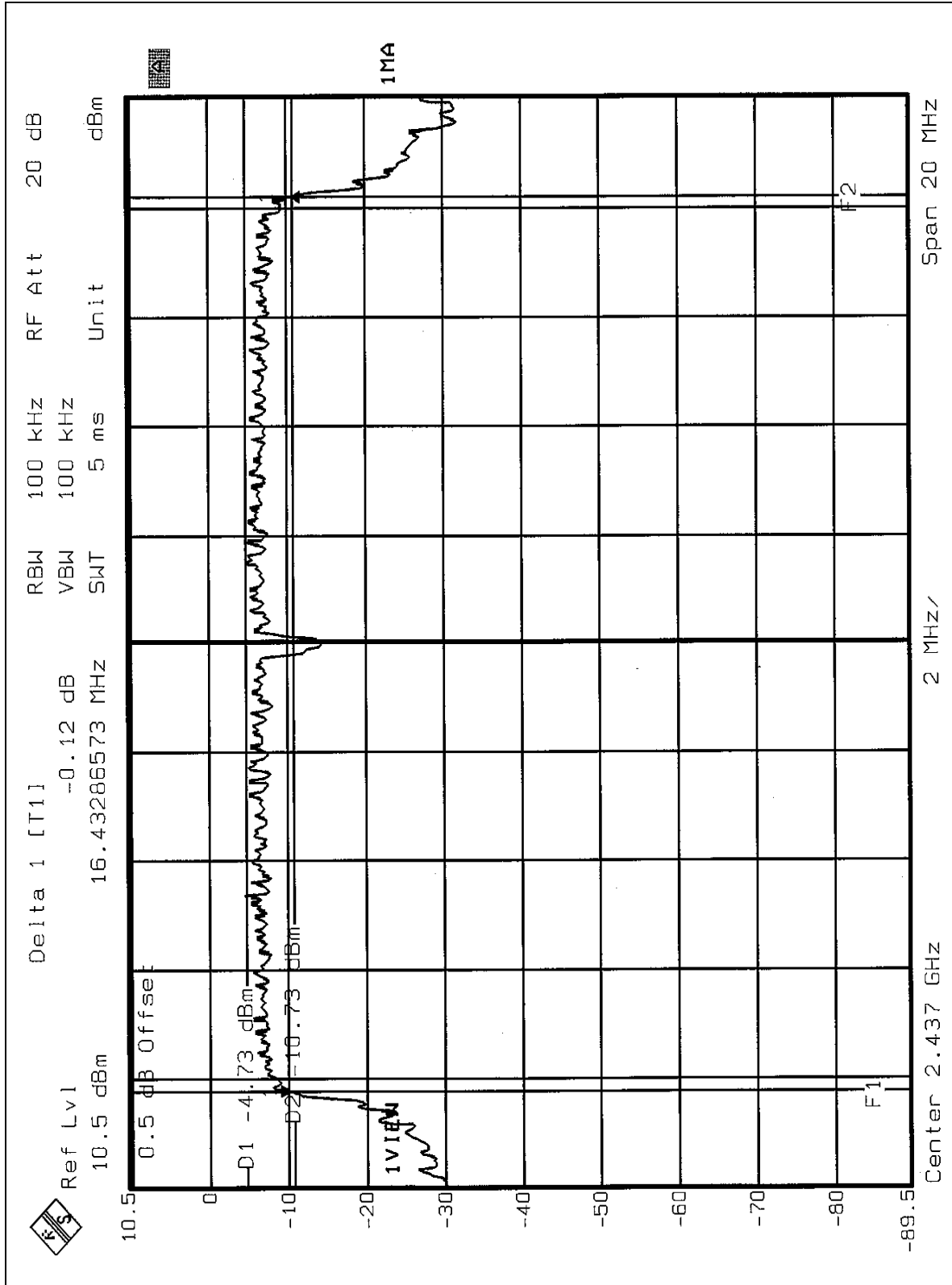



CH11

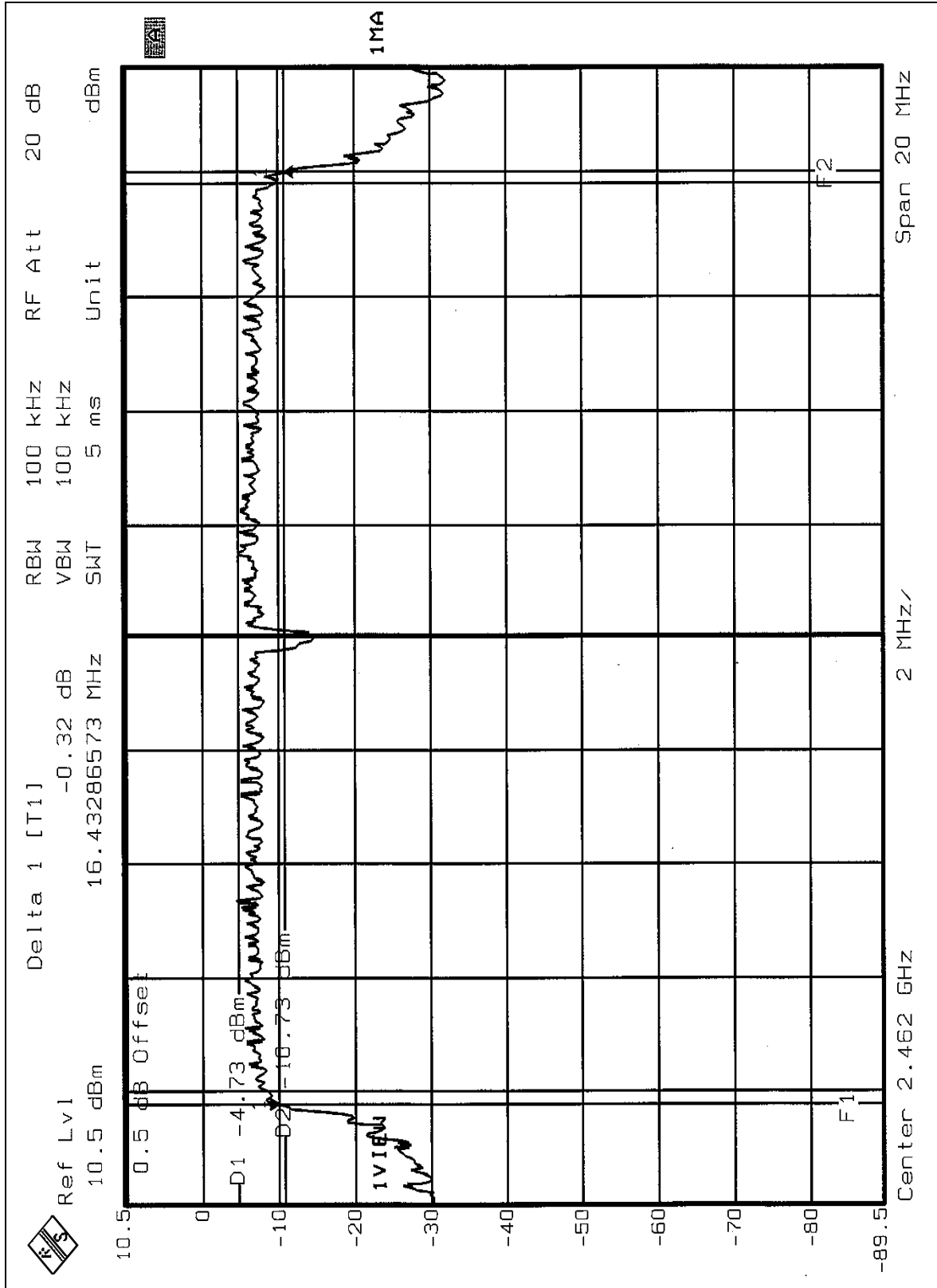



4.4 MAXIMUM PEAK OUTPUT POWER

4.4.1 LIMITS OF MAXIMUM PEAK OUTPUT POWER MEASUREMENT

The Maximum Peak Output Power Measurement is 30dBm.

4.4.2 INSTRUMENTS

Description & Manufacturer	Model No.	Serial No.	Calibrated Until
R&S SPECTRUM ANALYZER	FSEK30	100049	Aug. 12, 2005
AGILENT SIGNAL GENERATOR	E8257C	MY43320668	Dec. 31, 2004
TEKTRONIX OSCILLOSCOPE	TDS 1012	C019167	Feb. 01, 2005
NARDA DETECTOR	4503A	FSCM99899	NA

NOTE:

The calibration interval of the above test instruments is 12 months and the calibrations are traceable to NML/ROC and NIST/USA..



4.4.3 TEST PROCEDURES

1. A detector was used on the output port of the EUT. An oscilloscope was used to read the response of the detector.
2. Replaced the EUT by the signal generator. The center frequency of the S.G was adjusted to the center frequency of the measured channel.
3. Adjusted the power to have the same reading on oscilloscope. Record the power level.

4.4.4 TEST SETUP

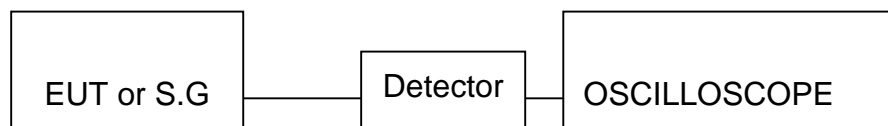

4.4.5 EUT OPERATING CONDITIONS

Same as Item 4.3.6



4.4.6 TEST RESULTS

EUT	MiniPCI 802.11a/b/g Wireless LAN Card	MODEL	Q802MIAG
INPUT POWER (SYSTEM)	120Vac, 60Hz	ENVIRONMENTAL CONDITIONS	25deg.C, 60%RH, 991hPa
MODE	CCK	TESTED BY	Rush Kao

CHANNEL	CHANNEL FREQUENCY (MHz)	PEAK POWER OUTPUT (mW)	PEAK POWER OUTPUT (dBm)	PEAK POWER LIMIT (dBm)	PASS/FAIL
1	2412	51.286	17.10	30	PASS
6	2437	50.119	17.00	30	PASS
11	2462	52.481	17.20	30	PASS

EUT	MiniPCI 802.11a/b/g Wireless LAN Card	MODEL	Q802MIAG
INPUT POWER (SYSTEM)	120Vac, 60Hz	ENVIRONMENTAL CONDITIONS	25deg.C, 60%RH, 991hPa
MODE	OFDM	TESTED BY	Rush Kao

CHANNEL	CHANNEL FREQUENCY (MHz)	PEAK POWER OUTPUT (mW)	PEAK POWER OUTPUT (dBm)	PEAK POWER LIMIT (dBm)	PASS/FAIL
1	2412	16.218	12.10	30	PASS
6	2437	15.849	12.00	30	PASS
11	2462	16.596	12.20	30	PASS



4.5 POWER SPECTRAL DENSITY MEASUREMENT

4.5.1 LIMITS OF POWER SPECTRAL DENSITY MEASUREMENT

The Maximum of Power Spectral Density Measurement is 8dBm.

4.5.2 TEST INSTRUMENTS

Description & Manufacturer	Model No.	Serial No.	Calibrated Until
SPECTRUM ANALYZER	FSEK30	100049	Aug. 12, 2005

NOTE:

The calibration interval of the above test instruments is 12 months and the calibrations are traceable to NML/ROC and NIST/USA.

4.5.3 TEST PROCEDURE

The transmitter output was connected to the spectrum analyzer through an attenuator, the bandwidth of the fundamental frequency was measured with the spectrum analyzer using 3 kHz RBW and 30 kHz VBW, set sweep time = span/3 kHz. The power spectral density was measured and recorded.

The sweep time is allowed to be longer than span/3 kHz for a full response of the mixer in the spectrum analyzer.

4.5.4 DEVIATION FROM TEST STANDARD

No deviation

4.5.5 TEST SETUP

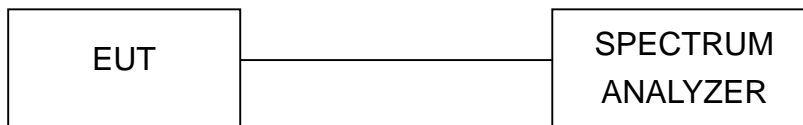

4.5.6 EUT OPERATING CONDITION

Same as Item 4.3.6



4.5.7 TEST RESULTS

EUT	MiniPCI 802.11a/b/g Wireless LAN Card	MODEL	Q802MIAG
INPUT POWER (SYSTEM)	120Vac, 60Hz	ENVIRONMENTAL CONDITIONS	25deg.C, 60%RH, 991hPa
MODE	CCK	TESTED BY	Rush Kao

CHANNEL	CHANNEL FREQUENCY (MHz)	RF POWER LEVEL IN 3kHz BW (dBm)	MAXIMUM LIMIT (dBm)	PASS/FAIL
1	2412	-7.89	8	PASS
6	2437	-8.18	8	PASS
11	2462	-8.16	8	PASS



CH1

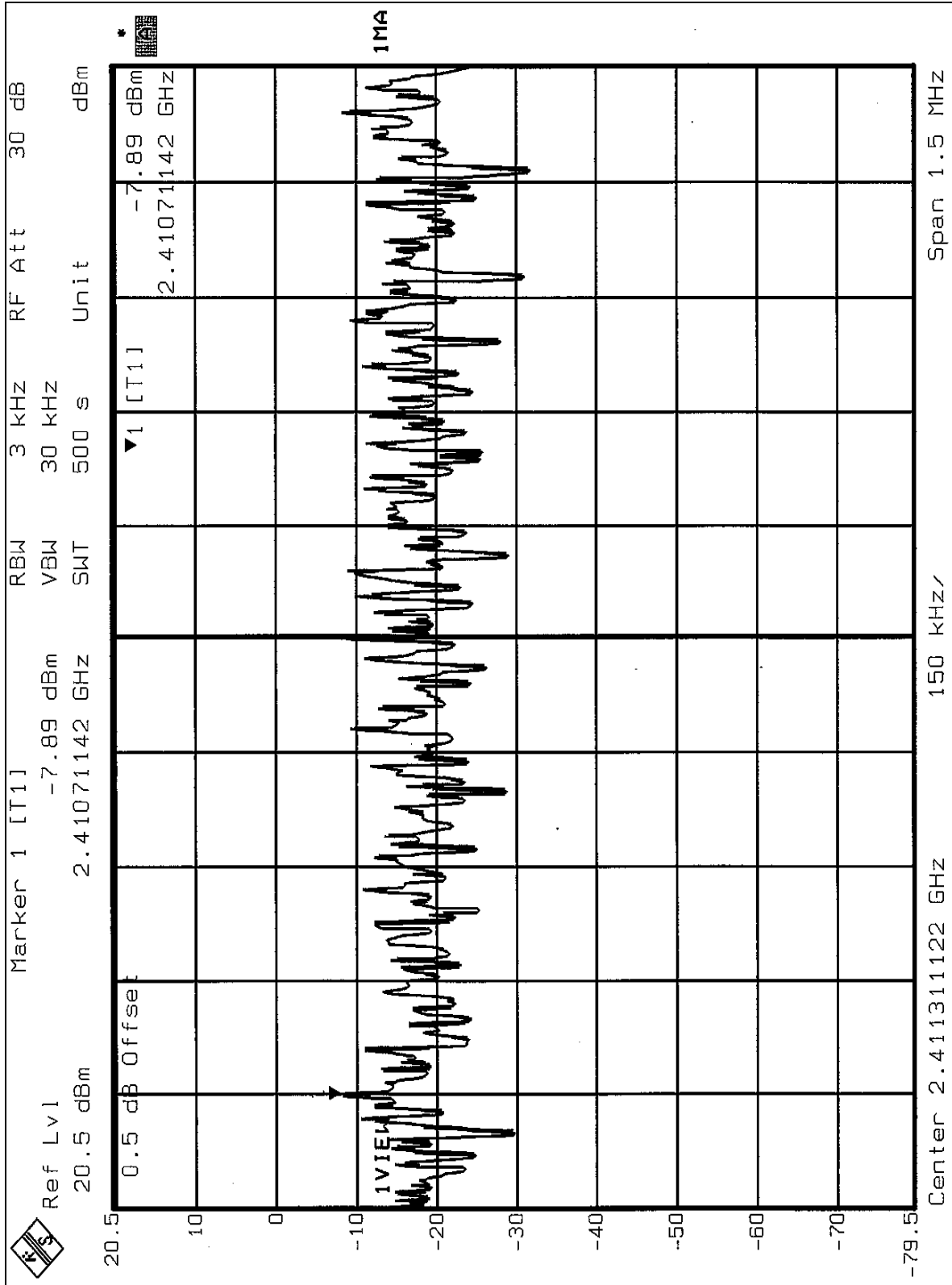



CH6

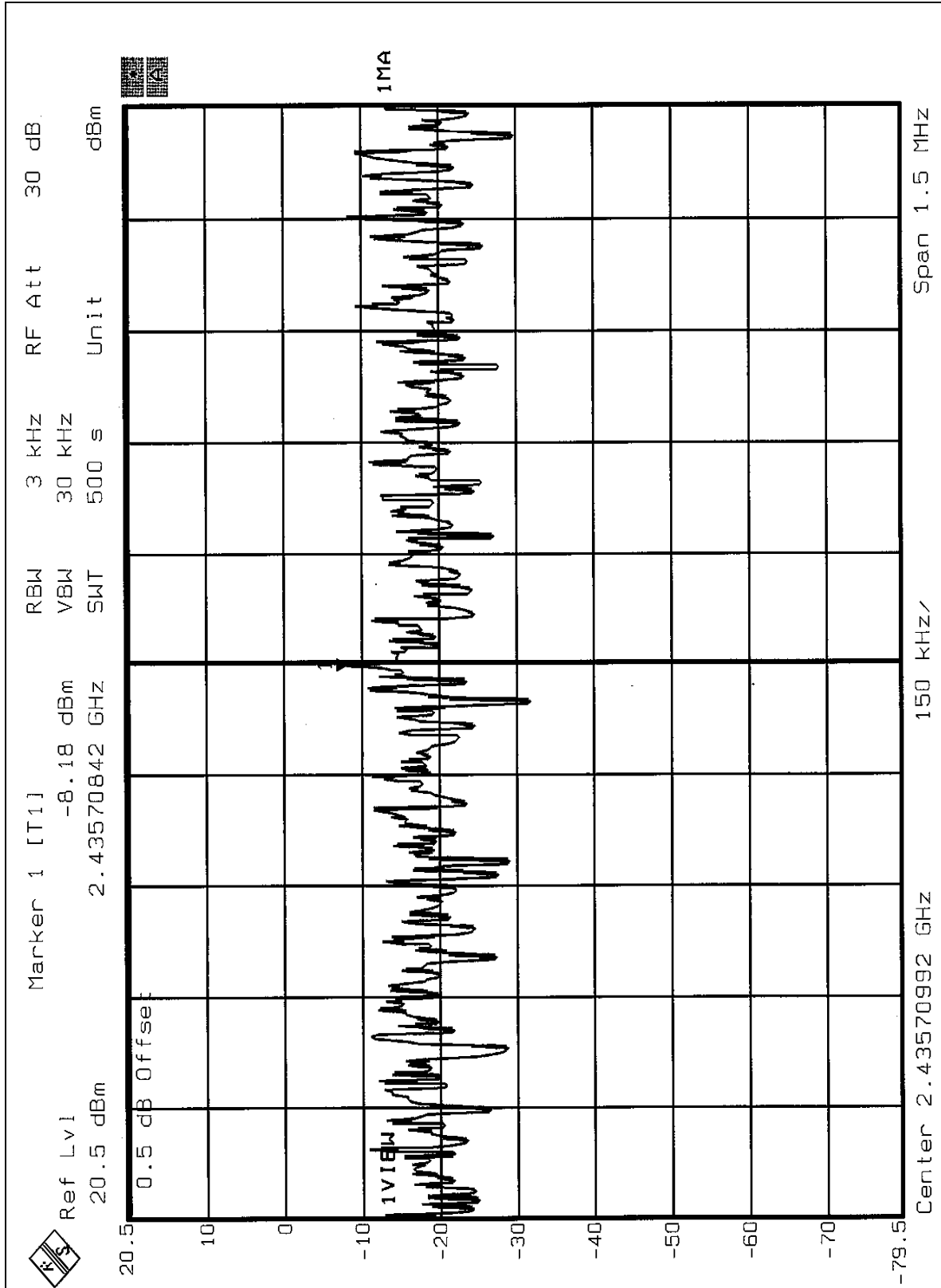



CH11

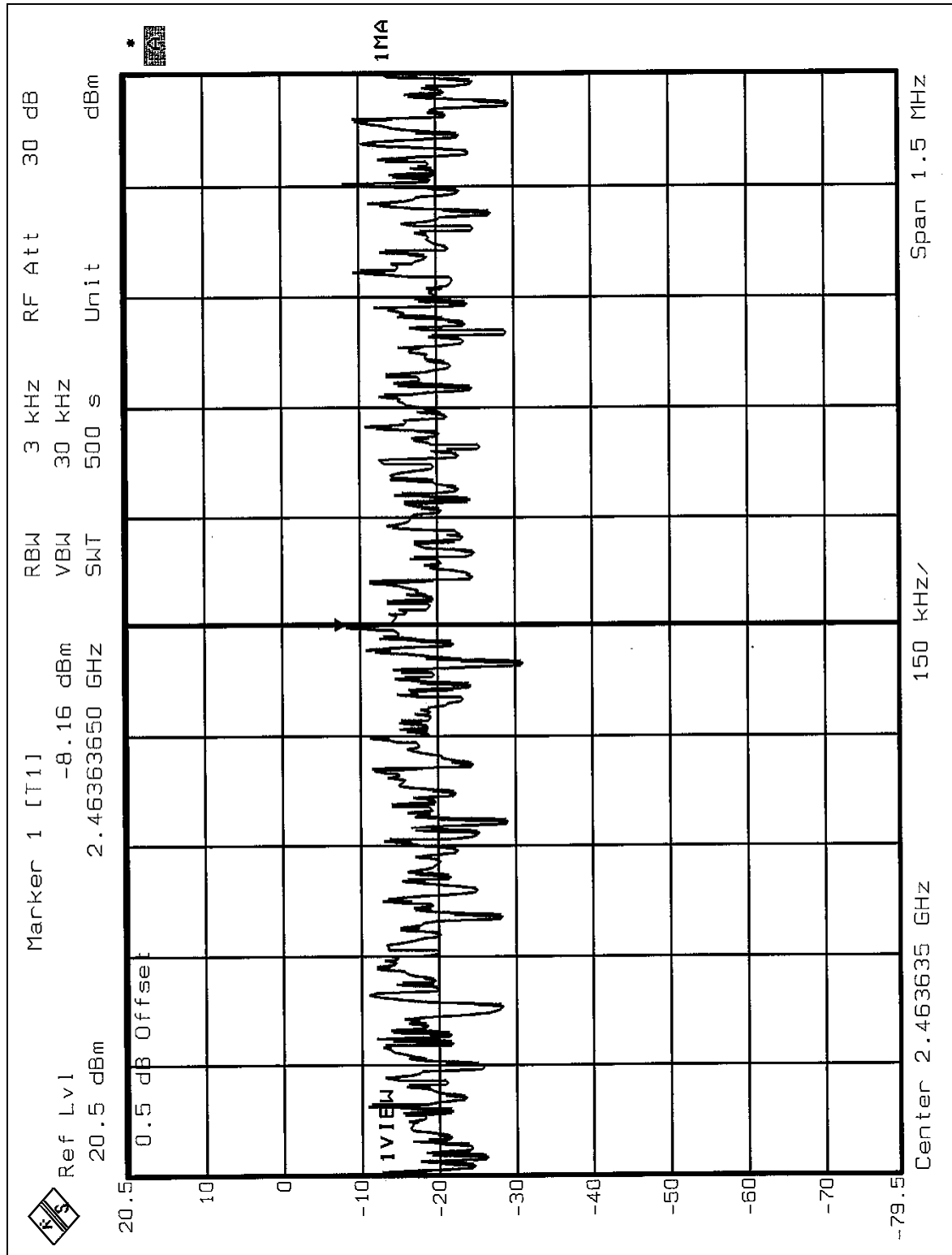



EUT	MiniPCI 802.11a/b/g Wireless LAN Card	MODEL	Q802MIAG
INPUT POWER (SYSTEM)	120Vac, 60Hz	ENVIRONMENTAL CONDITIONS	25deg.C, 60%RH, 991hPa
MODE	OFDM	TESTED BY	Rush Kao

CHANNEL	CHANNEL FREQUENCY (MHz)	RF POWER LEVEL IN 3kHz BW (dBm)	MAXIMUM LIMIT (dBm)	PASS/FAIL
1	2412	-18.70	8	PASS
6	2437	-18.86	8	PASS
11	2462	-18.70	8	PASS



CH1

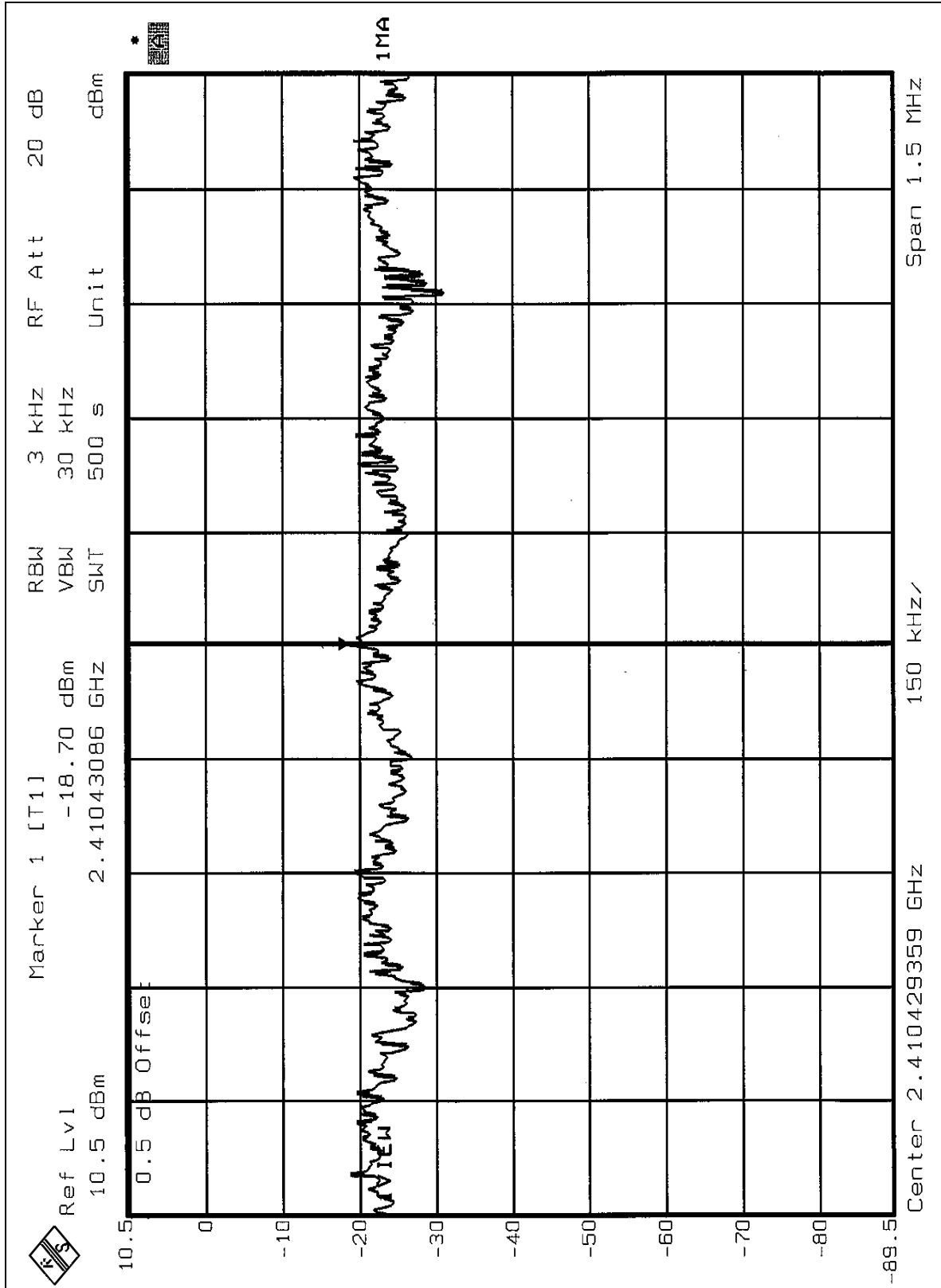



CH6

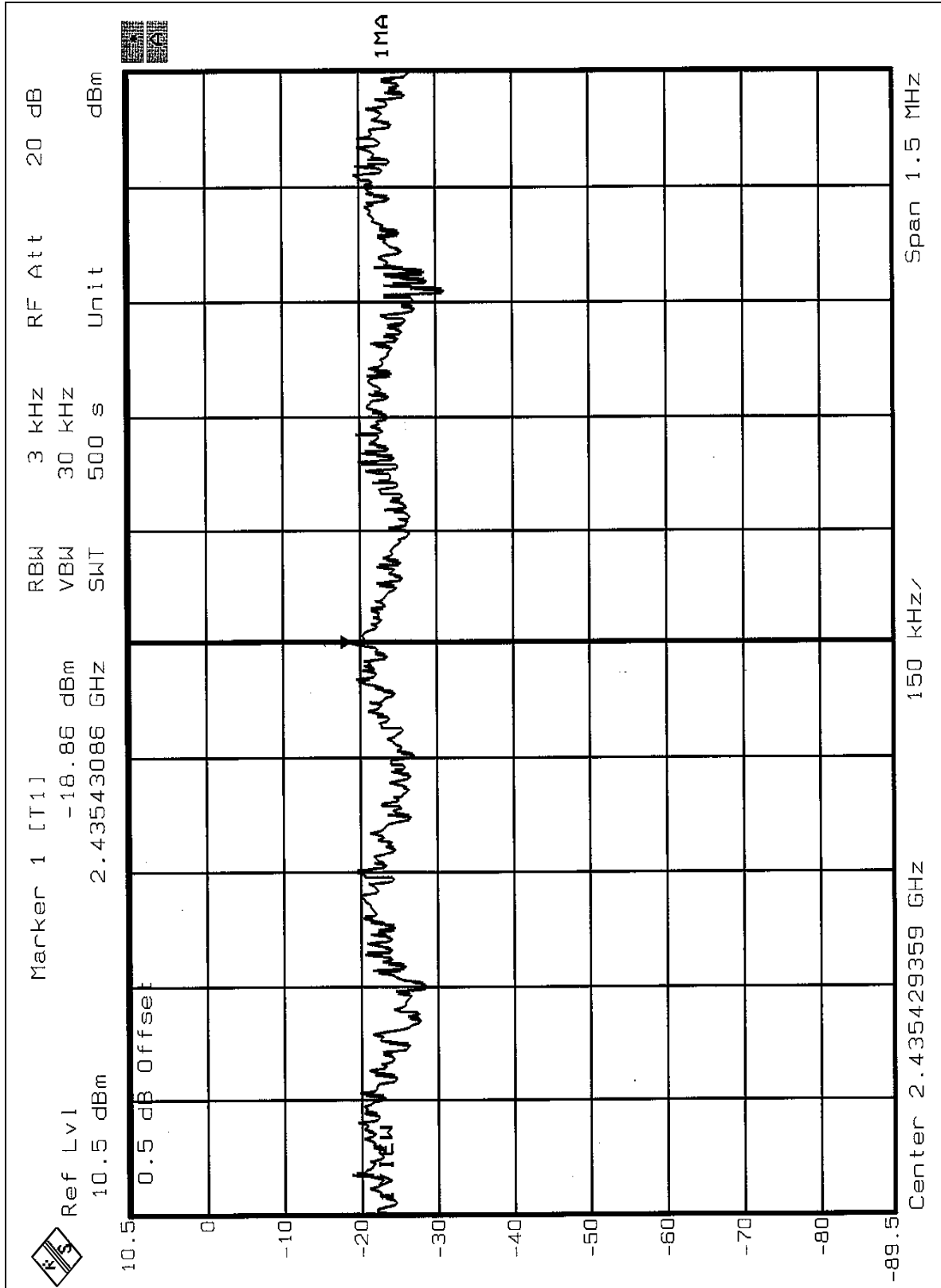



CH11

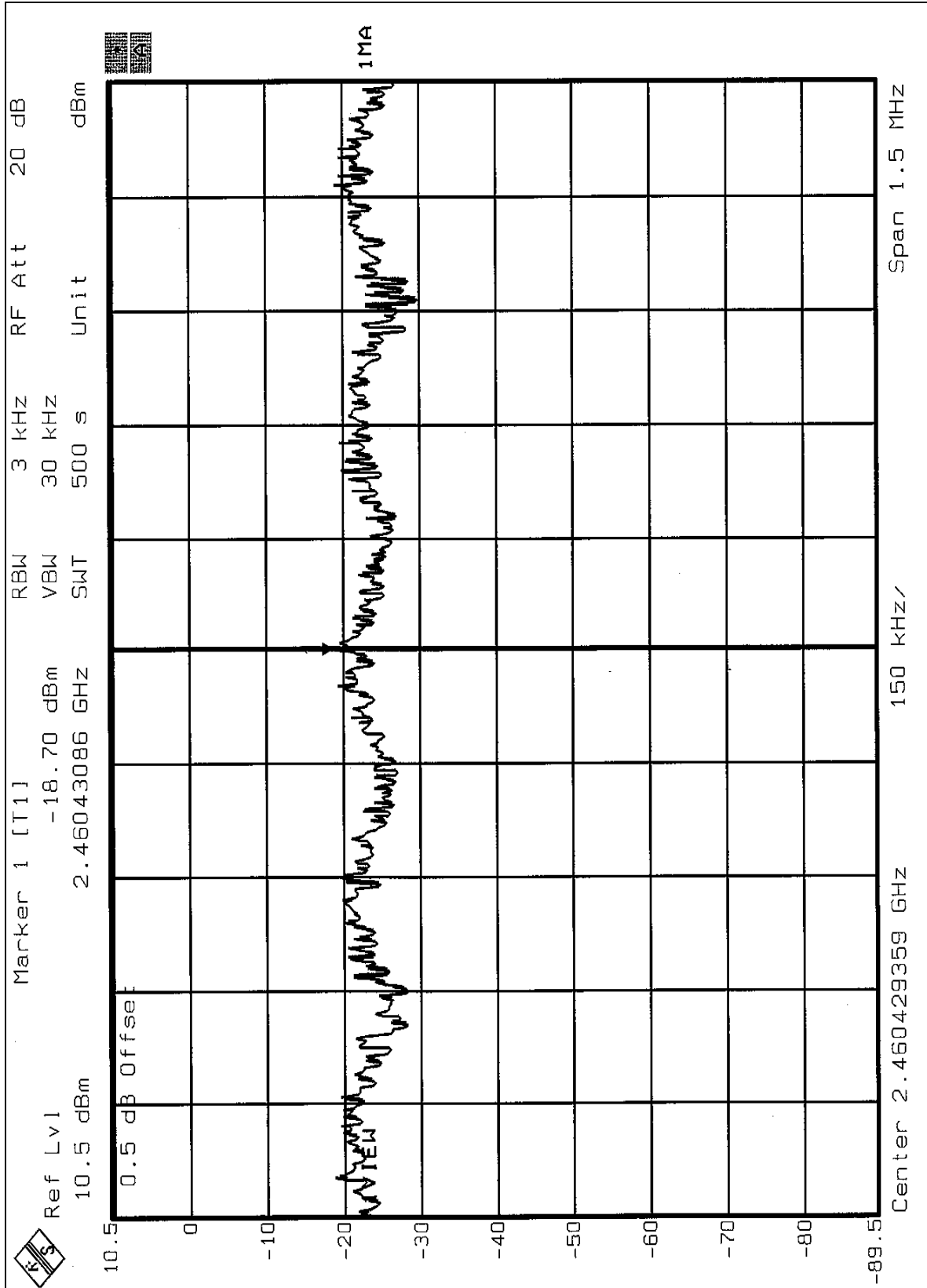



4.6 BAND EDGES MEASUREMENT

4.6.1 LIMITS OF BAND EDGES MEASUREMENT

Below -20dB of the highest emission level of operating band (in 100KHz Resolution Bandwidth).

4.6.2 TEST INSTRUMENTS

Description & Manufacturer	Model No.	Serial No.	Calibrated Until
SPECTRUM ANALYZER	FSEK30	100049	Aug. 12, 2005

NOTE:

The calibration interval of the above test instruments is 12 months and the calibrations are traceable to NML/ROC and NIST/USA.

4.6.3 TEST PROCEDURE

The transmitter output was connected to the spectrum analyzer via a low lose cable. Set both RBW and VBW of spectrum analyzer to 100 kHz with suitable frequency span including 100 MHz bandwidth from band edge. The band edges was measured and recorded.

4.6.4 DEVIATION FROM TEST STANDARD

No deviation

4.6.5 EUT OPERATING CONDITION

Same as Item 4.3.6



4.6.6 TEST RESULTS

The spectrum plots are attached on the following 8 pages. D2 line indicates the highest level, and D1 line indicates the 20dB offset below D2. It shows compliance with the requirement in part 15.247(C).

NOTE 1: The band edge emission plot of CCK technique on page 58 show 52.36dB delta between carrier maximum power and local maximum emission in restrict band (2.3856GHz). The emission of carrier strength list in the test result of channel 1 at the item 4.2.7 is 99.42dBuV/m, so the maximum field strength in restrict band is $99.42 - 52.36 = 47.06$ dBuV/m which is under 54dBuV/m limit.

NOTE 2: The band edge emission plot of CCK technique on page 60 show 52.68dB delta between carrier maximum power and local maximum emission in restrict band (2.4863GHz). The emission of carrier strength list in the test result of channel 11 at the item 4.2.7 is 100.06dBuV/m, so the maximum field strength in restrict band is $100.06 - 52.68 = 47.38$ dBuV/m which is under 54dBuV/m limit.

NOTE 3: The band edge emission plot of OFDM technique on page 62 show 46.95dB delta between carrier maximum power and local maximum emission in restrict band (2.3756GHz). The emission of carrier strength list in the test result of channel 1 at the item 4.2.7 is 88.66dBuV/m, so the maximum field strength in restrict band is $88.66 - 46.95 = 41.71$ dBuV/m which is under 54dBuV/m limit.

NOTE 4: The band edge emission plot of OFDM technique on page 64 show 45.83dB delta between carrier maximum power and local maximum emission in restrict band (2.4987GHz). The emission of carrier strength list in the test result of channel 11 at the item 4.2.7 is 89.53dBuV/m, so the maximum field strength in restrict band is $89.53 - 45.83 = 43.70$ dBuV/m which is under 54dBuV/m limit.

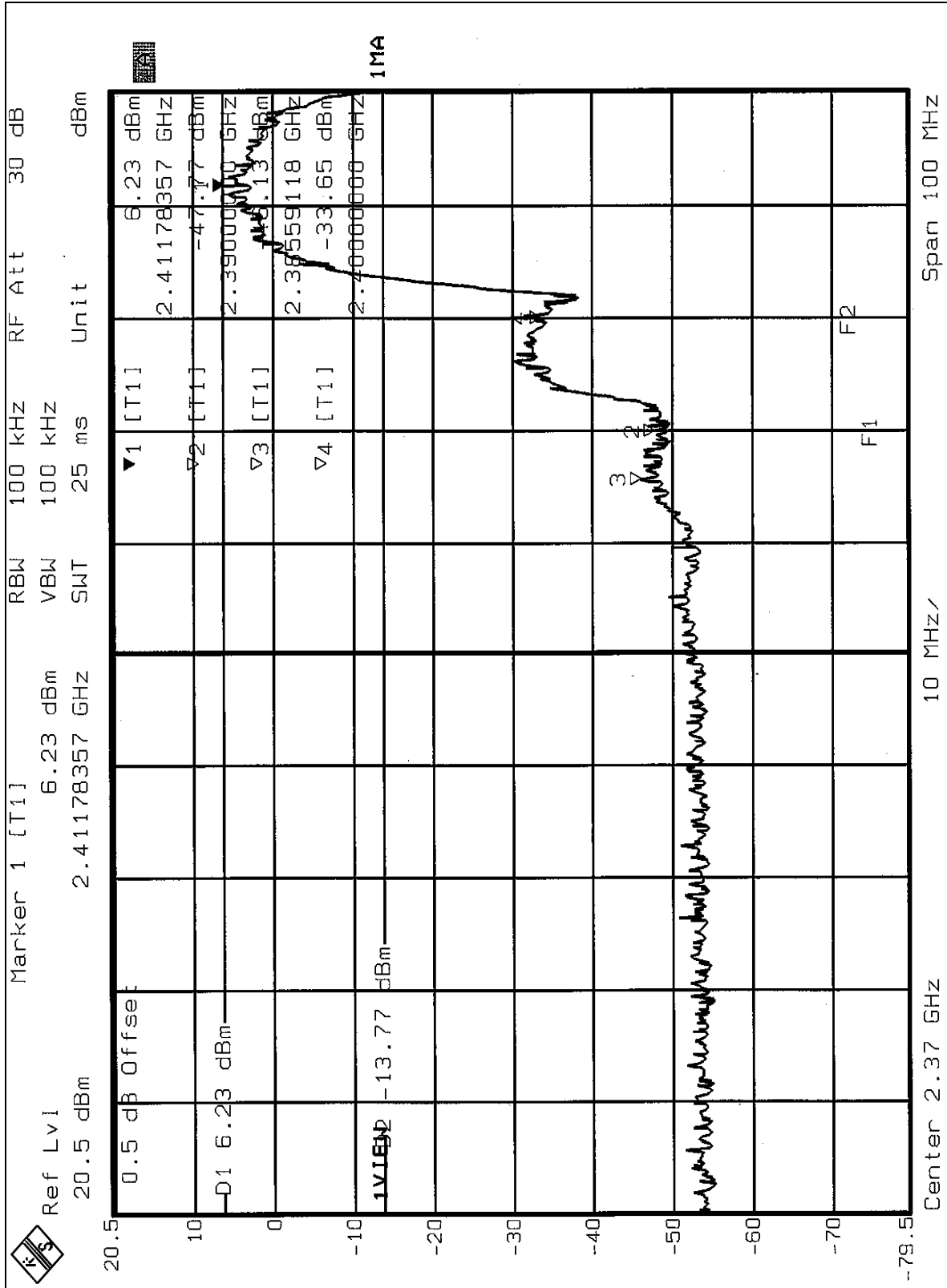

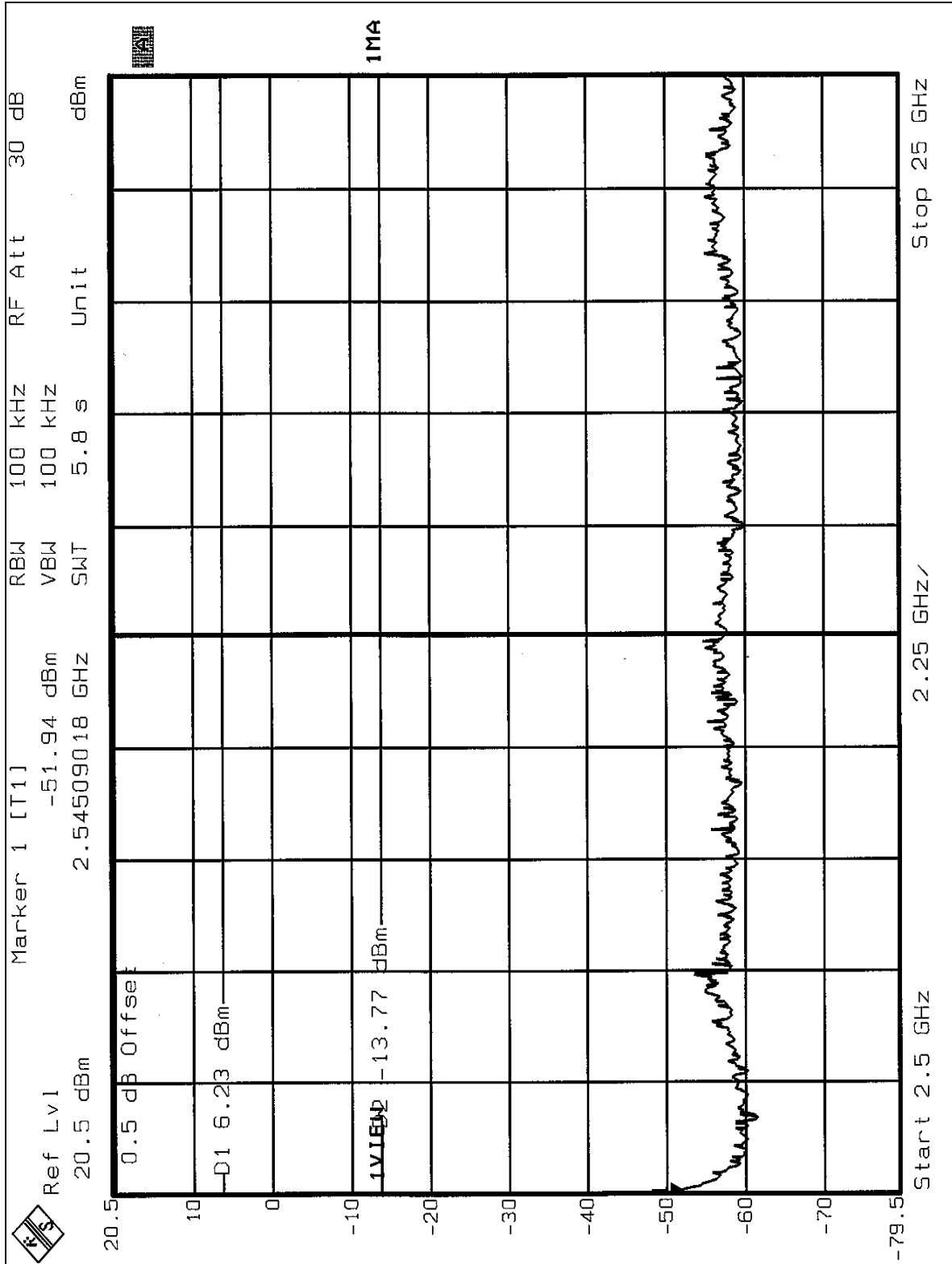

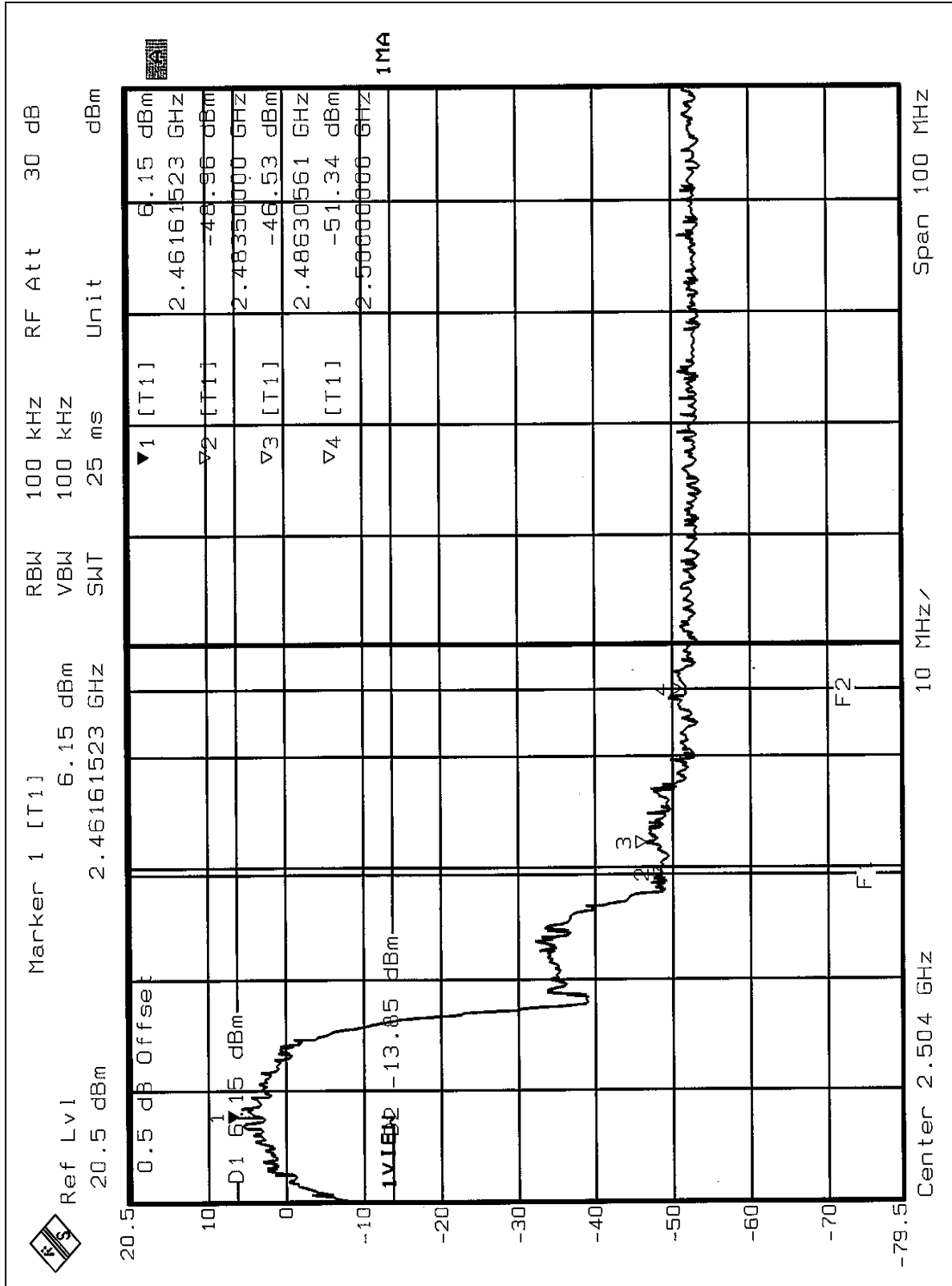

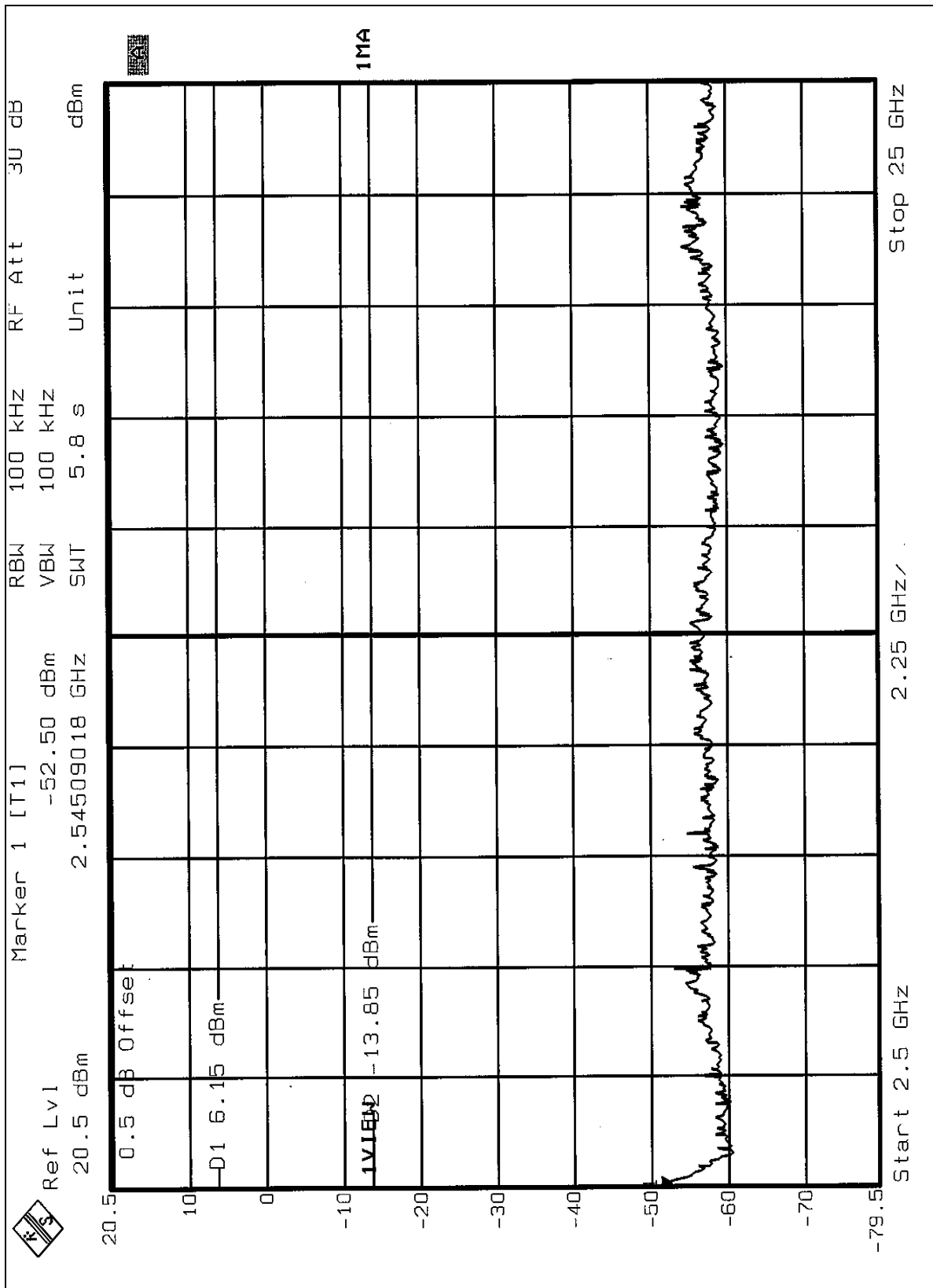

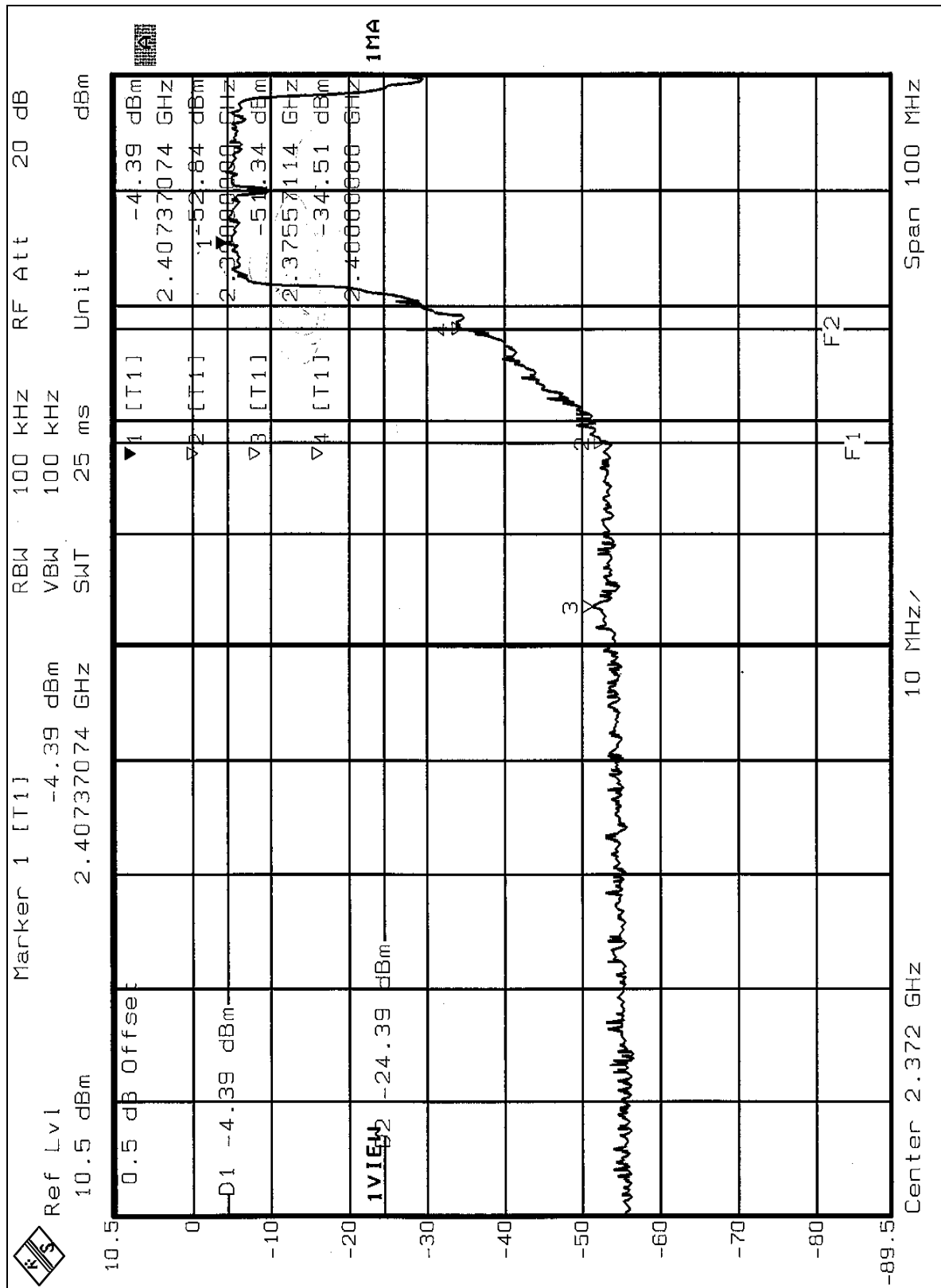

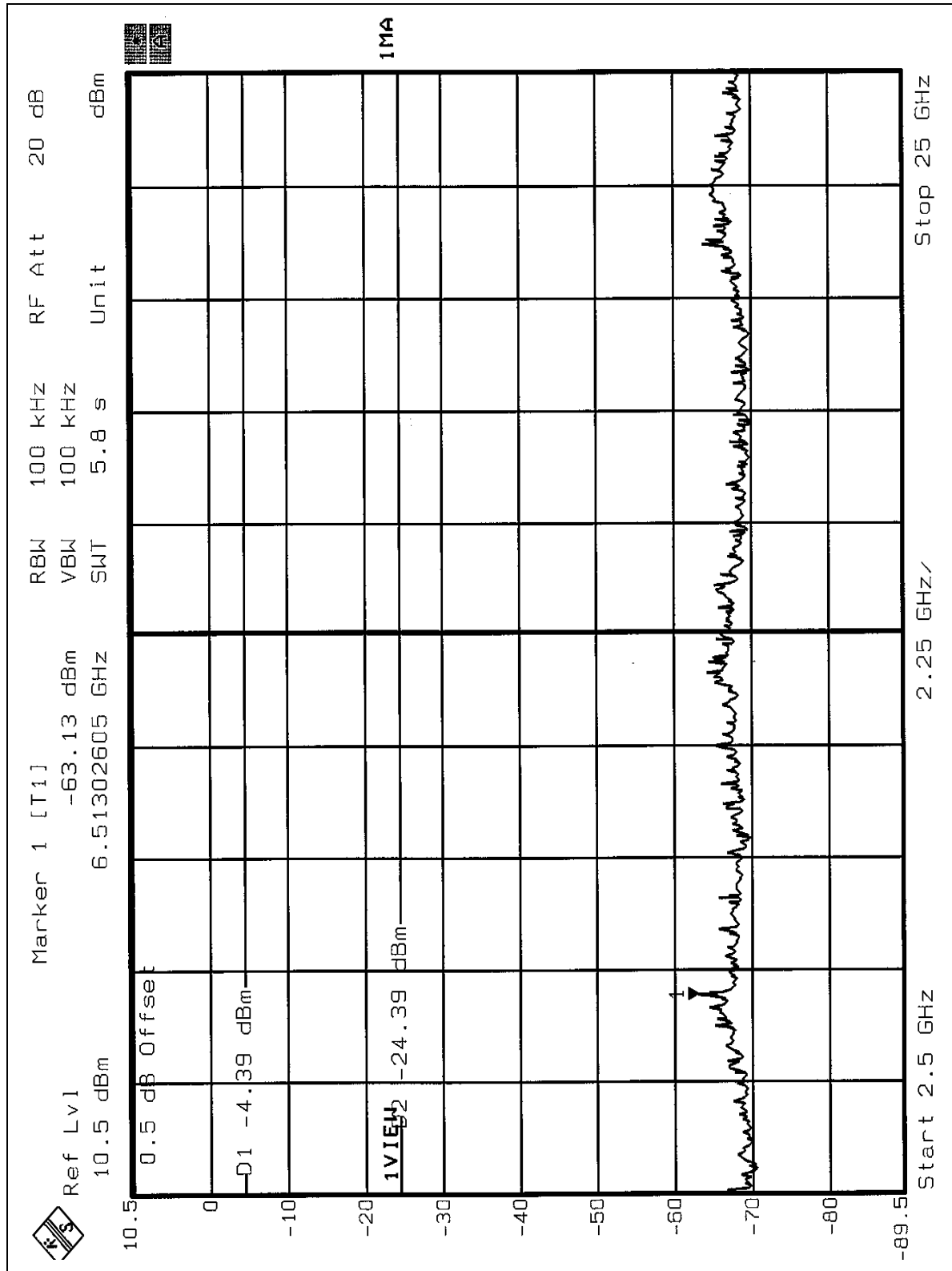

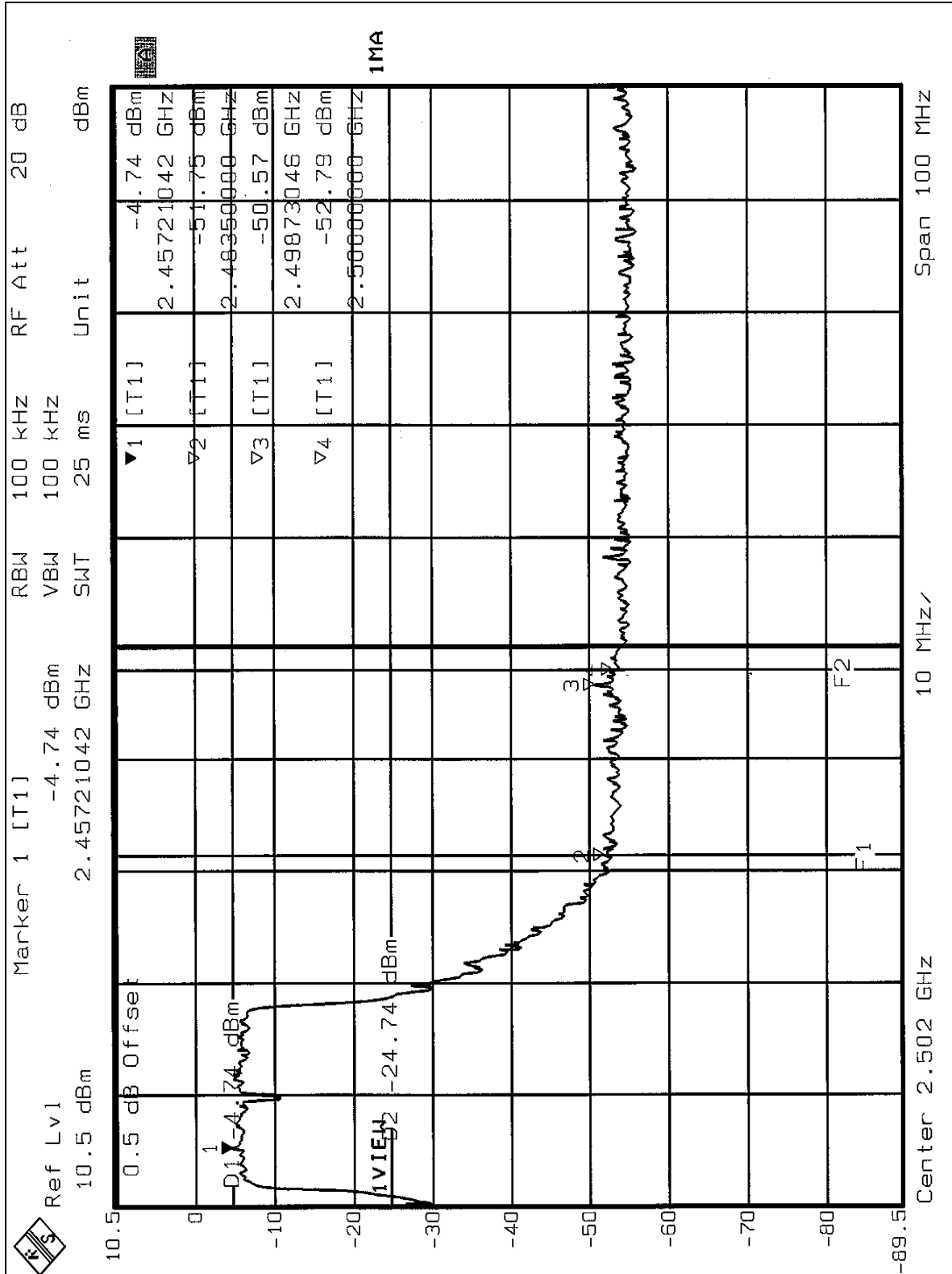

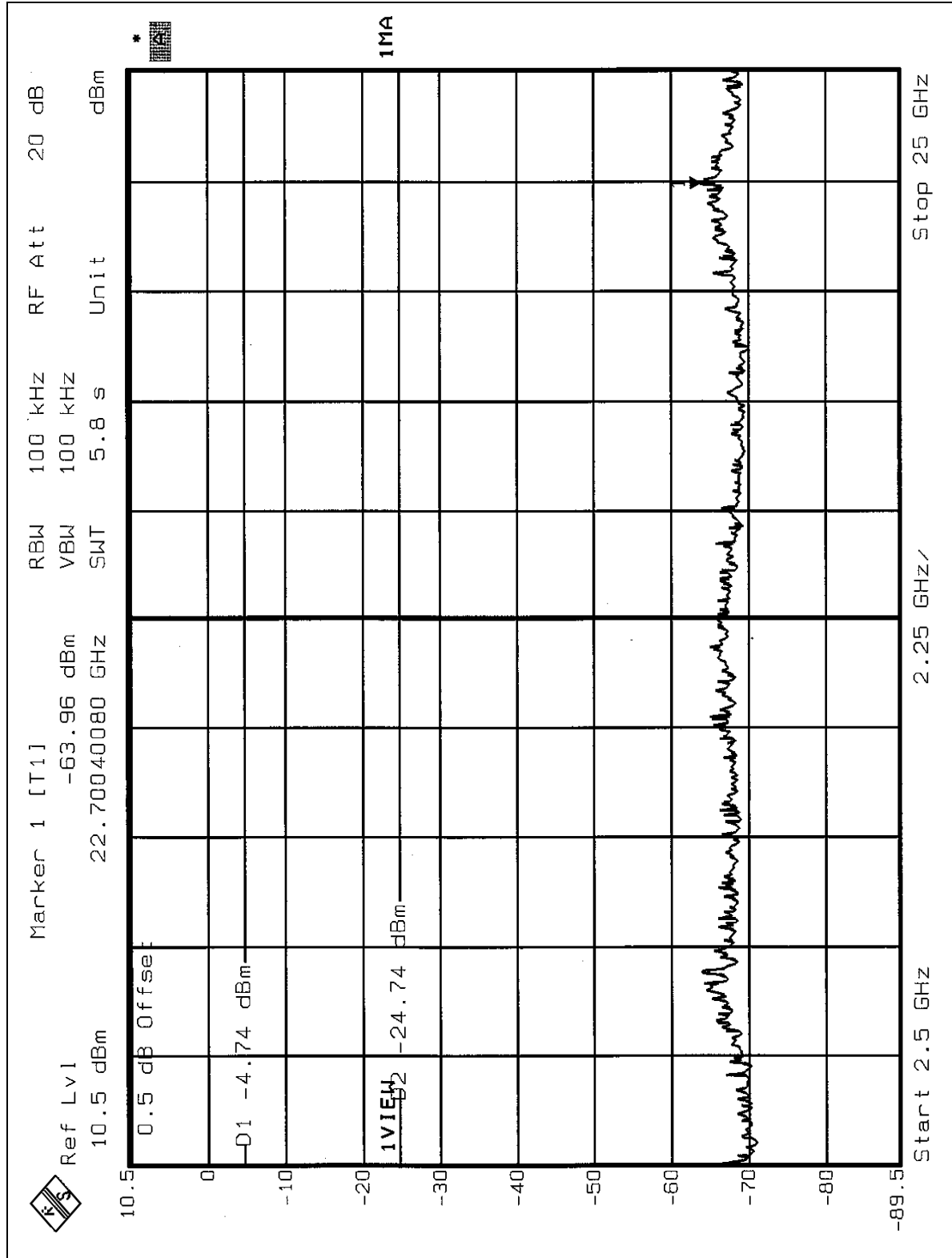



4.7 ANTENNA REQUIREMENT

4.7.1 STANDARD APPLICABLE

For intentional device, according to FCC 47 CFR Section 15.203, an intentional radiator shall be designed to ensure that no antenna other than that furnished by the responsible party shall be used with the device. And according to FCC 47 CFR Section 15.247 (b), if transmitting antennas of directional gain greater than 6dBi are used, the power shall be reduced by the amount in dB that the directional gain of the antenna exceeds 6dBi.

4.7.2 ANTENNA CONNECTED CONSTRUCTION

The antenna used in this product is Inverted F antenna with UFL connector. The maximum Gain of the antenna is 0dBi.



5. TEST TYPES AND RESULTS (FOR PART 802.11a)

5.1 CONDUCTED EMISSION MEASUREMENT

5.1.1 LIMITS OF CONDUCTED EMISSION MEASUREMENT

FREQUENCY OF EMISSION (MHz)	CONDUCTED LIMIT (dBµV)	
	Quasi-peak	Average
0.15-0.5	66 to 56	56 to 46
0.5-5	56	46
5-30	60	50

- NOTE:**
1. The lower limit shall apply at the transition frequencies.
 2. The limit decreases in line with the logarithm of the frequency in the range of 0.15 to 0.50 MHz.
 3. All emanations from a class A/B digital device or system, including any network of conductors and apparatus connected thereto, shall not exceed the level of field strengths specified above.

5.1.2 TEST INSTRUMENTS

DESCRIPTION & MANUFACTURER	MODEL NO.	SERIAL NO.	CALIBRATED UNTIL
Test Receiver ROHDE & SCHWARZ	ESCS30	100288	Dec. 11, 2004
RF signal cable Woken	5D-FB	Cable-HyC02-01	Mar. 07, 2005
LISN ROHDE & SCHWARZ	ESH2-Z5	100100	Mar. 10, 2005
LISN ROHDE & SCHWARZ	ESH3-Z5	100311	Mar. 04, 2005
Software ADT	ADT_Cond_V3	NA	NA

- NOTE:**
1. The calibration interval of the above test instruments is 12 months and the calibrations are traceable to NML/ROC and NIST/USA.
 2. The test was performed in HwaYa Shielded Room 2.
 3. The VCCI Site Registration No. is C-2047.



5.1.3 TEST PROCEDURES

- a. The EUT was placed 0.4 meters from the conducting wall of the shielded room with EUT being connected to the power mains through a line impedance stabilization network (LISN). Other support units were connected to the power mains through another LISN. The two LISNs provide 50 ohm/ 50uH of coupling impedance for the measuring instrument.
- b. Both lines of the power mains connected to the EUT were checked for maximum conducted interference.
- c. The frequency range from 150kHz to 30MHz was searched. Emission levels under (Limit - 20dB) was not recorded.

5.1.4 DEVIATION FROM TEST STANDARD

No deviation

5.1.5 TEST SETUP

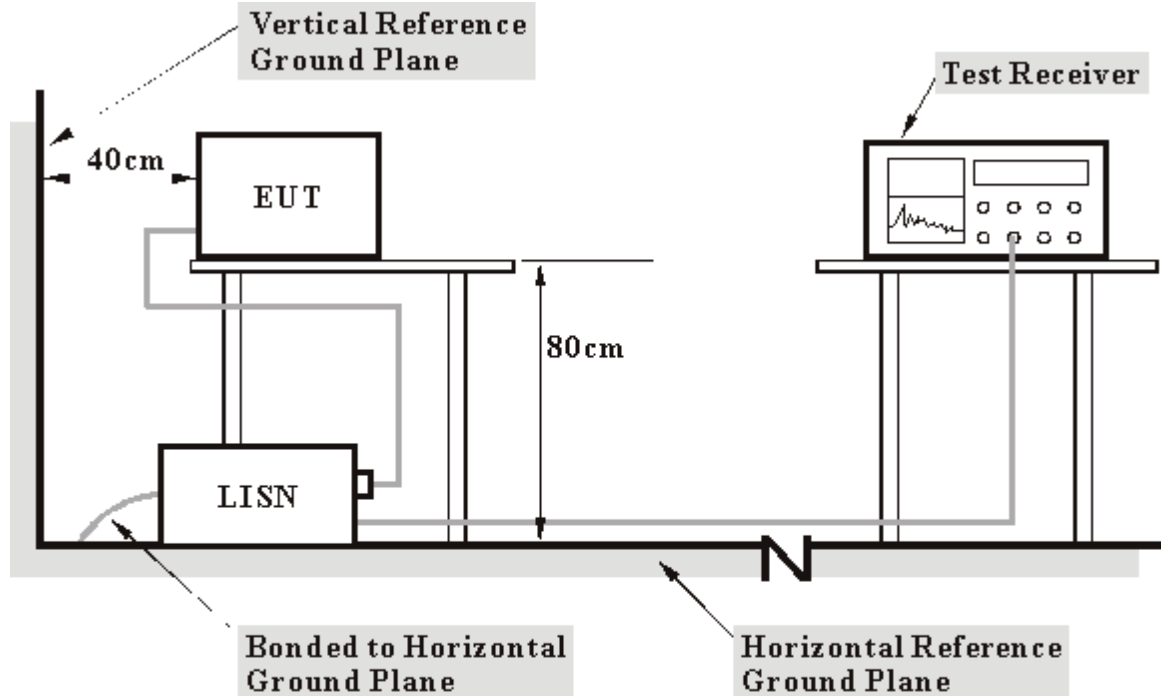

- Note:**
1. Support units were connected to second LISN.
 2. Both of LISNs (AMN) 80 cm from EUT and at the least 80 cm from other units and other metal planes support units.

For the actual test configuration, please refer to the related item – Photographs of the Test Configuration.

5.1.6 EUT OPERATING CONDITIONS

Same as 4.1.6



5.1.7 TEST RESULTS

EUT	MiniPCI 802.11a/b/g Wireless LAN Card	MODEL	Q802MIAG
		6dB BANDWIDTH	9 kHz
INPUT POWER (SYSTEM)	120Vac, 60 Hz	PHASE	Line (L)
ENVIRONMENTAL CONDITIONS	25deg. C, 65%RH, 991hPa	TESTED BY: Match Tsui	

No	Freq. [MHz]	Corr. Factor (dB)	Reading Value [dB (uV)]		Emission Level [dB (uV)]		Limit [dB (uV)]		Margin (dB)	
			Q.P.	AV.	Q.P.	AV.	Q.P.	AV.	Q.P.	AV.
			1	0.189	0.10	41.35	-	41.45	-	64.08
2	0.267	0.10	30.94	-	31.04	-	61.20	51.20	-30.16	-
3	1.469	0.25	31.08	-	31.33	-	56.00	46.00	-24.67	-
4	2.035	0.26	28.98	-	29.24	-	56.00	46.00	-26.76	-
5	10.770	0.56	34.73	-	35.29	-	60.00	50.00	-24.71	-
6	15.801	0.74	29.20	-	29.94	-	60.00	50.00	-30.06	-

- REMARKS:**
1. Q.P. and AV. are abbreviations of quasi-peak and average individually.
 2. "-": The Quasi-peak reading value also meets average limit and measurement with the average detector is unnecessary.
 3. The emission levels of other frequencies were very low against the limit.
 4. Margin value = Emission level - Limit value
 5. Correction factor = Insertion loss + Cable loss
 6. Emission Level = Correction Factor + Reading Value.

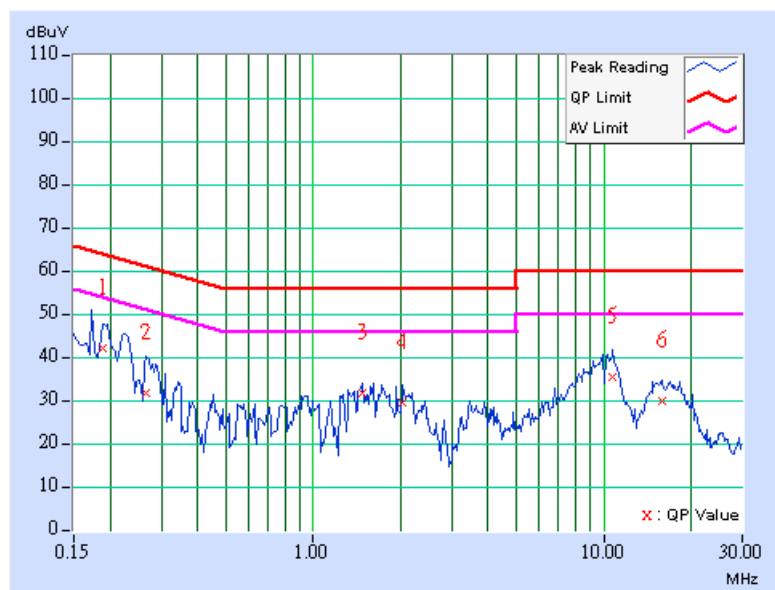



EUT	MiniPCI 802.11a/b/g Wireless LAN Card	MODEL	Q802MIAG
		6dB BANDWIDTH	9 kHz
INPUT POWER (SYSTEM)	120Vac, 60 Hz	PHASE	Neutral (N)
ENVIRONMENTAL CONDITIONS	25deg. C, 65%RH, 991hPa	TESTED BY: Match Tsui	

No	Freq. [MHz]	Corr. Factor (dB)	Reading Value [dB (uV)]		Emission Level [dB (uV)]		Limit [dB (uV)]		Margin (dB)	
			Q.P.	AV.	Q.P.	AV.	Q.P.	AV.	Q.P.	AV.
	1	0.177	0.10	40.19	-	40.29	-	64.61	54.61	-24.32
2	0.224	0.10	43.37	-	43.47	-	62.66	52.66	-19.19	-
3	1.273	0.24	29.05	-	29.29	-	56.00	46.00	-26.71	-
4	1.668	0.25	31.69	-	31.94	-	56.00	46.00	-24.06	-
5	10.957	0.50	33.90	-	34.40	-	60.00	50.00	-25.60	-
6	15.301	0.57	28.71	-	29.28	-	60.00	50.00	-30.72	-

- REMARKS:**
1. Q.P. and AV. are abbreviations of quasi-peak and average individually.
 2. "-": The Quasi-peak reading value also meets average limit and measurement with the average detector is unnecessary.
 3. The emission levels of other frequencies were very low against the limit.
 4. Margin value = Emission level - Limit value
 5. Correction factor = Insertion loss + Cable loss
 6. Emission Level = Correction Factor + Reading Value.

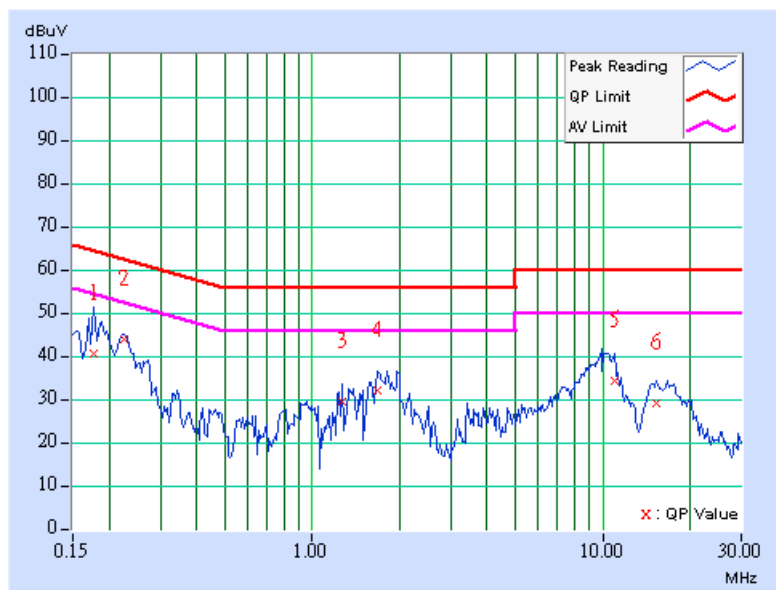



5.2 RADIATED EMISSION MEASUREMENT

5.2.1 LIMITS OF RADIATED EMISSION MEASUREMENT

Emissions radiated outside of the specified bands, shall be according to the general radiated limits in 15.209 as following:

Frequencies (MHz)	Field strength (microvolts/meter)	Measurement distance (meters)
0.009-0.490	2400/F(kHz)	300
0.490-1.705	24000/F(kHz)	30
1.705-30.0	30	30
30-88	100	3
88-216	150	3
216-960	200	3
Above 960	500	3

NOTE:

1. The lower limit shall apply at the transition frequencies.
2. Emission level (dBuV/m) = 20 log Emission level (uV/m).
3. As shown in 15.35(b), for frequencies above 1000MHz, the field strength limits are based on average detector, however, the peak field strength of any emission shall not exceed the maximum permitted average limits, specified above by more than 20dB under any condition of modulation.



5.2.2 LIMITS OF UNWANTED EMISSION OUT OF THE RESTRICTED BANDS

Frequencies (MHz)	EIRP Limit (dBm)	Equivalent Field Strength at 3m (dBμV/m) *note 3
5150~5250	-27	68.3
5250~5350	-27	68.3
5725~5825	-27 *note 1	68.3
	-17 *note 2	78.3

NOTE:

1. For frequencies 10MHz or greater above or below the band edge.
2. All emissions within the frequency range from the band edge to 10MHz above or below the band edge.
3. The following formula is used to convert the equipment isotropic radiated power (eirp) to field strength

$$E = \frac{1000000\sqrt{30P}}{3} \mu\text{V/m, where P is the eirp (Watts)}$$



5.2.3 TEST INSTRUMENTS

DESCRIPTION & MANUFACTURER	MODEL NO.	SERIAL NO.	CALIBRATED UNTIL
Test Receiver ROHDE & SCHWARZ	ESIB7	100188	Jan. 13, 2005
Spectrum Analyzer ROHDE & SCHWARZ	FSP40	100039	Dec. 15, 2004
BILOG Antenna SCHWARZBECK	VULB9168	9168-157	Feb. 03, 2005
HORN Antenna SCHWARZBECK	BBHA 9120 D	9120D-407	Feb. 03, 2005
HORN Antenna SCHWARZBECK	BBHA 9170	BBHA 9170241	Feb. 23, 2005
Preamplifier Agilent	8449B	3008A01961	Jan. 22, 2005
Preamplifier Agilent	8447D	2944A10629	Jan. 14, 2005
RF signal cable HUBER+SUHNER	SUCOFLEX 104	218182/4	Mar. 04, 2005
RF signal cable HUBER+SUHNER	SUCOFLEX 104	218194/4	Mar. 04, 2005
Software ADT.	ADT_Radiated_V5.14	NA	NA
Antenna Tower ADT.	AT100	AT93021702	NA
Turn Table ADT.	TT100.	TT93021702	NA
Controller ADT.	SC100.	SC93021702	NA

- NOTE:**
1. The calibration interval of the above test instruments is 12 months and the calibrations are traceable to NML/ROC and NIST/USA.
 2. The test was performed in HwaYa Chamber 1.
 3. The horn antenna and HP preamplifier (model: 8449B) are used only for the measurement of emission frequency above 1GHz if tested.
 4. The IC Site Registration No. is IC4924-2.



5.2.4 TEST PROCEDURES

- a. The EUT was placed on the top of a rotating table 0.8 meters above the ground at a 3 meter semi-anechoic chamber. The table was rotated 360 degrees to determine the position of the highest radiation.
- b. The EUT was set 3 meters away from the interference-receiving antenna, which was mounted on the top of a variable-height antenna tower.
- c. The antenna is a broadband antenna, and its height is varied from one meter to four meters above the ground to determine the maximum value of the field strength. Both horizontal and vertical polarizations of the antenna are set to make the measurement.
- d. For each suspected emission, the EUT was arranged to its worst case and then the antenna was tuned to heights from 1 meter to 4 meters and the rotatable table was turned from 0 degrees to 360 degrees to find the maximum reading.
- e. The test-receiver system was set to Peak Detect Function and Specified Bandwidth with Maximum Hold Mode.
- f. If the emission level of the EUT in peak mode was 10dB lower than the limit specified, then testing could be stopped and the peak values of the EUT would be reported. Otherwise the emissions that did not have 10dB margin would be re-tested one by one using peak, quasi-peak or average method as specified and then reported in a data sheet.

NOTE:

1. The resolution bandwidth and video bandwidth of test receiver/spectrum analyzer is 120kHz for Peak detection (PK) and Quasi-peak detection (QP) at frequency below 1GHz.
2. The resolution bandwidth and video bandwidth of test receiver/spectrum analyzer is 1 MHz for Peak detection at frequency above 1GHz.
3. The resolution bandwidth of test receiver/spectrum analyzer is 1 MHz and the video bandwidth is 10 Hz for Average detection (AV) at frequency above 1GHz.

5.2.5 DEVIATION FROM TEST STANDARD

No deviation

5.2.6 TEST SETUP

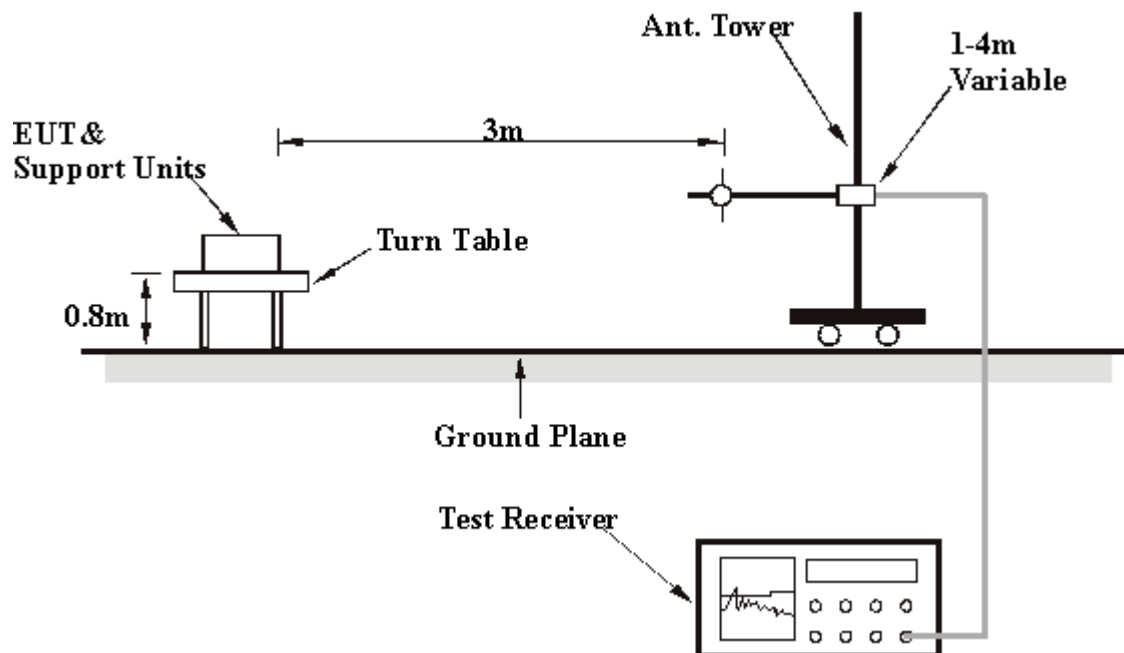

For the actual test configuration, please refer to the related item – Photographs of the Test Configuration.

5.2.7 EUT OPERATING CONDITIONS

Same as 4.1.6



5.2.8 TEST RESULTS

EUT	MiniPCI 802.11a/b/g Wireless LAN Card	MODEL	Q802MIAG
CHANNEL	Channel 8	FREQUENCY RANGE	Below 1000MHz
INPUT POWER (SYSTEM)	120Vac, 60 Hz	DETECTOR FUNCTION	Quasi-Peak
ENVIRONMENTAL CONDITIONS	25deg. C, 60%RH, 991hPa	TESTED BY: Match Tsui	

ANTENNA POLARITY & TEST DISTANCE: HORIZONTAL AT 3 M

No.	Freq. (MHz)	Emission Level (dBuV/m)	Limit (dBuV/m)	Margin (dB)	Antenna Height (m)	Table Angle (Degree)	Raw Value (dBuV)	Correction Factor (dB/m)
1	99.98	38.12 QP	43.50	-5.38	2.50 H	340	27.14	10.98
2	119.42	41.66 QP	43.50	-1.84	1.50 H	325	28.68	12.97
3	133.03	38.28 QP	43.50	-5.22	3.00 H	166	24.34	13.94
4	160.24	35.22 QP	43.50	-8.28	2.50 H	328	20.35	14.87
5	239.94	25.72 QP	46.00	-20.28	1.50 H	91	12.64	13.07
6	331.30	39.69 QP	46.00	-6.31	1.00 H	319	24.47	15.22
7	360.46	43.44 QP	46.00	-2.56	1.00 H	181	27.56	15.88
8	440.16	40.25 QP	46.00	-5.75	2.00 H	1	22.44	17.81
9	479.04	35.71 QP	46.00	-10.29	1.50 H	22	17.26	18.45
10	519.86	38.73 QP	46.00	-7.27	1.50 H	4	19.62	19.11
11	560.68	36.04 QP	46.00	-9.96	1.50 H	16	16.06	19.97
12	599.56	37.98 QP	46.00	-8.02	1.00 H	10	16.98	21.00
13	640.38	35.90 QP	46.00	-10.10	1.00 H	22	14.35	21.55
14	731.74	36.42 QP	46.00	-9.58	1.00 H	310	13.34	23.08
15	799.78	35.55 QP	46.00	-10.45	1.00 H	307	11.73	23.82
16	943.63	42.89 QP	46.00	-3.11	1.50 H	13	17.32	25.57

- REMARKS:**
1. Emission level(dBuV/m)=Raw Value(dBuV) + Correction Factor(dB)
 2. Correction Factor(dB/m) = Antenna Factor (dB/m) + Cable Factor (dB)
 3. The other emission levels were very low against the limit.
 4. Margin value = Emission level – Limit value



EUT	MiniPCI 802.11a/b/g Wireless LAN Card	MODEL	Q802MIAG
CHANNEL	Channel 8	FREQUENCY RANGE	Below 1000MHz
INPUT POWER (SYSTEM)	120Vac, 60 Hz	DETECTOR FUNCTION	Quasi-Peak
ENVIRONMENTAL CONDITIONS	25deg. C, 60%RH, 991hPa	TESTED BY: Match Tsui	

ANTENNA POLARITY & TEST DISTANCE: VERTICAL AT 3 M

No.	Freq. (MHz)	Emission Level (dBuV/m)	Limit (dBuV/m)	Margin (dB)	Antenna Height (m)	Table Angle (Degree)	Raw Value (dBuV)	Correction Factor (dB/m)
1	59.16	31.21 QP	40.00	-8.79	1.50 V	316	17.41	13.79
2	98.04	35.20 QP	43.50	-8.30	1.50 V	277	24.38	10.83
3	119.42	33.00 QP	43.50	-10.50	2.50 V	148	20.03	12.97
4	333.25	32.17 QP	46.00	-13.83	1.50 V	22	16.90	15.26
5	360.46	36.93 QP	46.00	-9.07	2.50 V	142	21.05	15.88
6	383.79	32.90 QP	46.00	-13.10	1.50 V	340	16.51	16.39
7	440.16	31.79 QP	46.00	-14.21	2.00 V	82	13.98	17.81
8	465.43	31.77 QP	46.00	-14.23	1.00 V	328	13.50	18.27
9	479.04	32.63 QP	46.00	-13.37	1.00 V	349	14.17	18.45
10	519.86	31.92 QP	46.00	-14.08	1.00 V	340	12.81	19.11
11	560.68	32.38 QP	46.00	-13.62	1.50 V	271	12.40	19.97
12	599.56	33.32 QP	46.00	-12.68	1.50 V	271	12.33	21.00
13	640.38	29.75 QP	46.00	-16.25	1.00 V	10	8.20	21.55
14	799.78	28.66 QP	46.00	-17.34	1.00 V	328	4.84	23.82
15	906.69	29.64 QP	46.00	-16.36	2.00 V	10	4.46	25.18

- REMARKS:**
1. Emission level(dBuV/m)=Raw Value(dBuV) + Correction Factor(dB)
 2. Correction Factor(dB/m) = Antenna Factor (dB/m) + Cable Factor (dB)
 3. The other emission levels were very low against the limit.
 4. Margin value = Emission level – Limit value



EUT	MiniPCI 802.11a/b/g Wireless LAN Card	MODEL	Q802MIAG
CHANNEL	1	FREQUENCY RANGE	1 ~ 40 GHz
INPUT POWER (SYSTEM)	120Vac, 60Hz	DETECTOR FUNCTION	Peak(PK) Average (AV)
ENVIRONMENTAL CONDITIONS	25deg. C, 60%RH, 991hPa	TESTED BY	Match Tsui

ANTENNA POLARITY & TEST DISTANCE: HORIZONTAL AT 3 M

No.	Freq. (MHz)	Emission Level (dBuV/m)	Limit (dBuV/m)	Margin (dB)	Antenna Height (m)	Table Angle (Degree)	Raw Value (dBuV)	Correction Factor (dB)
1	#5150.00	54.72 PK	74.00	-19.28	1.29 H	199	15.62	39.10
1	#5150.00	44.92 AV	54.00	-9.08	1.29 H	199	5.82	39.10
2	*5180.00	106.51 PK			1.29 H	199	67.34	39.17
2	*5180.00	96.71 AV			1.29 H	199	57.54	39.17
3	10360.00	56.15 PK	68.30	-12.15	1.18 H	242	10.86	45.29

ANTENNA POLARITY & TEST DISTANCE: VERTICAL AT 3 M

No.	Freq. (MHz)	Emission Level (dBuV/m)	Limit (dBuV/m)	Margin (dB)	Antenna Height (m)	Table Angle (Degree)	Raw Value (dBuV)	Correction Factor (dB)
1	#5150.00	57.13 PK	74.00	-16.87	1.12 V	190	18.03	39.10
1	#5150.00	47.32 AV	54.00	-6.68	1.12 V	190	8.22	39.10
2	*5180.00	108.92 PK			1.12 V	190	69.75	39.17
2	*5180.00	99.11 AV			1.12 V	190	59.94	39.17
3	10360.00	59.38 PK	68.30	-8.92	1.00 V	18	14.09	45.29

NOTE:

1. Emission level = Raw value + Correction Factor
2. Correction Factor = Ant. Factor + Cable loss
3. Margin value = Emission level - Limit value
4. The other emission levels were very low against the limit.
5. "*" : Fundamental frequency
6. "#"The radiated frequency falling in the restricted band.



EUT	MiniPCI 802.11a/b/g Wireless LAN Card	MODEL	Q802MIAG
CHANNEL	4	FREQUENCY RANGE	1 ~ 40 GHz
INPUT POWER (SYSTEM)	120Vac, 60Hz	DETECTOR FUNCTION	Peak(PK) Average (AV)
ENVIRONMENTAL CONDITIONS	25deg. C, 60%RH, 991hPa	TESTED BY	Match Tsui

ANTENNA POLARITY & TEST DISTANCE: HORIZONTAL AT 3 M								
No.	Freq. (MHz)	Emission Level (dBuV/m)	Limit (dBuV/m)	Margin (dB)	Antenna Height (m)	Table Angle (Degree)	Raw Value (dBuV)	Correction Factor (dB)
1	*5240.00	106.95 PK			1.26 H	198	67.77	39.18
1	*5240.00	97.13 AV			1.26 H	198	57.95	39.18
2	10480.00	56.31 PK	68.30	-11.99	1.13 H	180	10.22	46.08

ANTENNA POLARITY & TEST DISTANCE: VERTICAL AT 3 M								
No.	Freq. (MHz)	Emission Level (dBuV/m)	Limit (dBuV/m)	Margin (dB)	Antenna Height (m)	Table Angle (Degree)	Raw Value (dBuV)	Correction Factor (dB)
1	*5240.00	107.07 PK			1.17 V	303	67.89	39.18
1	*5240.00	97.56 AV			1.17 V	303	58.38	39.18
2	10480.00	58.42 PK	68.30	-9.88	1.02 V	43	12.33	46.08

NOTE:

1. Emission level = Raw value + Correction Factor
2. Correction Factor = Ant. Factor + Cable loss
3. Margin value = Emission level - Limit value
4. The other emission levels were very low against the limit.
5. "*" : Fundamental frequency
6. "#": The radiated frequency falling in the restricted band.



EUT	MiniPCI 802.11a/b/g Wireless LAN Card	MODEL	Q802MIAG
CHANNEL	5	FREQUENCY RANGE	1 ~ 40 GHz
INPUT POWER (SYSTEM)	120Vac, 60Hz	DETECTOR FUNCTION	Peak(PK) Average (AV)
ENVIRONMENTAL CONDITIONS	25deg. C, 60%RH, 991hPa	TESTED BY	Match Tsui

ANTENNA POLARITY & TEST DISTANCE: HORIZONTAL AT 3 M

No.	Freq. (MHz)	Emission Level (dBuV/m)	Limit (dBuV/m)	Margin (dB)	Antenna Height (m)	Table Angle (Degree)	Raw Value (dBuV)	Correction Factor (dB)
1	*5260.00	106.20 PK			1.15 H	178	67.04	39.16
1	*5260.00	96.59 AV			1.15 H	178	57.43	39.16
2	10520.00	56.91 PK	68.30	-11.39	1.18 H	159	10.76	46.16

ANTENNA POLARITY & TEST DISTANCE: VERTICAL AT 3 M

No.	Freq. (MHz)	Emission Level (dBuV/m)	Limit (dBuV/m)	Margin (dB)	Antenna Height (m)	Table Angle (Degree)	Raw Value (dBuV)	Correction Factor (dB)
1	*5260.00	109.04 PK			1.09 V	190	69.88	39.16
1	*5260.00	99.23 AV			1.09 V	190	60.07	39.16
2	10520.00	59.13 PK	68.30	-9.17	1.08 V	41	12.98	46.16

NOTE:

1. Emission level = Raw value + Correction Factor
2. Correction Factor = Ant. Factor + Cable loss
3. Margin value = Emission level - Limit value
4. The other emission levels were very low against the limit.
5. "*" : Fundamental frequency
6. "#"The radiated frequency falling in the restricted band.



EUT	MiniPCI 802.11a/b/g Wireless LAN Card	MODEL	Q802MIAG
CHANNEL	8	FREQUENCY RANGE	1 ~ 40 GHz
INPUT POWER (SYSTEM)	120Vac, 60Hz	DETECTOR FUNCTION	Peak(PK) Average (AV)
ENVIRONMENTAL CONDITIONS	25deg. C, 60%RH, 991hPa	TESTED BY	Match Tsui

ANTENNA POLARITY & TEST DISTANCE: HORIZONTAL AT 3 M								
No.	Freq. (MHz)	Emission Level (dBuV/m)	Limit (dBuV/m)	Margin (dB)	Antenna Height (m)	Table Angle (Degree)	Raw Value (dBuV)	Antenna Factor (dB)
1	*5320.00	106.07 PK			1.14 H	181	66.92	39.15
1	*5320.00	96.37 AV			1.14 H	181	57.22	39.15
2	#10640.00	56.88 PK	74.00	-17.12	1.14 H	245	10.65	46.23
2	#10640.00	44.96 AV	54.00	-9.04	1.14 H	245	-1.27	46.23

ANTENNA POLARITY & TEST DISTANCE: VERTICAL AT 3 M								
No.	Freq. (MHz)	Emission Level (dBuV/m)	Limit (dBuV/m)	Margin (dB)	Antenna Height (m)	Table Angle (Degree)	Raw Value (dBuV)	Antenna Factor (dB)
1	*5320.00	107.37 PK			1.05 V	301	68.22	39.15
1	*5320.00	97.64 AV			1.05 V	301	58.49	39.15
2	#5350.00	54.71 PK	74.00	-19.29	1.05 V	301	15.51	39.20
2	#5350.00	44.98 AV	54.00	-9.02	1.05 V	301	5.78	39.20
3	#10640.00	62.38 PK	74.00	-11.62	1.04 V	27	16.15	46.23
3	#10640.00	49.56 AV	54.00	-4.44	1.04 V	27	3.33	46.23

NOTE:

1. Emission level = Raw value + Correction Factor
2. Correction Factor = Ant. Factor + Cable loss
3. Margin value = Emission level - Limit value
4. The other emission levels were very low against the limit.
5. "*" : Fundamental frequency
6. "#" The radiated frequency falling in the restricted band.



EUT	MiniPCI 802.11a/b/g Wireless LAN Card	MODEL	Q802MIAG
CHANNEL	9	FREQUENCY RANGE	1 ~ 40 GHz
INPUT POWER (SYSTEM)	120Vac, 60Hz	DETECTOR FUNCTION	Peak(PK) Average (AV)
ENVIRONMENTAL CONDITIONS	25deg. C, 60%RH, 991hPa	TESTED BY	Match Tsui

ANTENNA POLARITY & TEST DISTANCE: HORIZONTAL AT 3 M								
No.	Freq. (MHz)	Emission Level (dBuV/m)	Limit (dBuV/m)	Margin (dB)	Antenna Height (m)	Table Angle (Degree)	Raw Value (dBuV)	Correction Factor (dB/m)
1	5715.00	67.29 PK	68.30	-1.01	1.13 H	224	26.50	40.79
2	5725.00	70.02 PK	78.30	-8.28	1.13 H	224	29.19	40.83
3	*5745.00	106.66 PK			1.13 H	224	65.76	40.90
3	*5745.00	96.90 AV			1.13 H	224	56.00	40.90

ANTENNA POLARITY & TEST DISTANCE: VERTICAL AT 3 M								
No.	Freq. (MHz)	Emission Level (dBuV/m)	Limit (dBuV/m)	Margin (dB)	Antenna Height (m)	Table Angle (Degree)	Raw Value (dBuV)	Correction Factor (dB/m)
1	5715.00	67.19 PK	68.30	-1.11	1.11 V	185	26.40	40.79
2	5725.00	73.23 PK	78.30	-5.07	1.11 V	185	32.40	40.83
3	*5745.00	110.06 PK			1.11 V	185	69.16	40.90
3	*5745.00	100.19 AV			1.11 V	185	59.29	40.90

NOTE:

1. Emission level(dBuV/m)=Raw Value(dBuV) + Correction Factor(dB).
2. Correction Factor(dB/m) = Antenna Factor (dB/m) + Cable Factor (dB).
3. The other emission levels were very low against the limit.
4. Margin value = Emission level – Limit value.
5. “ * “ : Fundamental frequency.
6. “#”The radiated frequency falling in the restricted band.



EUT	MiniPCI 802.11a/b/g Wireless LAN Card	MODEL	Q802MIAG
CHANNEL	12	FREQUENCY RANGE	1 ~ 40 GHz
INPUT POWER (SYSTEM)	120Vac, 60Hz	DETECTOR FUNCTION	Peak(PK) Average (AV)
ENVIRONMENTAL CONDITIONS	25deg. C, 60%RH, 991hPa	TESTED BY	Match Tsui

ANTENNA POLARITY & TEST DISTANCE: HORIZONTAL AT 3 M

No.	Freq. (MHz)	Emission Level (dBuV/m)	Limit (dBuV/m)	Margin (dB)	Antenna Height (m)	Table Angle (Degree)	Raw Value (dBuV)	Correction Factor (dB/m)
1	*5805.00	107.11 PK			1.14 H	146	66.04	41.07
1	*5805.00	97.31 AV			1.14 H	146	56.24	41.07
2	5825.00	71.55 PK	78.30	-6.75	1.14 H	146	30.60	40.95
3	5835.00	67.20 PK	68.30	-1.10	1.14 H	146	26.32	40.88

ANTENNA POLARITY & TEST DISTANCE: VERTICAL AT 3 M

No.	Freq. (MHz)	Emission Level (dBuV/m)	Limit (dBuV/m)	Margin (dB)	Antenna Height (m)	Table Angle (Degree)	Raw Value (dBuV)	Correction Factor (dB/m)
1	*5805.00	108.57 PK			1.14 V	304	67.50	41.07
1	*5805.00	98.87 AV			1.14 V	304	57.80	41.07
2	5825.00	71.87 PK	78.30	-6.43	1.14 V	304	30.92	40.95
3	5835.00	67.18 PK	68.30	-1.12	1.14 V	304	26.30	40.88

NOTE:

1. Emission level(dBuV/m)=Raw Value(dBuV) + Correction Factor(dB).
2. Correction Factor(dB/m) = Antenna Factor (dB/m) + Cable Factor (dB).
3. The other emission levels were very low against the limit.
4. Margin value = Emission level – Limit value.
5. “ * “ : Fundamental frequency.
6. “#”The radiated frequency falling in the restricted band.



5.3 PEAK TRANSMIT POWER MEASUREMENT

5.3.1 LIMITS OF PEAK TRANSMIT POWER MEASUREMENT

Frequency Band	Limit
5.15 – 5.25 GHz	The lesser of 50mW (17dBm) or 4dBm + 10logB
5.25 – 5.35 GHz	The lesser of 250mW (24dBm) or 11dBm + 10logB
5.725 – 5.825 GHz	The lesser of 1W (30dBm) or 17dBm + 10logB

Note: Where B is the 26dB emission bandwidth in MHz.

5.3.2 TEST INSTRUMENTS

Description & Manufacturer	Model No.	Serial No.	Calibrated Until
SPECTRUM ANALYZER	FSEK30	100049	Aug. 12, 2005

NOTE:

The calibration interval of the above test instruments is 12 months and the calibrations are traceable to NML/ROC and NIST/USA.

5.3.3 TEST PROCEDURE

1. The transmitter output was connected to the spectrum analyzer.
2. Set span to encompass the entire emission bandwidth of the signal.
3. Set RBW to 1MHz, VBW to 300kHz.
4. Using the spectrum analyzer's channel power measurement function to measure the output power.

5.3.4 DEVIATION FROM TEST STANDARD

No deviation

5.3.5 TEST SETUP

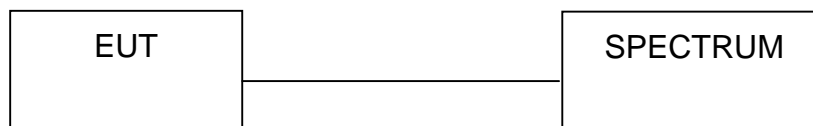

5.3.6 EUT OPERATING CONDITIONS

The software provided by client to enable the EUT under transmission condition continuously at specific channel frequencies individually.



5.3.7 TEST RESULTS

EUT	MiniPCI 802.11a/b/g Wireless LAN Card	MODEL	Q802MIAG
ENVIRONMENTAL CONDITIONS	24deg. C, 64%RH, 991hPa	INPUT POWER (SYSTEM)	120Vac, 60 Hz
TESTED BY	Leo Hung		

CHANNEL	CHANNEL FREQUENCY (MHz)	PEAK POWER OUTPUT (mW)	PEAK POWER OUTPUT (dBm)	PEAK POWER LIMIT (dBm)	26dBc Occupied Bandwidth (MHz)	PASS/FAIL
1	5180	32.063	15.06	17.00	21.67	PASS
4	5240	32.211	15.08	17.00	21.81	PASS
5	5260	32.137	15.07	24.00	21.95	PASS
8	5320	32.359	15.10	24.00	24.19	PASS
9	5745	31.696	15.01	30.00	22.30	PASS
12	5805	31.769	15.02	30.00	21.88	PASS

NOTE: The 26dBc Occupied Bandwidth plot, please refer to the following pages.



CH 4

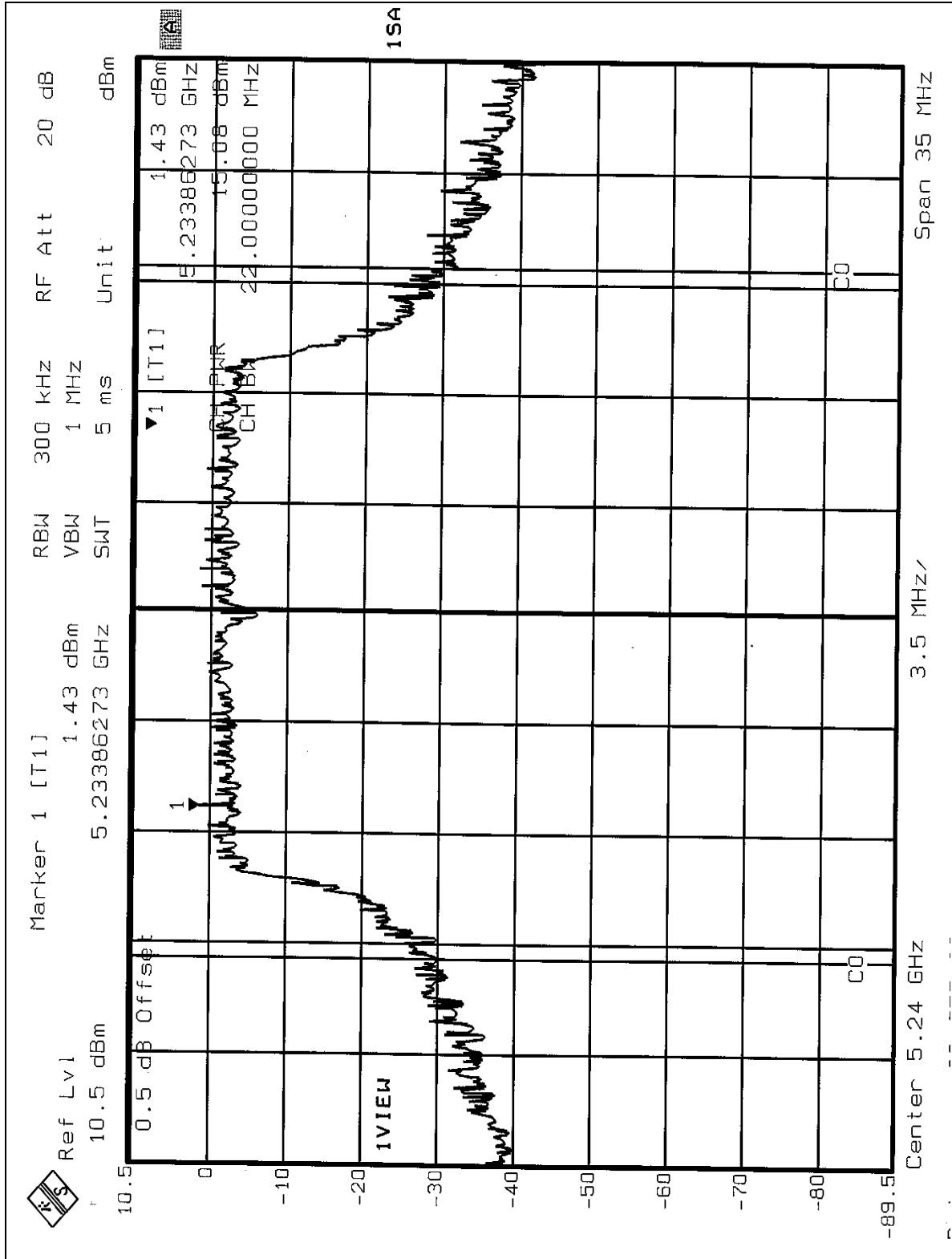



CH 5

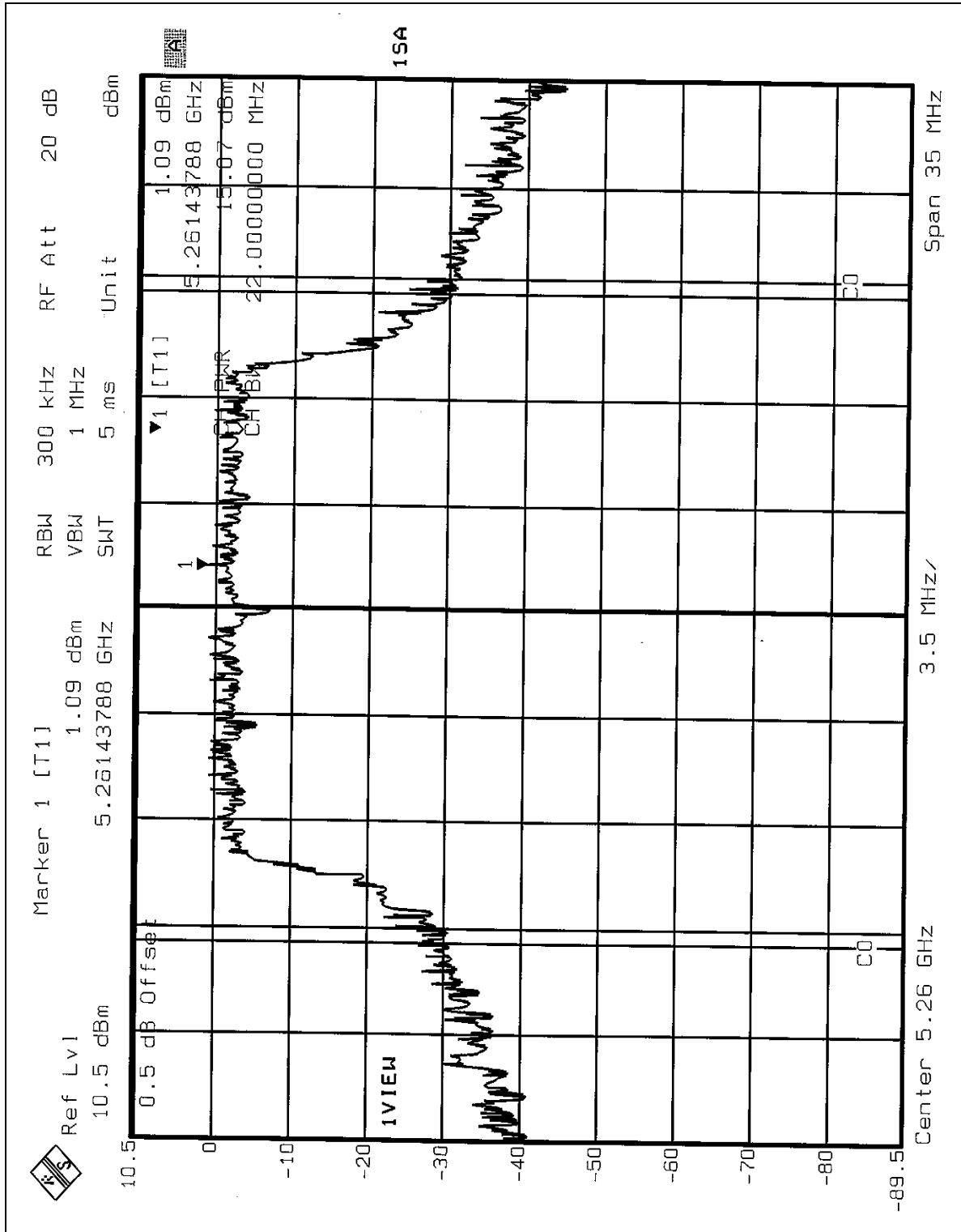



CH 9

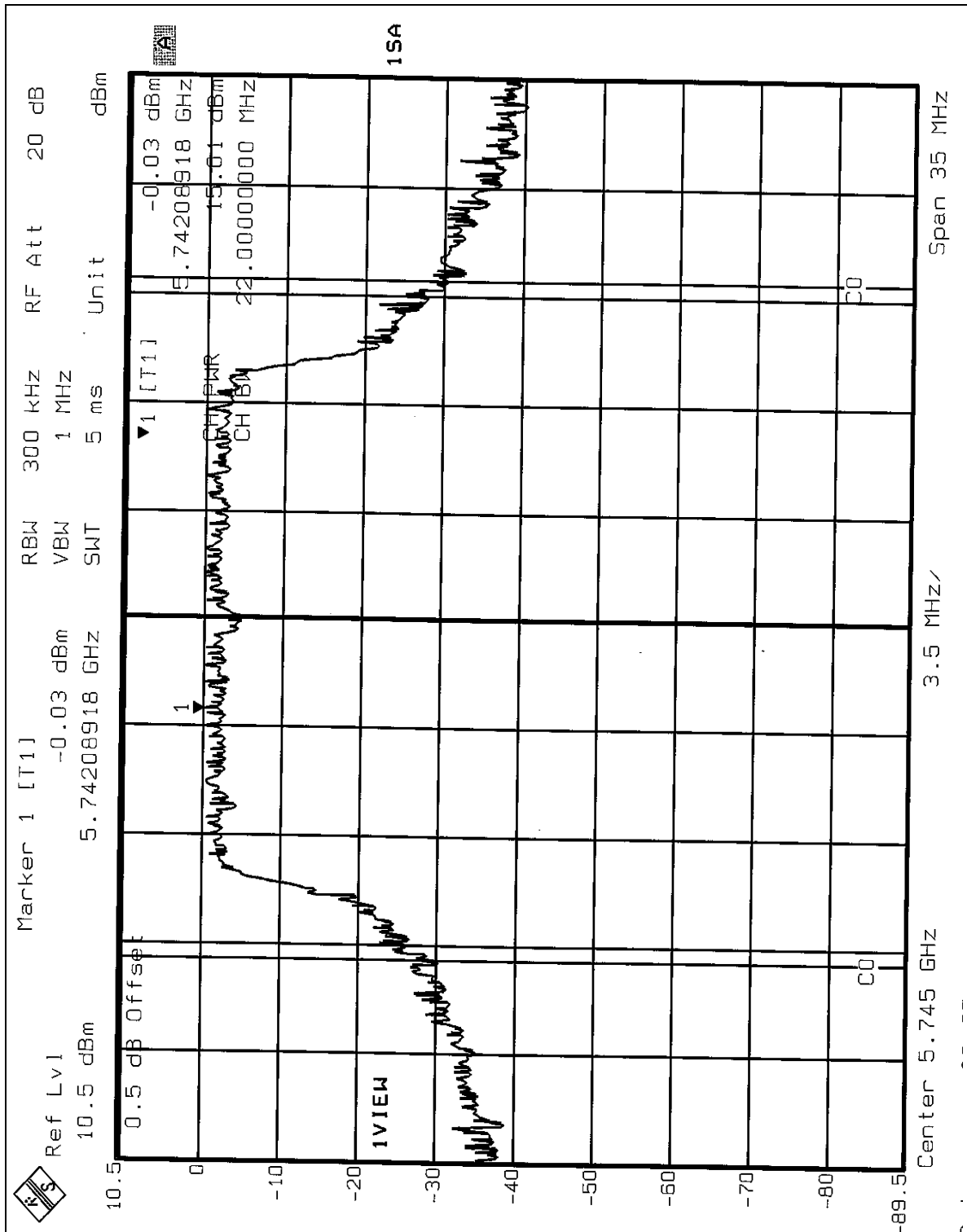



CH 12

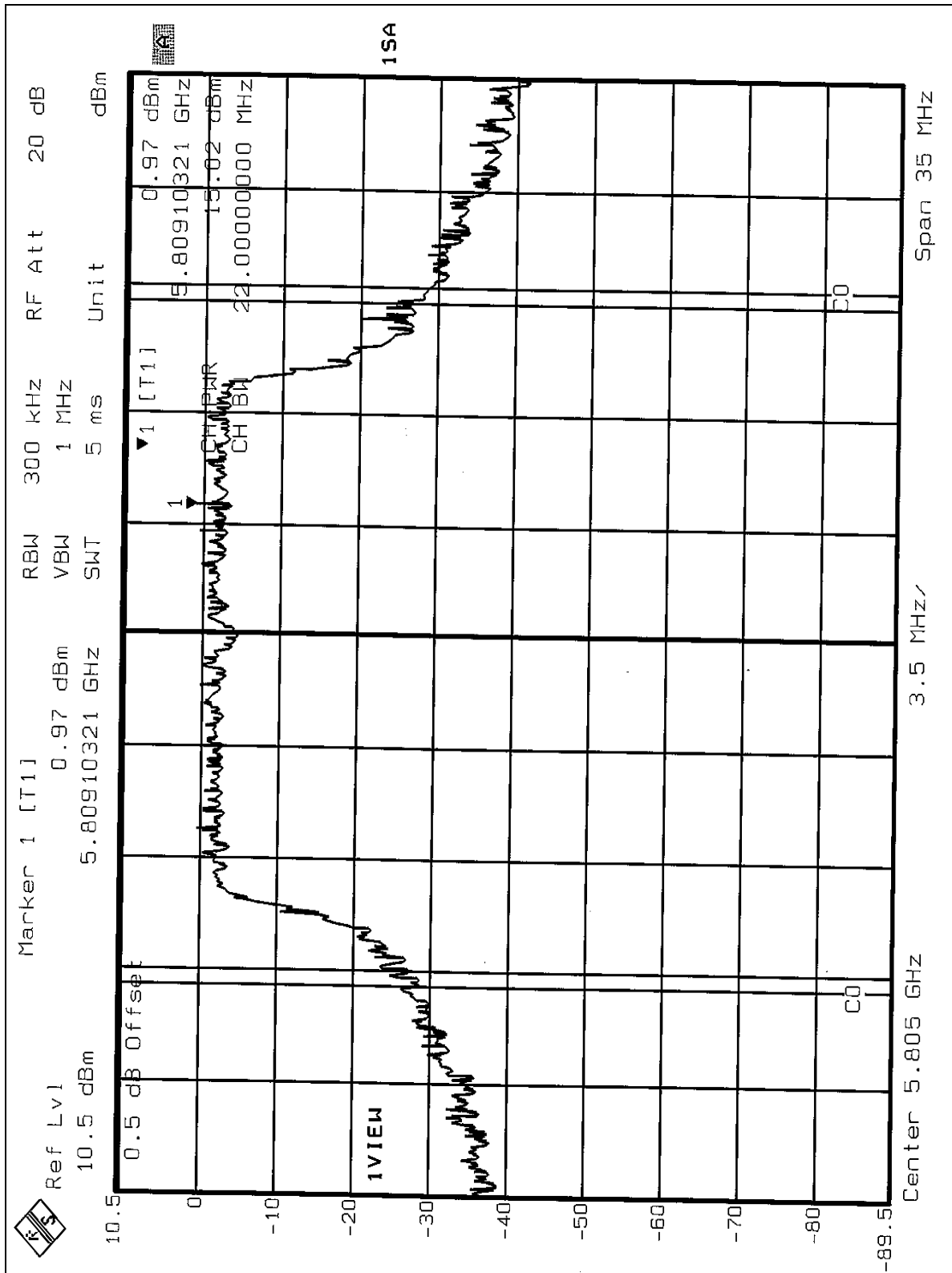



CH 4

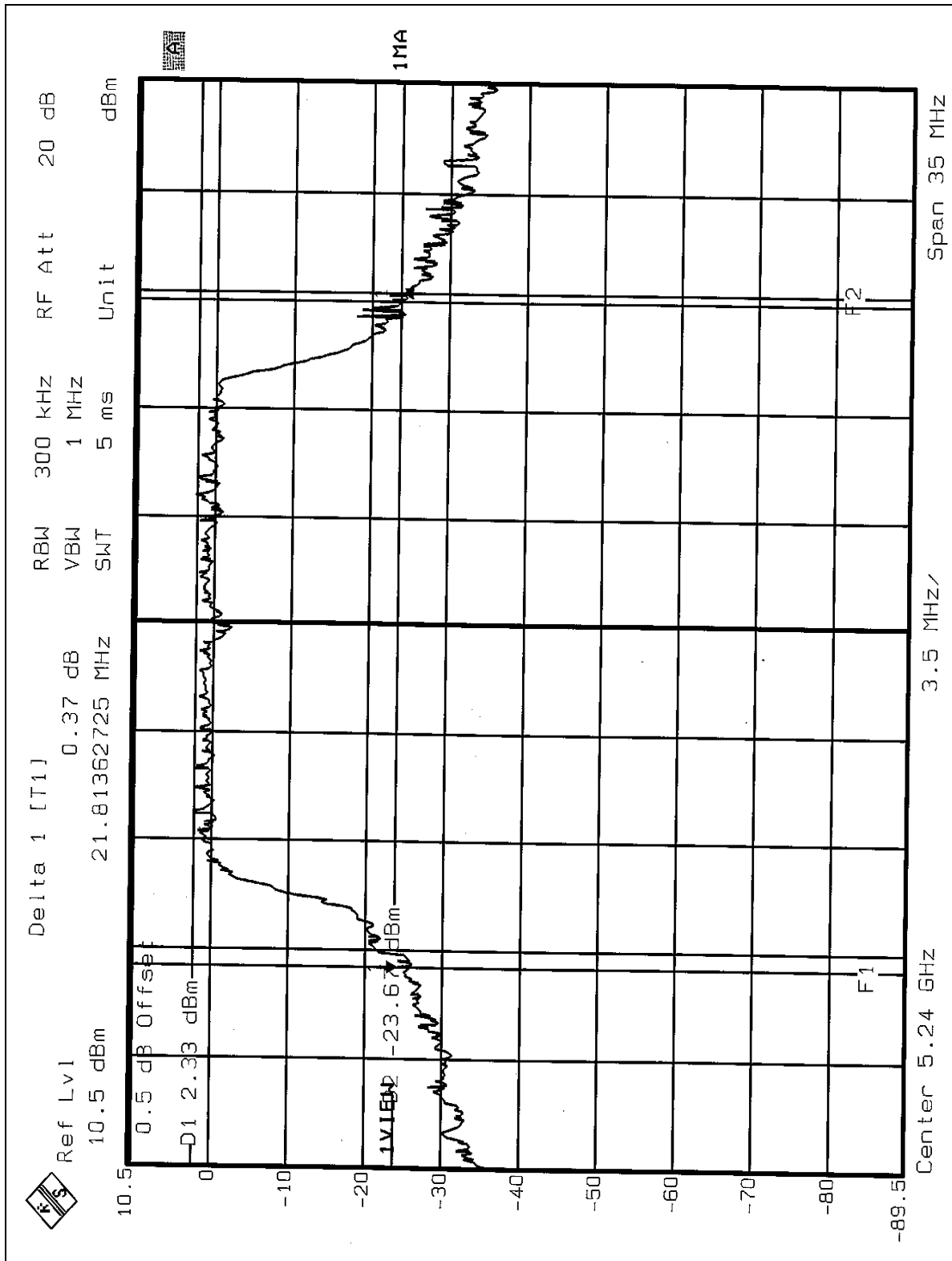



CH 5

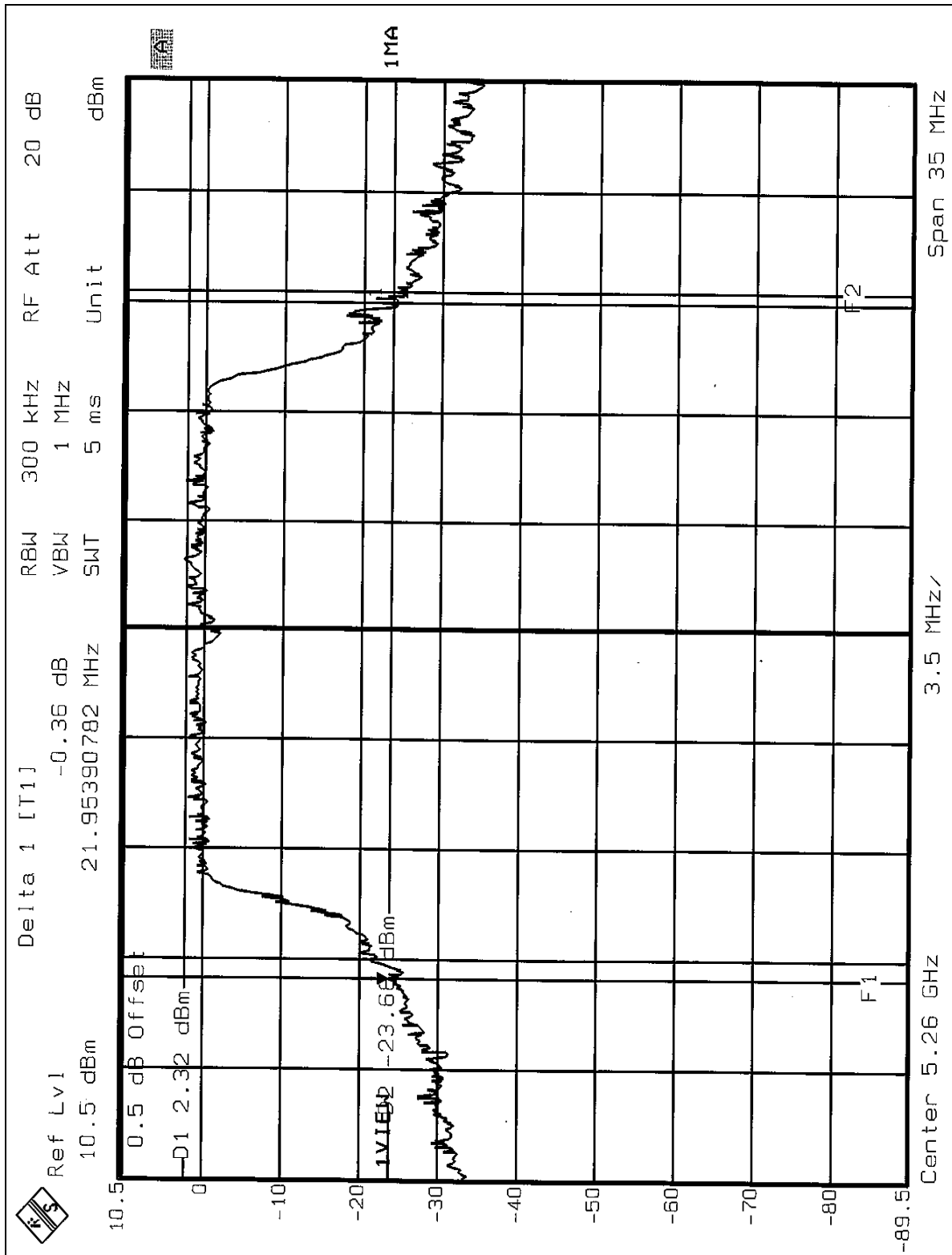



CH 8

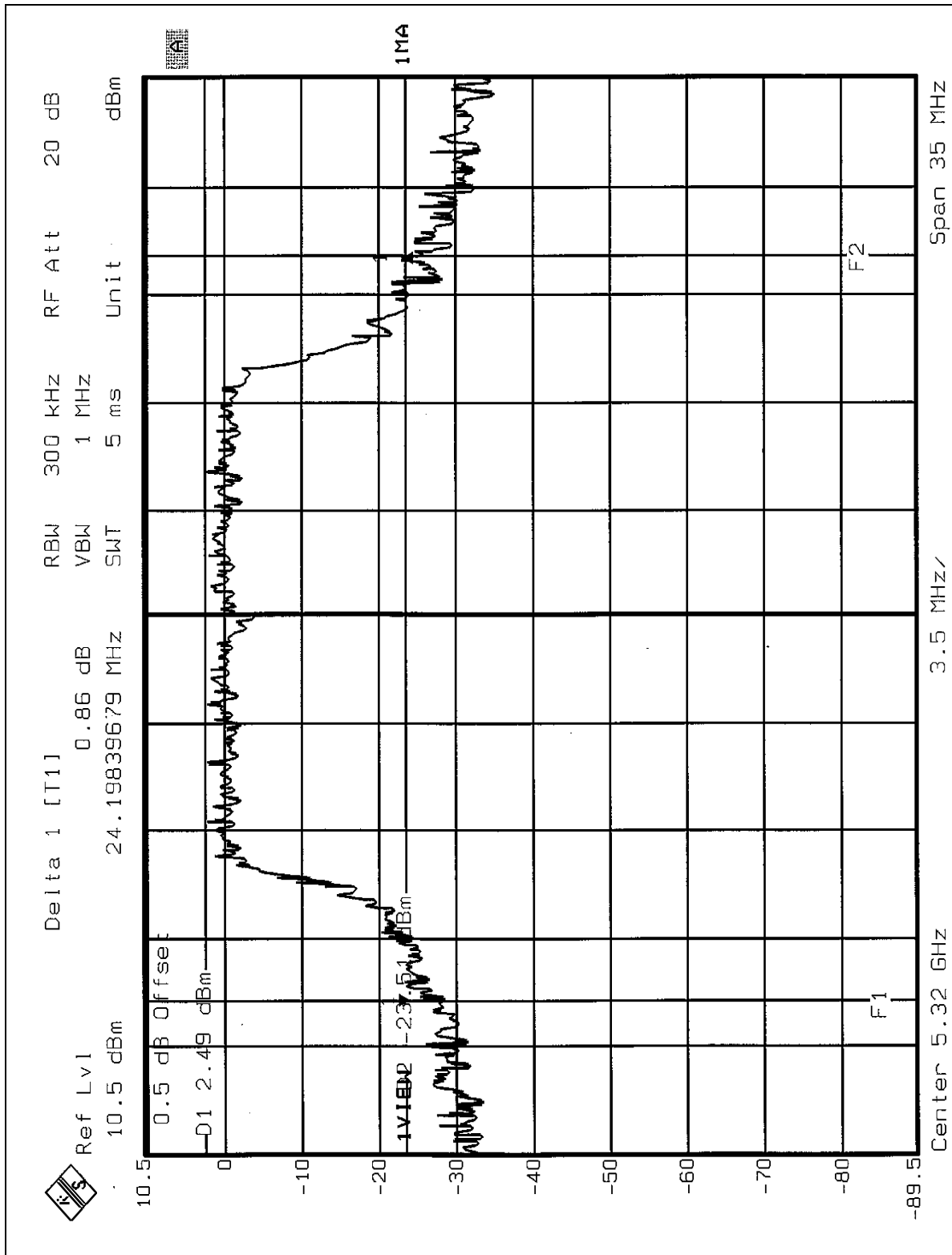



CH 9

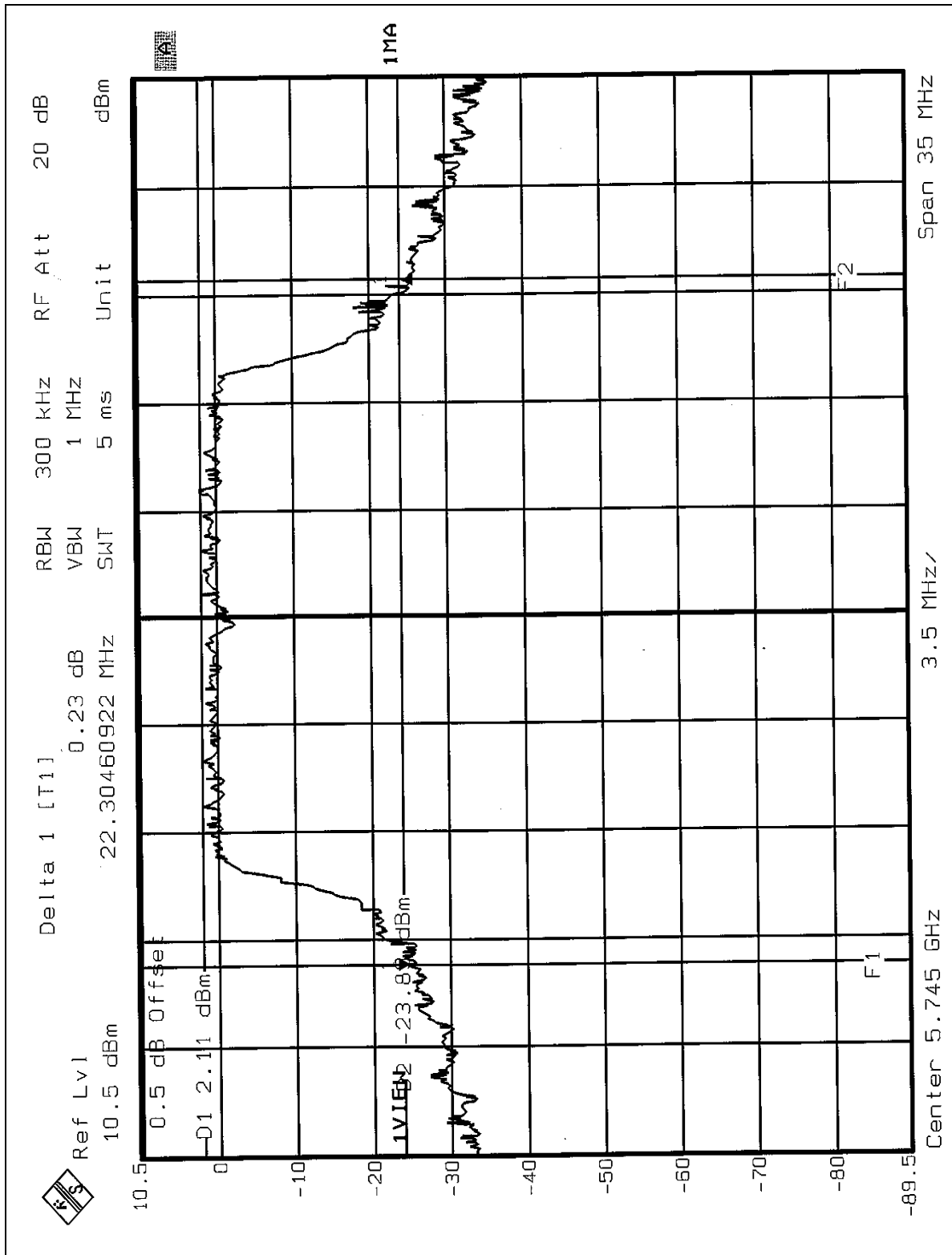



CH 12

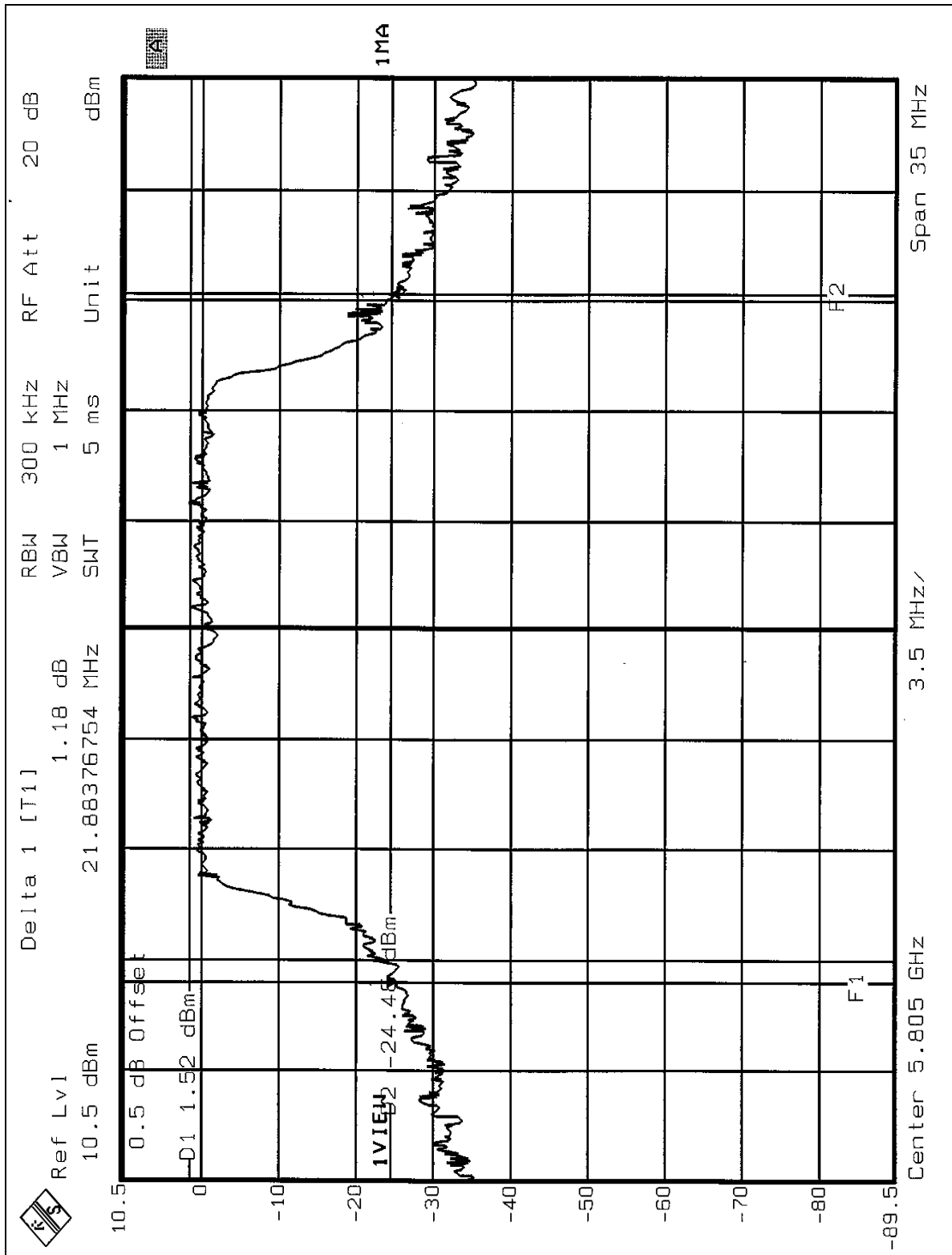



5.4 PEAK POWER EXCURSION MEASUREMENT

5.4.1 LIMITS OF PEAK POWER EXCURSION MEASUREMENT

Frequency Band	Limit
5.15 – 5.25 GHz	13dB
5.25 – 5.35 GHz	13dB
5.725 – 5.825 GHz	13dB

5.4.2 TEST INSTRUMENTS

Description & Manufacturer	Model No.	Serial No.	Calibrated Until
ROHDE&SCHWARZ SPECTRUM ANALYZER	FSEK30	100049	Aug. 12, 2005

NOTE:

The calibration interval of the above test instruments is 12 months and the calibrations are traceable to NML/ROC and NIST/USA.



5.4.3 TEST PROCEDURE

1. The transmitter output was connected to the spectrum analyzer.
2. Set the spectrum bandwidth span to view the entire spectrum.
3. Using peak detector and Max-hold function for Trace 1 (RB=1MHz, VB=3MHz) and 2 (RB=1MHz, VB=300KHz).
4. The largest difference between Trace 1 and Trace 2 in any 1MHz band on any frequency was recorded.

5.4.4 DEVIATION FROM TEST STANDARD

No deviation

5.4.5 TEST SETUP

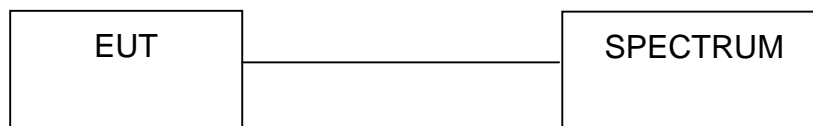

5.4.6 EUT OPERATING CONDITIONS

The software provided by client to enable the EUT under transmission condition continuously at specific channel frequencies individually.



5.4.7 TEST RESULTS

EUT	MiniPCI 802.11a/b/g Wireless LAN Card	MODEL	Q802MIAG
ENVIRONMENTAL CONDITIONS	24deg. C, 64%RH, 991hPa	INPUT POWER (SYSTEM)	120Vac, 60 Hz
TESTED BY	Leo Hung		

CHANNEL	CHANNEL FREQUENCY (MHz)	PEAK POWER EXCURSION (dB)	PEAK to AVERAGE EXCURSION LIMIT (dB)	PASS/FAIL
1	5180	5.96	13	PASS
4	5240	5.54	13	PASS
5	5260	5.23	13	PASS
8	5320	5.52	13	PASS
9	5745	6.01	13	PASS
12	5805	6.79	13	PASS



CH 1

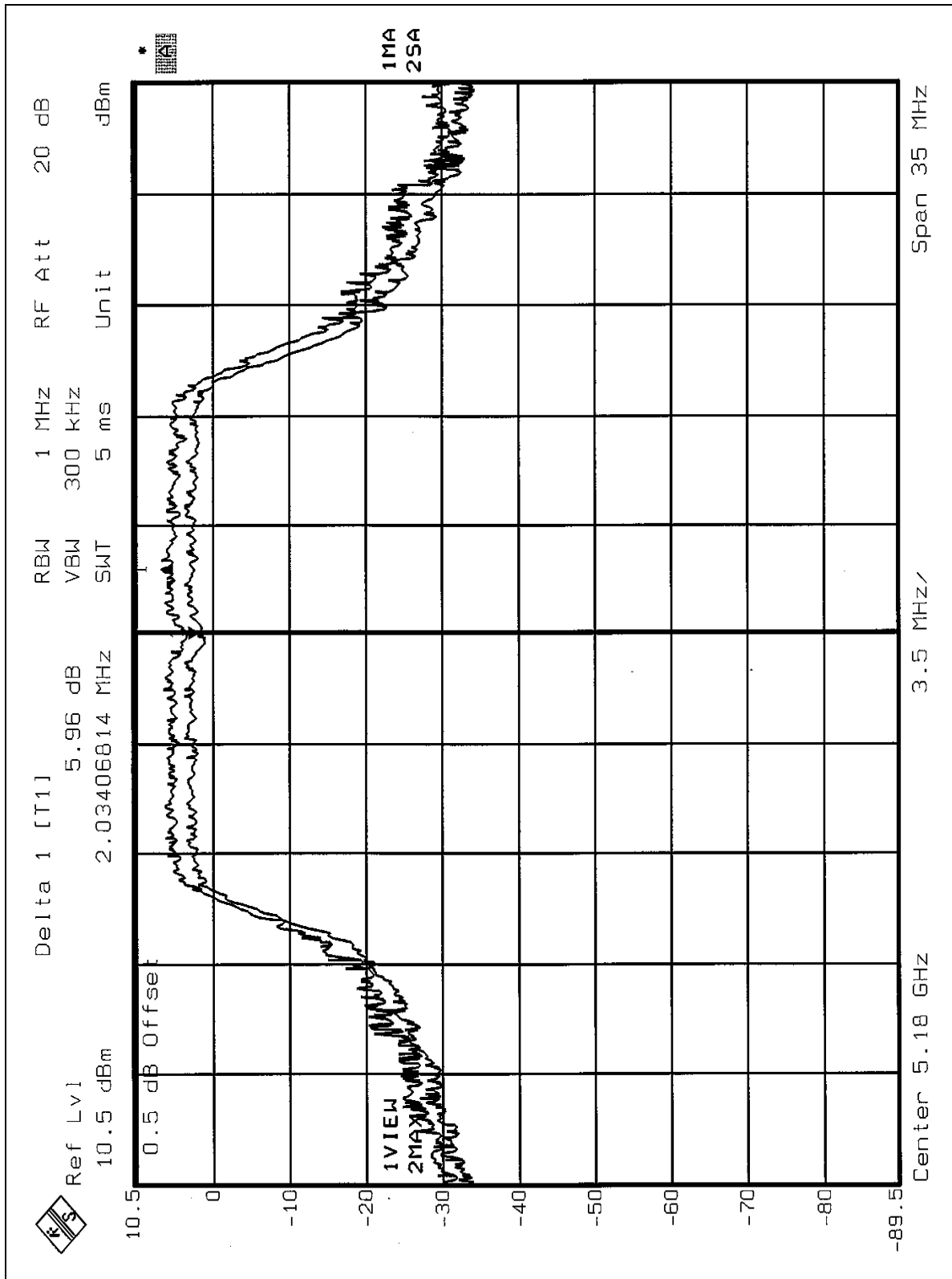



CH 4

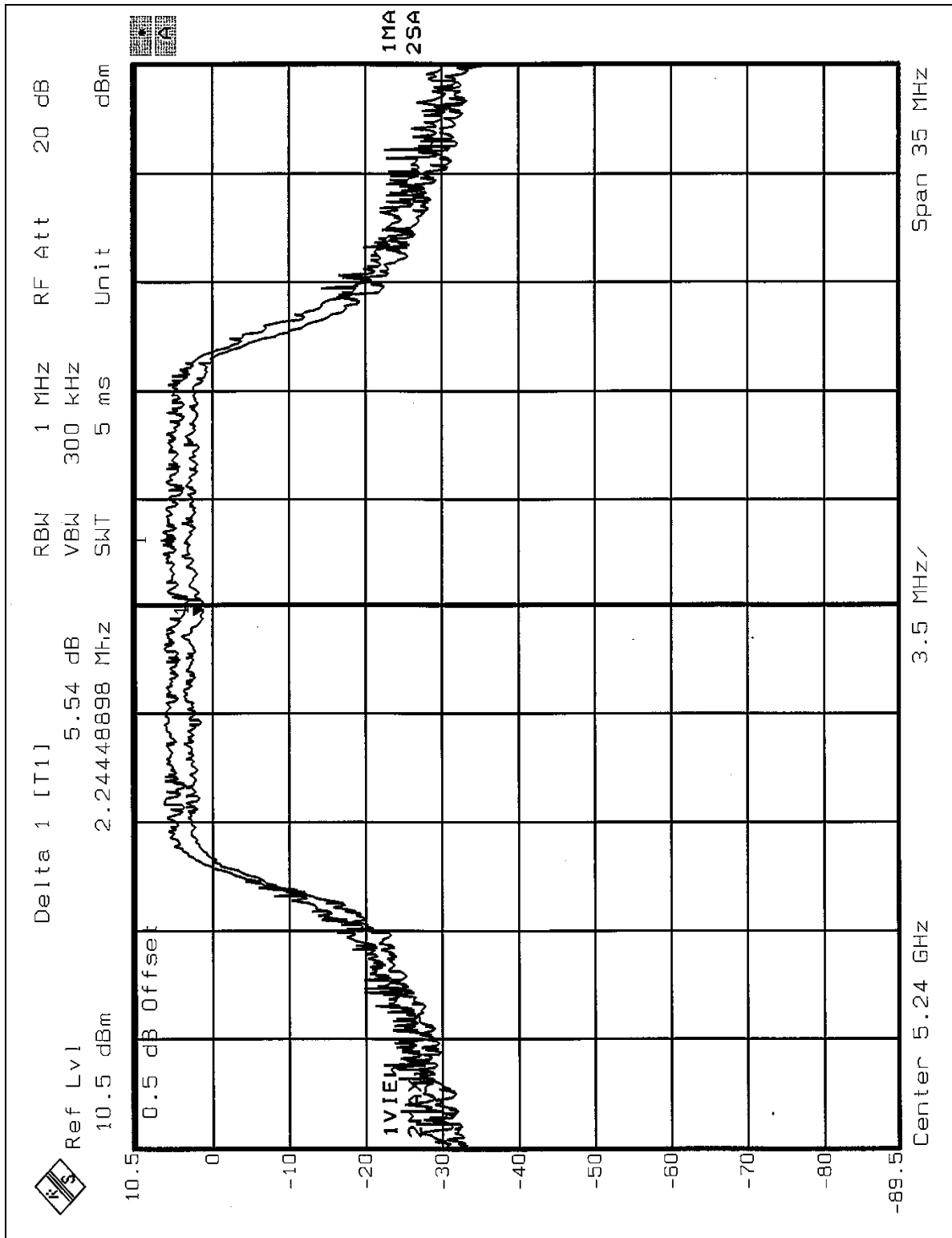



CH 5

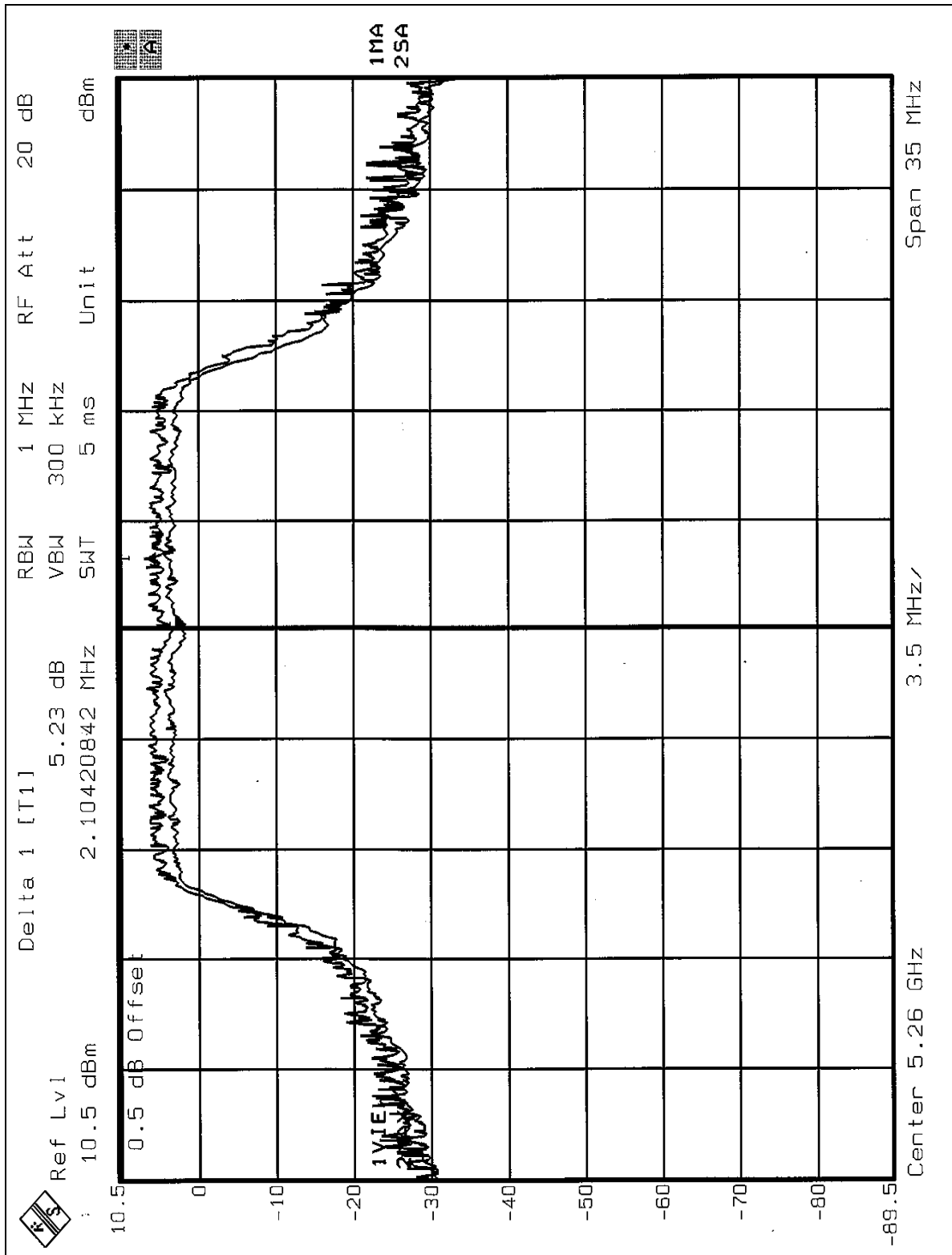



CH 8

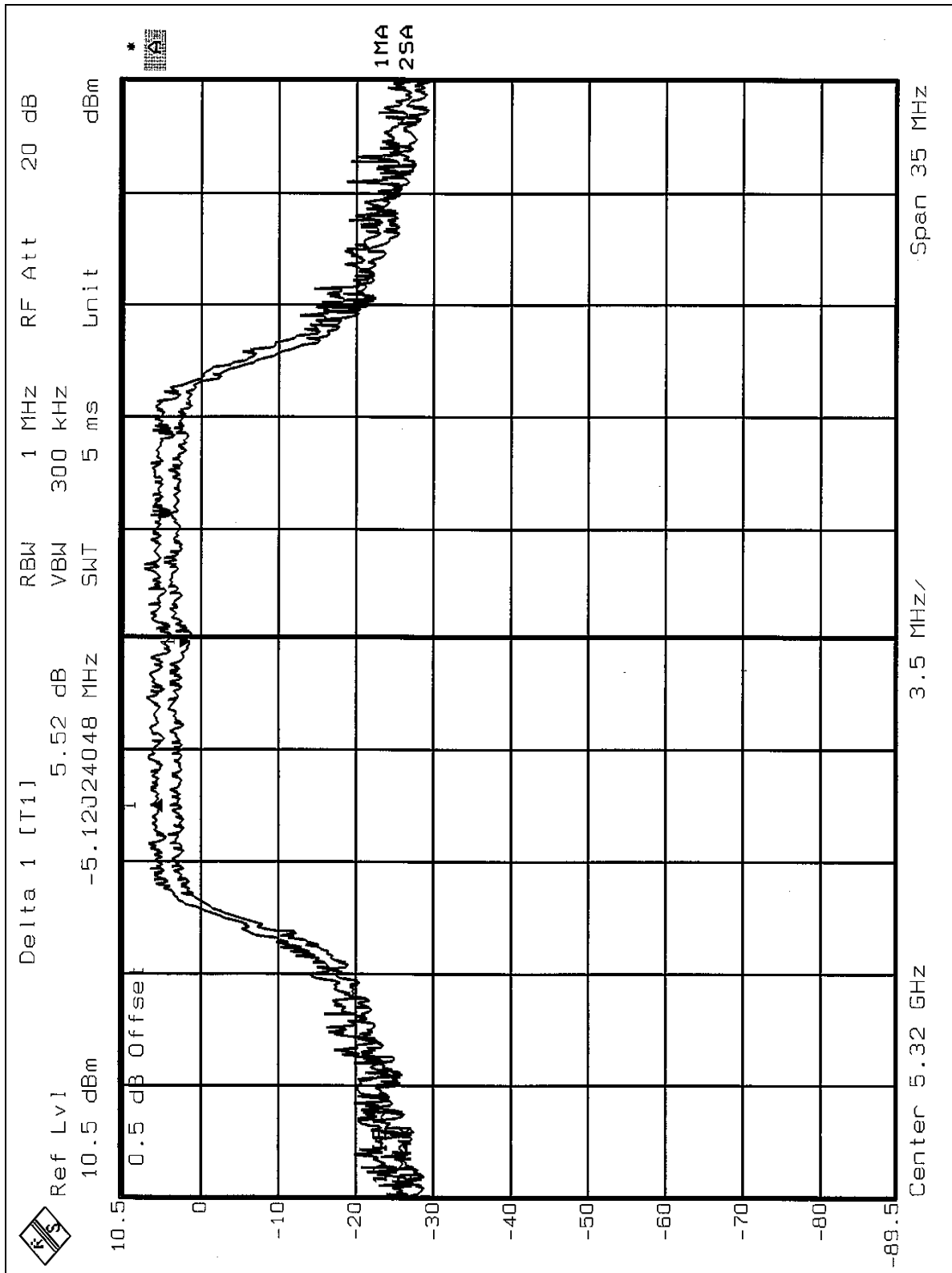



CH 9

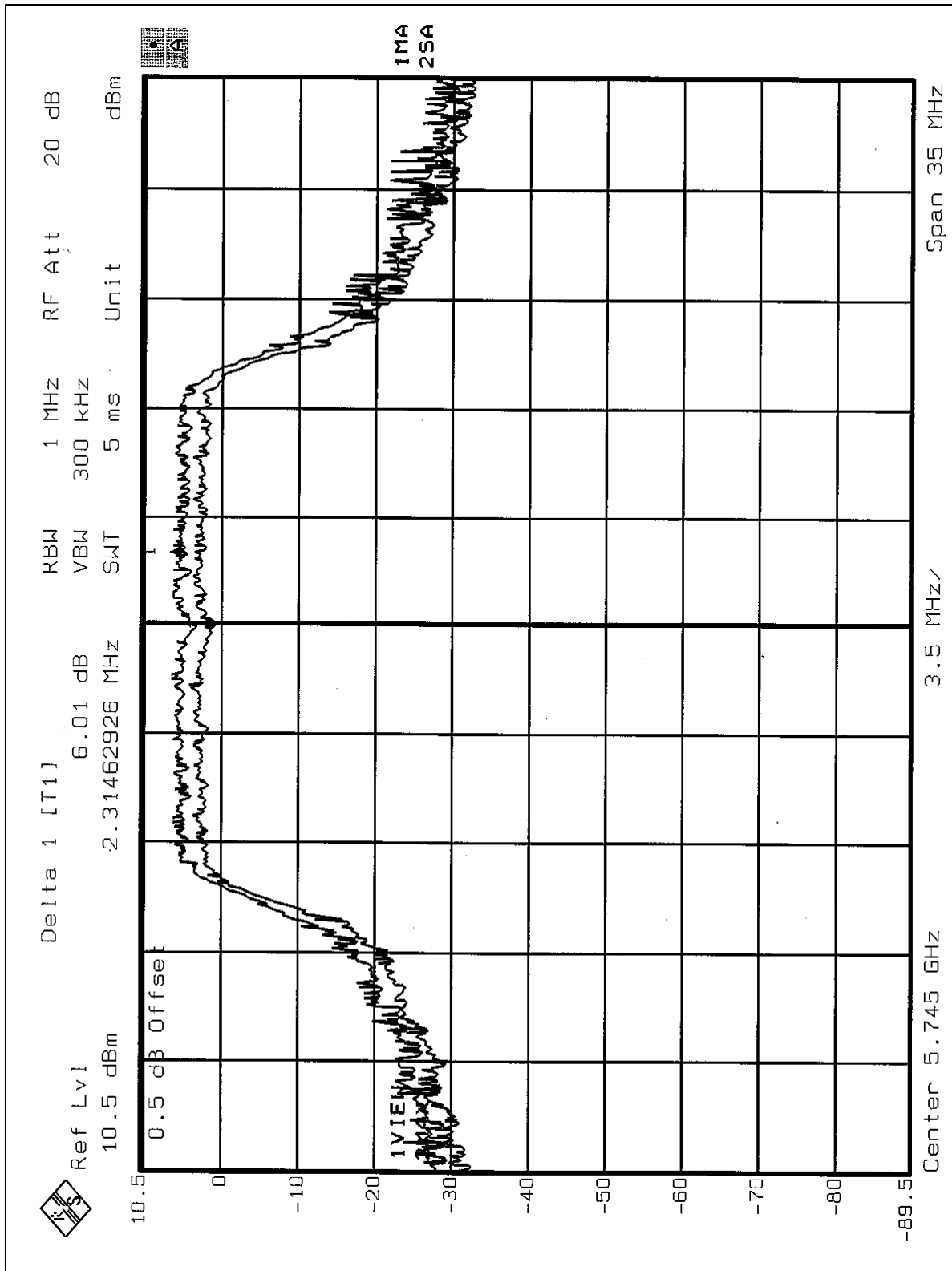



CH 12

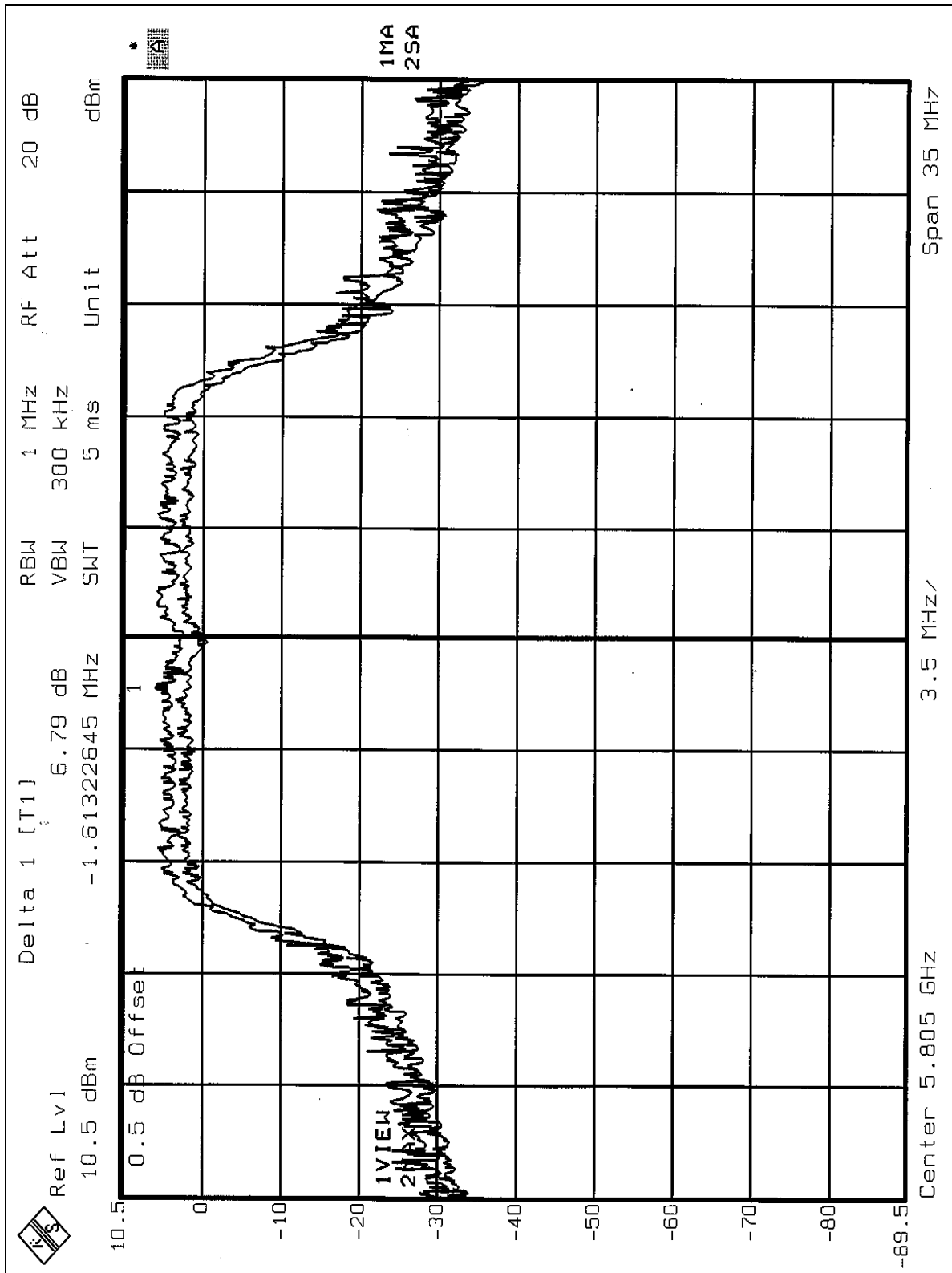



5.5 PEAK POWER SPECTRAL DENSITY MEASUREMENT

5.5.1 LIMITS OF PEAK POWER SPECTRAL DENSITY MEASUREMENT

Frequency Band	Limit
5.15 – 5.25 GHz	4dBm
5.25 – 5.35 GHz	11dBm
5.725 – 5.825 GHz	17dBm

5.5.2 TEST INSTRUMENTS

Description & Manufacturer	Model No.	Serial No.	Calibrated Until
ROHDE&SCHWARZ SPECTRUM ANALYZER	FSEK30	100049	Aug. 12, 2005

NOTE:

The calibration interval of the above test instruments is 12 months and the calibrations are traceable to NML/ROC and NIST/USA.



5.5.3 TEST PROCEDURES

1. The transmitter output was connected to the spectrum analyzer.
2. Set RBW=1MHz, VBW=3MHz. The PPSD is the highest level found across the emission in any 1MHz band.

5.5.4 DEVIATION FROM TEST STANDARD

No deviation

5.5.5 TEST SETUP

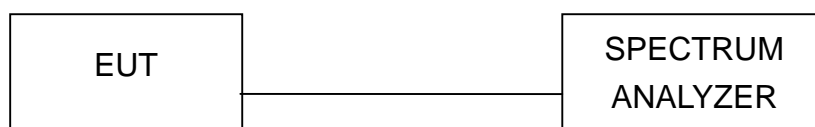

5.5.6 EUT OPERATING CONDITIONS

Same as 5.3.6



5.5.7 TEST RESULTS

EUT	MiniPCI 802.11a/b/g Wireless LAN Card	MODEL	Q802MIAG
ENVIRONMENTAL CONDITIONS	24deg. C, 64%RH, 991hPa	INPUT POWER (SYSTEM)	120Vac, 60 Hz
TESTED BY	Leo Hung		

CHANNEL NUMBER	CHANNEL FREQUENCY (MHz)	RF POWER LEVEL IN 1 MHz BW (dBm)	MAXIMUM LIMIT (dBm)	PASS/FAIL
1	5180	-2.01	4	PASS
4	5240	-1.86	4	PASS
5	5260	-1.76	11	PASS
8	5320	-1.29	11	PASS
9	5745	-1.90	17	PASS
12	5805	-1.86	17	PASS



CH 1

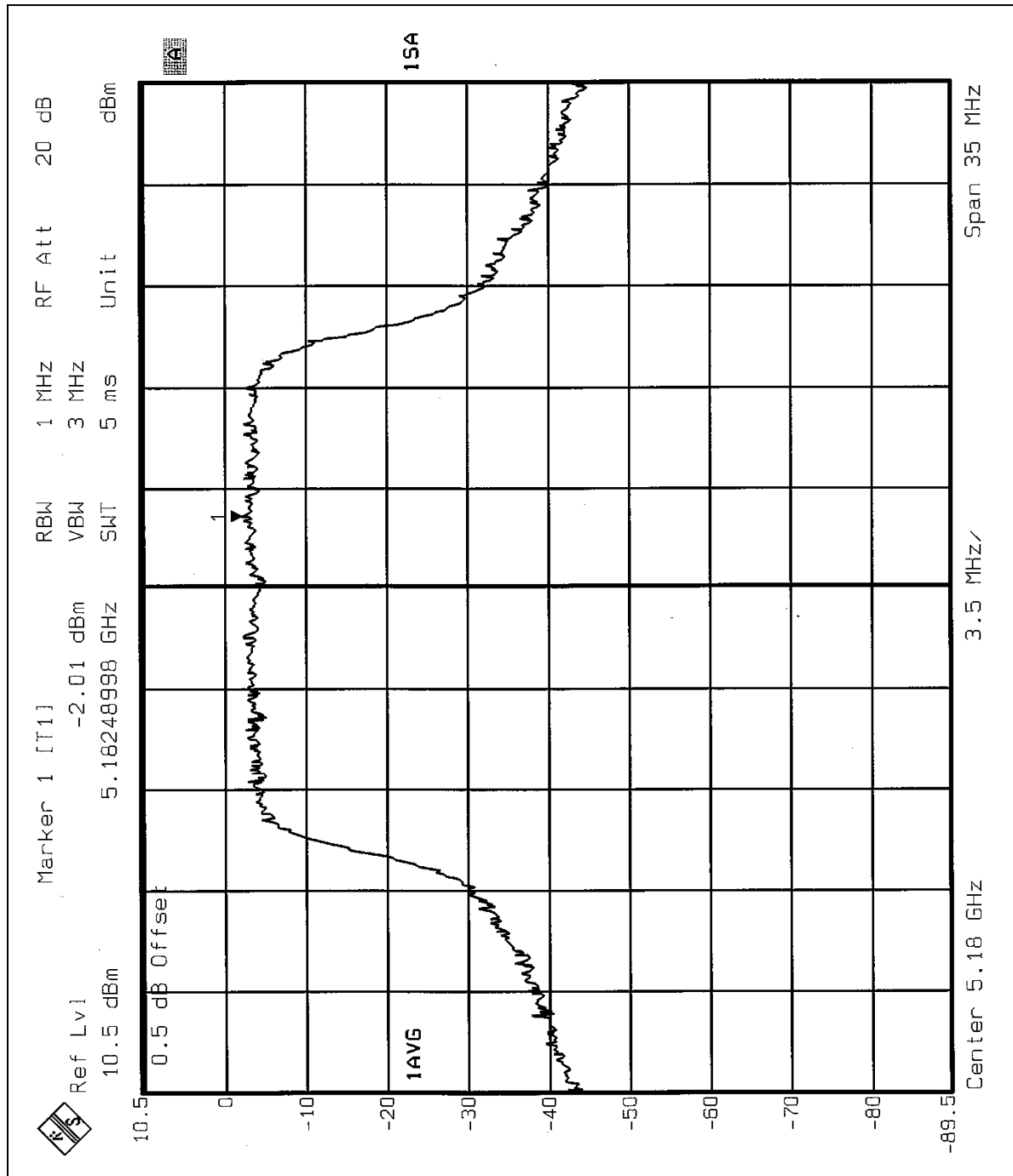



CH 4

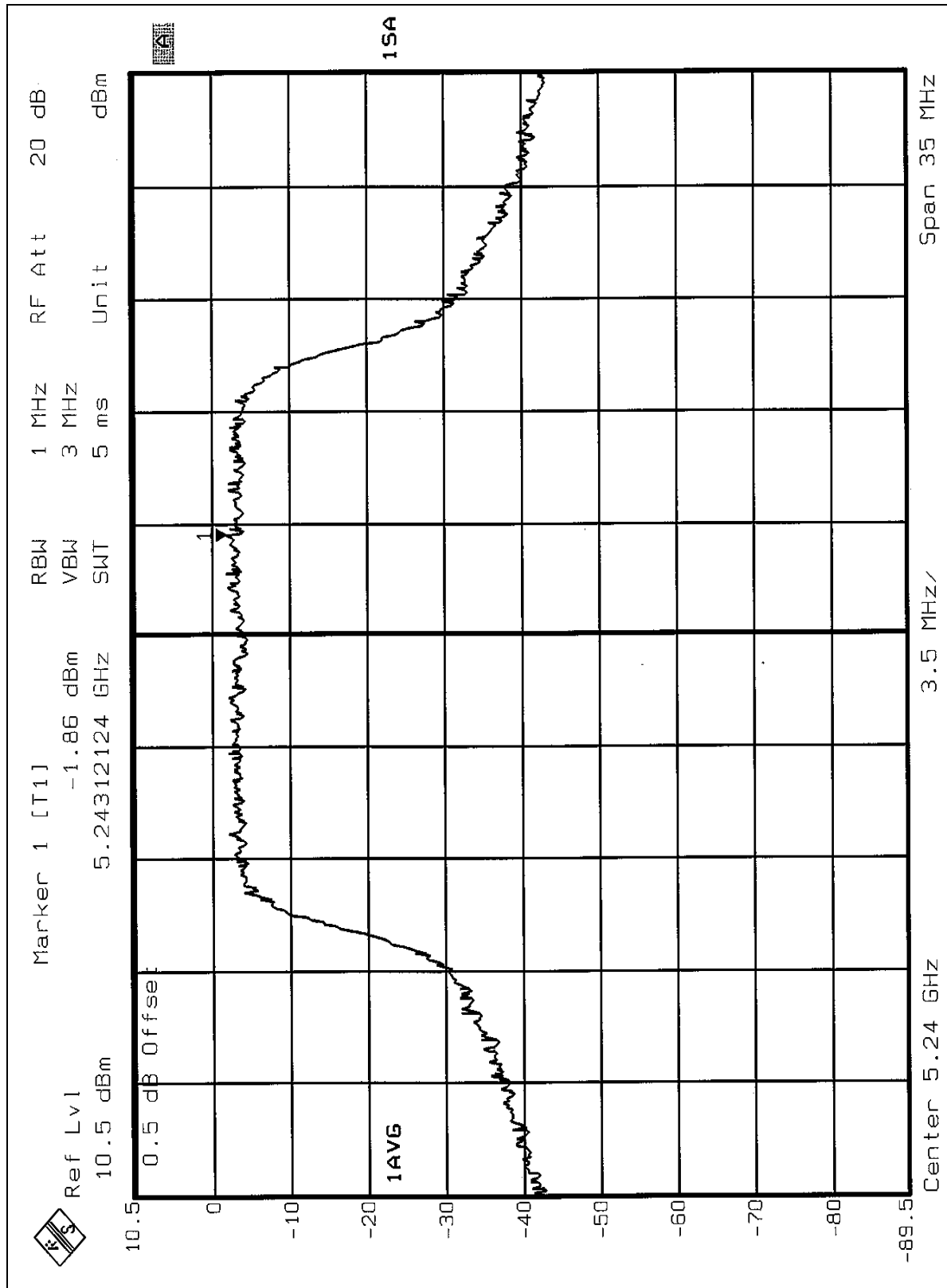



CH 5

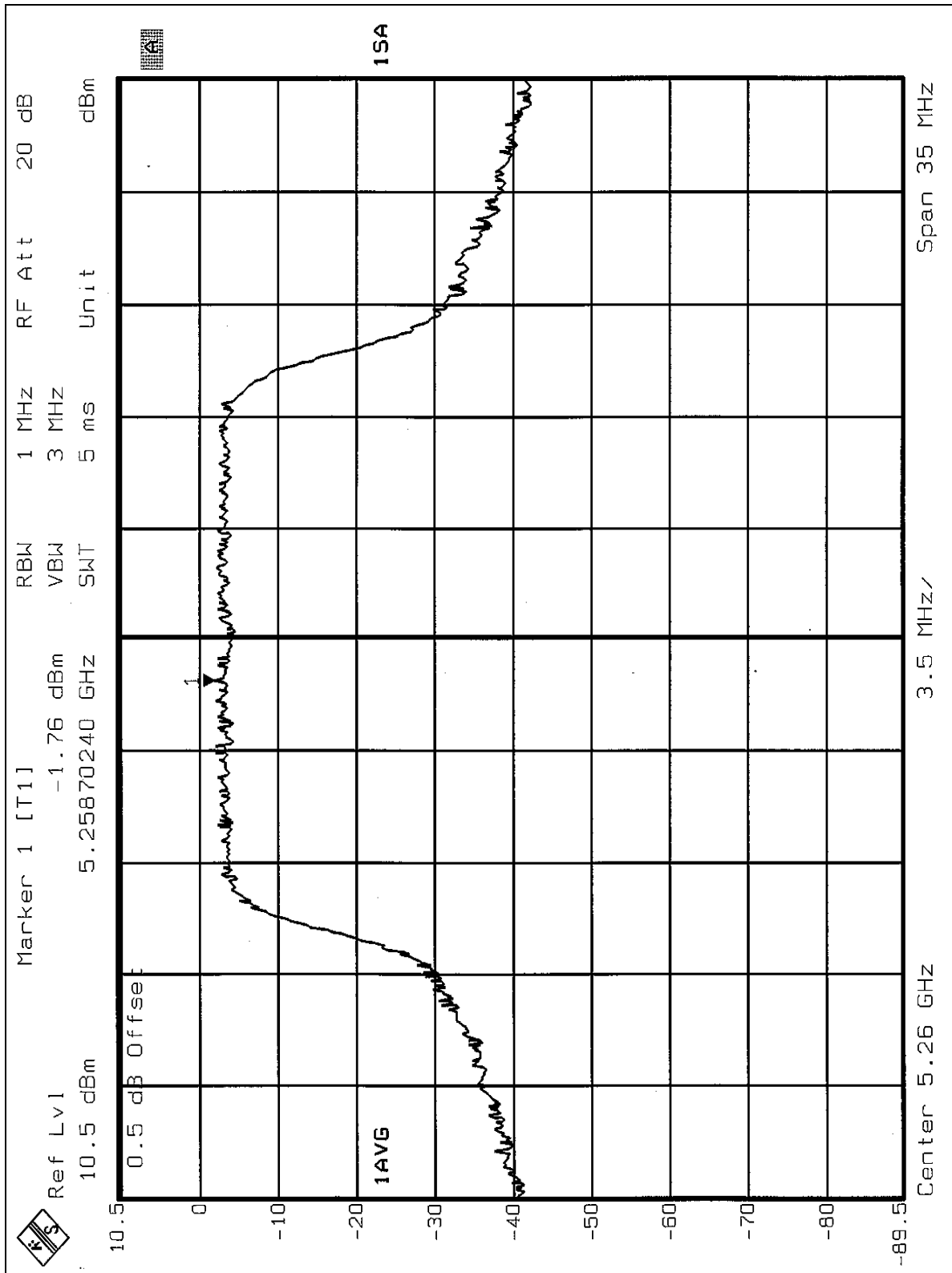



CH 8

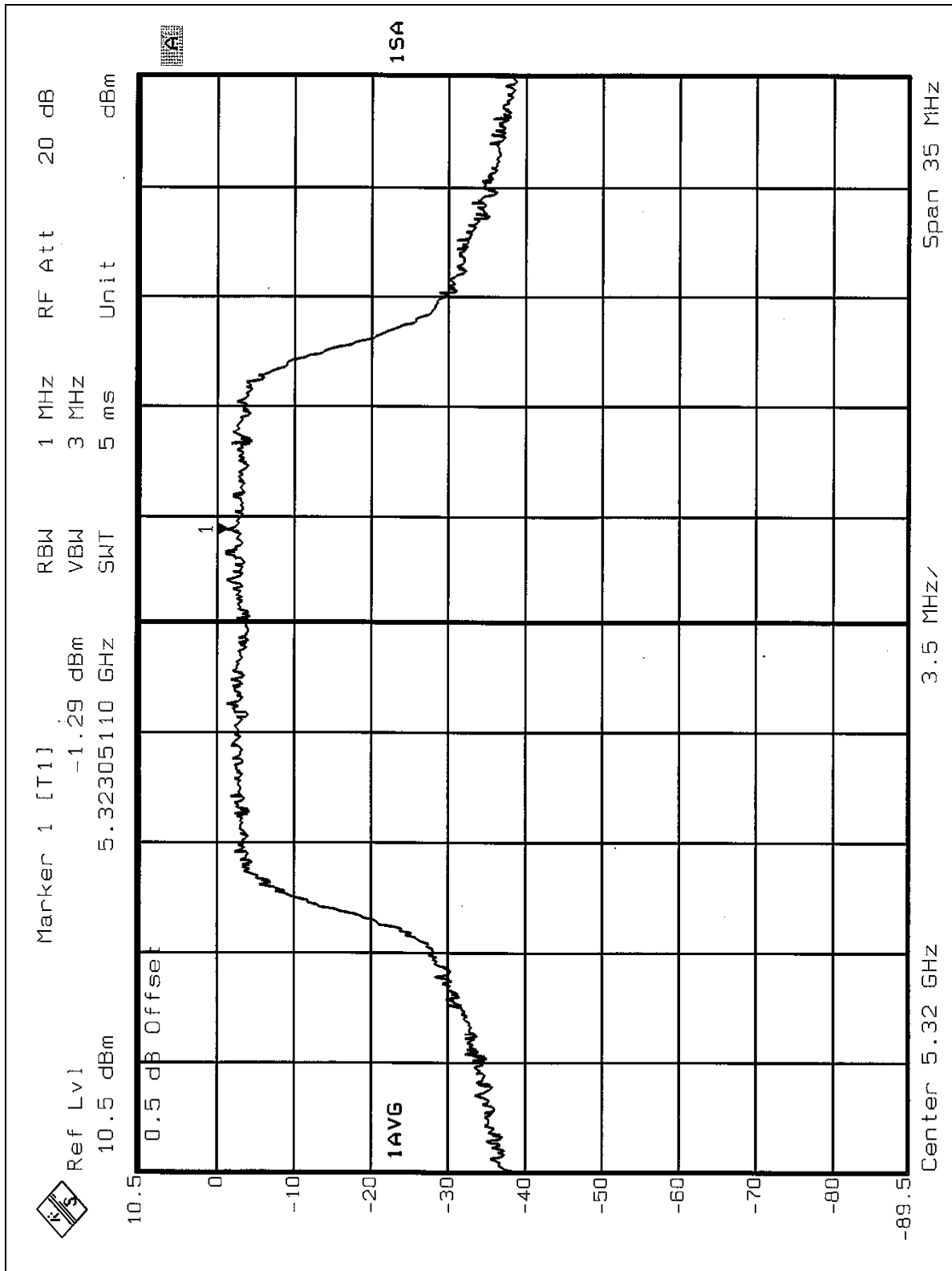



CH 9

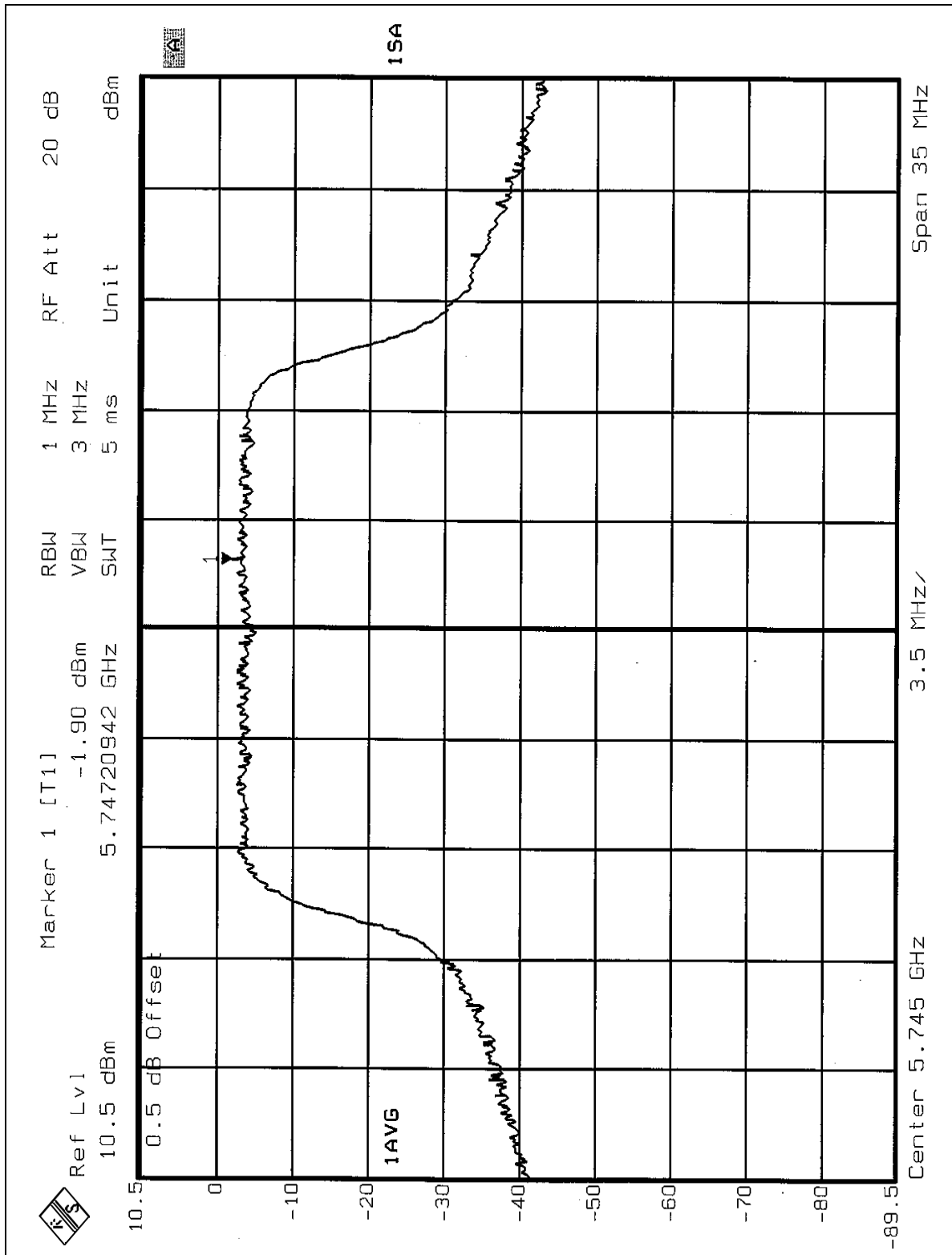



CH 12

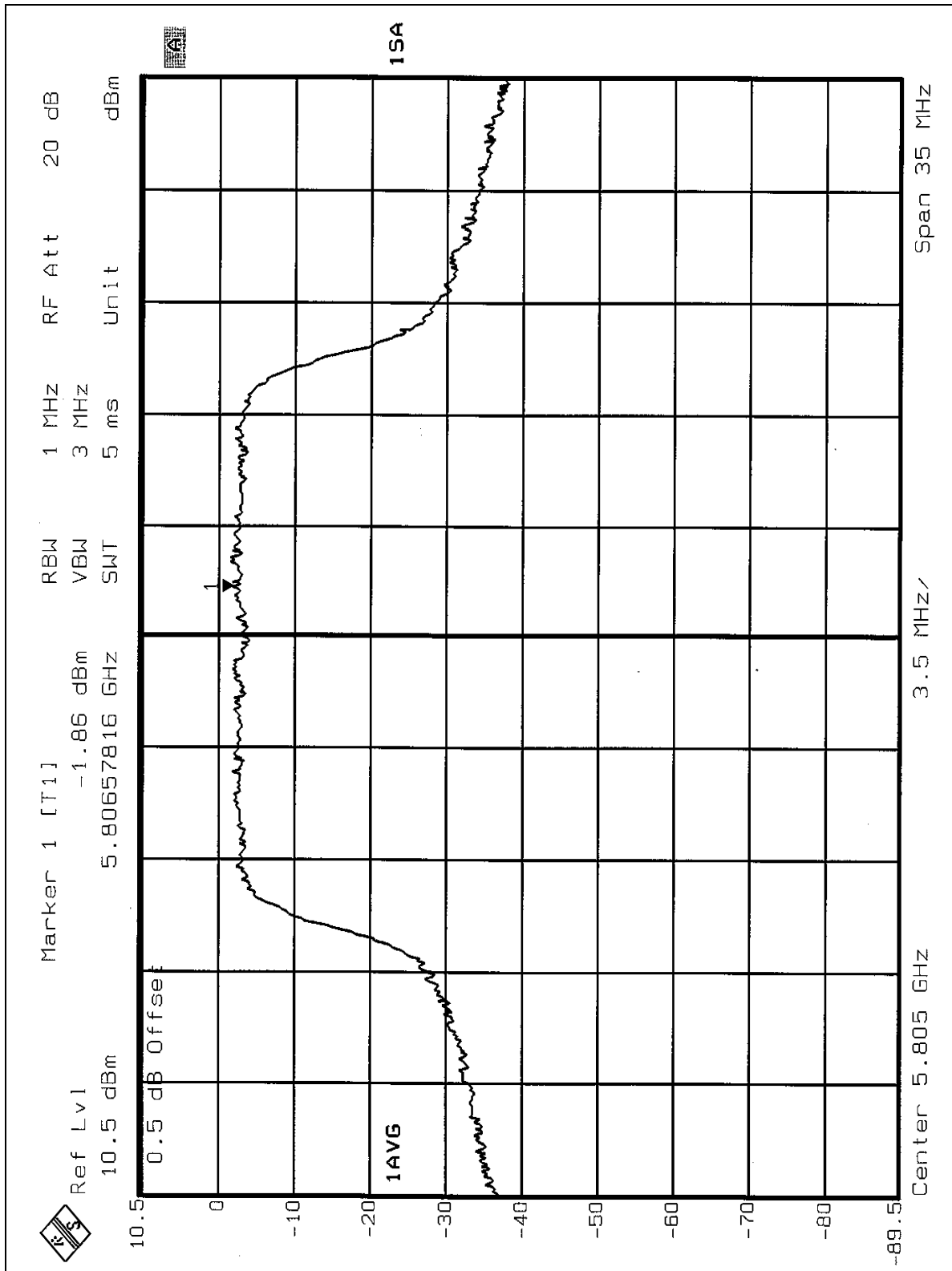



5.6 FREQUENCY STABILITY

5.6.1 LIMITS OF FREQUENCY STABILITY MEASUREMENT

The frequency tolerance of the carrier signal shall be maintained within +/- 0.02% of the operating frequency over a temperature variation of -30 degrees to 50 degrees C at normal supply voltage, and for a variation in the primary supply voltage from 85% to 115% of the rated supply voltage at a temperature of 20 degrees C.

5.6.2 TEST INSTRUMENTS

Description & Manufacturer	Model No.	Serial No.	Calibrated Until
ANRITSU SPECTRUM ANALYZER	MS2667C	M10281	Feb. 09, 2005
WIT STANDARD TEMPERATURE AND HUMIDITY CHAMBER	TH-4S-C	W981030	Jul. 18, 2005

NOTE: The calibration interval of the above test instruments is 12 months and the calibrations are traceable to NML/ROC and NIST/USA.

5.6.3 TEST PROCEDURE

1. The EUT was placed inside the environmental test chamber and powered by nominal DC voltage.
2. Turn the EUT on and couple its output to a spectrum analyzer.
3. Turn the EUT off and set the chamber to the highest temperature specified.
4. Allow sufficient time (approximately 30 min) for the temperature of the chamber to stabilize, turn the EUT on and measure the operating frequency after 2, 5, and 10 minutes.
5. Repeat step 2 and 3 with the temperature chamber set to the lowest temperature.
6. The test chamber was allowed to stabilize at +20 degree C for a minimum of 30 minutes. The supply voltage was then adjusted on the EUT from 85% to 115% and the frequency record.

5.6.4 DEVIATION FROM TEST STANDARD

No deviation

5.6.5 TEST SETUP

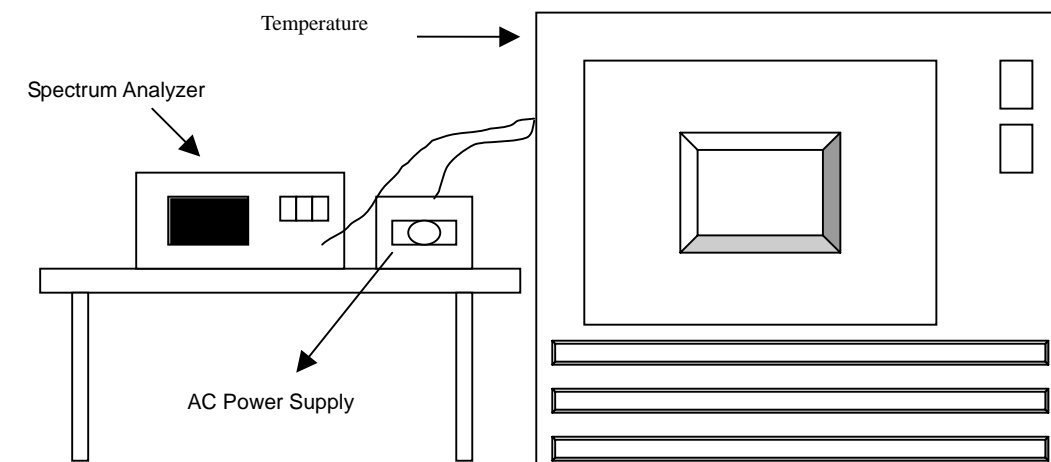

5.6.6 EUT OPERATING CONDITION

Same as Item 4.1.6



5.6.7 TEST RESULTS

		Operating frequency: 5320MHz				Limit : ± 0.01%	
Temp. (°C)	Power supply (VDC)	2 minute		5 minute		10 minute	
		(MHz)	(%)	(MHz)	(%)	(MHz)	(%)
50	93.5	5319.9510	-0.0009211	5319.9510	-0.0009211	5319.9500	-0.0009398
	110.0	5319.9510	-0.0009211	5319.9510	-0.0009211	5319.9510	-0.0009211
	126.5	5319.9510	-0.0009211	5319.9510	-0.0009211	5319.9510	-0.0009211
40	93.5	5319.9600	-0.0007519	5319.9600	-0.0007519	5319.9600	-0.0007519
	110.0	5319.9600	-0.0007519	5319.9600	-0.0007519	5319.9600	-0.0007519
	126.5	5319.9600	-0.0007519	5319.9600	-0.0007519	5319.9600	-0.0007519
30	93.5	5319.9760	-0.0004511	5319.9750	-0.0004699	5319.9750	-0.0004699
	110.0	5319.9760	-0.0004511	5319.9750	-0.0004699	5319.9750	-0.0004699
	126.5	5319.9760	-0.0004511	5319.9750	-0.0004699	5319.9750	-0.0004699
20	93.5	5319.9900	-0.0001880	5319.9900	-0.0001880	5319.9900	-0.0001880
	110.0	5319.9910	-0.0001692	5319.9900	-0.0001880	5319.9900	-0.0001880
	126.5	5319.9900	-0.0001880	5319.9900	-0.0001880	5319.9900	-0.0001880
10	93.5	5320.0050	0.0000940	5320.0040	0.0000752	5320.0040	0.0000752
	110.0	5320.0050	0.0000940	5320.0040	0.0000752	5320.0050	0.0000940
	126.5	5320.0040	0.0000752	5320.0040	0.0000752	5320.0050	0.0000940
0	93.5	5320.0180	0.0003383	5320.0200	0.0003759	5320.0240	0.0004511
	110.0	5320.0190	0.0003571	5320.0200	0.0003759	5320.0240	0.0004511
	126.5	5320.0190	0.0003571	5320.0200	0.0003759	5320.0230	0.0004323
-10	93.5	5320.0310	0.0005827	5320.0310	0.0005827	5320.0310	0.0005827
	110.0	5320.0310	0.0005827	5320.0310	0.0005827	5320.0300	0.0005639
	126.5	5320.0310	0.0005827	5320.0310	0.0005827	5320.0300	0.0005639
-20	93.5	5320.0300	0.0005639	5320.0290	0.0005451	5320.0290	0.0005451
	110.0	5320.0300	0.0005639	5320.0290	0.0005451	5320.0290	0.0005451
	126.5	5320.0300	0.0005639	5320.0290	0.0005451	5320.0290	0.0005451
-30	93.5	5320.0210	0.0003947	5320.0200	0.0003759	5320.0190	0.0003571
	110.0	5320.0210	0.0003947	5320.0200	0.0003759	5320.0190	0.0003571
	126.5	5320.0210	0.0003947	5320.0200	0.0003759	5320.0190	0.0003571



5.7 BAND EDGES MEASUREMENT

5.7.1 TEST INSTRUMENTS

Description & Manufacturer	Model No.	Serial No.	Calibrated Until
SPECTRUM ANALYZER	FSEK30	100049	Aug. 12, 2005

NOTE:

The calibration interval of the above test instruments is 12 months and the calibrations are traceable to NML/ROC and NIST/USA.

5.7.2 TEST PROCEDURE

The transmitter output was connected to the spectrum analyzer via a low lose cable. Set both RBW and VBW of spectrum analyzer to 1MHz with suitable frequency span including 100 MHz bandwidth from band edge. The band edges was measured and recorded.

5.7.3 EUT OPERATING CONDITION

The software provided by client to enable the EUT under transmission condition continuously at specific channel frequencies individually.

5.7.4 TEST RESULTS

For signals in the restricted bands above and below the 5.15 to 5.35GHz allocated band a measurement was made of the amplitude of the spurious emissions with respect to the intentional signals. The relative amplitude, in dBc, was applied to the average and peak filed strength of the intentional signal made on the OATS to calculate the field strength of the unintentional signals.

The spectrum plots (Average RBW=1MHz, VBW=10Hz) are attached on the following 4 pages.



Channel 1 (5180 MHz)

The band edge emission plot on the following page shows 51.71dBc (Average) / 50.96dBc (Peak) between carrier maximum power and local maximum emission in restrict band. The emission of carrier strength list in the test result of channel 1 is 99.11dBuV/m, so the maximum field strength in restrict band is 99.11-50.96=48.15dBuV/m which is under 54dBuV/m limit.

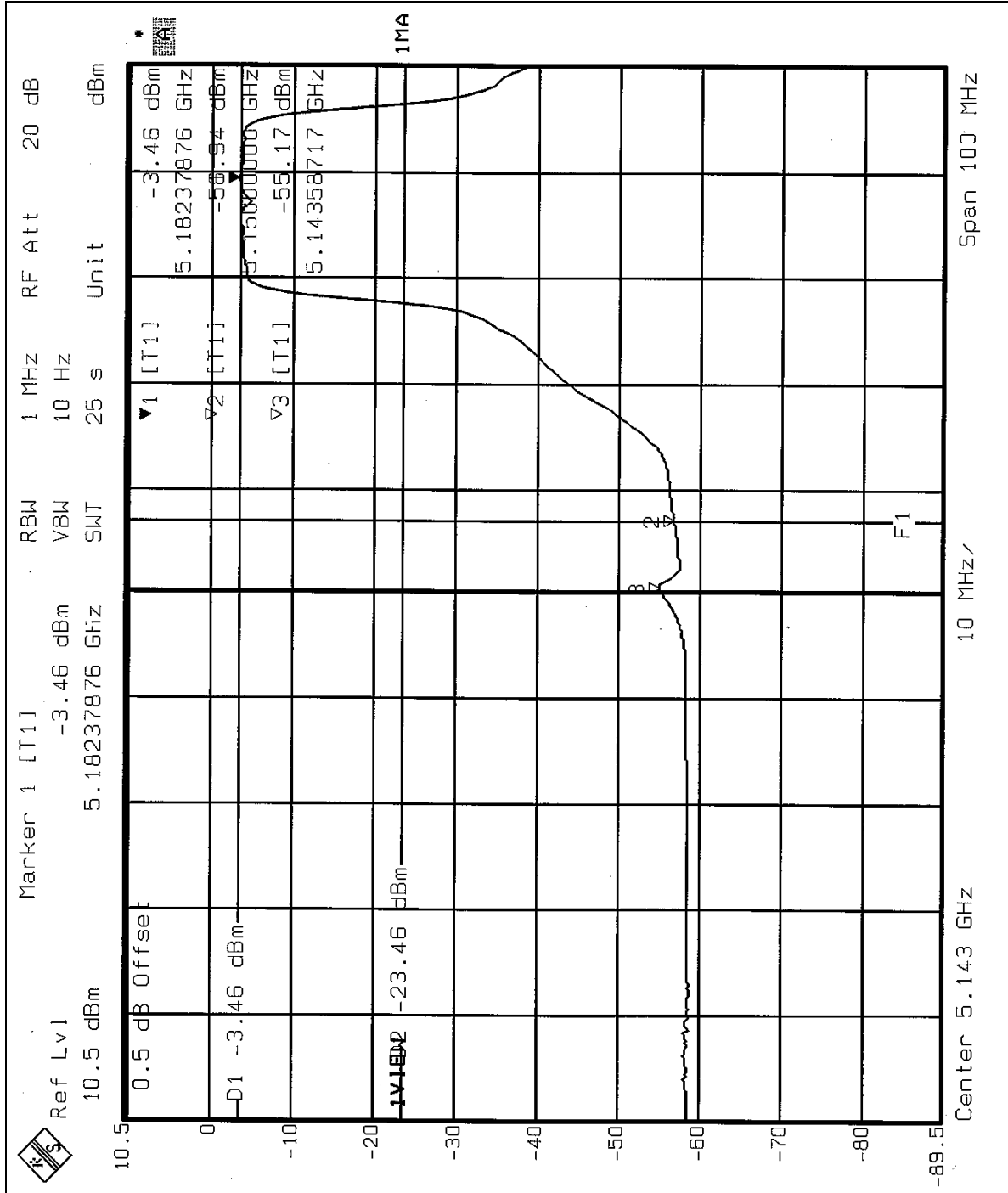

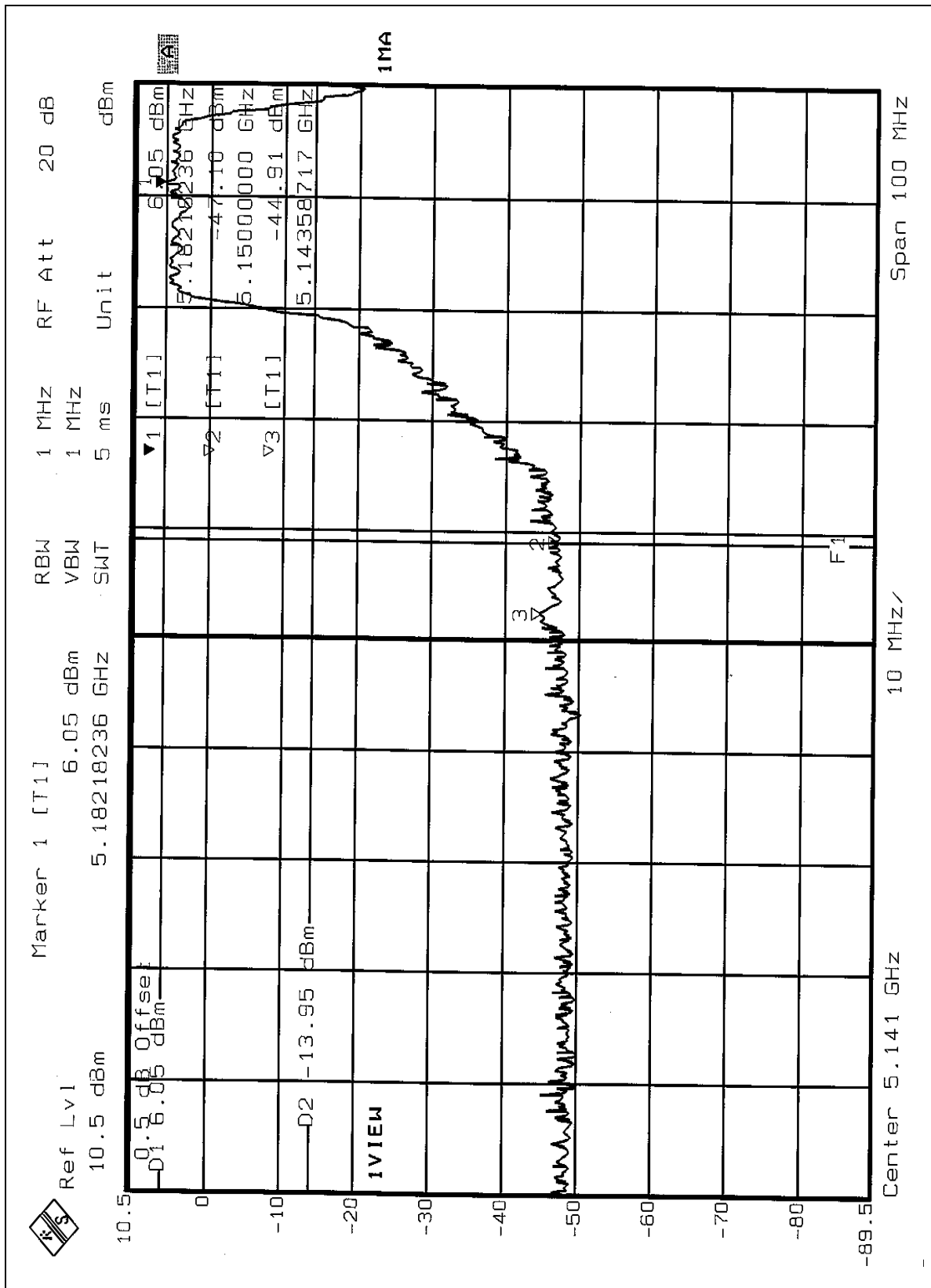



Channel 8 (5320 MHz)

The band edge emission plot on the following page shows 52.76dBc (Average) / 49.42dBc (Peak) between carrier maximum power and local maximum emission in restrict band. The emission of carrier strength list in the test result of channel 8 is 97.64dBuV/m, so the maximum field strength in restrict band is 97.64-52.76=44.88dBuV/m which is under 54dBuV/m limit.

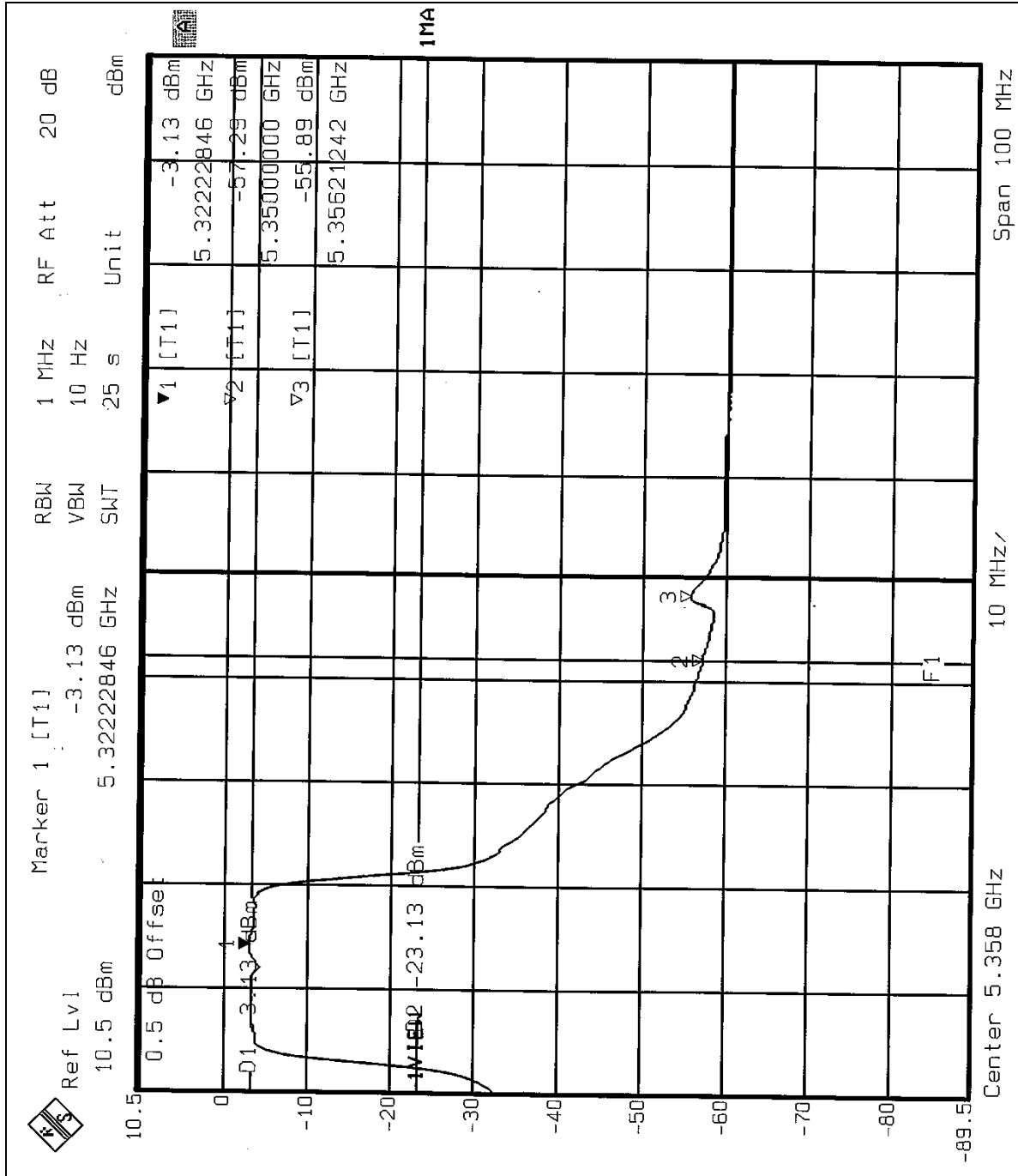

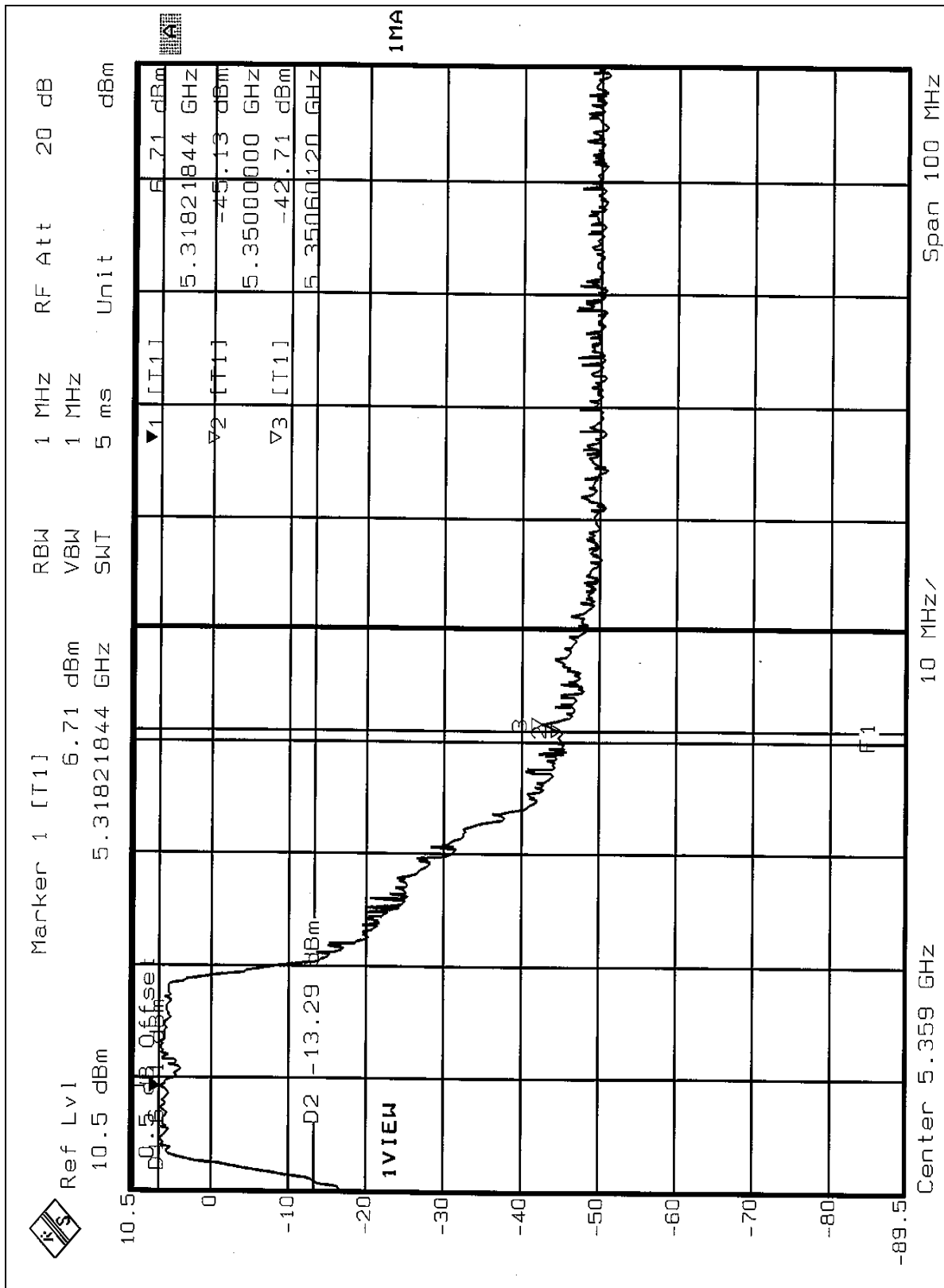



5.8 ANTENNA REQUIREMENT

5.8.1 STANDARD APPLICABLE

For intentional device, according to FCC 47 CFR Section 15.203, an intentional radiator shall be designed to ensure that no antenna other than that furnished by the responsible party shall be used with the device.

And according to FCC 47 CFR Section 15.407(a), if transmitting antennas of directional gain greater than 6dBi are used, the power shall be reduced by the amount in dB that the directional gain of the antenna exceeds 6dBi.

5.8.2 ANTENNA CONNECTED CONSTRUCTION

The antenna used in this product is PIFA antenna with UFL antenna connector. The maximum Gain of the antenna is 1.4dBi.

6. PHOTOGRAPHS OF THE TEST CONFIGURATION

CONDUCTED EMISSION TEST



RADIATED EMISSION TEST

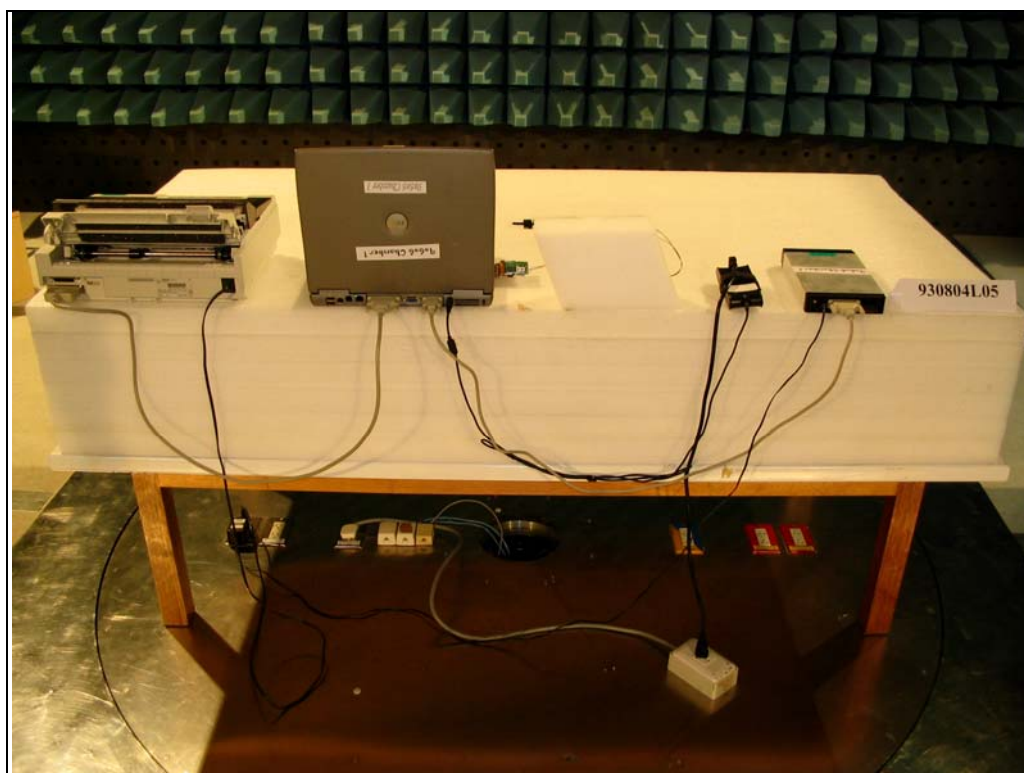
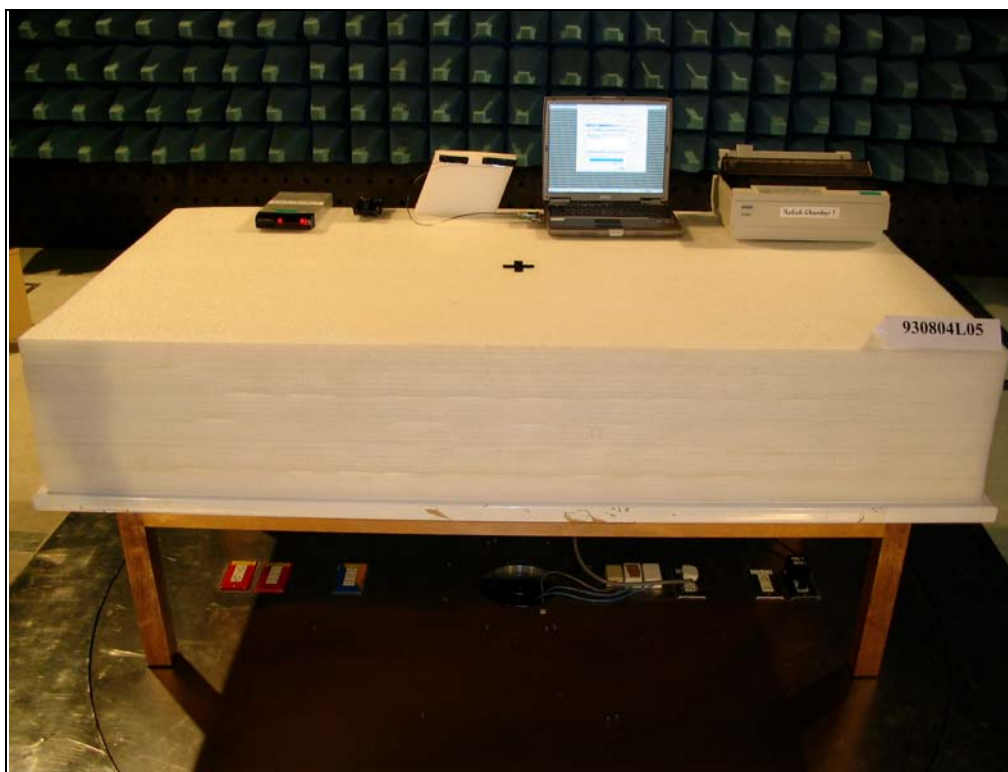





7. INFORMATION ON THE TESTING LABORATORIES

We, ADT Corp., were founded in 1988 to provide our best service in EMC, Radio, Telecom and Safety consultation. Our laboratories are accredited and approved by the following approval agencies according to ISO/IEC 17025, Guide 25 or EN 45001:

USA	FCC, NVLAP, UL, A2LA
Germany	TUV Rheinland
Japan	VCCI
Norway	NEMKO
Canada	INDUSTRY CANADA , CSA
R.O.C.	CNLA, BSMI, DGT
Netherlands	Telefication
Singapore	PSB , GOST-ASIA(MOU)
Russia	CERTIS(MOU)

Copies of accreditation certificates of our laboratories obtained from approval agencies can be downloaded from our web site:

www.adt.com.tw/index.5/phtml. If you have any comments, please feel free to contact us at the following:

Linko EMC/RF Lab:

Tel: 886-2-26052180

Fax: 886-2-26052943

Hsin Chu EMC/RF Lab:

Tel: 886-3-5935343

Fax: 886-3-5935342

Hwa Ya EMC/RF/Safety Telecom Lab:

Tel: 886-3-3183232

Fax: 886-3-3185050

Linko RF Lab.

Tel: 886-3-3270910

Fax: 886-3-3270892

Email: service@mail.adt.com.tw

Web Site: www.adt.com.tw

The address and road map of all our labs can be found in our web site also

Report Format Version 1.5