

EMC TEST REPORT

Report No. : EME-050742

Model No. : AWBC1D

Issued Date : Oct. 18, 2005

Applicant : Asia Pacific Microsystems, Inc.
No. 2, R&D Road 6, Science-Based Industrial Park,
Hsinchu, Taiwan.

Test By : Intertek Testing Services Taiwan Ltd.
No. 11, Lane 275, Ko-Nan 1 Street, Chia-Tung Li,
Shiang-Shan District, Hsinchu City, Taiwan

This test report consists of 36 pages in total. It may be duplicated completely for legal use with the allowance of the applicant. It shall not be reproduced except in full, without the written approval of Intertek Laboratory. The test result(s) in this report only applies to the tested sample(s).

Project Engineer

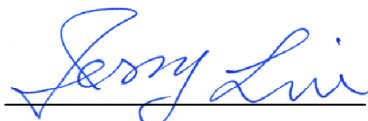

Jerry Liu

Reviewed By



Kevin Chen

Table of Contents

Summary of Tests 4

1. General information 5

 1.1 Identification of the EUT 5

 1.2 Additional information about the EUT 5

 1.3 Antenna description 6

 1.4 Peripherals equipment 6

2. Test specifications 7

 2.1 Test standard 7

 2.2 Operation mode 7

 2.3 Test equipment 8

3. 20dB Bandwidth test 9

 3.1 Operating environment 9

 3.2 Test setup & procedure 9

 3.3 Measured data of modulated bandwidth test results 9

4. Carrier Frequency Separation test 11

 4.1 Operating environment 11

 4.2 Test setup & procedure 11

 4.3 Measured data of Carrier Frequency Separation test result 11

5. Number of hopping frequencies test 13

 5.1 Operating environment 13

 5.2 Test setup & procedure 13

 5.3 Measured data of number of hopping frequencies test result 13

6. Time of Occupancy (dwell time) test 15

 6.1 Operating environment 15

 6.2 Test setup & procedure 15

7. Maximum Output Power test 19

 7.1 Operating environment 19

 7.2 Test setup & procedure 19

 7.3 Measured data of Maximum Output Power test results 19

8. Radiated Emission test 20

 8.1 Operating environment 20

 8.2 Test setup & procedure 20

8.3 Emission limits21

8.4 Radiated spurious emission test data.....22

8.4.1 Measurement results: frequencies equal to or less than 1 GHz.....22

8.4.2 Measurement results: frequency above 1GHz23

9. Emission on the band edge §FCC 15.247(C).....26

9.1 Band-edge (Conducted method).....27

9.2 Band-edge (Radiated method).....29

10. Power Line Conducted Emission test §FCC 15.20733

10.1 Operating environment.....33

10.2 Test setup & procedure.....33

10.3 Emission limit34

10.4 Uncertainty of Conducted Emission34

10.5 Power Line Conducted Emission test data.....35

Summary of Tests**Bluetooth V.1.2 Class1 USB Dongle-Model: AWBC1D
FCC ID: RU5AWBC1D**

Test	Reference	Results
Maximum Output Power test	15.247(b)	Complies
Carrier Frequency Separation test	15.247(a)(1)	Complies
Number of hopping frequencies test	15.247(a)(1)	Complies
Time of Occupancy (dwell time) test	15.247(a)(1)	Complies
20dB Bandwidth test	15.247(a)(1)	Complies
Radiated Spurious Emission test	15.205, 15.209	Complies
Emission on the Band Edge test	15.247(d)	Complies
AC Power Line Conducted Emission test	15.207	Complies

1. General information

1.1 Identification of the EUT

Applicant	: Asia Pacific Microsystems, Inc.
Product	: Bluetooth V.1.2 Class1 USB Dongle
Model No.	: AWBC1D
Trade Name	: APM
FCC ID.	: RU5AWBC1D
Frequency Range	: 2400MHz ~ 2483.5MHz
Channel Number	: 79 channels
Frequency of Each Channel	: 2402 + k MHz; k = 0-78
Type of Modulation	: GFSK
Rated Power	: DC 5V from Notebook PC
Power Cord	: N/A
Sample Received	: July 22, 2005
Test Date(s)	: July 22, 2005 ~ Oct. 14, 2005

A FCC DoC report has been generated for the client.

1.2 Additional information about the EUT

The EUT is a Bluetooth V.1.2 Class1 USB Dongle, and was defined as information technology equipment.

For more detail features, please refer to User's manual as file name "Installation guide.pdf"

1.3 Antenna description

The EUT uses a permanently connected antenna.

Antenna Gain : 2.22dBi max

Antenna Type : PCB Printed antenna

Connector Type : N/A

1.4 Peripherals equipment

Peripherals	Manufacturer	Product No.	Serial No.	FCC ID
Notebook PC	DELL	PP05L	CN-5G5152-48643-498-6810	FCC DoC Approved
Printer	DeskJet 400	TH86K1N2ZB	B94C2642X	FCC DoC Approved
Modem	LEMEL	MD-56KVT-100	00V230A00078422	FCC DoC Approved

2. Test specifications

2.1 Test standard

The EUT was performed according to the procedures in FCC Part 15 Subpart C Section § 15.205 、 §15.207 、 §15.209 、 §15.247 and ANSI C63.4/2003.

The test of radiated measurements according to FCC Part15 Section 15.33(a) had been conducted and the field strength of this frequency band were all meet limit requirement, thus we evaluate the EUT pass the specified test.

2.2 Operation mode

The EUT was transmitted continuously during the test.

2.3 Test equipment

Equipment	Brand	Frequency range	Model No.	Intertek ID No.	Next Cal. Date
EMI Test Receiver	Rohde & Schwarz	9kHz~2.75GHz	ESCS 30	EC303	04/17/2006
EMI Test Receiver	Rohde & Schwarz	20Hz~26.5GHz	ESMI	EC317	08/07/2006
Spectrum Analyzer	Rohde & Schwarz	9kHz~30GHz	FSP 30	EC353	07/24/2006
Spectrum Analyzer	Rohde & Schwarz	20Hz~40GHz	FSEK 30	EC365	10/17/2006
Horn Antenna	SCHWARZBECK	1GHz~18GHz	BBHA 9120 D	EC371	12/22/2007
Horn Antenna	SCHWARZBECK	14GHz~40GHz	BBHA 9170	EC351	07/08/2007
Bilog Antenna	SCHWARZBECK	25MHz~2GHz	VULB 9168	EC347	12/22/2007
Pre-Amplifier	MITEQ	100MHz~26.5GHz	919981	EC373	12/30/2005
Pre-Amplifier	MITEQ	26GHz~40GHz	828825	EC374	01/28/2006
Wideband Peak Power Meter/ Sensor	Anritsu	100MHz~18GHz	ML2497A/ MA2491A	EC396	10/17/2006
Controller	HDGmbH	N/A	CM 100	EP346	N/A
Antenna Tower	HDGmbH	N/A	MA 240	EP347	N/A
LISN	Rohde & Schwarz	9KHz~30MHz	ESH3-Z5	EC344	01/13/2006

Note: 1. The above equipments are within the valid calibration period.
 2. The test antennas (receiving antenna) are calibration per 3 years.

3. 20dB Bandwidth test

3.1 Operating environment

Temperature: 25 °C
Relative Humidity: 55 %
Atmospheric Pressure: 1023 hPa

3.2 Test setup & procedure

The 20dB bandwidth per FCC §15.247(a)(1)(i) was measured using a 50 ohm spectrum analyzer with the resolutions bandwidth set at 100 kHz, the video bandwidth \geq RBW, and the SPAN may equal to approximately 2 to 3 times the 20dB bandwidth. The test was performed at 3 channels (lowest, middle and highest channel). The maximum 20dB modulation bandwidth is in the following Table.

3.3 Measured data of modulated bandwidth test results

Channel	Frequency (MHz)	Bandwidth (kHz)	Limit
Channel 40	2441.000	926.854	1MHz

Please see the plot below.

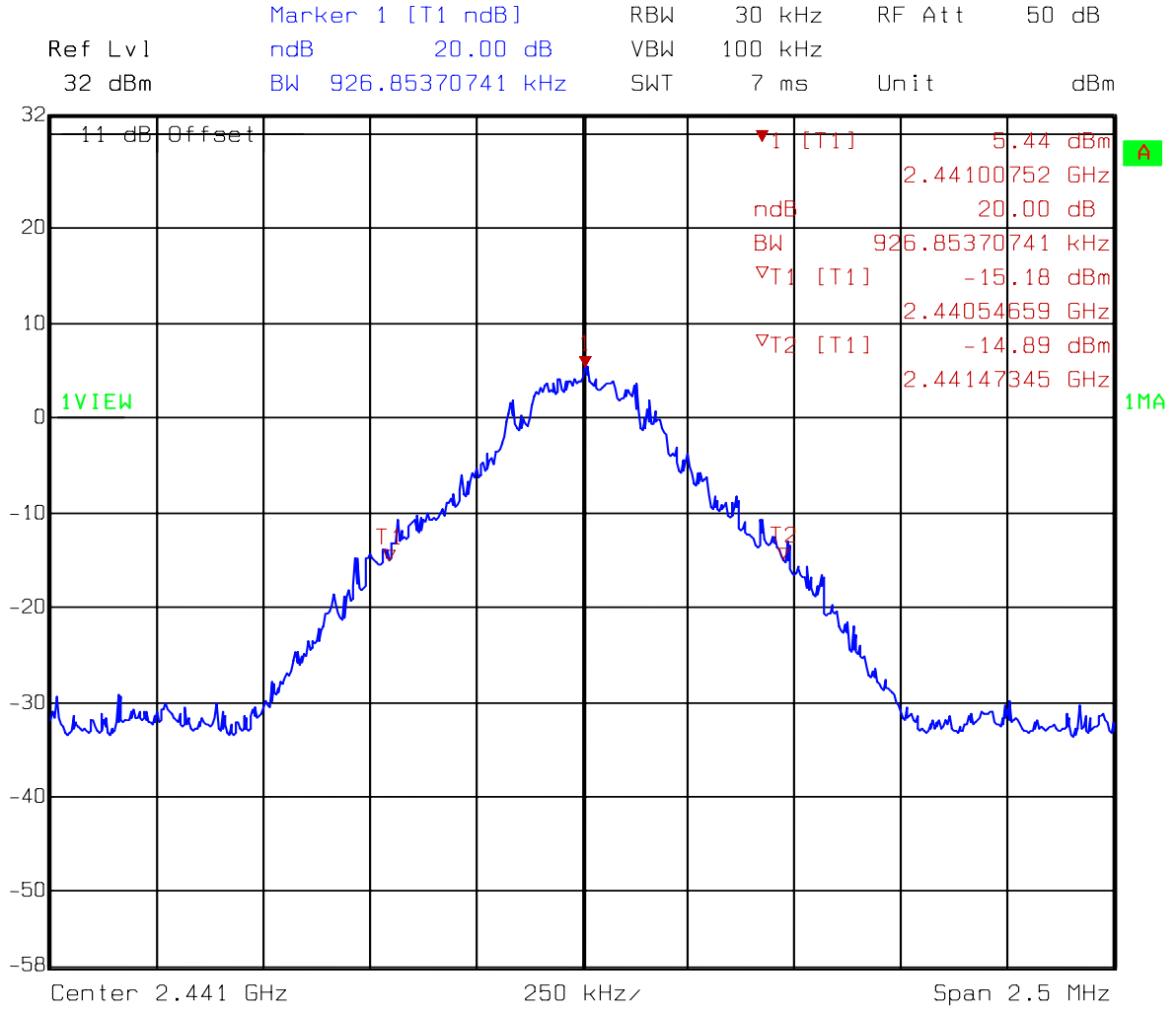

Comment A: 20dB Bandwidth
Date: 28.SEP.2005 17:09:39

4. Carrier Frequency Separation test

4.1 Operating environment

Temperature: 25 °C
Relative Humidity: 55 %
Atmospheric Pressure: 1023 hPa

4.2 Test setup & procedure

The carrier frequency separation per FCC §15.247(a)(1) was measured using a 50 ohm spectrum analyzer with the resolutions bandwidth set at $\geq 1\%$ of the span, the video bandwidth \geq RBW, and the SPAN was wide enough to capture the peaks of two adjacent channels. The carrier frequency separation result is in the following Table.

4.3 Measured data of Carrier Frequency Separation test result

Channel	Frequency (MHz)	Measurement Frequency separation (kHz)
1	2402	997.995
2	2403	

Please see the plot below.

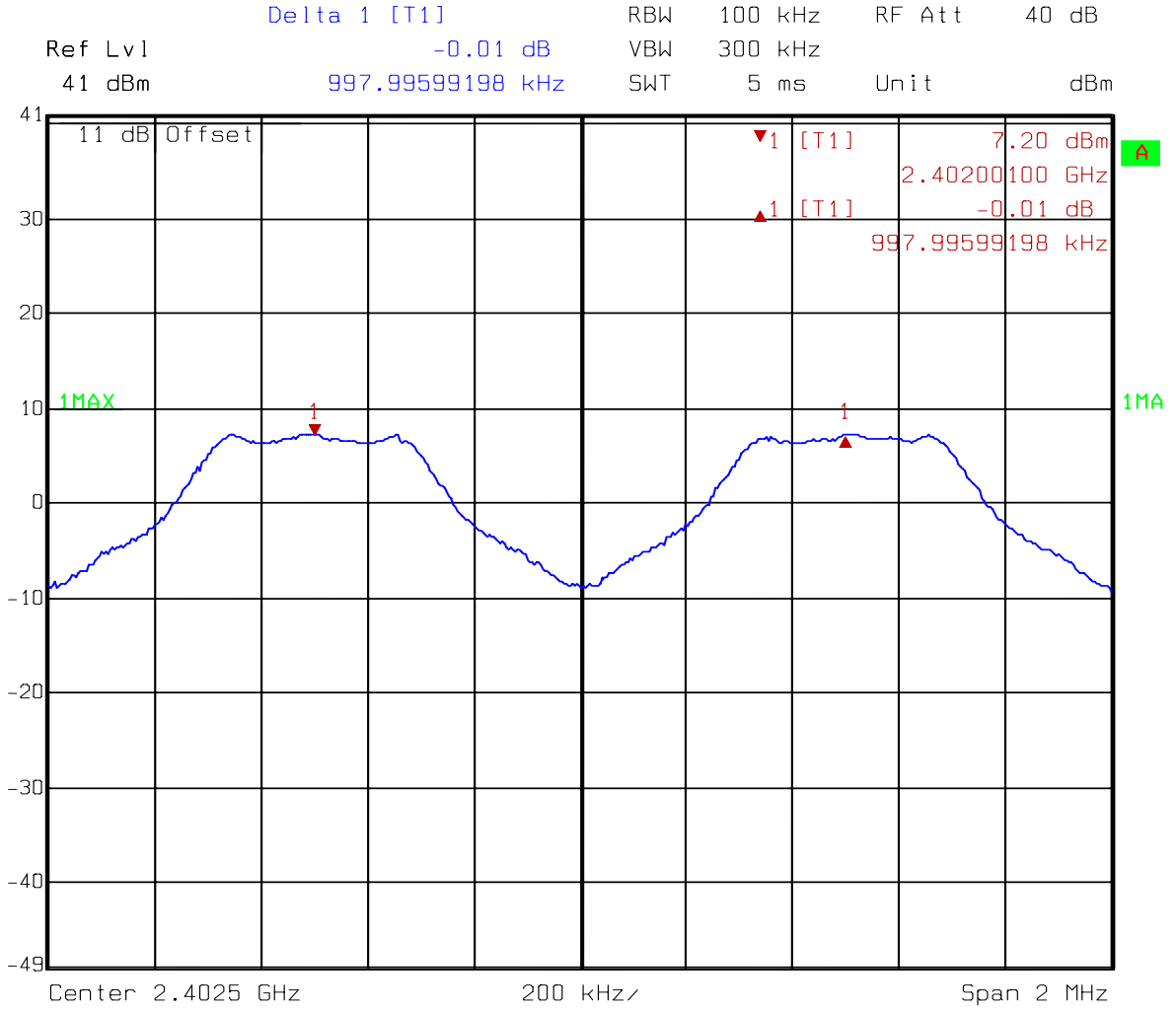

Comment A: Carrier frequencies separation between CH1 and CH2
Date: 28.SEP.2005 16:54:40

5. Number of hopping frequencies test

5.1 Operating environment

Temperature: 25 °C
Relative Humidity: 55 %
Atmospheric Pressure: 1023 hPa

5.2 Test setup & procedure

The number of hopping frequencies per FCC §15.247(a)(1) was measured using a 50 ohm spectrum analyzer with the resolutions bandwidth set at $\geq 1\%$ of the span, the video bandwidth \geq RBW, and the SPAN was the frequency band of operation. The carrier frequency separation result is in the following Table.

5.3 Measured data of number of hopping frequencies test result

Frequency Range (MHz)	Total hopping channels
2400 ~ 2483.5	79

Please see the plot below.

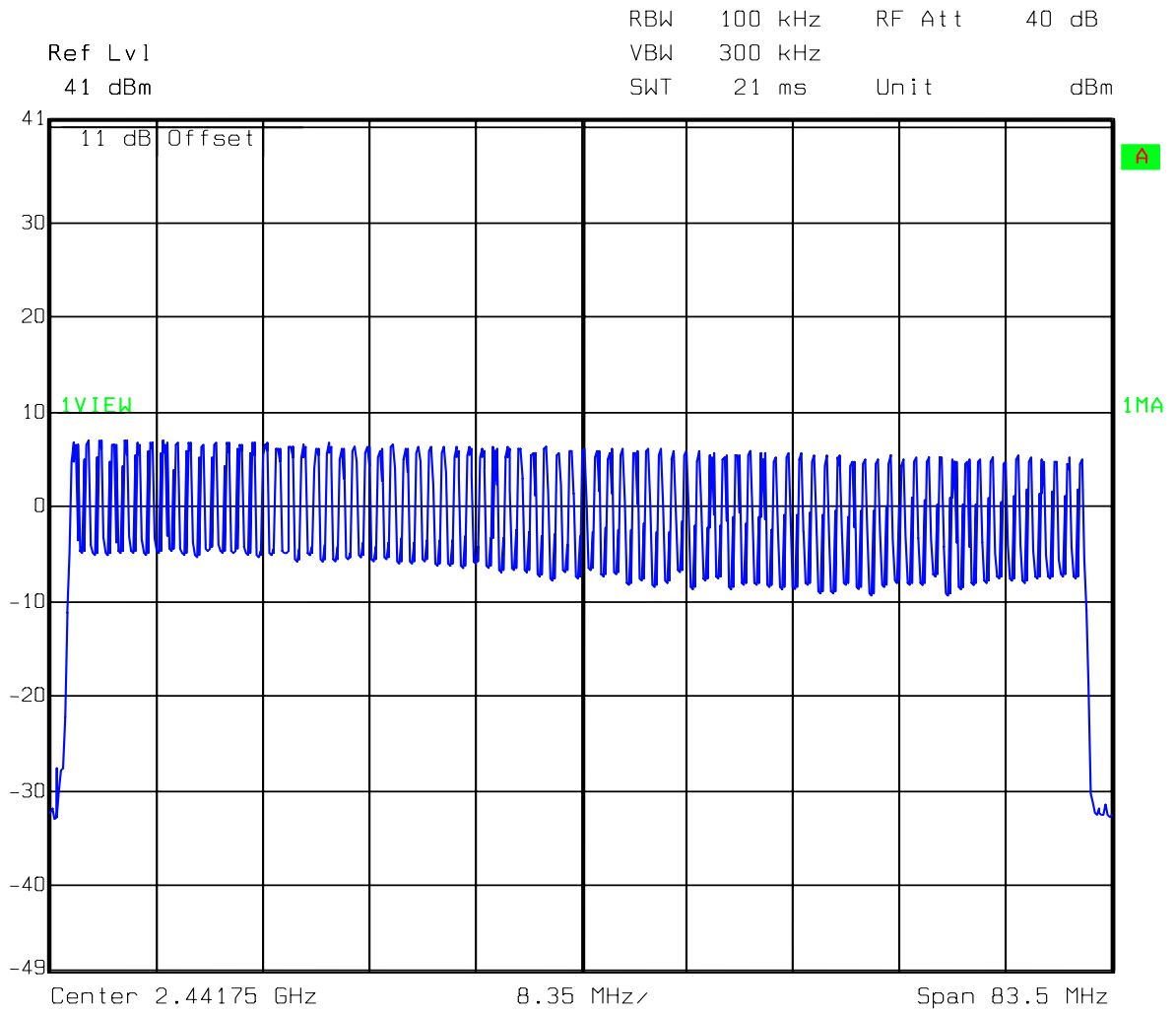

Comment A: No. of hopping frequencies
Date: 28.SEP.2005 17:00:56

6. Time of Occupancy (dwell time) test

6.1 Operating environment

Temperature: 25 °C
Relative Humidity: 55 %
Atmospheric Pressure: 1023 hPa

6.2 Test setup & procedure

The time of occupancy (dwell time) per FCC §15.247(a)(1) was measured using a 50 ohm spectrum analyzer with the resolutions bandwidth set at 1MHz, the video bandwidth \geq RBW, and the zero span function of spectrum analyzer was enable. The EUT has its hopping function enable.

The system makes worst case 1600 hops per second or 1 time slot has a length of 625 μ s with 79 channels.

Time of occupancy (dwell time) for DH1

$$\begin{aligned} \text{Dwell time} &= 400.801 \mu\text{s} * 1600 * 1/2 * 1/\text{s} / 79 * 31.6\text{s} \\ &= 128.256 \text{ ms (in a 31.6s period)} \end{aligned}$$

Time of occupancy (dwell time) for DH3

$$\begin{aligned} \text{Dwell time} &= 1.656 \text{ ms} * 1600 * 1/4 * 1/\text{s} / 79 * 31.6\text{s} \\ &= 246.959 \text{ ms (in a 31.6s period)} \end{aligned}$$

Time of occupancy (dwell time) for DH5

$$\begin{aligned} \text{Dwell time} &= 2.922 \text{ ms} * 1600 * 1/6 * 1/\text{s} / 79 * 31.6\text{s} \\ &= 311.679 \text{ ms (in a 31.6s period)} \end{aligned}$$

Please see the plot below.

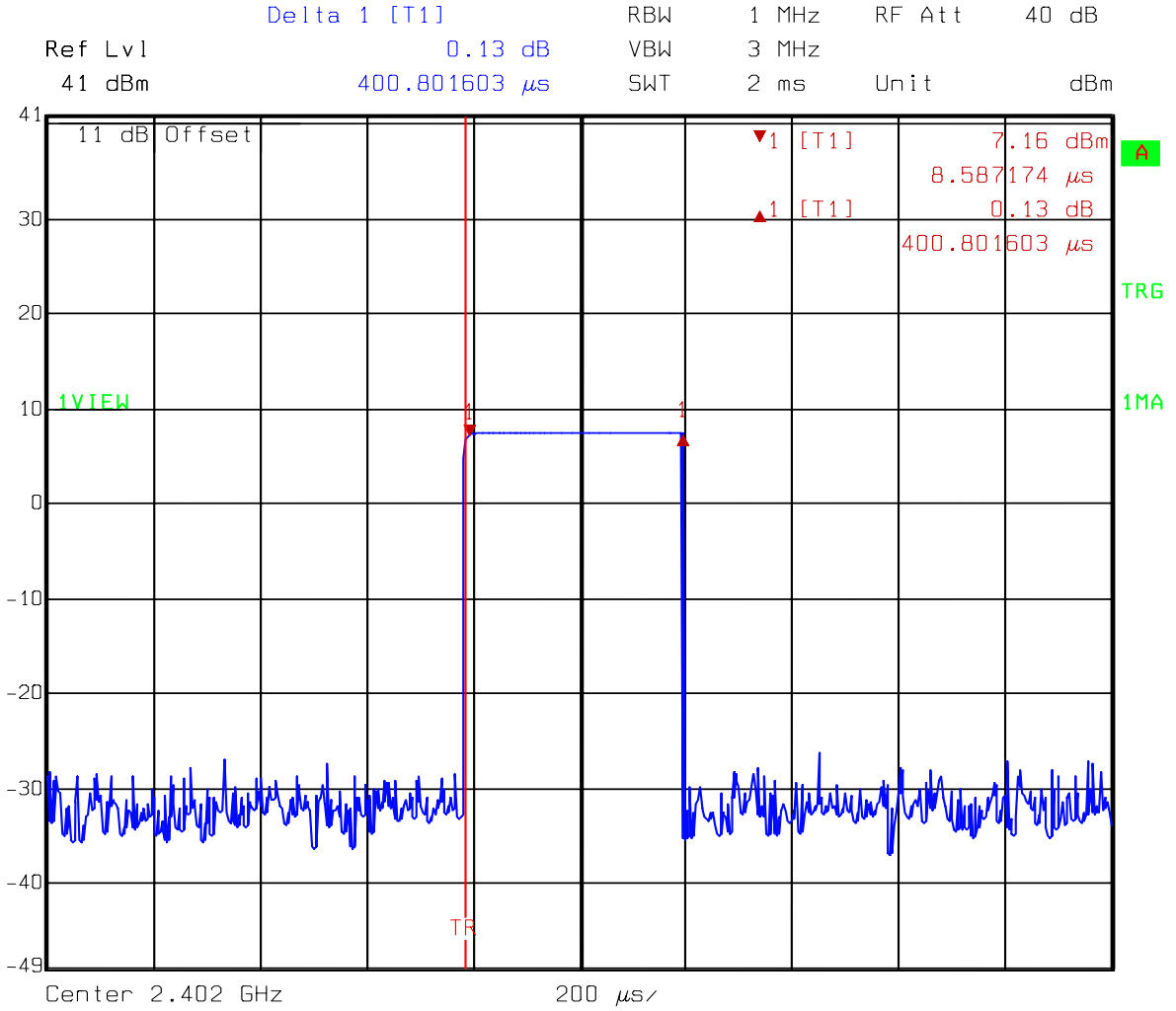

Comment A: Dwell time of DH1 mode
Date: 28.SEP.2005 16:40:26

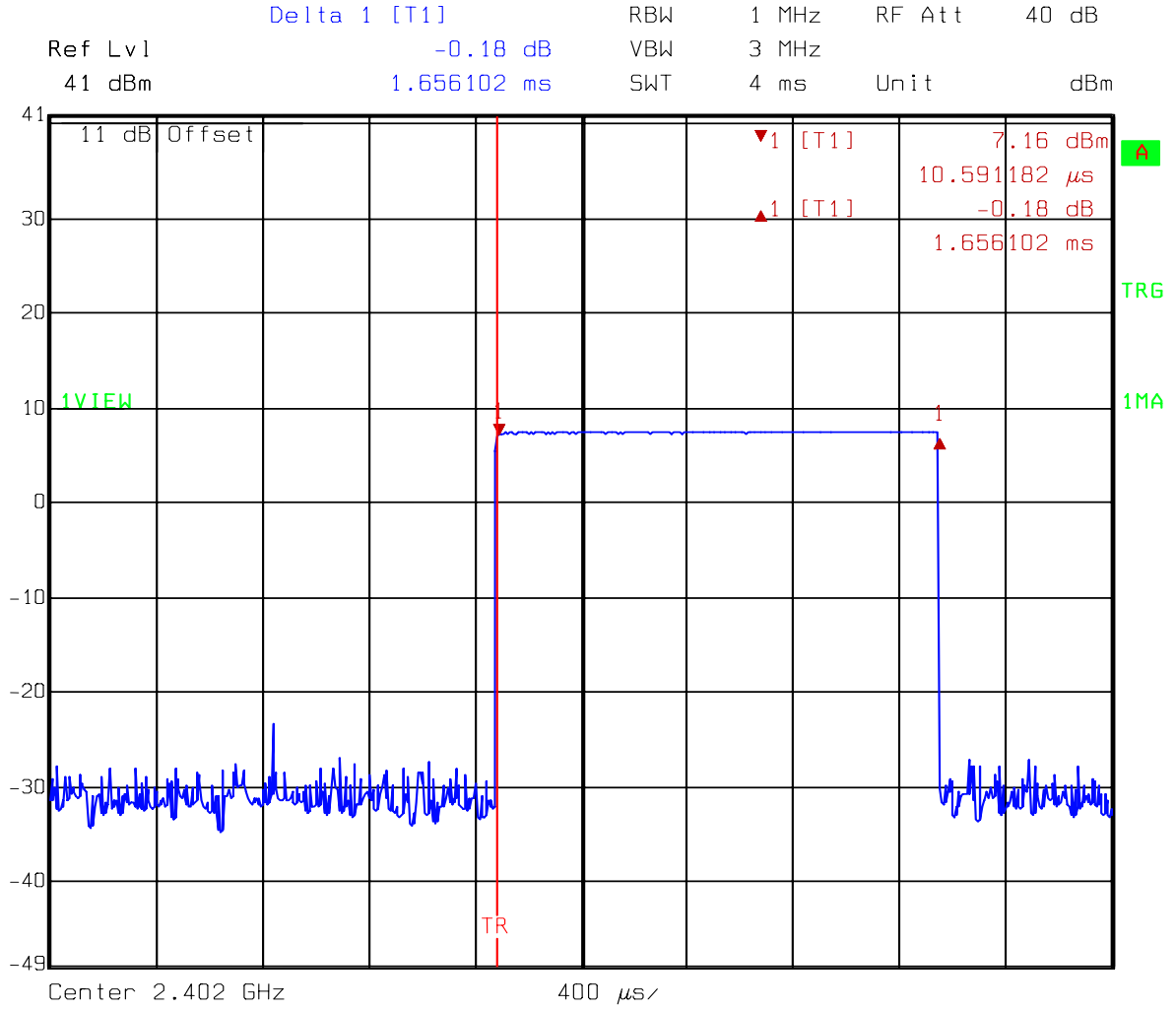

Comment A: Dwell time of DH3 mode
Date: 28.SEP.2005 16:42:24

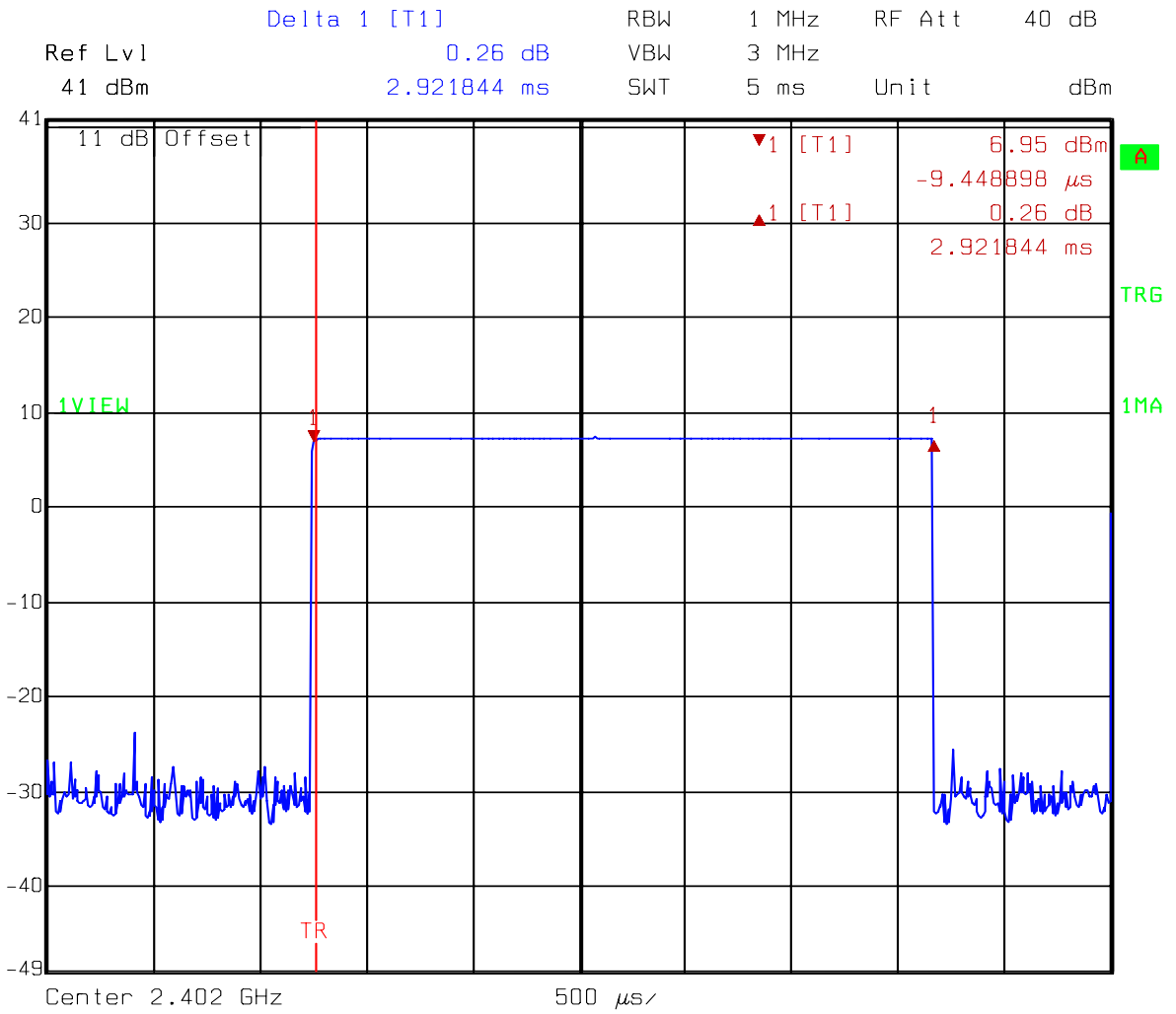

Comment A: Dwell time of DH5 mode
Date: 28.SEP.2005 16:43:46

7. Maximum Output Power test

7.1 Operating environment

Temperature: 25 °C
 Relative Humidity: 50 %
 Atmospheric Pressure: 1022 hPa

7.2 Test setup & procedure

The power output per FCC §15.247(b) was measured on the EUT using a 50 ohm SMA cable connected to peak power meter via power sensor. Power was read directly and cable loss correction (1.2 dB) was added to the reading to obtain power at the EUT antenna terminals. The test was performed at 3 channels (lowest, middle and highest channel).

7.3 Measured data of Maximum Output Power test results

Channel	Freq. (MHz)	C.L. (dB)	Reading (dBm)	Conducted Peak Output Power		Limit (W)
				(dBm)	(mW)	
1 (lowest)	2402	1.2	7.93	9.13	8.18	1
40 (middle)	2441	1.2	7.44	8.64	7.31	1
79 (highest)	2480	1.2	6.95	8.15	6.53	1

Remark:

Conducted Peak Output Power = Reading + C.L.

8. Radiated Emission test

8.1 Operating environment

Temperature: 23 °C
Relative Humidity: 53 %
Atmospheric Pressure: 1023 hPa

8.2 Test setup & procedure

The Diagram below shows the test setup, which is utilized to make these measurements.

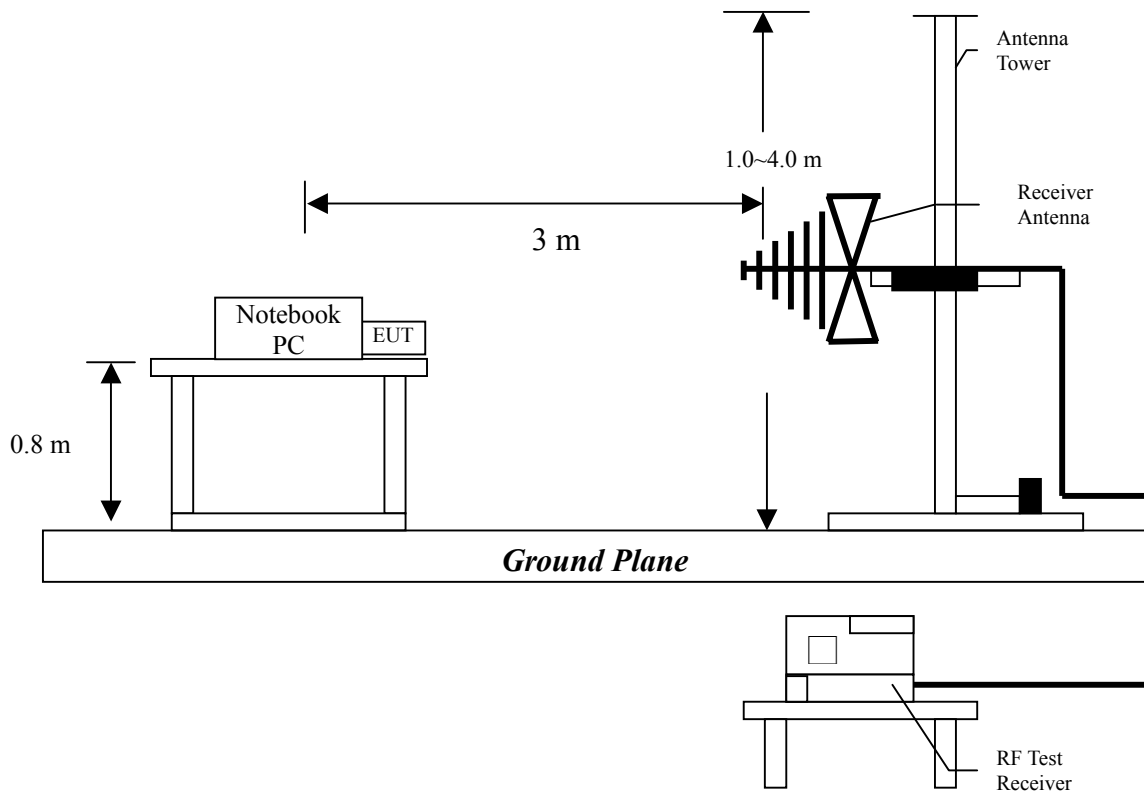

Radiated emissions were investigated cover the frequency range from 30MHz to 1000MHz using a receiver RBW of 120kHz record QP reading, and the frequency over 1GHz using a spectrum analyzer RBW of 1MHz and 10Hz VBW record Average reading. (15.209 paragraph), the Peak reading (1MHz RBW/VBW) recorded also on the report.

The EUT for testing is arranged on a wooden turntable. If some peripherals apply to the EUT, the peripherals will be connected to EUT and the whole system. During the test, all cables were arranged to produce worst-case emissions. The signal is maximized through rotation. The height of antenna and polarization is changing constantly for exploring for maximum signal level. The height of antenna can be up to 4 meters and down to 1 meter.

The measurement for radiated emission will be done at the distance of three meters unless the signal level is too low to measure at that distance. In the case of the reading under noise floor, a pre-amplifier is used and/or the test is conducted at a closer distance. And then all readings are extrapolated back to the equivalent 3 meter reading using inverse scaling with distance.

The EUT configuration please refer to the “Spurious set-up photo.pdf”.

8.3 Emission limits

The spurious Emission shall test through the 10th harmonic. In addition, radiated emissions which fall in the restricted bands, as defined in §15.205(a), must also comply with the radiated emission limits specified in §15.209(a).

Frequency (MHz)	Limits (dB μ V/m@3m)
30-88	40
88-216	43.5
216-960	46
Above 960	54

Remark:

1. In the above table, the tighter limit applies at the band edges.
2. Distance refers to the distance in meters between the measuring instrument antenna and the closed point of any part of the device or system

Uncertainty was calculated in accordance with NAMAS NIS 81.

Expanded uncertainty (k=2) of radiated emission measurement is 4.98 dB.

8.4 Radiated spurious emission test data

8.4.1 Measurement results: frequencies equal to or less than 1 GHz

EUT : AWBC1D
 Test Condition : Normal operating mode

Antenna Polariz. (V/H)	Freq. (MHz)	Receiver Detector	Corr. Factor (dB/m)	Reading (dBuV)	Corrected Level (dBuV/m)	Limit @ 3 m (dBuV/m)	Margin (dB)	Antenna high (cm)	Turn Table angle (degree)
V	101.780	QP	9.03	18.22	27.25	43.50	-16.26	100.00	133.00
V	338.460	QP	14.40	14.27	28.67	46.00	-17.34	100.00	11.00
V	365.620	QP	15.48	11.55	27.03	46.00	-18.98	100.00	25.00
V	400.540	QP	16.81	11.84	28.65	46.00	-17.35	100.00	69.00
V	664.380	QP	21.52	7.98	29.50	46.00	-16.51	100.00	178.00
V	730.340	QP	22.95	6.65	29.60	46.00	-16.40	100.00	160.00
H	101.780	QP	7.64	26.69	34.33	43.50	-9.17	400.00	83.00
H	171.620	QP	14.96	9.11	24.07	43.50	-19.44	400.00	328.00
H	299.660	QP	13.95	8.55	22.50	46.00	-23.50	356.00	318.00
H	346.220	QP	14.98	19.00	33.98	46.00	-12.02	227.00	252.00
H	575.140	QP	20.71	7.83	28.54	46.00	-17.46	153.00	350.00
H	666.320	QP	21.50	6.46	27.96	46.00	-18.04	137.00	344.00

Remark:

1. Corr. Factor = Antenna Factor + Cable Loss
2. Corrected Level = Reading + Corr. Factor

8.4.2 Measurement results: frequency above 1GHz

EUT : AWBC1D
 Test Condition : Tx at channel 1

Frequency (MHz)	Spectrum Analyzer Detector	Antenna Polariz. (H/V)	Preamp. Gain (dB)	Correction Factor (dB/m)	Reading (dBuV)	Corrected Level (dBuV/m)	Limit @ 3 m (dBuV/m)	Margin (dB)	Ant. high (cm)	Turn Table angle (degree)
4800.000	PK	V	36.07	37.77	42.48	44.18	54.00	-9.82	161.00	337.00
4800.000	PK	H	36.07	37.77	42.23	43.93	54.00	-10.07	171.00	339.00

Remark:

1. Correction Factor = Antenna Factor + Cable Loss
2. Corrected Level = Reading + Correction Factor – Preamp. Gain
3. The frequency measured ranges from 1GHz to 25GHz. The data value listed above which is higher than the noise floor, the others please refer to noise floor level.

Noise floor level is:

For PK:

- 1GHz-3GHz: 20dBuV
- 3GHz-14GHz: 27dBuV
- 14GHz-26.5GHz: 39dBuV

For AV:

- 1GHz-3GHz: 10dBuV
- 3GHz-14GHz: 16dBuV
- 14GHz-26.5GHz: 28dBuV

EUT : AWBC1D
 Test Condition : Tx at channel 40

Frequency (MHz)	Spectrum Analyzer Detector	Antenna Polariz. (H/V)	Preamp. Gain (dB)	Correction Factor (dB/m)	Reading (dBuV)	Corrected Level (dBuV/m)	Limit @ 3 m (dBuV/m)	Margin (dB)	Ant. high (cm)	Turn Table angle (degree)
4860.000	PK	V	36.07	37.77	44.78	46.48	54.00	-7.52	141.00	343.00
4860.000	PK	H	36.07	37.77	43.25	44.95	54.00	-9.05	127.00	223.00

Remark:

1. Correction Factor = Antenna Factor + Cable Loss
2. Corrected Level = Reading + Correction Factor – Preamp. Gain
3. The frequency measured ranges from 1GHz to 25GHz. The data value listed above which is higher than the noise floor, the others please refer to noise floor level.

Noise floor level is:

For PK:

- 1GHz-3GHz: 20dBuV
- 3GHz-14GHz: 27dBuV
- 14GHz-26.5GHz: 39dBuV

For AV:

- 1GHz-3GHz: 10dBuV
- 3GHz-14GHz: 16dBuV
- 14GHz-26.5GHz: 28dBuV

EUT : AWBC1D
 Test Condition : Tx at channel 79

Frequency (MHz)	Spectrum Analyzer Detector	Antenna Polariz. (H/V)	Preamp. Gain (dB)	Correction Factor (dB/m)	Reading (dBuV)	Corrected Level (dBuV/m)	Limit @ 3 m (dBuV/m)	Margin (dB)	Ant. high (cm)	Turn Table angle (degree)
4950.000	PK	V	36.07	37.77	48.22	49.92	54.00	-4.08	130.00	30.00
4950.000	PK	H	36.07	37.77	49.81	51.51	54.00	-2.49	191.00	126.00

Remark:

1. Correction Factor = Antenna Factor + Cable Loss
2. Corrected Level = Reading + Correction Factor – Preamp. Gain
3. The frequency measured ranges from 1GHz to 25GHz. The data value listed above which is higher than the noise floor, the others please refer to noise floor level.

Noise floor level is :

For PK:

- 1GHz-3GHz: 20dBuV
- 3GHz-14GHz: 27dBuV
- 14GHz-26.5GHz: 39dBuV

For AV:

- 1GHz-3GHz: 10dBuV
- 3GHz-14GHz: 16dBuV
- 14GHz-26.5GHz: 28dBuV

9. Emission on the band edge §FCC 15.247(C)

In any 100kHz bandwidth outside the frequency band in which the spread spectrum intentional radiator is operating, the radio frequency power that is produced by the intentional radiator shall be at least 20 dB below that in the 100 KHz bandwidth within the band that contains the highest level of the desired power, based on either an RF conducted or a radiated measurement.

Please see the plot below.

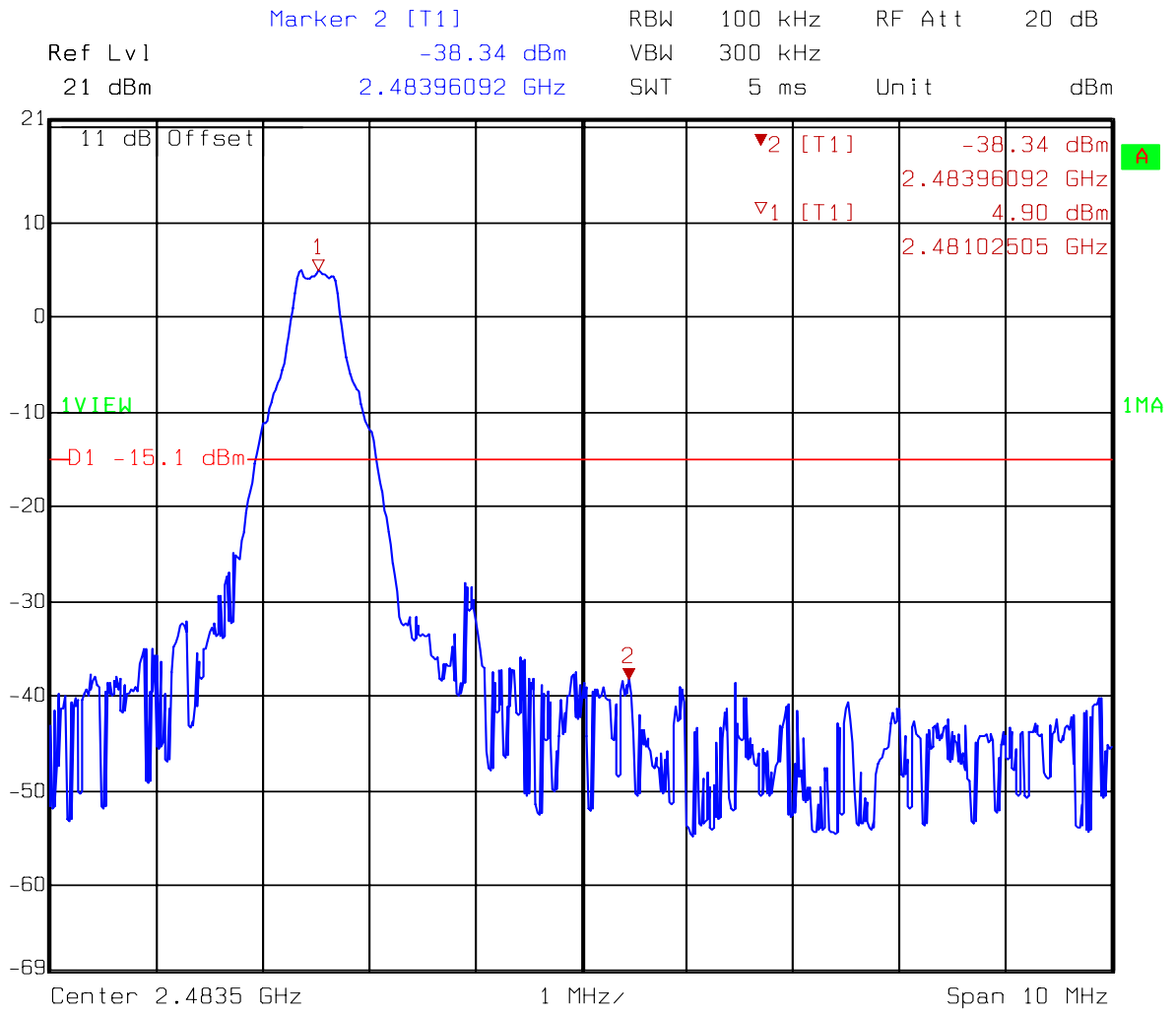

Comment A: Band-edge test at highest channel
Date: 28.SEP.2005 17:19:40

9.2 Band-edge (Radiated method)

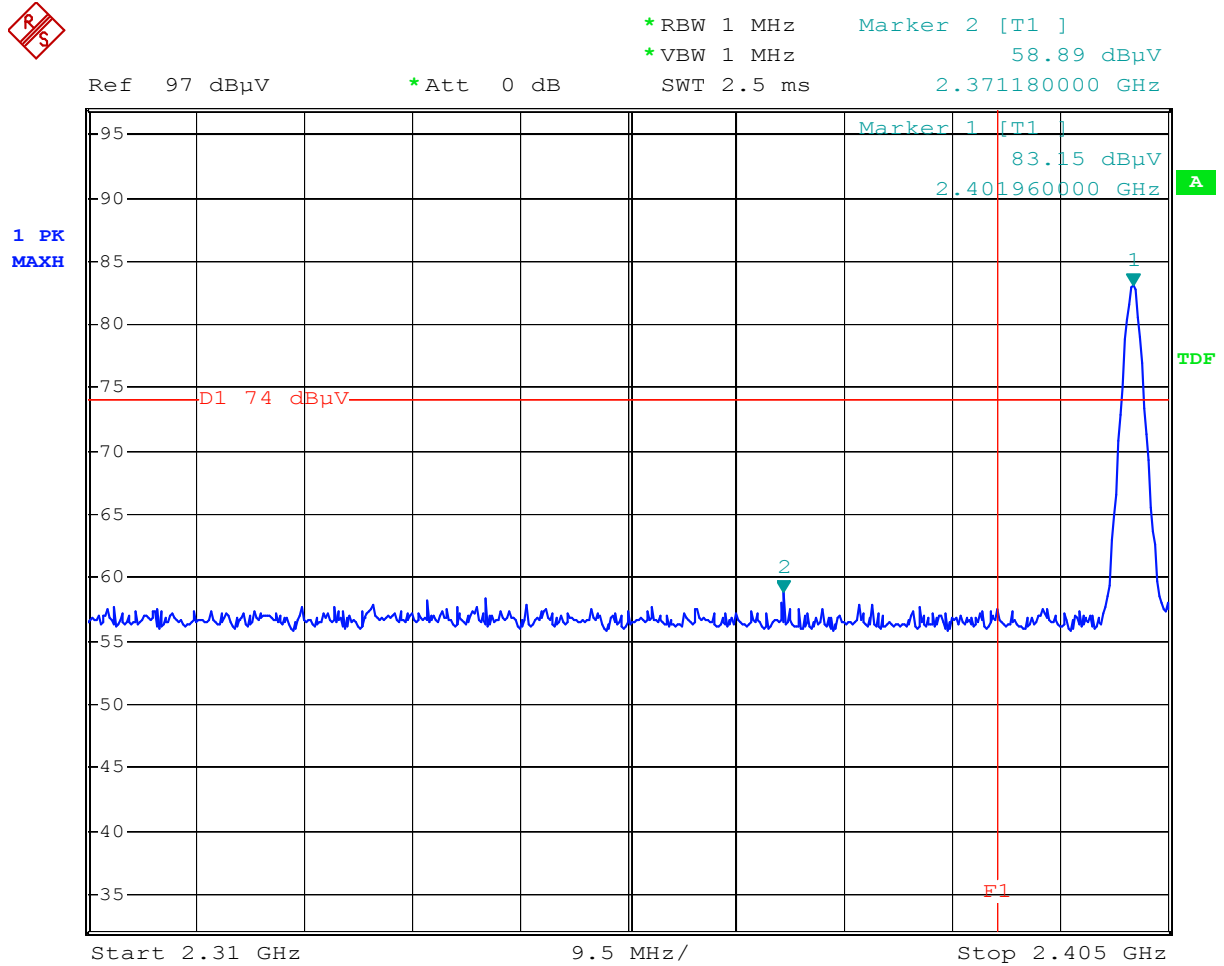

Comment: Band-edge at low channel
 Comment: PK detector F1=2390MHz
 Date: 12.OCT.2005 17:42:44

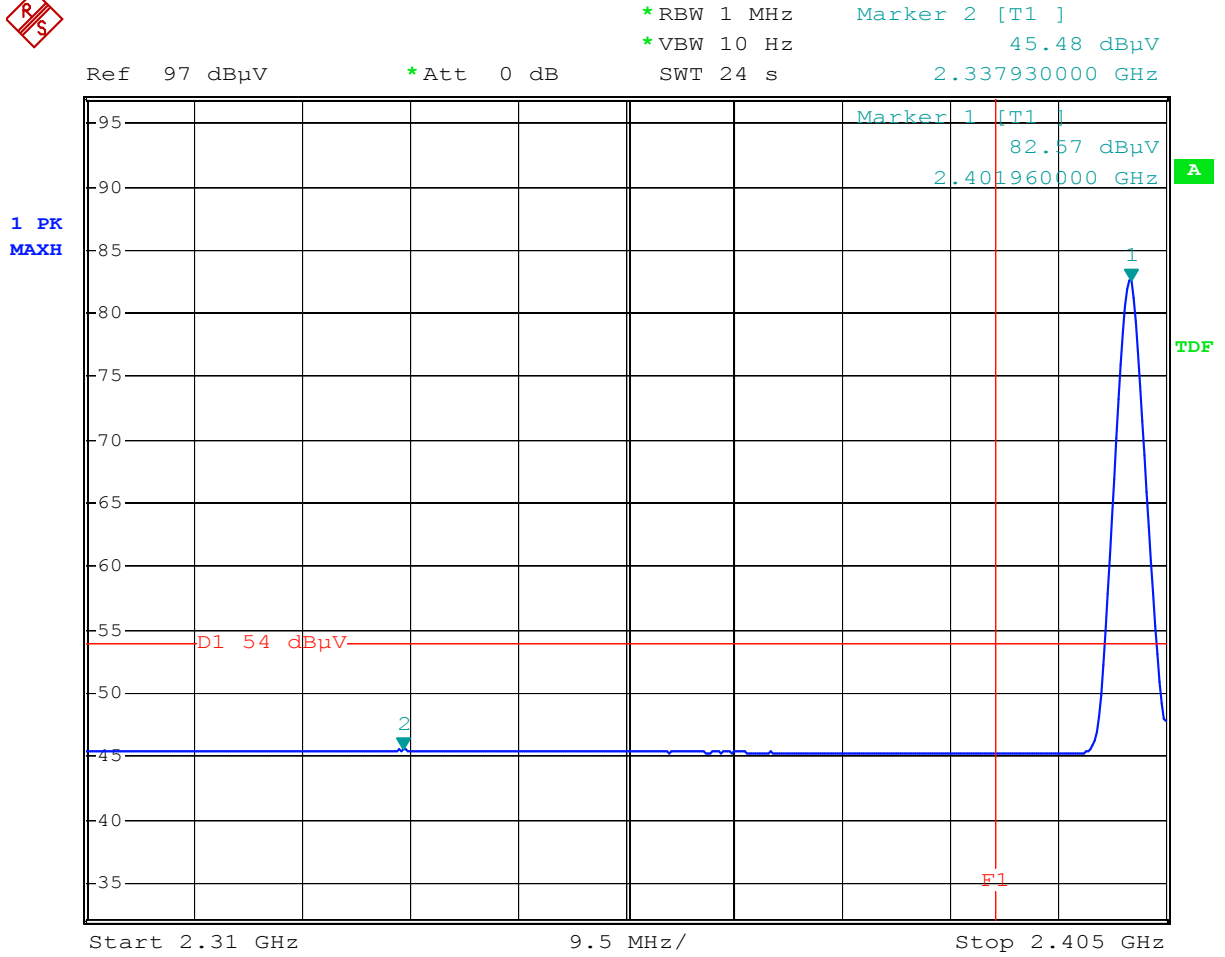

Comment: Band-edge at low channel
 Comment: AV. detector F1=2390MHz
 Date: 12.OCT.2005 17:44:24

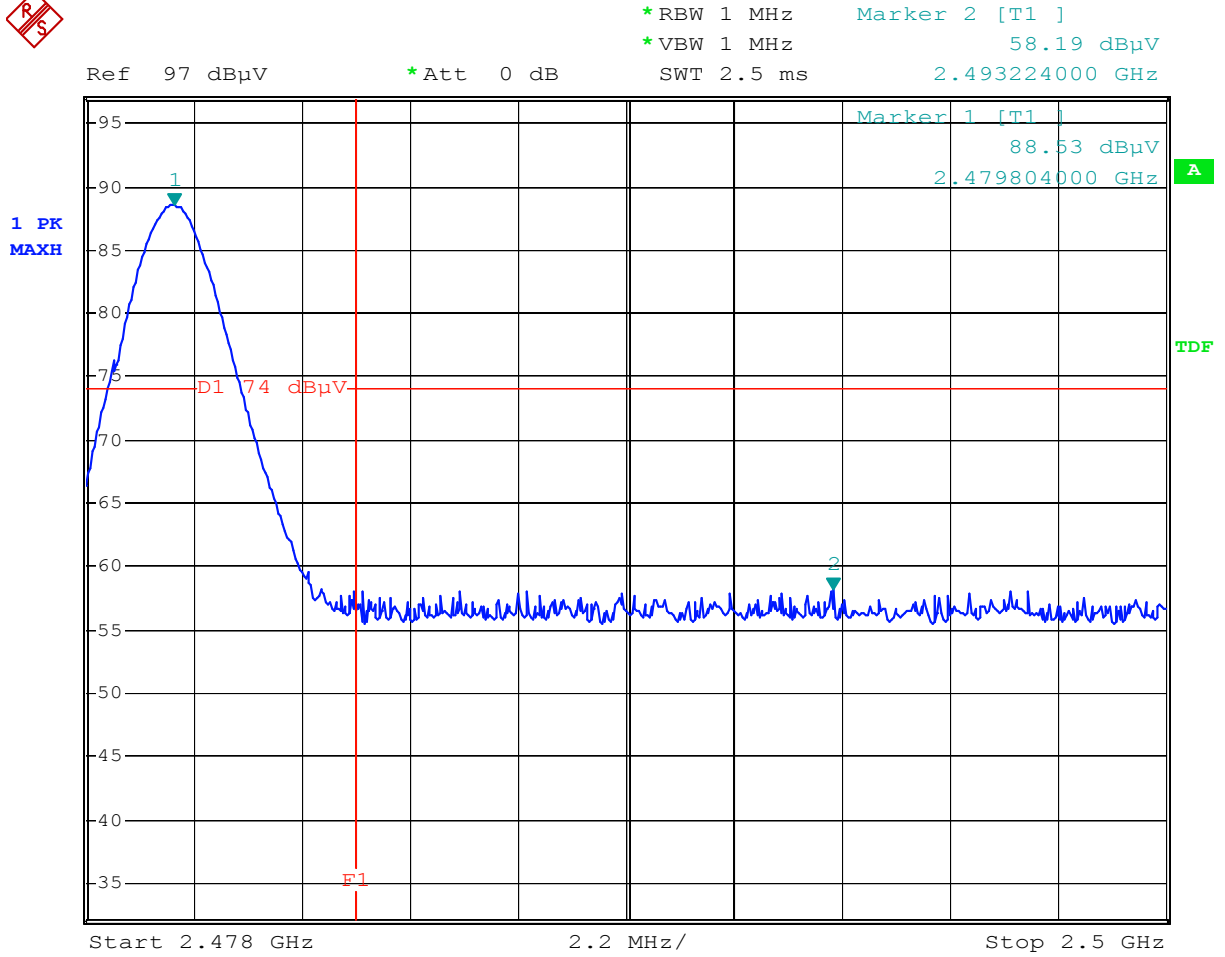

Comment: Band-edge at high channel
 Comment: PK. detector F1=2483.5MHz
 Date: 12.OCT.2005 17:51:08

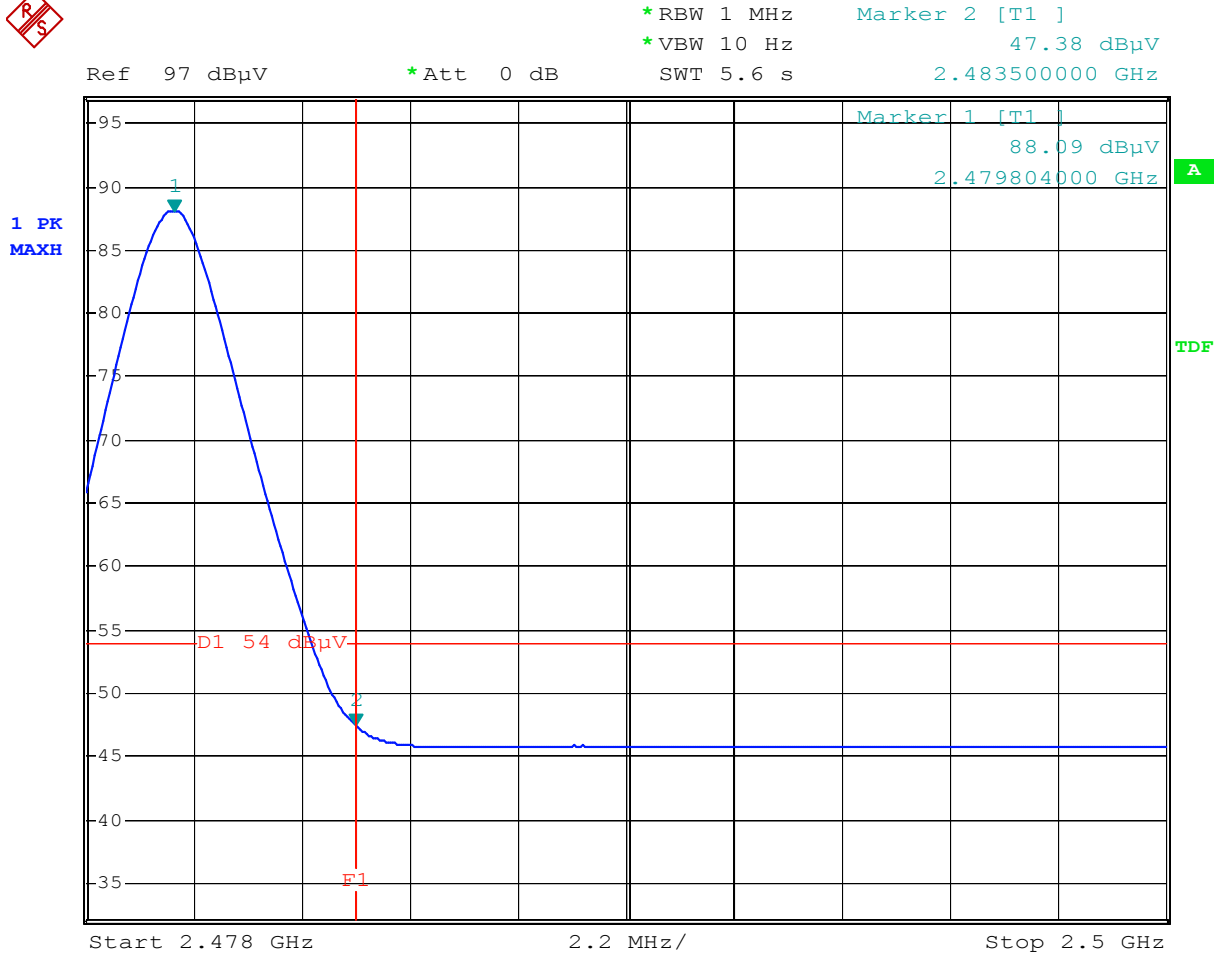

Comment: Band-edge at high channel
 Comment: AV. detector F1=2483.5MHz
 Date: 12.OCT.2005 17:50:16

10. Power Line Conducted Emission test §FCC 15.207

10.1 Operating environment

Temperature:	25	°C
Relative Humidity:	60	%
Atmospheric Pressure	1023	hPa

10.2 Test setup & procedure

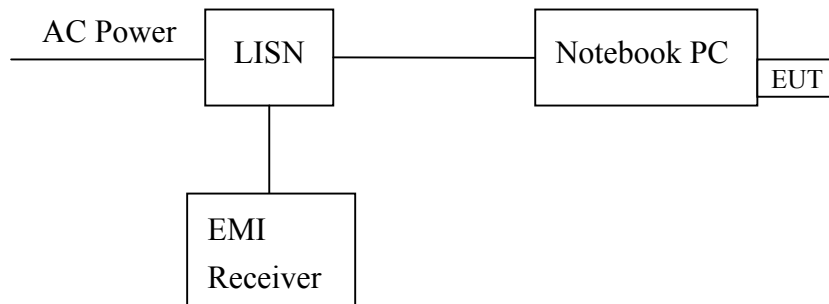

The EUT are connected to the main power through a line impedance stabilization network (LISN). This provides a 50 ohm/50uH coupling impedance for the measuring equipment. The peripheral devices are also connected to the main power through a LISN that provides a 50ohm/50uH coupling impedance with 50ohm termination.

Both sides (Line and Neutral) of AC line are checked for maximum conducted interference. In order to find the maximum emission, the relative positions of equipment and all of the interface cables must be changed according to ANSI C63.4/2003 on conducted measurement. The bandwidth of the field strength meter (R & S Test Receiver ESCS 30) is set at 9kHz.

The EUT configuration please refer to the “Conducted set-up photo.pdf”.

10.3 Emission limit

Freq. (MHz)	Conducted Limit (dBuV)	
	Q.P.	Ave.
0.15~0.50	66 – 56*	56 – 46*
0.50~5.00	56	46
5.00~30.0	60	50

*Decreases with the logarithm of the frequency.

10.4 Uncertainty of Conducted Emission

Expanded uncertainty (k=2) of conducted emission measurement is ± 2.6 dB.

10.5 Power Line Conducted Emission test data

Phase : Line
 EUT : 35170
 Test Condition : Hopping mode

Frequency (MHz)	Corr. Factor (dB)	Level Qp (dBuV)	Limit Qp (dBuV)	Level AV (dBuV)	Limit Av (dBuV)	Margin (dB)	
						Qp	Av
0.156	0.10	51.73	65.67	34.43	55.67	-13.94	-21.24
0.206	0.10	45.66	63.35	26.57	53.35	-17.69	-26.78
0.260	0.10	39.80	61.43	20.80	51.43	-21.63	-30.63
0.315	0.10	36.34	59.85	21.09	49.85	-23.51	-28.76
9.682	0.39	31.74	60.00	26.77	50.00	-28.26	-23.23
15.248	0.70	31.60	60.00	27.26	50.00	-28.40	-22.74

Remark:

1. Correction Factor (dB) = LISN Factor (dB) + Cable Loss (dB)
2. Margin (dB) = Level (dBuV) - Limit (dBuV)

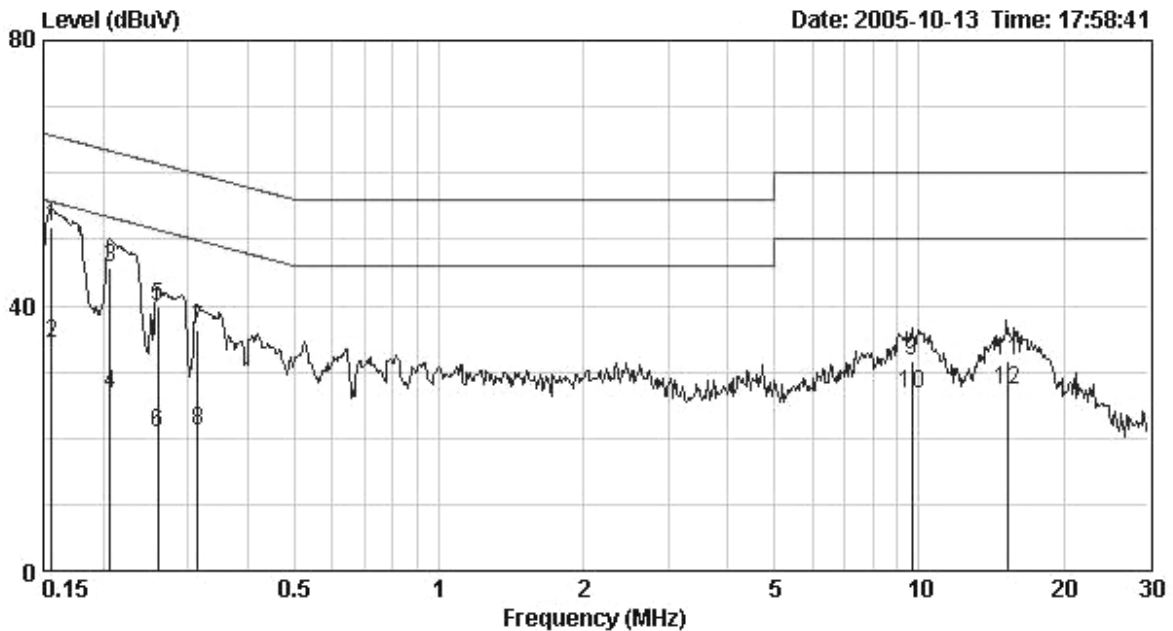

Phase : Neutral
 EUT : 35170
 Test Condition : Hopping mode

Frequency (MHz)	Corr. Factor (dB)	Level Qp (dBuV)	Limit Qp (dBuV)	Level AV (dBuV)	Limit Av (dBuV)	Margin (dB)	
						Qp	Av
0.157	0.10	51.29	65.60	33.52	55.60	-14.31	-22.08
0.201	0.10	34.13	63.55	17.27	53.55	-29.42	-36.28
0.260	0.10	39.10	61.43	21.81	51.43	-22.33	-29.62
0.312	0.10	35.92	59.91	17.92	49.91	-23.99	-31.99
10.156	0.21	32.81	60.00	27.47	50.00	-27.19	-22.53
15.370	0.41	31.97	60.00	26.58	50.00	-28.03	-23.42

Remark:

1. Correction Factor (dB)= LISN Factor (dB) + Cable Loss (dB)
2. Margin (dB) = Level (dBuV) – Limit (dBuV)

