

## APPROVAL SHEET

Customer Name: HP

Date: 11/30/2010

Doc. Version: A01

<b>Customer P/N</b>	5184-6684
<b>WNC P/N</b>	60RNAA0P.G03
<b>Description</b>	RNAA-H1
<b>Version</b>	A03

Wistron NeWeb Corporation  
No. 20, Park Avenue II,  
Hsinchu Science Park  
Hsinchu 308, Taiwan, R.O.C.  
TEL: +886-3-666-7799  
FAX: +886-3-666-7711  
<http://www.wneweb.com>

啓碁科技股份有限公司  
新竹市 308 科學園區  
區二路 20 號  
電話：(03) 666-7799  
傳真：(03) 666-7711

## RNAA-H1 Antenna spec

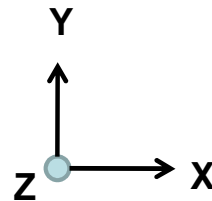
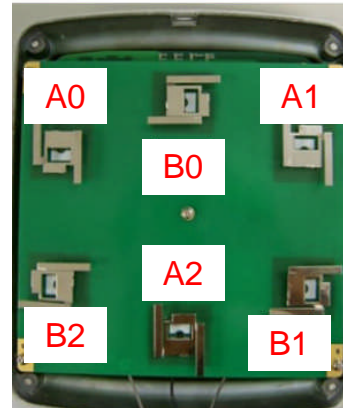

Item	Specification
HP Product Number	5184-6684
WNC Part Number	60RNAA0P.G03
VSWR max	2.0:1
Polarization	Linear
Impedance (Ohms)	50
Front to back ratio (dB)	N/A
Dimensions in. (cm)	6.18 x 6.18 (15.7 x 15.7)
Height in. (cm)	0.39 (1)
Mounting Style	Ceiling mount
RF Connector	U.FL
Storage Temperature (min/max)	-40° to +65°C
Operating Temperature (min/max)	-30° to +55°C

**Note: The antenna performance test was conducted with system PCBA and housing**

Frequency (MHz)	Maximum Peak Gain (dBi)	Minimum Efficiency (%)
2400-2500	5.41dBi	51%
4900-5900	7.02dBi	55%

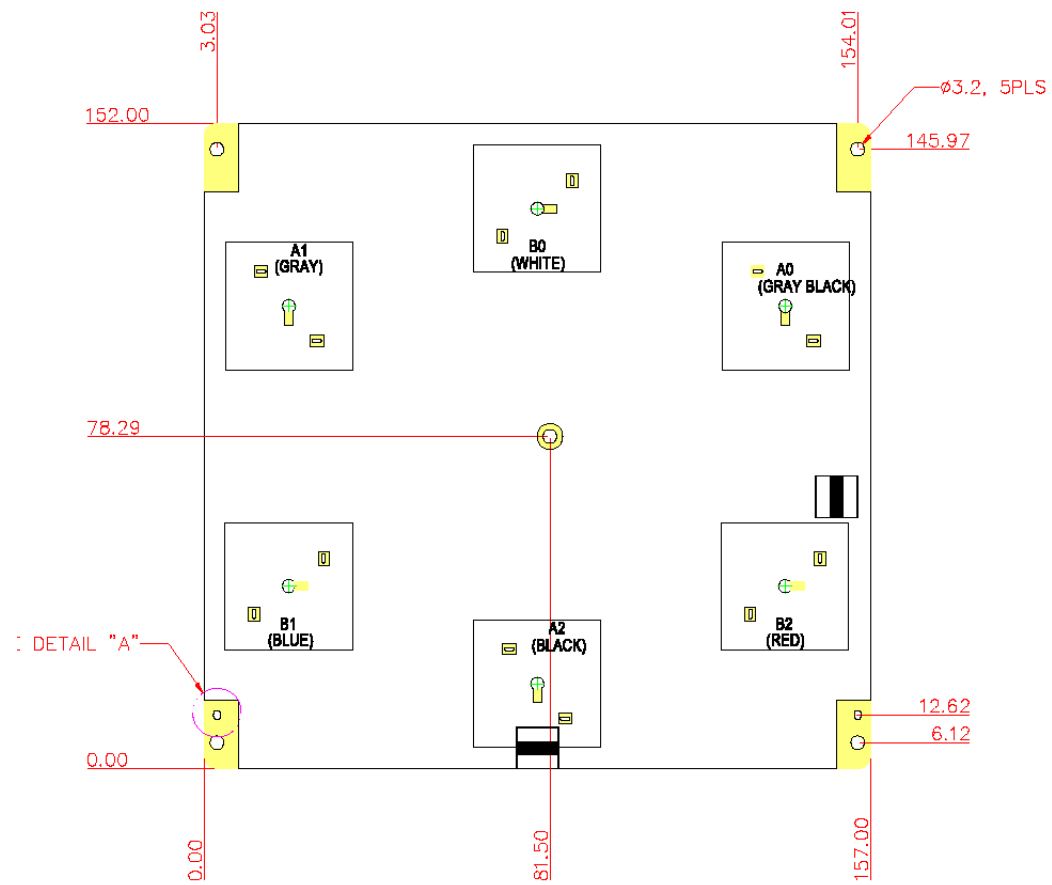

FRONT SIDE

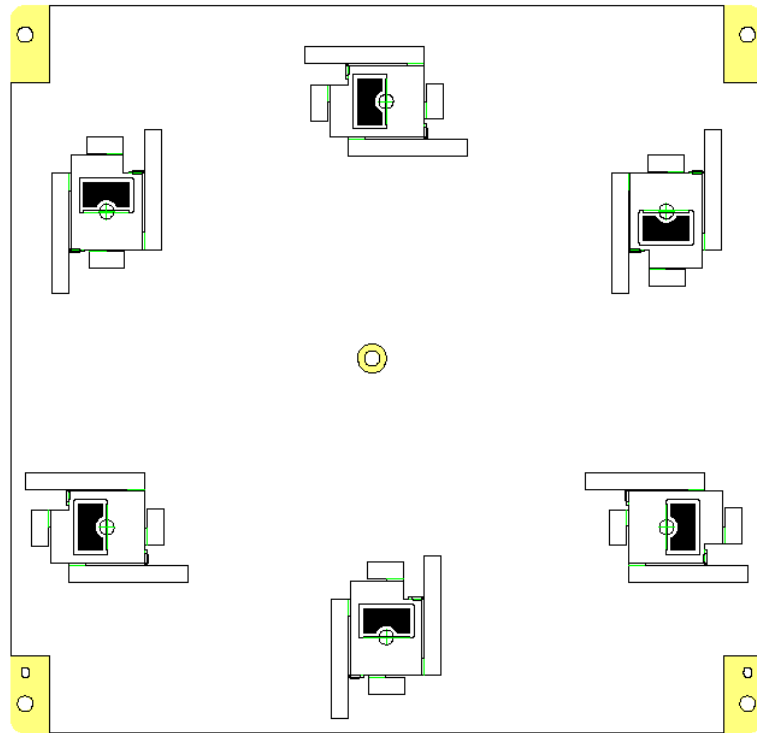

BACK\_SIDE

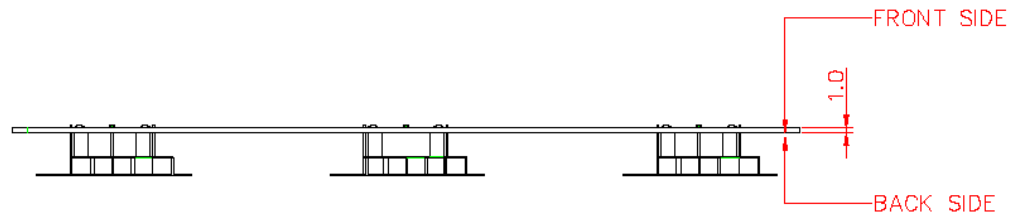

**Cable Diameter: 1.37 mm**

**Cable Length:**

**A0:200 mm**

**A1:210 mm**

**A2:110 mm**

**B0:180 mm**

**B1:210 mm**

**B2:135 mm**

# Ant A0

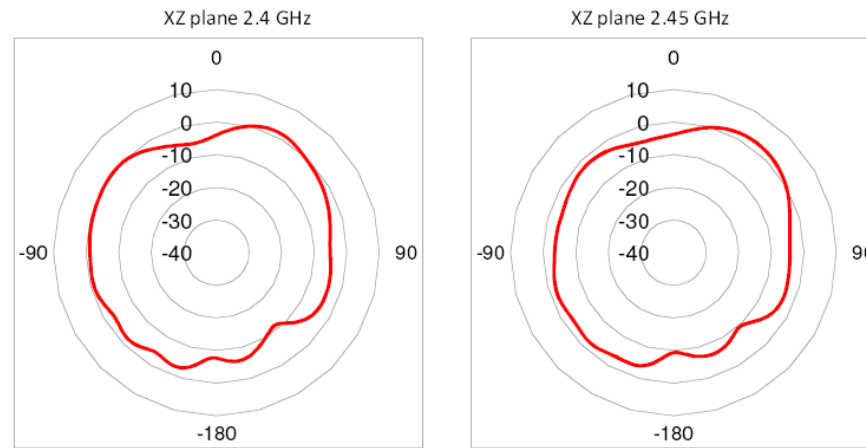

# Ant A0

XZ plane 4.9 GHz

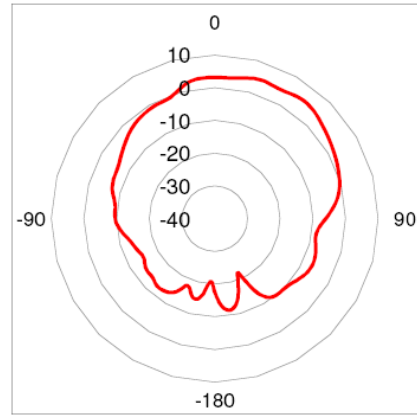

XZ plane 5.5 GHz

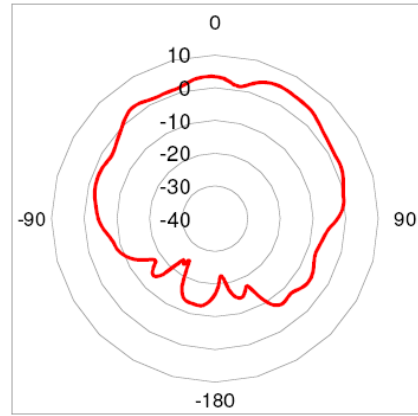

XZ plane 5.85 GHz

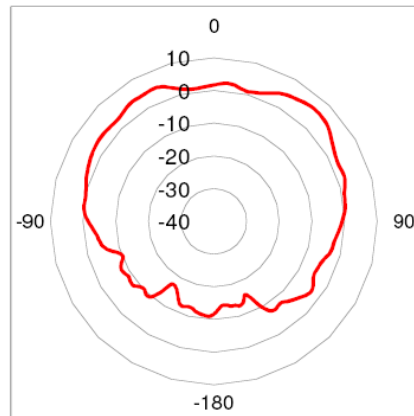



Ant A0

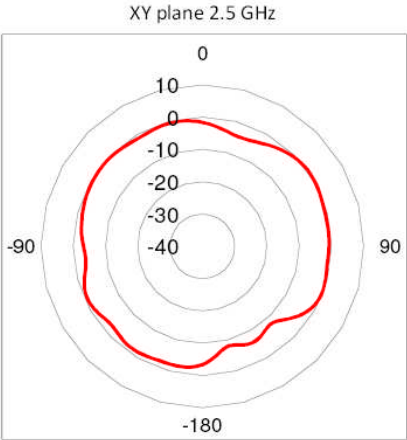
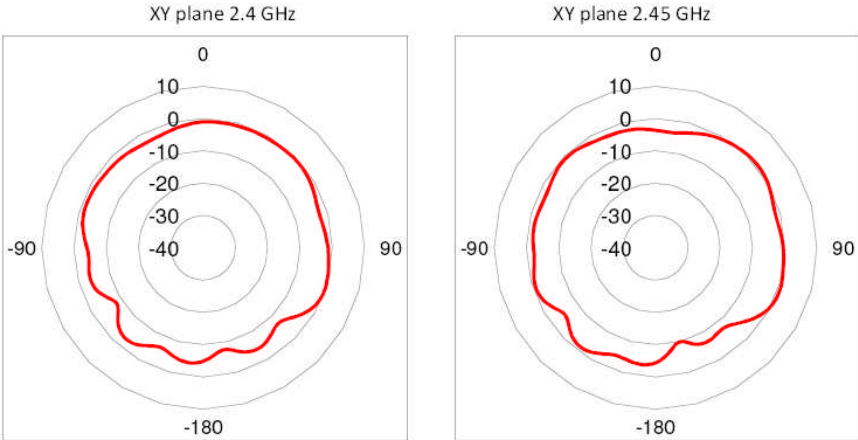

# Ant A0

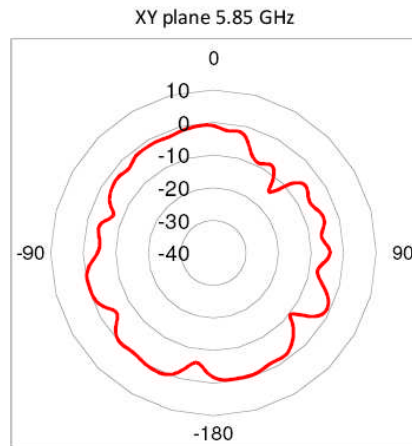
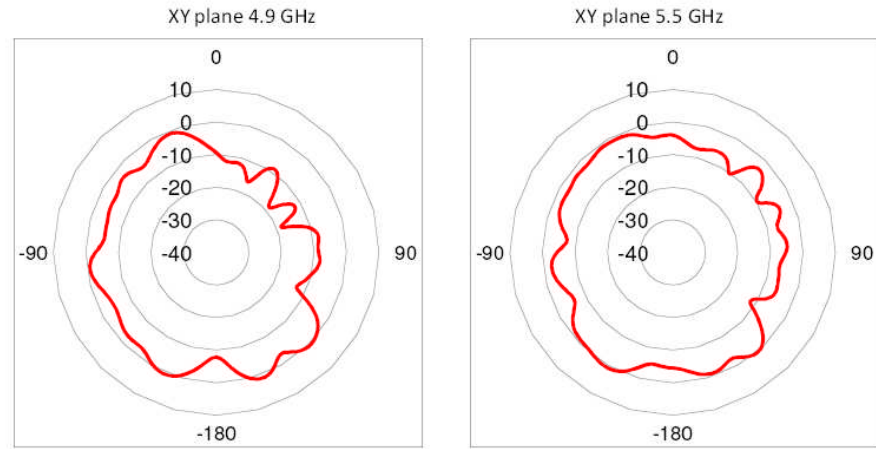

# Ant A1

XZ plane 2.4 GHz

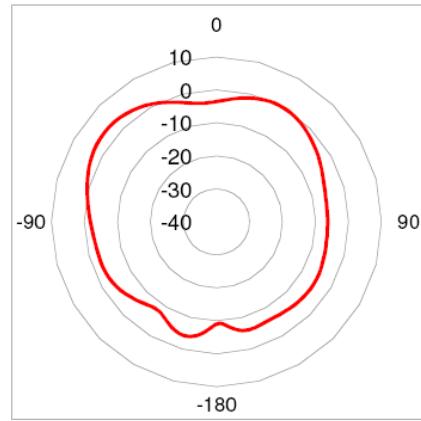

XZ plane 2.45 GHz

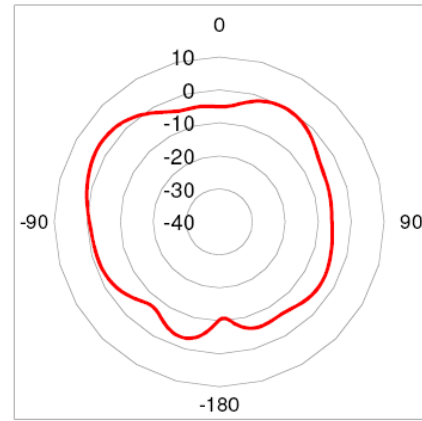

XZ plane 2.5 GHz

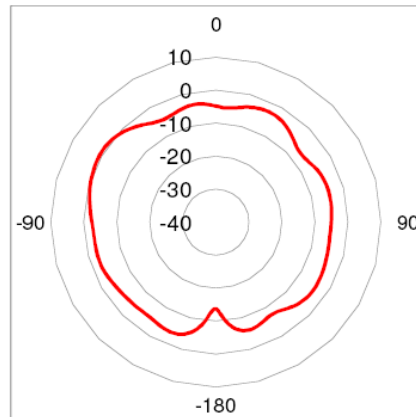

Ant A1

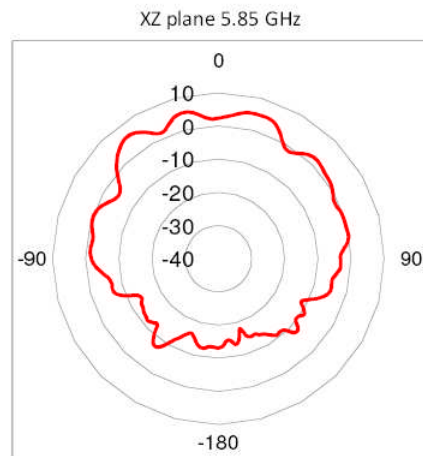
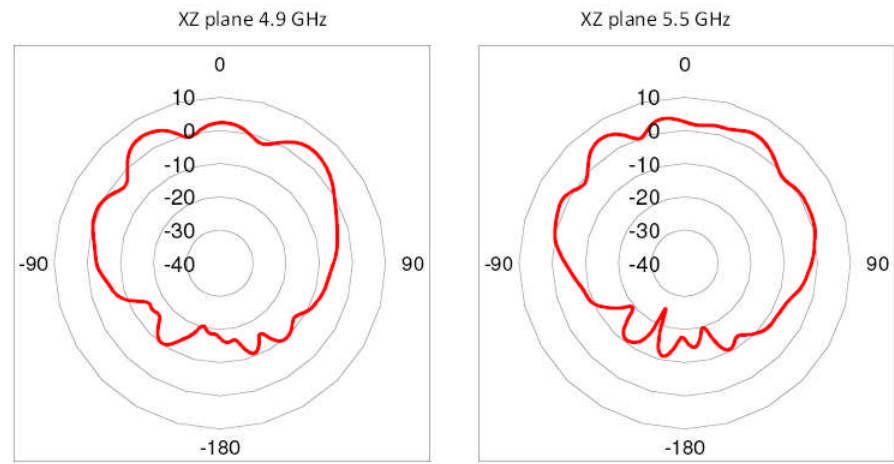

# Ant A1

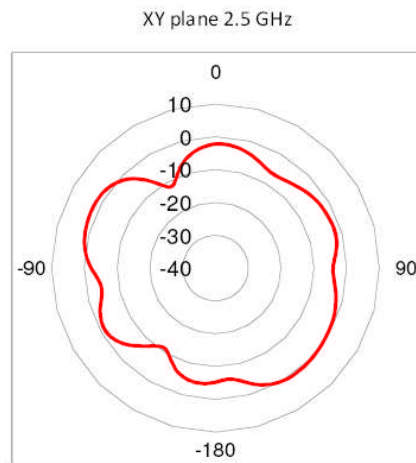
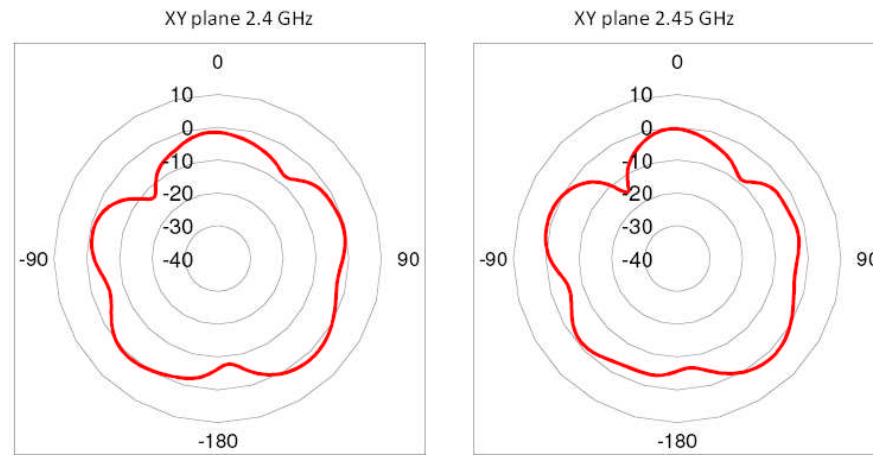

# Ant A1

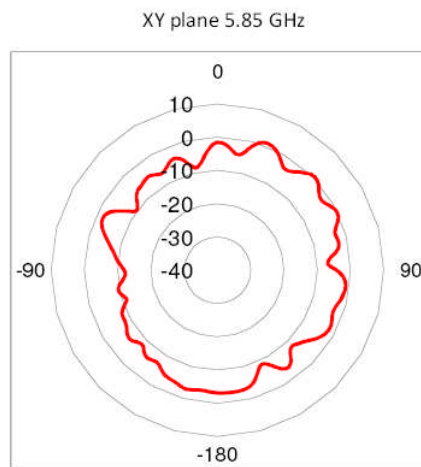
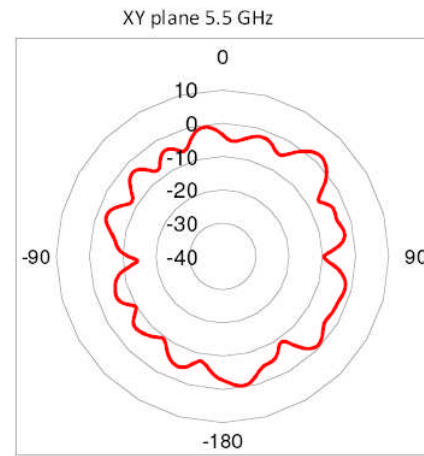
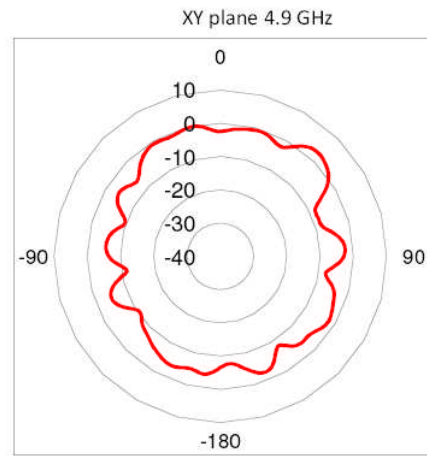

# Ant A2

XZ plane 2.4 GHz

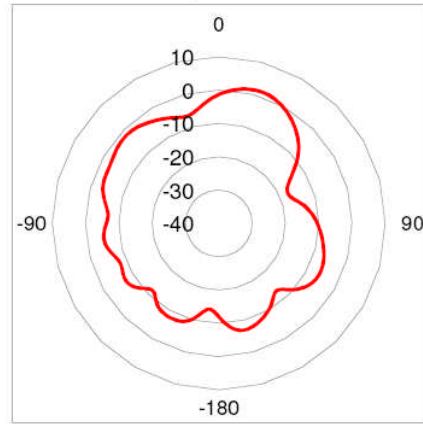

XZ plane 2.45 GHz

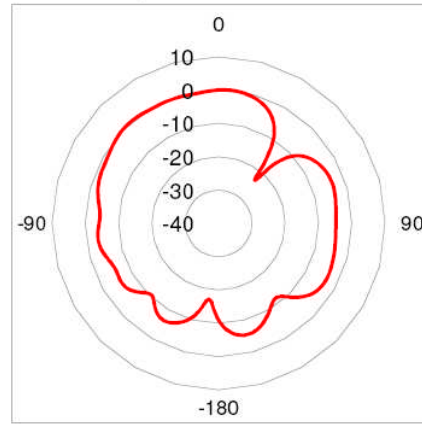

XZ plane 2.5 GHz

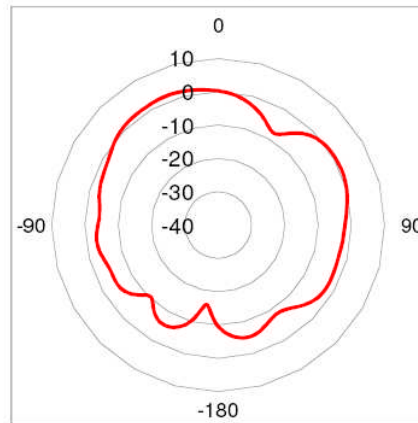

# Ant A2

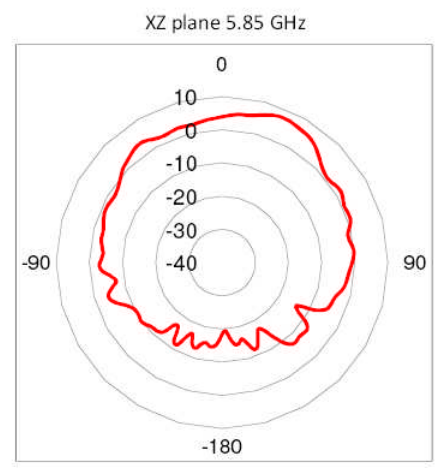
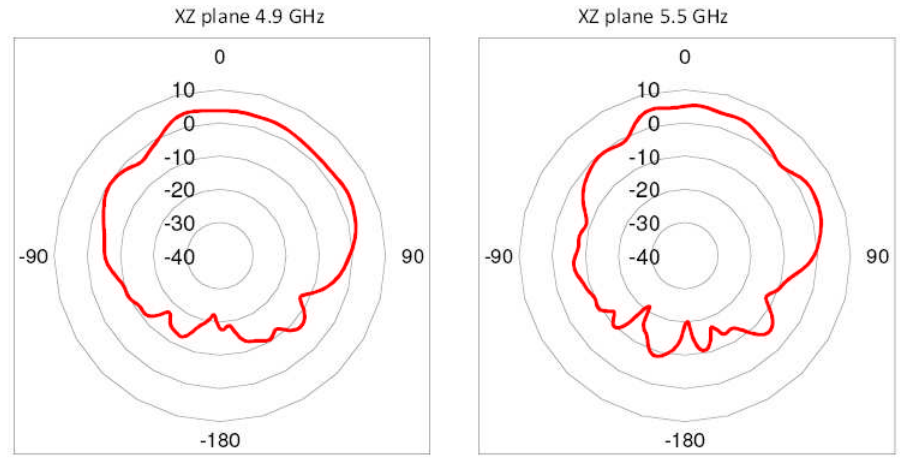



# Ant A2

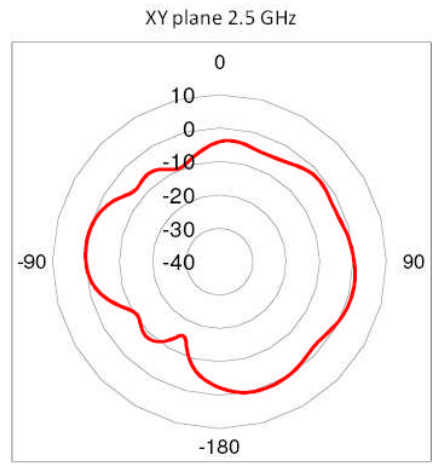
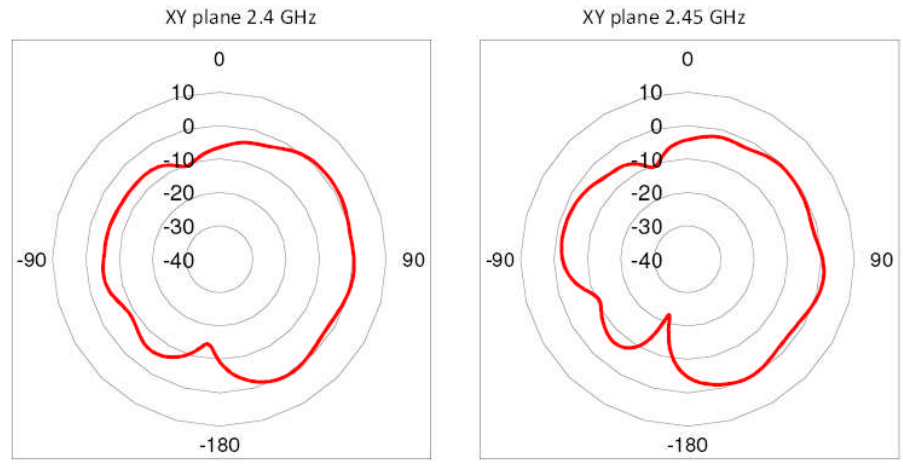

# Ant A2

XY plane 4.9 GHz

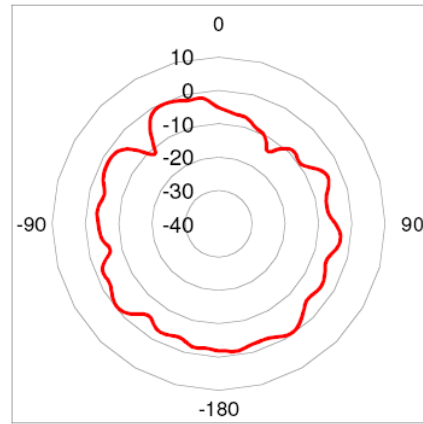

XY plane 5.5 GHz

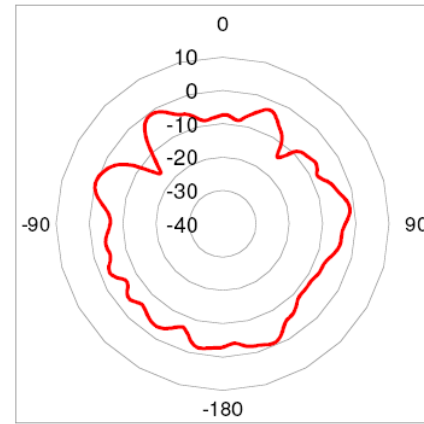

XY plane 5.85 GHz

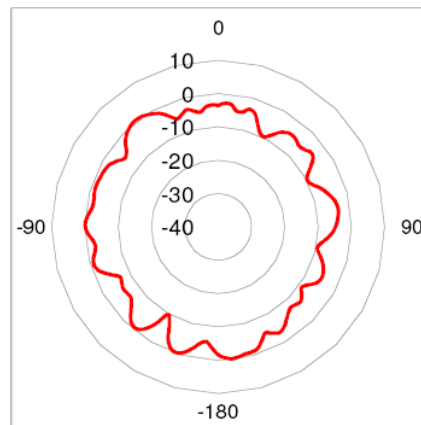

# Ant B0

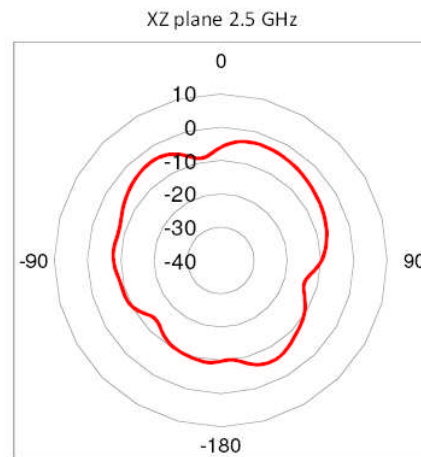
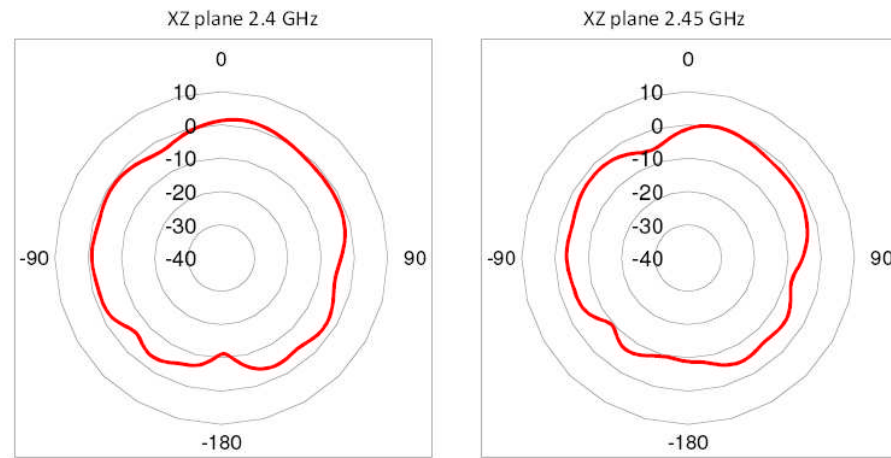

# Ant B0

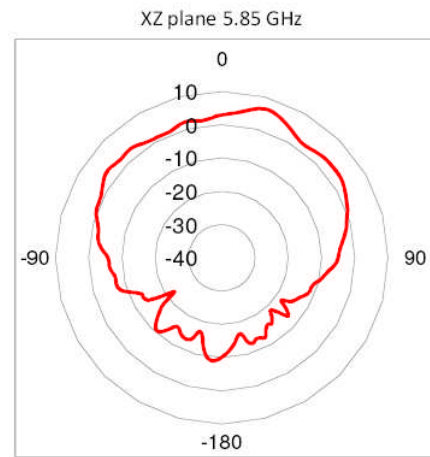
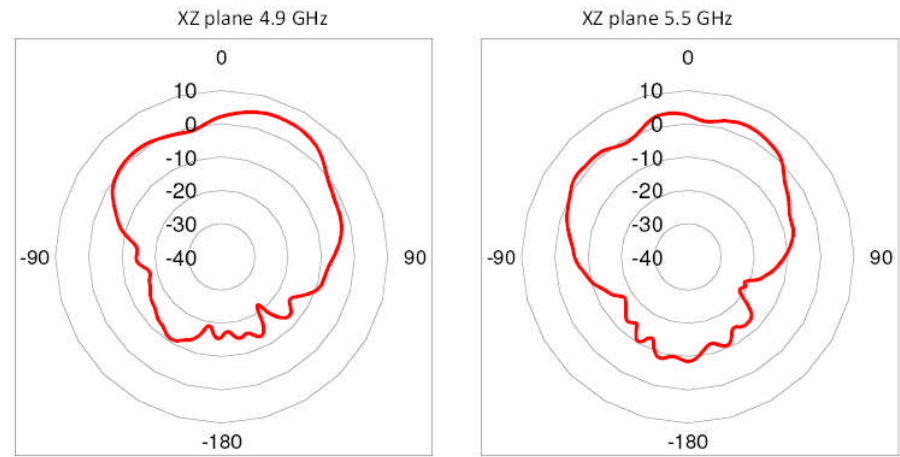

# Ant B0

XY plane 2.4 GHz

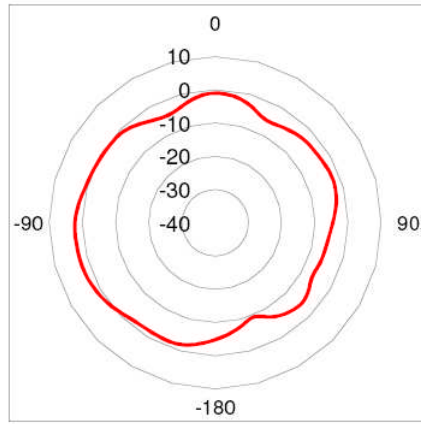

XY plane 2.45 GHz

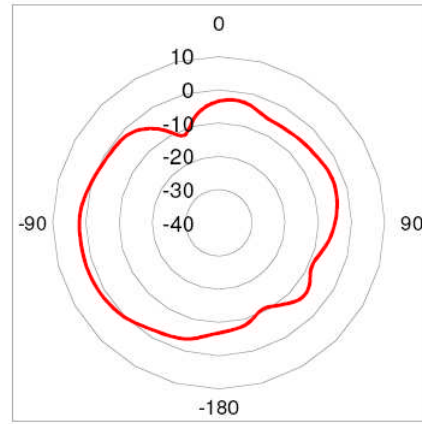

XY plane 2.5 GHz

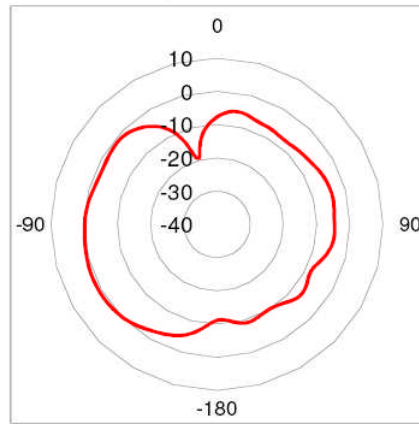

# Ant B0

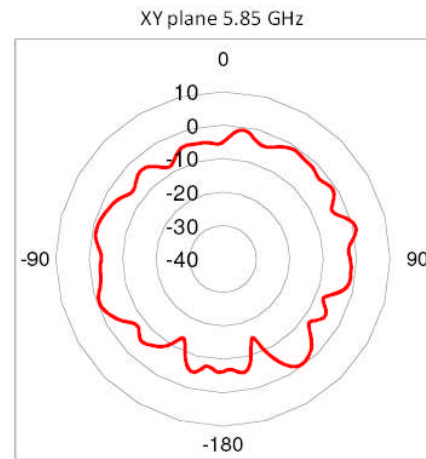
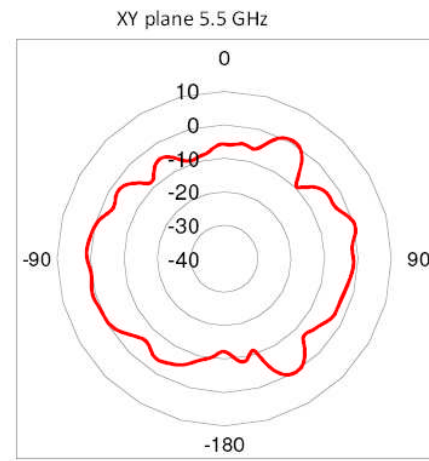
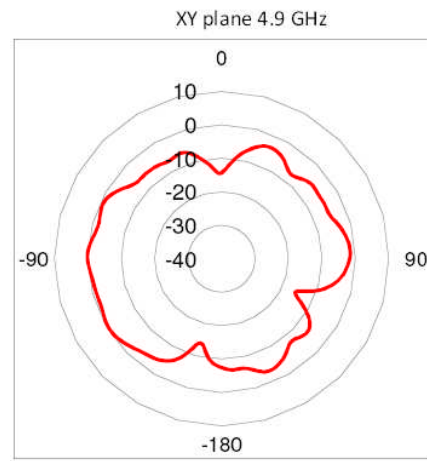

# Ant B1

XZ plane 2.4 GHz

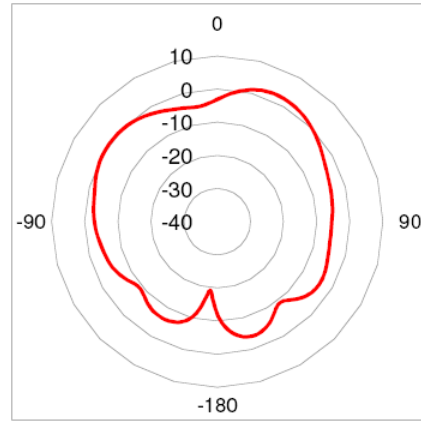

XZ plane 2.45 GHz

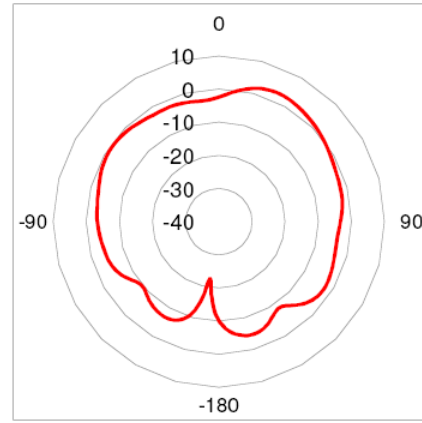

XZ plane 2.5 GHz

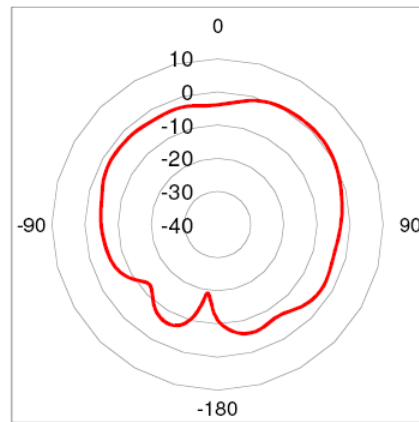

# Ant B1

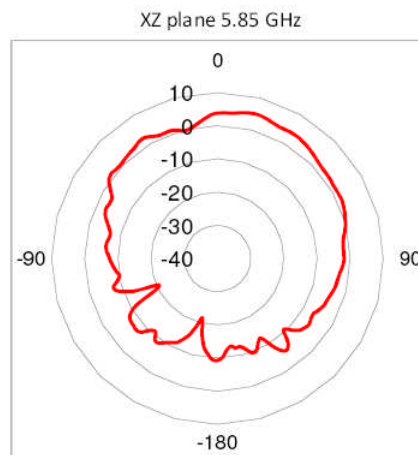
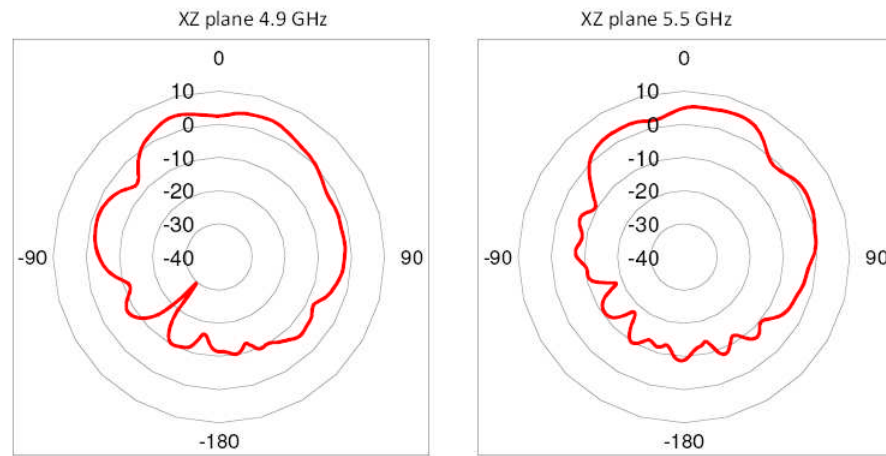



# Ant B1

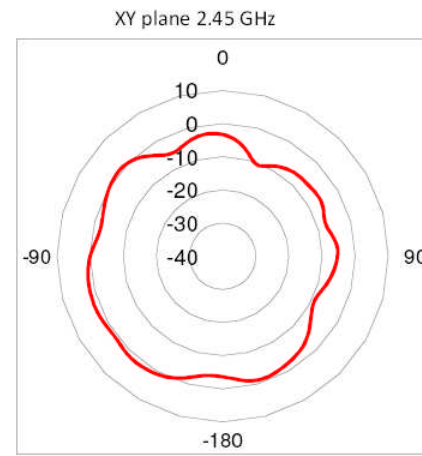
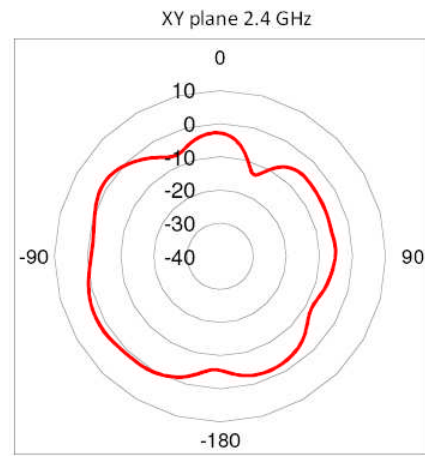

# Ant B1

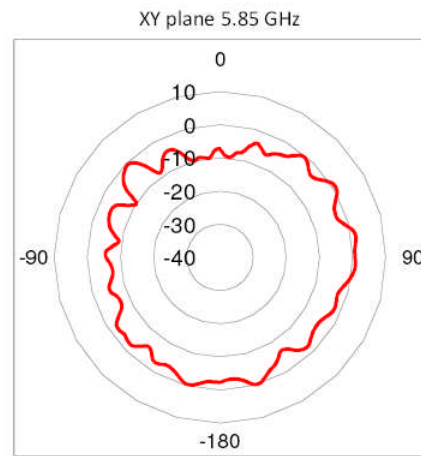
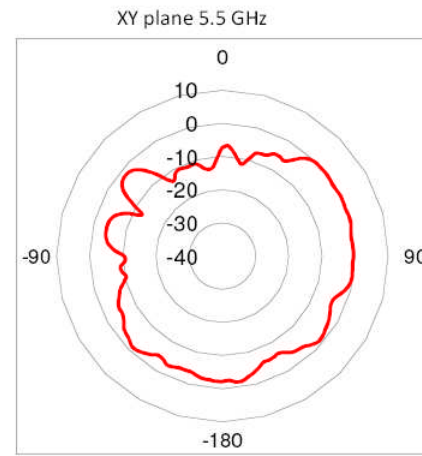
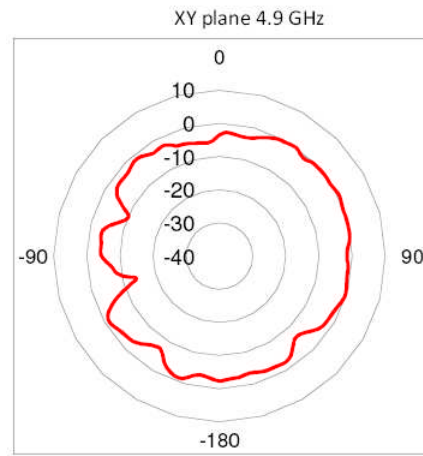

# Ant B2

XZ plane 2.4 GHz

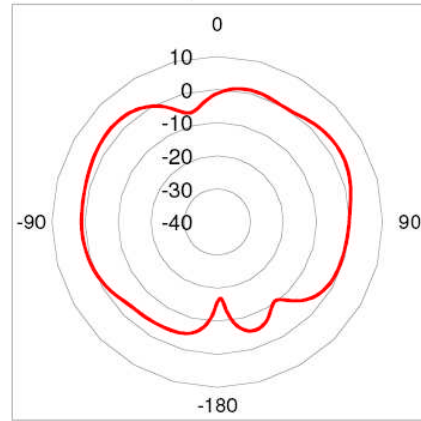

XZ plane 2.45 GHz

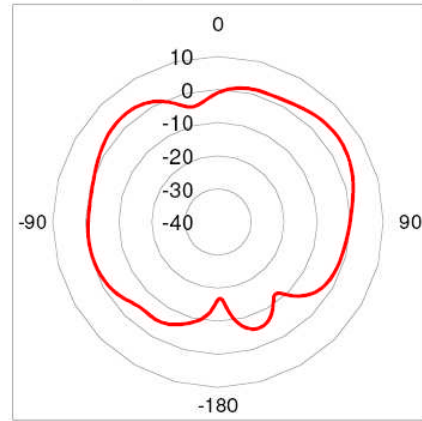

XZ plane 2.5 GHz

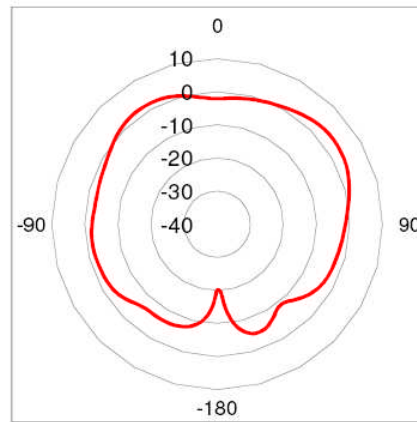

# Ant B2

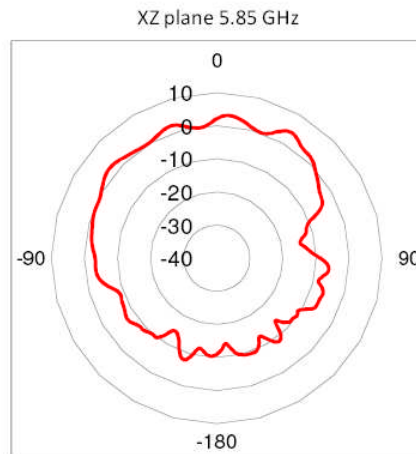
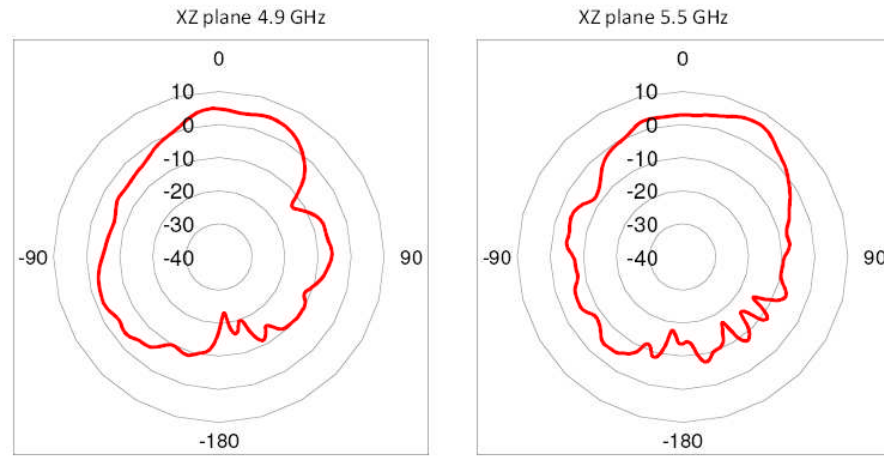

# Ant B2

XY plane 2.4 GHz

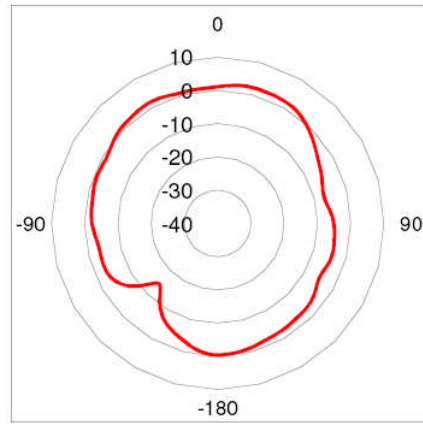

XY plane 2.45 GHz

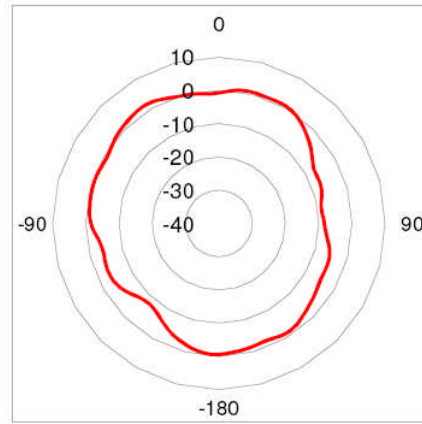

XY plane 2.5 GHz

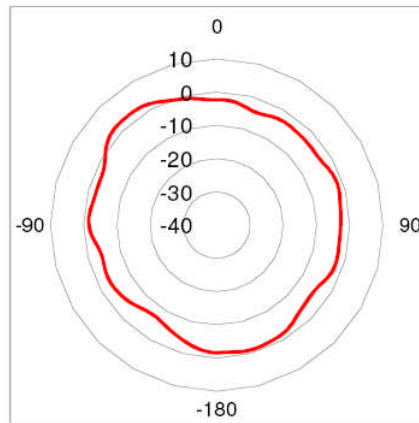

# Ant B2

