



ENGLISH

GV60 Bidirectional Control System for use with The Puck and Symax® Handsets together with myfire® App

Installation and Operating Instructions

GV60 Bidirectional Control System for use with The Puck and Symax® Handsets together with myfire® App

Installation and Operating Instructions

APPLICATION AND COMPONENTS

Application	3
Components	3

GV60 – GAS COMBINATION CONTROL

Technical Data	4
Mounting Position	5
Gas Connections	5
Perform Pressure Test	5
Wiring	6
Thermocouple Circuit	6
Ignition Cable	6
Receiver	6
V Module	7
Knob Settings	8
Adjustment	8
Final Check	9
Manual Operation	9
Turn off Gas to Appliance	10
Automatic turn down to pilot	10
Automatic Shut off	10

TOUCHPAD/WALL SWITCH	11
SWITCH PANEL	11

SYMAX HANDSET

Technical Data	12
Synchronization Receiver/Symax Handset	12
General Notes	12

8-BUTTON OPERATION	13
Setting Fahrenheit or Celsius	13
Setting the Time	13
Child Proof	13
Manual Mode	14
Designated Low Fire and High Fire	14
Countdown Timer	14
Modes of Operation	15
Thermostatic Mode	15
Program Mode	15
2nd Burner Feature	16
Eco Mode	16

myfire App	16
10-BUTTON OPERATION	17
Setting Fahrenheit or Celsius	17
Setting the Time	17
Child Proof	17
Manual Mode	18
Designated Low Fire and High Fire	18
Countdown Timer	18
Modes of Operation	19
Thermostatic Mode	19
Program Mode	19
2nd Burner Feature	20
Eco Mode	20
Circulating Fan Operation	20
Light/Dimmer Operation	21
myfire App	21

THE PUCK HANDSET

Technical Data	22
Synchronization Receiver/ The Puck Handset	22
Modes of Operation	22

MYFIRE WI-FI BOX (B6R-W2...)

Technical Data	23
Modes of Operation	23

MYFIRE WI-FI BOX (B6R-W2...) RGB LEDS AND LED DRIVER

Technical Data	24
Requirements for external LED Driver	24

MYFIRE APP SETUP

App setup	25
-----------------	----

WIRING DIAGRAMS

Basic	26
Fan, Light/Dimmer, 2nd Burner Feature	27
2nd Thermocouple	28
Receiver for Power Flue Control	29
Myfire App setup	30

IMPORTANT SAFETY INFORMATION

▲ WARNING

Read these instructions carefully and completely before installing or operating. Failure to follow them could result in a fire or explosion causing property damage, personal injury, or loss of life. Service and installation must be performed by a trained/experienced service technician.

WHAT TO DO IF YOU SMELL GAS

- Do NOT operate any appliance.
- Do NOT touch any electrical switch; do NOT use any phone in your building.
- Immediately evacuate the area and contact the gas supplier. Follow the gas supplier's instructions.
- If you cannot reach the gas supplier, call the fire department.

Installation and service must be performed by a qualified installer, service agency, or the gas supplier. Installation shall conform with local codes, or in the absence of local codes, in accordance with the National Fuel Gas Code ANSI Z223.1/NFPA 54 or the IFGC or CSA B149.1. All piping and tubing must comply with local codes and ordinances.

Use only your hand to push in or turn the gas control knobs. Never use tools. If a knob will not push in or turn by hand, do not try to repair it. Call a qualified service technician. Force or attempted repair can result in a fire or explosion.

Do NOT use a product if you suspect it has been subjected to high temperatures, damaged, tampered with, or taken apart. Do NOT use a product if you suspect it has been under water or that liquid has seeped into the product. Any of these incidents can cause leakage or other damage that may affect proper operation and cause potentially dangerous combustion problems.

Do NOT store or use gasoline or other flammable vapors and liquids in the vicinity of this control or other appliances.

▲ WARNING

ELECTRIC SHOCK HAZARD

- Read these instructions carefully. Failure to follow them could result in property damage, personal injury, or loss of life.
- This control must be electrically wired and operated in accordance with all codes and local regulations. Service and installation must be performed by a trained, experienced service technician.
- Do NOT use the control if you suspect it may be damaged.

GENERAL INSTALLATION INFORMATION

NOTICE

It is the responsibility of the OEM to consider the following:

- The location of the GV60 system components will significantly affect the radio signal strength.
- The type of materials (e.g. sheet metal) used in the construction of the gas fireplace will significantly effect the radio signal strength.
- Operate the system with a dedicated mains power supply and/or batteries.
- Do not use near household electrical wiring and/or magnetic fields.
- Other transmitters using the same signal will negatively affect the radio signal strength.
- Adjustment of the on-board antenna on the receiver can improve signal strength.
- Do not store or locate the GV60 system components in a hot, cold, or humid environment.
- Make sure that the end user can access the receiver for a reset or to synchronize a new transmitter.

APPLICATION AND COMPONENTS

APPLICATION

GV60 is a battery-powered electronic remote ignition and control system for gas appliances with pilot burners and ODS systems.

COMPONENTS



Figure 1: Handsets



Figure 2: Operation

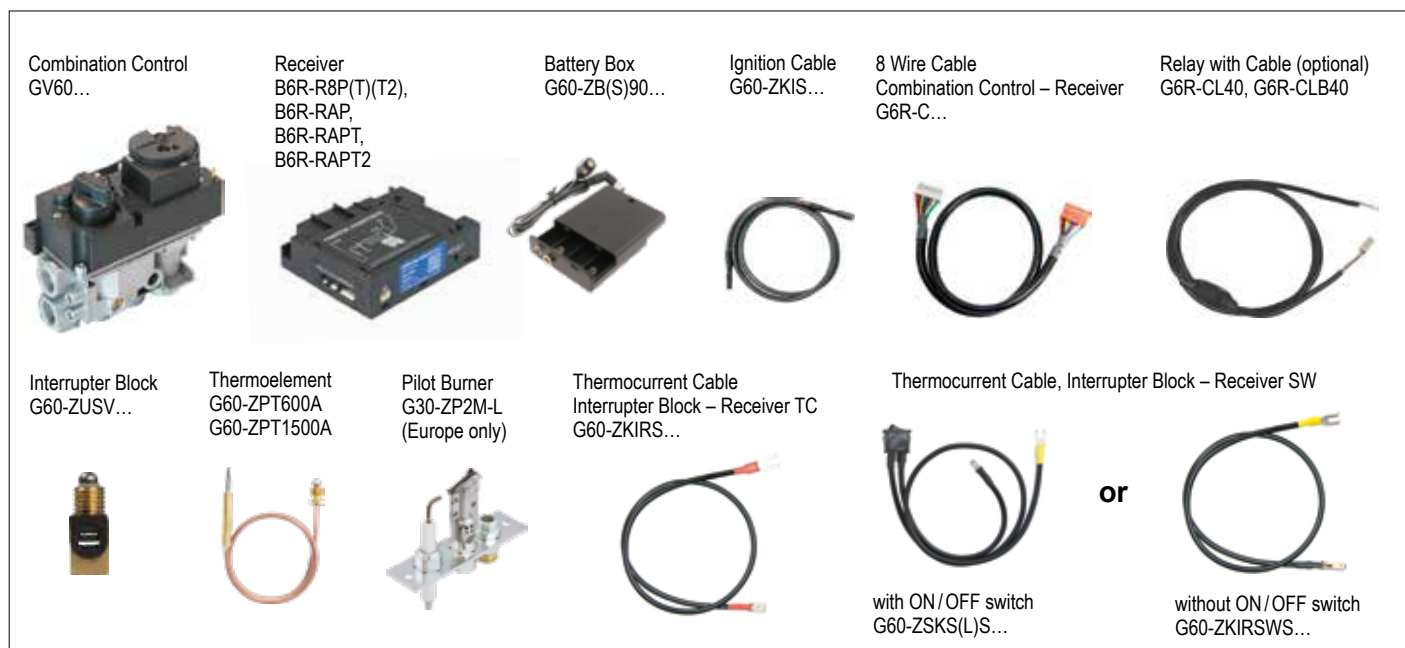

Figure 3: Basic



Figure 4: Additional Function (Latching Solenoid, Fan, Light/Dimmer)



Figure 5: Mains Adapter

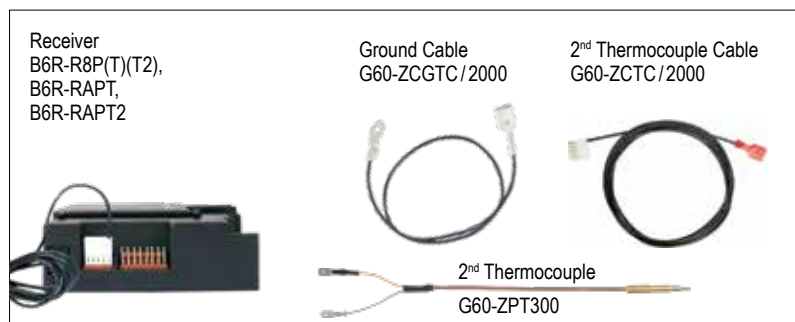

Figure 6: 2nd Thermocouple Option

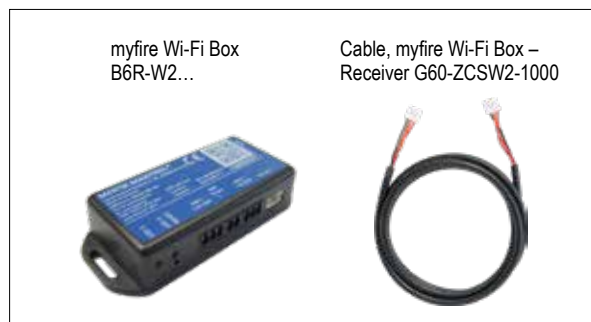

Figure 7: myfire App setup

ENGLISH

GV60 – GAS COMBINATION CONTROL

TECHNICAL DATA

APPROVALS

- CSA: Multifunctional gas control according to ANSI Z21.78 6.20 and ANSI Z21.20 6.20 for U.S. & Canada
 CE: Gas Appliances Regulation 2016/426/EU and DIN EN 298, DIN EN 126, DIN EN 13611, 2014/53/EU (RED)

FUELS

- CSA: Suitable for natural, manufactured, mixed gases, liquefied petroleum gases, and LP gas-air mixtures.
 CE: Suitable for use with gases of EN 437 gas family 1, 2 and 3.

PRESSURE DROP/CAPACITY

- CSA: @ 1" w.c. at 65,000 BTU/hr for 0.65 s.g. natural gas
 CE: 2.5 mbar (0.25 kPa) at 1.2 m³/hour

RANGE OF REGULATION

- CSA: 10,000 to 85,000 BTU/hr
 CE: Class C according EN 88

REGULATOR ADJUSTMENT

- CSA: 3" w.c. to 5" w.c.; 8" w.c. to 12" w.c.
 Convertible Regulator: 3 to 4.5" NG/8.5 to 11.5" LP
 CE + CSA: 3" w.c. to 12" w.c. (7.5 to 30 mbar)
 CE: 5 to 40 mbar (0.5 to 4 kPa)

MAXIMUM INLET PRESSURE

- CSA: ½ psi (14" w.c.)
 CE: 50 mbar (5 kPa)

MAIN GAS CONNECTION

- CSA: ¾ NPT (ANSI/ASME B1.20.1)
 CE: Rp ¾ (ISO 7-1/EN 10226-1), compression fittings for 8 mm, 10 mm or 12 mm tube

PILOT GAS CONNECTION

- CSA: 7/16-24 UNS for ¼" or ⅜" tubing
 CE: M10x1 for 4 mm or 6 mm tubing

INLET AND OUTLET CONNECTION

Side or Bottom

MAXIMUM ALLOWED TORQUE

- INLET, OUTLET, LATCHING SOLENOID ¾"
- CSA: 280 inch-pounds
- CE: 35 Nm
- LATCHING SOLENOID 8 mm tube
- CE: 20 Nm
- PILOT GAS CONNECTION
- CSA: 100 inch-pounds
- CE: 15 Nm

THERMOCOUPLE/INTERRUPTER BLOCK

11/32-32 UNS, M10x1, M9x1, M8x1

AMBIENT TEMPERATURE RANGE

- CSA: Combination Control: 32 °F to 176 °F
 Latching Solenoid Valve: 32 °F to 176 °F
 Misc. cables: 221 °F
 Relay with Cable: 158 °F
 CE: Combination Control: 0 °C to 80 °C
 Latching Solenoid Valve: 0 °C to 80 °C
 Misc. cables: 105 °C
 Relay with Cable: 70 °C

GENERAL RADIO FREQUENCY INFORMATION

Amendment: This device complies with Part 15 of the FCC Rules. The device contains licence-exempt transmitter(s)/receiver(s) that comply with Innovation, Science and Economic Development Canada's licence-exempt RSS(s). Operation is subject to the following two conditions:

- (1) This device may not cause interference.
- (2) This device must accept any interference, including interference that may cause undesired operation of the device. Changes or modifications not expressly approved by the party responsible for compliance could void the user's authority to operate the equipment. To satisfy ISED exposure requirements a separation distance of 20 cm or more should be maintained between the antenna of this device and persons during operation. To ensure compliance, operations at closer distances than this are not recommended.

NOTE: This equipment has been tested and found to comply with the limits for a Class B digital device, pursuant to part 15 of the FCC Rules. These limits are designed to provide reasonable protection against harmful interference in a residential installation. This equipment generates, uses and can radiate radio frequency energy and, if not installed and used in accordance with the instructions, may cause harmful interference to radio communications. However, there is no guarantee that interference will not occur in a particular installation. If this equipment does cause harmful interference to radio or television reception, which can be determined by turning the equipment off and on, the user is encouraged to try to correct the interference by one or more of the following measures:

- Reorient or relocate the receiving antenna.
- Increase the separation between the equipment and receiver.
- Connect the equipment into an outlet on a circuit different from that to which the receiver is connected.
- Consult the dealer or an experienced radio/TV technician for help.

Compliant with the EU-Radio Equipment Directive 2014/53/EU (RED).

▲ WARNING

It is the appliance manufacturer's responsibility to determine GV60's suitability for a specific application.

▲ WARNING

Do NOT remove screws from the gas valve. Do NOT adjust and/or alter any components marked with tamper indicating paint. Motor knob is not to be removed.

▲ WARNING

1. Turn off gas supply at the appliance service valve before starting installation, and perform a Gas Leak Test after the installation is complete.
2. Install the sediment trap or filter (where required) in the gas supply line to prevent contamination of the gas valve (see figure 8, page 5).
3. Use only your hand to push in or turn the gas control knobs. Never use tools. If a knob will not push in or turn by hand, do not try to repair it. Call a qualified service technician. Force or attempted repair will void warranty and can result in a fire or explosion.

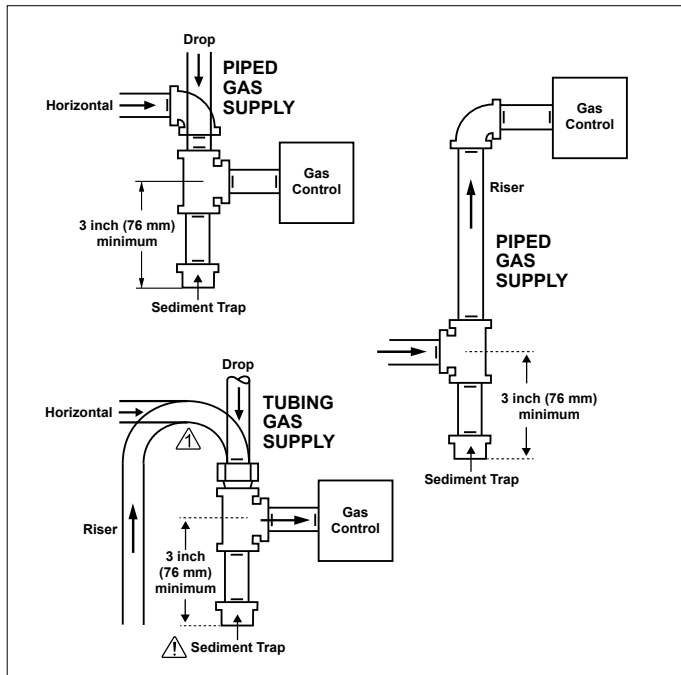

Figure 8: Sediment Trap (where required)

MOUNTING POSITION

In upright position, gas control knobs are on top of the valve. Valve may be mounted 0° to 90° any direction (including vertical) from the upright position. Valve must NOT be mounted upside down.

LOCATION

Locate the combination gas valve where it is not exposed to steam cleaning, high humidity, dripping water, corrosive chemicals, dust or grease accumulation, or excessive heat.

To assure proper operation, follow these guidelines:

- Locate combination gas valve in a well-ventilated area.
- Mount combination gas valve high enough to avoid exposure to flooding or splashing water.
- Make sure the ambient temperature does not exceed the ambient temperature ratings for each component.

▲ WARNING

GV60 standard version is suitable for indoor use only.

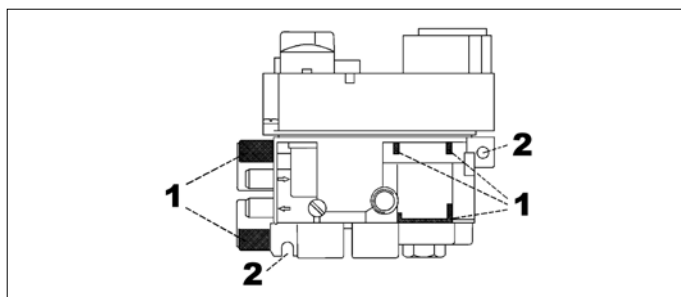

Figure 9: 1 = Clamp Areas, 2 = Mounting Points

GAS CONNECTIONS

▲ WARNING

Fire or Explosion Hazard. Can cause property damage, severe injury, or death. Do NOT bend tubing at gas valve connection point after compression fitting has been tightened. This can result in a gas leak at the connection.

▲ WARNING

Use new, properly reamed pipe free from metal or material chips. When tubing is used, assure that ends are square, deburred and clean. All tubing bends must be smooth and free of distortion.

When threads are tightened, the valve must be held at the designated clamping points (see figure 9, page 5).

▲ WARNING

Do not overtighten connections. Overtightening can damage the control body resulting in a leak or a control malfunction. (see MAXIMUM ALLOWED TORQUE, see page 4)

Main Gas (Tubing Connections)

1. Do not use pipe joint compound. Mertik Maxitrol does NOT recommend the use of Teflon®/PTFE tape.
2. Slip nut and ferrule over tubing.
3. Slide nut and ferrule into place, and insert tubing into inlet/outlet connection until it bottoms. Turn finger tight.
4. Use a wrench to tighten nut about 1 turn beyond finger tight.

Main Gas (Pipe Connections)

1. Mertik Maxitrol does NOT recommend the use of Teflon®/PTFE tape.
2. Pipe to be inserted into the valve must be the proper thread length and to gauge. Thread that is cut too long can cause distortion or malfunction if inserted too deeply. Thread cut too short can cause thread stripping if over-torqued.
3. Apply a moderate amount of approved pipe sealant to the pipe only, leaving the two end threads bare.
4. Connect pipe to valve inlet and outlet.

Pilot Gas (Tubing Connections)

1. Do not use pipe joint compound. Mertik Maxitrol does NOT recommend the use of Teflon®/PTFE tape.
2. Slip fitting over tubing.
3. Insert pilot tubing into pilot outlet until it bottoms. Turn fitting finger tight.
4. Turn with a wrench until you shear off the ferrule. Turn an additional ¾ turn to make a gas tight seal.
5. Connect other end of tubing to pilot burner.

▲ WARNING

The control valve must be in the closed position when the gas supply line is tested for leakage up to 150mbar (15kPa; 2PSI). Above 150mbar (15 kPa; 2PSI) the control valve must be isolated from the gas supply.

PERFORM PRESSURE TEST

1. Check carefully for gas leaks immediately after the valve has been installed and the gas turned on. **Do this before attempting to operate the appliance or other gas burning device.**
2. Using a clean brush, apply an approved leak test solution to the tubing and pipe connections. Bubbles indicate a leak.
3. If no leakage is detected, light the main burner.
4. With the main burner in operation, apply an approved leak test solution to all tubing and pipe connections (including adapters) and the valve inlet and outlet. Bubbles indicate a leak.
5. If a leak is detected, tighten pipe connections (including adapters) according to "Gas Connections" (see page 5).

⚠ WARNING

Do NOT use if leakage is detected. There is a danger of fire or explosion depending on conditions.

WIRING

(see figures 28-32, pages 26-30)

Connect all components according to the appropriate wiring diagram.

- When GV60 components are installed, make sure they are not exposed to dirt, oil, grease or other chemical agents.
- Do not permit foreign particles under plastic cover.
- Place **ON/OFF** switch (if equipped) where it is easily accessible for the user.

NOTICE

Wiring of valve and receiver must be completed before starting ignition. Failure to do so could damage the electronics.

THERMOCOUPLE CIRCUIT

Total resistance of thermocouple circuit should be minimized to ensure proper operation.



Figure 10



Figure 11



Figure 12

NOTICE

The use of the Mertik Maxitrol interrupter block is recommended. Keep connection of interrupter block and thermocouple clean and dry. Avoid excessive bending of the thermocouple tubing during installation (min. 1" radius; 2.5 cm) as this can cause it to fail.

1. Tighten brass interrupter block into valve ¼ turn beyond finger tight. If necessary, an additional ¼ turn is possible.

CAUTION: Further tightening will damage the plastic sleeve in the brass interrupter block and will cause a short in the circuit.

NOTE: Do not over-torque or under-torque the interrupter block to achieve a specific slot alignment.

2. Slide spade connectors into plastic insert (see figure 10, page 6).
3. Slide plastic insert with spade connectors into the brass interrupter block until it snaps (see figure 11, page 6).
4. While holding the interrupter block with a wrench, thread the thermocouple into the female end of the interrupter block ¼ – ½ turn beyond finger tight (see figure 12, page 6).

IGNITION CABLE

AMBIENT TEMPERATURE RANGE

CSA: Ignition Cable: 302 °F
 CE: Ignition Cable: 150 °C

CAUTION: Damage and/or interference will occur to the GV electronic system if the ignition cable (high voltage) is not separated from other GV system wiring.

NOTICE

Do not damage the ignition cable while attaching it to the ignition electrode. When the cable is in place, avoid contact with sharp objects or edges. With cables longer than 900 mm, avoid contact with metal parts, as this could decrease spark.

RECEIVER

AMBIENT TEMPERATURE RANGE

CSA: Receiver without internal batteries: 32 °F to 176 °F
 Receiver with internal batteries: 32 °F to 131 °F
 CE: Receiver without internal batteries: 0 °C to 80 °C
 Receiver with internal batteries: 0 °C to 55 °C

RADIO FREQUENCY

CSA: 918.0MHz for U.S. (FCC), Canada (ISED), New Zealand (RNZ) and Australia (ACMA) (handset, receiver)
 CE: 868.1 MHz for Europe (handset, receiver)
 (see general radio frequency information on page 4.)

RADIATED POWER OUTPUT

CSA: 89.2 µV/m
 CE: -3.5 dBm

POWER CONSUMPTION (STANDBY)

CSA + CE: B6R-R8(A)... : 0.7mW

POWER CONSUMPTION (NOMINAL)

CSA + CE: B6R-R8(A)... : 0.8mW

POWER CONSUMPTION (MOTOR TURN)

CSA + CE: B6R-R8(A)... : 0.25W

POWER CONSUMPTION (IGNITION)

CSA + CE: B6R-R8(A)... : 3.0W

POWER SUPPLY

Receiver: 4 x 1.5V "AA" (quality alkaline recommended)
 An AC mains adapter may be used instead of batteries.

NOTICE

Only the Mertik Maxitrol AC mains adapter (see figure 5, page 3) or one preapproved by Mertik Maxitrol can be used. Use of other adapters can render the system inoperable.

NOTICE

The antenna (see page 26) must not cross or come into contact with the ignition wire. This will render the receiver inoperable.

Batteries – Receiver

NOTICE

Wiring of valve and receiver must be completed before starting ignition. Failure to do so could damage the electronics.

NOTICE

The handsets and receivers are not interchangeable with previous electronics G6R and B6R-R8(9)U(T).

⚠ WARNING

To avoid damaging the electronics, do NOT use metal tools to remove the batteries from the handset/receiver.

⚠ WARNING

- Without using a mains adapter, battery replacement is recommended at the beginning of each heating season.
- Old or dead batteries should be removed immediately. If left in the unit the batteries can overheat, leak, and/or explode.
- Do NOT expose batteries (including during storage) to direct sunlight, excessive heat, fire, moisture, or severe impact. Each of these conditions can cause the batteries to overheat, leak, and/or explode.
- Batteries must be kept within their recommended temperature limits (ambient battery temperature range: 32 °F to 131 °F / 0 °C to 55 °C).
- New and old batteries and different brands of batteries should not be used together. Mixing of various batteries can cause the batteries to overheat, leak, and/or explode.

- Low battery indication: frequent beeps for 3 seconds when motor turns.
- The V module for fan speed control and light/dimmer provides the receiver with power. The batteries in the receiver can be used for automatic backup in case of power outage.

NOTICE

To keep the receiver free from debris, dirt, and humidity, do not remove the receiver from the plastic bag until all construction is complete.

Radio Frequency Receiver and Handset

A code is selected automatically for all Merteik Maxitrol electronics from among 65,000 codes available. The receiver must be paired with a handset.

Synchronization Receiver/Symax Handset

(First time use only)

1. Insert batteries or connect AC mains power. The module for circulating fan and light/dimmer includes a mains adapter. With mains adapter, batteries can be used for backup.
2. Place **ON/OFF** switch (if equipped) to **ON** position.
3. The receiver has to learn the Symax code:
Press and hold the receiver's reset button (see figure 28, page 26) until you hear two (2) beeps. After the second, longer beep, release the reset button. Within the subsequent 20 seconds press the  button on the Symax. "CONN" and a running number from 1 to 8 are displayed on the Symax confirming the synchronization and data exchange is in process (see figure 13, page 7). Two (2) short beeps confirm the code is set. After successful synchronization the current state of the gas fire is displayed on the Symax.



Figure 13: Synchronization of Symax handset in process

NOTE: This is a one time setting only, and it is not required after changing the batteries in the Symax or receiver.

NOTE: Both the receiver and the Symax transmit and receive

signals (bidirectional). The Symax and receiver sync status information every 10s during the first 2 min and afterward every 4 to 6 min.

NOTE: When the RF receiver is placed in the appliance, the surrounding metal can reduce reception considerably.

NOTICE

The handsets and receivers are not interchangeable with previous electronics G6R and B6R-R8(9)U(T).

Synchronization Receiver/The Puck Handset

(First time use only)

1. Insert batteries or connect AC mains power. The module for circulating fan and light/dimmer includes a mains adapter. With mains adapter, batteries can be used for backup.
2. Place **ON/OFF** switch (if equipped) to **ON** position.
3. The receiver has to learn the Puck's code:
Press and hold the receiver's reset button (see figure 28, page 26) until you hear two (2) beeps. After the second, longer beep, release the reset button. Within the subsequent 20 seconds press and hold the "-" button on the Puck (approx. 4 seconds) until two (2) short beeps confirm the code is set.

NOTE: This is a one time setting only, and it is not required after changing the batteries in the Puck or receiver.

NOTE: The receiver transmits and receives (bidirectional) signals and the Puck (unidirectional) transmits signals. The Puck sends status information every 4 to 6 min to the receiver.

NOTE: When the RF receiver is placed in the appliance, the surrounding metal can reduce reception considerably.

NOTICE

The handsets and receivers are not interchangeable with previous electronics G6R and B6R-R8(9)U(T).

V MODULE

POWER SUPPLY

- CSA: Inlet: 115 VAC/60 Hz; 210 VA
Outlet: 115 VAC/60 Hz; 100 VA each
Built-in fuse: 2.5A
- CE: Inlet: 230 VAC/50 Hz; 210 VA
Outlet: 230 VAC/50 Hz; 100 VA each
Built-in fuse: 2.5A

AMBIENT TEMPERATURE RANGE

- CSA: V Module: 176 °F
- CE: V Module: 80 °C

POWER CONSUMPTION (STANDBY)

- CSA + CE: G6R-B...V3: 0.3 W

POWER CONSUMPTION (NOMINAL)

- CSA + CE: Depends on connected devices (fan, light)

Follow wiring diagram (see figure 31, page 29). Connect the Fan and Light first and then connect the power supply. An LED indicates the power is **ON**. Use Molex connectors or connect wires to screw terminals.

KNOB SETTINGS

Knobs function as follows (see figure 14, page 8):

KNOB	POSITION	FUNCTION
Main valve knob	OFF	Prevents main gas flow through valve.
Main valve knob	ON	Permits main gas flow through valve if the pilot is lit and thermocouple is generating sufficient power.
Manual knob	MAN	Allows the pilot to be manually ignited and prevents main gas flow.
Manual knob	ON	Allows for automatic ignition.

ADJUSTMENT

⚠ WARNING

It is the appliance manufacturer's responsibility to determine GV60's suitability for a specific application.

⚠ WARNING

Do not attempt to remove screws from the top of gas valve. Do not change any adjustments marked with tamper indicating paint. Motor knob is not to be removed.

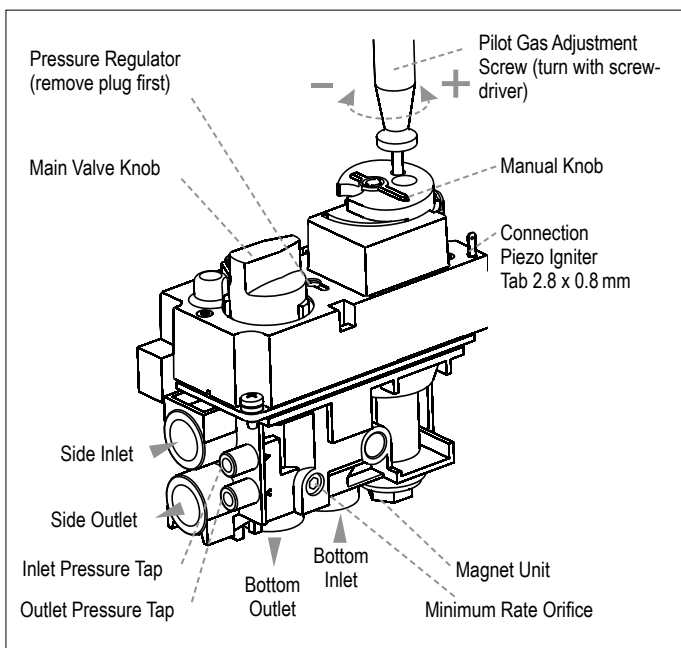

Figure 14: GV60, Connections and Adjustment Options

Pilot Flame Adjustment

(Vented Units Only)

The pilot flow adjustment is preset to maximum at the factory. The pilot flame should envelope $\frac{3}{8}$ " to $\frac{1}{2}$ " of the thermocouple (see figure 15, page 8).

1. The adjustment screw can be reached through a hole in the MANUAL knob (see figure 14, page 8).
2. Turn the MANUAL knob to the **ON** position.
3. It is now possible to pierce through a film on the cover with a screwdriver to reach the adjustment screw beneath.
4. Turn the adjustment screw clockwise ↻ to decrease or counterclockwise ↻ to increase pilot flame.

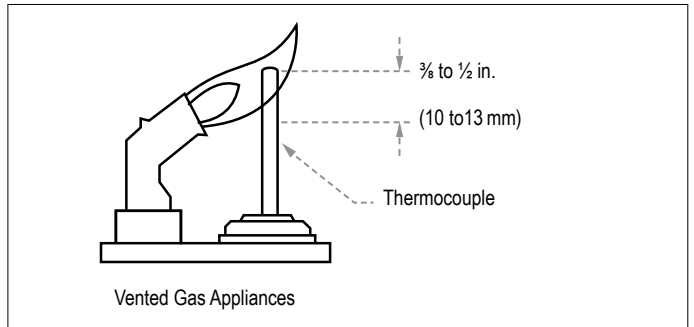

Figure 15: Proper Flame Impingement on Thermocouple

Outlet Pressure Adjustment

(Vented Units Only)

STANDARD REGULATOR OR THROTTLE

(Throttle CE Only)

1. Connect a pressure manometer to the valve outlet pressure tap. Pressure tap is opened by turning the screw counterclockwise ↻. Pressure regulator or throttle are located under the cover and can be reached by removing the plug (see figures 14, page 8 and 16, page 8).
2. Turn MANUAL knob and main valve knob to the **ON** position.
3. Turn pressure regulator adjustment screw to set required burner pressure (high fire). Pressure is increased by turning clockwise ↻ (pressure regulator models), or decreased by turning counterclockwise ↻.



Figure 16: Combination Control GV60, Cover

NOTE: Throttle model's pressure is increased by turning counterclockwise ↻; or decreased by turning clockwise ↻.

4. After adjustment, replace the plug.
5. If no other adjustments are required, close pressure tap(s) by turning the screw(s) full clockwise ↻. Check all connections/pressure tap(s) for leaks.
6. If the desired outlet pressure or flow cannot be achieved by adjusting the gas valve, check the gas valve inlet pressure using a manometer at the valve inlet pressure tap. If the inlet pressure is in the normal range, replace the gas valve; otherwise, take necessary steps to assure proper gas pressure to the valve.

CONVERTIBLE PRESSURE REGULATOR

(CSA Only; Optional)

Convertible regulators are designed to deliver either of two fixed outlet pressures for Natural Gas (NG) or LP Gas. To change from one gas to the other, turn the conversion plug (see figure 17, page 9) counter clockwise to remove. Unsnap and remove the plastic part, rotate it 180°, and then slide it back on the conversion plug until it snaps. Turn the conversion plug clockwise until it bottoms out.

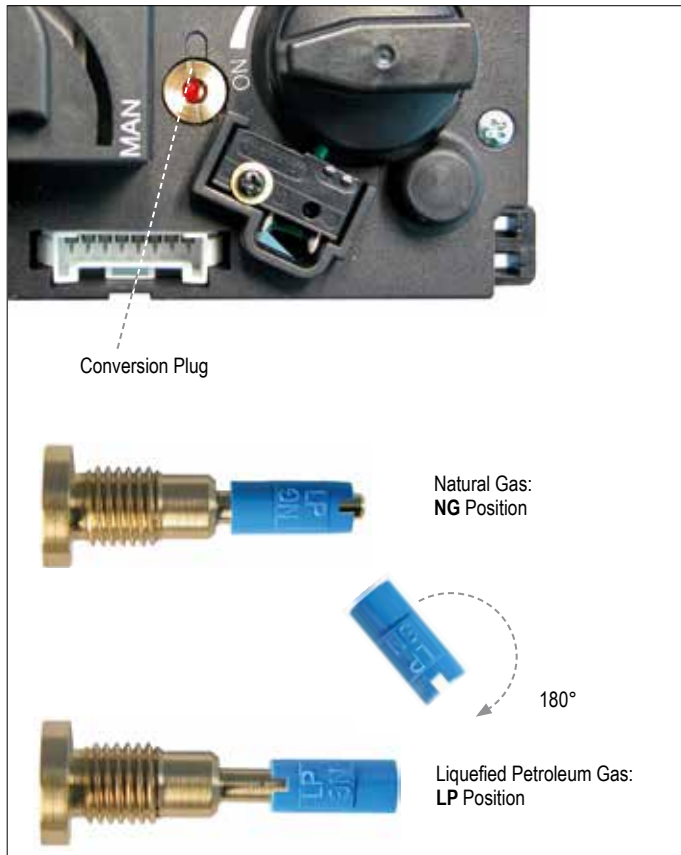

Figure 17: Conversion from one gas to another

Minimum Gas Flow Adjustment
(Vented Units Only)

1. Set the control into low fire setting by turning the motor knob to **OFF** position and back until the valve opens.
2. The minimum rate can be set either by screwing in a calibrated minimum rate screw (fixed orifice) or an adjustable minimum rate screw. Controls with adjustable screws without a customer specific setting are factory set at maximum flow.
3. Turn the screw clockwise ↻ to decrease the minimum flow.
4. Care should be taken to screw the fixed orifice until it stops.
5. Close pressure tap(s) by turning the screw(s) full clockwise ↻. Check all connections/pressure tap(s) for leaks.

Changing the Fuel Type
(Vented Units Only; see “Convertible Pressure Regulator”)

GV60 can be converted to meet the manufacturer’s requirements for a specific gas type. Adjustments of pressure regulator, minimum rate and pilot gas are according to above-mentioned instructions. To convert for LPG CE it is necessary to block the pressure regulator by turning the regulator adjustment screw fully to the bottom limit (or the throttle adjustment screw fully to the upper limit).

FINAL CHECK

Observe several complete **ON/OFF** cycles to ensure proper operation. During these cycles the electronics will determine the optimum ignition sequence timing.

1. **STOP!** Read the safety information included before proceeding.
2. Turn main valve knob to the **OFF**, full clockwise ↻ position.
3. Place **ON/OFF** switch (if equipped) to the **O (OFF)** position.
4. Wait a minimum of five (5) minutes to clear out any gas. Verify

that no gas is in the area around the appliance, including near the floor. **If you detect gas STOP! Follow “What to do if you smell gas” in the safety information (see page 2).** If no gas is present, proceed according to the Mertik Maxitrol Operating Instructions.

⚠ WARNING

Fire or Explosion Hazard. Attempted disassembly or repair can cause property damage, severe injury or death. Do not disassemble the gas valve; it contains no serviceable components.

MANUAL OPERATION

(Only possible, when MANUAL knob is used)

Access to the pilot burner is only required for ignition with a match.

When turning main valve knob, do not force. Knob has a slip clutch that clicks until the end stops are reached. This allows for manual flame height adjustment as well as adjustment to pilot-Standby position.

1. **STOP!** Read the safety information included before proceeding.
2. Turn main valve knob to the **OFF**, full clockwise ↻ position.
3. Turn **MANUAL** knob to the **MAN**, full clockwise ↻ position.
4. Place **ON/OFF** switch (if equipped) in **O (OFF)** position.
5. Wait five (5) minutes to clear out any gas. Verify that no gas is in the area around the appliance, including near the floor. **If you detect gas STOP! Follow “WHAT TO DO IF YOU SMELL GAS” in the safety information on page 2.** If no gas is present, proceed to step 6.
6. Place **ON/OFF** switch (if equipped) in **I (ON)** position.
7. With the **MANUAL** knob in **MAN** position a manual pilot valve operator and piezo ignitor (optional) are accessible.
8. Fully push down manual pilot valve operator and hold in, to start pilot gas flow (see figure 18, page 10).

Ignition with match:

Immediately light the pilot with a match, while continuing to hold in the manual pilot valve operator for about one (1) minute after the pilot is lit. Release manual pilot valve operator. If pilot does not stay lit, wait five (5) minutes and repeat.

Ignition with piezo ignitor:

Change the ignition cable from the receiver to the valve. Push in the piezo ignitor to ignite. If pilot does not stay lit, wait five (5) minutes and repeat.

⚠ WARNING

If the pilot does not stay lit after several tries, turn the gas control knob (main valve knob) to **OFF** and proceed to step 12.

9. If applicable, replace pilot access panel before proceeding.
10. Turn **MANUAL** knob to the **ON**, full counterclockwise ↺ position.
11. Turn main valve knob to the full **ON**, full counterclockwise ↺ position.
12. If the appliance will not operate, follow the instructions TO TURN OFF GAS TO APPLIANCE (see page 10).

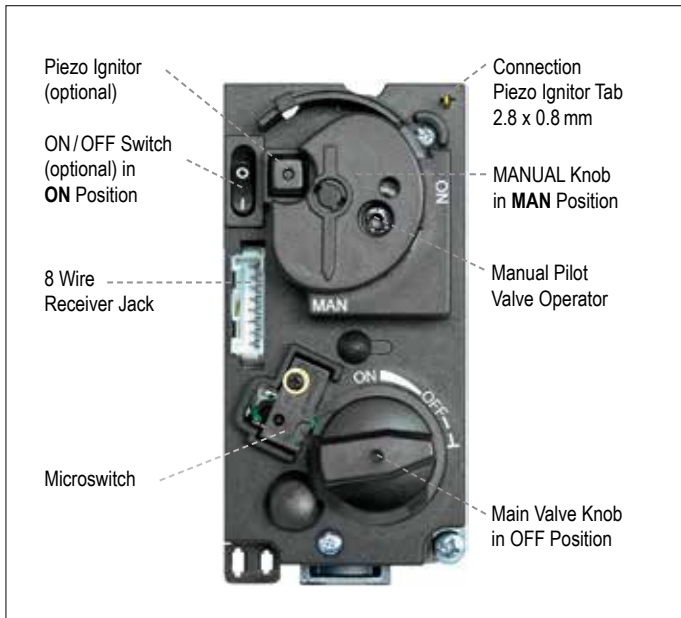

Figure 18: Combination control, cover

On-Demand pilot

- CSA: 7 Day Shut-Off
CE: 5 Day Shut-Off
- This green feature eliminates gas energy consumption during extended appliance inactivity. The system automatically extinguishes the pilot when the appliance is inactive for an extended period of time. This feature helps the consumer realize cost benefits by automatically eliminating energy consumption during non-heating months and limited use.

2nd Thermocouple Shut Off (optional)

- The system shuts off the fire if the main burner does not completely ignite in approximately 22–29 seconds (depending if receiver PT or PT2) after ignition or after pushing (▲) button.

NOTE: Before the next ignition there is a 2 minute waiting period. If the thermocouple is then still too hot, you will hear a long beep.

TO TURN OFF GAS TO APPLIANCE

1. Place **ON/OFF** switch (if equipped) in **O (OFF)** position.
2. If gas control is accessible turn main valve knob to the **OFF** full clockwise ↻ position.

AUTOMATIC TURN DOWN TO PILOT (MOTOR ENDSTOP)

3 Hour No Communication Function

- The valve will turn to pilot flame if there is no communication between handset and receiver for a 3 hour period. The fire will continue to function normally when communication is restored.

Receiver Overheating

The valve turns to pilot flame if the receiver temperature is higher than 176°F/80°C. If batteries are installed in the receiver the temperature must not exceed 140°F/60°C.

1 Hour Turn Down

(optional; requires specific handset)

- The valve will turn to pilot flame if there is no motor movement over a 1 hour period.

NOTE: In Manual Mode the main burner can be turned back **ON** after the receiver temperature is below 131°F/55°C (with batteries in receiver) or 176°F/80°C (without batteries in receiver). In Thermostatic Mode, the main burner turns back **ON** automatically.

AUTOMATIC SHUT OFF

Countdown Timer

- At end of Countdown Time period, the fire shuts off. The Countdown Timer only works in Manual, Thermostatic, and Eco Modes. Maximum Countdown Time is 9 hours and 50 minutes.

Low Battery Receiver

- With low battery power in the receiver the system shuts off the fire completely. This will not happen if the power supply is interrupted.

TOUCHPAD/WALL SWITCH

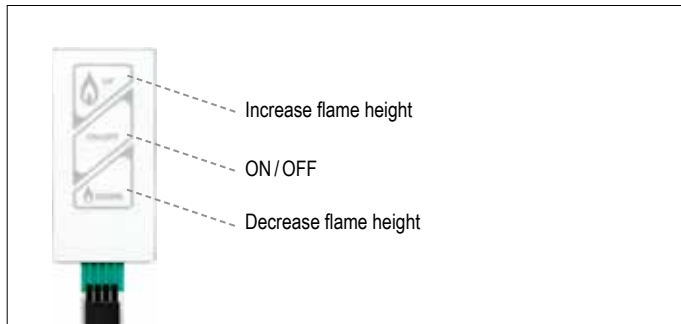

Figure 19: Touchpad/Wall Switch

AMBIENT TEMPERATURE RANGE

- CSA: Wall Switch/Touchpad: 176 °F
- CE: Wall Switch/Touchpad: 80 °C

To Turn ON Appliance

- Press **ON-OFF** button (see figure 19, page 11) until two short beeps (CE version) or continuous beeping (CSA version) confirm the start sequence has begun; release button.
- Once pilot ignition is confirmed, there is main gas flow.

⚠ WARNING

If the pilot does not stay lit after several tries, turn the main valve knob to **OFF** and follow the instructions "TO TURN OFF GAS TO APPLIANCE" (see page 10).

Flame Height Adjustment

- Press and hold 🔥 (large flame) button to increase flame height.
- Press and hold 🔥 (small flame) button to decrease flame height or to set appliance at pilot flame.

Standby Mode (Pilot Flame)

- Press and hold 🔥 (small flame) button to set appliance at pilot flame.

To Turn OFF Appliance

⚠ WARNING

If the appliance will not operate, follow the instructions "TO TURN OFF GAS TO APPLIANCE" (see page 10).

- Press **ON-OFF** button.

TO OPEN AND CLOSE SOLENOID VALVE/BURNER

- Simultaneously press the **ON-OFF** and 🔥 (small flame) buttons to switch the decorative burner **OFF**.
- Simultaneously press **ON-OFF** and 🔥 (large flame) buttons buttons to switch decorative burner on.

NOTE: The latching solenoid valve cannot operate manually. If the receiver battery runs down it will remain in the last operating position.

SWITCH PANEL

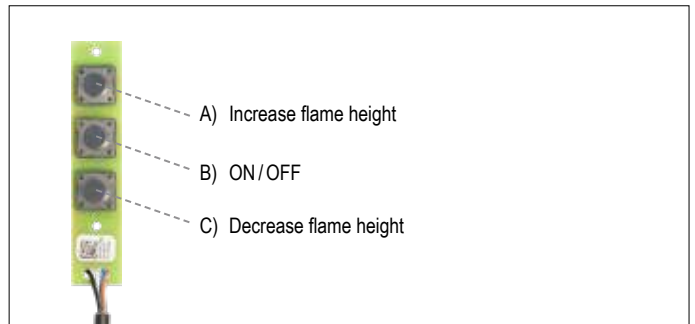

Figure 20: Switch Panel

AMBIENT TEMPERATURE RANGE

- CSA: Switch Panel: 221 °F
- CE: Switch Panel: 105 °C

To Turn ON Appliance

- Press "B" button (see figure 20, page 11) until two short beeps (CE version) or continuous beeping (CSA version) confirm the start sequence has begun; release button.
- Once pilot ignition is confirmed, there is main gas flow.

⚠ WARNING

If the pilot does not stay lit after several tries, turn the main valve knob to **OFF** and follow the instructions "TO TURN OFF GAS TO APPLIANCE" (see page 10).

Flame Height Adjustment

- Press and hold "A" button to increase flame height.
- Press and hold "C" button to decrease flame height or to set appliance at pilot flame.

Standby Mode (Pilot Flame)

- Press and hold "C" button to set appliance at pilot flame.

To Turn OFF Appliance

⚠ WARNING

If the appliance will not operate, follow the instructions "TO TURN OFF GAS TO APPLIANCE" (see page 10).

- Press "B" button.

TO OPEN AND CLOSE SOLENOID VALVE/BURNER

- Simultaneously press the "B" and "C" buttons to switch the decorative burner **OFF**.
- Simultaneously press "B" and "A" buttons buttons to switch decorative burner on.

NOTE: The latching solenoid valve cannot operate manually. If the receiver battery runs down it will remain in the last operating position.

SYMAX HANDSET

TECHNICAL DATA

AMBIENT TEMPERATURE RANGE

CSA: Handset: 32 °F to 131 °F
CE: Handset: 0 °C to 55 °C

RADIO FREQUENCY

CSA: 918.0 MHz for U.S. (FCC), Canada (ISED), New Zealand (RNZ) and Australia (ACMA) (handset, receiver)
CE: 868.1 MHz for Europe (handset, receiver)
(see general radio frequency information on page 4.)

RADIATED POWER OUTPUT

CSA: 90.8 µV/m
CE: -3.5 dBm

POWER SUPPLY

Handset: 2 x 1.5V "AAA" (quality alkaline recommended)

NOTICE

Wiring of valve and receiver must be completed before starting ignition. Failure to do so could damage the electronics.

NOTICE

The handsets and receivers are not interchangeable with previous electronics G6R and B6R-R8(9)U(T).

⚠ WARNING

To avoid damaging the electronics, do NOT use metal tools to remove the batteries from the handset/receiver.

⚠ WARNING

- Without using a mains adapter, battery replacement is recommended at the beginning of each heating season.
- Old or dead batteries should be removed immediately. If left in the unit the batteries can overheat, leak, and/or explode.
- Do NOT expose batteries (including during storage) to direct sunlight, excessive heat, fire, moisture, or severe impact. Each of these conditions can cause the batteries to overheat, leak, and/or explode.
- Batteries must be kept within their recommended temperature limits (ambient battery temperature range: 32 °F to 131 °F / 0 °C to 55 °C).
- New and old batteries and different brands of batteries should not be used together. Mixing of various batteries can cause the batteries to overheat, leak, and/or explode.

SYNCHRONIZATION RECEIVER/SYMAX HANDSET

NOTICE

See page 7 for more information about synchronization between receiver and Symax.

GENERAL NOTES

Batteries – Handset

Low battery indicator on Symax.

Handset One Button and Two Button Ignition

Change from one button (default setting) to two button ignition or vice versa by pressing and holding  button for 10 sec. immediately after installing batteries. **ON** is displayed and **1** or **2** (One or Two Button Ignition) is flashing. When change is complete **1** changes to **2** or vice versa.

Deactivate Functions

1. Install batteries. All icons are displayed and flashing.
2. While the icons are flashing, press the relevant function button and hold for 10 sec.
3. The function icon will flash until deactivation is complete. Deactivation is complete when the function icon and two horizontal bars are displayed.

NOTE: If a deactivated button is pressed, there is no function, and two horizontal bars are displayed.

NOTE: Deactivation remains in effect after change of batteries.

Activate Functions

1. Install batteries. All icons are displayed and flashing.
2. To activate a function, press the relevant button and hold for 10 sec.
3. The function icon will continue to flash until activation is complete. Activation is complete when the function icon is displayed.

The following Functions can be Deactivated/Activated

- CHILD PROOF
- PROGRAM MODE
- THERMOSTATIC MODE (also deactivates PROGRAM MODE)
- ECO MODE
- LIGHT/DIMMER OPERATION
- CIRCULATING FAN OPERATION
- 2ND BURNER FEATURE
- COUNTDOWN TIMER

8-BUTTON OPERATION

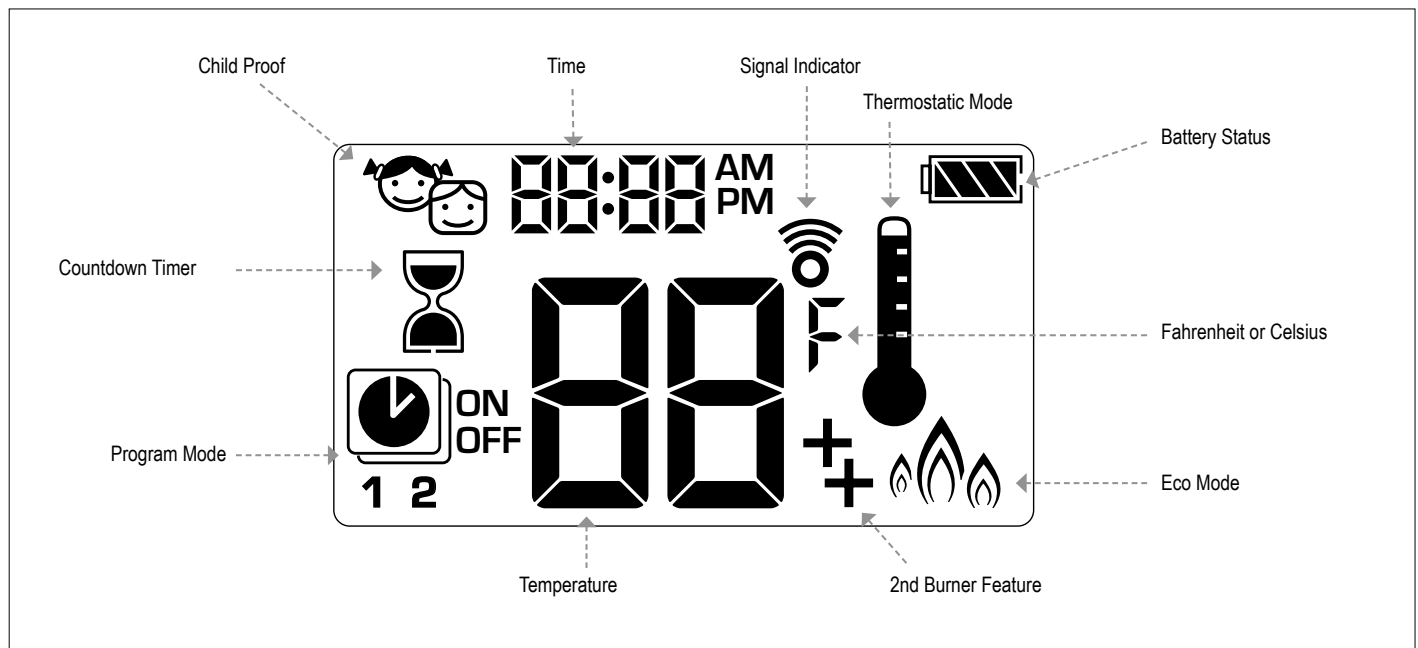
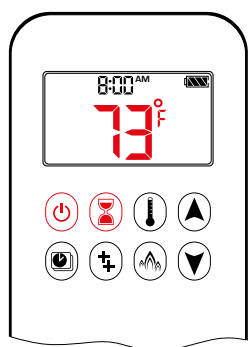

Figure 21: 8-button Display

SETTING FAHRENHEIT OR CELSIUS



- To change between °C and °F, press and buttons simultaneously.

NOTE: Choosing °F results in a 12 hour clock. Choosing °C results in a 24 hour clock.

CHILD PROOF

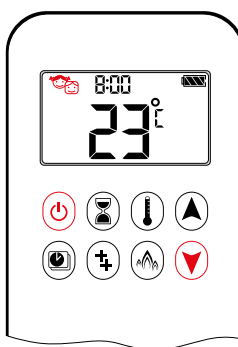

- ON:**
- To activate press and buttons simultaneously.
 - is displayed and the Symax is rendered inoperable, except for the **OFF** function.
- OFF:**
- To deactivate press and buttons simultaneously.
 - disappears.

SETTING THE TIME

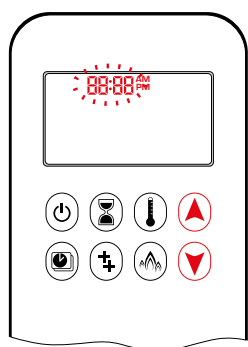

- Press and buttons simultaneously. **Day** flashes.
- Press or button to select a number to correspond with the day of the week (e.g. 1=Monday, 2=Tuesday, 3=Wednesday, 4=Thursday, 5=Friday, 6=Saturday, 7=Sunday).
- Press and buttons simultaneously. **Hour** flashes.
- To select hour press or button.
- Press and buttons simultaneously. **Minutes** flash.
- To select minutes press or button.
- To confirm press and buttons simultaneously or wait.

ENGLISH

MANUAL MODE (HANDSET)

NOTICE

BEFORE OPERATING

1. Make sure MANUAL knob on the GV60 valve is in the **ON**, full counterclockwise ↺ position.
2. Place the **ON/OFF** switch (if equipped) in the I (**ON**) position.

TO TURN ON FIRE

⚠ WARNING

When pilot ignition is confirmed, motor turns automatically to maximum flame height.

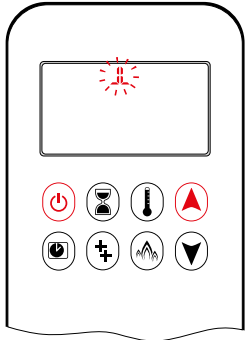

- Press ⏻ button (One Button Ignition) or ⏻ and ▲ button simultaneously (Two Button Ignition) until two short beeps (CE version) or continuous beeping (CSA version) and a blinking series of lines confirms the start sequence has begun; release button(s).
- Main gas flows once pilot ignition is confirmed.
- The Symax automatically goes into Manual Mode after main burner ignition.

⚠ WARNING

If the pilot does not stay lit after several tries, turn the main valve knob to **OFF** and follow the instructions "TO TURN OFF GAS TO APPLIANCE" (see page 10).

STANDBY MODE (PILOT FLAME)

Handset

- Press and hold ▼ button to set appliance to pilot flame.

TO TURN OFF FIRE

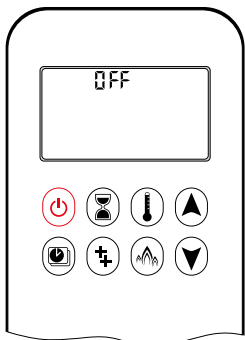

Handset

- Press ⏻ button to turn **OFF**.

NOTE: A new ignition is possible after the **OFF** icon stops flashing.

FLAME HEIGHT ADJUSTMENT

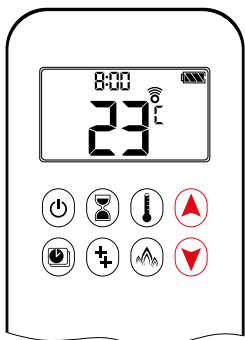

Handset

- To increase flame height press and hold ▲ button.
- To decrease flame height or to set appliance to pilot flame, press and hold ▼ button.

DESIGNATED LOW FIRE AND HIGH FIRE

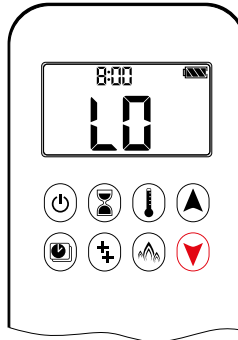

- To go to low fire, double-click ▼ button.
- LO is displayed.

NOTE: Flame goes to high fire first before going to low fire.

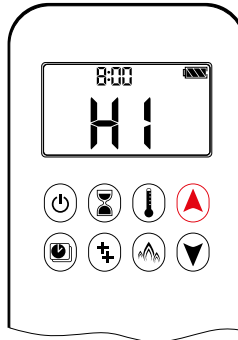

- To go to high fire, double-click ▲ button.
- HI is displayed.

⚠ WARNING

If the appliance will not operate, follow the instructions "TO TURN OFF GAS TO APPLIANCE" (see page 10).

COUNTDOWN TIMER

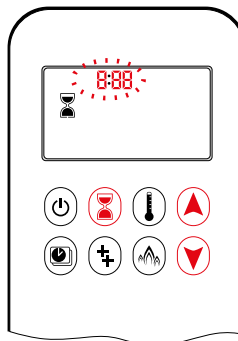

ON/SETTING:

1. Press and hold ⏻ button until ⏻ is displayed, and **hour** flashes.
2. To select hour press ▲ or ▼ button.
3. To confirm press ⏻ button. **Minutes** flash.
4. To select minutes press ▲ or ▼ button.
5. To confirm press ⏻ button or wait.

OFF:

Press ⏻ button, ⏻ and Countdown Time disappear.

NOTE: At end of Countdown Time period, the fire shuts **OFF**. The Countdown Timer only works in Manual, Thermostatic, and Eco Modes. Maximum Countdown Time is 9 hours and 50 minutes.