

REV.	DATE	REMARK
1	2/24/2011	INITAL RELEASE
2		
3		

- Note:
- 1)All electrolytic capacitors are 16V or above, +80%-20% except specified.
 - 2)All ceramic capacitors are 16V or above, +80%-20% except specified.
 - 3)All resistors are +/-5% except specified.
 - 4)All diodes are 1N4148 except specified.
 - 5)* Adjust by factory to achieve the correct sensitivity.
 - 6)In PCB layout,the trace separation between VCC and GND should be minimum 1.5mm.
 - 7)Fuse/Polyswitch with its surrounding 1.5mm around should be free of trace.

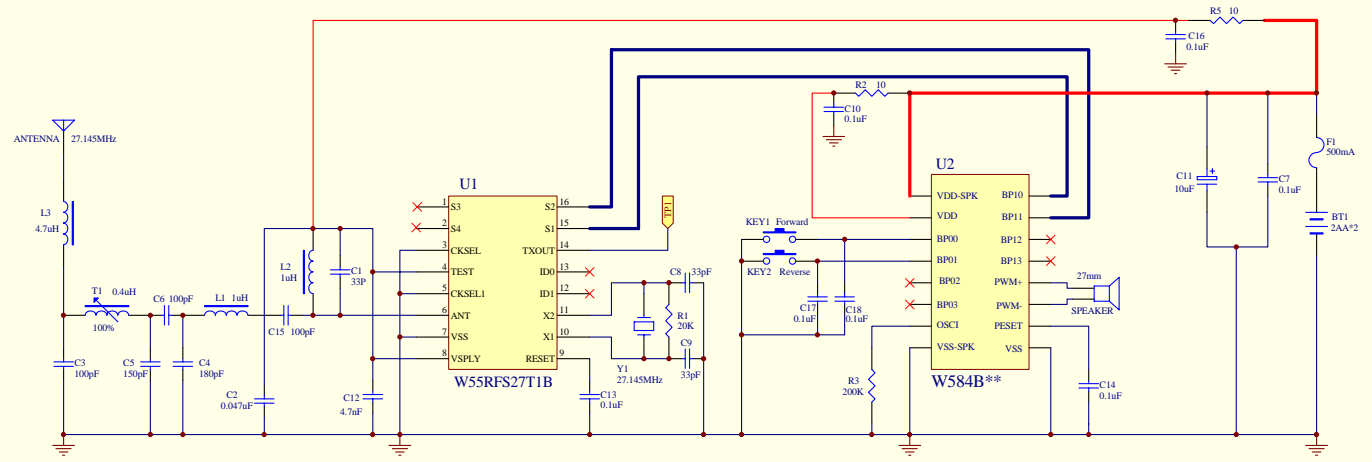

TX Schematic

Model Name: A0294	Model No. A02940000
DWG.NO:	ENGINEER: NQ Chen 1/13/2012
File Name: A0294TX	CHECKED:
PAGE: 1 OF 1	APPROVED: WJ Lai 1/13/2012
Revision:	
Hasbro Far East Limited	