

## Functional Description in Vehicle:

(1) 5V Power Regulator(U1):

It is used to provide a stable power for L/R Motor Driver.

(2) 3.3V Power Regulator(U2):

It used to provide a stable power for MCU and RF Module.

(3) Decoder & Speed Control:

It is a MCU(IC1,N79A049) which is used to control all the peripheral components such as RF Module, FW/BW Motor Driver, L/R Motor Driver and Temperature Sensor. The main function of this MCU is used to decode the receiving data from the RF Module. According to the decoded data, the MCU will generate a signal to control F/W and L/R Motor Drivers.

(4) RF Module(TNT-7105):

It is a 2.4GHz ISM band wireless transceiver which is controlled by MCU.

(5) Temperature Sensor(T1):

It is used to detect the battery temperature. If the temperature of the battery is over 54°C, the MCU will stop all the operations.

Antenna:

Internal, integral antenna is used.

**Below is the frequency table of the controller.**

Car(transmission channel : 15)			
2409	2422	2443	
2411	2426	2446	
2414	2433	2451	
2416	2436	2459	
2421	2442	2461	

Car(receiveing channel : 19)			
2407	2418	2434	2449
2408	2419	2439	2450
2410	2424	2440	2455
2412	2425	2442	2462
2417	2429	2448	

## 2.4GHz FSK / GFSK Transceiver Module

**TNT-7105**

**Data Sheet**

Trinity Electronics Limited

## Contents

Contents .....	2
General Description .....	3
Electrical specification .....	3
Pad Description .....	4
Block Diagram .....	5
Circuit Diagram .....	6
Application circuit .....	7
SPI serial bus (4 wires) .....	7
Serial bus (3 wires) .....	7
Bill of Materials .....	8
Data Sheet Document History .....	9

Trinity Electronics Limited

## General Description

The TNT-7105 module is designed for 2.4GHz ISM band wireless application using FSK / GFSK transceiver. This module features a fully programmable frequency synthesizer by SPI. The maximum data rate is 500Kbps.

## Electrical specification

Item	Specification	Remark
Supply Voltage	1.9V ~ 3.6V	
Current consumption	0.7uA @Sleep mode 0.3mA @Idle mode 1.7mA @Stand-by mode 15.5mA @Rx mode 20.5mA @Tx mode (Pout=0dBm)	Typical
Frequency	2400 – 2483MHz	ISM band
Transmit output power	0 dBm @ room temperature	Typical
Rx sensitivity	-107dBm (typical) @2Kbps mode, Dev = 124KHz -104dBm (typical) @25Kbps mode, Dev = 124KHz -97dBm (typical) @250Kbps mode, Dev = 186KHz -95dBm (typical) @500Kbps mode, Dev = 186KHz	BER ≤ 1E-3
Modulation	FSK or GFSK	
Transmission distance	18 meter	BER ≤ 1E-3
Interface	4 x 2 pin 2.45mm header	
Dimension	23.3mm(L) x 12.4mm (W) x 5mm(H)	Not include connector
Operating temperature	-40 ~ 85 °C	

## Pad Description

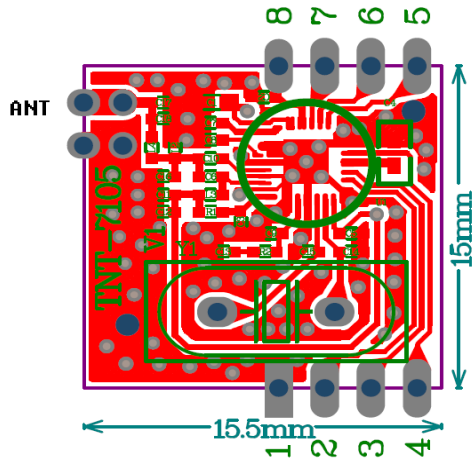

Pad No.	Symbol	Function Description	Remark
1	GND	Ground	
2	SCS	SPI Chip Selection	
3	SCK	SPI Clock	
4	SDIO	SPI read /write data pin	
5	GIO1	Multi-function IO1	
6	GIO2	Multi-function IO2	
7	NC	No Connection	
8	VIN	Supply voltage	1.9V ~ 3.6V

## Block Diagram

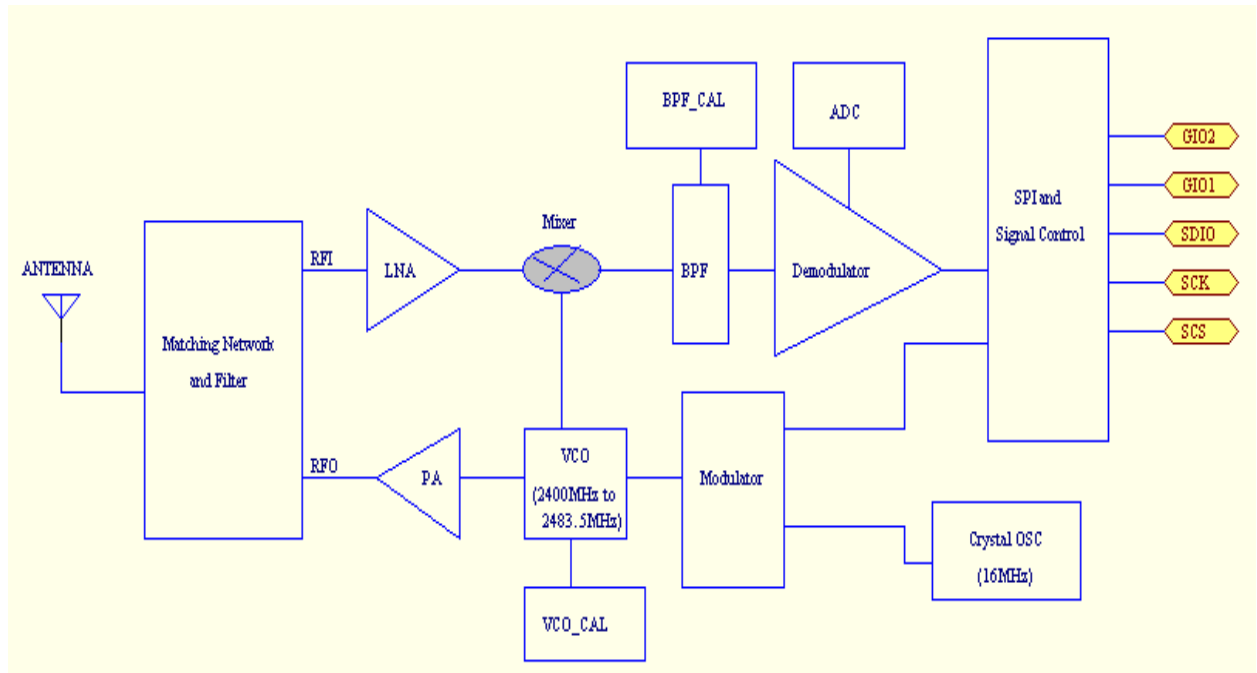

## Circuit Diagram

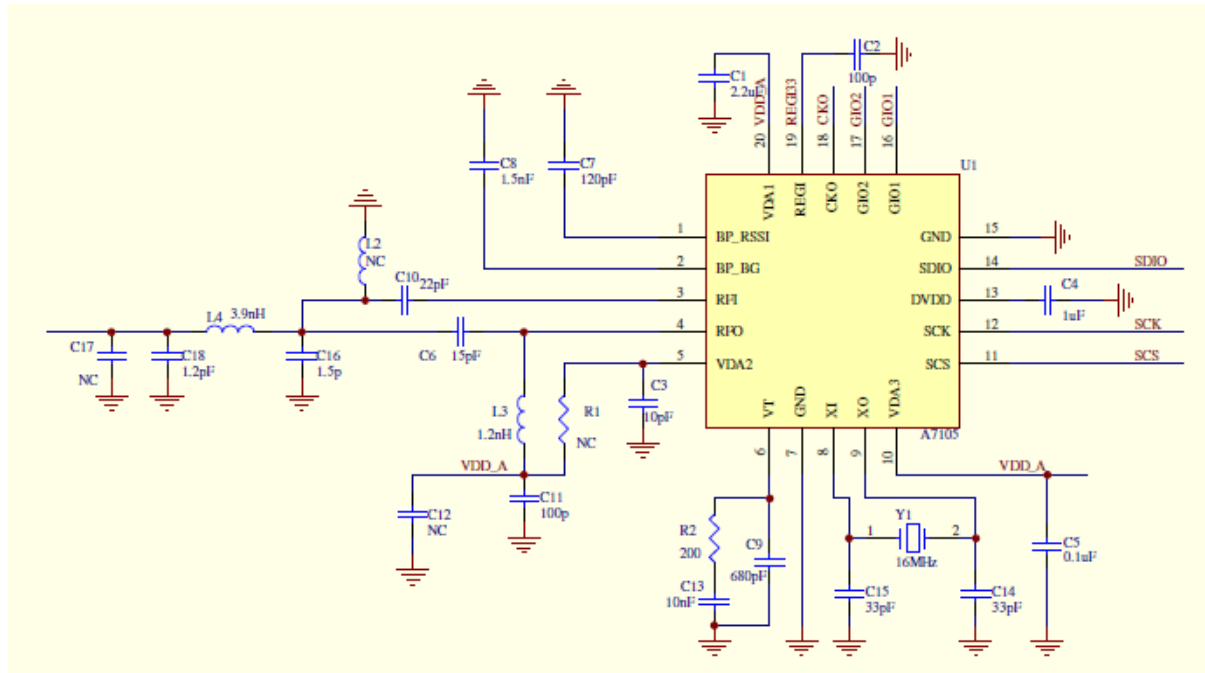

## Application circuit

### SPI serial bus (4 wires)

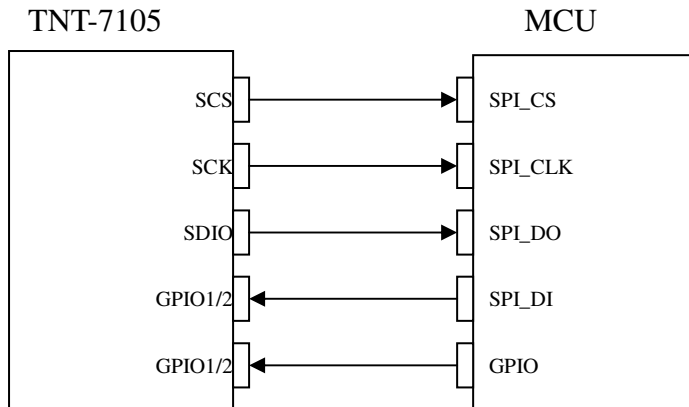

### Serial bus (3 wires)

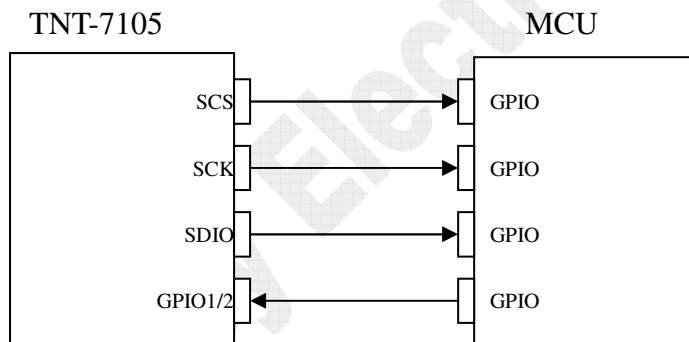



## Bill of Materials

Item	Designator	Description	Size	Value	Tol.	Remark
1	C1	Y5V Ceramic Capacitor	0402	2.2uF	20%	Annotation1
2	C2	Y5V Ceramic Capacitor	0402	100pF	20%	Annotation1
3	C3	Y5V Ceramic Capacitor	0402	10pF	5%	
4	C4	Y5V Ceramic Capacitor	0402	1uF	20%	Annotation1
5	C5	Y5V Ceramic Capacitor	0402	0.1uF	20%	
6	C6	NPO Ceramic Capacitor	0402	15pF	5%	Tx matching circuit
7	C7	NPO Ceramic Capacitor	0402	120pF	10%	
8	C8	X7R Ceramic Capacitor	0402	1.5nF	10%	
9	C9	X7R Ceramic Capacitor	0402	680pF	10%	PLL Loop Filter
10	C10	NOP Ceramic Capacitor	0402	22pF	5%	Rx matching circuit
11	C11	NOP Ceramic Capacitor	0402	100pF	5%	Tx matching circuit
12	C13	X7R Ceramic Capacitor	0402	10nF	10%	PLL Loop Filter
13	C14	NOP Ceramic Capacitor	0402	33pF	5%	Annotation2
14	C15	NOP Ceramic Capacitor	0402	33pF	5%	Annotation2
15	C16	NOP Ceramic Capacitor	0402	1.5pF	0.25pF	LPF
16	C17	NOP Ceramic Capacitor	0402	NC		
17	C18	NOP Ceramic Capacitor	0402	1.2pF	0.25pF	LPF
18	L3	Chip inductor	0402	1.2nH	0.1nH	Viking AL02BT1N2
19	L4	Chip inductor	0402	3.9nH	0.1nH	Viking AL02BT3N1
20	R2	Chip resistor	0402	200ohm	5%	PLL Loop Filter
21	U1	A7105	QFN 20(4x4)			
22	U2	Crystal	49US	16MHz	20ppm	

## Data Sheet Document History

Revision	Date	Description
A1	2011 / 6	Preliminary version I

Trinity Electronics Limited