

PLAY:

Playing with the BOUNCE BACK RACER™ is simple and fun. Just turn the ON/OFF switch on the back of the car to "ON" and use the r/c controller to drive it. There are two buttons on the controller: forward and reverse. When the racer runs into an obstacle, it may either bounce off of it or even flip over!

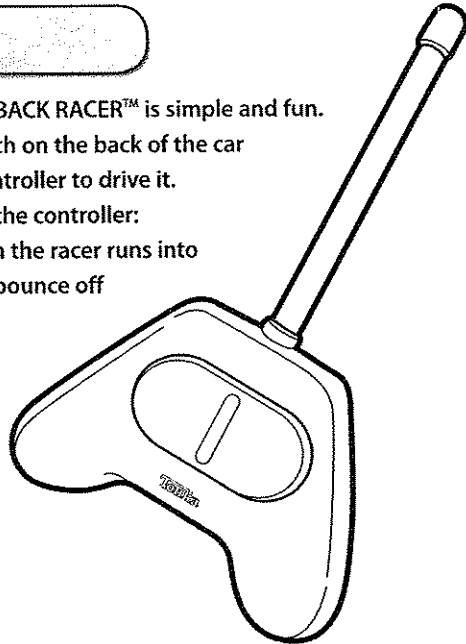

FCC STATEMENT

This device complies with part 15 of the FCC Rules. Operation is subject to the following two conditions: (1) This device may not cause harmful interference, and (2) this device must accept any interference received, including interference that may cause undesired operation.

CAUTION: Changes or modifications not expressly approved by the party responsible for compliance could void the user's authority to operate the equipment.

NOTE: Adult should remove and discard plastic fasteners and all packaging materials.



Product and colors may vary.
© 2008 Hasbro. All Rights Reserved.
TM & ® denote U.S. Trademarks.
09996/09995 Asst.

P/N 6808890000



Questions? Call: 1-800-PLAYSKL

PLAYSKOOL
believe in PLAY™

Tonka®

Bounce Back Racer™

Includes car, wireless controller and instructions.

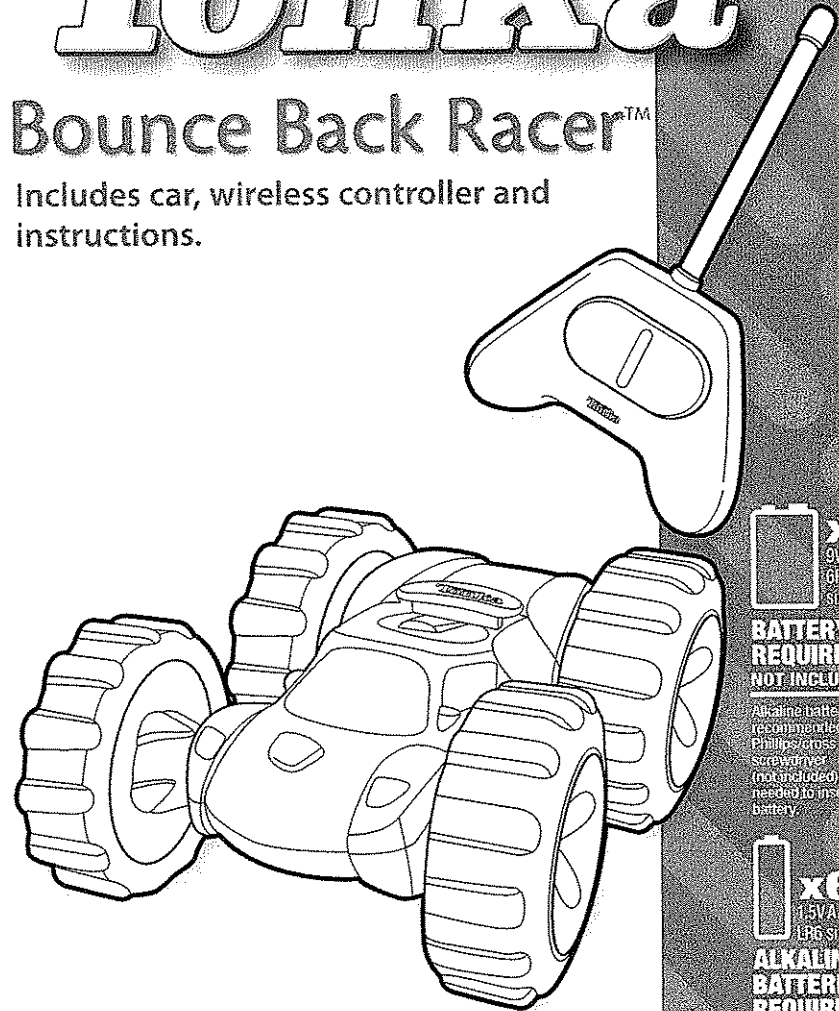

AGES 3+
09996/09995 Asst.



**BATTERY REQUIRED
NOT INCLUDED**

Alkaline battery (recommended)
Phillips/cross head screwdriver (not included)
needed to insert battery



**ALKALINE BATTERIES REQUIRED
NOT INCLUDED**

Phillips/cross head screwdriver (not included)
needed to insert batteries



CAUTION:

Hair entanglement may result if child's hair comes in contact with moving parts of toy. Adult supervision is required.

TO INSTALL BATTERY IN WIRELESS CONTROLLER:

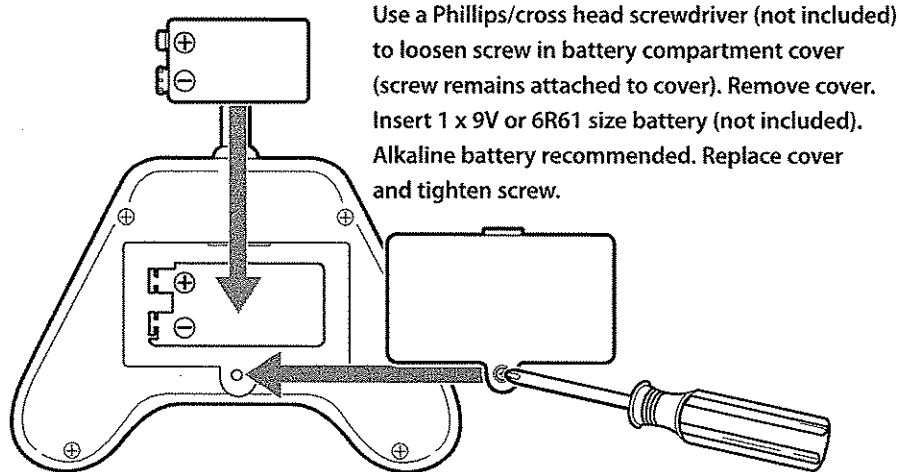

Use a Phillips/cross head screwdriver (not included) to loosen screw in battery compartment cover (screw remains attached to cover). Remove cover. Insert 1 x 9V or 6R61 size battery (not included). Alkaline battery recommended. Replace cover and tighten screw.

TO INSTALL BATTERIES IN CAR:

NOTE: There are two battery compartments; each holds 3 batteries.

Use a Phillips/cross head screwdriver (not included) to loosen screws in battery compartment covers (screws remain attached to covers). Remove covers. Insert 6 x 1.5V "AA" or LR6 size alkaline batteries (not included). Replace covers and tighten screws.

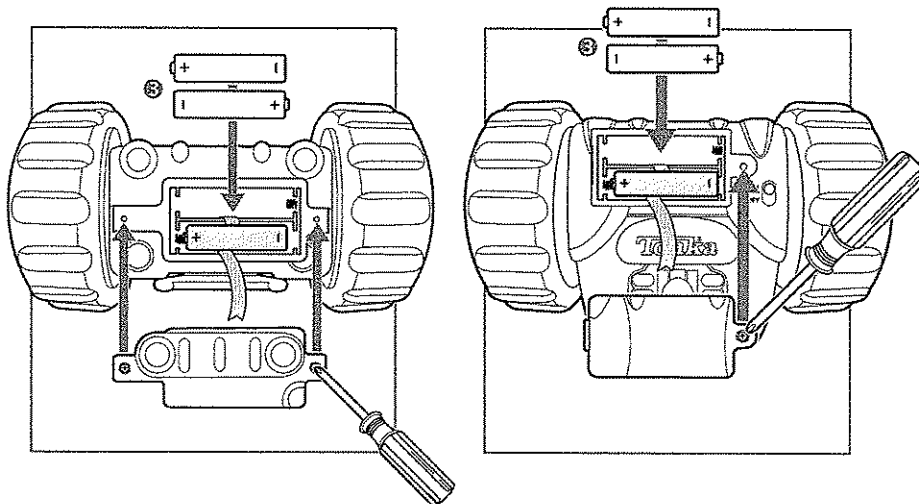

⚠ CAUTION: TO AVOID BATTERY LEAKAGE

1. Be sure to insert the batteries correctly and always follow the toy and battery manufacturers' instructions;
2. Do not mix old and new batteries or alkaline, standard (carbon-zinc) or rechargeable (nickel-cadmium) batteries;
3. Always remove weak or dead batteries from the product.

IMPORTANT: BATTERY INFORMATION

Please retain this information for future reference.

Batteries should be replaced by an adult.

⚠ CAUTION:

1. Always follow the instructions carefully. Use only batteries specified and be sure to insert them correctly by matching the + and - polarity markings.
2. Do not mix old batteries and new batteries, or standard (carbon-zinc) with alkaline batteries.
3. Remove exhausted or dead batteries from the product.
4. Remove batteries if product is not to be played with for a long time.
5. Do not short-circuit the supply terminals.
6. Should this product cause, or be affected by, local electrical interference, move it away from other electrical equipment. Reset (switching off and back on again or removing and re-inserting batteries) if necessary.
7. RECHARGEABLE BATTERIES: Do not mix these with any other types of batteries. Always remove from the product before recharging. Recharge batteries under adult supervision. DO NOT RECHARGE OTHER TYPES OF BATTERIES.

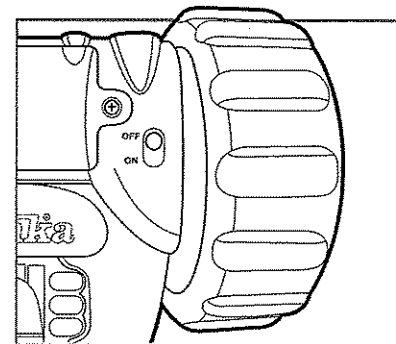

NOTE: If toy stops working, turn off vehicle, wait 5 seconds and turn back on. If it still does not work, turn off and leave off for 5 minutes. Then turn on and resume normal use.

To conserve batteries, be sure to switch car to "off" when not in use.