



Valued Quality. Delivered.

## TEST REPORT

Report No.: 17030749HKG-001

**Hasbro Far East Ltd.**

Application  
For  
Certification  
(Original Grant)  
**(FCC ID: RS4-C1364)**

Transceiver

Prepared and Checked by:

Approved by:

Signed On File  
Leung Sung Tak, Andy  
Engineer

---

Wong Kwok Yeung, Kenneth  
Senior Lead Engineer  
Date: May 09, 2017

- Intertek's standard Terms and Conditions can be obtained at our website <http://www.intertek.com/terms/>.
- The test report only allows to be revised within the retention period unless further standard or the requirement was noticed.
- This report is for the exclusive use of Intertek's Client and is provided pursuant to the agreement between Intertek and its Client. Intertek's responsibility and liability are limited to the terms and conditions of the agreement. Intertek assumes no liability to any party, other than to the Client in accordance with the agreement, for any loss, expense or damage occasioned by the use of this report. Only the Client is authorized to permit copying or distribution of this report and then only in its entirety. Any use of the Intertek name or one of its marks for the sale or advertisement of the tested material, product or service must first be approved in writing by Intertek. The observations and test results in this report are relevant only to the sample tested. This report by itself does not imply that the material, product, or service is or has ever been under an Intertek certification program.
- © 2016 Intertek

**Intertek Testing Services Hong Kong Ltd.**

2/F., Garment Centre, 576 Castle Peak Road, Kowloon, Hong Kong.

Tel: (852) 2173 8888 Fax: (852) 2785 5487 Website: [www.hk.intertek-ettsemko.com](http://www.hk.intertek-ettsemko.com)

## INTERTEK TESTING SERVICES

---

### GENERAL INFORMATION

Grantee:	Hasbro Far East Ltd.
Grantee Address:	1308, World Commerce Centre, Harbour City, 11 Canton Road, Tsim Sha Tsui, Kowloon, Hong Kong.
Contact Person:	Richard Leung
Tel:	(852) 2737 7446
Fax:	(852) 2737 6448
e-mail:	N/A
Manufacturer:	Hasbro SA
Manufacturer Address:	Rue Emile-Boechat 31, 2800 Delemont CH, CH-2800 Delemont, Switzerland.
Buyer:	Hasbro
Brand Name:	N/A
Model:	C1364
Additional Model:	C1253
Vendor Code:	ZC-001
Factory Code:	C
Type of EUT:	Transceiver
Description of EUT:	Star Wars Force Link Starter Set (C1364), Star Wars BB-8 2-In-1 Mega Playset (C1253)
Serial Number:	N/A
FCC ID:	RS4-C1364
Date of Sample Submitted:	March 14, 2017
Date of Test:	March 14, 2017 to April 26, 2017
Report No.:	17030749HKG-001
Report Date:	May 09, 2017
Environmental Conditions:	Temperature: +10 to 40°C Humidity: 10 to 90%

## INTERTEK TESTING SERVICES

---

### SUMMARY OF TEST RESULT

TEST SPECIFICATION	REFERENCE	RESULTS
Transmitter Field Strength Frequency Stability	15.225	Pass
Radiated Emission Radiated Emission on the Bandedge	15.209	Pass
Radiated Emission in Restricted Bands	15.205	Pass

The equipment under test is found to be complying with the following standards:  
FCC Part 15, October 1, 2015 Edition

- Note: 1. The EUT uses a permanently attached antenna which, in accordance to section 15.203, is considered sufficient to comply with the provisions of this section.
2. Pursuant to FCC part 15 Section 15.215(c), the 20 dB bandwidth of the emission was contained within the frequency band designated (mentioned as above) which the EUT operated. The effects, if any, from frequency sweeping, frequency hopping, other modulation techniques and frequency stability over excepted variations in temperature and supply voltage were considered.

---

# INTERTEK TESTING SERVICES

---

## Table of Contents

1.0	<b><u>General Description</u></b> .....	1
1.1	Product Description .....	1
1.2	Related Submittal(s) Grants.....	1
1.3	Test Methodology .....	1
1.4	Test Facility .....	1
2.0	<b><u>System Test Configuration</u></b> .....	2
2.1	Justification.....	2
2.2	EUT Exercising Software.....	2
2.3	Special Accessories .....	2
2.4	Measurement Uncertainty.....	2
2.5	Support Equipment List and Description.....	3
3.0	<b><u>Emission Results</u></b> .....	4
3.1	Field Strength Calculation.....	4
3.2	Radiated Emission Configuration Photograph .....	5
3.3	Radiated Emission Data .....	5
3.4	<b><u>Frequency Stability</u></b> .....	8
4.0	<b><u>Equipment Photographs</u></b> .....	9
5.0	<b><u>Product Labelling</u></b> .....	9
6.0	<b><u>Technical Specifications</u></b> .....	9
7.0	<b><u>Instruction Manual</u></b> .....	9
8.0	<b><u>Miscellaneous Information</u></b> .....	10
8.1	Measured Bandwidth.....	10
8.2	Discussion of Pulse Desensitization .....	11
8.3	Calculation of Average Factor.....	11
8.4	Emissions Test Procedures .....	11
9.0	<b><u>Confidentiality Request</u></b> .....	14
10.0	<b><u>Equipment List</u></b> .....	14

## INTERTEK TESTING SERVICES

---

### 1.0 General Description

#### 1.1 Product Description

The Equipment Under Test (EUT) is a Force Link Starter Set, which contains a 13MHz NFC reader. The EUT is powered by 3 X 1.5V AAA batteries. After placing the tags on the EUT, the EUT will recognize the tags with sending out different sound effects.

The Model: C1253 is the same as the Model: C1364 in hardware aspect. The models are different in packaging and accessories only.

Antenna Type: Internal, Integral

For electronic filing, the brief circuit description is saved with filename: descri.pdf.

#### 1.2 Related Submittal(s) Grants

This is a single application for certification of a transceiver.

#### 1.3 Test Methodology

Radiated emission measurements was performed according to the procedures in ANSI C63.10 (2013). All radiated measurements were performed in an 3m Chamber. Preliminary scans were performed in the 3m Chamber only to determine worst case modes. All radiated tests were performed at an antenna to EUT distance of 3 meters, unless stated otherwise in the “**Justification Section**” of this Application.

#### 1.4 Test Facility

The 3m Chamber facility used to collect the radiated data is located at Workshop No. 3, G/F., World-Wide Industrial Centre, 43-47 Shan Mei Street, Fo Tan, Sha Tin, N.T., Hong Kong. This test facility and site measurement data have been placed on file with the FCC.

## INTERTEK TESTING SERVICES

---

### 2.0 **System Test Configuration**

#### 2.1 Justification

The system was configured for testing in a typical fashion (as a customer would normally use it), and in the confines as outlined in ANSI C63.10 (2013).

The device was powered by new 3 x 1.5V AAA Batteries.

For maximizing emissions below 30 MHz, the EUT was rotated through 360°, the centre of the loop antenna was placed 1 meter above the ground, and the antenna polarization was changed. For maximizing emission at and above 30 MHz, the EUT was rotated through 360°, the antenna height was varied from 1 meter to 4 meters above the ground plane, and the antenna polarization was changed. This step by step procedure for maximizing emissions led to the data report in Exhibit 3.0.

The rear of unit shall be flushed with the rear of the table.

The equipment under test (EUT) was configured for testing in a typical fashion (as a customer would normally use it). The EUT was mounted to a plastic stand if necessary and placed on the wooden turntable, which enabled the engineer to maximize emissions through its placement in the three orthogonal axes.

#### 2.2 EUT Exercising Software

There was no special software to exercise the device. Once the unit is powered up, it transmits the RF signal continuously.

#### 2.3 Special Accessories

There are no special accessories necessary for compliance of this product.

#### 2.4 Measurement Uncertainty

When determining of the test conclusion, the Measurement Uncertainty of test has been considered.

Uncertainty and Compliance - Unless the standard specifically states that measured values are to be extended by the measurement uncertainty in determining compliance, all compliance determinations are based on the actual measured value.

## INTERTEK TESTING SERVICES

### 2.5 Support Equipment List and Description

Tag (Provided by Client)

Assortment	SKU	Description	
<b>C1252 SW GAL E8 3.75 Vehicle Class D</b>			
C1252AS00	C1252AS00	Vehicle	Tie Silencer
		Figure	Kylo Ren
<b>C1253 Star Wars BB-8 2-in-1 Mega Playset</b>			
C1253AS00	C1253AS00	BB-8 Mega Destroyer	Throne
			Trash Compactor
			Garrison Corridor
		Figure	Supreme Leader Snoke
		Figure	Elite Praetorian Guard
		Gauntlet (Force Link)	
<b>C1364 Star Wars Force Link Starter Set</b>			
C13640000	C13640000	Gauntlet (Force Link)	
		Figure	Kylo Ren
<b>C3553AV70 SW E8 FORCE LINK STARTER 2 PACK</b>			
C3553AV70	C3553AV70	Gauntlet (Force Link)	
		Figure	Tango Black
		Figure	Victor Guard 3
<b>C1503 SW GAL E8 FIGURE COLLECTION ORANGE AST WAVE 1</b>			
C1503AS00	C1504AS00	Figure	SW E8 SWU Foxtrot 1 Grey
	C1505AS00	Figure	SW E8 SWU Beta 1 Orange
	C1506AS00	Figure	SW E8 SWU Victor 1
	C1507AS00	Figure	SW E8 SWU Beta 2
	C1508AS00	Figure	SW E8 SWU Tango White
	C1509AS00	Figure	SW E8 SWU Cool Beta Grey
<b>C1531 SW GAL E8 FIGURE COLLECTION TEAL AST WAVE 1</b>			
C1531AS00	C1533AS00	Figure	SW E8 Victor 3
	C1534AS00	Figure	SW E8 SWU Foxtrot 2 Orange
	C1536AS00	Figure	SW SWU Cool Alpha 1
	C1537AS00	Figure	SW E8 SWU Delta 3
	C1538AS00	Figure	SW E8 Foxtrot 3
<b>C3801 SW GAL E8 FLAGSHIP SET WITHOUT FORCELINK</b>			
C3801AS00	C3801AS00	BB-8 Mega Destroyer	Throne
			Trash Compactor
			Garrison Corridor
		Figure	Supreme Leader Snoke
		Figure	Elite Praetorian Guard

## INTERTEK TESTING SERVICES

---

### 3.0 Emission Results

Data is included of the worst case configuration (the configuration which resulted in the highest emission levels). A sample calculation, configuration photographs and data tables of the emissions are included.

#### 3.1 Field Strength Calculation

The field strength is calculated by adding the Antenna Factor and Cable Factor, and subtracting the Amplifier Gain (if any), Average Factor (optional) from the measured reading. The basic equation with a sample calculation is as follows:

$$FS = RA + AF + CF - AG - AV$$

where

- FS = Field Strength in dB $\mu$ V/m
- RA = Receiver Amplitude (including preamplifier) in dB $\mu$ V
- CF = Cable Attenuation Factor in dB
- AF = Antenna Factor in dB
- AG = Amplifier Gain in dB
- AV = Average Factor in dB

In the following table(s), the reading shown on the data table reflects the preamplifier gain. An example for the calculations in the following table is as follows:

$$FS = RR + LF$$

where

- FS = Field Strength in dB $\mu$ V/m
- RR = RA - AG - AV in dB $\mu$ V
- LF = CF + AF in dB

Assume a receiver reading of 52.0 dB $\mu$ V is obtained. The antenna factor of 7.4 dB and cable factor of 1.6 dB are added. The amplifier gain of 29 dB and average factor of 5 dB are subtracted, giving a field strength of 27 dB $\mu$ V/m. This value in dB $\mu$ V/m was converted to its corresponding level in  $\mu$ V/m.

$$\begin{aligned} RA &= 52.0 \text{ dB}\mu\text{V/m} \\ AF &= 7.4 \text{ dB} & RR &= 18.0 \text{ dB}\mu\text{V} \\ CF &= 1.6 \text{ dB} & LF &= 9.0 \text{ dB} \\ AG &= 29.0 \text{ dB} \\ AV &= 5.0 \text{ dB} \\ FS &= RR + LF \\ FS &= 18 + 9 = 27 \text{ dB}\mu\text{V/m} \end{aligned}$$

$$\text{Level in } \mu\text{V/m} = \text{Common Antilogarithm } [(27 \text{ dB}\mu\text{V/m})/20] = 22.4 \mu\text{V/m}$$



## INTERTEK TESTING SERVICES

---

### 3.2 Radiated Emission Configuration Photograph

The worst case in radiated emission was found at 501.775 MHz

For electronic filing, the worst case radiated emission configuration photographs are saved with filename: radiated photos.pdf.

### 3.3 Radiated Emission Data

The data on the following page lists the significant emission frequencies, the limit and the margin of compliance. Numbers with a minus sign are below the limit.

Judgment: Passed by 5.0 dB

## INTERTEK TESTING SERVICES

Company: Hasbro Far East Ltd.

Date of Test: April 26, 2017

Model: C1364

Worst-Case Operating Mode: Transmitting

Table 1  
**Radiated Emissions**  
**Pursuant to FCC Part 15 Section 15.225 Requirement**

Polarization	Frequency (MHz)	Reading (dB $\mu$ V)	Pre-amp (dB)	Antenna Factor (dB)	Net at 3m (dB $\mu$ V/m)	Distance Factor (-dB)	Calculated at 30m (dB $\mu$ V/m)	Limit at 30m (dB $\mu$ V/m)	Margin (dB)
V	13.560	62.0	0	10.8	72.8	40.0	32.8	84.0	-51.2
V	27.120	27.9	0	9.5	37.4	40.0	-2.6	29.5	-32.1

Polarization	Frequency (MHz)	Reading (dB $\mu$ V)	Pre-Amp (dB)	Antenna Factor (dB)	Net at 3m (dB $\mu$ V/m)	Limit at 3m (dB $\mu$ V/m)	Margin (dB)
V	40.680	28.4	16	10.0	22.8	40.0	-17.2
V	54.240	30.2	16	11.0	25.5	40.0	-14.8
V	67.800	34.3	16	8.0	26.7	40.0	-13.3
H	81.360	29.1	16	7.0	20.4	40.0	-19.6
H	94.920	29.7	16	11.0	24.7	43.5	-18.8
<b>H</b>	<b>108.480</b>	<b>24.4</b>	<b>16</b>	<b>14.0</b>	<b>22.2</b>	<b>43.5</b>	<b>-21.3</b>
H	122.040	27.6	16	14.0	25.1	43.5	-18.4
<b>H</b>	<b>135.640</b>	<b>30.3</b>	<b>16</b>	<b>14.0</b>	<b>28.6</b>	<b>43.5</b>	<b>-14.9</b>
H	149.210	28.1	16	14.0	26.3	43.5	-17.2

- NOTES: 1. Peak Detector Data unless otherwise stated.
2. All measurements were made at 3 meters. Harmonic emissions not detected at the 3-meter distances were measured at 0.3-meter and an inverse proportional extrapolation was performed to compare the signal level to the 3-meter limit. No other harmonic emissions than those reported were detected at a test distance of 0.3-meter.
3. Negative sign in the column shows value below limit.
4. Loop antenna is used for the emissions below 30MHz.
5. Emission (the row indicated by **bold italic**) within the restricted band meets the requirement of FCC Part 15 Section 15.205.
6. Measurement Uncertainty is  $\pm 5.3$ dB at a level of confidence of 95%.

## INTERTEK TESTING SERVICES

Company: Hasbro Far East Ltd.  
Model: C1364  
Worst-Case Operating Mode: Transmitting

Date of Test: April 26, 2017

Table 2  
**Radiated Emissions**  
Pursuant to FCC Part 15 Section 15.209 Requirement

Polarization	Frequency (MHz)	Reading (dB $\mu$ V)	Pre-amp (dB)	Antenna Factor (dB)	Net at 3m (dB $\mu$ V/m)	Limit at 3m (dB $\mu$ V/m)	Margin (dB)
H	52.250	31.8	16	11.0	26.8	40.0	-13.2
<b>H</b>	<b>162.719</b>	<b>32.1</b>	<b>16</b>	<b>16.0</b>	<b>32.1</b>	<b>43.5</b>	<b>-11.4</b>
H	189.897	37.3	16	16.0	37.3	43.5	-6.2
H	197.209	37.7	16	16.0	37.7	43.5	-5.8
H	430.722	31.0	16	25.0	40.0	46.0	-6.0
H	474.597	28.3	16	26.0	38.3	46.0	-7.7
H	501.775	31.0	16	26.0	41.0	46.0	-5.0
H	528.831	27.1	16	27.0	38.1	46.0	-7.9

- NOTES: 1. Peak Detector Data unless otherwise stated.
2. All measurements were made at 3 meters. Harmonic emissions not detected at the 3-meter distances were measured at 0.3-meter and an inverse proportional extrapolation was performed to compare the signal level to the 3-meter limit. No other harmonic emissions than those reported were detected at a test distance of 0.3-meter.
3. Negative sign in the column shows value below limit.
4. Horn antenna is used for the emission over 1000MHz.
5. Emission (the row indicated by **bold italic**) within the restricted band meets the requirement of FCC Part 15 Section 15.205.
6. Measurement Uncertainty is  $\pm 5.3$ dB at a level of confidence of 95%.

## INTERTEK TESTING SERVICES

---

### 3.4 Frequency Stability

**FCC Part 15 Section 15.225**

**Data Table  
Frequency Deviation with Voltage Variation**

Operating frequency		13.560481MHz		
Test Voltage (V)	Temperature (°C)	Measured frequency (MHz)	Frequency error (%)	Limit (%)
4.5	+ 50	13.560452	-0.0002	±0.01
4.5	+ 40	13.560463	-0.0001	±0.01
4.5	+ 30	13.560472	-0.00007	±0.01
4.5	+ 20	13.560481	0	±0.01
4.5	+ 10	13.560504	+0.00017	±0.01
4.5	0	13.560512	+0.0002	±0.01
4.5	- 10	13.560547	+0.0005	±0.01
4.5	- 20	13.560556	+0.0006	±0.01

Nominal frequency Temperature (°C) Humidity (%)	Voltage	Frequency (MHz)	Frequency error (ppm)	Limite (ppm)	Result
25°C 50%	3.85	13.560479	-0.664	100	Pass
25°C 50%	4.5	13.560488	0	100	Pass
25°C 50%	4.95	13.560496	+0.590	100	Pass
Min -30°C 0%	3.85	13.560579	+6.711	100	Pass
Min -30°C 0%	4.5	13.560584	+7.079	100	Pass
Min -30°C 0%	4.95	13.560591	+7.596	100	Pass
Max 50°C 50%	3.85	13.560463	-1.844	100	Pass
Max 50°C 50%	4.5	13.560450	-2.802	100	Pass
Max 50°C 50%	4.95	13.560466	-1.622	100	Pass

Measurement Uncertainty is ±1.141Hz (13.56MHz) at a level of confidence of 95%.

## INTERTEK TESTING SERVICES

---

### 4.0 **Equipment Photographs**

For electronic filing, the photographs are saved with filename: external photos.pdf and internal photos.pdf.

### 5.0 **Product Labelling**

For electronics filing, the FCC ID label artwork and the label location are saved with filename: label.pdf.

### 6.0 **Technical Specifications**

For electronic filing, the block diagram and schematic of the tested EUT are saved with filename: block.pdf and circuit.pdf respectively.

### 7.0 **Instruction Manual**

For electronic filing, a preliminary copy of the Instruction Manual is saved with filename: manual.pdf.

This manual will be provided to the end-user with each unit sold/leased in the United States.

# INTERTEK TESTING SERVICES

## 8.0 Miscellaneous Information

The miscellaneous information includes details of the test procedure and measured bandwidth.

### 8.1 Measured Bandwidth

The plot saved in bw.pdf which shows the fundamental emission is confined in the specified band. The emission of the fundamental is 32.8dB $\mu$ V/m and it is below the limit of 50.5 dB $\mu$ V/m in the range of (13.410-13.553MHz) and (13.710-14.010MHz) and the limit of 40.5 dB $\mu$ V/m in the frequency range of (13.110-14.410MHz) and (13.710-14.010MHz). In the frequency range from 13.110-14.010MHz, we can not find any emission higher than the fundamental emission. Therefore they meet the requirement of Section 15.225(a), (b), (c), & (d).

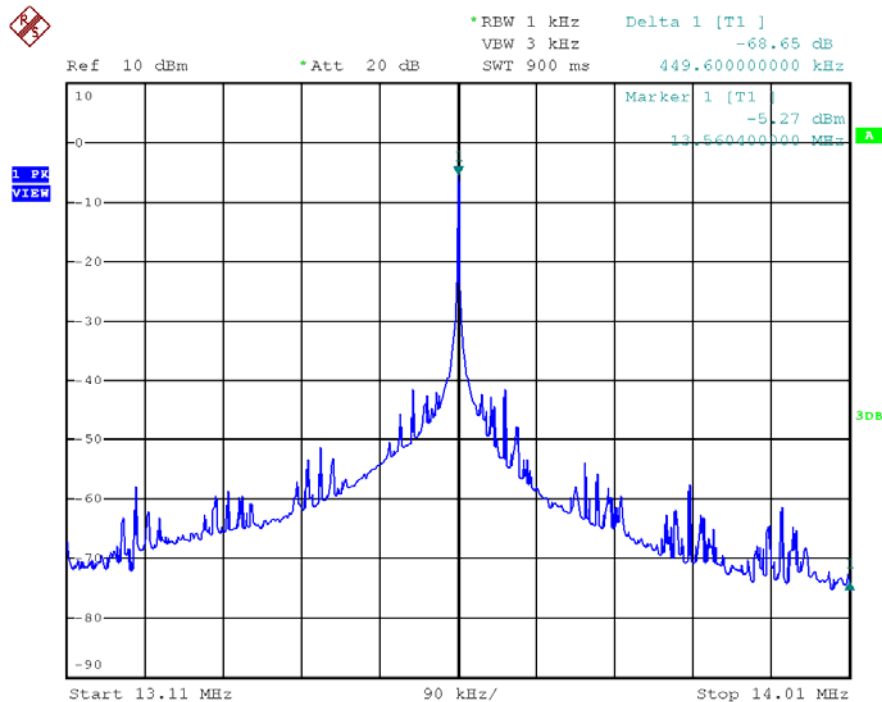

## INTERTEK TESTING SERVICES

---

### 8.2 Discussion of Pulse Desensitization

Pulse desensitivity is not applicable for this device. Since the transmitter transmits the RF signal continuously.

### 8.3 Calculation of Average Factor

The average factor is not applicable for this device as the transmitted signal is a continuously signal.

### 8.4 Emissions Test Procedures

The following is a description of the test procedure used by Intertek Testing Services Hong Kong Ltd. in the measurements of transmitter operating under the Part 15, Subpart C rules.

The transmitting equipment under test (EUT) is placed on a wooden turntable which is four feet in diameter and approximately 0.8m in height above the ground plane for emission measurement at or below 1GHz and 1.5m in height above the ground plane for emission measurement above 1GHz. During the radiated emissions test, the turntable is rotated and any cables leaving the EUT are manipulated to find the configuration resulting in maximum emissions. The EUT is adjusted through all three orthogonal axis to obtain maximum emission levels. The antenna height and polarization are also varied during the testing to search for maximum signal levels. The height of the antenna is varied from one to four meters.

Detector function for radiated emissions is in peak mode. Average readings, when required, are taken by measuring the duty cycle of the equipment under test and subtracting the corresponding amount in dB from the measured peak readings. A detailed description for the calculation of the average factor can be found in Exhibit 8.3.

The frequency range scanned is from the lowest radio frequency signal generated in the device which is greater than 9 kHz to the tenth harmonic of the highest fundamental frequency or 40 GHz, whichever is lower.

Detector function for radiated emissions is in peak mode. Average readings, when required, are taken by measuring the duty cycle of the equipment under test and subtracting the corresponding amount in dB from the measured peak readings.

The frequency range scanned is from 30 MHz to 1000 MHz.

## INTERTEK TESTING SERVICES

---

### 8.4 Emissions Test Procedures (cont'd)

The EUT is warmed up for 15 minutes prior to the test.

AC power to the unit is varied from 85% to 115% nominal and variation in the fundamental emission field strength is recorded. If battery powered, a new, fully charged battery is used.

Conducted measurements were made as described in ANSI C63.10 (2013).

The IF bandwidth used for measurement of radiated signal strength was 100 kHz or greater when frequency is below 1000 MHz. Where pulsed transmissions of short enough pulse duration warrant, a greater bandwidth is selected according to the recommendations of Hewlett Packard Application Note 150-2. A discussion of whether pulse desensitivity is applicable to this unit is included in this report (See Exhibit 8.1). Above 1000 MHz, a resolution bandwidth of 1 MHz is used.

Transmitter measurements are normally conducted at a measurement distance of three meters. However, to assure low enough noise floor in the forbidden bands and above 1 GHz, signals are acquired at a distance of one meter or less. All measurements are extrapolated to three meters using inverse scaling, unless otherwise reported. Measurements taken at a closer distance are so marked.



# INTERTEK TESTING SERVICES

## 8.4.1 Radiated Emission Test Setup

The figure below shows the test setup, which is utilized to make these measurements.

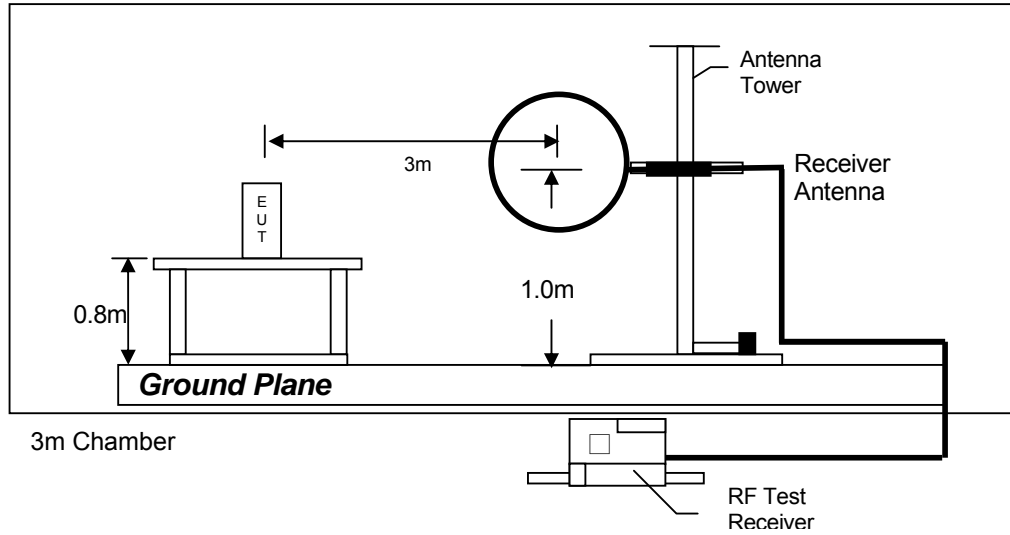

Test setup of radiated emissions up to 30MHz

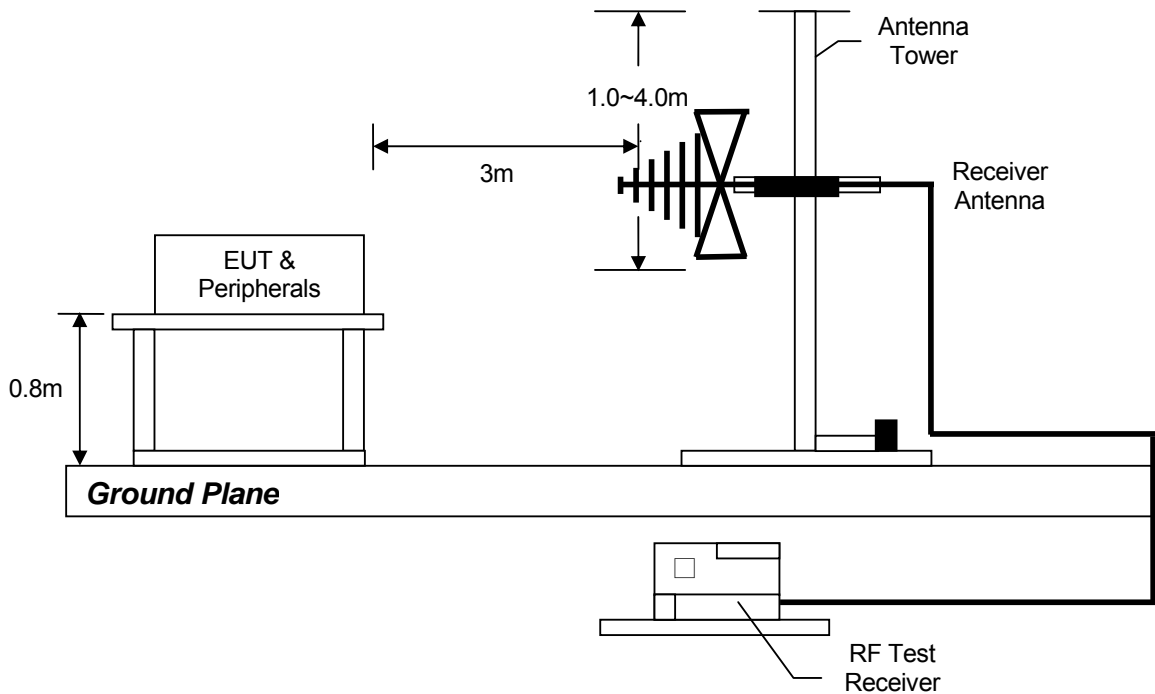

Test setup of radiated emissions from 30MHz to 1GHz

## INTERTEK TESTING SERVICES

### 9.0 Confidentiality Request

For electronic filing, a preliminary copy of the confidentiality request is saved with filename: request.pdf.

### 10.0 Equipment List

#### 1) Radiated Emissions Test

Equipment	EMI Test Receiver	Spectrum Analyzer	Biconical Antenna
Registration No.	EW-2666	EW-2253	EW-0571
Manufacturer	R&S	R&S	EMCO
Model No.	ESC17	FSP40	3104C
Calibration Date	Jun. 17, 2016	Jun. 15, 2016	May 18, 2016
Calibration Due Date	Jun. 17, 2017	Jun. 15, 2017	Nov. 18, 2017

Equipment	Active Loop H-field	Log Periodic Antenna
Registration No.	EW-2313	EW-0447
Manufacturer	ELETROMETRIC	EMCO
Model No.	EM-6876	3146
Calibration Date	Jun. 27, 2016	May. 18, 2016
Calibration Due Date	Dec. 27, 2017	Nov. 18, 2017

#### 2) Bandedge Measurement

Equipment	Spectrum Analyzer
Registration No.	EW-3016
Manufacturer	R&S
Model No.	FSV40
Calibration Date	Jun. 15, 2016
Calibration Due Date	Jun. 15, 2017

#### 3) Frequency Stability Measurement

Equipment	Spectrum Analyzer	Temperature & Humidity Chamber	Frequency Counter (up to 3GHz)
Registration No.	EW-3016	EW-2134	EW-2287
Manufacturer	R&S	GIANT FORCE	AGILENTTECH
Model No.	FSV40	GTH-750-40-CP-SD	53181A
Calibration Date	Jun. 15, 2016	Sep. 26, 2016	Jan. 12, 2017
Calibration Due Date	Jun. 15, 2017	Sep. 04, 2017	Nov. 17, 2017

END OF TEST REPORT