

Remark:

- 1).All electrolytic capacitors are 16V or above, ±20% except specified .
- 2).All ceramic capacitors are 12V or above , ±20% except specified .
- 3).All resistors are ±5% except specified .
- 4).In PCB layout , the trace separation between all VCCs and GND should be minimum 2.0mm .
- 5).The surrounding area of all Fuse/polyswitch should be free of traces within 2.0mm of the component .
- 6).* Means adjusted by Factory.
- 7).** The parts is close to IC as possible.

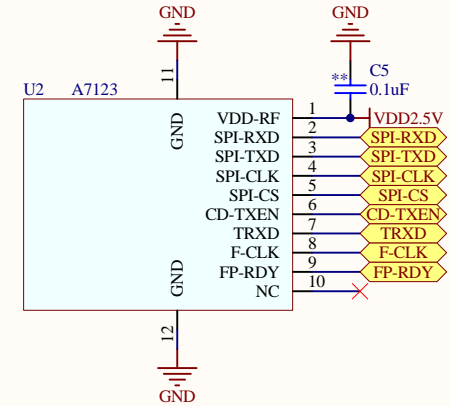
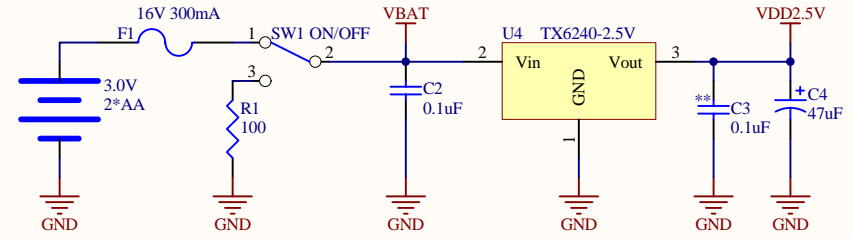
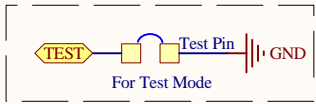
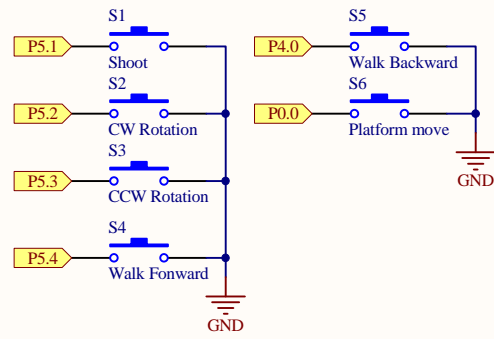
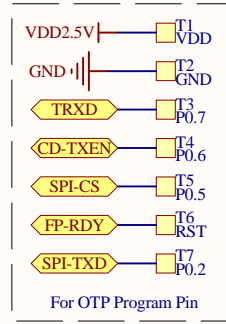
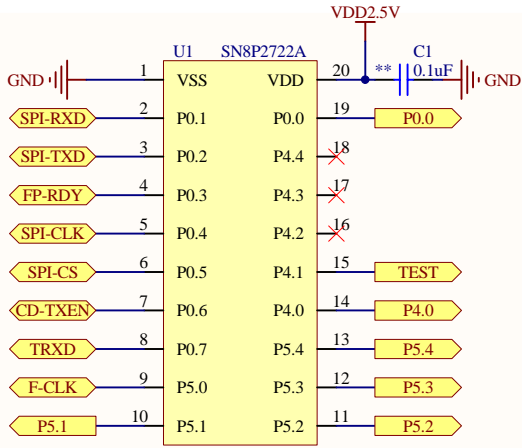

Assortment # :325565	Product Name :Ner Combat Creature
Material # :A80170000	Revision : V1
Drawn By :	Sheet 1 of 1
Schematic # :S325565	BOM # : B325565 IC # : SN8P2722A
Engineer : Roy	Checked : Approved :
DWG No. :DWG-325565_D010_R01	File Name : 325565_Schematic
HASBRO INC .	

REVISION HISTORY
1 Final release for production

BY	DATE
	2 MAY 2014



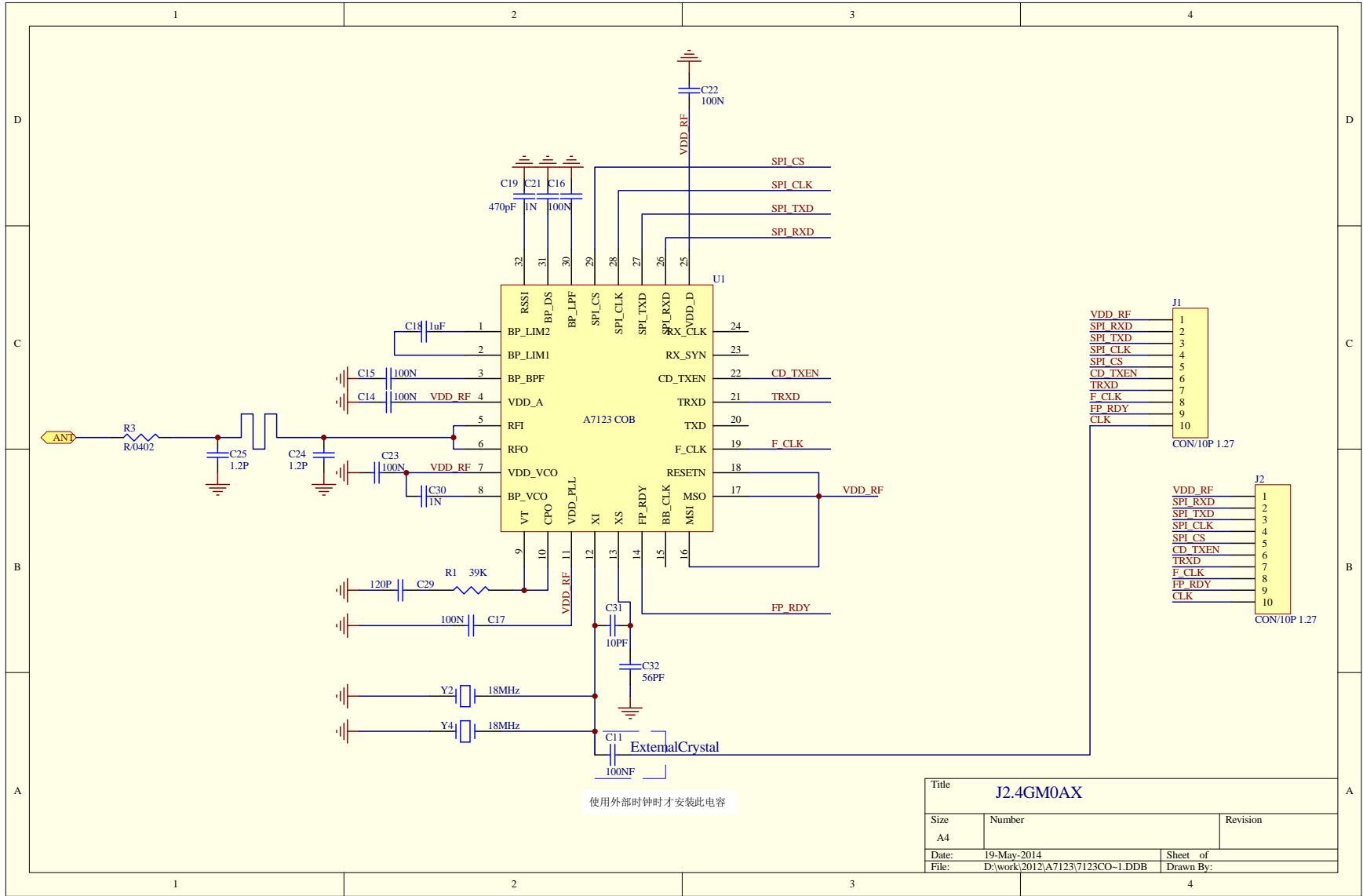

Title		
J2.4GM0AX		
Size	Number	Revision
A4		
Date:	19-May-2014	Sheet of
File:	D:\work\2012\A7123\7123CO-1.DDB	Drawn By: