

FCC ID: RS4-42790

Technical Description :

The brief circuit description is listed as follows :

- CON and CON1 act as Loop Antennas.
- Q1, K1 and associated circuit act as Relay.
- Q2 and associated circuit act as RF Output Amplifier.
- U2 (W55MID50), Y1 and associated circuit act as 13.56 MHz RFID Reader.
- U1 (W588S060) acts as MCU with Voice Synthesizer.
- U4 and associated circuit act as Voltage Regulator (3.6V).
- U3 acts as Audio Amplifier.

Antenna Used :

Two loop antennas have been used.



1. GENERAL DESCRIPTION

Winbond *MFID^{WB}* (Magnetic Field Identification) series is used in all areas of automatic data capture allowing contactless identification of objects using magnetic field. From ticketing to industrial automation and access control, the applications of MFID are burgeoning. In recent years automatic identification procedures have become very popular in many service industries, purchasing and distribution logistics, industry, manufacturing companies and material flow systems.

W55MID50 is one of series in Winbond *MFID^{WB}* family that supports multi-functional Reader solution and especially focus on toy, security, and consumer related applications. The applications with Winbond *MFID^{WB}* Tag series such as W55MID10 that provides read-only mask ROM-ID version transponder for mass production solution in toy industrial, meanwhile W55MID15 provides the other solution for manufacture option, which is 243 bonding-ID selection transponder. Besides the single tag transponder application, W55MID35 offers multi-transponder recognition function for intelligent and smart toy applications.

W55MID50 provides a wide variety of applications for toy, security, and consumer market meanwhile the W55MID50 is the most cost effective solution on current *MFID^{WB}* related application market

2. FEATURES

- Magnetic field resonance frequency: 13.56 MHz
- Data clock: 22 ~ 66KHz
- Inductive coupled power supplies for transponder's no battery operation
- On-chip rectifier, voltage limiter, clock extraction, power management, μ C interface
- Provides NRZ and Manchester coding data format
- Adjustable 4-level of Reader transmission power selection
- Provides serial and parallel mode μ C interface
- μ C data output rate \geq 1Mbps
- Low power, low voltage operation
- Supports power-down mode \leq 1 μ A
- Operating distance: 0 ~ 10cm
- Operating voltage: 2.4V ~ 5.5V
- Operating temperature: 0 ~ 70 °C
- Package: Dice form, PDIP-20, SOP-20
- Reference design PC board Size: 2.0 x 2.0cm² (without PCB antenna)
- Winbond patented "Automatic Reader Transmission Power Adjustment" for Reader optimum transmission power adjust
- Minimize external components



4. BLOCK DIAGRAM

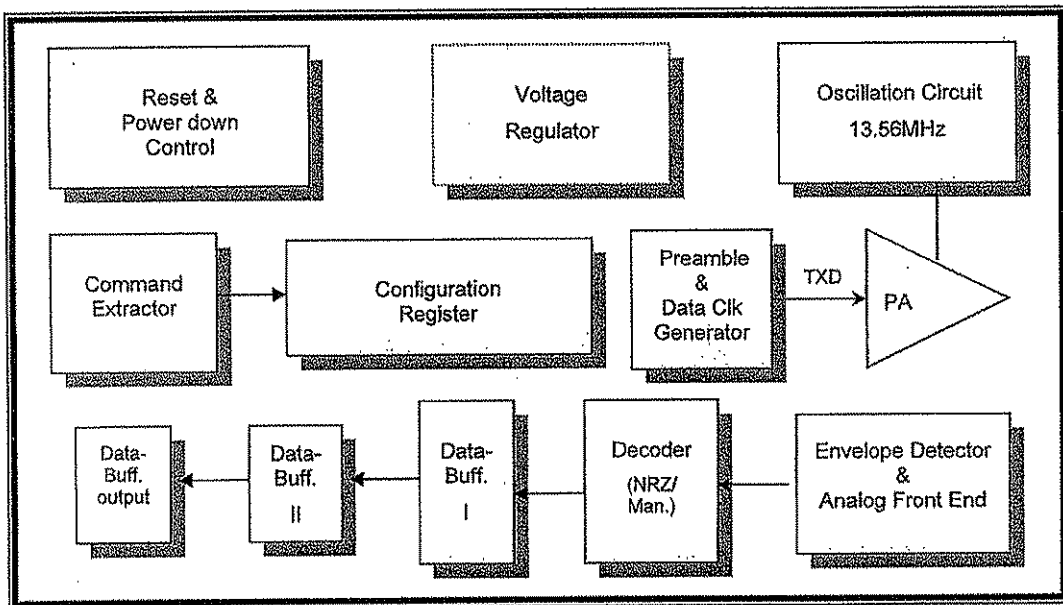



5. FUNCTIONAL DESCRIPTION

5.1 Transmission Power Amplifier (PA)

It provides 4 different selectable transmission power for Reader chip to support *MFID^{WB}* Tag's radiation power supply. The external inductor coupling circuit is designed for 13.56MHz magnetic field resonance. The coupled center frequency will depend on equivalent value of external PCB inductor and capacitor.

5.2 Envelope Detector & Analog Front End

The major function of this unit provides *MFID^{WB}* Tag's data can be extracted.

5.3 Voltage Regulator

The voltage regulator generates the system needs of device power supply.

5.4 Configuration Register

System configuration register controls the all functional settings of W55MID50 such as Tag data format, Tag detection cycle, output data format, and PA transmission power selection.

5.5 Reset and Power-down Control

The function of system power-down control mode is normally used for power consumption saving.

5.6 Crystal Oscillation

The 13.56MHz system clock generator generates the need of device system clock.

5.7 Decoder NRZ/Manchester

This unit is in charge of Tag data format decoder, which can provide Tag-ID data format decoding of NRZ or Manchester.

5.8 Data Buffer and Output

This unit buffers the Tag-ID data, which is under de-frame processing.



1. GENERAL DESCRIPTION

The W588Sxxx is a powerful microcontroller-based speech synthesizer with 3 channels of speech and melody for multi-tasking applications.

The W588Sxxx provides slow mode operation and PWM output to help reduce the power consumption for longer battery life. Also, the W588Sxxx adopts the MDPCM, ADPCM or PCM algorithm to reproduce high quality sound outputs.

Other powerful functions like IR carrier generation and event synchronization mechanism are provided to meet the requirements for more complicated multi-tasking applications.

The W588Sxxx family contains several items with different playback duration as shown below: (@5-bit MDPCM algorithm, 6KHz sampling rate)

ITEM	W588S003	W588S006	W588S010	W588S013	W588S016
*Duration	4 sec.	7 sec.	12 sec.	16 sec.	20 sec.
ITEM	W588S020	W588S025	W588S030	W588S040	W588S050
Duration	25 sec.	29 sec.	32 sec.	50 sec.	58 sec.
ITEM	W588S060	W588S080	W588S100	W588S120	-
Duration	66 sec.	100 sec.	118 sec.	133 sec.	-

**ITEM	W588S009	W588S012	W588S015
Duration	12 sec.	16 sec.	20 sec.

Note:

*: The duration time is based on 5-bit MDPCM at 6 KHz sampling rate. The firmware library and program code have been excluded from user's ROM space for the duration estimation.

** : W588S009, S012 and S015 are a little different in RAM and I/O definition. Meanwhile, *PowerScript*™ dose not support either.



2. FEATURES

- Wide Operating voltage: 2.4 ~ 5.5 volt
- Build in 8-bit MCU core with powerful programmable capability
- System clock
 - 4 MHz at 2.4 ~ 5.5 volt
 - 8 MHz at 3.6 ~ 5.5 volt
- F/W speech synthesis
 - 5-bit MDPCM, 4-bit ADPCM or 8-bit PCM algorithm can be used
 - Programmable sample rate
- Direct-drive PWM output to save power consumption (no support in W588S003 and W588S006)
- Built-in 3 timers for speech/melody synthesis and general purpose applications
 - 2 speech channels
 - 1 speech channel plus dual-tone melody
 - 2 voice melody channels
- Build in on-chip mixer
- Built-in 32 KHz crystal oscillator with divider for time-keeping application
- Provide Watch Dog Timer (WDT)
- Provide power management to save current consumption:
 - 4 ~ 8 MHz system clock, with Ring type oscillator
 - Slow mode to reduce power
 - Stop mode for stopping all IC operations
- I/O configuration
 - W588S003 ~ W588S120: 16 I/O
 - W588S009, W588S012, W588S015: 4 In, 8 I/O, 4 Out
- Shared ROM for voice, melody and program storage
- Provide IR carrier generation
- Built-in Serial Interface Manager (SIM) in W588S080 ~ W588S120
- Support **PowerScript™** for developing codes in easy way. (No support in W588S009, S012, and S015)
- Full-fledged development system
 - Source-level ICE debugger (Assembly & **PowerScript™** format)
 - Event synchronization mechanism
 - Compatible with W566B/C & W567S system
 - User-friendly GUI environment
- Available package form:
 - COB is essential
 - W588S003 ~ W588S120: LQFP48
 - W588S009, S012, S015: QFP44



4. BLOCK DIAGRAM

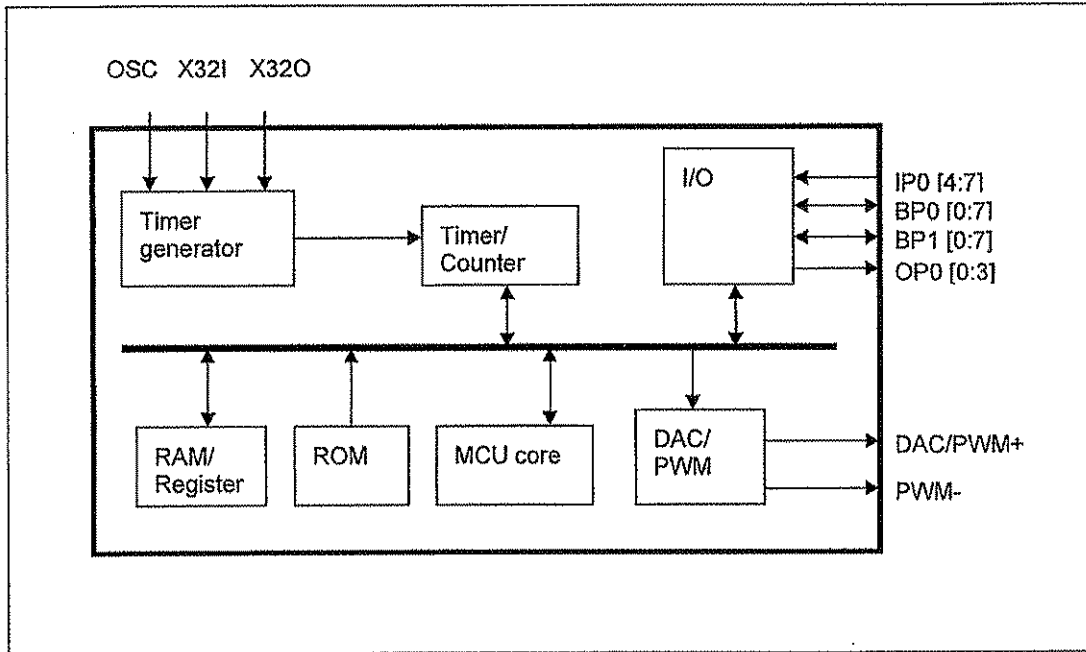

Notes:

1. IP0 and OP0 are only providing in W588S009, W588S012 and W588S015.
2. BP1 is no providing in W588S009, W588S012 and W588S015.
3. PWM is no providing in W588S003 and W588S006.

5. ELECTRICAL CHARACTERISTICS

5.1 Absolute maximum ratings

PARAMETER	SYMBOL	CONDITIONS	RATED VALUE	UNIT
Power Supply	VDD-VSS	-	-0.3 to +7.0	V
Input Voltage	VIN	All Inputs	Vss -0.3 to VDD +0.3	V
Storage Temp.	TSTG	-	-55 to +150	°C
Operating Temp.	TOPR	-	0 to +70	°C

Note: Exposure to conditions beyond those listed under Absolute Maximum Ratings may adversely affect the life and reliability of the device.