

FCC PART 15 ID
EMI MEASUREMENT AND TEST REPORT

For

Shanghai Dare Technologies Co., Ltd

22 F Shanghai Information Building
No. 1555 KongJiang Road, Shanghai, China

FCC ID: RS3DB108

2004-01-16

This Report Concerns: <input checked="" type="checkbox"/> Original Report	Equipment Type: ADSL Modem - ITE
Test Engineer: Hang Tan	
Report No.: R0312222	
Test Date: 2003-12-22	
Reviewed By: Jerry Wang	
Prepared By: Bay Area Compliance Laboratory Corporation (BACL) 230 Commercial Street Sunnyvale, CA 94085 Tel: (408) 732-9162 Fax: (408) 732-9164	

Note: This test report is specially limited to the use of the above client company and the product model only. It may not be duplicated without prior written consent of Bay Area Compliance Laboratory Corporation. This report **must not** be used by the client to claim product Endorsement by NVLAP or any agency of the U.S. Government.

TABLE OF CONTENTS

GENERAL INFORMATION	3
PRODUCT DESCRIPTION FOR EQUIPMENT UNDER TEST (EUT)	3
OBJECTIVE.....	3
RELATED SUBMITTAL(S)/GRANT(S)	3
TEST METHODOLOGY	3
TEST FACILITY.....	3
LOCAL SUPPORT EQUIPMENT LIST AND DETAILS	4
EXTERNAL I/O CABLING LIST AND DETAILS.....	4
SYSTEM TEST CONFIGURATION.....	5
JUSTIFICATION.....	5
EUT EXERCISE SOFTWARE.....	5
SPECIAL ACCESSORIES	5
SCHEMATICS / BLOCK DIAGRAM.....	5
EQUIPMENT MODIFICATIONS.....	5
CONFIGURATION OF TEST SYSTEM.....	6
TEST SETUP BLOCK DIAGRAM.....	6
§15.107 - CONDUCTED EMISSIONS	7
MEASUREMENT UNCERTAINTY.....	7
EUT SETUP.....	7
SPECTRUM ANALYZER SETUP	7
TEST EQUIPMENT LIST AND DETAILS.....	7
TEST PROCEDURE.....	7
ENVIRONMENTAL CONDITIONS.....	8
TEST RESULTS SUMMARY.....	8
CONDUCTED EMISSIONS TEST DATA.....	8
PLOTS OF CONDUCTED EMISSION	8
§15.109 - RADIATED EMISSIONS	11
MEASUREMENT UNCERTAINTY.....	11
EUT SETUP.....	11
SPECTRUM ANALYZER SETUP	11
TEST EQUIPMENT LIST AND DETAILS.....	12
TEST PROCEDURE.....	12
CORRECTED AMPLITUDE & MARGIN CALCULATION	12
SUMMARY OF TEST RESULTS.....	12
RADIATED EMISSIONS TEST DATA.....	13

GENERAL INFORMATION

Product Description for Equipment Under Test (EUT)

The *Shanghai Dare Technologies Co., Ltd's* product, model DB108 or the "EUT" as referred to in this report is the ADSL Modem which measures approximately 5.5"L x 5.25"W x 1.25"H.

The EUT provides the following port(s) and connector(s):

- One DC Power connector (2 Pin)
- One Phone Line connector (2 Pin)
- One Ethernet Line connector (8 Pin)

**The test data gathered are from production sample, serial number: DB10801, provided by the manufacturer.*

Objective

This test report is prepared on behalf of *Shanghai Dare Technologies Co., Ltd.* in accordance with Part 2, Subpart J, and Part 15, Subparts A and B of the Federal Communication Commissions rules and regulations and to ICES-003 of the Canadian Interference-Causing Equipment Regulations.

The objective is to determine compliance with FCC Class B limits for Information Technology Equipment.

Related Submittal(s)/Grant(s)

No Related Submittals.

Test Methodology

All measurements contained in this report were conducted with ANSI C63.4-2001, American National Standard for Methods of Measurement of Radio-Noise Emissions from Low-Voltage Electrical and Electronic Equipment in the range of 9 kHz to 40 GHz.

All radiated and conducted emissions measurements were performed at BACL. The radiated testing was performed at an antenna-to-EUT distance of 3 Meters.

Test Facility

The Open Area Test site used by BACL to collect radiated and conducted emission measurement data is located in the back parking lot of the building at 230 Commercial Street, Sunnyvale, California, USA.

Test site at BACL has been fully described in reports submitted to the Federal Communication Commission (FCC) and Voluntary Control Council for Interference (VCCI). The details of these reports has been found to be in compliance with the requirements of Section 2.948 of the FCC Rules on February 11 and December 10, 1997 and Article 8 of the VCCI regulations on December 25, 1997. The facility also complies with the radiated and AC line conducted test site criteria set forth in ANSI C63.4-2001.

The Federal Communications Commission and Voluntary Control Council for Interference has the reports on file and is listed under FCC file 31040/SIT 1300F2 and VCCI Registration No.: C-1298 and R-1234.

The test site has been approved by the FCC and VCCI for public use and is listed in the FCC Public Access Link (PAL) database.

Additionally, BACL is a National Institute of Standards and Technology (NIST) accredited laboratory, under the National Voluntary Laboratory Accredited Program (Lab Code 200167-0). The scope of the accreditation covers the FCC Method - 47 CFR Part 15 - Digital Devices, CISPR 22: 1997: Electromagnetic Interference - Limits and Methods of Measurement of Information Technology Equipment test methods under NVLAP Lab Code 200167-0.

Local Support Equipment List and Details

Manufacturer	Description	Model	Serial Number	FCC ID
Compaq	Tower PC	PD1000	6914CJBPA326	DOC
KDS	Monitor	KDS-7311	0891265478	EVOKD-1731
Behavior Tech	Keyboard	9113	6009300397	E5XKB9113
Logitech	Mouse	M-CAA42	LZE02062842	DOC
HP	Printer	Thinkjet 2225C	2512S43681	BS46XU2225C
Everex	Modem	Evercom 24E (EV945)	N/A	E3E5UVEV-945

Remote Support Equipment

Manufacturer	Description	Model	Serial Number	FCC ID
Arescom	DSL Simulator	CDS6020	B102903	DOC

Printed Circuit Boards in EUT

Manufacturer/Description	Rev.	# of Layers	Crystals (MHz)
Shanghai Dare	A	4	17.28 / 25

External I/O Cabling List and Details

Cable Description	Length (M)	Port/From	To
Shielded KB Cable	1.6	KB/Host	Generic Keyboard
Shielded Cable	1.5	Mouse Port/Host	Logitech Mouse
Shielded Serial Cable	1.5	Serial /Host	EVEREX Modem
Shielded Printer Cable	1.5	Parallel/Host	HP Printer
Shielded Video Cable	1.8	VGA /Host	KDS Monitor
Phone Line	50	Line /EUT	Arescom DSL Simulator
LAN Cable	1.5	LAN Port/EUT	Compaq PC

SYSTEM TEST CONFIGURATION

Justification

The system was configured for testing according to ANSI C63.4-2001.

EUT Exercise Software

The EUT exercising program used during radiated and conducted testing was designed to exercise the various system components.

Special Accessories

As shown in test setup block diagram, interface cable used for compliance testing are shielded and supplied by applicant and/or its respective support equipment manufacturers.

Schematics / Block Diagram

Please refer to Exhibit C.

Equipment Modifications

No modifications were made to the EUT.

Configuration of Test System

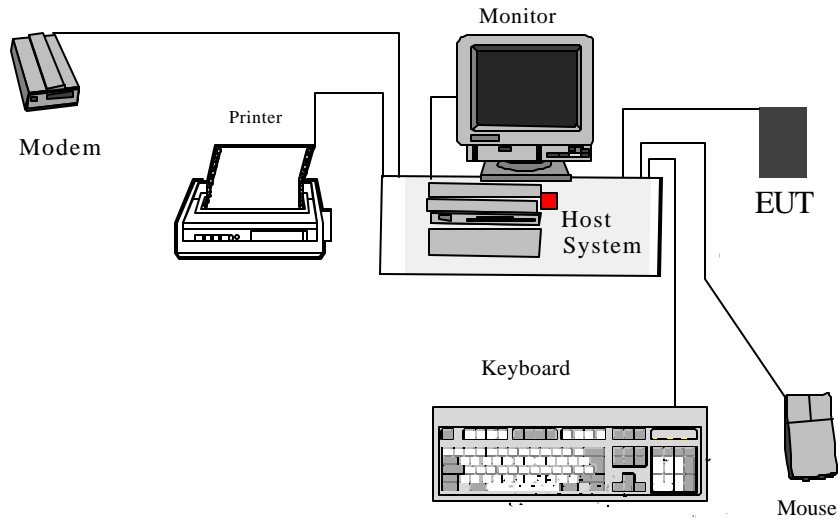

Test Setup Block Diagram

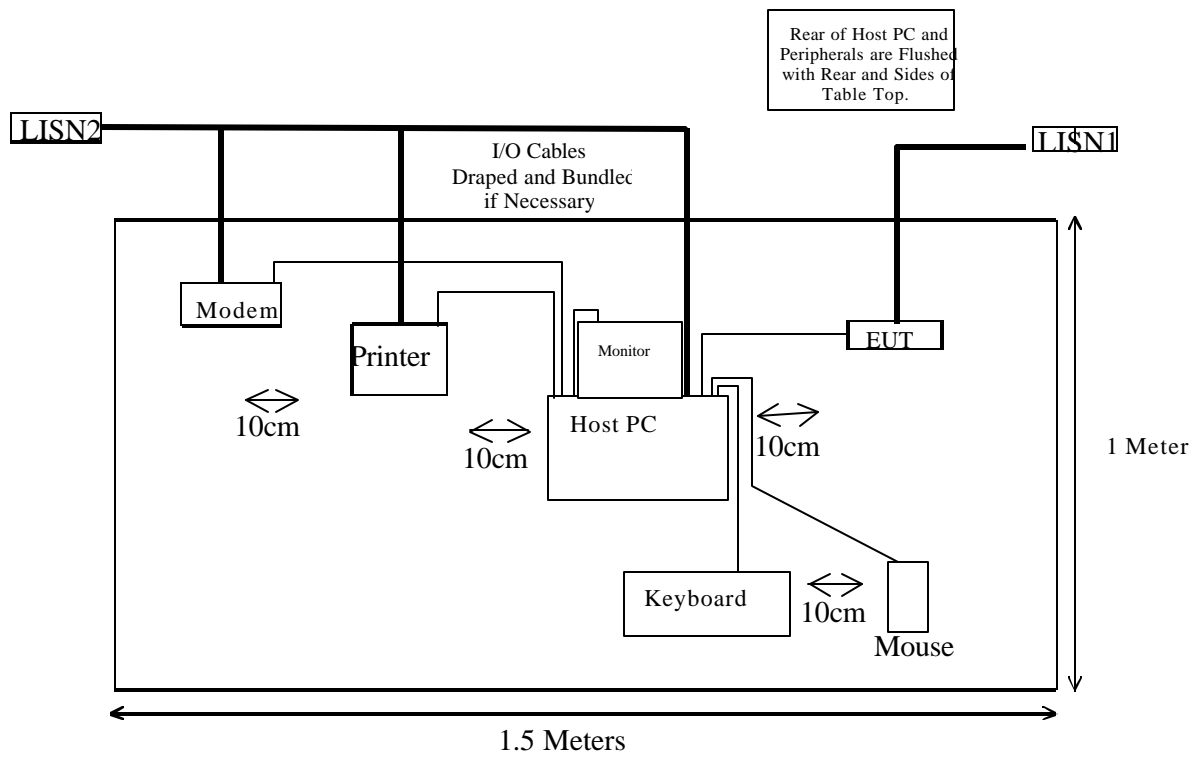

§15.107 - CONDUCTED EMISSIONS

Measurement Uncertainty

All measurements involve certain levels of uncertainties, especially in field of EMC. The factors contributing to uncertainties are spectrum analyzer, cable loss, and LISN.

Based on NIS 81, The Treatment of Uncertainty in EMC Measurements, the best estimate of the uncertainty of any conducted emissions measurement at BACL is ± 2.4 dB.

EUT Setup

The measurement was performed in the shield room, using the same setup per ANSI C63.4-2001 measurement procedure. The specification used was the FCC15 Class B limits.

The spacing between the peripherals was 10 cm.

The external I/O cables were draped along the test table and bundled as required.

The host PC was connected to 120Vac/60Hz power source.

Spectrum Analyzer Setup

The spectrum analyzer was set to investigate the spectrum from 150 kHz to 30Mhz.

Test Equipment List and Details

Manufacturer	Description	Model	Serial Number	Cal Date
Rohde & Schwarz	Artificial LISN	ESH2-Z5	871884/039	2003-03-28
Rohde & Schwarz	EMI Test Receiver	ESCS30	100176	2003-05-06

* **Statement of Traceability: BACL Corp.** certifies that all calibrations have been performed in accordance to NVLAP requirements, traceable to the NIST.

Test Procedure

During the conducted emission test, the power cord of the host system was connected to the auxiliary outlet of the first LISN.

Maximizing procedure were performed on the six (6) highest emissions of the EUT.

All data was recorded in the peak detection mode, quasi-peak and average. Average readings are distinguished with an "Ave". Quasi-peak readings are distinguished with an "Qp".

Environmental Conditions

Temperature:	13 ° C
Relative Humidity:	50%
ATM Pressure:	1027 mbar

Test Results Summary

According to the recorded data in following table, the EUT complied with the FCC Conducted limits for a Class B device, with the worst margin reading of:

-16.8 dB at **1.16 MHz** in the **Neutral** conductor.

Conducted Emissions Test Data

LINE CONDUCTED EMISSIONS				FCC 15 CLASS B	
Frequency	Amplitude	Detector	Phase	Limit	Margin
MHz	dB μ V	Qp/Ave/Peak	Line/Neutral	dB μ V	dB
1.160	39.2	QP	Neutral	56.00	-16.8
1.080	36.3	QP	Line	56.00	-19.7
0.150	45.0	QP	Neutral	66.00	-21.0
0.150	43.8	QP	Line	66.00	-22.2
8.100	27.1	Ave	Line	50.00	-22.9
8.100	23.8	Ave	Neutral	50.00	-26.2
8.100	31.1	QP	Line	60.00	-28.9
1.160	16.4	Ave	Neutral	46.00	-29.6
8.100	29.1	QP	Neutral	60.00	-30.9
1.080	15.1	Ave	Line	46.00	-30.9
0.150	16.6	Ave	Neutral	56.00	-39.4
0.150	15.2	Ave	Line	56.00	-40.8

Plots of Conducted Emission

The plots of conducted emission are presented hereinafter as reference.

Bay Area Compliance Laboratory Corp
Class B

23. Dec 03 18:35

EUT: DB108
Manuf: Shanghai Dare
Op Cond: Normal
Operator: Hang
Comment: L

Hang
2003-12-23

Scan Settings (3 Ranges)

Frequencies			Receiver Settings					
Start	Stop	Step	IF BW	Detector	M-Time	Atten	Preamp	
150k	1M	5k	9k	QP+AV	20ms	15dB LN	OFF	
1M	5M	10k	9k	QP+AV	1ms	15dB LN	OFF	
5M	30M	100k	9k	QP+AV	1ms	15dB LN	OFF	

Final Measurement: x QP / + AV
 Meas Time: 1 s
 Subranges: 28
 Acc Margin: 6dB

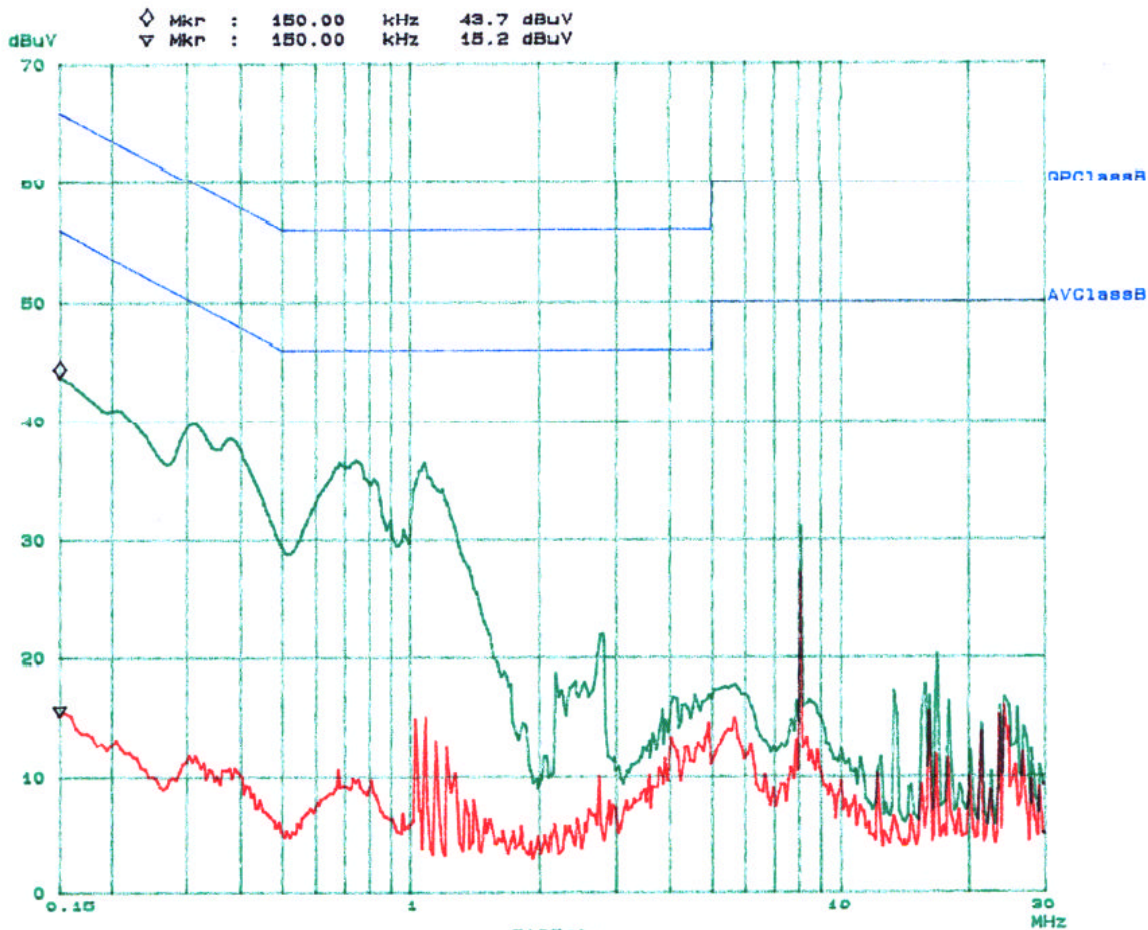

Bay Area Compliance Laboratory Corp
Class B

23. Dec 03 18:18

EUT: DB108
Manuf: Shanghai Dare
Op Cond: Normal
Operator: Hang
Comment: N

Handwritten: He
2003-12-23

Scan Settings (3 Ranges)

Frequencies			Receiver Settings			
Start	Stop	Step	IF BW	Detector	M-Time	Atten Preamp
150k	1M	5k	9k	QP+AV	20ms	15dB LN OFF
1M	5M	10k	9k	QP+AV	1ms	15dB LN OFF
5M	30M	100k	9k	QP+AV	1ms	15dB LN OFF

Final Measurement: x QP / + AV
Meas Time: 1 s
Subranges: 25
Acc Margin: 6dB

◇ Mkr : 150.00 kHz 44.9 dBuV
▽ Mkr : 150.00 kHz 16.6 dBuV

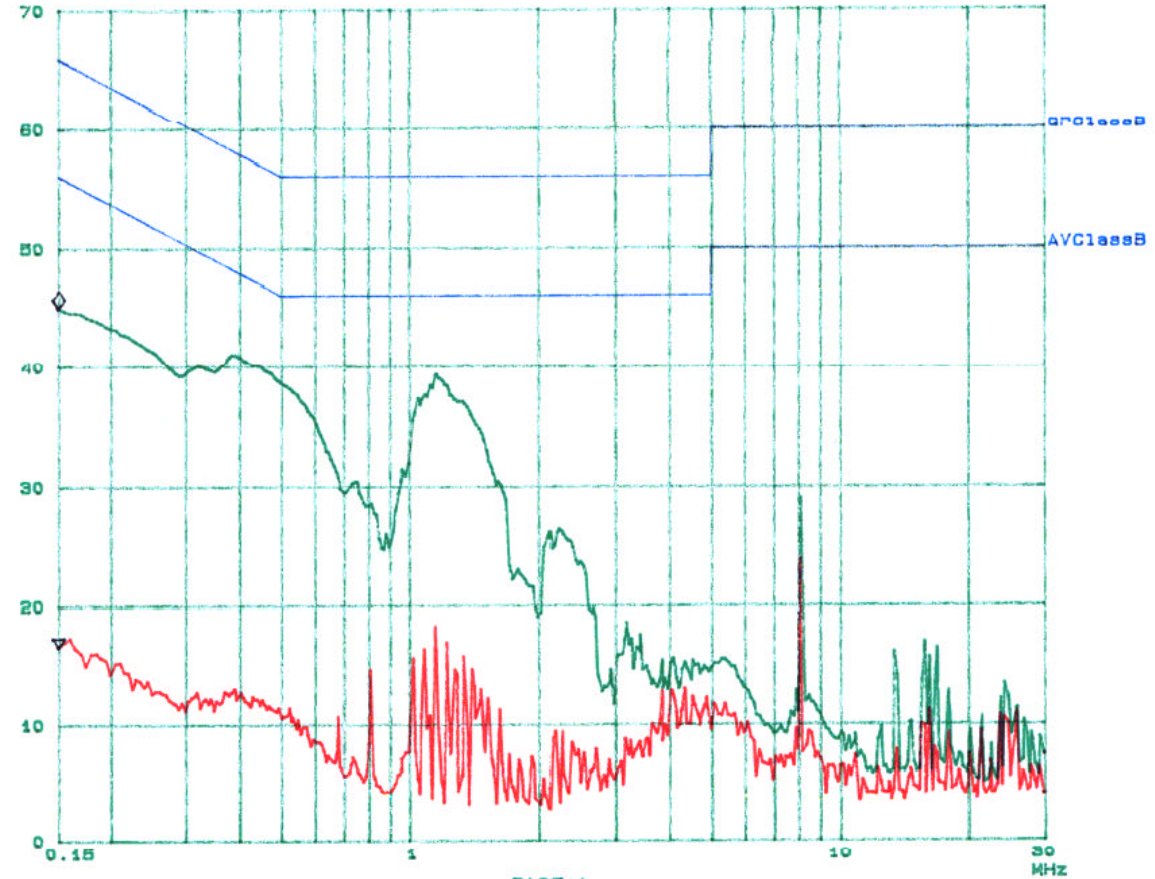

PAGE 1

§15.109 - RADIATED EMISSIONS

Measurement Uncertainty

All measurements involve certain levels of uncertainties, especially in the field of EMC. The factors contributing to uncertainties are spectrum analyzer, cable loss, antenna factor calibration, antenna directivity, antenna factor variation with height, antenna phase center variation, antenna factor frequency interpolation, measurement distance variation, site imperfections, mismatch (average), and system repeatability.

Based on NIS 81, The Treatment of Uncertainty in EMC Measurements, the best estimate of the uncertainty of a radiation emissions measurement at BAACL is ± 4.0 dB.

EUT Setup

The radiated emission tests were performed in the open area 10-meter test site, using the setup in accordance with ANSI C63.4-2001. The specification used in this report was the FCC Part 15 ID.

The spacing between the peripherals was 10 cm.

The external I/O cables were draped along the test table and bundled as required.

The host PC was connected to 120Vac/60Hz power source.

Spectrum Analyzer Setup

The system was tested to 1000 MHz.

During the radiated emission test, the spectrum analyzer was set with the following configurations:

<i>Frequency Range</i>	<i>RBW</i>	<i>Video B/W</i>
Below 30MHz	10kHz	10kHz
30 – 1000MHz	100kHz	100kHz
Above 1000MHz	1MHz	1MHz

Test Equipment List and Details

Manufacturer	Description	Model	Serial Number	Cal Date
HP	Spectrum Analyzer	8568B	2601A02165	2003-06-13
HP	Spectrum Analyzer Display	85662A	3026A20081	2003-06-13
HP	Quasi-Peak Adapter	85650A	3019A05393	2003-09-30
Agilent	Amplifier	8447D	2944A10187	2003-09-23
Electro-Metrics	Biconical Antenna	EM-6912	585	2003-04-17
Electro-Metrics	Logperiodic Antenna	EM-6950	788	2003-04-15

* **Statement of Traceability: BACL Corp.** certifies that all calibrations have been performed in accordance to NVLAP requirements, traceable to the NIST.

Test Procedure

For the radiated emissions test, the power cord of the host system and all support equipment were connected to the AC floor outlet.

Maximizing procedure was performed on the six (6) highest emissions in the described configurations.

All data was recorded in the peak detection mode. Quasi-peak readings was performed only when an emission was found to be marginal (within -4 dB μ V of specification limits), and are distinguished with a "Qp" in the data table.

Corrected Amplitude & Margin Calculation

The Corrected Amplitude is calculated by adding the Antenna Factor and Cable Factor, and subtracting the Amplifier Gain from the Amplitude reading. The basic equation is as follows:

$$\text{Corr. Ampl.} = \text{Indicated Reading} + \text{Antenna Factor} + \text{Cable Factor} - \text{Amplifier Gain}$$

The "**Margin**" column of the following data tables indicates the degree of compliance with the applicable limit. For example, a margin of -7dB μ V means the emission is 7dB μ V below the maximum limit for Class B. The equation for margin calculation is as follows:

$$\text{Margin} = \text{Corr. Ampl.} - \text{Class B Limit}$$

Summary of Test Results

According to the data in following tables, the EUT complied with the FCC 15 Class B standards, and had the worst margin of:

-2.5 dB at 500.04 MHz in the **Horizontal** polarization.

Testing performed by Hang Tan on 2003-12-22, originally saved on server.

Radiated Emissions Test Data**Environmental Conditions**

Temperature:	13 °C
Relative Humidity:	50%
ATM Pressure:	1027bar

Final Test Data for Normal (Native) Operating Mode, 30 to1000 MHz, 3Meters.

INDICATED		TABLE	ANTENNA		CORRECTION FACTOR			CORRECTED AMPLITUDE	FCC 15 CLASS B	
Frequency MHz	Ampl. dBmV/m	Angle Degree	Height Meter	Polar H/ V	Antenna dBmV/m	Cable dB	Amp. dB	Corr. Ampl. dBmV/m	Limit dBmV/m	Margin dB
500.04	51.9	120	1.7	H	18.5	1.7	28.6	43.5	46	-2.50
250.01	55.3	150	2.5	H	11.7	1.2	27.5	40.7	46	-5.30
132.48	52.6	225	1.3	V	12.6	0.8	28.1	38.0	43.5	-5.60
75.31	51.9	60	2.5	V	9.50	0.7	28.4	33.7	40	-6.30
75.32	50.5	90	2.0	H	9.50	0.7	28.4	32.3	40	-7.70
500.10	45.6	150	1.8	V	18.5	1.7	28.6	37.2	46	-8.80
250.02	50.4	180	2.8	V	11.7	1.2	27.5	35.8	46	-10.3
132.48	47.5	45	3.8	H	12.6	0.8	28.1	32.9	43.5	-10.7
120.59	46.1	0	1.8	H	12.1	0.8	28.3	30.7	43.5	-12.8
120.61	45.4	45	2.5	V	12.1	0.8	28.3	30.0	43.5	-13.5