

FCC PART 15

EMI MEASUREMENT AND TEST REPORT

For

Shanghai Dare Technologies Co., Ltd

22 F Shanghai Information Building
No. 1555 KongJiang Road, Shanghai, China

FCC ID: RS3DB108-WL

2004-02-21

This Report Concerns: <input checked="" type="checkbox"/> Original Report	Equipment Type: 802.11b Wireless ADSL Modem
Test Engineer: Ming Jing	
Report No.: R0401155	
Test Date: 2004-02-07	
Reviewed By: Ling Zhang	
Prepared By: Bay Area Compliance Laboratory Corporation (BACL) 230 Commercial Street Sunnyvale, CA 94085 Tel: (408) 732-9162 Fax: (408) 732 9164	

Note: This test report is specially limited to the above client company and product model only. It may not be duplicated without prior written consent of Bay Area Compliance Laboratory Corporation. This report **must not** be used by the client to claim product endorsement by NVLAP or any agency of the U.S. Government.

TABLE OF CONTENTS

GENERAL INFORMATION.....	4
PRODUCT DESCRIPTION FOR EQUIPMENT UNDER TEST (EUT)	4
OBJECTIVE	4
RELATED SUBMITTAL(S)/GRANT(S).....	4
TEST METHODOLOGY	4
TEST FACILITY	4
LOCAL SUPPORT EQUIPMENT LIST AND DETAILS	5
EXTERNAL I/O CABLING LIST AND DETAILS	5
SYSTEM TEST CONFIGURATION.....	6
JUSTIFICATION	6
EUT EXERCISE SOFTWARE.....	6
SPECIAL ACCESSORIES.....	6
SCHEMATICS / BLOCK DIAGRAM	6
EQUIPMENT MODIFICATIONS	6
CONFIGURATION OF TEST SYSTEM	7
TEST SETUP BLOCK DIAGRAM.....	7
SUMMARY OF TEST RESULTS	8
§15.203 - ANTENNA REQUIREMENT.....	9
STANDARD APPLICABLE	9
§15.207(A) - CONDUCTED EMISSIONS.....	10
MEASUREMENT UNCERTAINTY	10
EUT SETUP.....	10
SPECTRUM ANALYZER SETUP	10
TEST EQUIPMENT LIST AND DETAILS.....	10
TEST PROCEDURE	10
SUMMARY OF TEST RESULTS	11
CONDUCTED EMISSIONS TEST DATA	11
PLOT OF CONDUCTED EMISSIONS TEST DATA	11
§15.209(A) - SPURIOUS EMISSION	14
STANDARD APPLICABLE	14
MEASUREMENT PROCEDURE.....	14
EQUIPMENT LISTS.....	14
MEASUREMENT RESULT	15
§15.209(F) - SPURIOUS RADIATED EMISSION.....	19
MEASUREMENT UNCERTAINTY	19
EUT SETUP.....	20
SPECTRUM ANALYZER SETUP	20
TEST EQUIPMENT LIST AND DETAILS.....	20
TEST PROCEDURE	21
CORRECTED AMPLITUDE & MARGIN CALCULATION	21
SUMMARY OF TEST RESULTS	21
RADIATED EMISSION TEST RESULT	22
§15.247(A)(2) – 6 DB BANDWIDTH	24
STANDARD APPLICABLE	24
MEASUREMENT PROCEDURE.....	24
EQUIPMENT LISTS	24
MEASUREMENT RESULT	24
§15.247(B)(3) - PEAK OUTPUT POWER MEASUREMENT.....	26
STANDARD APPLICABLE	26
MEASUREMENT PROCEDURE.....	26
EQUIPMENT LISTS	26

MEASUREMENT RESULT	26
§15.247(C) - 100 KHZ BANDWIDTH OF BAND EDGES	28
STANDARD APPLICABLE	28
MEASUREMENT PROCEDURE.....	28
EQUIPMENT LISTS	28
MEASURE RESULTS.....	28
§15.247(D) - POWER SPECTRAL DENSITY	31
STANDARD APPLICABLE	31
MEASUREMENT PROCEDURE.....	31
EQUIPMENT LISTS	31
MEASUREMENT RESULTS.....	31

GENERAL INFORMATION

Product Description for Equipment Under Test (EUT)

The *Shanghai Dare Technologies Co., Ltd's*, model: *DB108-WL*, or the "EUT" as referred to in this report is an 802.11b Wireless ADSL modem which is measured approximately 6.5"L x 5.0"W x 1.5"H.

The EUT utilized the LEI power adapter, M/N: 481207OO3CT, serial number: 0350.

** The test data gathered are from a production sample, S/N: 01011, provided by the manufacturer.*

Objective

This type approval report is prepared on behalf of *Shanghai Dare Technologies Co., Ltd* in accordance with Part 2, Subpart J, Part 15, Subparts A , B and C of the Federal Communication Commissions rules.

The objective is to determine compliance with FCC rules for Output Power, Antenna Requirements, 6 dB Bandwidth, power spectral density, 100 kHz Bandwidth of Band Edges Measurement, Out of Band Emission, Spurious Emission, Conducted and Spurious Radiated Emission.

Related Submittal(s)/Grant(s)

No Related Submittals.

Test Methodology

All measurements contained in this report were conducted with ANSI C63.4-2001, American National Standard for Methods of Measurement of Radio-Noise Emissions from Low-Voltage Electrical and Electronic Equipment in the range of 9 kHz to 40 GHz.

All radiated and conducted emissions measurement was performed at Bay Area Compliance Laboratory, Corp. The radiated testing was performed at an antenna-to-EUT distance of 3 meters.

Test Facility

The Open Area Test site used by BACL to collect radiated and conducted emission measurement data is located in the back parking lot of the building at 230 Commercial Street, Sunnyvale, California, USA.

Test site at BACL has been fully described in reports submitted to the Federal Communication Commission (FCC) and Voluntary Control Council for Interference (VCCI). The details of these reports has been found to be in compliance with the requirements of Section 2.948 of the FCC Rules on February 11 and December 10, 1997 and Article 8 of the VCCI regulations on December 25, 1997. The facility also complies with the radiated and AC line conducted test site criteria set forth in ANSI C63.4-2001.

The Federal Communications Commission and Voluntary Control Council for Interference has the reports on file and is listed under FCC file 31040/SIT 1300F2 and VCCI Registration No.: C-1298 and R-1234. The test site has been approved by the FCC and VCCI for public use and is listed in the FCC Public Access Link (PAL) database.

Additionally, BACL is a National Institute of Standards and Technology (NIST) accredited laboratory, under the National Voluntary Laboratory Accredited Program (Lab Code 200167-0). The scope of the accreditation covers the FCC Method – 47 CFR Part – Digital Devices, CISPER 22: 1997: Electromagnetic Interference – Limits and Methods of Measurement of Information Technology Equipment test methods.

Local Support Equipment List and Details

Manufacturer	Description	Model	Serial Number	FCC ID
Compaq	Tower PC	PD1000	6914CJBPA326	DOC
KDS	Monitor	KDS-7311	0891265478	EVOKD-1731
Behavior Tech	Keyboard	9113	6009300397	E5XKB9113
Logitech	Mouse	M-CAA42	LZE02062842	DOC
HP	Printer	Thinkjet 2225C	2512S43681	BS46XU2225C
Everex	Modem	Evercom 24E (EV945)	N/A	E3E5UVEV-945

Remote Support Equipment

Manufacturer	Description	Model	Serial Number	FCC ID
Arescom	DSL Simulator	CDS6020	B102903	DOC

External I/O Cabling List and Details

Cable Description	Length (M)	Port/From	To
Shielded KB Cable	1.6	KB/Host	Generic Keyboard
Shielded Cable	1.5	Mouse Port/Host	Logitech Mouse
Shielded Serial Cable	1.5	Serial /Host	EVEREX Modem
Shielded Printer Cable	1.5	Parallel/Host	HP Printer
Shielded Video Cable	1.8	VGA /Host	KDS Monitor
Phone Line	50	Line /EUT	Arescom DSL Simulator
LAN Cable	1.5	LAN Port/EUT	Compaq PC
USB Cable	1.5	USB Port/EUT	Compaq PC

SYSTEM TEST CONFIGURATION

Justification

The host system was configured for testing according to ANSI C63.4-2001.

The EUT was tested in the normal (native) operating mode to represent *worst*-case results during the final qualification test.

EUT Exercise Software

The EUT exercise program used during radiated and conducted testing was designed to exercise the system components. The test software, provided by the customer, is started the Windows terminal program under the Windows 98/2000/ME/XP operating system.

Once loaded, set the Tx channel to low, mid and high for testing.

Special Accessories

As shown in following test block diagram, all interface cables used for compliance testing are shielded. The host PC and the peripherals featured shielded metal connectors.

Schematics / Block Diagram

Please refer to Appendix A.

Equipment Modifications

No modifications were made to the EUT.

Configuration of Test System

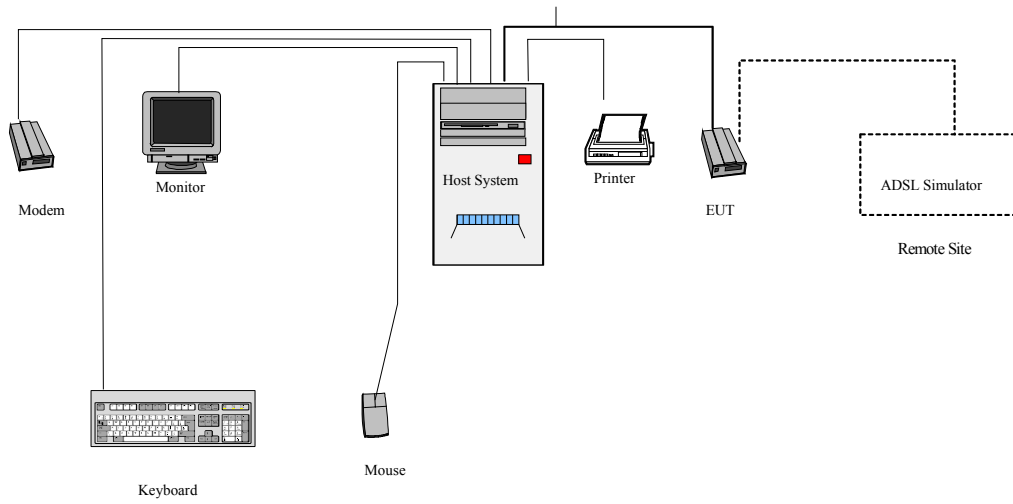

Test Setup Block Diagram

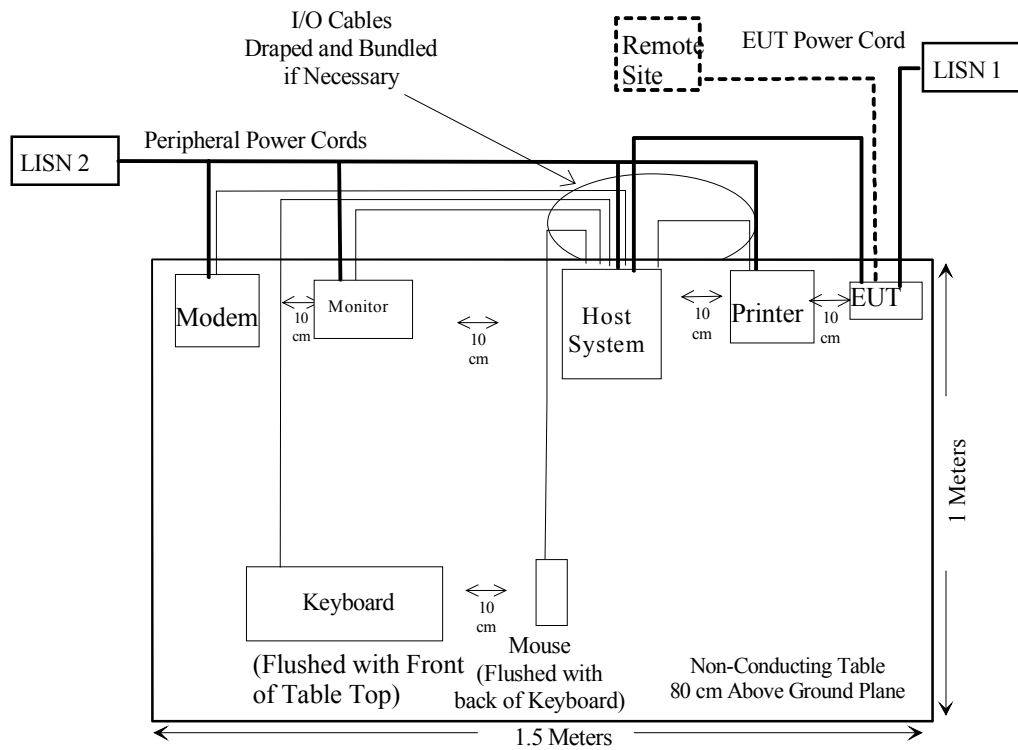

SUMMARY OF TEST RESULTS

Results reported relate only to the product tested, serial number: 00300A10540C.

FCC RULES	DESCRIPTION OF TEST	RESULT
§2.1091	RF Exposure	Pass
§15.203	Antenna Requirement	Pass
§ 15.207 (a)	Conducted Emissions	Pass
§15.209 (a)	Spurious Emission	Pass
§15.247 (a)(2)	6 dB Bandwidth	Pass
§15.247 (b)(3)	Maximum Peak Output Power	Pass
§ 15.247 (c)	100 kHz Bandwidth of Frequency Band Edge	Pass
§15.247 (d)	Peak Power Spectral Density	Pass
§15.205	Restricted Band	Pass

§15.203 - ANTENNA REQUIREMENT

Standard Applicable

According to § 15.203, an intentional radiator shall be designed to ensure that no antenna other than that furnished by the responsible party shall be used with the device.

And according to § 15.247 (b) (4), if transmitting antennas of directional gain greater than 6 dBi are used the power shall be reduced by the amount in dB that the directional gain of the antenna exceeds 6 dBi.

Refer to statement below for compliance.

“The antenna for this device is a unique antenna which has a reversed SMA connector. Please refer to the antenna specification for details”.

§15.207(a) - CONDUCTED EMISSIONS

Measurement Uncertainty

All measurements involve certain levels of uncertainties. The factors contributing to uncertainties are spectrum analyzer, cable loss, and LISN.

Based on NIS 81, The Treatment of Uncertainty in EMC Measurements, the best estimate of the uncertainty of any conducted emissions measurement at BACL is ± 2.4 dB.

EUT Setup

The measurement was performed in the shield room, using the same setup per ANSI C63.4-2001 measurement procedure. The specification used was FCC 15 Subpart B limits.

The spacing between the peripherals was 10 centimeters.

External I/O cables were draped along the edge of the test table and bundle when necessary.

Spectrum Analyzer Setup

The EMI test receiver was set to investigate the spectrum from 150 kHz to 30Mhz.

Test Equipment List and Details

Manufacturer	Description	Model	Serial Number	Cal. Date
Rohde & Schwarz	Artificial LISN	ESH2-Z5	871884/039	2003-03-28
Rohde & Schwarz	EMI Test Receiver	ESCS30	100176	2003-05-06

* **Statement of Traceability:** BACL Corp. certifies that all calibrations have been performed in accordance to NVLAP requirements, traceable to the NIST.

Test Procedure

During the conducted emission test, the power cord of the host system was connected to the auxiliary outlet of the first LISN.

Maximizing procedure was performed on the six (6) highest emissions of each modes tested to ensure EUT is compliant with all installation combination.

All data was recorded in the peak detection mode. Quasi-peak readings were only performed when an emission was found to be marginal (within -4 dB μ V of specification limits). Quasi-peak readings are distinguished with a "Qp".

Summary of Test Results

According to the recorded data in following table, the EUT complies with the FCC Conducted margin for a Class B device, with the *worst* margin reading of:

-12.8 dB at 0.150 in the Neutral mode

Environmental Conditions

Temperature:	16° C
Relative Humidity:	52%
ATM Pressure:	1032 mbar

Conducted Emissions Test Data

LINE CONDUCTED EMISSIONS				FCC PART 15 CLASS B	
Frequency MHz	Amplitude dB μ V	Detector Qp/Ave/Peak	Phase Line/Neutral	Limit dB μ V	Margin dB
0.150	53.2	QP	Neutral	66.00	-12.8
0.150	52.7	QP	Line	66.00	-13.3
7.500	29.2	Ave	Neutral	50.00	-20.8
10.000	35.6	QP	Neutral	60.00	-24.4
7.400	25.6	Ave	Line	50.00	-24.4
7.500	34.7	QP	Neutral	60.00	-25.3
2.130	28.5	QP	Line	56.00	-27.5
7.400	32.3	QP	Line	60.00	-27.7
24.800	21.5	Ave	Line	50.00	-28.5
13.600	19.9	Ave	Neutral	50.00	-30.1
0.150	23.2	Ave	Neutral	56.00	-32.8
0.150	22.2	Ave	Line	56.00	-33.8

Plot of Conducted Emissions Test Data

Plot(s) of Conducted Emissions Test Data is presented hereinafter as reference.

Bay Area Compliance Laboratory Corp
Class B

27. Jan 04 14: 43

Way
2004-1-27

EUT: DB108-WL
 Manuf: Shanghai Dare
 Op Cond: Normal
 Operator: HANG
 Comment: N
 120V adapter

Scan Settings (3 Ranges)

Frequencies			Receiver Settings					
Start	Stop	Step	IF BW	Detector	M-Time	Atten	Preamp	
150k	1M	5k	9k	QP+AV	20ms	15dB LN	OFF	
1M	5M	10k	9k	QP+AV	1ms	15dB LN	OFF	
5M	30M	100k	9k	QP+AV	1ms	15dB LN	OFF	

Final Measurement: x QP / + AV
 Meas Time: 1 s
 Subranges: 25
 Acc Margin: 8dB

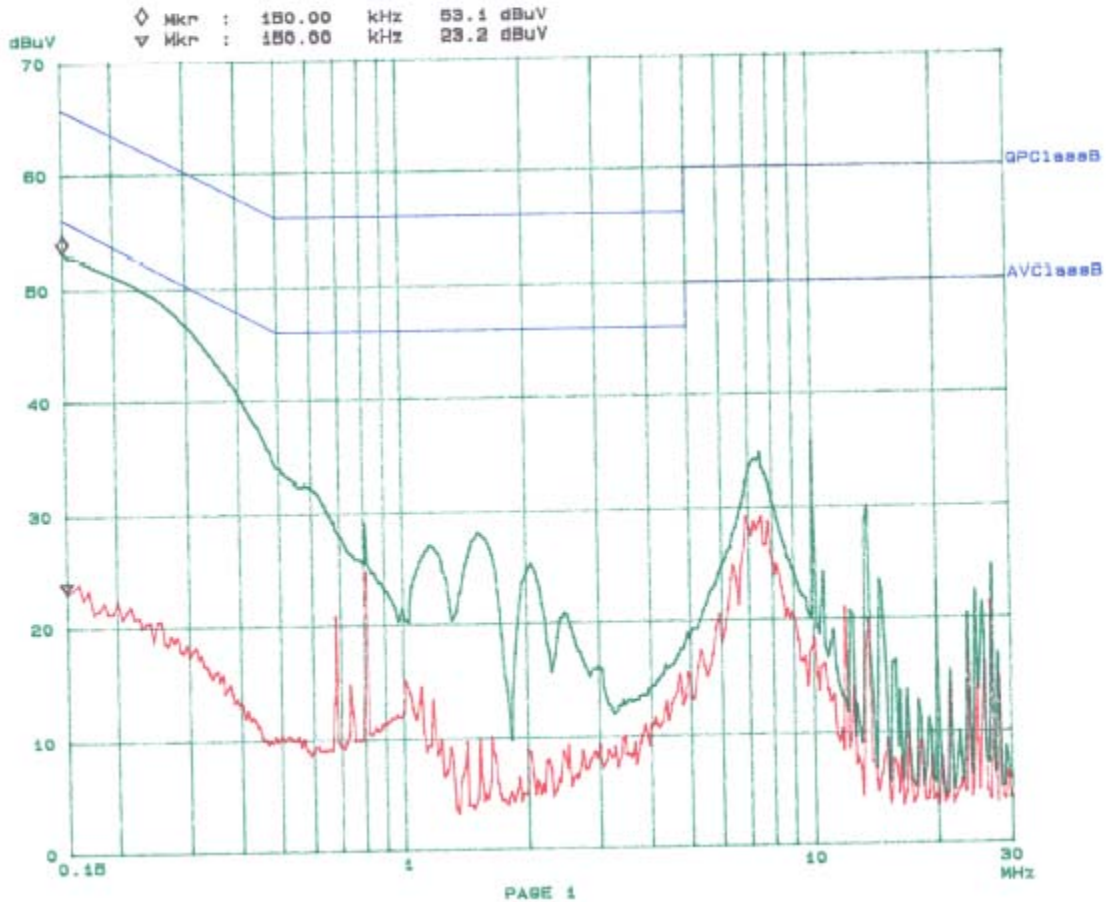

Bay Area Compliance Laboratory Corp
Class B

27. Jan 04 14:23

Hay
2004-1-27

EUT: DB108-WL
 Manuf: Shanghai Dare
 Op Cond: Normal
 Operator: Hang
 Comment: L
 120V adapter

Scan Settings (3 Ranges)			Receiver Settings				
Start	Stop	Step	IF BW	Detector	M-Time	Atten	Preamp
150k	1M	5k	9k	QP+AV	20ms	15dB	OFF
1M	5M	10k	9k	QP+AV	1ms	15dB	OFF
5M	30M	100k	9k	QP+AV	1ms	15dB	OFF

Final Measurement: x QP / + AV
 Meas Time: 1 s
 Subranges: 25
 Acc Margin: 6dB

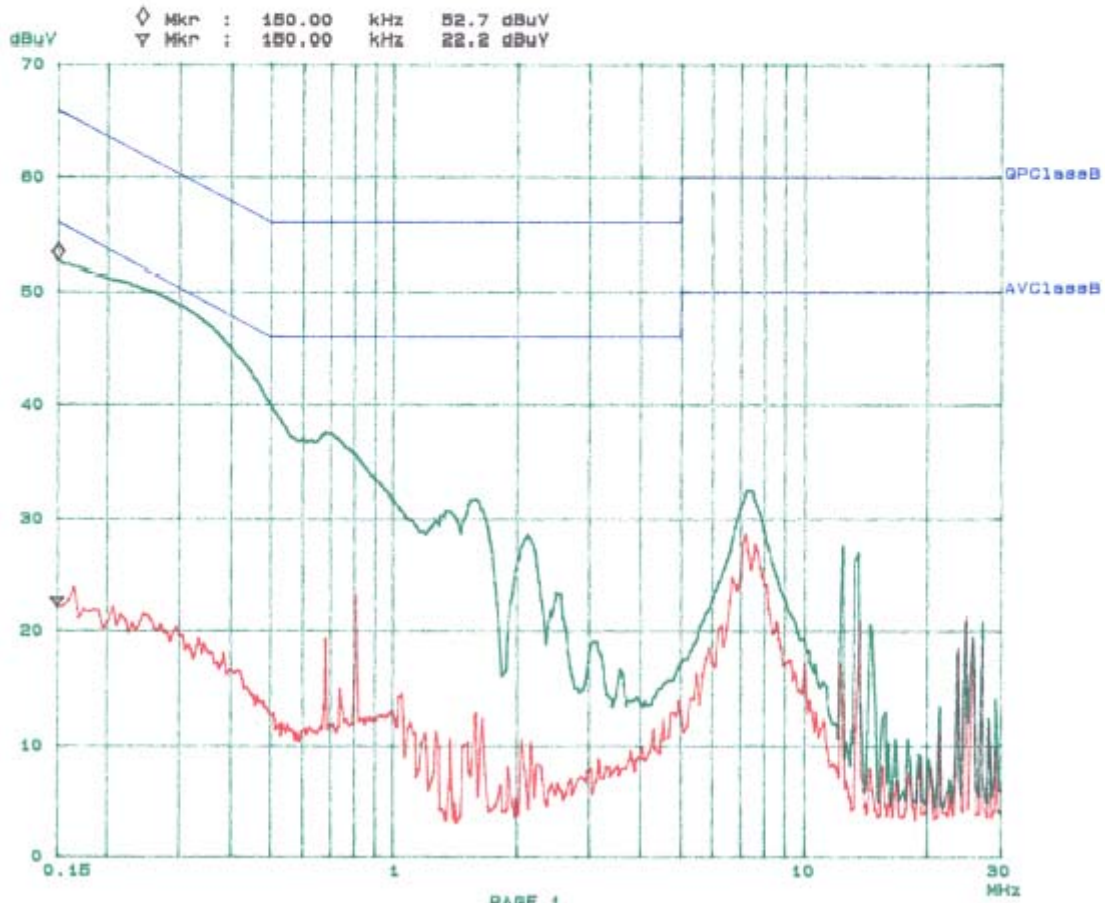

§15.209(a) - SPURIOUS EMISSION

Standard Applicable

According to §15.209 (a), except as provided elsewhere in the subpart of 15.209, the emissions from an intentional radiator shall not exceed the field strength levels specified in the following table:

Frequency (MHz)	Measurement Field strength (microvolts/meter)	distance (meters)
0.009-0.490.....	2400/F(kHz)	300
0.490-1.705.....	24000/F(kHz)	30
1.705-30.0.....	30	30
30-88.....	100 **	3
88-216.....	150 **	3
216-960.....	200 **	3
Above 960.....	500	3

** Except as provided in paragraph (g), fundamental emissions from intentional radiators operating under this section shall not be located in the frequency bands 54-72 MHz, 76-88 MHz, 174-216 MHz or 470-806 MHz. However, operation within these frequency bands is permitted under other sections of this part, e.g., §§ 15.231 and 15.241

Measurement Procedure

1. Check the calibration of the measuring instrument (SA) using either an internal calibrator or a known signal from an external generator.
2. Position the EUT on a bench without connection to measurement instrument. Turn on the EUT and connect its antenna terminal to measurement instrument via a low loss cable. Then set it to any one measured frequency within its operating range, and make sure the instrument is operated in its linear range.
3. Set the SA on Max-Hold Mode, and then keep the EUT in transmitting mode. Record all the signals from each channel until each one has been recorded.
4. Set the SA on View mode and then plot the result on SA screen.
5. Repeat above procedures until all frequencies measured were complete.

Equipment Lists

Manufacturer	Model No.	Description	Calibration Date
HP	8565EC	Spectrum Analyzer	2003-06-30

Measurement Result

Please refer to following pages for plots of spurious emission.

Environmental Conditions

Temperature:	16° C
Relative Humidity:	52%
ATM Pressure:	1032 mbar

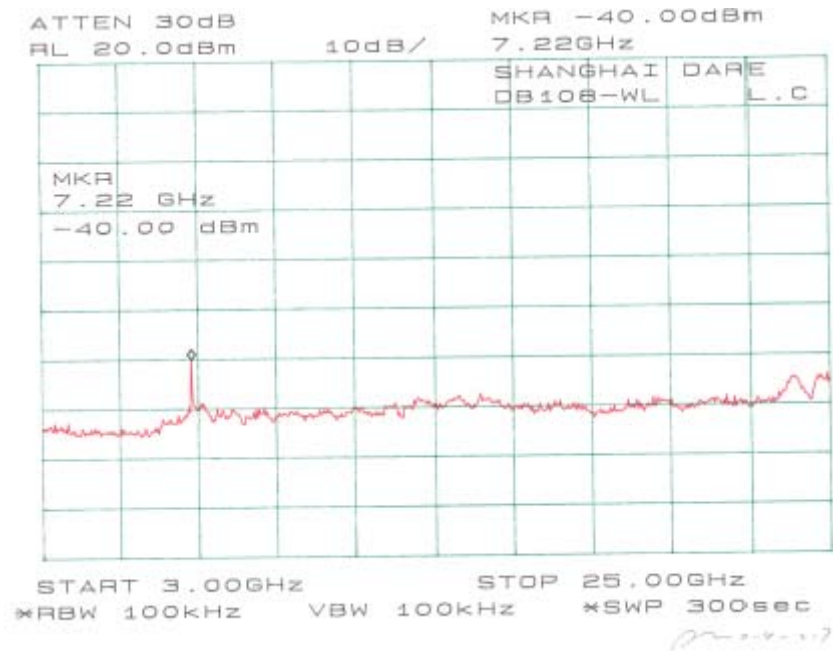
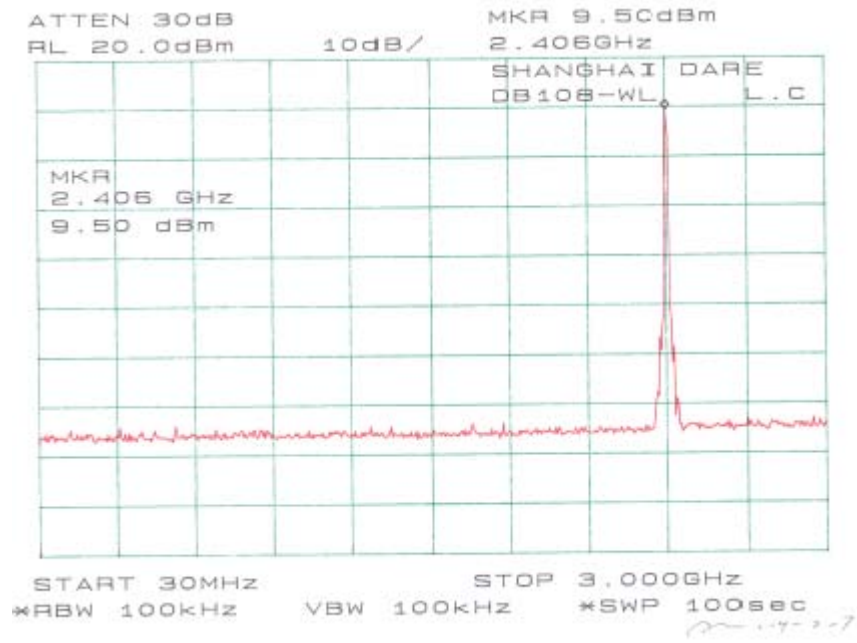

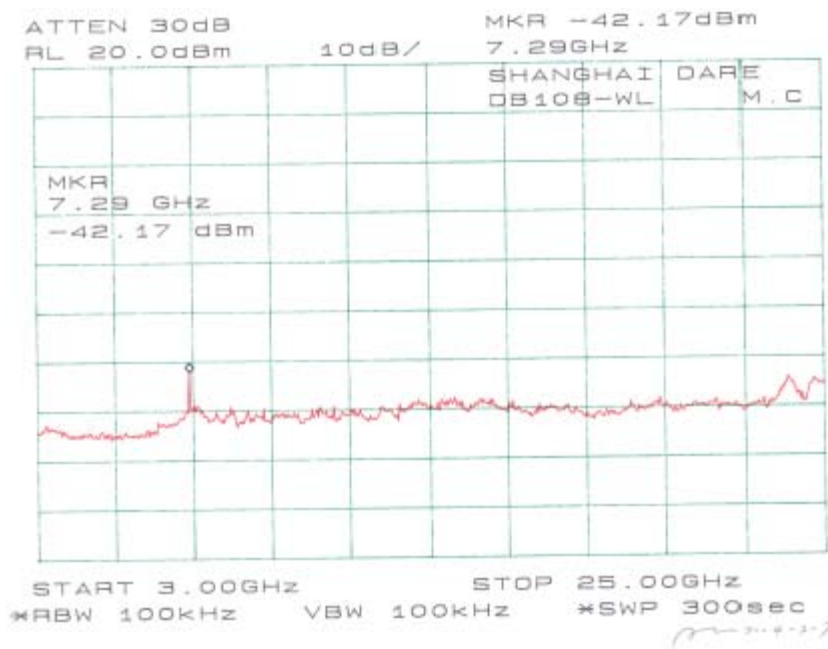
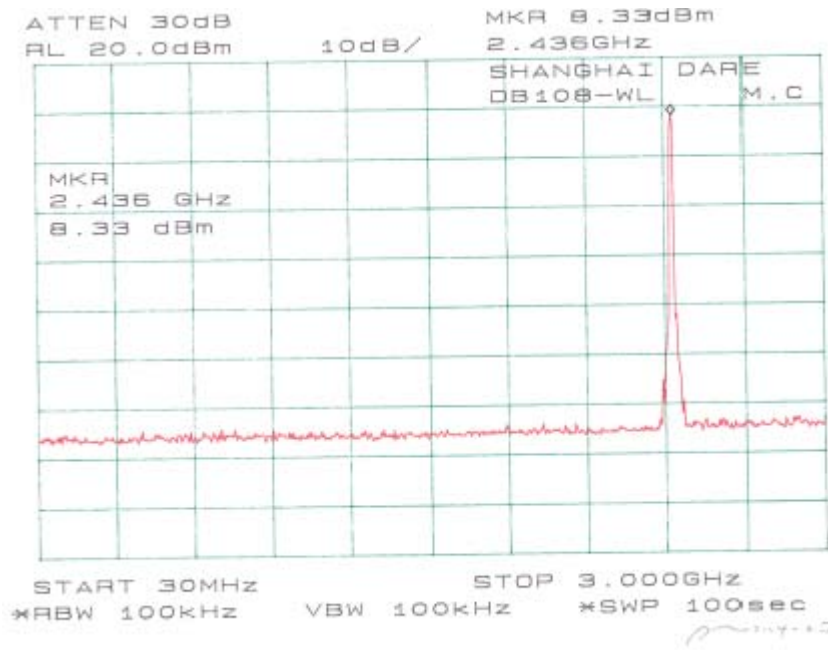

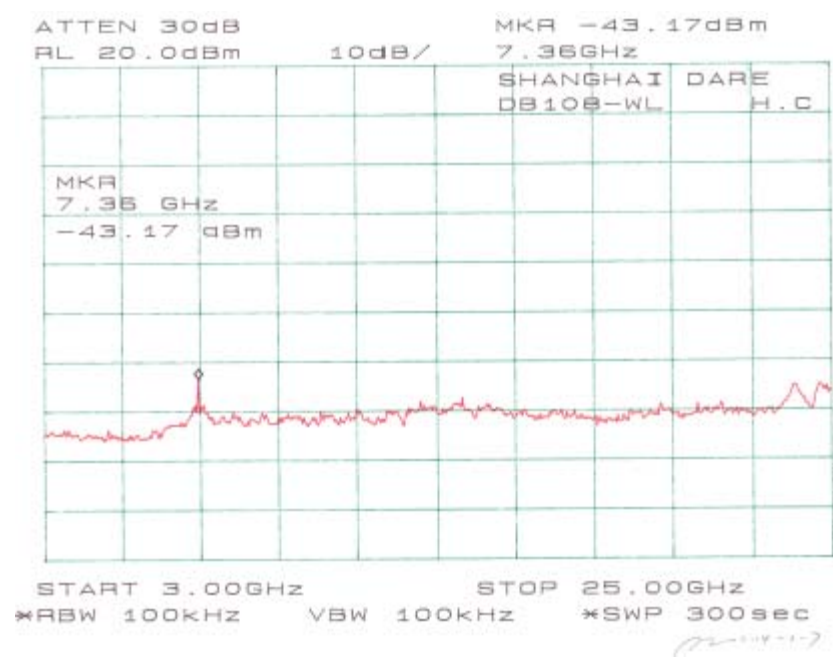
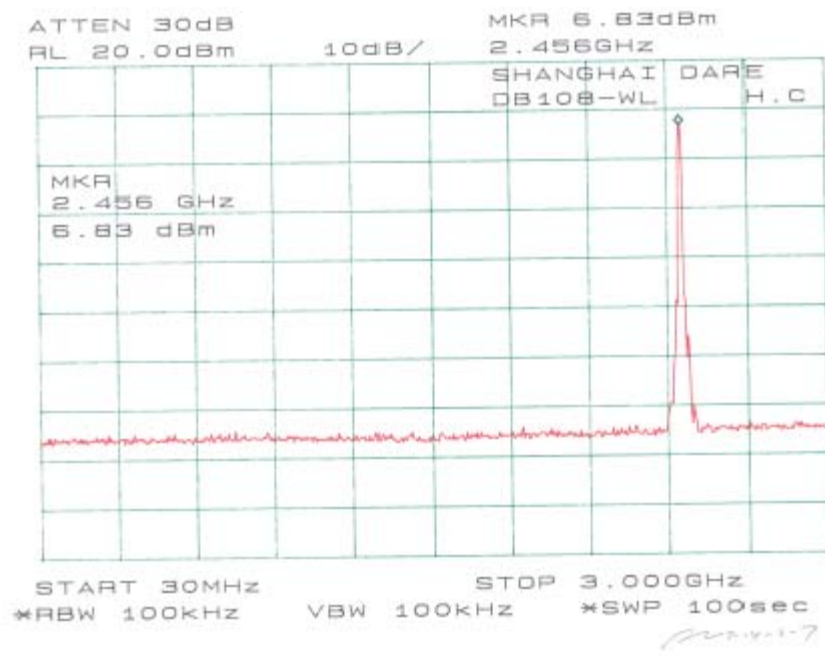

§15.209(f) - SPURIOUS RADIATED EMISSION

Measurement Uncertainty

All measurements involve certain levels of uncertainties. The factors contributing to uncertainties are spectrum analyzer, cable loss, antenna factor calibration, antenna directivity, antenna factor variation with height, antenna phase center variation, antenna factor frequency interpolation, measurement distance variation, site imperfections, mismatch (average), and system repeatability.

Based on NIS 81, The Treatment of Uncertainty in EMC Measurements, the best estimate of the uncertainty of a radiation emissions measurement at BACL is ± 4.0 dB.

According to §15.205, except as shown in paragraph (d) of this section, only spurious emissions are permitted in any of the frequency bands listed below:

MHz	MHz	MHz	GHz
0.090 – 0.110	16.42 – 16.423	399.9 – 410	4.5 – 5.15
¹ 0.495 – 0.505	16.69475 – 16.69525	608 – 614	5.35 – 5.46
2.1735 – 2.1905	16.80425 – 16.80475	960 – 1240	7.25 – 7.75
4.125 – 4.128	25.5 – 25.67	1300 – 1427	8.025 – 8.5
4.17725 – 4.17775	37.5 – 38.25	1435 – 1626.5	9.0 – 9.2
4.20725 – 4.20775	73 – 74.6	1645.5 – 1646.5	9.3 – 9.5
6.215 – 6.218	74.8 – 75.2	1660 – 1710	10.6 – 12.7
6.26775 – 6.26825	108 – 121.94	1718.8 – 1722.2	13.25 – 13.4
6.31175 – 6.31225	123 – 138	2200 – 2300	14.47 – 14.5
8.291 – 8.294	149.9 – 150.05	2310 – 2390	15.35 – 16.2
8.362 – 8.366	156.52475 – 156.52525	2483.5 – 2500	17.7 – 21.4
8.37625 – 8.38675	156.7 – 156.9	2655 – 2900	22.01 – 23.12
8.41425 – 8.41475	162.0125 – 167.17	3260 – 3267	23.6 – 24.0
12.29 – 12.293	167.72 – 173.2	3332 – 3339	31.2 – 31.8
12.51975 – 12.57725	240 – 285	3345.8 – 3358	36.43 – 36.5
13.36 – 13.41	322 – 335.4	3600 – 4400	(²)

¹ Until February 1, 1999, this restricted band shall be 0.490-0.510MHz

² Above 38.6

Except as provided in paragraph (d) and (e), the filed strength of emissions appearing within these frequency bands shall not exceed the limits shown in Section 15.209. At frequencies equal to or less than 1000MHz, compliance with the limits in Section 15.209 shall be demonstrated using measurement instrumentation employing a CISPR quasi-peak detector. Above 1000MHz, compliance with the emission limits in Section 15.209 shall be demonstrated based on the average value of the measured emissions. The provisions in Section 15.35 apply to these measurements.

According to §15.209, the device shall meet radiated emission general requirements.

Except for Class A device, the filed strength of radiated emissions from unintentional radiators at a distance of 3 meters shall not exceed the following values:

Frequency of Emission (MHz)	Field Strength (Microvolts/meter)	dB (dB μ V/meter)
30 - 88	100	40
88 - 216	150	43.5
216 - 960	200	46
Above 960	500	54

EUT Setup

The radiated emission tests were performed in the open area 3-meter test site, using the setup accordance with the ANSI C63.4-2001. The specification used was the FCC 15.209 limits.

The spacing between the peripherals was 10 centimeters.

External I/O cables were draped along the edge of the test table and bundle when necessary.

Spectrum Analyzer Setup

According to FCC Rules, 47 CFR, Section 15.33, the frequency was investigated from 30 to 2500 MHz.

During the radiated emission test, the spectrum analyzer was set with the following configurations:

<i>Frequency Range</i>	<i>RBW</i>	<i>Video B/W</i>
Below 30MHz	10kHz	10kHz
30 – 1000MHz	100kHz	100kHz
Above 1000MHz	1MHz	1MHz

Test Equipment List and Details

Manufacturer	Description	Model	Serial Number	Cal. Date
HP	Spectrum Analyzer	8568B	2601A02165	2003-07-03
HP	Amplifier	8447E	2944A10187	2003-09-23
HP	Quasi-Peak Adapter	85650A	3019A05393	2003-06-13
EMCO	Biconical Antenna	3110B	9309-1165	2003-10-11
EMCO	Log Periodic Antenna	3146	2101	2003-10-11
A.H. System	Horn Antenna	SAS-200-571	261	2003-08-02

* **Statement of Traceability:** BACL Corp. certifies that all calibrations have been performed in accordance to NVLAP requirements, traceable to the NIST.

Test Procedure

For the radiated emissions test, the EUT, and all support equipment power cords was connected to the AC floor outlet.

Maximizing procedure was performed on the highest emissions to ensure that the EUT complied with all installation combinations.

All data was recorded in the peak detection mode. Quasi-peak readings performed only when an emission was found to be marginal (within -4 dB μ V of specification limits), and are distinguished with a "Qp" in the data table.

Corrected Amplitude & Margin Calculation

The Corrected Amplitude is calculated by adding the Antenna Factor and Cable Factor, and subtracting the Amplifier Gain from the Amplitude reading. The basic equation is as follows:

$$\text{Corr. Ampl.} = \text{Indicated Reading} + \text{Antenna Factor} + \text{Cable Factor} - \text{Amplifier Gain}$$

The "**Margin**" column of the following data tables indicates the degree of compliance with the applicable limit. For example, a margin of -7dB μ V means the emission is 7dB μ V below the maximum limit for Class B. The equation for margin calculation is as follows:

$$\text{Margin} = \text{Corr. Ampl.} - \text{FCC 15.209 Limit}$$

Summary of Test Results

According to the data in section 12.7, the EUT complied with the FCC Title 47, Part 15, Subpart C, section 15.205, 15.207 and 15.247, and had the worst margin of:

Environmental Conditions

Temperature:	16° C
Relative Humidity:	52%
ATM Pressure:	1032 mbar

-4.5 dB at 2390.00 MHz in the **Vertical** polarization, Low Channel

-17.0 dB at 4874.00 MHz in the **Vertical** polarization, Middle Channel

-5.8 dB at 2483.00 MHz in the **Vertical** polarization, High Channel

-6.4 dB at 989.33 MHz in the **Horizontal** polarization, Unwanted Emission

Radiated Emission Test Result

INDICATED			TABLE	ANTENNA		CORRECTION FACTOR			CORRECTED AMPLITUDE	FCC 15 SUBPART C	
Frequency	Ampl.	Comments	Angle	Height	Polar	Antenna	Cable	Amp.	Corr. Ampl.	Limit	Margin
MHz	dB μ V/m		Degree	Meter	H/V	dB μ V/m	DB	DB	dB μ V/m	dB μ V/m	dB
Low Channel, 1-25GHz											
2412.00	112.3	Fund/Peak	270	1.5	v	28.1	3.4	35.2	108.6		
2412.00	104.5	Fund/Peak	0	1.2	h	28.1	3.4	35.2	100.8		
2412.00	106.7	Fund/Ave	270	1.5	v	28.1	3.4	35.2	103.0		
2412.00	98.2	Fund/Ave	0	1.2	h	28.1	3.4	35.2	94.5		
2390.00	53.2	Ave	270	1.5	v	28.1	3.4	35.1	49.6	54	-4.5
2390.00	45.9	Ave	180	1.5	h	28.1	3.4	35.1	42.3	54	-11.8
2390.00	61.2	Peak	270	1.5	v	28.1	3.4	35.1	57.6	74	-16.5
4824.00	32.8	Ave	90	1.2	v	32.5	4.9	33.0	37.2	54	-16.8
4824.00	31.9	Ave	110	1.5	h	32.5	4.9	33.0	36.3	54	-17.7
2390.00	53.7	Peak	180	1.5	h	28.1	3.4	35.1	50.1	74	-24.0
4824.00	44.1	Peak	90	1.2	v	32.5	4.9	33.0	48.5	74	-25.5
4824.00	43.5	Peak	110	1.5	h	32.5	4.9	33.0	47.9	74	-26.1
Middle Channel, 1-25GHz											
2437.00	112.1	Fund/Peak	230	1.2	v	28.1	3.4	35.2	108.4		
2437.00	104.8	Fund/Peak	90	1.5	h	28.1	3.4	35.2	101.1		
2437.00	106.3	Fund/Ave	230	1.2	v	28.1	3.4	35.2	102.6		
2437.00	98.5	Fund/Ave	90	1.5	h	28.1	3.4	35.2	94.8		
4874.00	32.6	Ave	90	1.5	v	32.5	4.9	33.0	37.0	54	-17.0
4874.00	31.7	Ave	15	1.2	h	32.5	4.9	33.0	36.1	54	-17.9
4874.00	43.8	Peak	90	1.5	v	32.5	4.9	33.0	48.2	74	-25.8
4874.00	43.3	Peak	15	1.2	h	32.5	4.9	33.0	47.7	74	-26.3
High Channel, 1-25GHz											
2462.00	112.2	Fund/Peak	110	1.8	v	28.1	3.4	35.2	108.5		
2462.00	105.1	Fund/Peak	0	1.5	h	28.1	3.4	35.2	101.4		
2462.00	106.1	Fund/Ave	110	1.8	v	28.1	3.4	35.2	102.4		
2462.00	99.2	Fund/Ave	0	1.5	h	28.1	3.4	35.2	95.5		
2483.50	52.9	Ave	90	1.6	v	28.1	3.4	36.1	48.3	54	-5.8
2483.50	45.1	Ave	15	1.8	h	28.1	3.4	36.1	40.5	54	-13.6
4924.00	32.7	Ave	60	1.2	v	32.5	4.9	33.0	37.1	54	-16.9
2483.50	60.8	Peak	90	1.6	v	28.1	3.4	36.1	56.2	74	-17.9
4924.00	31.6	Ave	30	1.5	h	32.5	4.9	33.0	36.0	54	-18.0
2483.50	53.4	Peak	15	1.8	h	28.1	3.4	36.1	48.8	74	-25.3
4924.00	43.9	Peak	60	1.2	v	32.5	4.9	33.0	48.3	74	-25.7
4924.00	43.4	Peak	30	1.5	h	32.5	4.9	33.0	47.8	74	-26.2

Frequency MHz	Indicated		Table Height Meter	Antenna		Correction Factor			FCC 15 Subpart B	
	Ampl. dB μ V/m	Direction Degree		Polar H/V	Antenna dB μ V/m	Cable Loss dB μ V/m	Amp. dB	Corr. Ampl. dB μ V/m	Limit dB μ V/m	Margin dB
989.33	40.3	310	1.8	v	23.8	4.2	28.7	39.6	46	-6.4
45.52	44.1	15	1.2	h	11.1	1.1	28.5	27.8	40	-12.3
30.97	39.8	180	1.5	h	14.9	0.8	28.7	26.8	40	-13.2
304.51	39.5	130	1.6	h	14.4	2.3	28.2	28.0	46	-18.0
348.16	38.4	270	1.2	v	15.4	2.3	28.2	27.9	46	-18.1
237.58	41.2	90	1.5	v	12.6	2.2	28.5	27.5	46	-18.5

FUND = Fundamental

AVG = average

§15.247(a)(2) – 6 DB BANDWIDTH

Standard Applicable

According to §15.247(a)(2), for digital modulation techniques, the minimum 6dB bandwidth shall be at least 500 kHz.

Measurement Procedure

1. Check the calibration of the measuring instrument using either an internal calibrator or a known signal from an external generator.
2. Position the EUT without connection to measurement instrument. Turn on the EUT and connect it to measurement instrument. Then set it to any one convenient frequency within its operating range. Set a reference level on the measuring instrument equal to the highest peak value.
3. Measure the frequency difference of two frequencies that were attenuated 6 dB from the reference level. Record the frequency difference as the emission bandwidth. (6 dB bandwidth for DTS)
4. Repeat above procedures until all frequencies measured were complete.

Equipment Lists

Manufacturer	Model No.	Description	Calibration Date
HP	8565EC	Spectrum Analyzer	2003-06-30

Measurement Result

Environmental Conditions

Temperature:	16° C
Relative Humidity:	52%
ATM Pressure:	1032 mbar

Test Result

Channel	Frequency (MHz)	Measured (MHz)	Measured (kHz)	Standard (kHz)	Result
Low	2412	11.75	11750	≥ 500	Pass
Mid	2437	11.50	11500	≥ 500	Pass
High	2462	11.67	11670	≥ 500	Pass

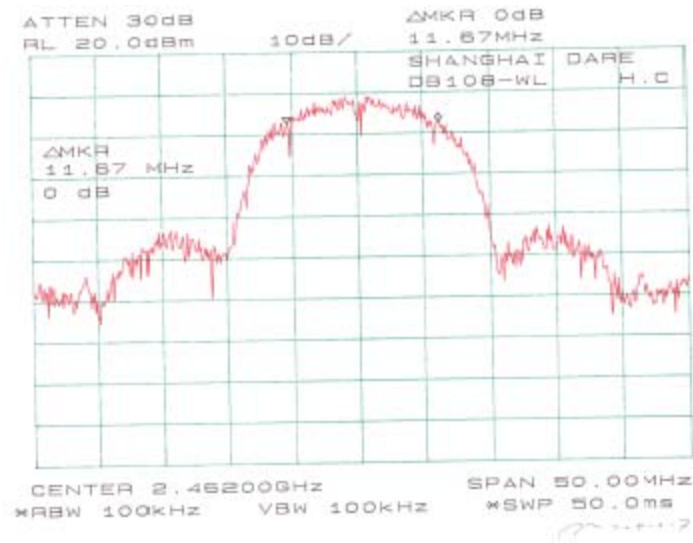
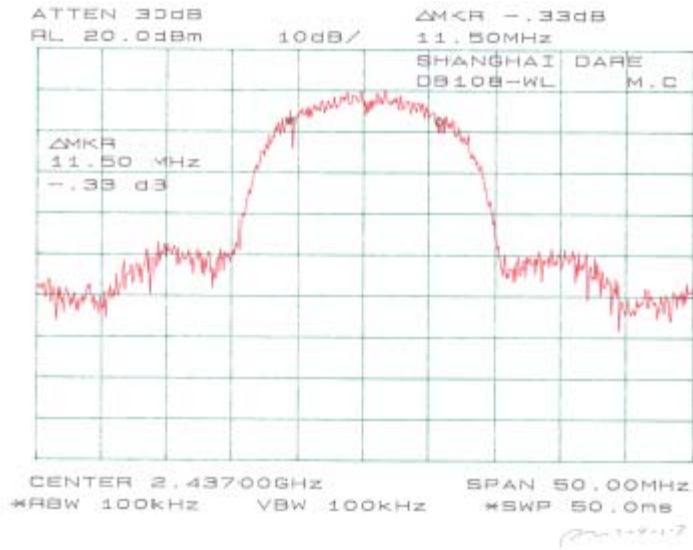
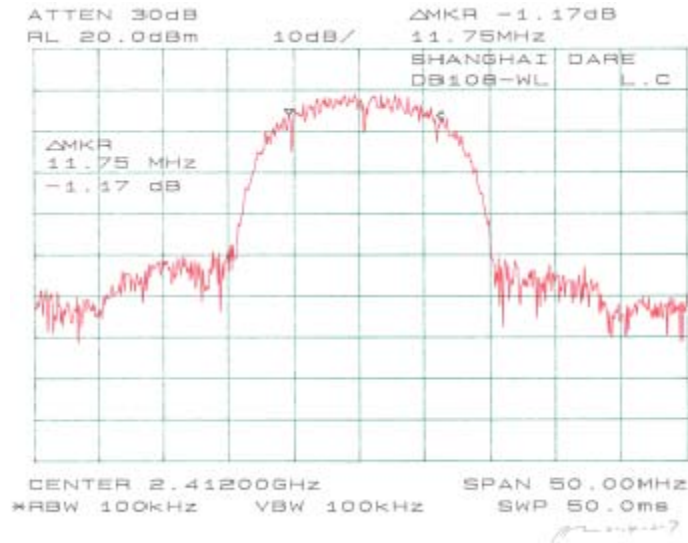

§15.247(b)(3) - PEAK OUTPUT POWER MEASUREMENT

Standard Applicable

According to §15.247(b) (3), for systems using digital modulation in 2400-2483.5 MHz: 1 Watt

Measurement Procedure

1. Place the EUT on a bench and set it in transmitting mode.
2. Remove the antenna from the EUT and then connect a low loss RF cable from the antenna port to a spectrum analyzer.
3. Add a correction factor to the display.

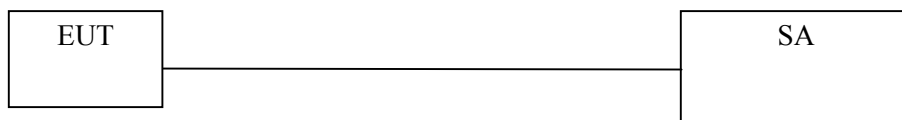

Equipment Lists

Manufacturer	Model No.	Description	Calibration Date
HP	8565EC	Spectrum Analyzer	2003-06-30

Measurement Result

Environmental Conditions

Temperature:	16° C
Relative Humidity:	52%
ATM Pressure:	1032 mbar

Channel	Frequency (MHz)	RF Power (dBm)	Correction Factor (dB)	Corrected RF Power (dBm)	Corrected RF Power (W)	Limit
Low (Ch1)	2412	9.33	7.6	16.93	0.04932	1W (30dBm)
Mid (Ch7)	2437	9.50	7.6	17.10	0.05129	1W (30dBm)
High (Ch11)	2462	9.50	7.6	17.10	0.05129	1W (30dBm)

Note: Correction Factor = $10\log(BW_{6dB}/RBW) = 10\log(11.6/2) = 7.6$ dB

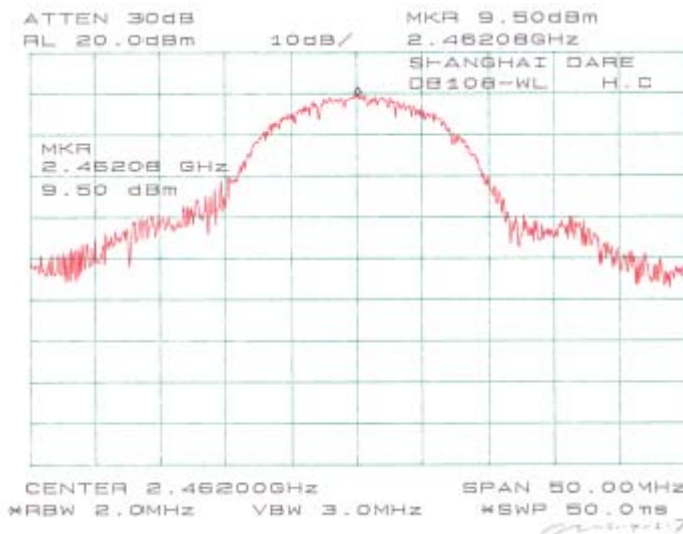
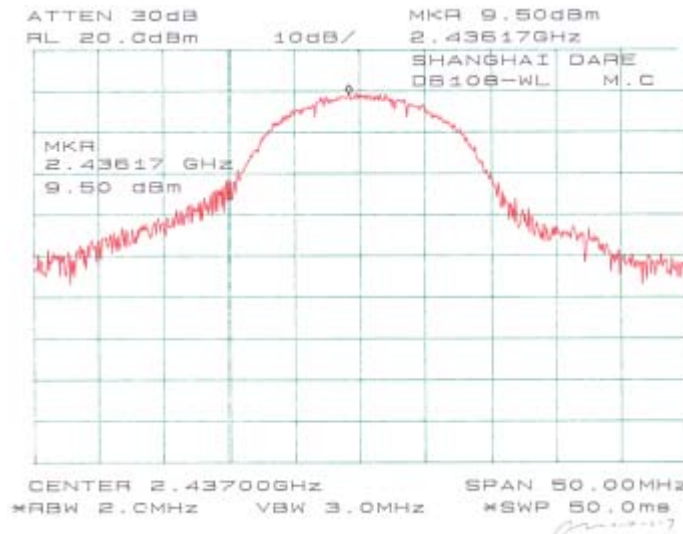
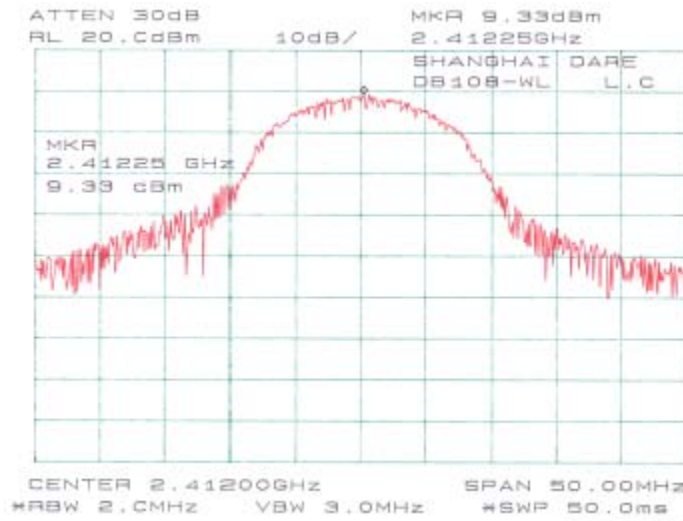

§15.247(c) - 100 KHZ BANDWIDTH OF BAND EDGES

Standard Applicable

According to §15.247(c), in *any* 100 kHz bandwidth outside the frequency bands in which the spread spectrum intentional radiator is operating, the radio frequency power that is produced by the intentional radiator shall be at least 20 dB below that in the 100 kHz bandwidth within the band that contains the highest level of the desired power, based on either an RF conducted or a radiated measurement. In addition, radiated emissions which fall in the restricted bands, as defined in §15.205(a), must also comply with the radiated emission limits specified in §15.209(a) see §15.205(c).

Measurement Procedure

1. Check the calibration of the measuring instrument using either an internal calibrator or a known signal from an external generator.
2. Position the EUT without connection to measurement instrument. Turn on the EUT and connect its antenna terminal to measurement instrument via a low loss cable. Then set it to any one measured frequency within its operating range, and make sure the instrument is operated in its linear range.
3. Set both RBW and VBW of spectrum analyzer to 100 kHz with a convenient frequency span including 100kHz bandwidth from band edge.
4. Measure the highest amplitude appearing on spectral display and set it as a reference level. Plot the graph with marking the highest point and edge frequency.
5. Repeat above procedures until all measured frequencies were complete.

Equipment Lists

Manufacturer	Model No.	Description	Calibration Date
HP	8565EC	Spectrum Analyzer	2003-06-30

Measure Results

Environmental Conditions

Temperature:	16° C
Relative Humidity:	52%
ATM Pressure:	1032 mbar

Please refer to following pages for plots of band edge.

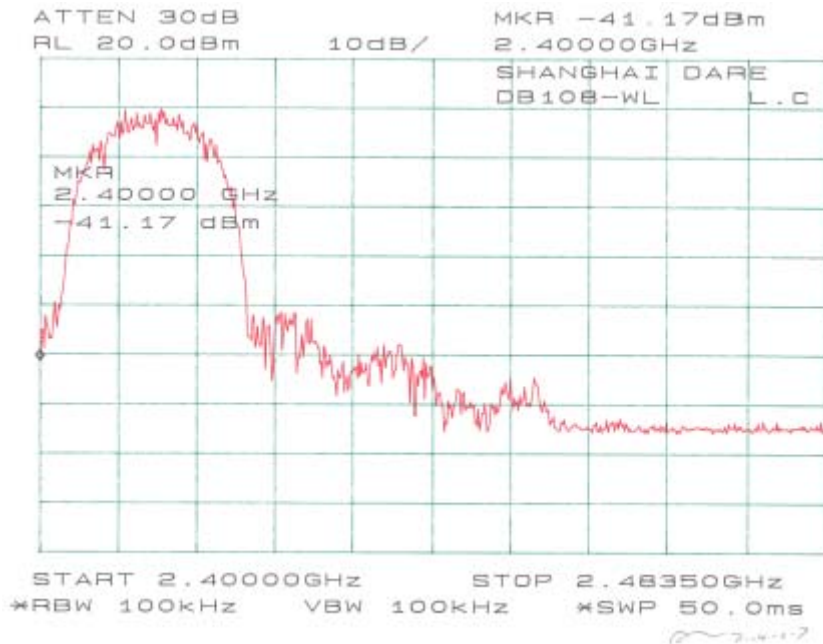
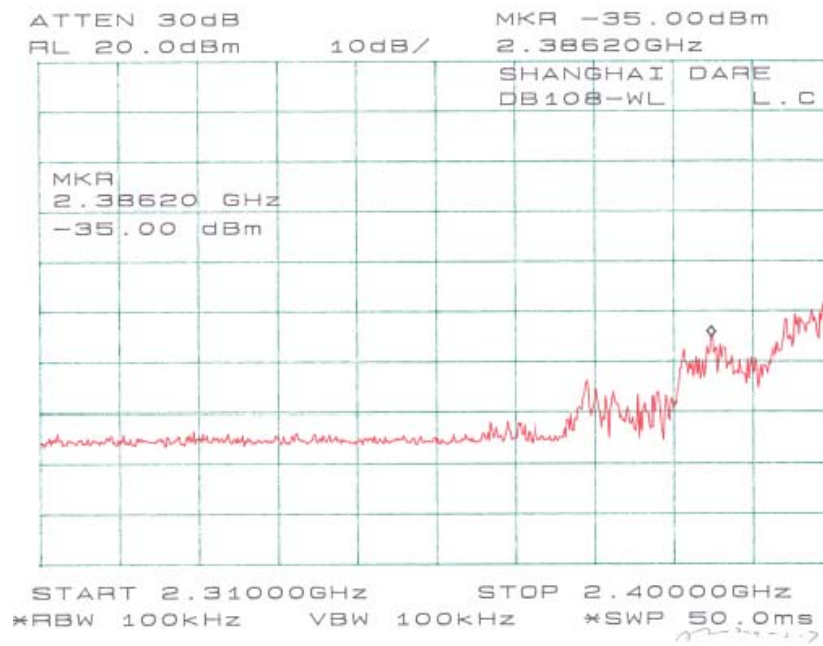

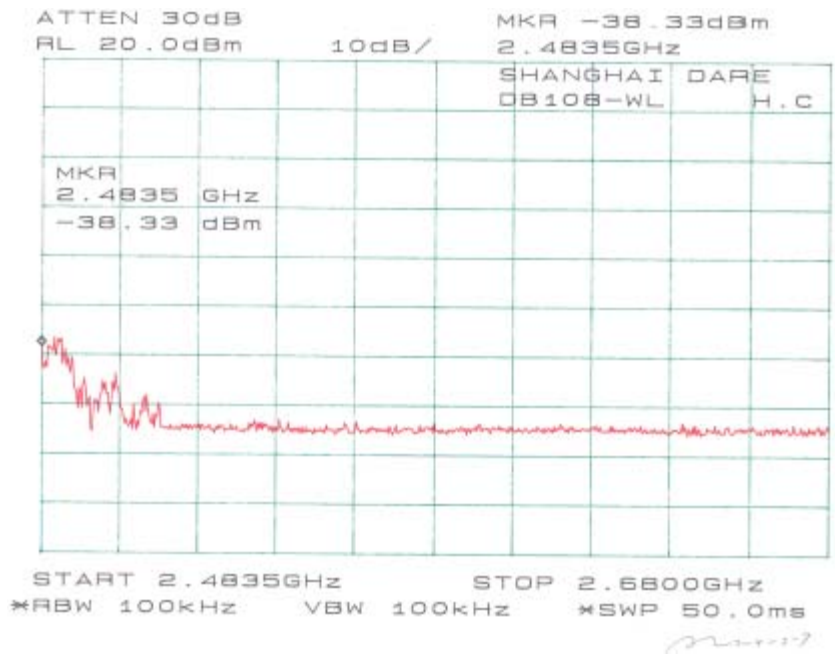
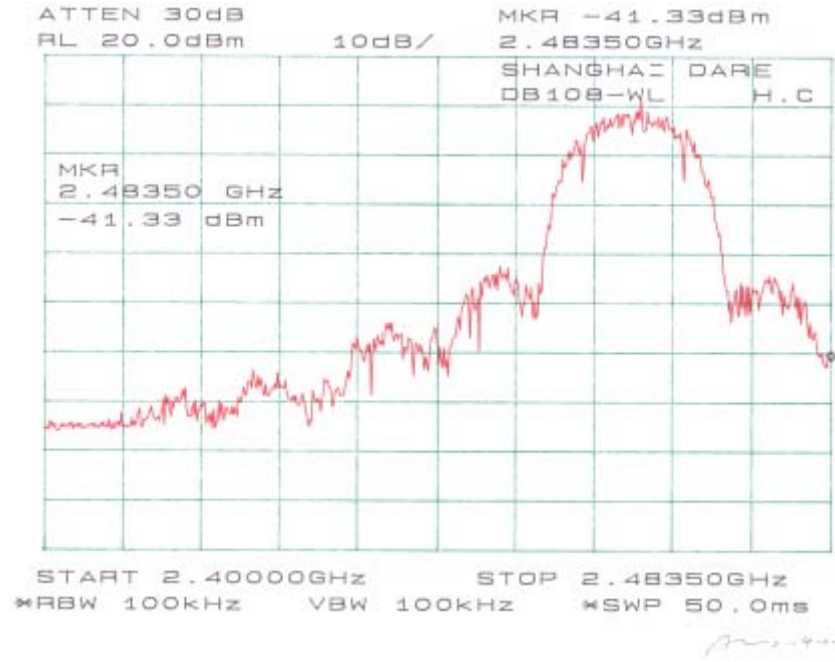

§15.247(d) - POWER SPECTRAL DENSITY

Standard Applicable

According to §15.247 (d), for direct sequence systems, the peak power spectral density conducted from the intentional radiator to the antenna shall not be greater than 8 dBm in any 3 kHz band during any time interval of continuous transmission.

Measurement Procedure

1. Check the calibration of the measuring instrument using either an internal calibrator or a known signal from an external generator.
2. Position the EUT was set without connection to measurement instrument. Turn on the EUT and connect its antenna terminal to measurement instrument via a low loss cable. Then set it to any one measured frequency within its operating range, and make sure the instrument is operated in its linear range.
3. Adjust the center frequency of SA on any frequency be measured and set SA to 6MHz span mode. And then, set RBW and VBW of spectrum analyzer to proper value. (DTS)
4. Adjust the center frequency of SA on any frequency be measured and set SA to 50MHz span mode. And then, set RBW and VBW of spectrum analyzer to proper value. (UNII)
5. Repeat above procedures until all frequencies measured were complete.

Equipment Lists

Manufacturer	Model No.	Description	Calibration Date
HP	8565EC	Spectrum Analyzer	2003-06-30

Measurement Results

Environmental Conditions

Temperature:	16° C
Relative Humidity:	52%
ATM Pressure:	1032 mbar

Channel	Frequency (MHz)	Peak Power Spectral Density (dBm)	Standard (dBm)	Result
Low	2412	-8.50	≤ 8	Pass
Mid	2437	-8.00	≤ 8	Pass
High	2462	-9.00	≤ 8	Pass

