

MEASUREMENT REPORT
FCC Part 15.239 / ISED RSS-210 FM Transmitter

Applicant Name:
Sirius XM Satellite Radio
1500 Eckington Place, NE
Washington, DC 20002
United States

Date of Testing:
3/20/2023 - 3/30/2023
Test Site/Location:
Element Lab. Columbia, MD, USA
Test Report Serial No.:
1M2303100028-03.RS2

FCC ID:	RS2SXZR2
IC:	5750A-SXZR2C
APPLICANT:	Sirius XM Satellite Radio

Application Type: Certification
Model/HVIN: SXZR2
EUT Type: Satellite Radio with FM transmitter
Max. RF Output Power: -36.964dBm (0.201uW)
Frequency Range: 88 – 108MHz
FCC & ISED Classification: Low Power Communication Device Transmitter (DXX)
FCC Rule Part(s): FCC Part 15.239
ISED Specification(s): RSS-210 Issue 10
Test Procedure(s): ANSI C63.10-2013

This equipment has been shown to be capable of compliance with the applicable technical standards as indicated in the measurement report and has been tested in accordance with the measurement procedures specified in ANSI C63.4-2014 (See Test Report). The results shown herein are also deemed satisfactory evidence of compliance with Industry Canada Interference-Causing Equipment Standard ICES-003. These measurements were performed with no deviation from the standards. Test results reported herein relate only to the item(s) tested.

I attest to the accuracy of data. All measurements reported herein were performed by me or were made under my supervision and are correct to the best of my knowledge and belief. I assume full responsibility for the completeness of these measurements and vouch for the qualifications of all persons taking them.



RJ Ortanez
Executive Vice President

FCC ID: RS2SXZR2		MEASUREMENT REPORT (CERTIFICATION)	Approved by: Technical Manager
Test Report S/N: 1M2303100028-03.RS2	Test Dates: 3/20/2023 - 3/30/2023	EUT Type: Satellite Radio with FM transmitter	Page 1 of 43

TABLE OF CONTENTS

1.0	INTRODUCTION.....	3
1.1	Scope.....	3
1.2	Element Test Location	3
1.3	Test Facility / Accreditations	3
2.0	PRODUCT INFORMATION	4
2.1	Equipment Description.....	4
2.2	Device Capabilities	4
2.3	Test Configuration	4
2.4	Software and Firmware.....	4
2.5	EMI Suppression Device(s)/Modifications.....	4
3.0	DESCRIPTION OF TESTS	5
3.1	Evaluation Procedure	5
3.2	Radiated Emissions	5
3.3	Environmental Conditions	5
4.0	ANTENNA REQUIREMENTS.....	6
5.0	SAMPLE CALCULATIONS.....	7
5.1	Conducted Emission Measurement Sample Calculation	7
5.2	Radiated Emission Measurement Sample Calculation	7
6.0	MEASUREMENT UNCERTAINTY	8
7.0	TEST EQUIPMENT CALIBRATION DATA.....	9
8.0	TEST DATA	10
8.1	Summary	10
8.2	Occupied Bandwidth Measurement	11
8.3	Conducted Output Power Measurement.....	17
8.4	In-Band Emissions and Radiated Spurious Emissions – Below 1GHz	20
8.5	Frequency Stability / Temperature Variation.....	41
9.0	CONCLUSION	43

FCC ID: RS2SXEZR2	 MEASUREMENT REPORT (CERTIFICATION)		Approved by: Technical Manager
Test Report S/N: 1M2303100028-03.RS2	Test Dates: 3/20/2023 - 3/30/2023	EUT Type: Satellite Radio with FM transmitter	Page 2 of 43

1.0 INTRODUCTION

1.1 Scope

Measurement and determination of electromagnetic emissions (EMC) of radio frequency devices including intentional and/or unintentional radiators for compliance with the technical rules and regulations of the Federal Communications Commission and Innovation, Science and Economic Development Canada.

1.2 Element Test Location

These measurement tests were conducted at the Element Laboratory located at 7185 Oakland Mills Road, Columbia, MD 21046. The measurement facility is compliant with the test site requirements specified in ANSI C63.4-2014.

1.3 Test Facility / Accreditations

Measurements were performed at Element Lab located in Columbia, MD 21046, U.S.A.

- Element Washington DC LLC is an ISO 17025-2017 accredited test facility under the American Association for Laboratory Accreditation (A2LA) with Certificate number 2041.01 for Specific Absorption Rate (SAR), Hearing Aid Compatibility (HAC) testing, where applicable, and Electromagnetic Compatibility (EMC) testing for FCC and Innovation, Science, and Economic Development Canada rules.
- Element Washington DC LLC TCB is a Telecommunication Certification Body (TCB) accredited to ISO/IEC 17065-2012 by A2LA (Certificate number 2041.03) in all scopes of FCC Rules and ISED Standards (RSS).
- Element Washington DC LLC facility is a registered (2451B) test laboratory with the site description on file with ISED.
- Element Washington DC LLC is a Recognized U.S. Certification Assessment Body (CAB # US0110) for ISED Canada as designated by NIST under the U.S. and Canada Mutual Recognition Agreements (MRAs).

FCC ID: RS2SXEZR2	 MEASUREMENT REPORT (CERTIFICATION)		Approved by: Technical Manager
Test Report S/N: 1M2303100028-03.RS2	Test Dates: 3/20/2023 - 3/30/2023	EUT Type: Satellite Radio with FM transmitter	Page 3 of 43

2.0 PRODUCT INFORMATION

2.1 Equipment Description

The Equipment Under Test (EUT) is the **Sirius XM Radio Inc. Satellite Radio with FM transmitter FCC ID: RS2SXZR2**. The test data contained in this report pertains only to the emissions due to the digital circuitry of the EUT.

To enable the FM transmitter, an FM Direct Adapter-FMDA25 must be plugged into the SXM Tuner/Adapter (Smart CLA) which is powered by a standard 12VDC power source (via a cigarette lighter adapter).

Test Device Serial No.: AWWHBERZ

2.2 Device Capabilities

This device contains the following capabilities:

FM Transmitter

2.3 Test Configuration

The Sirius XM Satellite Radio with FM transmitter FCC ID: RS2SXZR2 was tested per the guidance of ANSI C63.10-2013. Below is a brief list of each configuration set-up, per SiriusXM Onyx EZR SOW.

Test Configuration #	Emissions Tested	Description
5	Conducted	Receiver (EUT) under test with PowerConnect Car Dock & iFMCLA
6	Conducted	Receiver (EUT) under test with Xpress Car Dock & FM Direct Adapter (XMFM1)
7	Radiated	Receiver (EUT) under test with FEA unit
8	Radiated	Receiver (EUT) under test with Power Connect
9	Radiated	Receiver (EUT) under test with Xpress Car Dock & SureConnect Apdater
10	Conducted	Receiver (EUT) under test with Bias-Tee

Table 2-1. Test Configuration Description

For more information please see Section 8.0 for test data and the test setup photos document for the test setup photographs.

2.4 Software and Firmware

The test was conducted with software/firmware version 00.35 installed on the EUT.

2.5 EMI Suppression Device(s)/Modifications

No EMI suppression device(s) were added and no modifications were made during testing.

FCC ID: RS2SXZR2		MEASUREMENT REPORT (CERTIFICATION)	Approved by: Technical Manager
Test Report S/N: 1M2303100028-03.RS2	Test Dates: 3/20/2023 - 3/30/2023	EUT Type: Satellite Radio with FM transmitter	Page 4 of 43

3.0 DESCRIPTION OF TESTS

3.1 Evaluation Procedure

The measurement procedure described in the American National Standard for Methods of Measurement of Radio-Noise Emission from Low-Voltage Electrical and Electronic Equipment in the Range of 9kHz to 40GHz (ANSI C63.4-2014) was used in the measurement of the EUT.

Deviation from measurement procedure.....None

3.2 Radiated Emissions

The radiated test facilities consisted of an indoor 3 meter semi-anechoic chamber used for final measurements and exploratory measurements, when necessary. The measurement area is contained within the semi-anechoic chamber which is shielded from any ambient interference. The test site inside the chamber is a 6m x 5.2m elliptical, obstruction-free area in accordance with Clause 5, Figure 5.7 of ANSI C63.4-2014. A raised turntable is used for radiated measurement. It is a continuously rotatable, remote-controlled, metallic turntable and 2 meters (6.56 ft.) in diameter. The turn table is flush with the raised floor of the chamber in order to maintain its function as a ground plane. Absorbers are arranged on the floor between the turn table and the antenna mast in such a way so as to maximize the reduction of reflections for measurements above 1GHz. . An 80cm tall test table made of Styrodur is placed on top of the turn table. For measurements above 1GHz, an additional Styrodur pedestal is placed on top of the test table to bring the total table height to 1.5m.

For all measurements, the spectrum was scanned through all EUT azimuths and from 1 to 4 meter receive antenna height using a broadband antenna from 30MHz up to the upper frequency shown in 15.33(b)(1) depending on the highest frequency generated or used in the device or on which the device operates or tunes. For frequencies above 1GHz, linearly polarized double ridge horn antennas were used. For frequencies below 30MHz, a calibrated loop antenna was used. When exploratory measurements were necessary, they were performed at 1 meter test distance inside the semi-anechoic chamber using broadband antennas, broadband amplifiers, and spectrum analyzers to determine the frequencies and modes producing the maximum emissions. Sufficient time for the EUT, support equipment, and test equipment was allowed in order for them to warm up to their normal operating condition. The test set-up was placed on top of the 1 x 1.5 meter table. The EUT, support equipment, and interconnecting cables were arranged and manipulated to maximize each emission. Appropriate precaution was taken to ensure that all emissions from the EUT were maximized and investigated. The system configuration, mode of operation, turntable azimuth, and receive antenna height was noted for each frequency found.

Final measurements were made in the semi-anechoic chamber using calibrated, linearly polarized broadband and horn antennas. The test setup was configured to the setup that produced the worst case emissions. The spectrum analyzer was set to investigate all frequencies required for testing to compare the highest radiated disturbances with respect to the specified limits. The turntable containing the EUT was rotated through 360 degrees and the height of the receive antenna was varied 1 to 4 meters and stopped at the azimuth and height producing the maximum emission. Each emission was maximized by changing the orientation of the EUT through three orthogonal planes and changing the polarity of the receive antenna, whichever produced the worst-case emissions.

3.3 Environmental Conditions

The temperature is controlled within range of 15°C to 35°C. The relative humidity is controlled within range of 10% to 75%. The atmospheric pressure is monitored within the range 86-106kPa (860-1060mbar).

FCC ID: RS2SXZR2	 MEASUREMENT REPORT (CERTIFICATION)		Approved by: Technical Manager
Test Report S/N: 1M2303100028-03.RS2	Test Dates: 3/20/2023 - 3/30/20/23	EUT Type: Satellite Radio with FM transmitter	Page 5 of 43

4.0 ANTENNA REQUIREMENTS

Excerpt from §15.203 of the FCC Rules/Regulations:

“An intentional radiator antenna shall be designed to ensure that no antenna other than that furnished by the responsible party can be used with the device. The use of a permanently attached antenna or of an antenna that uses a unique coupling to the intentional radiator shall be considered sufficient to comply with the provisions of this section.”

- The FM transmit antenna used with the Satellite Radio uses a unique coupling.

Conclusion:

The **Sirius XM Satellite Radio with FM transmitter FCC ID: RS2SXZR2** unit complies with the requirement of §15.203.

FCC ID: RS2SXZR2	 MEASUREMENT REPORT (CERTIFICATION)		Approved by: Technical Manager
Test Report S/N: 1M2303100028-03.RS2	Test Dates: 3/20/2023 - 3/30/2023	EUT Type: Satellite Radio with FM transmitter	Page 6 of 43

5.0 SAMPLE CALCULATIONS

5.1 Conducted Emission Measurement Sample Calculation

@ 20.3 MHz

Class B limit	= 60.0 dB μ V (Quasi-peak limit)
Reading	= - 57.8 dBm (calibrated quasi-peak level)
Convert to dB μ V	= - 57.8 + 107 = 49.2 dB μ V
Margin	= 49.2 - 60.0 = - 10.8 dB
	= 10.8 dB below limit

5.2 Radiated Emission Measurement Sample Calculation

@ 66.7 MHz

Class B limit	= 100 μ V/m = 40.0 dB μ V/m
Reading	= - 76.0 dBm (calibrated level)
Convert to dB μ V	= - 76.0 + 107 = 31.0 dB μ V
Antenna Factor + Cable Loss	= 5.8 dB/m
Total	= 36.8 dB μ V/m
Margin	= 36.8 - 40.0 = - 3.2 dB
	= 3.2 dB below limit

Note:

$$\text{Level [dB}\mu\text{V]} = 20 \log_{10} (\text{Level } [\mu\text{V/m}])$$

$$\text{Level [dB}\mu\text{V]} = \text{Level [dBm]} + 107$$

FCC ID: RS2SXEZR2		MEASUREMENT REPORT (CERTIFICATION)	Approved by: Technical Manager
Test Report S/N: 1M2303100028-03.RS2	Test Dates: 3/20/2023 - 3/30/2023	EUT Type: Satellite Radio with FM transmitter	Page 7 of 43

6.0 MEASUREMENT UNCERTAINTY

The measurement uncertainties shown below were calculated in accordance with the requirements of ANSI C63.4-2014. All measurement uncertainty values are shown with a coverage factor of $k = 2$ to indicate a 95% level of confidence. The measurement uncertainty shown below meets or exceeds the U_{CISPR} measurement uncertainty values specified in CISPR 16-4-2 and, thus, can be compared directly to specified limits to determine compliance.

Contribution	Expanded Uncertainty (\pm dB)
Radiated Disturbance (<1GHz)	4.98
Radiated Disturbance (>1GHz)	5.07

FCC ID: RS2SXEZR2		MEASUREMENT REPORT (CERTIFICATION)	Approved by: Technical Manager
Test Report S/N: 1M2303100028-03.RS2	Test Dates: 3/20/2023 - 3/30/20/23	EUT Type: Satellite Radio with FM transmitter	Page 8 of 43

7.0 TEST EQUIPMENT CALIBRATION DATA

Test Equipment Calibration is traceable to the National Institute of Standards and Technology (NIST). Measurements antennas used during testing were calibrated in accordance to the requirements of ANSI C63.5-2017.

Manufacturer	Model	Description	Cal Date	Cal Interval	Cal Due	Serial Number
Agilent	N9038A	MXE EMI Receiver	6/21/2022	Annual	6/21/2023	MY51210133
ETS-Lindgren	3117	Horn Antenna (1-18GHz)	4/20/2021	Biennial	4/20/2023	00125518
Rohde & Schwarz	ESU40	EMI Test Receiver (40GHz)	8/25/2022	Annual	8/25/2023	100348
Rohde & Schwarz	SFUNIT-Rx	Shielded Filter Unit	1/12/2023	Annual	1/12/2024	102134
Solar Electronics	8012-50-R-24-BNC	Line Impedance Stabilization Network	9/21/2022	Biennial	9/21/2024	0310233
Sunol	JB5	Bi-Log Antenna (30M - 5GHz)	8/30/2022	Biennial	8/30/2024	A051107

Table 7-1. Annual Test Equipment Calibration Schedule

FCC ID: RS2SXEZR2	 MEASUREMENT REPORT (CERTIFICATION)		Approved by: Technical Manager
Test Report S/N: 1M2303100028-03.RS2	Test Dates: 3/20/2023 - 3/30/20/23	EUT Type: Satellite Radio with FM transmitter	Page 9 of 43

8.0 TEST DATA

8.1 Summary

Company Name: Sirius XM Satellite Radio
 FCC ID: RS2SXEZR2
 FCC Classification: Low Power Communication Device Transmitter

Specification	RSS Section(s)	Test Description	Test Limit	Test Condition	Test Result	Reference
TRANSMITTER MODE (TX)						
15.239(a)	RSS-210 (B.9(a))	Occupied Bandwidth	< 200kHz and whole band shall lie wholly within frequency range 88-108MHz	CONDUCTED	PASS	Section 8.2
2.1046, ANSI C63.10 Annex J	RSS-Gen (6.12)	Conducted Power	-29dBm (per ANSI C63.10-2013)		PASS	Section 8.3
15.239(b), 15.209	RSS-210 (B.9(b))	In-Band Emissions	< 250 μ V/m within permitted 200 kHz band	RADIATED	PASS	Section 8.4
15.239(c), 15.209	RSS-210 (B.9(c))	Radiated Spurious Emission	Emissions outside of the specified band must meet the radiated limits detailed in 15.209		PASS	Section 8.4
2.1055	RSS-Gen (8.11)	Frequency Stability	All emissions must be kept within the band of operation		PASS	Section 8.6

Table 8-1. Summary of Test Results

Notes:

- 1) All modes of operation and data rates were investigated. The test results shown in the following sections represent the worst case emissions.
- 2) The analyzer plots shown in this section were all taken with a correction table loaded into the analyzer. The correction table was used to account for the losses of the cables and attenuators used as part of the system to connect the EUT to the analyzer at all frequencies of interest.
- 3) All antenna port conducted emissions testing was performed on a test bench with the antenna port of the EUT connected to the spectrum analyzer through calibrated cables and attenuators.

FCC ID: RS2SXEZR2			MEASUREMENT REPORT (CERTIFICATION)	Approved by: Technical Manager
Test Report S/N: 1M2303100028-03.RS2	Test Dates: 3/20/2023 - 3/30/2023	EUT Type: Satellite Radio with FM transmitter		Page 10 of 43

8.2 Occupied Bandwidth Measurement

§15.239(a), RSS-210 (B.9(a))

Test Overview and Limit

The Occupied Bandwidth is measured with a spectrum analyzer connected to the receive antenna while the EUT is operating in transmission mode at the appropriate frequency.

Emissions from the intentional radiator shall be confined within a band 200 kHz wide centered on the operating frequency. The 200kHz band shall lie wholly within the frequency range of 88 – 108 MHz.

Test Procedure Used

ANSI C63.10-2013 – Clauses 6.9.1 and 8.7

Test Settings

1. The signal analyzer's automatic bandwidth measurement capability was used to perform the Occupied Bandwidth measurement. The bandwidth measurement was not influenced by any intermediate power nulls in the fundamental emission.
2. Center frequency set to nominal EUT channel center frequency
3. Span set between two times and five times the OBW
4. RBW = 1 – 5% OBW
5. VBW \geq 3 x RBW
6. Detector = Peak
7. Trace mode = max hold
8. Sweep = auto couple
9. The trace was allowed to stabilize

FCC ID: RS2SXEZR2	 MEASUREMENT REPORT (CERTIFICATION)		Approved by: Technical Manager
Test Report S/N: 1M2303100028-03.RS2	Test Dates: 3/20/2023 - 3/30/20/23	EUT Type: Satellite Radio with FM transmitter	Page 11 of 43

V 9.0 02/01/2019

Test Setup

The EUT and measurement equipment were set up as shown in the diagram below.

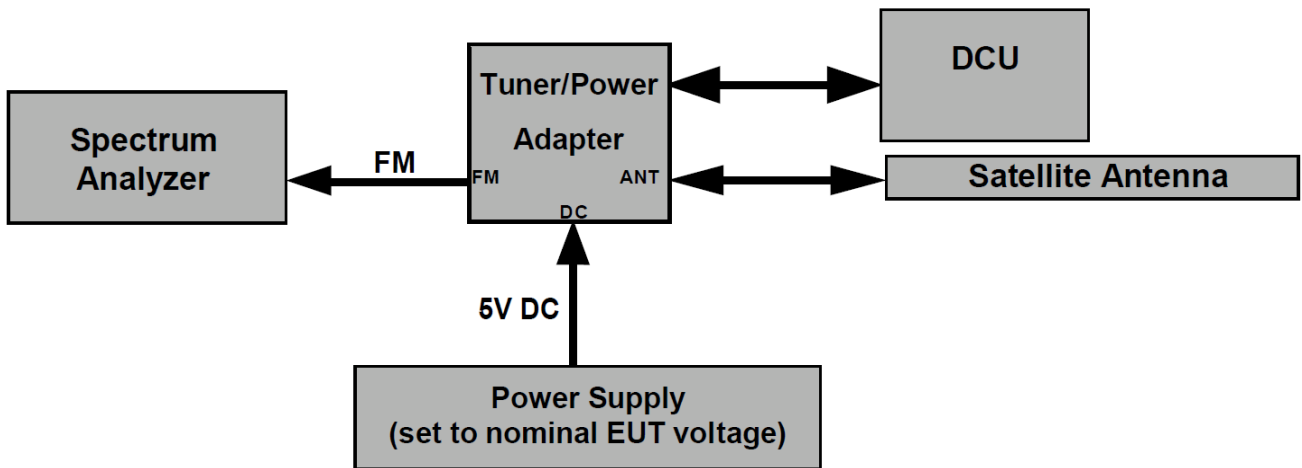

Figure 8-1. Test Instrument & Measurement Setup (Configuration #5 PowerConnect Car Dock & iFMCLA)

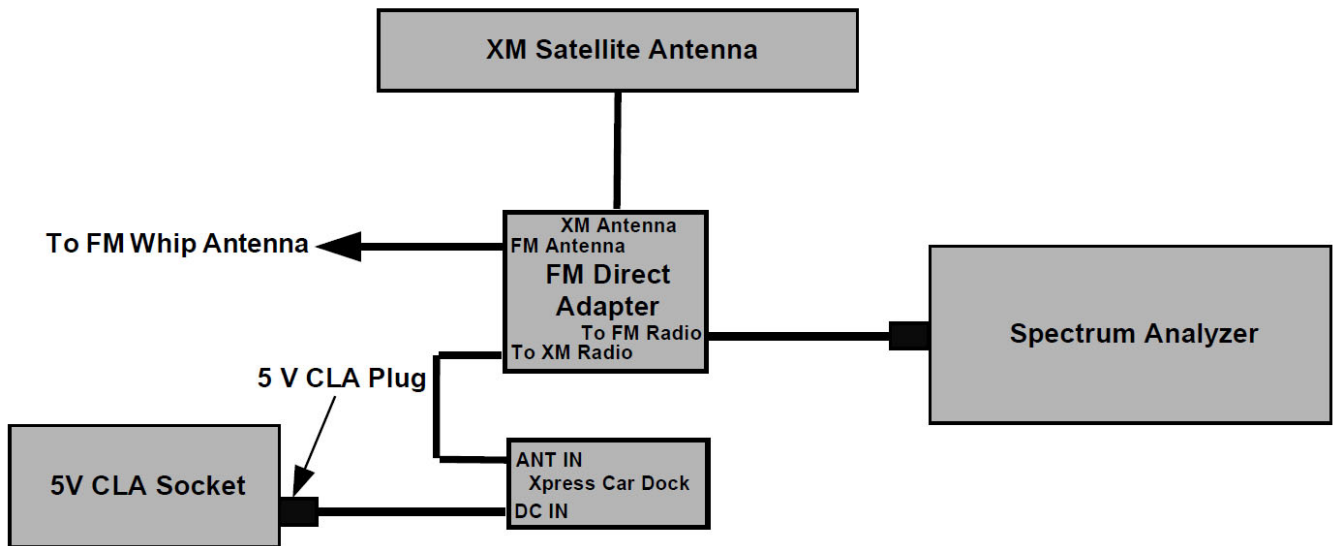



Figure 8-2. Test Instrument & Measurement Setup (Configuration #6 XpressCar Dock & FM Direct Adapter)

Test Notes

None

FCC ID: RS2SXEZR2	 MEASUREMENT REPORT (CERTIFICATION)		Approved by: Technical Manager
Test Report S/N: 1M2303100028-03.RS2	Test Dates: 3/20/2023 - 3/30/2023	EUT Type: Satellite Radio with FM transmitter	Page 12 of 43

Occupied Bandwidth Measurement – Configuration #5

Frequency [MHz]	Measured Bandwidth [kHz]	Maximum Bandwidth [kHz]	Pass / Fail
88.1	40.45	200.0	Pass
96.9	39.75	200.0	Pass
107.9	39.73	200.0	Pass

Table 8-2. Conducted Bandwidth Measurements

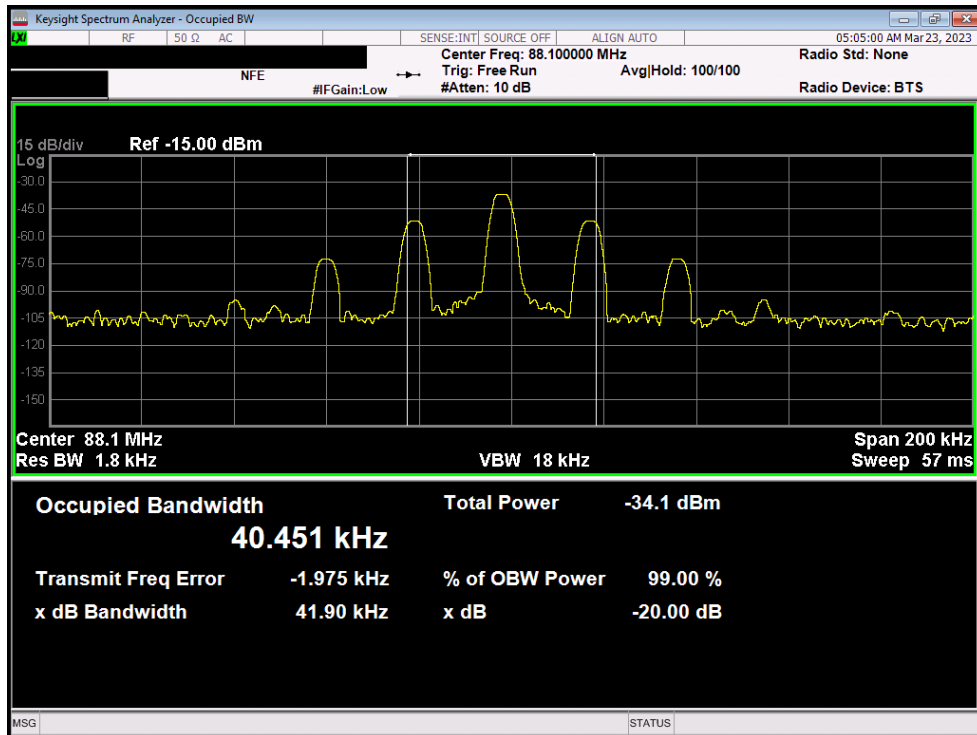

Plot 8-1. 20dB Bandwidth Plot (Low Channel – 88.1MHz)

FCC ID: RS2SXEZR2		MEASUREMENT REPORT (CERTIFICATION)	Approved by: Technical Manager
Test Report S/N: 1M2303100028-03.RS2	Test Dates: 3/20/2023 - 3/30/2023	EUT Type: Satellite Radio with FM transmitter	Page 13 of 43

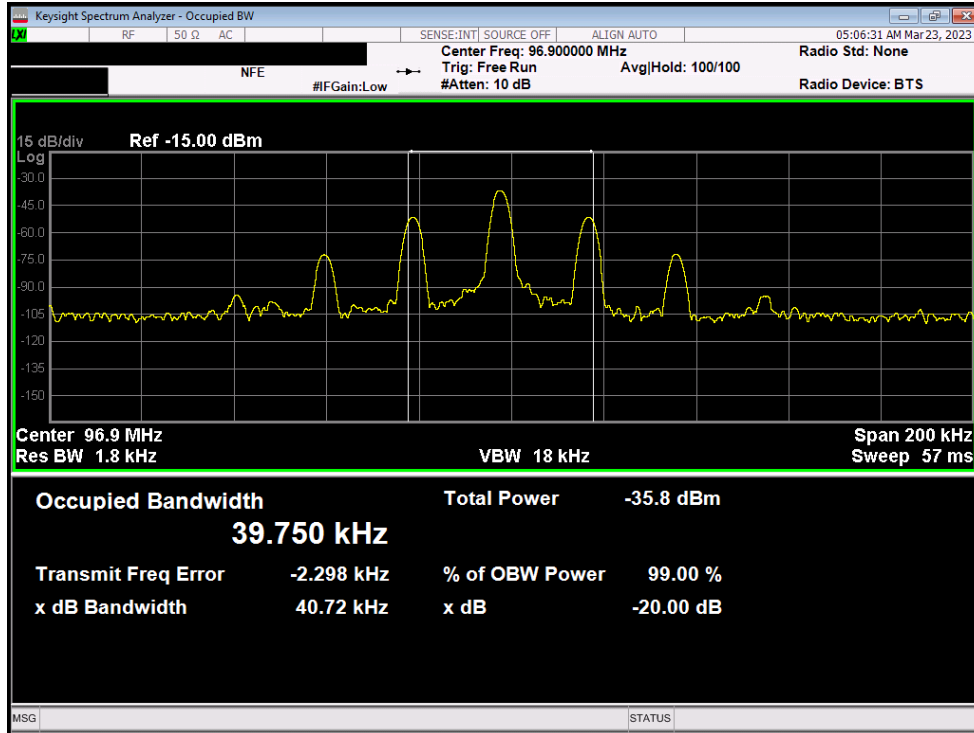

Plot 8-2. 20dB Bandwidth Plot (Mid Channel – 96.9MHz)

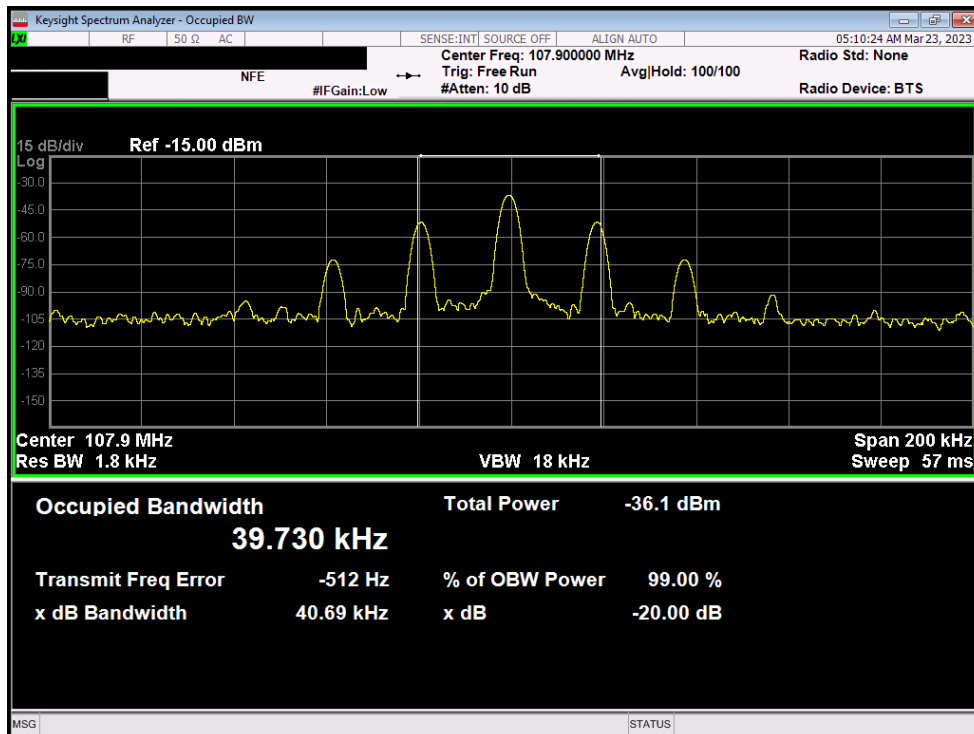

Plot 8-3. 20dB Bandwidth Plot (High Channel – 107.9MHz)

FCC ID: RS2SXEZR2		MEASUREMENT REPORT (CERTIFICATION)	Approved by: Technical Manager
Test Report S/N: 1M2303100028-03.RS2	Test Dates: 3/20/2023 - 3/30/2023	EUT Type: Satellite Radio with FM transmitter	Page 14 of 43

Occupied Bandwidth Measurement – Configuration #6

Frequency [MHz]	Measured Bandwidth [kHz]	Maximum Bandwidth [kHz]	Pass / Fail
88.1	194.8	200.0	Pass
96.9	193.3	200.0	Pass
107.9	196.6	200.0	Pass

Table 8-3. Conducted Bandwidth Measurements

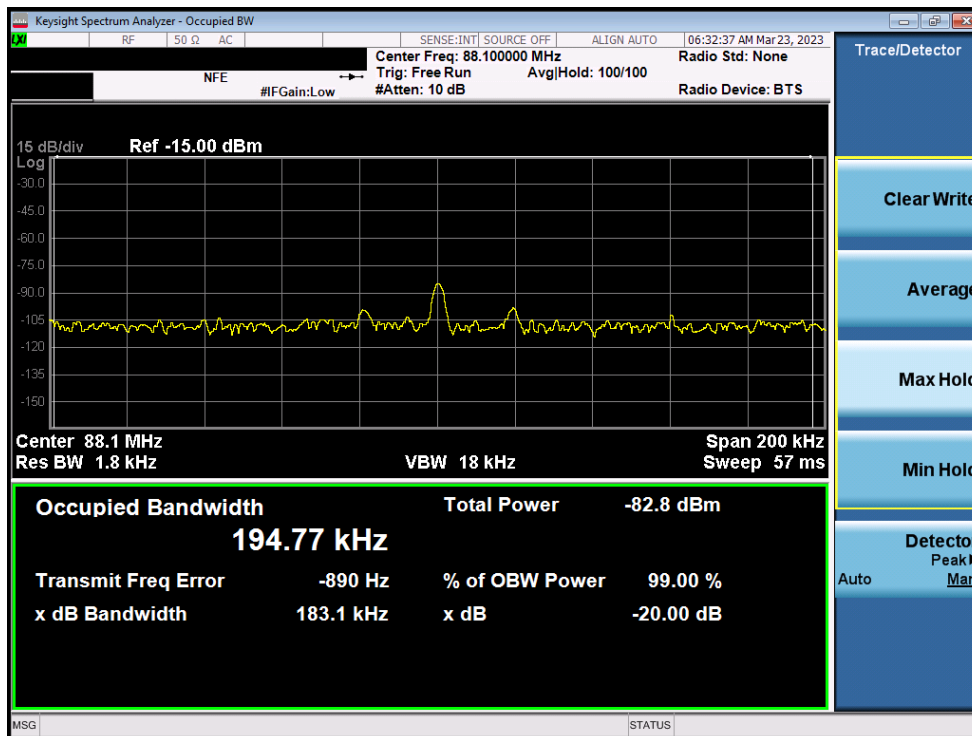

Plot 8-4. 20dB Bandwidth Plot (Low Channel – 88.1MHz)

FCC ID: RS2SXEZR2		MEASUREMENT REPORT (CERTIFICATION)	Approved by: Technical Manager
Test Report S/N: 1M2303100028-03.RS2	Test Dates: 3/20/2023 - 3/30/2023	EUT Type: Satellite Radio with FM transmitter	Page 15 of 43

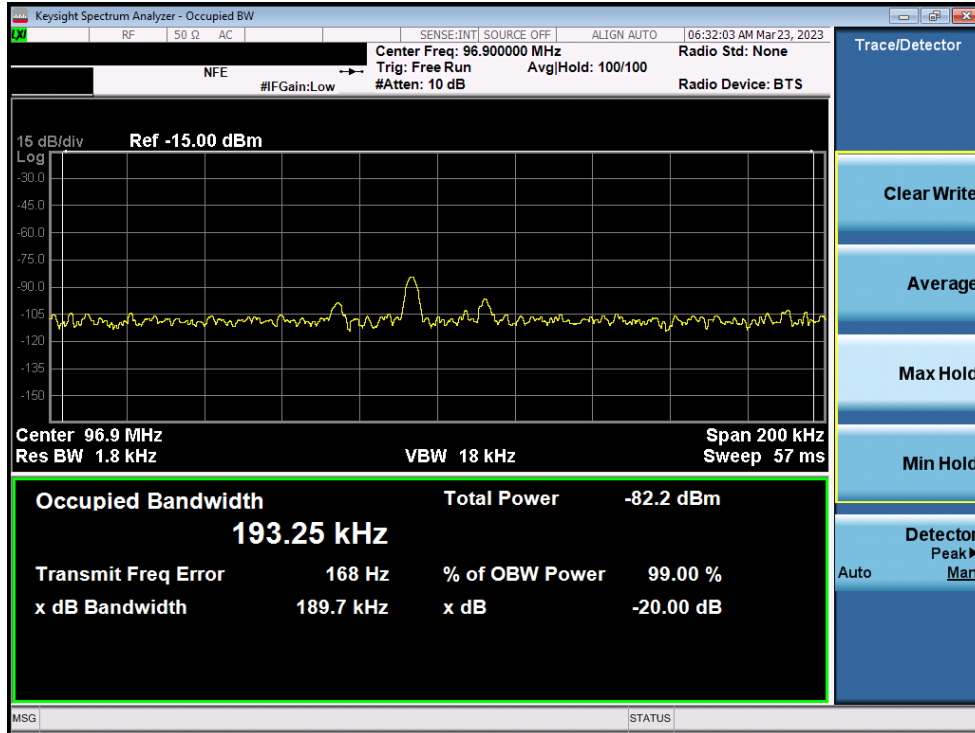

Plot 8-5. 20dB Bandwidth Plot (Mid Channel – 96.9MHz)

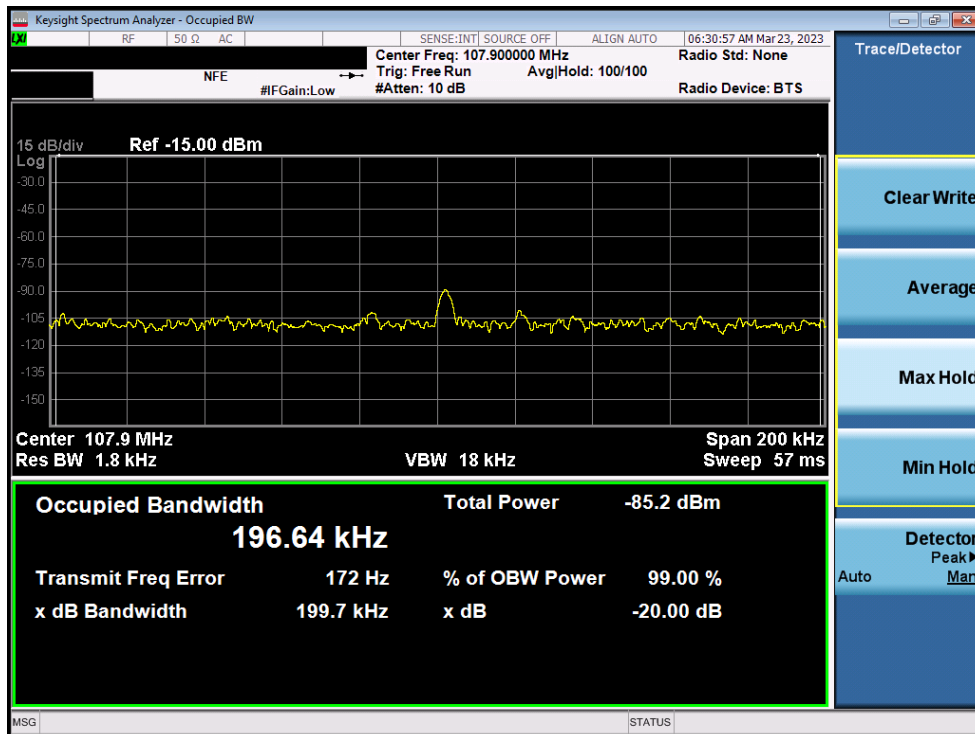

Plot 8-6. 20dB Bandwidth Plot (High Channel – 107.9MHz)

FCC ID: RS2SXEZR2		MEASUREMENT REPORT (CERTIFICATION)	Approved by: Technical Manager
Test Report S/N: 1M2303100028-03.RS2	Test Dates: 3/20/2023 - 3/30/20/23	EUT Type: Satellite Radio with FM transmitter	Page 16 of 43

8.3 Conducted Output Power Measurement

§2.1046

Test Overview

The FM transmitter was set to maximum audio output and was tuned between 88.1MHz and 107.9MHz. All other amplitude corrections of cables and attenuators have been loaded into the spectrum analyzer.

Test Procedure Used

ANSI C63.10-2013 – Clauses 8.5 and Annex J

Test Setup

The EUT and measurement equipment were set up as shown in the diagrams below.

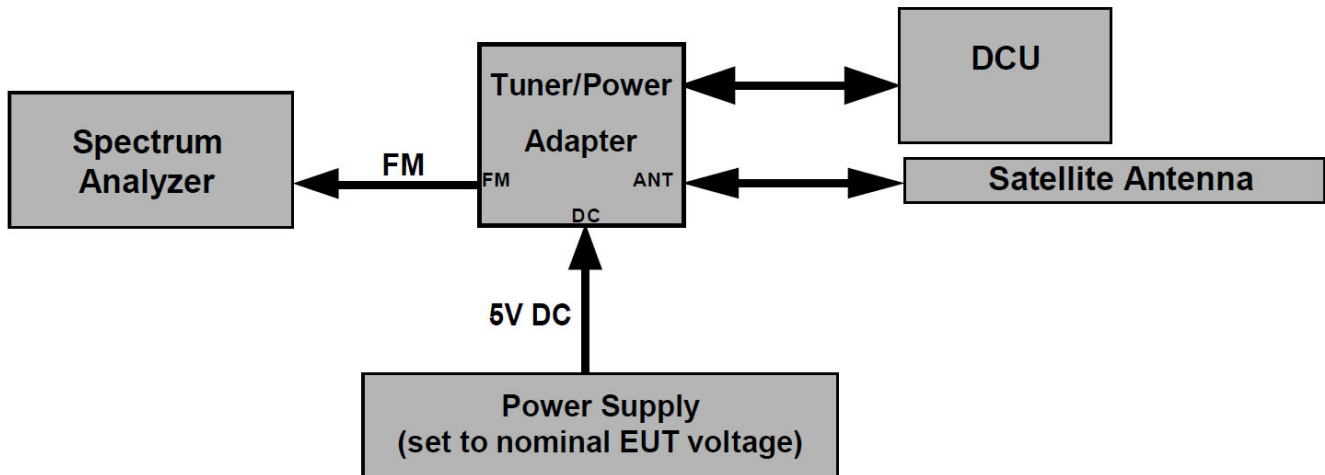

Figure 8-3. Test Instrument & Measurement Setup (Configuration #10)

Test Notes

None.

Frequency [MHz]	Mode	Conducted Power Test Results				
		Result [dBm]	Bias-T Loss	Corrected Result	Limit [dBm]	Margin [dB]
88.1	Live	-36.836	0.50	-36.34	-29.00	-7.34
96.9	Live	-36.803	0.50	-36.30	-29.00	-7.30
107.9	Live	-36.964	0.50	-36.46	-29.00	-7.46

Table 8-4. Conducted Output Power Measurements

FCC ID: RS2SXEZR2		MEASUREMENT REPORT (CERTIFICATION)	Approved by: Technical Manager
Test Report S/N: 1M2303100028-03.RS2	Test Dates: 3/20/2023 - 3/30/20/23	EUT Type: Satellite Radio with FM transmitter	Page 17 of 43

V 9.0 02/01/2019

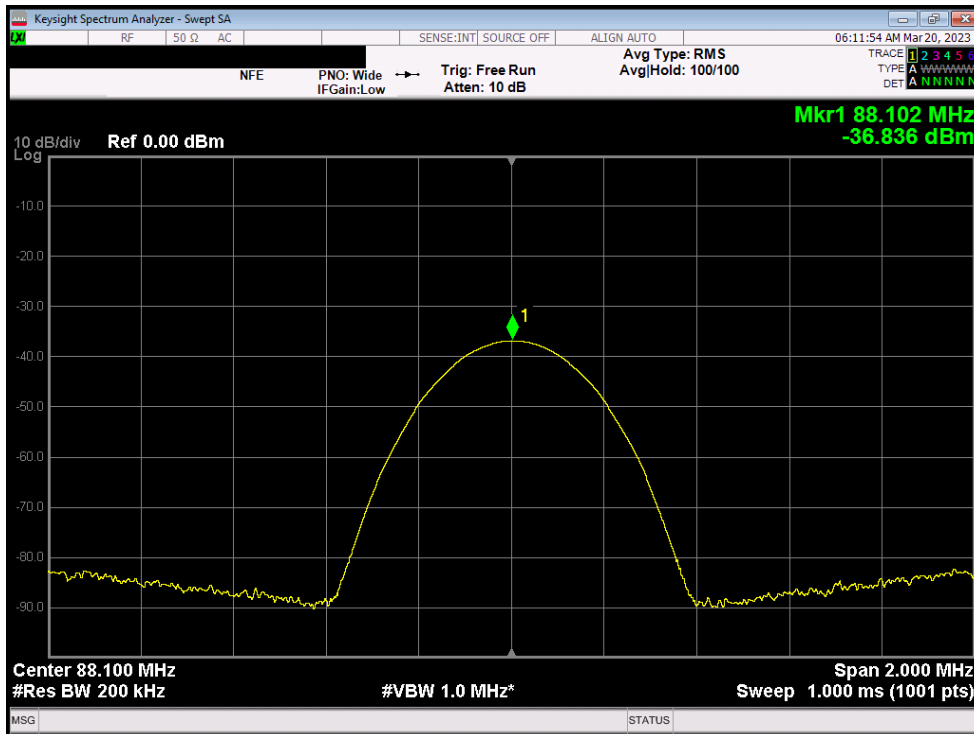

Plot 8-7. Peak Conducted Power (Low Channel – 88.1MHz)

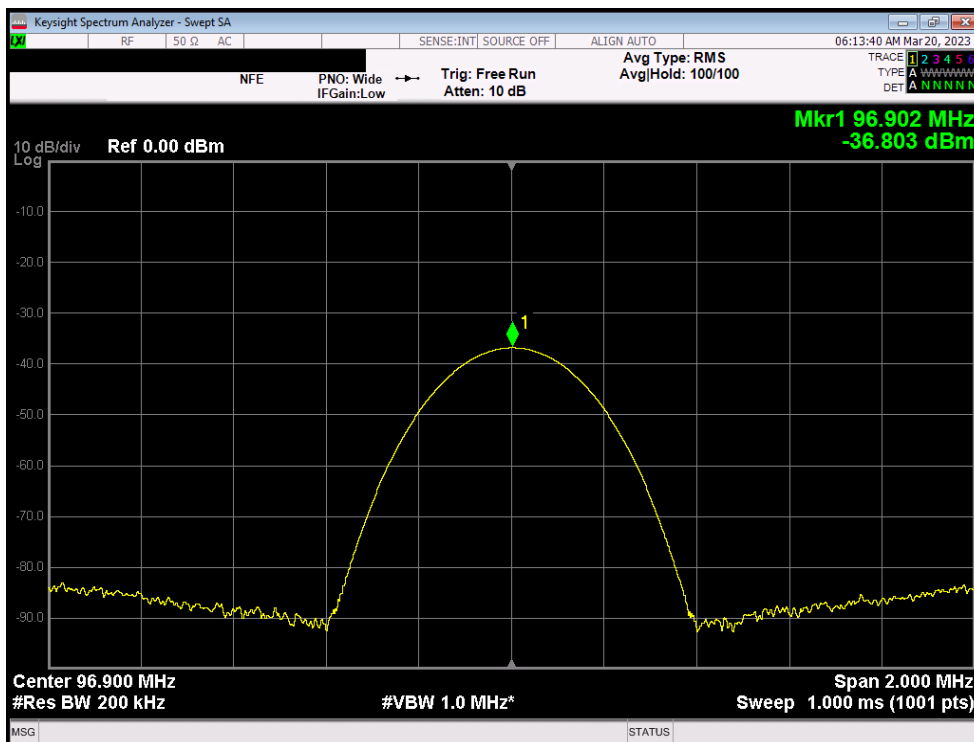

Plot 8-8. Peak Conducted Power (Channel – 96.9MHz)

FCC ID: RS2SXEZR2		MEASUREMENT REPORT (CERTIFICATION)	Approved by: Technical Manager
Test Report S/N: 1M2303100028-03.RS2	Test Dates: 3/20/2023 - 3/30/20/23	EUT Type: Satellite Radio with FM transmitter	Page 18 of 43

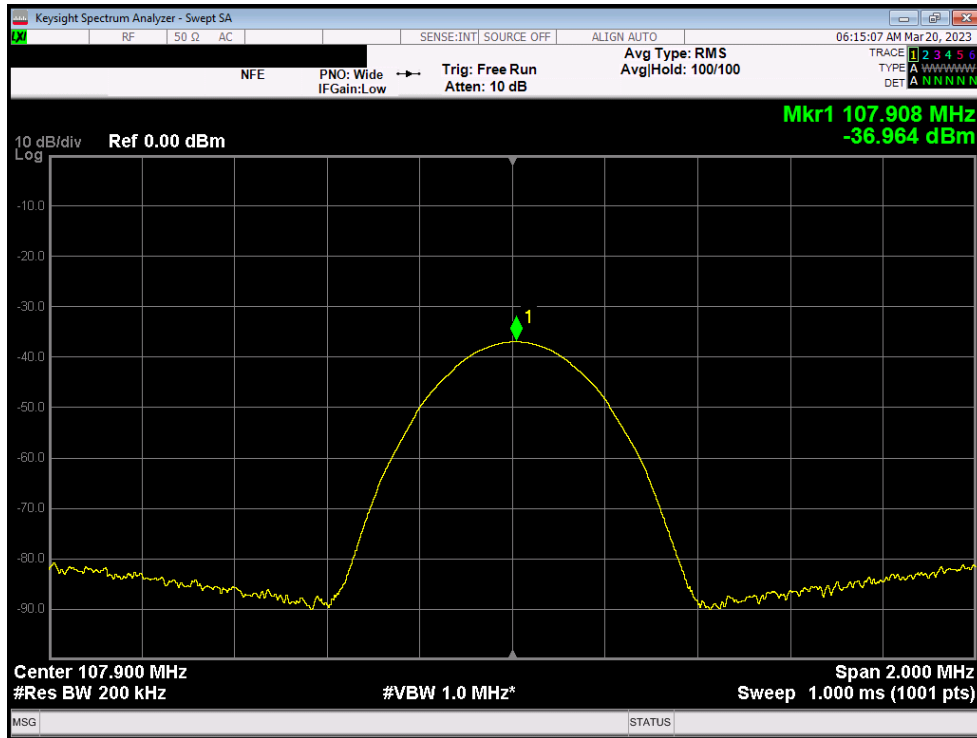

Plot 8-9. Peak Conducted Power (High Channel – 107.9MHz)

FCC ID: RS2SXEZR2	MEASUREMENT REPORT (CERTIFICATION)		Approved by: Technical Manager
Test Report S/N: 1M2303100028-03.RS2	Test Dates: 3/20/2023 - 3/30/2023	EUT Type: Satellite Radio with FM transmitter	Page 19 of 43

8.4 In-Band Emissions and Radiated Spurious Emissions – Below 1GHz §15.239(b), §15.209, RSS-210 (B.9(b)(c))

Test Overview and Limit

All out of band radiated spurious emissions are measured with a spectrum analyzer connected to a receive antenna while the EUT is operating at maximum power and at the appropriate frequencies. Only the radiated emissions of the configuration that produced the worst case emissions are reported in this section.

All in band emissions must not exceed 250 microvolts/meter within the permitted 200kHz band per Section 15.239(b) and RSS-210(B.9(b)).

All out of band emissions must not exceed the limits shown in Table 8-5 per FCC Part 15.209 and RSS-210(B.9(c)).

Frequency	Field Strength [$\mu\text{V/m}$]	Measured Distance [Meters]
0.009 – 0.490 MHz	2400/F (kHz)	300
0.490 – 1.705 MHz	24000/F (kHz)	30
1.705 – 30.00 MHz	30	30
30.00 – 88.00 MHz	100	3
88.00 – 216.0 MHz	150	3
216.0 – 960.0 MHz	200	3
Above 960.0 MHz	500	3

Table 8-5. Radiated Limits

Test Procedures Used

ANSI C63.10-2013 - Clauses 6.5 and 8.6

Test Settings

Quasi-Peak Field Strength Measurements

1. Analyzer center frequency was set to the frequency of the radiated spurious emission of interest
2. RBW = 120kHz (for emissions from 30MHz – 1GHz)
3. Detector = quasi-peak
4. Sweep time = auto couple
5. Trace mode = max hold
6. Trace was allowed to stabilize

FCC ID: RS2SXEZR2		MEASUREMENT REPORT (CERTIFICATION)	Approved by: Technical Manager
Test Report S/N: 1M2303100028-03.RS2	Test Dates: 3/20/2023 - 3/30/20/23	EUT Type: Satellite Radio with FM transmitter	Page 20 of 43

Test Setup

The EUT and measurement equipment were set up as shown in the diagram below.

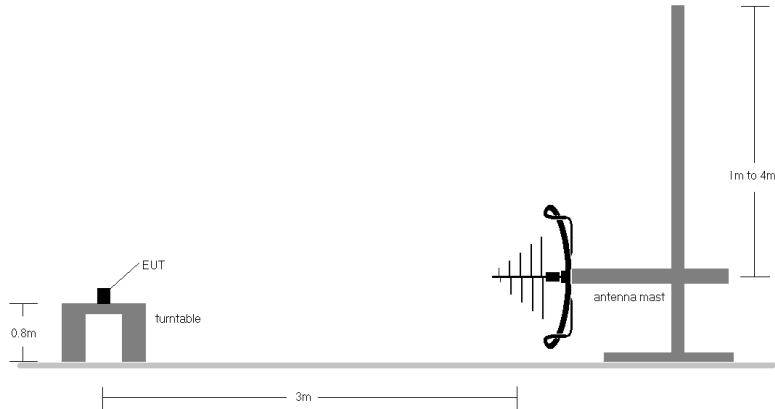

Figure 8-4. Test Instrument & Measurement Setup

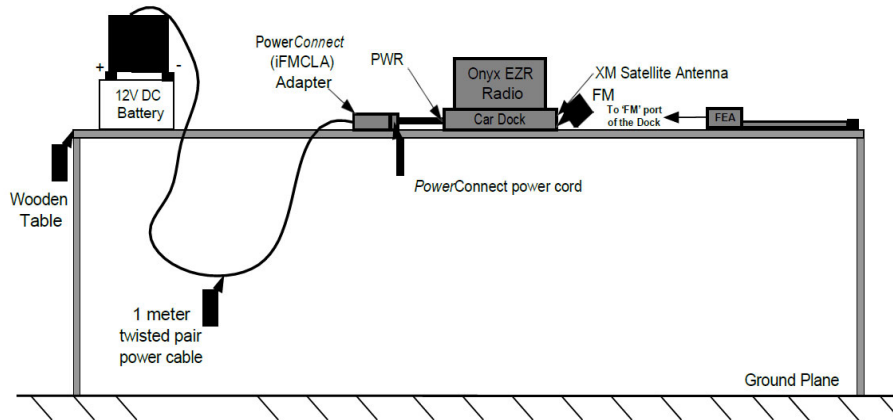

Figure 8-5. Test Instrument & Measurement Setup (Configuration #7 FEA unit)

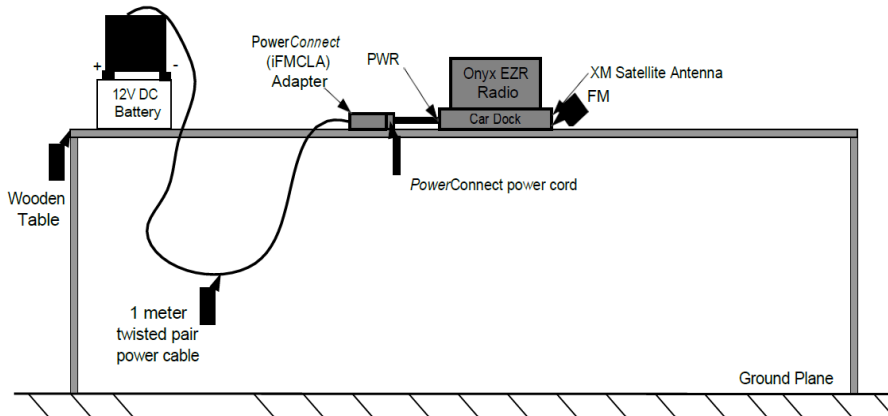

Figure 8-6. Test Instrument & Measurement Setup (Configuration #8 PowerConnect only)

FCC ID: RS2SXEZR2		MEASUREMENT REPORT (CERTIFICATION)	Approved by: Technical Manager
Test Report S/N: 1M2303100028-03.RS2	Test Dates: 3/20/2023 - 3/30/20/23	EUT Type: Satellite Radio with FM transmitter	Page 21 of 43

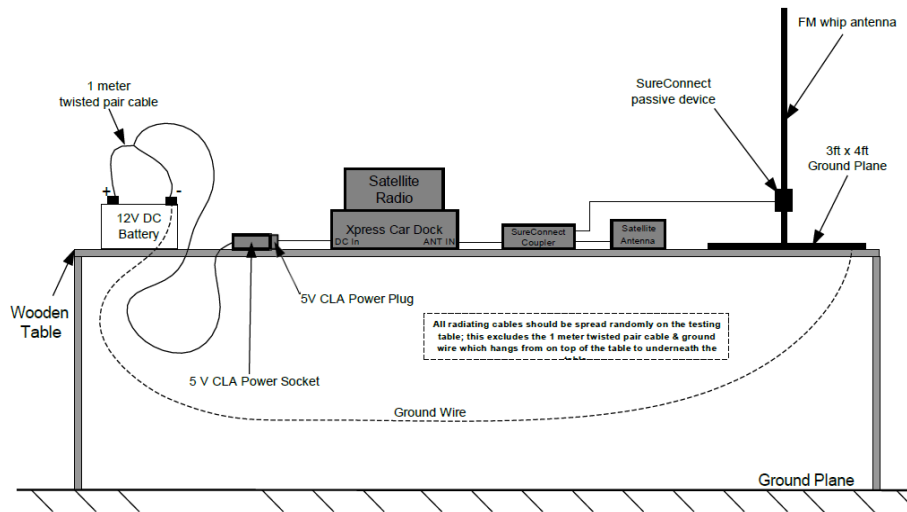

Figure 8-7. Test Instrument & Measurement Setup (Configuration #9 Xpress Car Dock & SureConnect Adapter)

Test Notes

1. All emissions lying in restricted bands specified in §15.205 are below the limit shown in Table 8-4.
2. The broadband receive antenna is manipulated through vertical and horizontal polarizations during the tests. The EUT is manipulated through three orthogonal planes.
3. This unit was tested while powered by a 12V DC power source (battery).
4. The spectrum is investigated using a peak detector. Final in-band measurements are recorded using an RMS detector, and final spurious emission measurements are recorded using a peak detector. The worst-case emissions are reported however emissions whose levels were not within 20dB of the respective limits were not reported.
5. Emissions were measured at a 3 meter test distance.
6. No spurious emissions were detected within 20dB of the limit below 30MHz.
7. The results recorded using the broadband antenna is known to correlate with the results obtained by using a tuned dipole with an acceptable degree of accuracy. The VSWR for the measurement antenna was found to be less than 2:1.
8. The wide spectrum spurious emissions plots shown on the following pages are used only for the purpose of emission identification.

FCC ID: RS2SXEZR2	 MEASUREMENT REPORT (CERTIFICATION)		Approved by: Technical Manager
Test Report S/N: 1M2303100028-03.RS2	Test Dates: 3/20/2023 - 3/30/2023	EUT Type: Satellite Radio with FM transmitter	Page 22 of 43

In-Band Emissions and Radiated Emissions – Configuration #7 Onyx EZR and FEA unit §15.239(b), §15.209, RSS-210 (B.9(b)(c))

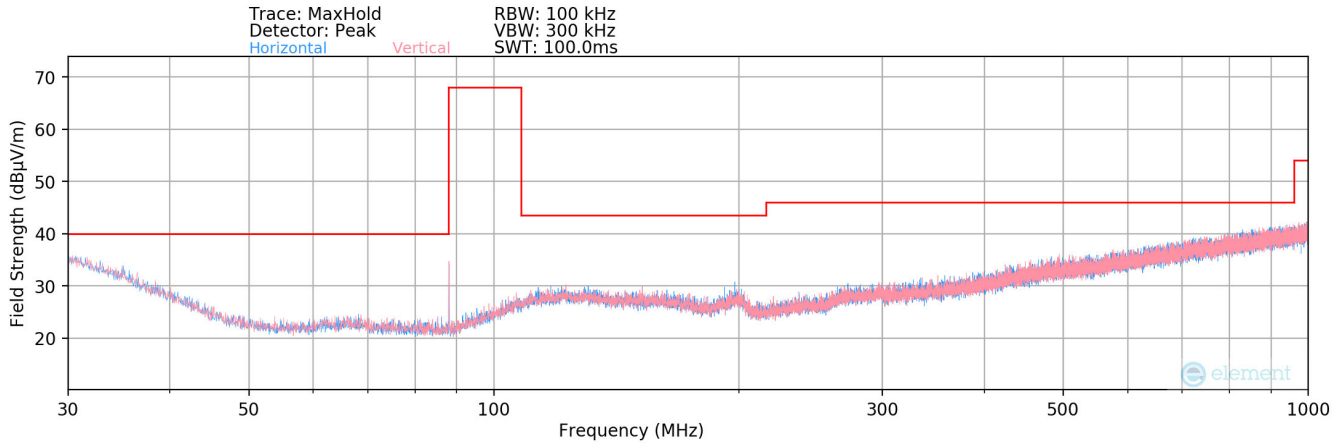

Plot 8-10. Radiated Spurious Plot below 1GHz (88.1MHz Configuration #7)

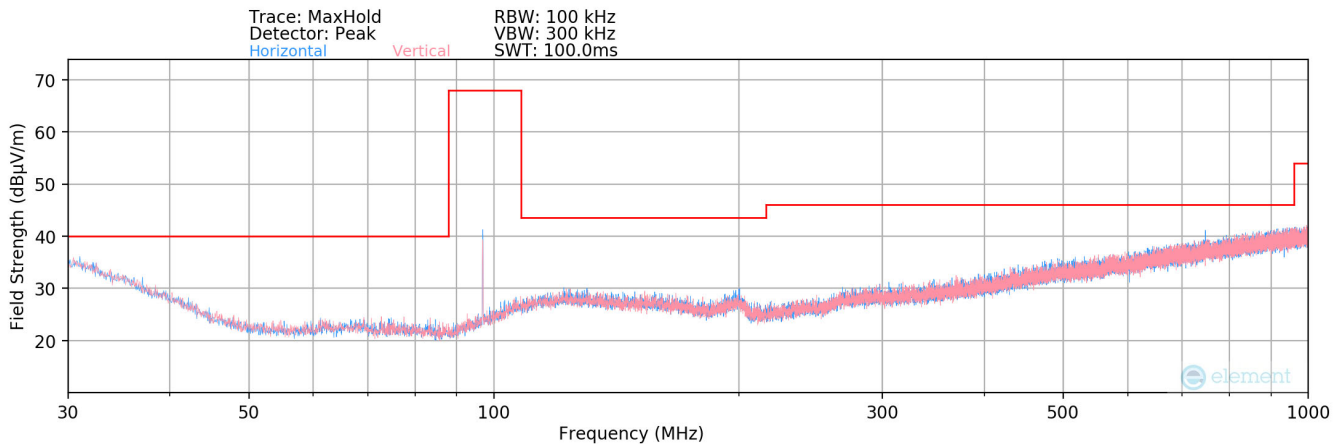

Plot 8-11. Radiated Spurious Plot below 1GHz (96.9MHz Configuration #7)

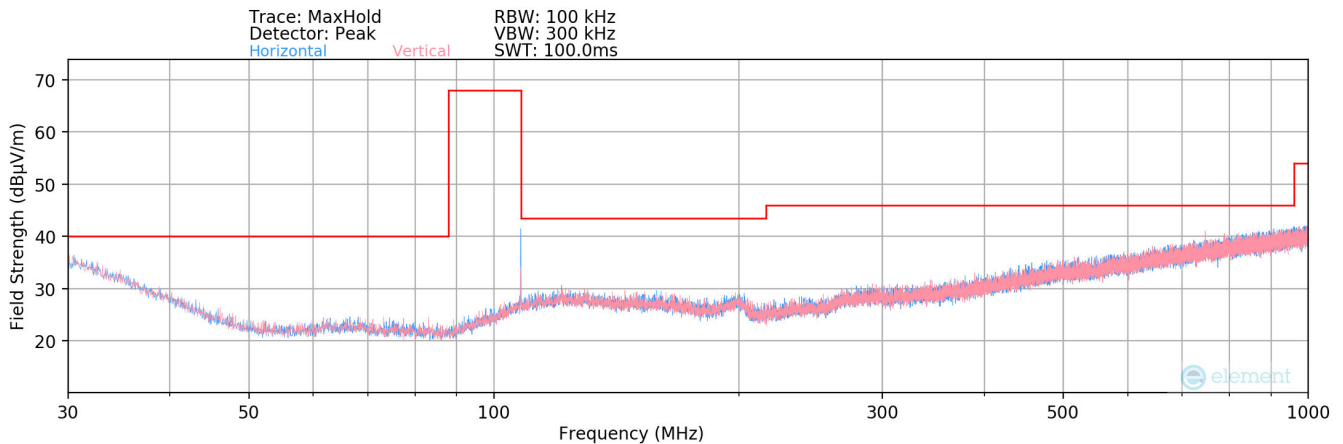

Plot 8-12. Radiated Spurious Plot below 1GHz (107.9MHz Configuration #7)

FCC ID: RS2SXEZR2		MEASUREMENT REPORT (CERTIFICATION)	Approved by: Technical Manager
Test Report S/N: 1M2303100028-03.RS2	Test Dates: 3/20/2023 - 3/30/2023	EUT Type: Satellite Radio with FM transmitter	Page 23 of 43

In-Band Emissions and Radiated Spurious Emissions – Configuration #7
§15.239(b), §15.209, RSS-210(B.9(b)(c))

Frequency [MHz]	Detector	Ant. Pol. [H/V]	Antenna Height [cm]	Turntable Azimuth [degree]	Analyzer Level [dBm]	AFCL [dB/m]	Field Strength [dBµV/m]	Limit [dBµV/m]	Margin [dB]
88.10	Average	H	103	102	-87.30	14.32	34.02	47.96	-13.94
88.10	Quasi-Peak	H	103	102	-86.62	14.32	34.70	67.96	-33.26
191.95	Quasi-Peak	H	-	-	-96.13	18.90	29.77	43.52	-13.75
328.25	Quasi-Peak	H	-	-	-96.60	21.74	32.14	46.02	-13.88
583.45	Quasi-Peak	H	-	-	-96.45	27.08	37.63	46.02	-8.39
663.65	Quasi-Peak	H	-	-	-96.24	28.17	38.93	46.02	-7.09
96.90	Average	H	102	84	-82.24	16.53	41.29	47.96	-6.67
96.90	Quasi-Peak	H	102	84	-81.74	16.53	41.79	67.96	-26.17
389.35	Quasi-Peak	H	-	-	-96.76	23.27	33.51	46.02	-12.51
615.45	Quasi-Peak	H	-	-	-96.10	27.23	38.13	46.02	-7.89
747.90	Quasi-Peak	H	-	-	-96.10	29.20	40.10	46.02	-5.92
107.90	Average	H	107	261	-84.54	19.04	41.50	47.96	-6.46
107.90	Quasi-Peak	H	107	261	-83.96	19.04	42.08	67.96	-25.88
432.61	Quasi-Peak	H	-	-	-97.14	24.60	34.46	46.02	-11.56
584.01	Quasi-Peak	H	-	-	-95.68	26.74	38.06	46.02	-7.96
732.59	Quasi-Peak	H	-	-	-95.62	29.14	40.52	46.02	-5.50

Table 8-6. Radiated Spurious Emissions below 1GHz, Configuration #7

FCC ID: RS2SXEZR2	 MEASUREMENT REPORT (CERTIFICATION)		Approved by: Technical Manager
Test Report S/N: 1M2303100028-03.RS2	Test Dates: 3/20/2023 - 3/30/20/23	EUT Type: Satellite Radio with FM transmitter	Page 24 of 43

In-Band Emissions and Radiated Spurious Emissions – Configuration #8 Onyx EZR – PowerConnect only
§15.239(b), §15.209, RSS-210(B.9(b)(c))

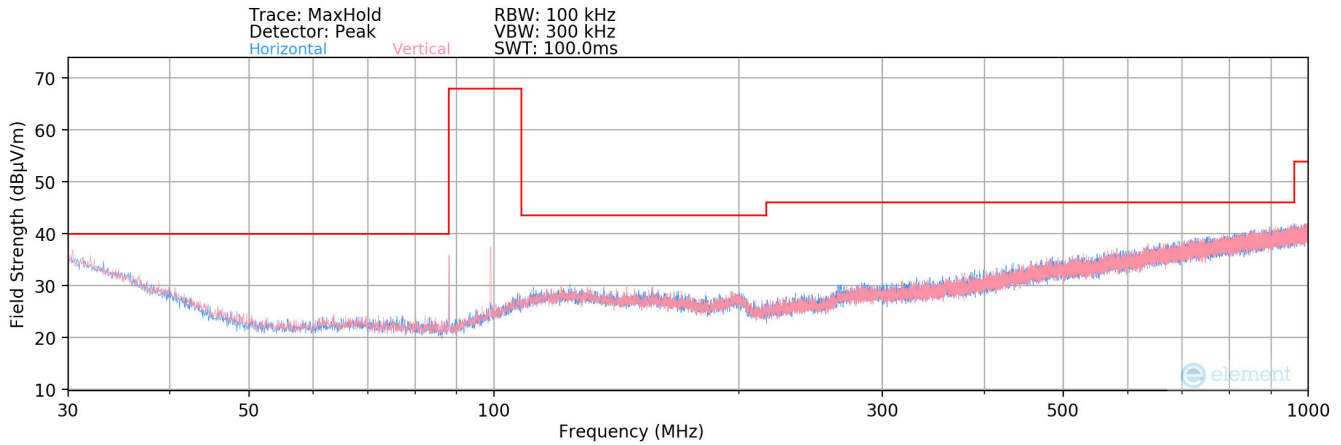

Plot 8-13. Radiated Spurious Plot below 1GHz (88.1MHz Configuration #8)

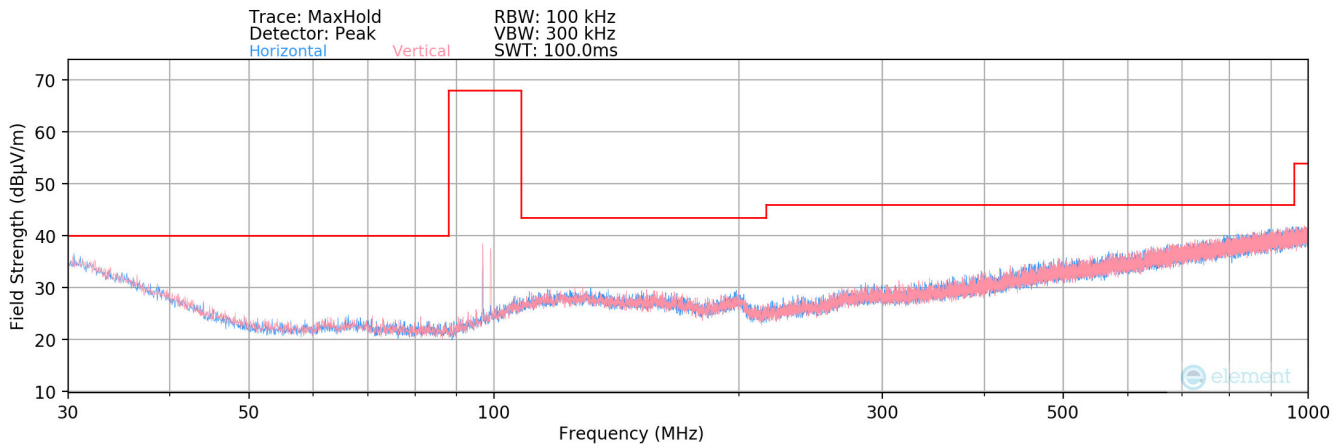

Plot 8-14. Radiated Spurious Plot below 1GHz (96.9MHz Configuration #8)

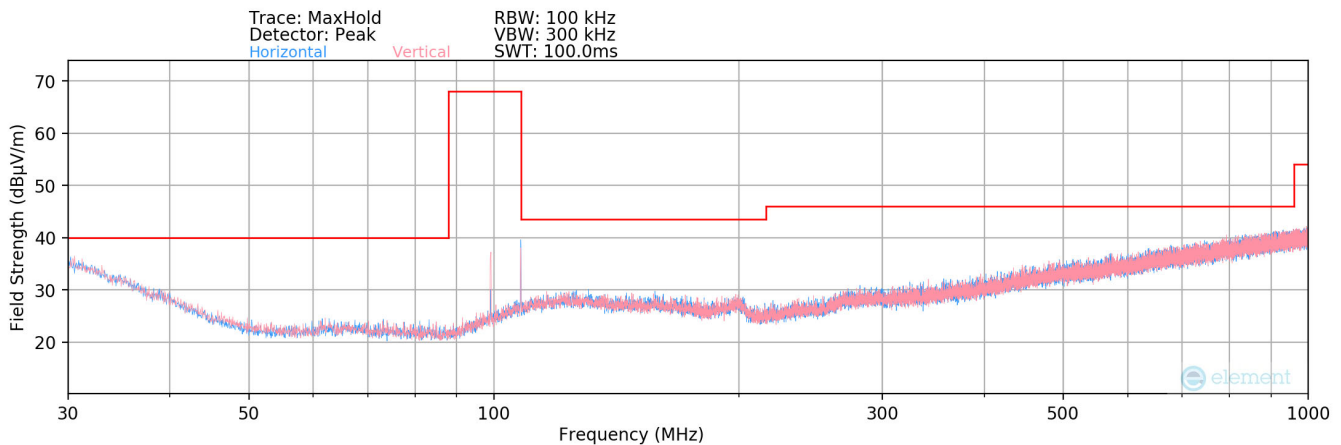

Plot 8-15. Radiated Spurious Plot below 1GHz (107.9MHz Configuration #8)

FCC ID: RS2SXEZR2		MEASUREMENT REPORT (CERTIFICATION)	Approved by: Technical Manager
Test Report S/N: 1M2303100028-03.RS2	Test Dates: 3/20/2023 - 3/30/20/23	EUT Type: Satellite Radio with FM transmitter	Page 25 of 43

In-Band Emissions and Radiated Spurious Emissions – Configuration #8
§15.239(b), §15.209, RSS-210(B.9(b)(c))

Frequency [MHz]	Detector	Ant. Pol. [H/V]	Antenna Height [cm]	Turntable Azimuth [degree]	Analyzer Level [dBm]	AFCL [dB/m]	Field Strength [dBµV/m]	Limit [dBµV/m]	Margin [dB]
88.10	Average	V	102	281	-88.08	14.32	33.24	47.96	-14.72
88.10	Quasi-Peak	V	102	281	-87.36	14.32	33.96	67.96	-34.00
99.10	Quasi-Peak	V	104	114	-90.76	16.81	33.05	43.52	-10.48
395.65	Quasi-Peak	V	-	-	-96.72	23.25	33.53	46.02	-12.49
504.40	Quasi-Peak	V	-	-	-96.24	26.05	36.81	46.02	-9.21
703.25	Quasi-Peak	V	-	-	-96.43	28.65	39.22	46.02	-6.80
96.90	Average	V	101	162	-84.89	16.53	38.64	47.96	-9.32
96.90	Quasi-Peak	V	101	162	-83.26	16.53	40.27	67.96	-27.69
99.10	Quasi-Peak	V	102	41	-89.16	16.81	34.65	43.52	-8.88
195.30	Quasi-Peak	V	-	-	-96.18	19.34	30.16	43.52	-13.36
330.70	Quasi-Peak	V	-	-	-96.24	21.75	32.51	46.02	-13.51
556.95	Quasi-Peak	V	-	-	-96.45	26.40	36.95	46.02	-9.07
107.90	Average	H	256	213	-86.43	16.83	37.40	47.96	-10.56
107.90	Quasi-Peak	H	256	213	-85.14	17.56	39.42	67.96	-28.54
99.05	Quasi-Peak	H	247	301	-93.75	21.51	34.76	43.52	-8.76
356.80	Quasi-Peak	H	-	-	-97.16	27.34	37.18	46.02	-8.84
645.95	Quasi-Peak	H	-	-	-96.10	31.49	42.39	46.02	-3.63

Table 8-7. Radiated Spurious Emissions below 1GHz, Configuration #8

FCC ID: RS2SXEZR2	 MEASUREMENT REPORT (CERTIFICATION)		Approved by: Technical Manager
Test Report S/N: 1M2303100028-03.RS2	Test Dates: 3/20/2023 - 3/30/2023	EUT Type: Satellite Radio with FM transmitter	Page 26 of 43

In-Band Emissions and Radiated Spurious Emissions – Configuration #9 Onyx EZR with Xpress Car Dock & SureConnect Adapter

§15.239(b), §15.209, RSS-210(B.9(b)(c))

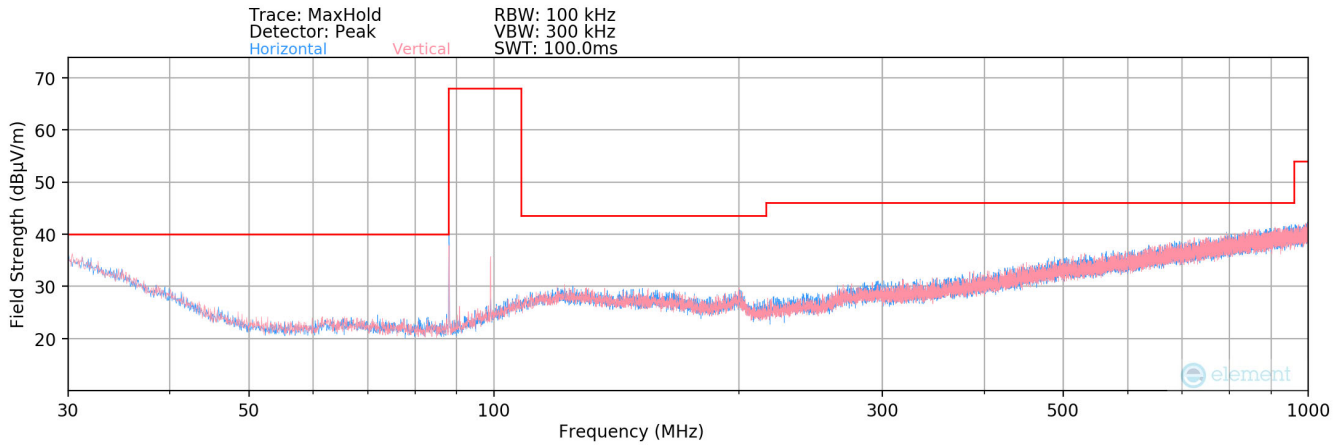

Plot 8-16. Radiated Spurious Plot below 1GHz (88.1MHz Configuration #9)

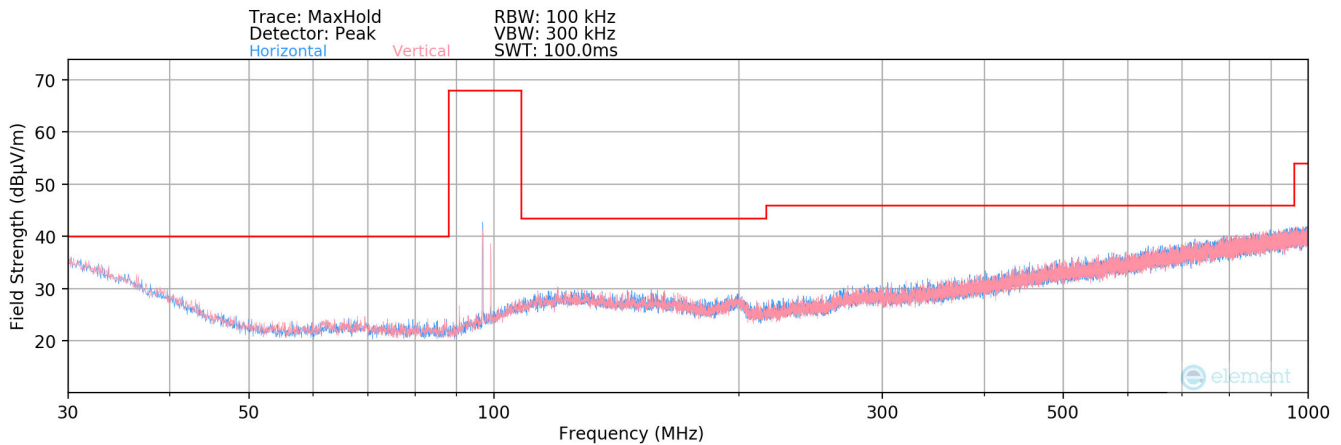

Plot 8-17. Radiated Spurious Plot below 1GHz (96.9MHz Configuration #9)

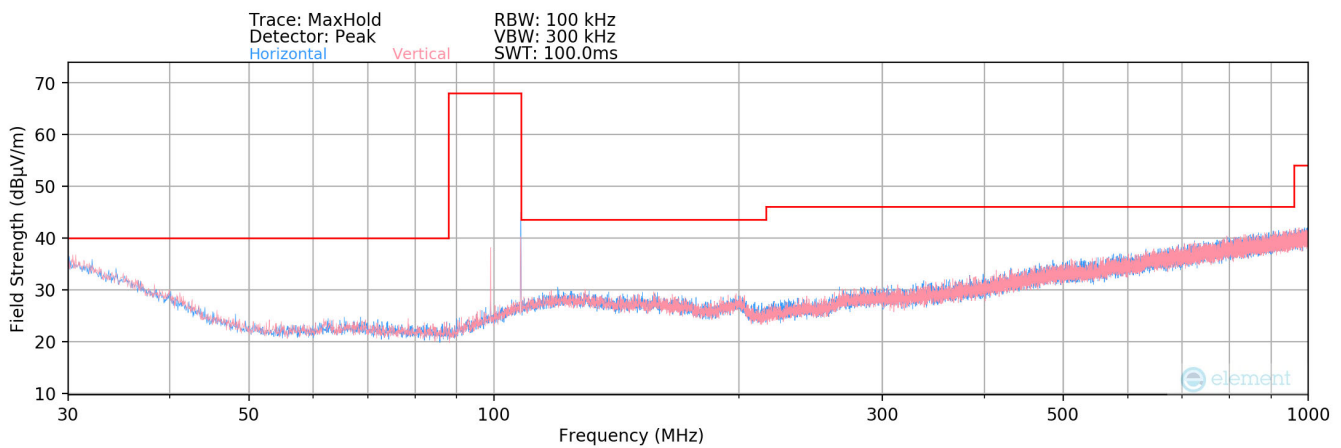

Plot 8-18. Radiated Spurious Plot below 1GHz (107.9MHz Configuration #9)

FCC ID: RS2SXEZR2		MEASUREMENT REPORT (CERTIFICATION)	Approved by: Technical Manager
Test Report S/N: 1M2303100028-03.RS2	Test Dates: 3/20/2023 - 3/30/20/23	EUT Type: Satellite Radio with FM transmitter	Page 27 of 43

In-Band Emissions and Radiated Spurious Emissions – Configuration #9
§15.239(b), §15.209, RSS-210(B.9(b)(c))

Frequency [MHz]	Detector	Ant. Pol. [H/V]	Antenna Height [cm]	Turntable Azimuth [degree]	Analyzer Level [dBm]	AFCL [dB/m]	Field Strength [dBµV/m]	Limit [dBµV/m]	Margin [dB]
88.10	Average	H	252	42	-80.64	14.32	40.68	47.96	-7.28
88.10	Quasi-Peak	H	252	42	-79.58	14.32	41.74	67.96	-26.22
99.05	Quasi-Peak	H	247	61	-94.98	16.78	28.80	43.52	-14.72
333.90	Quasi-Peak	H	-	-	-96.60	21.65	32.05	46.02	-13.97
464.50	Quasi-Peak	H	-	-	-96.81	25.09	35.28	46.02	-10.74
749.90	Quasi-Peak	H	-	-	-95.96	29.40	40.44	46.02	-5.59
96.90	Average	H	256	123	-80.78	16.53	42.75	47.96	-5.21
96.90	Quasi-Peak	H	256	123	-79.35	16.53	44.18	67.96	-23.78
99.05	Quasi-Peak	H	247	81	-95.20	16.78	28.58	43.52	-14.94
401.20	Quasi-Peak	H	-	-	-97.03	23.42	33.39	46.02	-12.63
718.95	Quasi-Peak	H	-	-	-95.49	28.84	40.35	46.02	-5.67
775.70	Quasi-Peak	H	-	-	-96.43	29.63	40.20	46.02	-5.82
107.90	Average	H	252	112	-81.11	19.04	44.93	47.96	-3.03
107.90	Quasi-Peak	H	252	112	-80.56	19.04	45.48	67.96	-22.48
99.10	Quasi-Peak	H	-	-	-95.47	16.81	28.34	43.52	-15.19
333.65	Quasi-Peak	H	-	-	-96.76	21.65	31.89	46.02	-14.13
686.25	Quasi-Peak	H	-	-	-96.49	28.53	39.04	46.02	-6.98
773.20	Quasi-Peak	H	-	-	-95.20	29.64	41.44	46.02	-4.58

Table 8-8. Radiated Spurious Emissions below 1GHz, Configuration #9

FCC ID: RS2SXEZR2	 MEASUREMENT REPORT (CERTIFICATION)		Approved by: Technical Manager
Test Report S/N: 1M2303100028-03.RS2	Test Dates: 3/20/2023 - 3/30/20/23	EUT Type: Satellite Radio with FM transmitter	Page 28 of 43

8.5 Radiated Spurious Emissions – Above 1GHz

§15.239(c), §15.209, RSS-210 (B.9(b)(c))

Test Overview and Limit

All out of band radiated spurious emissions are measured with a spectrum analyzer connected to a receive antenna while the EUT is operating at maximum power and at the appropriate frequencies. Only the radiated emissions of the configuration that produced the worst case emissions are reported in this section.

All out of band emissions appearing in a restricted band as specified in Section 15.205 of the Title 47 CFR must not exceed the limits shown in Table 8-9 per FCC Part 15.209 and RSS-210(B.9(c)).

Frequency	Field Strength [$\mu\text{V/m}$]	Measured Distance [Meters]
Above 960.0 MHz	500	3

Table 8-9. Radiated Limits

Test Procedures Used

ANSI C63.10-2013 – Clauses 6.6 and 8.6

Test Settings

1. Analyzer center frequency was set to the frequency of the radiated spurious emission of interest
2. RBW = 1MHz
3. VBW = 3MHz
4. Detector = peak
5. Sweep time = auto couple
6. Trace mode = max hold
7. Trace was allowed to stabilize

FCC ID: RS2SXEZR2	 MEASUREMENT REPORT (CERTIFICATION)		Approved by: Technical Manager
Test Report S/N: 1M2303100028-03.RS2	Test Dates: 3/20/2023 - 3/30/2023	EUT Type: Satellite Radio with FM transmitter	Page 29 of 43

Test Setup

The EUT and measurement equipment were set up as shown in the diagram below.

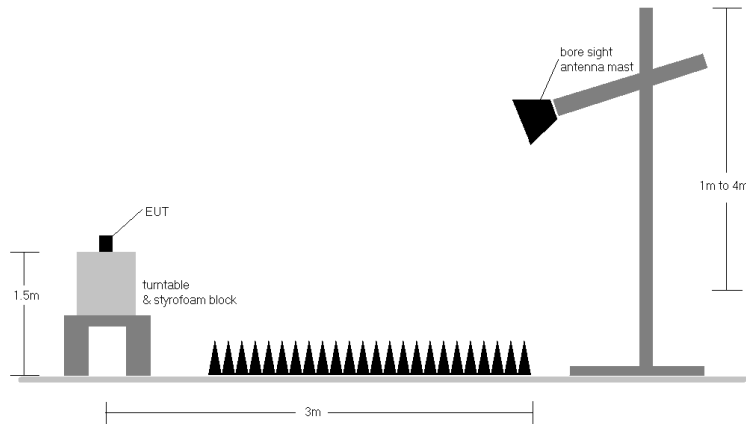

Figure 8-8. Test Instrument & Measurement Setup

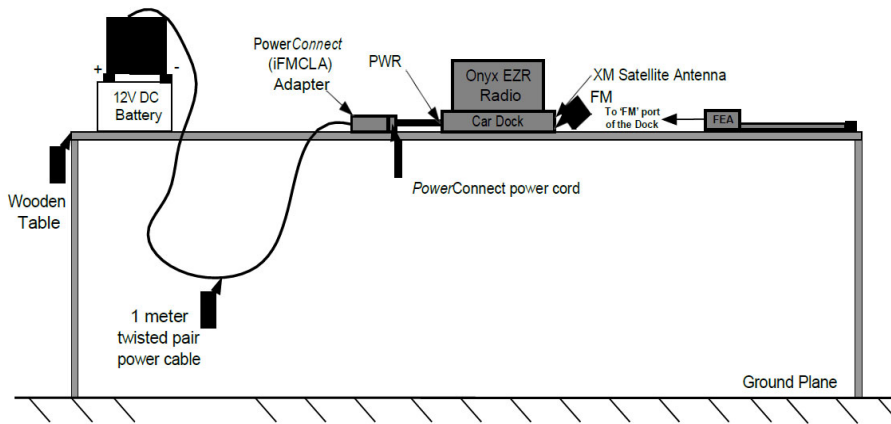

Figure 8-9. Test Instrument & Measurement Setup (Configuration #7 FEA unit)

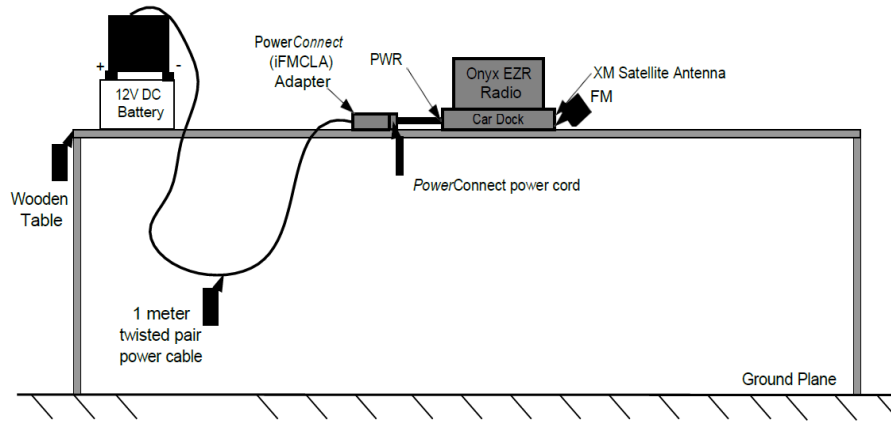



Figure 8-10. Test Instrument & Measurement Setup (Configuration #8 PowerConnect only)

FCC ID: RS2SXEZR2		MEASUREMENT REPORT (CERTIFICATION)	Approved by: Technical Manager
Test Report S/N: 1M2303100028-03.RS2	Test Dates: 3/20/2023 - 3/30/20/23	EUT Type: Satellite Radio with FM transmitter	Page 30 of 43

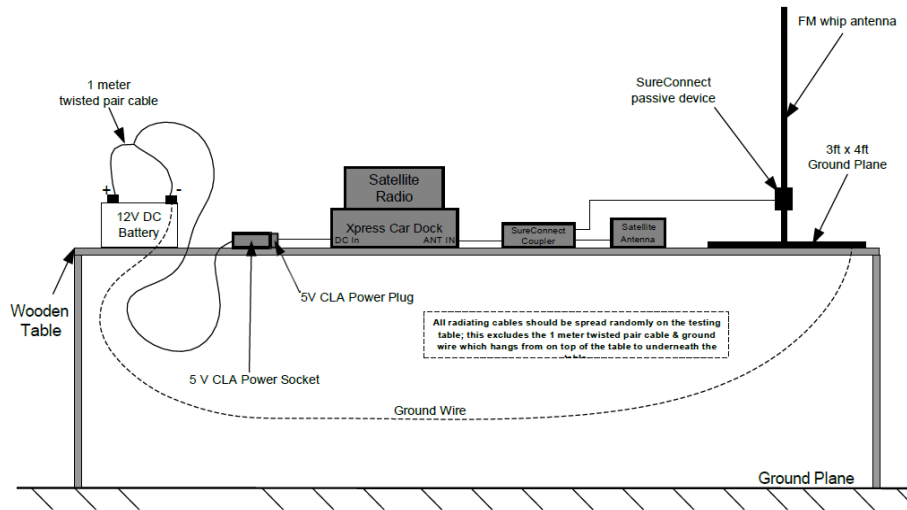

Figure 8-11. Test Instrument & Measurement Setup (Configuration #9 Xpress Car Dock & SureConnect Adapter)

Test Notes

1. All emissions lying in restricted bands specified in §15.205 are below the limit shown in Table 8-8.
2. The antenna is manipulated through typical positions, polarity and length during the tests.
3. This unit was tested while powered by a 12V DC power source (battery).
4. The spectrum is measured from 9kHz to the 10th harmonic of the fundamental frequency of the transmitter using CISPR quasi peak detector below 1GHz. Above 1 GHz, peak measurements were taken using linearly polarized horn antennas. The worst-case emissions are reported however emissions whose levels were not within 20dB of the respective limits were not reported.
5. Emissions below 18GHz were measured at a 3 meter test distance while emissions above 18GHz were measured at a 1 meter test distance with the application of a distance correction factor.
6. The wide spectrum spurious emissions plots shown on the following pages are used only for the purpose of emission identification. Any emissions found to be within 20dB of the limit are fully investigated and the results are shown in this section.

Sample Calculations

Determining Spurious Emissions Levels

- Field Strength Level $_{[dB_{\mu V/m}]}$ = Analyzer Level $_{[dBm]} + 107 + AFCL_{[dB/m]}$
- $AFCL_{[dB/m]} = Antenna\ Factor_{[dB/m]} + Cable\ Loss_{[dB]}$
- Margin $_{[dB]} = Field\ Strength\ Level_{[dB_{\mu V/m}]} - Limit_{[dB_{\mu V/m}]}$

FCC ID: RS2SXEZR2		MEASUREMENT REPORT (CERTIFICATION)	Approved by: Technical Manager
Test Report S/N: 1M2303100028-03.RS2	Test Dates: 3/20/2023 - 3/30/2023	EUT Type: Satellite Radio with FM transmitter	Page 31 of 43

Radiated Spurious Emission Measurements – Configuration #7 Onyx EZR and FEA unit

§15.239(c), §15.209, RSS-210(B.9(c))

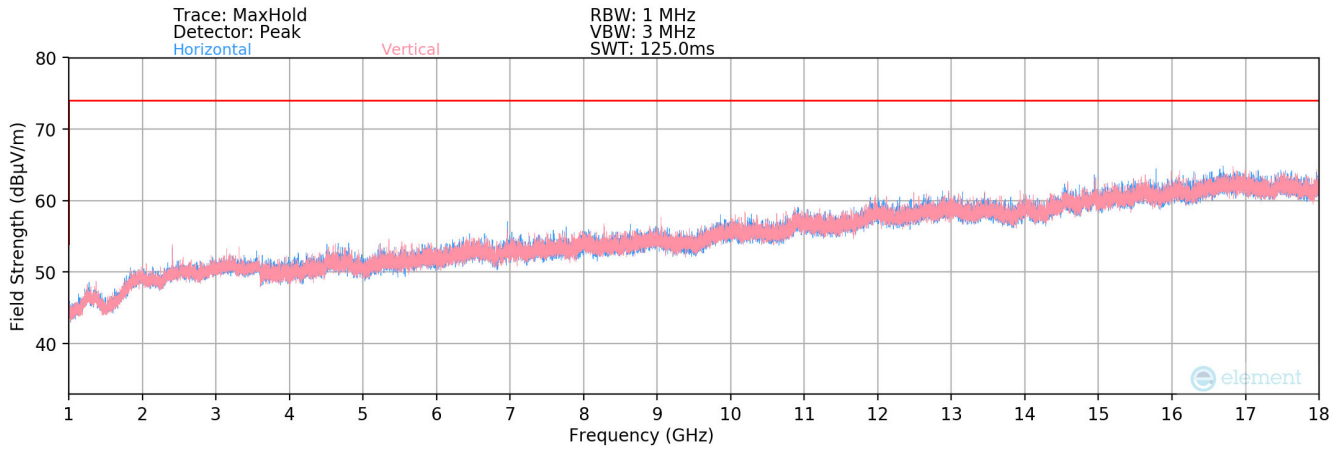

Plot 8-19. Radiated Spurious Plot above 1GHz (88.1MHz)

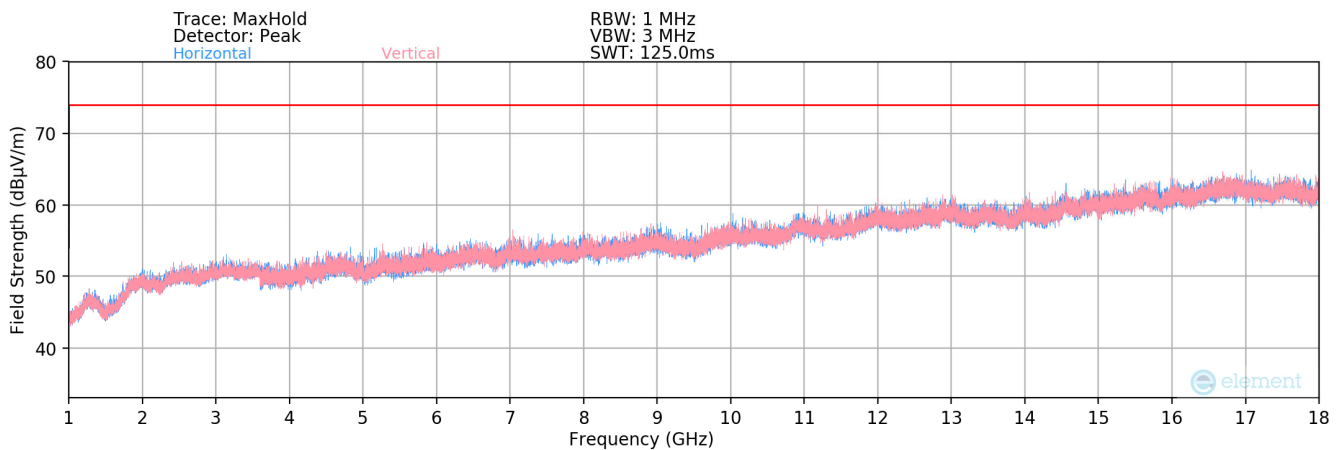

Plot 8-20. Radiated Spurious Plot above 1GHz (96.9MHz)

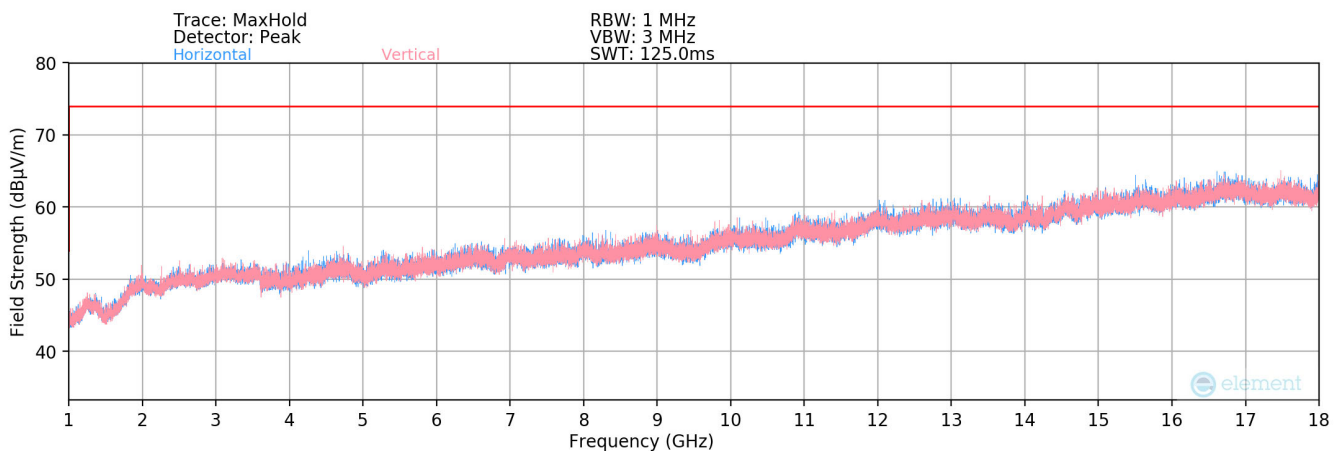

Plot 8-21. Radiated Spurious Plot above 1GHz (107.9MHz)

FCC ID: RS2SXEZR2			MEASUREMENT REPORT (CERTIFICATION)	Approved by: Technical Manager
Test Report S/N: 1M2303100028-03.RS2	Test Dates: 3/20/2023 - 3/30/2023	EUT Type: Satellite Radio with FM transmitter		Page 32 of 43

Radiated Spurious Emission Measurements

§15.239(c), §15.209, RSS-210(B.9(c))

Distance of Measurements: 3 Meters

Operating Frequencies: 88.1MHz

Frequency [MHz]	Detector	Ant. Pol. [H/V]	Analyzer Level [dBm]	AFCL [dB/m]	Field Strength [dBµV/m]	Limit [dBµV/m]	Margin [dB]
2410.43	Avg	V	-77.67	9.92	39.25	53.98	-14.73
2410.43	Peak	V	-63.06	9.92	53.86	73.98	-20.12
6989.34	Avg	H	-78.96	16.30	44.34	53.98	-9.64
6989.34	Peak	H	-65.55	16.30	57.75	73.98	-16.23

Table 8-10. Radiated Measurements above 1GHz, Configuration #7

Distance of Measurements: 3 Meters

Operating Frequencies: 96.9MHz

Frequency [MHz]	Detector	Ant. Pol. [H/V]	Analyzer Level [dBm]	AFCL [dB/m]	Field Strength [dBµV/m]	Limit [dBµV/m]	Margin [dB]
7012.64	Avg	V	-78.94	16.29	44.35	53.98	-9.63
7012.64	Peak	V	-65.45	16.29	57.84	73.98	-16.14
14552.31	Avg	H	-81.31	24.36	50.05	53.98	-3.93
14552.31	Peak	H	-67.80	24.36	63.56	73.98	-10.42

Table 8-11. Radiated Measurements above 1GHz, Configuration #7

FCC ID: RS2SXEZR2	 MEASUREMENT REPORT (CERTIFICATION)		Approved by: Technical Manager
Test Report S/N: 1M2303100028-03.RS2	Test Dates: 3/20/2023 - 3/30/2023	EUT Type: Satellite Radio with FM transmitter	Page 33 of 43

Distance of Measurements: 3 Meters
 Operating Frequencies: 107.9MHz

Frequency [MHz]	Detector	Ant. Pol. [H/V]	Analyzer Level [dBm]	AFCL [dB/m]	Field Strength [dB μ V/m]	Limit [dB μ V/m]	Margin [dB]
4701.23	Avg	V	-77.82	13.32	42.50	53.98	-11.48
4701.23	Peak	V	-64.98	13.32	55.34	73.98	-18.64
4235.61	Avg	H	-77.56	12.25	41.69	53.98	-12.29
4235.61	Peak	H	-65.35	12.25	53.90	73.98	-20.08

Table 8-12. Radiated Measurements above 1GHz, Configuration #7

FCC ID: RS2SXEZR2		MEASUREMENT REPORT (CERTIFICATION)	Approved by: Technical Manager
Test Report S/N: 1M2303100028-03.RS2	Test Dates: 3/20/2023 - 3/30/20/23	EUT Type: Satellite Radio with FM transmitter	Page 34 of 43

Radiated Spurious Emission Measurements – Configuration #8 Onyx EZR – PowerConnect only

§15.239(c), §15.209, RSS-210(B.9(c))

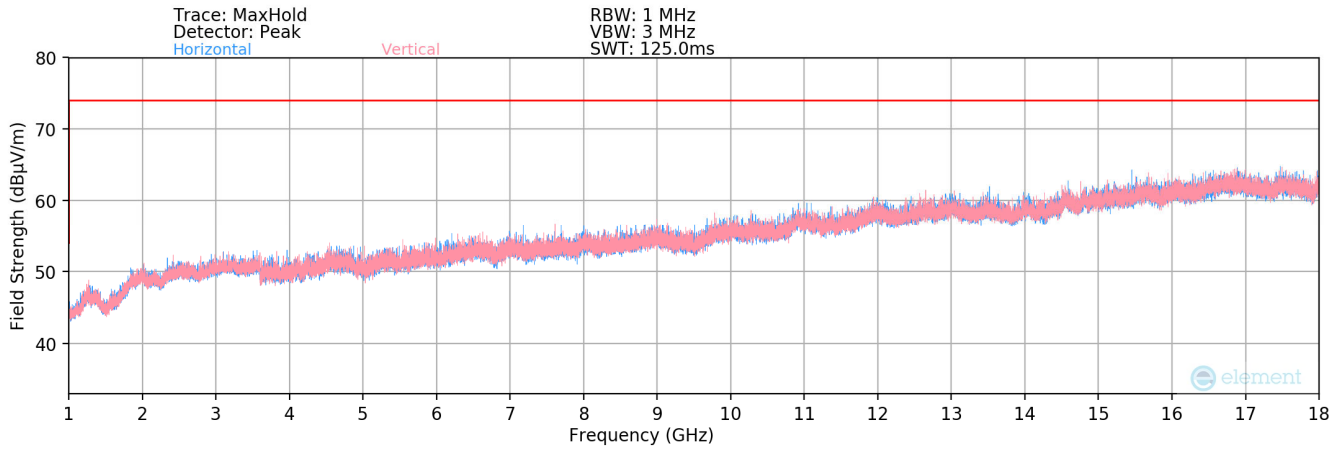

Plot 8-22. Radiated Spurious Plot above 1GHz (88.1)

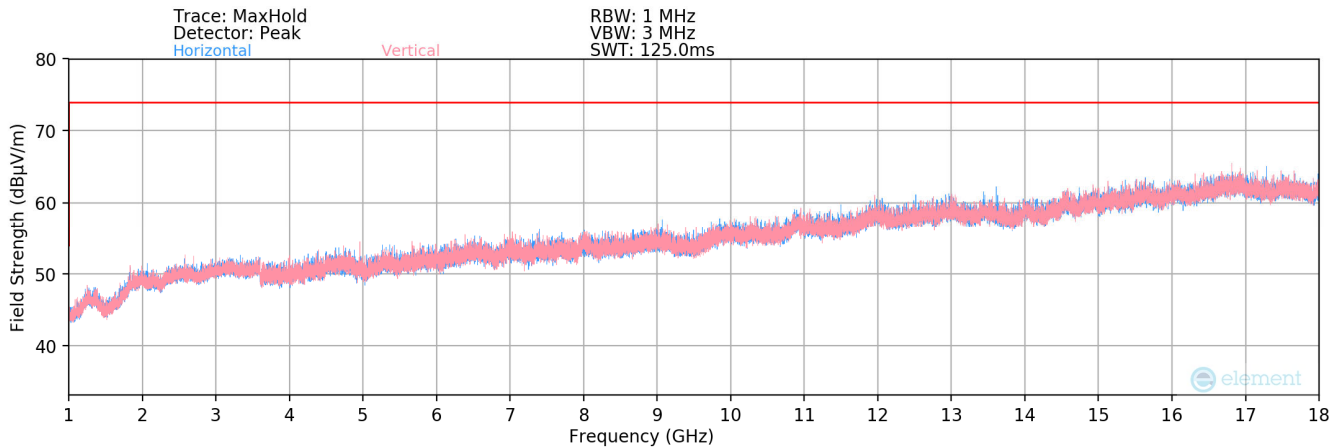

Plot 8-23. Radiated Spurious Plot above 1GHz (96.9)

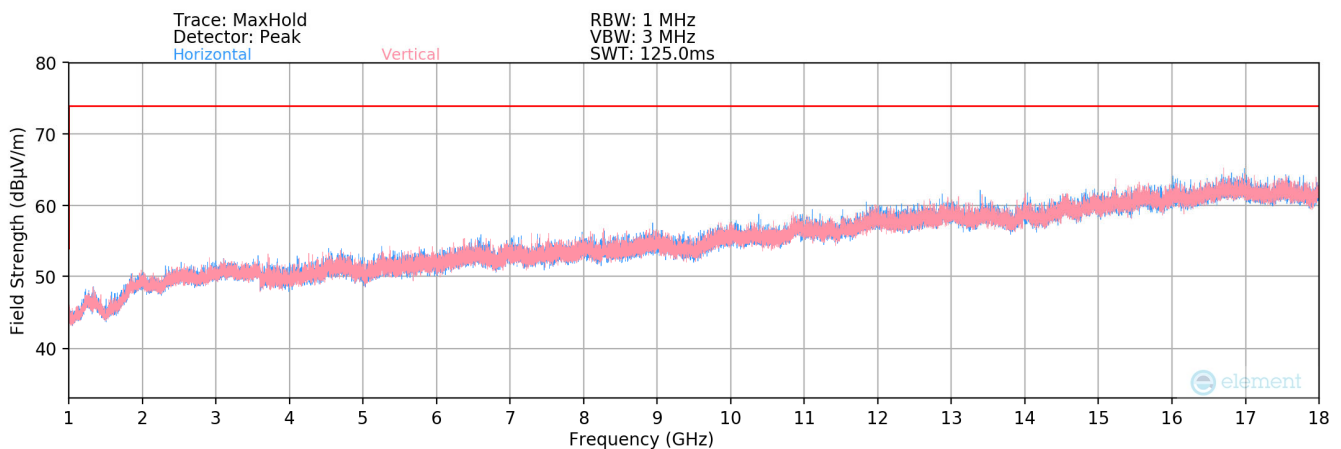

Plot 8-24. Radiated Spurious Plot above 1GHz (107.9)

FCC ID: RS2SXEZR2	 MEASUREMENT REPORT (CERTIFICATION)		Approved by: Technical Manager
Test Report S/N: 1M2303100028-03.RS2	Test Dates: 3/20/2023 - 3/30/20/23	EUT Type: Satellite Radio with FM transmitter	Page 35 of 43



Radiated Spurious Emission Measurements – Configuration #8
 §15.239(c), §15.209, RSS-210(B.9(c))

Distance of Measurements: 3 Meters
 Operating Frequencies: 88.1MHz

Frequency [MHz]	Detector	Ant. Pol. [H/V]	Analyzer Level [dBm]	AFCL [dB/m]	Field Strength [dBµV/m]	Limit [dBµV/m]	Margin [dB]
7652.34	Avg	V	-78.16	16.71	45.55	53.98	-8.43
7652.34	Avg	V	-66.91	16.71	56.80	73.98	-17.18
15429.10	Avg	H	-80.62	25.12	51.50	53.98	-2.47
15429.10	Peak	H	-68.19	25.12	63.93	73.98	-10.04

Table 8-13. Radiated Measurements above 1GHz, Configuration #8

Distance of Measurements: 3 Meters
 Operating Frequencies: 96.9MHz

Frequency [MHz]	Detector	Ant. Pol. [H/V]	Analyzer Level [dBm]	AFCL [dB/m]	Field Strength [dBµV/m]	Limit [dBµV/m]	Margin [dB]
11992.40	Avg	V	-80.25	22.53	49.28	53.98	-4.70
11992.40	Peak	V	-68.29	22.53	61.24	73.98	-12.74
13552.30	Avg	H	-81.23	23.24	49.01	53.98	-4.97
13552.30	Peak	H	-66.44	23.24	63.80	73.98	-10.18

Table 8-14. Radiated Measurements above 1GHz, Configuration #8

FCC ID: RS2SXEZR2			MEASUREMENT REPORT (CERTIFICATION)	Approved by: Technical Manager
Test Report S/N: 1M2303100028-03.RS2	Test Dates: 3/20/2023 - 3/30/2023	EUT Type: Satellite Radio with FM transmitter		Page 36 of 43

Distance of Measurements: 3 Meters
 Operating Frequencies: 107.9MHz

Frequency [MHz]	Detector	Ant. Pol. [H/V]	Analyzer Level [dBm]	AFCL [dB/m]	Field Strength [dB μ V/m]	Limit [dB μ V/m]	Margin [dB]
16561.10	Avg	V	-80.75	26.80	53.05	53.98	-0.92
16561.10	Peak	V	-69.09	26.80	64.71	73.98	-9.26
16881.96	Avg	H	-80.91	27.18	53.27	53.98	-0.71
16881.96	Peak	H	-69.36	27.18	64.82	73.98	-9.16

Table 8-15. Radiated Measurements above 1GHz, Configuration #8

FCC ID: RS2SXEZR2	 MEASUREMENT REPORT (CERTIFICATION)		Approved by: Technical Manager
Test Report S/N: 1M2303100028-03.RS2	Test Dates: 3/20/2023 - 3/30/2023	EUT Type: Satellite Radio with FM transmitter	Page 37 of 43

Radiated Spurious Emission Measurements – Configuration #9 Onyx EZR with Xpress Car Dock & SureConnect Adapter

§15.239(c), §15.209, RSS-210(B.9(c))

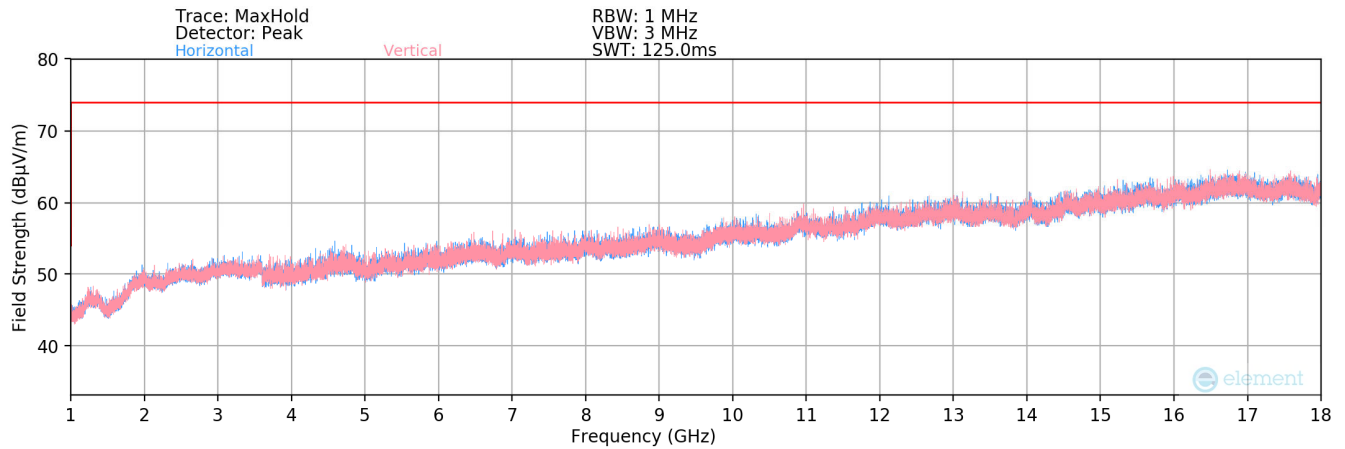

Plot 8-25. Radiated Spurious Plot above 1GHz (88.1)

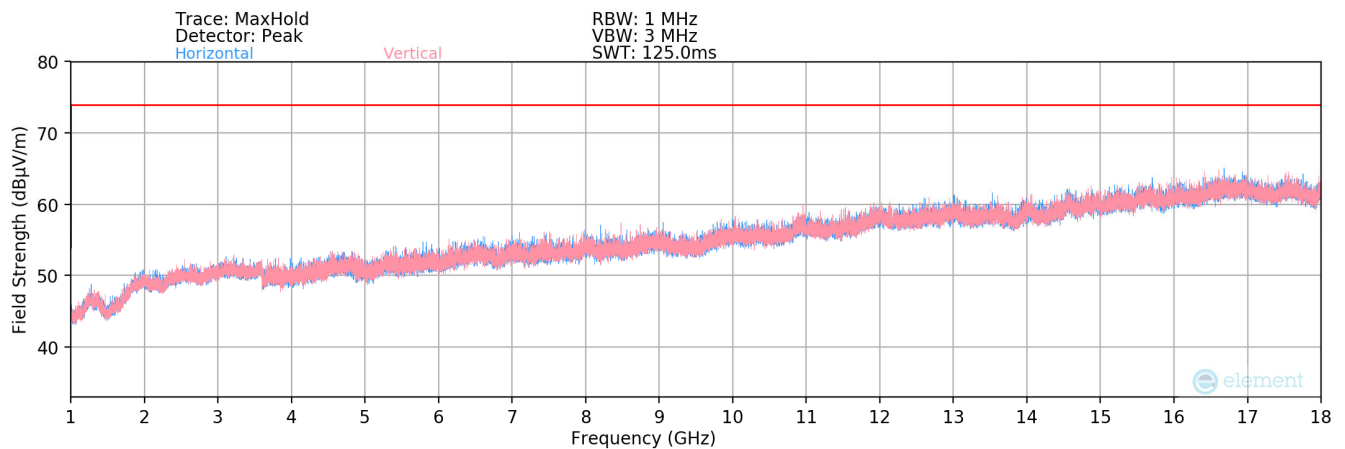

Plot 8-26. Radiated Spurious Plot above 1GHz (96.9)

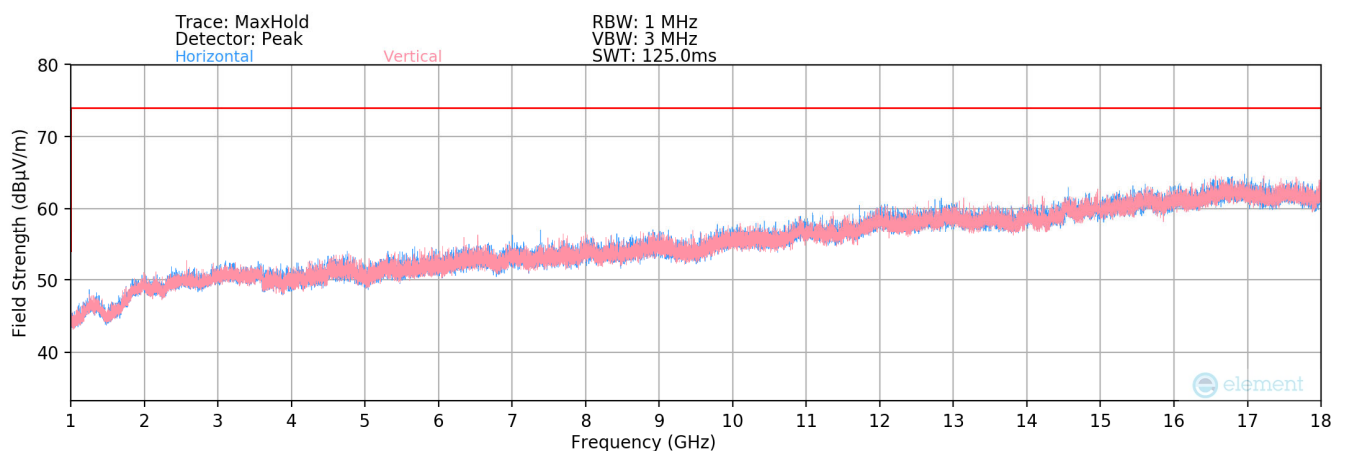

Plot 8-27. Radiated Spurious Plot above 1GHz (107.9)

FCC ID: RS2SXZR2	 MEASUREMENT REPORT (CERTIFICATION)		Approved by: Technical Manager
Test Report S/N: 1M2303100028-03.RS2	Test Dates: 3/20/2023 - 3/30/2023	EUT Type: Satellite Radio with FM transmitter	Page 38 of 43

Radiated Spurious Emission Measurements – Configuration #9

§15.239(c), §15.209, RSS-210(B.9(c))

Distance of Measurements: 3 Meters
 Operating Frequencies: 88.1MHz

Frequency [MHz]	Detector	Ant. Pol. [H/V]	Analyzer Level [dBm]	AFCL [dB/m]	Field Strength [dBµV/m]	Limit [dBµV/m]	Margin [dB]
16491.53	Avg	V	-80.83	26.71	52.88	53.98	-1.10
16491.53	Peak	V	-69.07	26.71	64.64	73.98	-9.34
1746.30	Avg	H	-76.92	6.87	36.95	53.98	-17.03
1746.30	Peak	H	-62.25	6.87	51.62	73.98	-22.36

Table 8-16. Radiated Measurements above 1GHz, Configuration #9

Distance of Measurements: 3 Meters
 Operating Frequencies: 96.9MHz

Frequency [MHz]	Detector	Ant. Pol. [H/V]	Analyzer Level [dBm]	AFCL [dB/m]	Field Strength [dBµV/m]	Limit [dBµV/m]	Margin [dB]
17520.03	Avg	V	-80.75	26.11	52.36	53.98	-1.62
17520.03	Peak	V	-68.61	26.11	64.50	73.98	-9.48
7102.43	Avg	H	-78.68	16.17	44.49	53.98	-9.49
7102.43	Peak	H	-67.17	16.17	56.00	73.98	-17.98

Table 8-17. Radiated Measurements above 1GHz, Configuration #9

FCC ID: RS2SXEZR2	 MEASUREMENT REPORT (CERTIFICATION)		Approved by: Technical Manager
Test Report S/N: 1M2303100028-03.RS2	Test Dates: 3/20/2023 - 3/30/2023	EUT Type: Satellite Radio with FM transmitter	Page 39 of 43

Distance of Measurements: 3 Meters
 Operating Frequencies: 107.9MHz

Frequency [MHz]	Detector	Ant. Pol. [H/V]	Analyzer Level [dBm]	AFCL [dB/m]	Field Strength [dB μ V/m]	Limit [dB μ V/m]	Margin [dB]
14206.16	Avg	V	-80.33	23.38	50.05	53.98	-3.93
14206.16	Peak	V	-68.71	23.38	61.67	73.98	-12.31
7388.60	Avg	H	-79.04	16.76	44.72	53.98	-9.26
7388.60	Peak	H	-66.75	16.76	57.01	73.98	-16.97

Table 8-18. Radiated Measurements above 1GHz, Configuration #9

FCC ID: RS2SXEZR2		MEASUREMENT REPORT (CERTIFICATION)	Approved by: Technical Manager
Test Report S/N: 1M2303100028-03.RS2	Test Dates: 3/20/2023 - 3/30/20/23	EUT Type: Satellite Radio with FM transmitter	Page 40 of 43

8.6 Frequency Stability / Temperature Variation

§2.1055

Test Overview and Limit

Frequency stability testing is performed in accordance with the guidelines of ANSI C63.10-2013 Section 6.8.2. The frequency stability of the transmitter is measured by:

- a.) **Temperature:** The temperature is varied from -30°C to +50°C in 10°C increments using an environmental chamber.
- b.) **Primary Supply Voltage:** Vary primary supply voltage from 85 to 115 percent of the nominal value for other than hand carried battery equipment.

The frequency stability of the transmitter shall be sufficient to ensure that the fundamental emission stays within the authorized frequency block.

Test Procedure Used

ANSI C63.26-2015

Test Settings

1. The carrier frequency of the transmitter is measured at room temperature (20°C to provide a reference).
2. Frequency measurements shall be made at the extremes of the specified temperature range and at intervals of not more than 10° centigrade through the range. A period of time sufficient to stabilize all of the components of the oscillator circuit at each temperature level shall be allowed prior to frequency measurement. The short term transient effects on the frequency of the transmitter due to keying (except for broadcast transmitters) and any heating element cycling normally occurring at each ambient temperature level also shall be shown. Only the portion or portions of the transmitter containing the frequency determining and stabilizing circuitry need be subjected to the temperature variation test.

Test Setup

The EUT was monitored via a dipole antenna connected to a spectrum analyzer with the EUT placed inside an environmental chamber.

Test Notes

The transmitted frequency dropped once the temperature reached +35.3°C.

FCC ID: RS2SXEZR2		MEASUREMENT REPORT (CERTIFICATION)	Approved by: Technical Manager
Test Report S/N: 1M2303100028-03.RS2	Test Dates: 3/20/2023 - 3/30/20/23	EUT Type: Satellite Radio with FM transmitter	Page 41 of 43

V 9.0 02/01/2019

Frequency Stability Measurements

VOLTAGE (%)	POWER (VDC)	TEMP (°C)	FREQUENCY (Hz)	Freq. Dev. (Hz)	Deviation (%)
100 %	12.00	+ 20 (Ref)	107,905,247	0	0.0000000
100 %		- 30	107,904,944	-303	-0.0002806
100 %		- 20	107,903,572	-1,675	-0.0015522
100 %		- 10	107,903,577	-1,670	-0.0015478
100 %		0	107,905,019	-229	-0.0002119
100 %		+ 10	107,903,881	-1,366	-0.0012662
100 %		+ 30	107,904,944	-303	-0.0002806
100 %		+ 40	107,896,377	-8,870	-0.0082200
100 %		+ 50	107,895,441	-9,807	-0.0090881
85 %		10.20	+ 20	107,905,347	100
115 %	13.80	+ 20	107,905,219	-28	-0.0000258

Table 8-19. Frequency Stability Data (107.9MHz)

Note:

Based on the results of the frequency stability test at the center channel the frequency deviation results measured are very small. As such it is determined that the channels at the band edge would remain in-band when the maximum measured frequency deviation noted during the frequency stability tests is applied. Therefore the device is determined to remain operating in band over the temperature and voltage range as tested.

FCC ID: RS2SXEZR2	 MEASUREMENT REPORT (CERTIFICATION)		Approved by: Technical Manager
Test Report S/N: 1M2303100028-03.RS2	Test Dates: 3/20/2023 - 3/30/20/23	EUT Type: Satellite Radio with FM transmitter	Page 42 of 43

9.0 CONCLUSION

The data collected relate only to the item(s) tested and show that the **Sirius XM Satellite Radio with FM transmitter FCC ID: RS2SXEZR2** is in compliance with Part 15C of the FCC Rules and RSS-210 of the Innovation, Science, and Economic Development Canada Rules.

FCC ID: RS2SXEZR2	 MEASUREMENT REPORT (CERTIFICATION)		Approved by: Technical Manager
Test Report S/N: 1M2303100028-03.RS2	Test Dates: 3/20/2023 - 3/30/20/23	EUT Type: Satellite Radio with FM transmitter	Page 43 of 43