



MET Labs

HEADQUARTERS: 914 WEST PATAPSCO AVENUE • BALTIMORE, MARYLAND 21230 • PHONE (410) 354-3300 • FAX (410) 354-3313

May 24, 2019

Sirius XM Satellite Radio
1500 Eckington Place NE
Washington, DC 20002

Dear Beejay Jolayemi,

Enclosed is the EMC Wireless test report for compliance testing of the Sirius XM Satellite Radio, Spot Repeater. The Sirius XM Satellite Radio Spot Repeater was tested to the requirements of the FCC Certification rules under Title 47 of the Code of Federal Regulations (CFR), Part 25 for Satellite Communications.

Thank you for using the services of MET Laboratories, Inc. If you have any questions regarding these results or if MET can be of further service to you, please feel free to contact me.

Sincerely yours,

MET LABORATORIES, INC.

Angela D. Kekovski
Documentation Department

Reference: (\\Sirius XM Satellite Radio\EMC102372-FCC25 Rev. 4)

Certificates and reports shall not be reproduced except in full, without the written permission of MET Laboratories, Inc.



Electromagnetic Compatibility Criteria Test Report

For the

**Sirius XM Satellite Radio
Name: Spot Repeater
Model No: SR-20W**

Tested under

**FCC Certification Rules
Title 47 of the CFR, Part 25 for Satellite Communications**

MET Report: EMC102372-FCC25 Rev. 4

May 24, 2019

Prepared For:

**Sirius XM Satellite Radio
1500 Eckington Place NE
Washington, DC 20002**

**Prepared By:
MET Laboratories, Inc.
914 W. Patapsco Ave.
Baltimore, MD 21230**

Electromagnetic Compatibility Criteria Test Report

For the

Sirius XM Satellite Radio
Name: Spot Repeater
Model No: SR-20W

FCC Certification Rules
Title 47 of the CFR, Part 25 for Satellite Communications



Donald Salguero
Electromagnetic Compatibility Lab

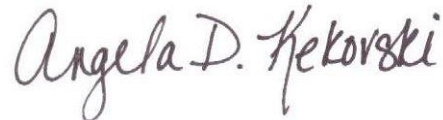

Angela D. Kekovski
Documentation Department

Engineering Statement: The measurements shown in this report were made in accordance with the procedures indicated, and the emissions from this equipment were found to be within the limits applicable. I assume full responsibility for the accuracy and completeness of these measurements, and for the qualifications of all persons taking them. It is further stated that upon the basis of the measurements made, the equipment tested is capable of operation in accordance with the requirements of Title 47 of the CFR, Part 25 of the FCC Rules under normal use and maintenance.



Benjamin Taylor
Electromagnetic Compatibility Lab

Report Status Sheet

Revision	Report Date	Reason for Revision
Ø	May 3, 2019	Initial Issue.
1	May 7, 2019	Edits to EUT references and clarification to Center Frequencies.
2	May 8, 2019	Correction to references for test setup photographs.
3	May 8, 2019	Changes to Frequency Stability
4	May 24, 2019	Customer requested corrections

Table of Contents

1. Executive Summary	1
1.1. Purpose of Test	2
1.2. Requirements Summary	2
2. Equipment Configuration.....	3
2.1. Overview	4
2.2. References.....	5
2.3. Test Site	5
2.4. Description of Test Sample.....	5
2.5. Equipment Configuration.....	6
2.6. Support Equipment	8
2.7. Ports and Cabling Information.....	8
2.8. Mode of Operation.....	8
2.9. Monitoring Method.....	9
2.10. Modifications.....	9
2.10.1. Modifications to EUT.....	9
2.10.2. Modifications to Test Standard.....	9
2.11. Disposition of EUT.....	9
3. Electromagnetic Compatibility Criteria for Intentional Radiators.....	10
3.1. §25.214(d)(1) RF Output Power	11
3.2. §25.144(e)(7)(ii), §25.214(d)(1) Peak to Average Ratio.....	13
3.3. §25.202(h)(1) Spurious at Antennas	15
3.4. §2.1049 Occupied Bandwidth.....	20
3.5. §25.202(d) Frequency Stability.....	22
3.6. §2.1053 Cabinet Spurious Radiation.....	24
4. Test Equipment	27
5. Certification Label & User’s Manual Information	29
5.1. Certification Information	30
5.2. Label and User’s Manual Information	34

List of Tables

Table 1. Requirements Summary of EMC Part 25 Compliance Testing	2
Table 2. EUT Summary Table	4
Table 3. Standard References	5
Table 4. Equipment Configuration	6
Table 5. Support Equipment	8
Table 6. Ports and Cabling Information	8
Table 7. Peak to Average Ratio, Test Results	13
Table 8. Occupied Bandwidth, Test Results	20
Table 9. Frequency Stability, Test Results, Low Band	22
Table 10. Frequency Stability, Test Results, High Band	23

List of Plots

Plot 1. Radiated RF Output Power, Dual Channel	11
Plot 2. Radiated RF Output Power, High Band Channel	12
Plot 3. Radiated RF Output Power, Low Band Channel	12
Plot 4. Peak to Average Ratio, High Band Channel	14
Plot 5. Peak to Average Ratio, Low Band Channel	14
Plot 6. Conducted Spurious Emissions, 30-1000 MHz	16
Plot 7. Conducted Spurious Emissions, 1-6 GHz	16
Plot 8. Conducted Spurious Emissions, 1-6 GHz (2 nd harmonic)	17
Plot 9. Conducted Spurious Emissions, 6-12 GHz	18
Plot 10. Conducted Spurious Emissions, 12-18 GHz	18
Plot 11. Conducted Spurious Emissions, 18-24 GHz	19
Plot 12. 99% Occupied Bandwidth, Test Results, Low Band Channel	21
Plot 13. 99% Occupied Bandwidth, Test Results, High Band Channel	21
Plot 14. Cabinet Spurious Radiation, Tx Off, 30 MHz – 1 GHz	25
Plot 15. Cabinet Spurious Radiation, Tx On, 30 MHz – 1 GHz	25
Plot 16. Cabinet Spurious Radiation, 1 GHz – 6 GHz	26
Plot 17. Cabinet Spurious Radiation, 1 GHz – 6 GHz, 1.28 GHz spur	26

List of Terms and Abbreviations

AC	Alternating Current
ACF	Antenna Correction Factor
Cal	Calibration
<i>d</i>	Measurement Distance
dB	Decibels
dBμA	Decibels above one microamp
dBμV	Decibels above one microvolt
dBμA/m	Decibels above one microamp per meter
dBμV/m	Decibels above one microvolt per meter
DC	Direct Current
E	Electric Field
DSL	Digital Subscriber Line
ESD	Electrostatic Discharge
EUT	Equipment Under Test
<i>f</i>	Frequency
FCC	Federal Communications Commission
GRP	Ground Reference Plane
H	Magnetic Field
HCP	Horizontal Coupling Plane
Hz	Hertz
IEC	International Electrotechnical Commission
kHz	kilohertz
kPa	kilopascal
kV	kilovolt
LISN	Line Impedance Stabilization Network
MHz	Megahertz
μH	microhenry
μ	microfarad
μs	microseconds
NEBS	Network Equipment-Building System
PRF	Pulse Repetition Frequency
RF	Radio Frequency
RMS	Root-Mean-Square
TWT	Traveling Wave Tube
V/m	Volts per meter
VCP	Vertical Coupling Plane

I. Executive Summary

A. Purpose of Test

An EMC evaluation to determine compliance of the Sirius XM Satellite Radio model Spot Repeater with the requirements of Part 25 was performed. All references are to the most current version of Title 47 of the Code of Federal Regulations in effect. In accordance with §2.1033, the following data is presented in support of the Certification of the Sirius XM Satellite Radio model Spot Repeater. Sirius XM Satellite Radio should retain a copy of this document which should be kept on file for at least two years after the manufacturing of the Spot Repeater has been **permanently** discontinued.

B. Requirements Summary

The following tests were conducted on a sample of the equipment for the purpose of demonstrating compliance with Part 25, in accordance with Sirius XM Satellite Radio, quote number 316758. All tests were conducted using measurement procedure EIA/TIA-603.

FCC Reference	Description	Compliance
§25.144(e)(7)(ii), §25.214(d)(1)	Peak to Average Ratio	Compliant
§25.202(h)(1)	Spurious at Antennas	Compliant
§25.214(d)(1)	Radiated RF Output Power	Compliant
§25.202(f)	Occupied Bandwidth	Compliant
§25.202(d)	Temperature/Voltage Stability	Compliant
§2.1053	Cabinet Spurious Radiation	Compliant

Table 1. Requirements Summary of EMC Part 25 Compliance Testing

II. Equipment Configuration

A. Overview

MET Laboratories, Inc. was contracted by Sirius XM Satellite Radio to perform testing on the Spot Repeater, under Sirius XM Satellite Radio’s PO number 328610.

This document describes the test setups, test methods, required test equipment, and the test limit criteria used to perform compliance testing of the Sirius XM Satellite Radio, Spot Repeater.

The results obtained relate only to the item(s) tested.

Model(s) Tested:	SR-20W	
Model(s) Covered:	Spot Repeater	
EUT Specifications:	Primary Power: 120 VAC	
	FCC ID: RS2SR20W	
	Type of Modulations:	COFDM
	EUT Frequency Ranges:	2320 – 2345 MHz
Analysis:	The results obtained relate only to the item(s) tested.	
Environmental Test Conditions:	Temperature: 15-35° C	
	Relative Humidity: 30-60%	
	Barometric Pressure: 860-1060 mbar	
Evaluated by:	Donald Salguero	
Date(s):	May 3, 2019	

Table 2. EUT Summary Table

B. References

CFR 47, Part 25	Federal Communication Commission, Code of Federal Regulations, Title 47, Part 25: Satellite Communications
ANSI C63.4:2014	Methods and Measurements of Radio-Noise Emissions from Low-Voltage Electrical And Electronic Equipment in the Range of 9 kHz to 40 GHz
ISO/IEC 17025:2005	General Requirements for the Competence of Testing and Calibration Laboratories
KDB 971168 D01 v03r01	Measurement Guidance for Certification of Licensed Digital Transmitters
ANSI C63.26:2015	American National Standard for Compliance Testing of Transmitters Used in Licensed Radio Services.

Table 3. Standard References

C. Test Site

All testing was performed at MET Laboratories, Inc., 914 W. Patapsco Ave., Baltimore, MD 21230. All equipment used in making physical determinations is accurate and bears recent traceability to the National Institute of Standards and Technology.

Radiated Emissions measurements were performed in semi-anechoic chamber. In accordance with §2.948(a)(3), a complete site description is contained at MET Laboratories.

D. Description of Test Sample

The Spot Repeater is a rack mounted signal repeater device for stellite programming transmission. The repeater repeats our satellite coverage in densely building populated citics/terrains. The Sirius XM 20W Spot repeater ingests proprietary High Band and Low Band Ethernet based UDP streams via an Ethernet based router. The router provides signal path routing to the Low Band UDP Exciter LUE and High Band UDP exciter HUE.

The LUE/HUE removes the UDP transport packaging and converts the data into a UDP based High Band and Low Band Terrestrial COFDM waveform. The two COFDM waveforms are GPS time synchronized and launched in exact time with the Satellite based DRU Terrestrial COFDM waveforms.

E. Equipment Configuration

Slot #	Name / Description	Model Nmber	Part Number
	Spot Repeater	SR-20W	SR-50-AC-20W

Table 4. Equipment Configuration

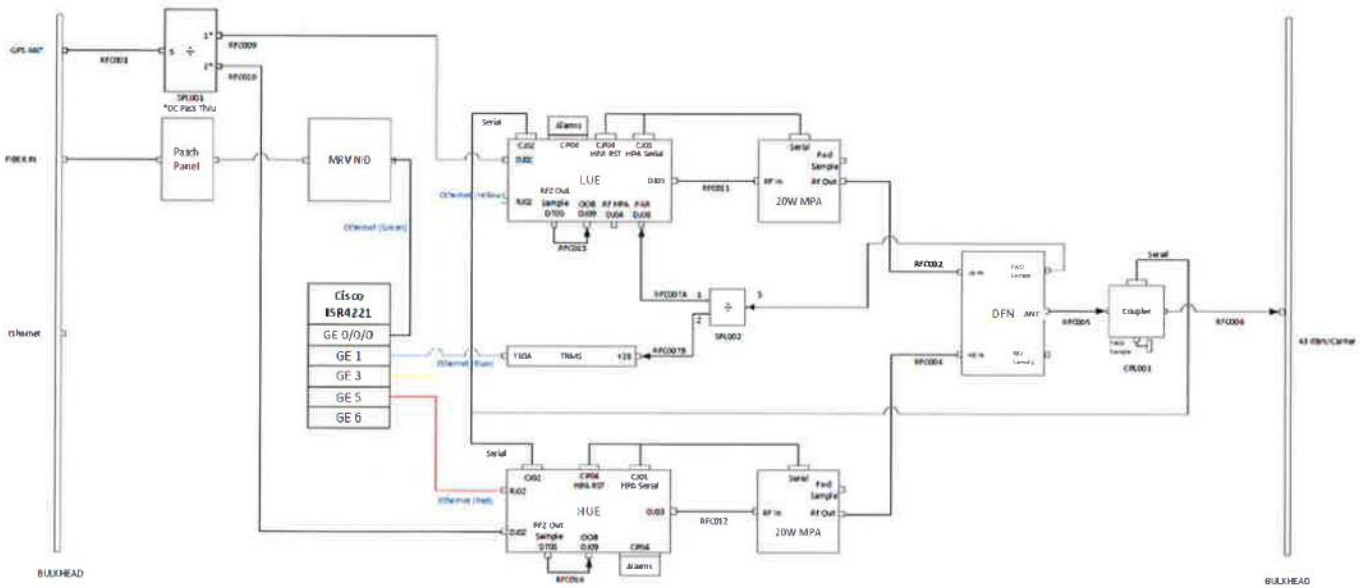

Figure 1. Block Diagram of Test Configuration – Signal Flow

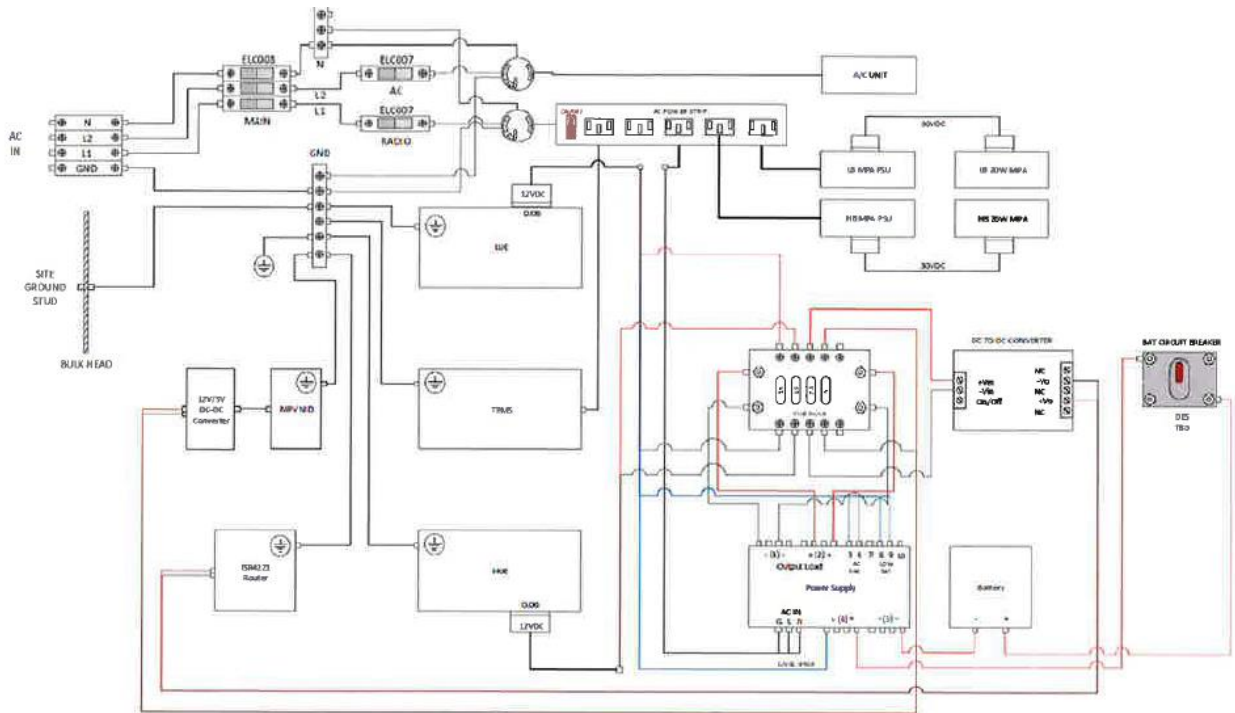

Figure 2. Block Diagram of Test Configuration – AC/DC/GND

F. Support Equipment

Name / Description	Manufacturer
LUE	IZT
HUE	IZT
Cisco Router	Cisco
Opti Switch MRV NID 05606	MRV
DFN	CCI
Coupler	CCI
TRMS	UBS
MPA	CCI

Table 5. Support Equipment

G. Ports and Cabling Information

Ref. ID	Port name on EUT	Cable Description or reason for no cable	Qty	Length as tested (m)	Max Length (m)	Shielded? (Y/N)	Termination Box ID & Port Name
1	GPS	RG59 Coax	1	30	60	Yes	GPS Input
2	AC Input	3 conductor, 18 awg	1	2	3	Yes	(208-240v/50hz)

Table 6. Ports and Cabling Information

H. Mode of Operation

The EUT operates normally when powered on and put in the TX mode.

I. Monitoring Method

1. A solid green “Data” LED will indicate error-free data is being transferred on the test cable.
2. Any other LED status besides the solid green LED (i.e. Blinking green LED, red LED, etc.) will indicate error-free data not being transferred on the test cable.

J. Modifications**a) Modifications to EUT**

No modifications were made to the EUT.

b) Modifications to Test Standard

No modifications were made to the Test Standard.

K. Disposition of EUT

The test sample including all support equipment submitted to the Electro-Magnetic Compatibility Lab for testing was returned to Sirius XM Satellite Radio upon completion of testing.

III. Electromagnetic Compatibility Criteria for Intentional Radiators

Electromagnetic Compatibility Criteria for Satellite Communications

§25.214(d)(1) RF Output Power

Test Requirement(s): §25.214(d)(1): *Power limit for SDARS terrestrial repeaters.* (1) SDARS terrestrial repeaters must be operated at a power level less than or equal to 12-kW average EIRP, with a maximum peak-to-average power ratio of 13 dB.

Test Procedures: The EUT was connected directly to a spectrum analyzer using appropriate attenuation. Settings for the spectrum analyzer were followed using the guidance provided in FCC KDB 971168 D01, section 5.2.2 which references subclause 5.2.4.4.1 of ANSI C63.26-2015. An RMS Power averaging detector was selected and the trace was averaged over at least 100 traces. The RF Output Power was recorded.

Test Results: The EUT is compliant with the requirements of this section.

Test Engineer(s): Donald Salguero

Test Date(s): 4/3/19

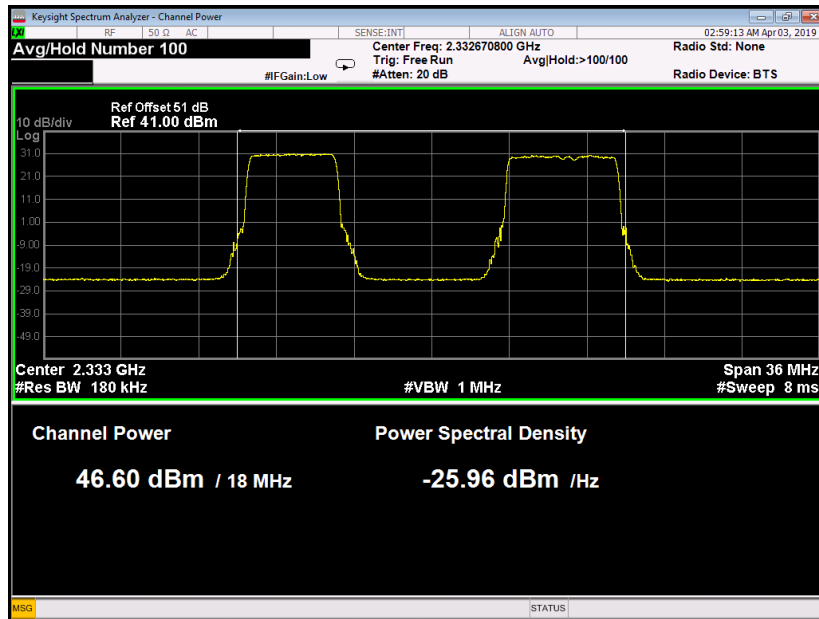

Plot 1. Radiated RF Output Power, Dual Channel

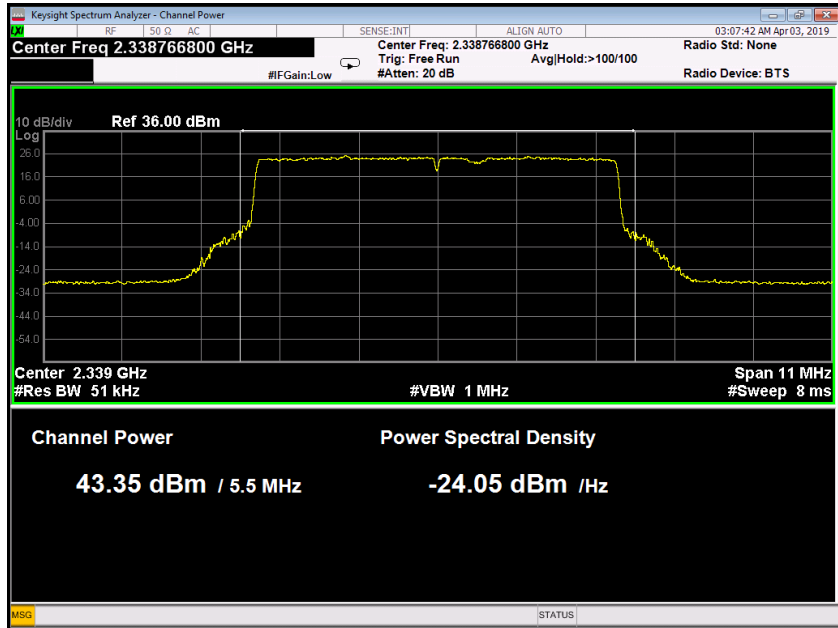

Plot 2. Radiated RF Output Power, High Band Channel

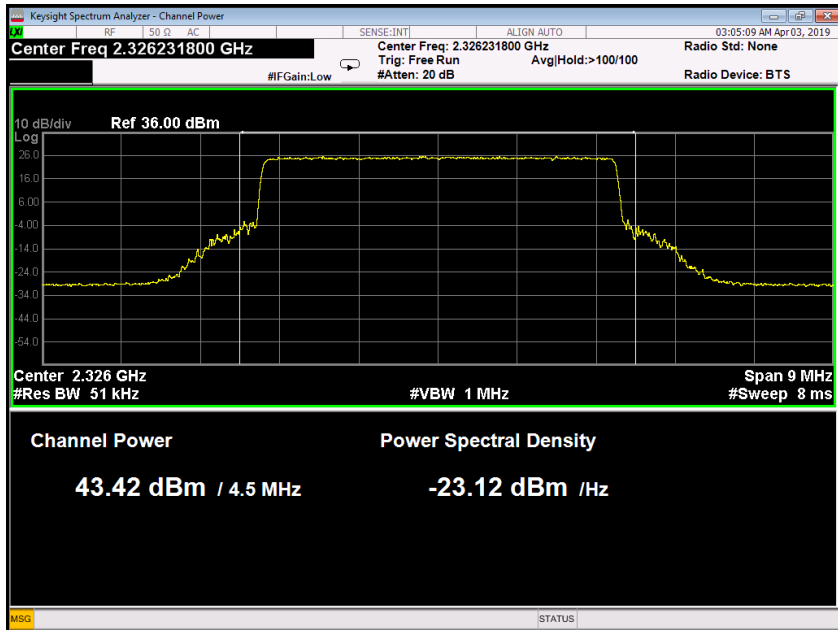

Plot 3. Radiated RF Output Power, Low Band Channel

Electromagnetic Compatibility Criteria for Satellite Communications

§25.144(e)(7)(ii), §25.214(d)(1) Peak to Average Ratio

Test Requirement(s): §25.144(e)(7)(ii): In addition to the procedures set forth in subpart J of part 2 of this chapter, power measurements for SDARS repeater transmitters may be made in accordance with a Commission-approved average power technique. Peak-to-average power ratio (PAPR) measurements for SDARS repeater transmitters should be made using either an instrument with complementary cumulative distribution function (CCDF) capabilities to determine that the PAPR will not exceed 13 dB for more than 0.1 percent of the time or another Commission approved procedure. The measurement must be performed using a signal corresponding to the highest PAPR expected during periods of continuous transmission.

§25.214(d)(1): *Power limit for SDARS terrestrial repeaters.* (1) SDARS terrestrial repeaters must be operated at a power level less than or equal to 12-kW average EIRP, with a maximum peak-to-average power ratio of 13 dB.

Test Procedures: The EUT was connected to a spectrum analyzer using appropriate attenuation and the CCDF measurement function was used to measure the Peak to Average Power Ratio. Settings for the spectrum analyzer were set to the parameters provided in FCC KDB 971168 D01. The measurement bandwidth was set to a value greater than the 99% Bandwidth. The measurement interval used was 1 ms. The maximum PAPR level associated with a probability of 0.1% was compared to the limit.

Test Results: The EUT is compliant with the requirements of this section.

Test Engineer(s): Donald Salguero

Test Date(s): 4/3/19

Center Frequency (MHz)	Average Power (dBm)	PAPR at 0.1% (dB)	Peak Power (dBm)
2326.25	43.42	8.53	51.95
2338.755	43.35	8.6	51.95

Table 7. Peak to Average Ratio, Test Results

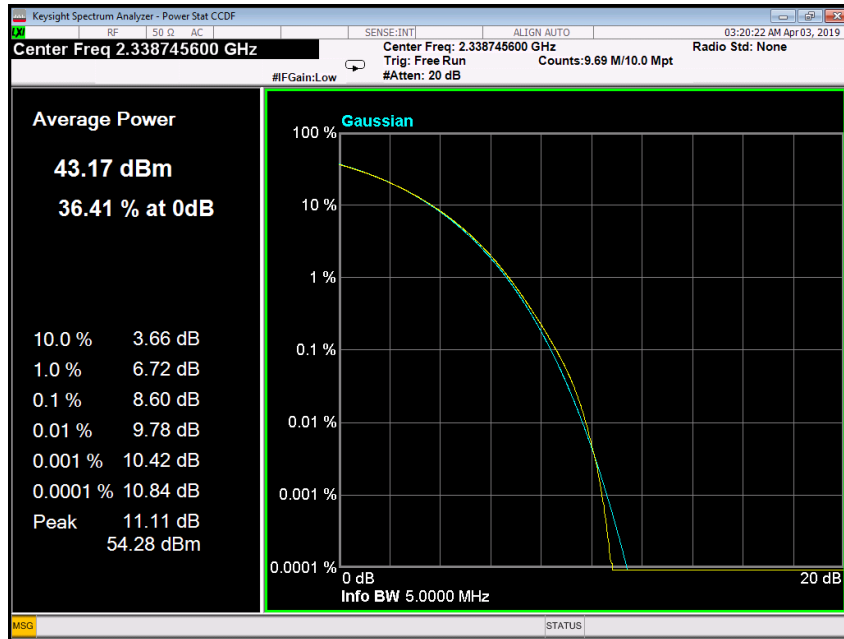

Plot 4. Peak to Average Ratio, High Band Channel

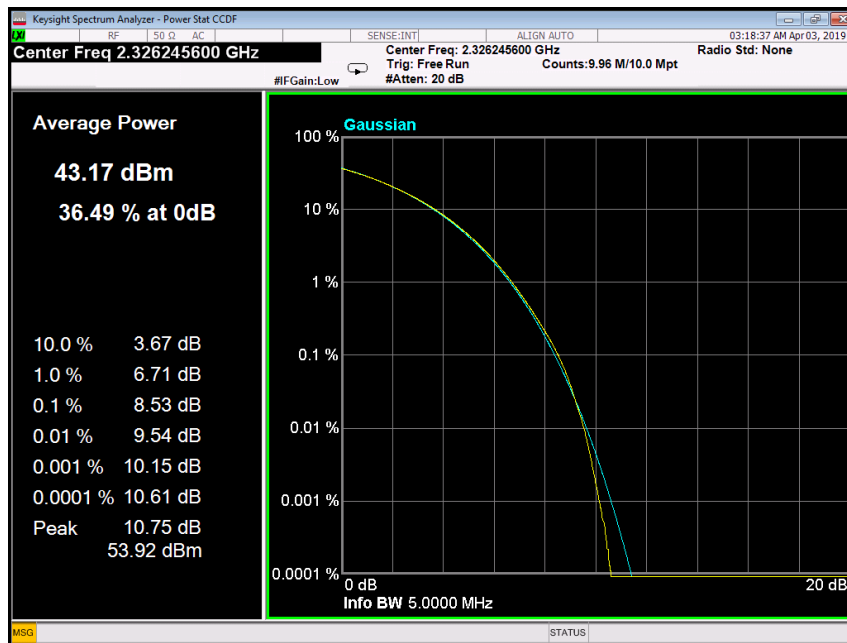

Plot 5. Peak to Average Ratio, Low Band Channel

Electromagnetic Compatibility Criteria for Satellite Communications

§25.202(h)(1) Spurious at Antennas

Test Requirement(s): §25.202(h): *Out-of-band emission limitations for SDARS terrestrial repeaters.* (1) Any SDARS terrestrial repeater operating at a power level greater than 2-watt average EIRP is required to attenuate its out-of-band emissions below the transmitter power P by a factor of not less than $90 + 10 \log (P)$ dB in a 1-megahertz bandwidth outside the 2320-2345 MHz band, where P is average transmitter output power in watts.

Test Procedures: The EUT was connected to a spectrum analyzer using appropriate attenuation and a tuned band reject filter centered at the transmit frequency. Care was taken to ensure that the appropriate adjustments for cable and reject filter losses were used for each measurement range.

For below 1 GHz measurements, cables losses and band reject attenuation were loaded into the spectrum analyzers corrections option. An external attenuator of 10 dB was added to the front end of the analyzer.

For above 1 GHz measurements, an external attenuator of 10 dB was added to the front end of the spectrum analyzer. The cable losses, band reject were swept, together for corrections, and loaded into the analyzers corrections option.

The correct limit is based on $90+10\log(P)$ dB; -60 dBm.

Test Results: The EUT is compliant with the requirements of this section.

Test Engineer(s): Donald Salguero

Test Date(s): 4/3/19

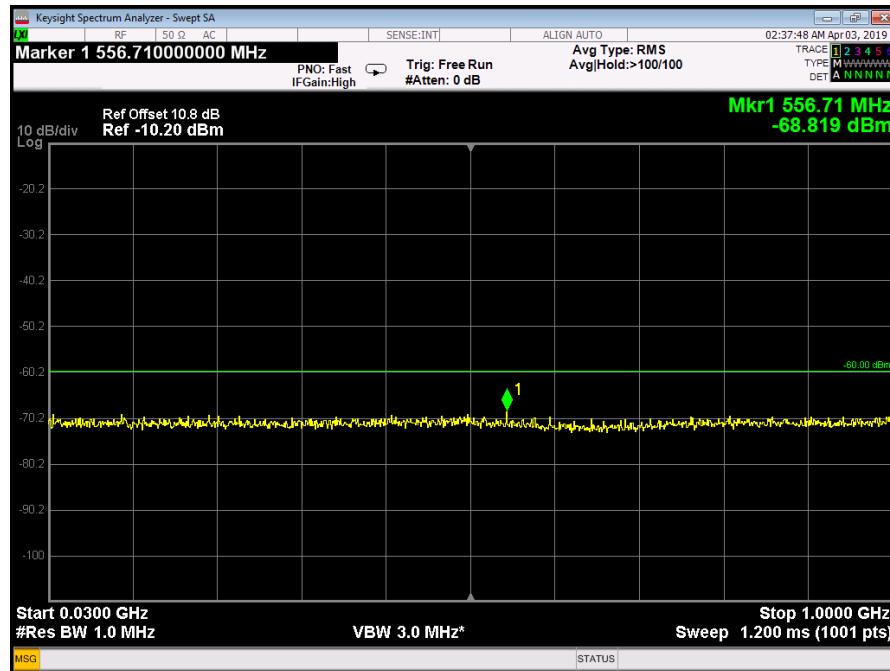

Plot 6. Conducted Spurious Emissions, 30-1000 MHz

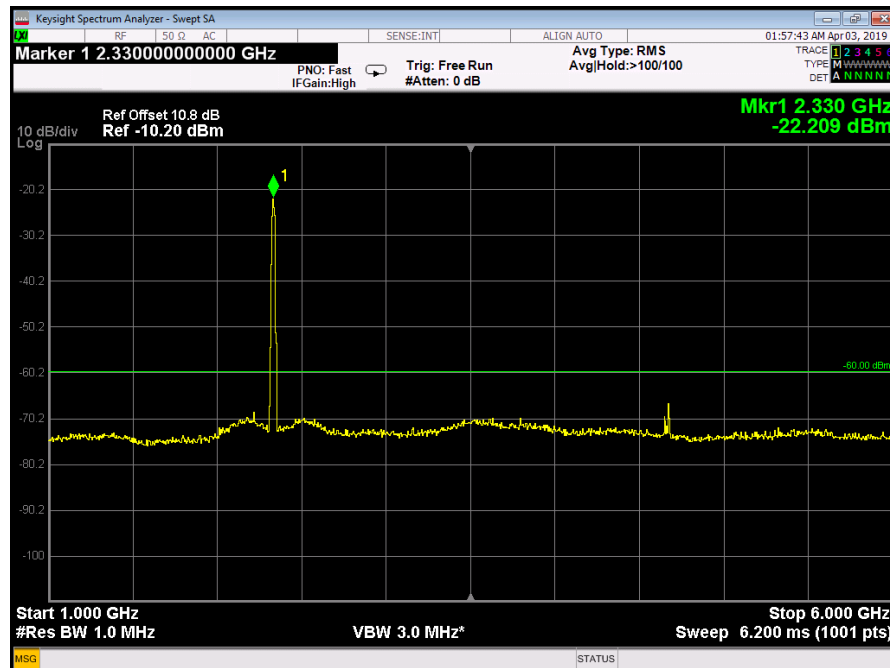

Plot 7. Conducted Spurious Emissions, 1-6 GHz

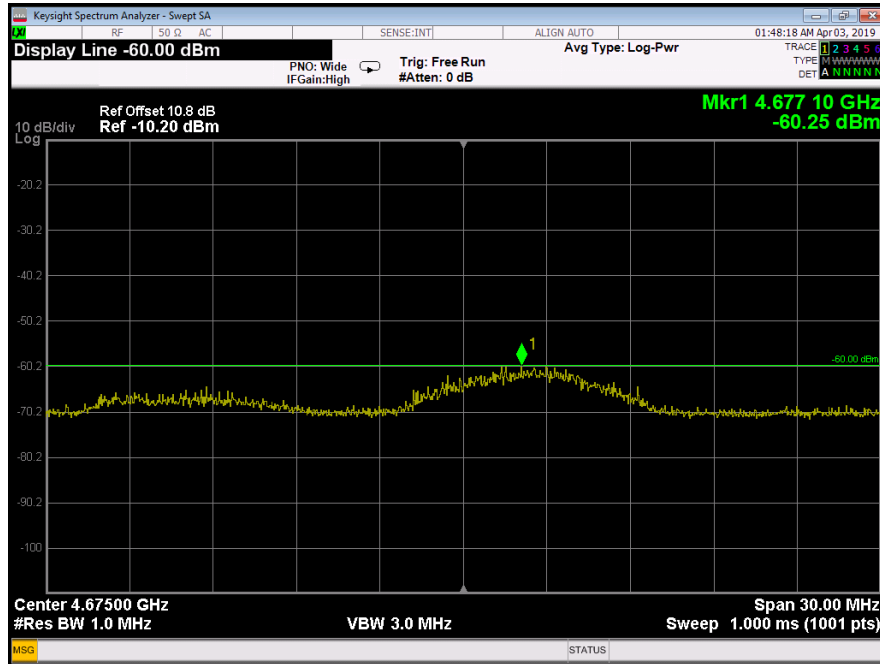

Plot 8. Conducted Spurious Emissions, 1-6 GHz (2nd harmonic)

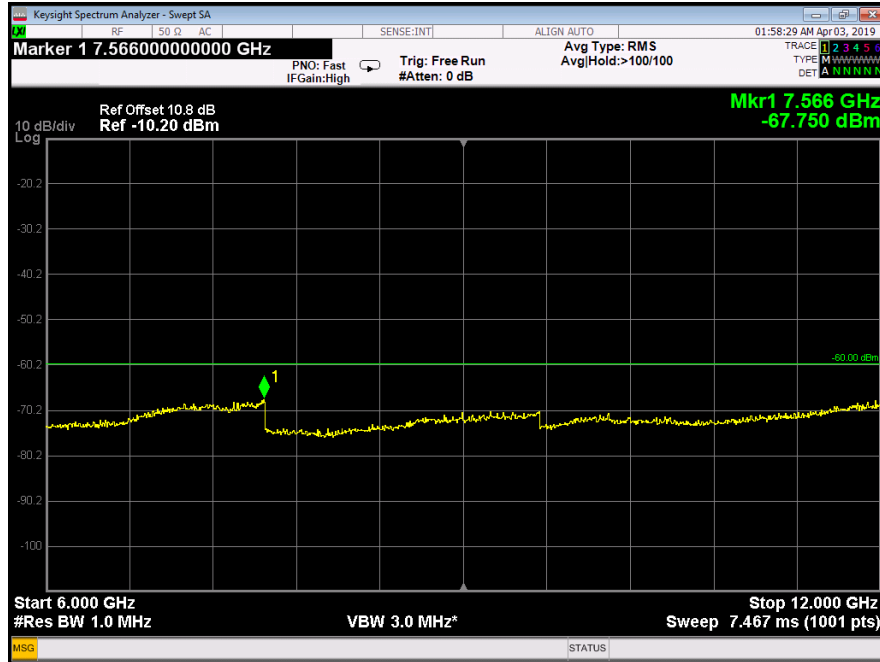

Plot 9. Conducted Spurious Emissions, 6-12 GHz

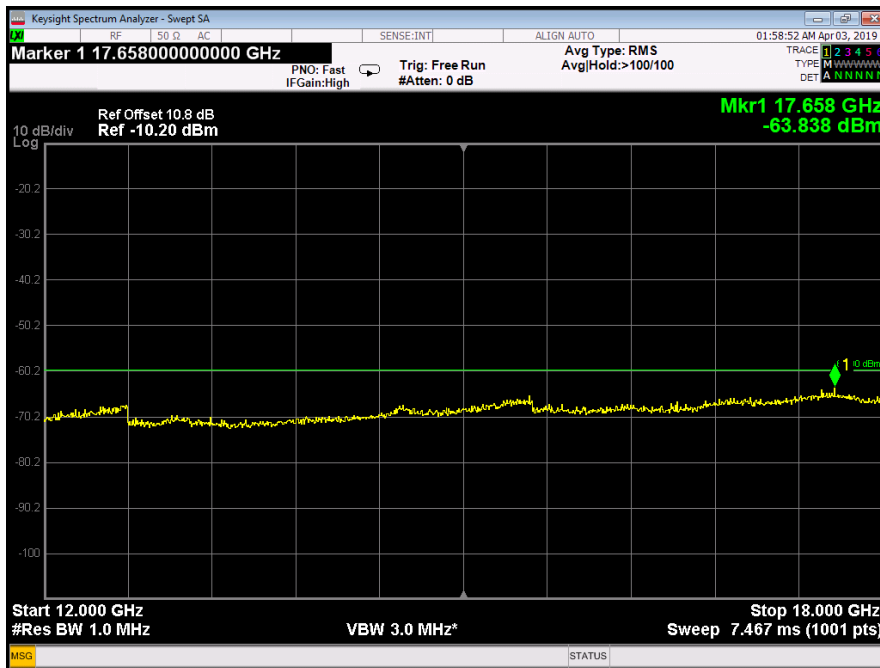

Plot 10. Conducted Spurious Emissions, 12-18 GHz

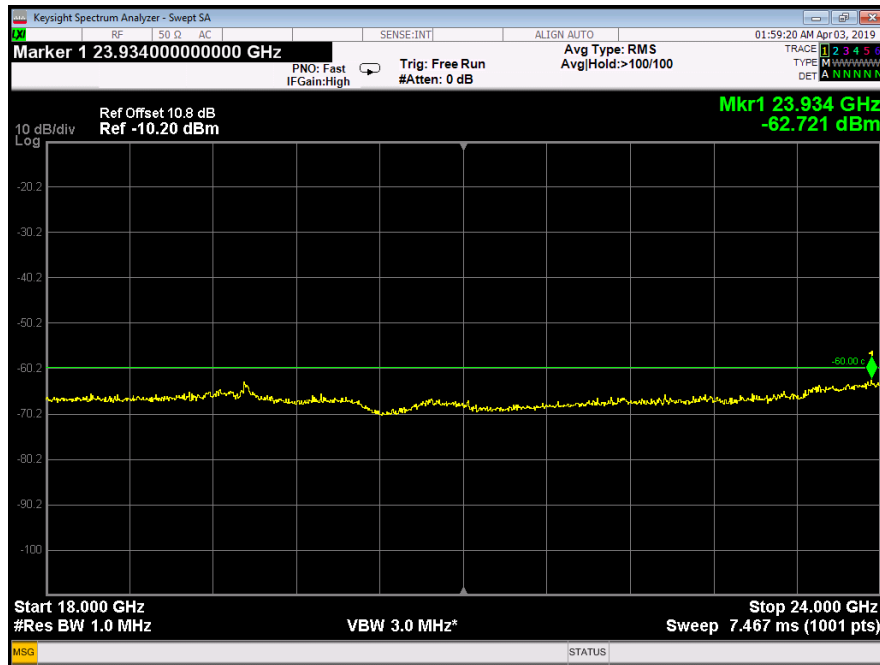

Plot 11. Conducted Spurious Emissions, 18-24 GHz

Electromagnetic Compatibility Criteria for Satellite Communications

§2.1049 Occupied Bandwidth

Test Requirement(s): §2.1049

Test Procedures: As required by 47 CFR 2.1049, *occupied bandwidth measurements* were made at the RF output terminals using a Spectrum Analyzer.

A laptop was connected to EUT to control the RF power output and frequency channel. The EUT was connected to a Spectrum Analyzer via attenuator. The measured highest Average Power was set relative to zero dB reference. The RBW of the Spectrum Analyzer was set to at least 1% of the channel bandwidth. The EUT power was adjusted at the maximum output power level.

Note: Out of Band Edge Emissions were investigated visually and deemed to be compliant under the $(90 + 10 \text{ Log}(P))/1$ MHz guideline, but raw data wasn't recorded. SiriusXM has conducted this test in a thoroughly manner and provided the data to the TCB for review.

Test Results: The EUT is compliant with the requirements of this section.

Test Engineer(s): Donald Salguero

Test Date(s): 4/3/19

Center Frequency (MHz)	99% Occupied Bandwidth (MHz)
2326.25	3.989
2338.755	4.9706

Table 8. Occupied Bandwidth, Test Results

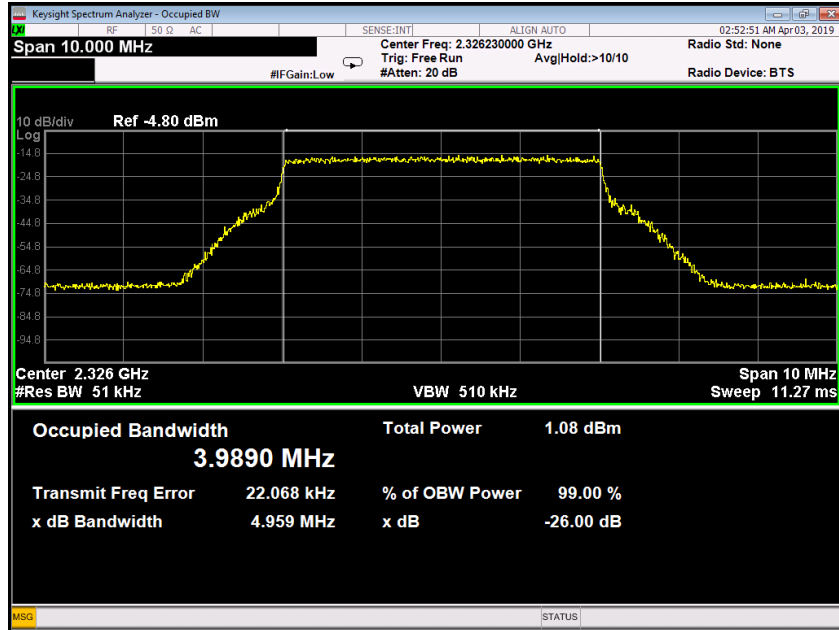

Plot 12. 99% Occupied Bandwidth, Test Results, Low Band Channel

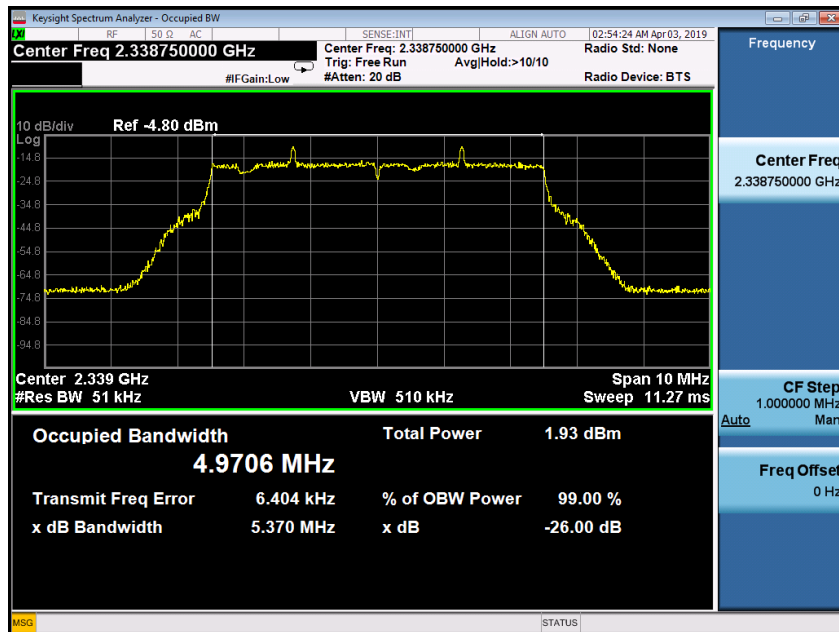

Plot 13. 99% Occupied Bandwidth, Test Results, High Band Channel

Electromagnetic Compatibility Criteria for Satellite Communications

§25.202(d) Frequency Stability

Test Requirement(s): §25.202(d) **Frequency Tolerance, Earth Stations** – The carrier frequency of each earth station transmitter authorized in these services shall be maintained within 0.001 percent of the reference frequency.

Test Procedures: The resolution bandwidth of the spectrum analyzer was set to 1 kHz and the trace was set to max hold. The EUT was set to transmit at max power. At nominal input voltage and at 20°C, the center frequency of each channel was measured using a frequency counter. At 20°C, the input voltage was varied between 85% and 115% of nominal and the measurement was repeated. The temperature was increased and decreased in increments of no more than 10°C and the center frequency measurement was repeated. For each case, the measured center frequency was compared to the reference frequency taken at 20°C and 120vac.

Test Results: The EUT is compliant with the requirements of this section.

Test Engineer(s): Donald Salguero

Test Date(s): 10/26/15

Temperature (°C)	Frequency at Nominal Voltage (MHz)	Maximun deviation from frequency at 20°C (%)
Nominal frequency (MHz): 2326.25398		
50	2326.231	0.00099
40	2326.278	0.00100
30	2326.245	0.00039
20	2326.273	0.00082
10	2326.24	0.00060
0	2326.255	0.00004
-10	2326.267	0.00056
-20	2326.271	0.00073
-30	2326.274	0.00086
Voltage (AC)	Frequency at Nominal Voltage (MHz)	Maximun deviation from frequency at 20°C (%)
102	2326.26	0.00026
138	2326.264	0.00043

Table 9. Frequency Stability, Test Results, Low Band

Temperature (°C)	Frequency at Nominal Voltage (MHz)	Maximun deviation from frequency at 20°C (%)
Nominal frequency (MHz): 2338.755		
50	2338.77	0.00064
40	2338.75	0.00021
30	2338.764	0.00038
20	2338.75	0.00021
10	2338.74	0.00064
0	2338.746	0.00038
-10	2338.77	0.00064
-20	2338.765	0.00043
-30	2338.737	0.00077
Voltage (AC)	Frequency at Ambient Temperature (MHz)	Maximun deviation from frequency at 20°C (%)
102	2338.775	0.00086
138	2338.75	0.00021

Table 10. Frequency Stability, Test Results, High Band

Refer to photograph 1 of the photo exhibit document of this test report for test setup photograph.

Electromagnetic Compatibility Criteria for Satellite Communications

§2.1053 Cabinet Spurious Radiation

Test Requirement(s): §2.1053

Test Procedures: The EUT was placed on the turntable inside a semi-anechoic chamber. A biconilog receiving antenna on an antenna mast was positioned at a distance of 1 meter for measurements in the 30-1000MHz range. For all measurements above 1000MHz, a horn antenna was used at a distance of 0.5 meters and hand measurements were recorded inside the chamber with a spectrum analyzer. Measurements were recorded with both polarizations, using calibrated antennas and spectrum analyzers; no emissions of concern were observed.

Field strength measurements were converted to EIRP values and compared to the -60dBm limit using the following formula:

$EIRP (dBm) = E (dBuV/m) + 20\log(d) - 104.8$, where 'd' is the measuring distance in meters.

Test Results: The EUT is compliant with the requirements of this section.

Emission around 82MHz that appears to be above the limit is present even when the transmitter is turned off. Therefore, it is not subject to Part25 radio related limits. Emission complies to Class A digital emissions limit.

Emission that appears above the limit around 2337 MHz is not subject to the cabinet spurious radiation limit (-60dBm) since this frequency is SiriusXM fundamental emission.

Only noise floor was observed on the higher frequencies. Emissions were investigated up to the 10th harmonic.

Test Engineer(s): Donald Salguero

Test Date(s): 4/1/19

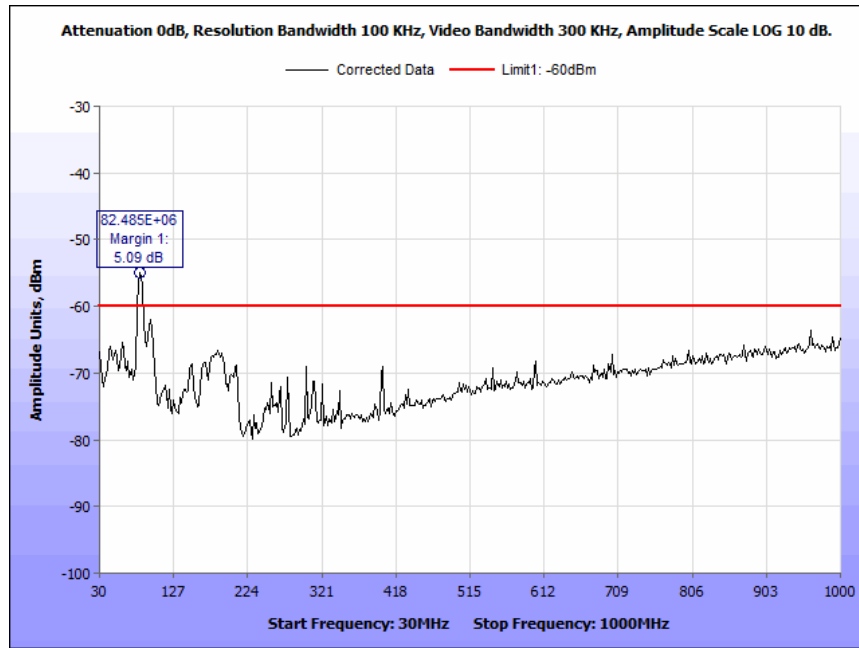

Plot 14. Cabinet Spurious Radiation, Tx Off, 30 MHz – 1 GHz

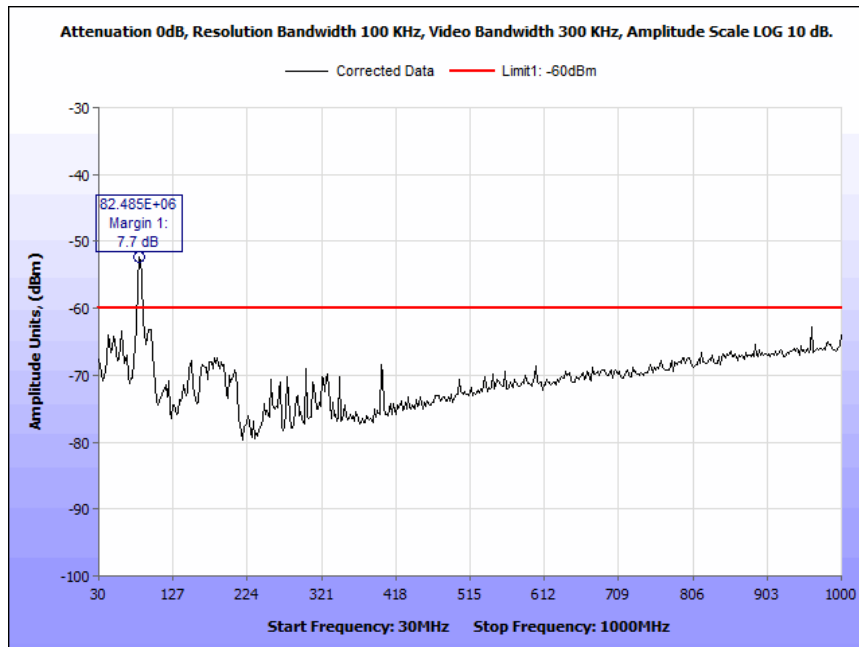

Plot 15. Cabinet Spurious Radiation, Tx On, 30 MHz – 1 GHz

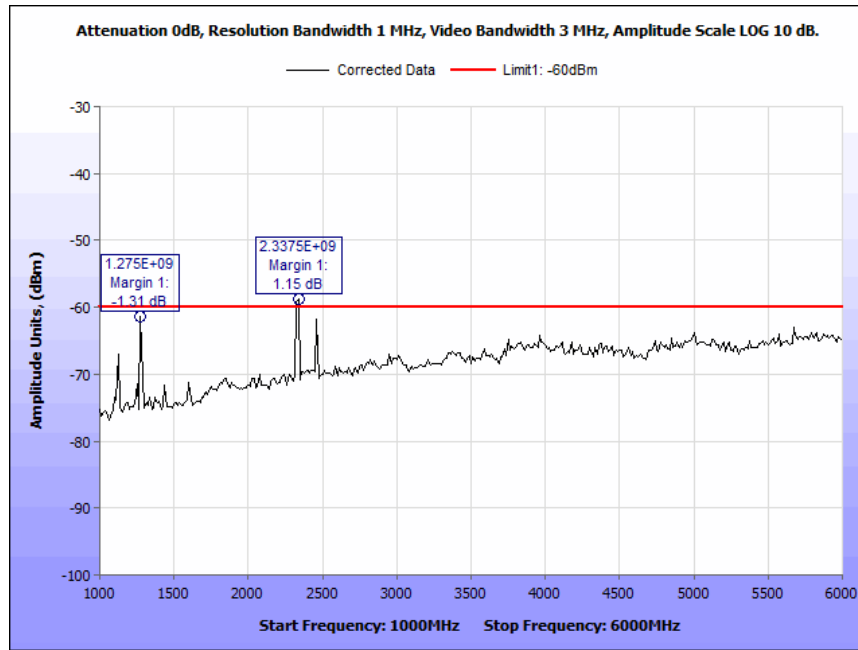

Plot 16. Cabinet Spurious Radiation, 1 GHz – 6 GHz

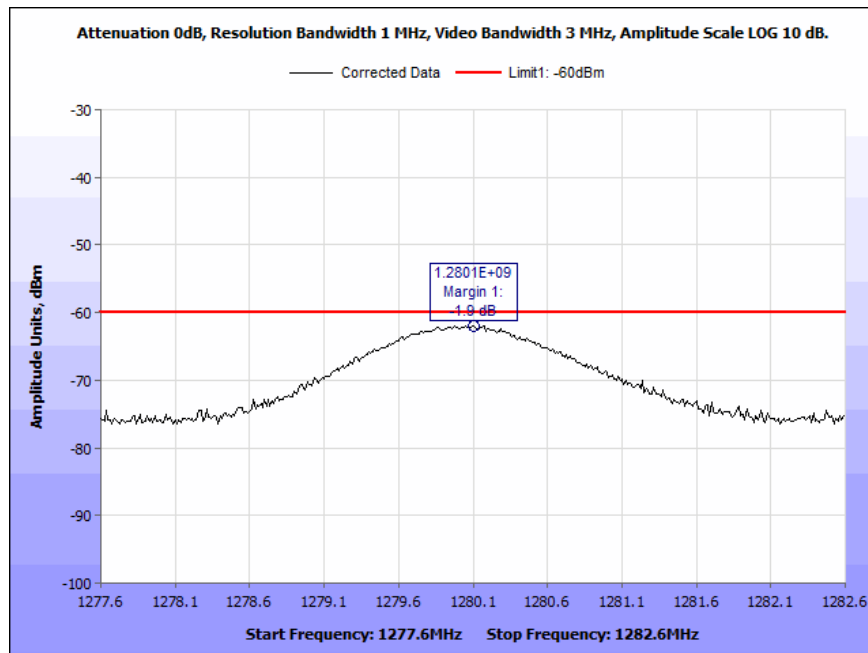

Plot 17. Cabinet Spurious Radiation, 1 GHz – 6 GHz, 1.28 GHz spur

Refer to photograph 2 and 3 of the photo exhibit document of this test report for test setup photographs.

IV. Test Equipment

Test Equipment

Calibrated test equipment utilized during testing was maintained in a current state of calibration per the requirements of ISO/IEC 17025:200.

MET #	Equipment	Manufacturer	Model#	Cal Date	Cal Due
1T2665	Antenna; Horn	EMCO	3115	6/22/2017	6/22/2019
1T4753	Antenna - Bilog	Sunol Sciences	JB6	8/30/2018	2/29/2020
1T4409	EMI Receiver	Rohde & Schwarz	ESIB7	1/4/2019	1/4/2021
1T8831	Signal Analyzer (CXA)	Keysight Technologies	N9000A	1/29/2018	7/29/2019
1T4596	AC Power Source	California Instruments	2001RP	Func Verify	
2T5826	Environmental Chamber (H5)	Thermotron	Controller THCM4-40-40	7/11/2018	7/11/2019
1T4740	Attenuator	Narda	776C-10	Func Verify	
1T4300A	SEMI-ANECHOIC CHAMBER # 1 (FCC)	EMC TEST SYSTEMS	NONE	Special	

V. Certification & User's Manual Information

Certification Information

The following is extracted from Title 47 of the Code of Federal Regulations, Part 2, Subpart I — Marketing of Radio frequency devices:

§ 2.801 Radio-frequency device defined.

As used in this part, a radio-frequency device is any device which in its operation is capable of Emitting radio-frequency energy by radiation, conduction, or other means. Radio- frequency devices include, but are not limited to:

- (a) The various types of radio communication transmitting devices described throughout this chapter.
- (b) The incidental, unintentional and intentional radiators defined in Part 15 of this chapter.*
- (c) The industrial, scientific, and medical equipment described in Part 18 of this chapter.
- (d) Any part or component thereof which in use emits radio-frequency energy by radiation, conduction, or other means.

§ 2.803 Marketing of radio frequency devices prior to equipment authorization.

- (a) Except as provided elsewhere in this chapter, no person shall sell or lease, or offer for sale or lease (including advertising for sale or lease), or import, ship or distribute for the purpose of selling or leasing or offering for sale or lease, any radio frequency device unless:
 - (1) In the case of a device subject to certification, such device has been authorized by the Commission in accordance with the rules in this chapter and is properly identified and labeled as required by §2.925 and other relevant sections in this chapter; or
 - (2) In the case of a device that is not required to have a grant of equipment authorization issued by the Commission, but which must comply with the specified technical standards prior to use, such device also complies with all applicable administrative (including verification of the equipment or authorization under a Declaration of Conformity, where required), technical, labeling and identification requirements specified in this chapter.
- (d) Notwithstanding the provisions of paragraph (a) of this section, the offer for sale solely to business, commercial, industrial, scientific or medical users (but not an offer for sale to other parties or to end users located in a residential environment) of a radio frequency device that is in the conceptual, developmental, design or pre-production stage is permitted prior to equipment authorization or, for devices not subject to the equipment authorization requirements, prior to a determination of compliance with the applicable technical requirements *provided* that the prospective buyer is advised in writing at the time of the offer for sale that the equipment is subject to the FCC rules and that the equipment will comply with the appropriate rules before delivery to the buyer or to centers of distribution.
- (e)(1) Notwithstanding the provisions of paragraph (a) of this section, prior to equipment authorization or determination of compliance with the applicable technical requirements any radio frequency

device may be operated, but not marketed, for the following purposes and under the following conditions:

- (i) *Compliance testing;*
 - (ii) Demonstrations at a trade show provided the notice contained in paragraph (c) of this section is displayed in a conspicuous location on, or immediately adjacent to, the device;
 - (iii) Demonstrations at an exhibition conducted at a business, commercial, industrial, scientific or medical location, but excluding locations in a residential environment, provided the notice contained in paragraphs (c) or (d) of this section, as appropriate, is displayed in a conspicuous location on, or immediately adjacent to, the device;
 - (iv) Evaluation of product performance and determination of customer acceptability, provided such operation takes place at the manufacturer's facilities during developmental, design or pre-production states; or
 - (v) Evaluation of product performance and determination of customer acceptability where customer acceptability of a radio frequency device cannot be determined at the manufacturer's facilities because of size or unique capability of the device, provided the device is operated at a business, commercial, industrial, scientific or medical user's site, but not at a residential site, during the development, design or pre-production stages.
- (e)(2) For the purpose of paragraphs (e)(1)(iv) and (e)(1)(v) of this section, the term *manufacturer's facilities* includes the facilities of the party responsible for compliance with the regulations and the manufacturer's premises, as well as the facilities of other entities working under the authorization of the responsible party in connection with the development and manufacture, but not the marketing, of the equipment.
- (f) For radio frequency devices subject to verification and sold solely to business, commercial, industrial, scientific and medical users (excluding products sold to other parties or for operation in a residential environment), parties responsible for verification of the devices shall have the option of ensuring compliance with the applicable technical specifications of this chapter at each end user's location after installation, provided that the purchase or lease agreement includes a proviso that such a determination of compliance be made and is the responsibility of the party responsible for verification of the equipment.

**The following is extracted from Title 47 of the Code of Federal Regulations, Part 2, Subpart J —
Equipment Authorization Procedures:**

§ 2.901 Basis and Purpose

- (a) In order to carry out its responsibilities under the Communications Act and the various treaties and international regulations, and in order to promote efficient use of the radio spectrum, the Commission has developed technical standards for radio frequency equipment and parts or components thereof. The technical standards applicable to individual types of equipment are found in that part of the rules governing the service wherein the equipment is to be operated.¹ *In addition to the technical standards provided, the rules governing the service may require that such equipment be verified by the manufacturer or importer*, be authorized under a Declaration of Conformity, or receive an equipment authorization from the Commission by one of the following procedures: certification or registration.
- (b) The following sections describe the verification procedure, the procedure for a Declaration of Conformity, and the procedures to be followed in obtaining certification from the Commission and the conditions attendant to such a grant.

§ 2.907 Certification.

- (a) Certification is an equipment authorization issued by the Commission, based on representation and test data submitted by the applicant.
- (b) Certification attaches to all units subsequently marketed by the grantee which are identical (see Section 2.908) to the sample tested except for permissive changes or other variations authorized by the Commission pursuant to Section 2.1043.

¹ In this case, the equipment is subject to the rules of Part 15. More specifically, the equipment falls under Subpart B (of Part 15), which deals with unintentional radiators.

§ 2.948 Description of measurement facilities.

- (a) Each party making measurements of equipment that is subject to an equipment authorization under Part 15 or Part 18 of this chapter, regardless of whether the measurements are filed with the Commission or kept on file by the party responsible for compliance of equipment marketed within the U.S. or its possessions, shall compile a description of the measurement facilities employed.
- (1) If the measured equipment is subject to the verification procedure, the description of the measurement facilities shall be retained by the party responsible for verification of the equipment.
- (i) *If the equipment is verified through measurements performed by an independent laboratory, it is acceptable for the party responsible for verification of the equipment to rely upon the description of the measurement facilities retained by or placed on file with the Commission by that laboratory. In this situation, the party responsible for the verification of the equipment is not required to retain a duplicate copy of the description of the measurement facilities.*
- (ii) If the equipment is verified based on measurements performed at the installation site of the equipment, no specific site calibration data is required. It is acceptable to retain the description of the measurement facilities at the site at which the measurements were performed.
- (2) If the equipment is to be authorized by the Commission under the certification procedure, the description of the measurement facilities shall be filed with the Commission's Laboratory in Columbia, Maryland. The data describing the measurement facilities need only be filed once but must be updated as changes are made to the measurement facilities or as otherwise described in this section. At least every three years, the organization responsible for filing the data with the Commission shall certify that the data on file is current.

L. Label and User's Manual Information

The following is extracted from Title 47 of the Code of Federal Regulations, Part 15, Subpart A — General:

§ 15.19 Labeling requirements.

(a) *In addition to the requirements in Part 2 of this chapter, a device subject to certification or verification shall be labeled as follows:*

- (1) Receivers associated with the operation of a licensed radio service, e.g., FM broadcast under Part 73 of this chapter, land mobile operation under Part 90, etc., shall bear the following statement in a conspicuous location on the device:

This device complies with Part 15 of the FCC Rules. Operation is subject to the condition that this device does not cause harmful interference.

- (2) A stand-alone cable input selector switch, shall bear the following statement in a conspicuous location on the device:

This device is verified to comply with Part 15 of the FCC Rules for use with cable television service.

- (3) All other devices shall bear the following statement in a conspicuous location on the device:

This device complies with Part 15 of the FCC Rules. Operation is subject to the following two conditions: (1) This device may not cause harmful interference, and (2) this device must accept any interference received, including interference that may cause undesired operation.

- (4) Where a device is constructed in two or more sections connected by wires and marketed together, the statement specified under paragraph (a) of this section is required to be affixed only to the main control unit.

- (5) When the device is so small or for such use that it is not practicable to place the statement specified under paragraph (a) of this section on it, the information required by this paragraph shall be placed in a prominent location in the instruction manual or pamphlet supplied to the user or, alternatively, shall be placed on the container in which the device is marketed. However, the FCC identifier or the unique identifier, as appropriate, must be displayed on the device.

§ 15.21 Information to user.

The users manual or instruction manual for an intentional or unintentional radiator shall caution the user that changes or modifications not expressly approved by the party responsible for compliance could void the user's authority to operate the equipment.

The following is extracted from Title 47 of the Code of Federal Regulations, Part 15, Subpart B — Unintentional Radiators:

§ 15.105 Information to the user.

- (a) For a Class B digital device or peripheral, the instructions furnished the user shall include the following or similar statement, placed in a prominent location in the text of the manual:

Note: This equipment has been tested and found to comply with the limits for a Class B digital device, pursuant to Part 15 of the FCC Rules. These limits are designed to provide reasonable protection against harmful interference when the equipment is operated in a residential environment. This equipment generates, uses, and can radiate radio frequency energy and, if not installed and used in accordance with the instruction manual, may cause harmful interference to radio communications. However, there is no guarantee that interference will not occur in a particular installation. If this equipment does cause harmful interference to radio or television reception, which can be determined by turning the equipment off and on, the user is encouraged to try to correct the interference by one or more of the following measures:

- Reorient or relocate the receiving antenna.
- Increase the separation between the equipment and receiver.
- Connect the equipment into an outlet on a circuit different from that to which the receiver is connected.
- Consult the dealer or an experienced radio/TV technician for help.

End of Report