



FCC TEST REPORT

REPORT NO.: RF111121E06

MODEL NO.: WUS-N10

FCC ID: RRKWUSN10B1

RECEIVED: Nov. 21, 2011

TESTED: Nov. 29 to Dec. 08, 2011

ISSUED: Dec. 16, 2011

APPLICANT: Alpha Networks Inc.

ADDRESS: No.8 Li-shing 7th Rd., Science-based Industrial Park,
Hsinchu, Taiwan, R.O.C.

ISSUED BY: Bureau Veritas Consumer Products Services (H.K.)
Ltd., Taoyuan Branch Hsin Chu Laboratory

LAB ADDRESS : No. 81-1, Lu Liao Keng, 9th Ling,Wu Lung Tsuen,
Chiung Lin Hsiang, Hsin Chu Hsien 307, Taiwan

TEST LOCATION (1): No. 81-1, Lu Liao Keng, 9th Ling,Wu Lung Tsuen,
Chiung Lin Hsiang, Hsin Chu Hsien 307, Taiwan

TEST LOCATION (2): No. 49, Ln. 206, Wende Rd., Shangshan Tsuen, Chiung
Lin Hsiang, Hsin Chu Hsien 307, Taiwan

This test report consists of 77 pages in total. It may be duplicated completely for legal use with the approval of the applicant. It should not be reproduced except in full, without the written approval of our laboratory. The client should not use it to claim product certification, approval, or endorsement by TAF or any government agencies. The test results in the report only apply to the tested sample.





A D T

Table of Contents

| | |
|---|----|
| RELEASE CONTROL RECORD | 4 |
| 1. CERTIFICATION | 5 |
| 2. SUMMARY OF TEST RESULTS | 6 |
| 2.1 MEASUREMENT UNCERTAINTY | 7 |
| 3. GENERAL INFORMATION | 8 |
| 3.1 GENERAL DESCRIPTION OF EUT | 8 |
| 3.2 DESCRIPTION OF TEST MODES | 10 |
| 3.2.1 TEST MODE APPLICABILITY AND TESTED CHANNEL DETAIL | 11 |
| 3.3 GENERAL DESCRIPTION OF APPLIED STANDARDS | 13 |
| 3.4 DESCRIPTION OF SUPPORT UNITS..... | 14 |
| 3.5 CONFIGURATION OF SYSTEM UNDER TEST | 14 |
| 4. TEST TYPES AND RESULTS | 15 |
| 4.1 CONDUCTED EMISSION MEASUREMENT | 15 |
| 4.1.1 LIMITS OF CONDUCTED EMISSION MEASUREMENT | 15 |
| 4.1.2 TEST INSTRUMENTS..... | 15 |
| 4.1.3 TEST PROCEDURES | 16 |
| 4.1.4 DEVIATION FROM TEST STANDARD | 16 |
| 4.1.5 TEST SETUP | 17 |
| 4.1.6 EUT OPERATING CONDITIONS | 17 |
| 4.1.7 TEST RESULTS | 18 |
| 4.2 RADIATED EMISSION MEASUREMENT | 20 |
| 4.2.1 LIMITS OF RADIATED EMISSION MEASUREMENT | 20 |
| 4.2.2 TEST INSTRUMENTS..... | 21 |
| 4.2.3 TEST PROCEDURES | 23 |
| 4.2.4 DEVIATION FROM TEST STANDARD | 23 |
| 4.2.5 TEST SETUP | 24 |
| 4.2.6 EUT OPERATING CONDITIONS | 24 |
| 4.2.7 TEST RESULTS | 25 |
| 4.3 6dB BANDWIDTH MEASUREMENT | 54 |
| 4.3.1 LIMITS OF 6dB BANDWIDTH MEASUREMENT | 54 |
| 4.3.2 TEST INSTRUMENTS..... | 54 |
| 4.3.3 TEST PROCEDURE..... | 54 |
| 4.3.4 DEVIATION FROM TEST STANDARD | 54 |
| 4.3.5 TEST SETUP | 54 |
| 4.3.6 EUT OPERATING CONDITIONS | 54 |
| 4.3.7 TEST RESULTS | 55 |
| 4.4 MAXIMUM PEAK OUTPUT POWER..... | 59 |
| 4.4.1 LIMITS OF MAXIMUM PEAK OUTPUT POWER MEASUREMENT | 59 |
| 4.4.2 INSTRUMENTS..... | 59 |
| 4.4.3 TEST PROCEDURES | 59 |



A D T

| | | |
|-------|---|----|
| 4.4.4 | DEVIATION FROM TEST STANDARD | 59 |
| 4.4.5 | TEST SETUP | 59 |
| 4.4.6 | EUT OPERATING CONDITIONS | 59 |
| 4.4.7 | TEST RESULTS | 60 |
| 4.5 | POWER SPECTRAL DENSITY MEASUREMENT | 62 |
| 4.5.1 | LIMITS OF POWER SPECTRAL DENSITY MEASUREMENT | 62 |
| 4.5.2 | TEST INSTRUMENTS..... | 62 |
| 4.5.3 | TEST PROCEDURE..... | 62 |
| 4.5.4 | DEVIATION FROM TEST STANDARD | 62 |
| 4.5.5 | TEST SETUP | 62 |
| 4.5.6 | EUT OPERATING CONDITION..... | 62 |
| 4.5.7 | TEST RESULTS | 63 |
| 4.6 | CONDUCTED OUT-BAND EMISSION MEASUREMENT | 67 |
| 4.6.1 | LIMITS OF CONDUCTED OUT-BAND EMISSION MEASUREMENT..... | 67 |
| 4.6.2 | TEST INSTRUMENTS..... | 67 |
| 4.6.3 | TEST PROCEDURE..... | 67 |
| 4.6.4 | DEVIATION FROM TEST STANDARD | 67 |
| 4.6.5 | EUT OPERATING CONDITION | 67 |
| 4.6.6 | TEST RESULTS | 67 |
| 5. | INFORMATION ON THE TESTING LABORATORIES | 76 |
| 6. | APPENDIX A - MODIFICATIONS RECORDERS FOR ENGINEERING CHANGES TO THE EUT BY THE LAB..... | 77 |



A D T

RELEASE CONTROL RECORD

| ISSUE NO. | REASON FOR CHANGE | DATE ISSUED |
|-------------|-------------------|---------------|
| RF111121E06 | Original release | Dec. 16, 2011 |



A D T

1. CERTIFICATION

PRODUCT: USB wifi module
BRAND NAME: Alpha
MODEL NO.: WUS-N10
TEST SAMPLE: MASS-PRODUCTION
TESTED: Nov. 29 to Dec. 08, 2011
APPLICANT: Alpha Networks Inc.
STANDARDS: FCC Part 15, Subpart C (Section 15.247)
ANSI C63.4-2003
ANSI C63.10-2009

The above equipment (Model: WUS-N10) has been tested by **Bureau Veritas Consumer Products Services (H.K.) Ltd., Taoyuan Branch**, and found compliance with the requirement of the above standards. The test record, data evaluation & Equipment Under Test (EUT) configurations represented herein are true and accurate accounts of the measurements of the sample's EMC characteristics under the conditions specified in this report.

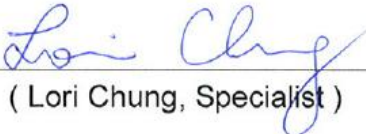
PREPARED BY :  , **DATE:** Dec. 16, 2011
(Lori Chung, Specialist)

APPROVED BY :  , **DATE:** Dec. 16, 2011
(May Chen, Deputy Manager)



A D T

2. SUMMARY OF TEST RESULTS

The EUT has been tested according to the following specifications:

| APPLIED STANDARD: FCC Part 15, Subpart C | | | |
|--|--|--------|--|
| Standard Section | Test Type and Limit | Result | Remark |
| 15.207 | AC Power Conducted Emission | PASS | Meet the requirement of limit. Minimum passing margin is -10.07dB at 0.673MHz |
| 15.247(a)(2) | Spectrum Bandwidth of a Direct Sequence Spread Spectrum System Limit: min. 500kHz | PASS | Meet the requirement of limit. |
| 15.247(b) | Maximum Peak Output Power Limit: max. 30dBm | PASS | Meet the requirement of limit. |
| 15.247(d) | Radiated Emissions Limit: Table 15.209 | PASS | Meet the requirement of limit. Minimum passing margin is -0.5dB at 4924.00 MHz. |
| 15.247(e) | Power Spectral Density Limit: max. 8dBm | PASS | Meet the requirement of limit. |
| 15.247(d) | Conducted Out-Band Emission Measurement Limit: 20dB less than the peak value of fundamental frequency | PASS | Meet the requirement of limit. |
| 15.203 | Antenna Requirement | PASS | No antenna connector is used. |



A D T

2.1 MEASUREMENT UNCERTAINTY

Where relevant, the following measurement uncertainty levels have been estimated for tests performed on the EUT as specified in CISPR 16-4-2:

This uncertainty represents an expanded uncertainty expressed at approximately the 95% confidence level using a coverage factor of $k=2$.

| Measurement | Value |
|-----------------------------------|---------|
| Conducted emissions | 2.45 dB |
| Radiated emissions (30MHz-1GHz) | 3.81dB |
| Radiated emissions (1GHz -18GHz) | 2.19 dB |
| Radiated emissions (18GHz -40GHz) | 2.56 dB |



A D T

3. GENERAL INFORMATION

3.1 GENERAL DESCRIPTION OF EUT

| | |
|------------------------------|--|
| PRODUCT | USB wifi module |
| MODEL NO. | WUS-N10 |
| FCC ID | RRKWUSN10B1 |
| POWER SUPPLY | DC 5V \pm 5% from host equipment |
| MODULATION TYPE | CCK, DQPSK, DBPSK for DSSS 64QAM, 16QAM, QPSK, BPSK for OFDM |
| MODULATION TECHNOLOGY | DSSS, OFDM |
| TRANSFER RATE | 802.11b: Up to 11Mbps 802.11g: Up to 54Mbps 802.11n (20MHz, 800ns GI): Up to 65Mbps 802.11n (40MHz, 800ns GI): Up to 135Mbps 802.11n (20MHz, 400ns GI): Up to 72.2Mbps 802.11n (40MHz, 400ns GI): Up to 150Mbps |
| FREQUENCY OPERATING | 2412MHz ~ 2462MHz |
| NUMBER OF CHANNEL | 11 for 802.11b, 802.11g, 802.11n (20MHz) 7 for 802.11n (40MHz) |
| MAXIMUM OUTPUT POWER | 802.11b: 141.3mW 802.11g: 478.6mW 802.11n (20MHz): 478.6mW 802.11n (40MHz): 446.7mW |
| ANTENNA TYPE | Please see NOTE |
| DATA CABLE | NA |
| I/O PORTS | NA |
| ASSOCIATED DEVICES | NA |



A D T

NOTE:

1. There is one antenna provided to this EUT, please refer to the following table:

| Transmitter Circuit | Manufacture | Antenna Type | Gain (dBi) | Antenna Connector |
|---------------------|-------------|--------------|------------|-------------------|
| Chain (0) | Alpha | PCB | 0.0 | NA |

2. The EUT is 1 * 1 spatial SISO (1Tx & 1Rx) without beam forming function.

3. When the EUT operating in 802.11n, the software operation, which is defined by manufacturer, MCS (Modulation and Coding Schemes) from 0 to 15.

4. The EUT was pre-tested in chamber under following test modes :

| Test Mode | Description |
|-----------|-------------|
| Mode A | X-Y plane |
| Mode B | X-Z plane |
| Mode C | Y-Z plane |

From the above modes, the worst Radiated Emissions was found in **Mode A**. Therefore only the test data of the modes were recorded in this report individually.

5. The above EUT information was declared by the manufacturer and for more detailed features description, please refer to the manufacturer's specifications or User's Manual.

3.2 DESCRIPTION OF TEST MODES

Eleven channels are provided for 802.11b, 802.11g, 802.11n (20MHz):

| CHANNEL | FREQUENCY | CHANNEL | FREQUENCY |
|---------|-----------|---------|-----------|
| 1 | 2412MHz | 7 | 2442MHz |
| 2 | 2417MHz | 8 | 2447MHz |
| 3 | 2422MHz | 9 | 2452MHz |
| 4 | 2427MHz | 10 | 2457MHz |
| 5 | 2432MHz | 11 | 2462MHz |
| 6 | 2437MHz | | |

Seven channels are provided for 802.11n (40MHz):

| CHANNEL | FREQUENCY | CHANNEL | FREQUENCY |
|---------|-----------|---------|-----------|
| 3 | 2422MHz | 7 | 2442MHz |
| 4 | 2427MHz | 8 | 2447MHz |
| 5 | 2432MHz | 9 | 2452MHz |
| 6 | 2437MHz | | |

3.2.1 TEST MODE APPLICABILITY AND TESTED CHANNEL DETAIL

| EUT CONFIGURE MODE | APPLICABLE TO | | | | | DESCRIPTION |
|--------------------|---------------|---------|--------------------|------|----|-------------|
| | PLC | RE < 1G | RE ³ 1G | APCM | OB | |
| - | √ | √ | √ | √ | √ | - |

Where **PLC**: Power Line Conducted Emission **RE < 1G**: Radiated Emission below 1GHz
RE ³ 1G: Radiated Emission above 1GHz **APCM**: Antenna Port Conducted Measurement
OB: Conducted Out-Band Emission Measurement

POWER LINE CONDUCTED EMISSION TEST:

- Pre-Scan has been conducted to determine the worst-case mode from all possible combinations between available modulations, data rates and antenna ports (if EUT with antenna diversity architecture).
- Following channel(s) was (were) selected for the final test as listed below.

| MODE | AVAILABLE CHANNEL | TESTED CHANNEL | MODULATION TECHNOLOGY | MODULATION TYPE | DATA RATE (Mbps) |
|---------|-------------------|----------------|-----------------------|-----------------|------------------|
| 802.11g | 1 to 11 | 11 | OFDM | BPSK | 6.5 |

RADIATED EMISSION TEST (BELOW 1 GHz):

- Pre-Scan has been conducted to determine the worst-case mode from all possible combinations between available modulations, data rates and antenna ports (if EUT with antenna diversity architecture).
- Following channel(s) was (were) selected for the final test as listed below.

| MODE | AVAILABLE CHANNEL | TESTED CHANNEL | MODULATION TECHNOLOGY | MODULATION TYPE | DATA RATE (Mbps) |
|---------|-------------------|----------------|-----------------------|-----------------|------------------|
| 802.11g | 1 to 11 | 11 | OFDM | BPSK | 6.5 |

RADIATED EMISSION TEST (ABOVE 1 GHz):

- Pre-Scan has been conducted to determine the worst-case mode from all possible combinations between available modulations, data rates and antenna ports (if EUT with antenna diversity architecture).
- Following channel(s) was (were) selected for the final test as listed below.

| MODE | AVAILABLE CHANNEL | TESTED CHANNEL | MODULATION TECHNOLOGY | MODULATION TYPE | DATA RATE (Mbps) |
|-----------------|-------------------|----------------|-----------------------|-----------------|------------------|
| 802.11b | 1 to 11 | 1, 6, 11 | DSSS | DBPSK | 1 |
| 802.11g | 1 to 11 | 1, 6, 11 | OFDM | BPSK | 6 |
| 802.11n (20MHz) | 1 to 11 | 1, 6, 11 | OFDM | BPSK | 6.5 |
| 802.11n (40MHz) | 3 to 9 | 3, 6, 9 | OFDM | BPSK | 13.5 |

ANTENNA PORT CONDUCTED MEASUREMENT:

- This item includes all test value of each mode, but only includes spectrum plot of worst value of each mode.
- Pre-Scan has been conducted to determine the worst-case mode from all possible combinations between available modulations, data rates and antenna ports (if EUT with antenna diversity architecture).
- Following channel(s) was (were) selected for the final test as listed below.

| MODE | AVAILABLE CHANNEL | TESTED CHANNEL | MODULATION TECHNOLOGY | MODULATION TYPE | DATA RATE (Mbps) |
|-----------------|-------------------|----------------|-----------------------|-----------------|------------------|
| 802.11b | 1 to 11 | 1, 6, 11 | DSSS | DBPSK | 1 |
| 802.11g | 1 to 11 | 1, 6, 11 | OFDM | BPSK | 6 |
| 802.11n (20MHz) | 1 to 11 | 1, 6, 11 | OFDM | BPSK | 6.5 |
| 802.11n (40MHz) | 3 to 9 | 3, 6, 9 | OFDM | BPSK | 13.5 |

CONDUCTED OUT-BAND EMISSION MEASUREMENT:

- Pre-Scan has been conducted to determine the worst-case mode from all possible combinations between available modulations, data rates and antenna ports (if EUT with antenna diversity architecture).
- Following channel(s) was (were) selected for the final test as listed below.

| MODE | AVAILABLE CHANNEL | TESTED CHANNEL | MODULATION TECHNOLOGY | MODULATION TYPE | DATA RATE (Mbps) |
|-----------------|-------------------|----------------|-----------------------|-----------------|------------------|
| 802.11b | 1 to 11 | 1, 11 | DSSS | DBPSK | 1 |
| 802.11g | 1 to 11 | 1, 11 | OFDM | BPSK | 6 |
| 802.11n (20MHz) | 1 to 11 | 1, 11 | OFDM | BPSK | 6.5 |
| 802.11n (40MHz) | 3 to 9 | 3, 9 | OFDM | BPSK | 13.5 |

※ TEST CONDITION:

| APPLICABLE TO | ENVIRONMENTAL CONDITIONS | INPUT POWER (SYSTEM) | TESTED BY |
|--------------------|--------------------------|----------------------|-------------|
| PLC | 27deg. C, 69%RH | 120Vac, 60Hz | Andy Ho |
| RE ³ 1G | 25deg. C, 70%RH | 120Vac, 60Hz | Nelson Teng |
| RE<1G | 23deg. C, 69%RH | 120Vac, 60Hz | Evan Huang |
| APCM | 25deg. C, 60%RH | 120Vac, 60Hz | Kent Liu |
| OB | 25deg. C, 60%RH | 120Vac, 60Hz | Kent Liu |



3.3 GENERAL DESCRIPTION OF APPLIED STANDARDS

The EUT is a RF product. According to the specifications of the manufacturer, it must comply with the requirements of the following standards:

FCC Part 15, Subpart C. (15.247)

ANSI C63.4-2003

ANSI C63.10-2009

All test items have been performed and recorded as per the above standards.



A D T

3.4 DESCRIPTION OF SUPPORT UNITS

The EUT has been tested as an independent unit together with other necessary accessories or support units. The following support units or accessories were used to form a representative test configuration during the tests.

| NO. | PRODUCT | BRAND | MODEL NO. | SERIAL NO. | FCC ID |
|-----|-------------------|-------|-----------|------------|---------|
| 1 | NOTEBOOK COMPUTER | DELL | PP32LA | FSLB32S | FCC DoC |

| NO. | SIGNAL CABLE DESCRIPTION OF THE ABOVE SUPPORT UNITS |
|-----|---|
| 1 | USB cable(1m) |

NOTE: All power cords of the above support units are non shielded (1.8m).

3.5 CONFIGURATION OF SYSTEM UNDER TEST

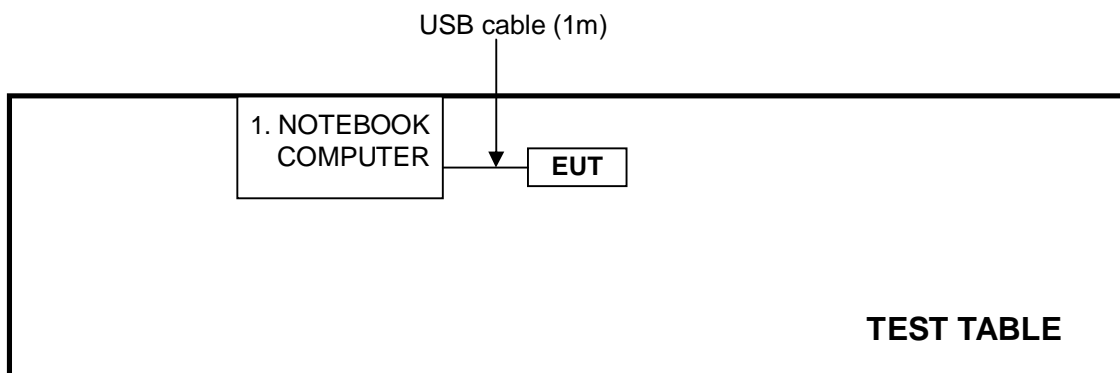

4. TEST TYPES AND RESULTS

4.1 CONDUCTED EMISSION MEASUREMENT

4.1.1 LIMITS OF CONDUCTED EMISSION MEASUREMENT

| FREQUENCY OF EMISSION (MHz) | CONDUCTED LIMIT (dB μ V) | |
|-----------------------------|------------------------------|----------|
| | Quasi-peak | Average |
| 0.15-0.5 | 66 to 56 | 56 to 46 |
| 0.5-5 | 56 | 46 |
| 5-30 | 60 | 50 |

- NOTE:**
1. The lower limit shall apply at the transition frequencies.
 2. The limit decreases in line with the logarithm of the frequency in the range of 0.15 to 0.50 MHz.
 3. All emanations from a class A/B digital device or system, including any network of conductors and apparatus connected thereto, shall not exceed the level of field strengths specified above.

4.1.2 TEST INSTRUMENTS

Test date: Dec. 08, 2011

| DESCRIPTION & MANUFACTURER | MODEL NO. | SERIAL NO. | CALIBRATED DATE | CALIBRATED UNTIL |
|---|-----------------------|------------|-----------------|------------------|
| Test Receiver | ESCS 30 | 100375 | Mar. 09, 2011 | Mar. 08, 2012 |
| Line-Impedance Stabilization Network (for EUT) | NSLK8127 | 8127-522 | Sep. 07, 2011 | Sep. 06, 2012 |
| Line-Impedance Stabilization Network (for Peripheral) | ESH3-Z5 | 848773/004 | Nov. 02, 2011 | Nov. 01, 2012 |
| RF Cable (JYEBAO) | 5DFB | COCCAB-002 | Aug. 29, 2011 | Aug. 28, 2012 |
| 50 ohms Terminator | 50 | 3 | Nov. 02, 2011 | Nov. 01, 2012 |
| Software | BV ADT_Cond_V7.3.7 | NA | NA | NA |

Note:

1. The calibration interval of the above test instruments is 12 months and the calibrations are traceable to NML/ROC and NIST/USA.
2. The test was performed in Shielded Room No. C.
3. The VCCI Con C Registration No. is C-3611.

4.1.3 TEST PROCEDURES

- a. The EUT was placed 0.4 meters from the conducting wall of the shielded room with EUT being connected to the power mains through a line impedance stabilization network (LISN). Other support units were connected to the power mains through another LISN. The two LISNs provide 50 ohm/ 50uH of coupling impedance for the measuring instrument.
- b. Both lines of the power mains connected to the EUT were checked for maximum conducted interference.
- c. The frequency range from 150kHz to 30MHz was searched. Emission levels under (Limit - 20dB) were not recorded.

4.1.4 DEVIATION FROM TEST STANDARD

No deviation

4.1.5 TEST SETUP

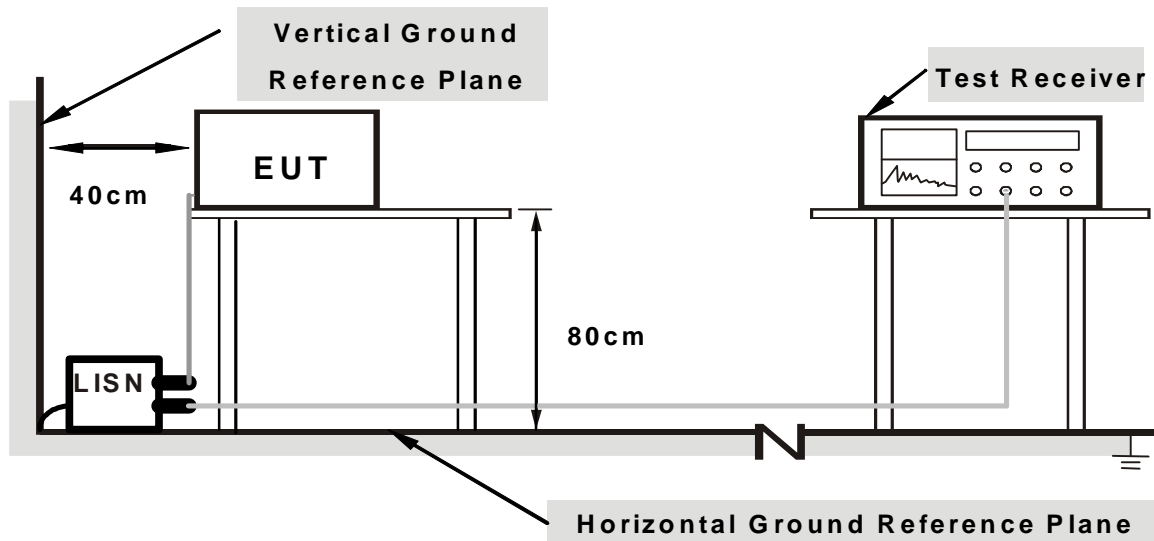

Note: 1. Support units were connected to second LISN.

2. Both of LISNs (AMN) are 80 cm from EUT and at least 80 from other units and other metal planes

For the actual test configuration, please refer to the related item – Photographs of the Test Configuration.

4.1.6 EUT OPERATING CONDITIONS

1. Turned on the power of all equipment.
2. Support unit 1 (NB) ran test program “RT3x7xQA.exe” to enable EUT under transmission/receiving condition continuously.

4.1.7 TEST RESULTS

| | | | |
|--------------|----------|----------------------|-------|
| PHASE | Line (L) | 6dB BANDWIDTH | 9 kHz |
|--------------|----------|----------------------|-------|

| No | Freq. | Corr. | Reading Value | | Emission Level | | Limit | | Margin | |
|----------|--------------|-------------|---------------|--------------|----------------|--------------|--------------|--------------|---------------|---------------|
| | [MHz] | Factor | [dB (uV)] | | [dB (uV)] | | [dB (uV)] | | (dB) | |
| | | (dB) | Q.P. | AV. | Q.P. | AV. | Q.P. | AV. | Q.P. | AV. |
| 1 | 0.240 | 0.10 | 40.43 | 31.60 | 40.53 | 31.70 | 62.10 | 52.10 | -21.57 | -20.40 |
| 2 | 0.451 | 0.11 | 37.23 | 32.97 | 37.34 | 33.08 | 56.86 | 46.86 | -19.52 | -13.78 |
| 3 | 0.556 | 0.12 | 38.40 | 35.74 | 38.52 | 35.86 | 56.00 | 46.00 | -17.48 | -10.14 |
| 4 | 0.673 | 0.13 | 37.22 | 35.80 | 37.35 | 35.93 | 56.00 | 46.00 | -18.65 | -10.07 |
| 5 | 4.113 | 0.32 | 30.06 | 21.85 | 30.38 | 22.17 | 56.00 | 46.00 | -25.62 | -23.83 |
| 6 | 20.199 | 0.78 | 30.14 | 21.24 | 30.92 | 22.02 | 60.00 | 50.00 | -29.08 | -27.98 |

- REMARKS:**
1. Q.P. and AV. are abbreviations of quasi-peak and average individually.
 2. The emission levels of other frequencies were very low against the limit.
 3. Margin value = Emission level - Limit value
 4. Correction factor = Insertion loss + Cable loss
 5. Emission Level = Correction Factor + Reading Value.

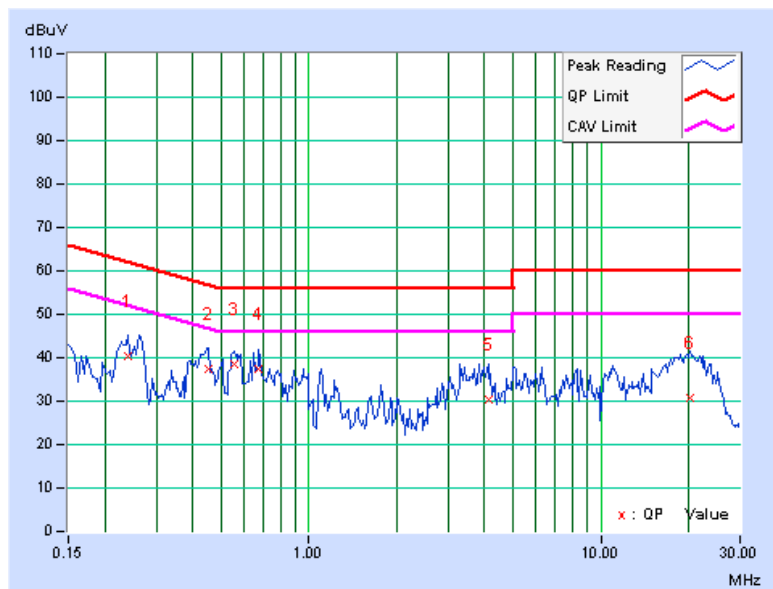

| | | | |
|--------------|-------------|----------------------|-------|
| PHASE | Neutral (N) | 6dB BANDWIDTH | 9 kHz |
|--------------|-------------|----------------------|-------|

| No | Freq. | Corr. | Reading Value | | Emission Level | | Limit | | Margin | |
|----|--------|--------|---------------|-------|----------------|-------|-----------|-------|--------|--------|
| | [MHz] | Factor | [dB (uV)] | | [dB (uV)] | | [dB (uV)] | | (dB) | |
| | | (dB) | Q.P. | AV. | Q.P. | AV. | Q.P. | AV. | Q.P. | AV. |
| 1 | 0.248 | 0.09 | 40.20 | 32.05 | 40.29 | 32.14 | 61.84 | 51.84 | -21.54 | -19.69 |
| 2 | 0.447 | 0.11 | 39.25 | 35.67 | 39.36 | 35.78 | 56.93 | 46.93 | -17.57 | -11.15 |
| 3 | 0.564 | 0.12 | 36.45 | 30.64 | 36.57 | 30.76 | 56.00 | 46.00 | -19.43 | -15.24 |
| 4 | 0.677 | 0.12 | 38.08 | 35.09 | 38.20 | 35.21 | 56.00 | 46.00 | -17.80 | -10.79 |
| 5 | 0.931 | 0.13 | 30.15 | 24.35 | 30.28 | 24.48 | 56.00 | 46.00 | -25.72 | -21.52 |
| 6 | 3.664 | 0.23 | 33.39 | 27.66 | 33.62 | 27.89 | 56.00 | 46.00 | -22.38 | -18.11 |
| 7 | 18.355 | 0.62 | 29.22 | 23.33 | 29.84 | 23.95 | 60.00 | 50.00 | -30.16 | -26.05 |

- REMARKS:**
1. Q.P. and AV. are abbreviations of quasi-peak and average individually.
 2. The emission levels of other frequencies were very low against the limit.
 3. Margin value = Emission level - Limit value
 4. Correction factor = Insertion loss + Cable loss
 5. Emission Level = Correction Factor + Reading Value.

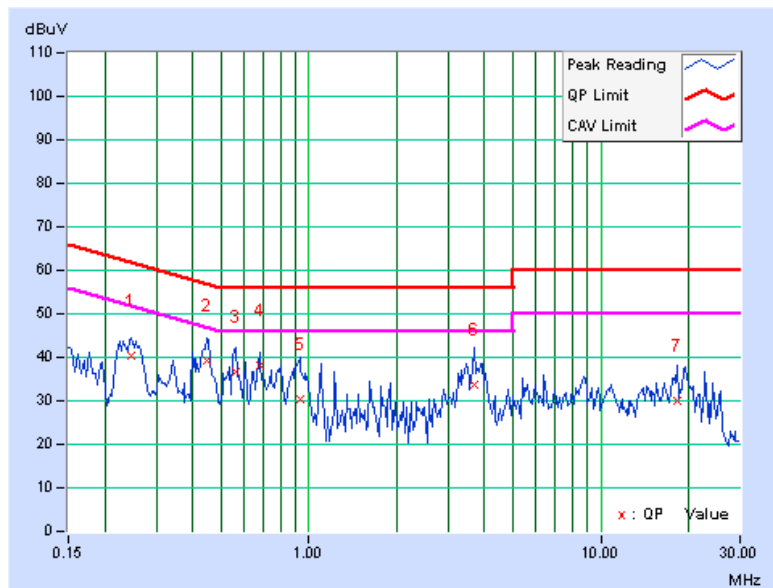

4.2 RADIATED EMISSION MEASUREMENT

4.2.1 LIMITS OF RADIATED EMISSION MEASUREMENT

Emissions radiated outside of the specified bands, shall be according to the general radiated limits in 15.209 as following:

| Frequencies (MHz) | Field strength (microvolts/meter) | Measurement distance (meters) |
|-------------------|-----------------------------------|-------------------------------|
| 0.009-0.490 | 2400/F(kHz) | 300 |
| 0.490-1.705 | 24000/F(kHz) | 30 |
| 1.705-30.0 | 30 | 30 |
| 30-88 | 100 | 3 |
| 88-216 | 150 | 3 |
| 216-960 | 200 | 3 |
| Above 960 | 500 | 3 |

NOTE:

1. The lower limit shall apply at the transition frequencies.
2. Emission level (dBuV/m) = 20 log Emission level (uV/m).
3. As shown in 15.35(b), for frequencies above 1000MHz, the field strength limits are based on average detector, however, the peak field strength of any emission shall not exceed the maximum permitted average limits, specified above by more than 20dB under any condition of modulation.
4. Section 15.205 restricted bands of operation shall compliance with the limits in Section 15.209.



A D T

4.2.2 TEST INSTRUMENTS

For below 1GHz: test date: Nov. 29, 2011

| DESCRIPTION & MANUFACTURER | MODEL NO. | SERIAL NO. | CALIBRATED DATE | CALIBRATED UNTIL |
|--------------------------------------|----------------------|-------------------------------------|-----------------|------------------|
| Agilent Spectrum Analyzer | E4446A | MY48250254 | July 12, 2011 | July 11, 2012 |
| Agilent Pre-Selector | N9039A | MY46520311 | July 12, 2011 | July 11, 2012 |
| Agilent Signal Generator | N5181A | MY49060517 | July 12, 2011 | July 11, 2012 |
| Mini-Circuits Pre-Amplifier | ZFL-1000VH2B | AMP-ZFL-03 | Nov. 15, 2011 | Nov. 14, 2012 |
| Agilent Pre-Amplifier | 8449B | 3008A02578 | July 04, 2011 | July 03, 2012 |
| SPACEK LABS | SLKKa-48-6 | 9K16 | Nov. 15, 2011 | Nov. 14, 2012 |
| SCHWARZBECK Trilog Broadband Antenna | VULB 9168 | 9168-360 | Apr. 14, 2011 | Apr. 13, 2012 |
| AISI Horn_Antenna | AIH.8018 | 0000320091110 | Nov. 14, 2011 | Nov. 13, 2012 |
| SCHWARZBECK Horn_Antenna | BBHA 9170 | 9170-424 | Oct. 07, 2011 | Oct. 06, 2012 |
| RF CABLE | NA | RF104-201 RF104-203 RF104-204 | Dec. 27, 2010 | Dec. 26, 2011 |
| RF Cable | NA | CHGCAB_001 | Oct. 07, 2011 | Oct. 06, 2012 |
| Software | ADT_Radiated_V8.7.05 | NA | NA | NA |
| CT Antenna Tower & Turn Table | NA | NA | NA | NA |

Note: 1. The calibration interval of the above test instruments is 12 months and the calibrations are traceable to NML/ROC and NIST/USA.

2. The horn antenna, preamplifier (model: 8449B) are used only for the measurement of emission frequency above 1GHz if tested.
3. The test was performed in 966 Chamber No. G.
4. The FCC Site Registration No. is 966073.
5. The VCCI Site Registration No. is G-137.
6. The CANADA Site Registration No. is IC 7450H-2.



A D T

For above 1GHz: test date: Dec. 06, 2011

| DESCRIPTION & MANUFACTURER | MODEL NO. | SERIAL NO. | CALIBRATED DATE | CALIBRATED UNTIL |
|--------------------------------------|----------------------|-------------------------------------|-----------------|------------------|
| Agilent Spectrum Analyzer | E4446A | MY48250253 | Aug. 29, 2011 | Aug. 28, 2012 |
| Agilent Pre-Selector | N9039A | MY46520310 | Aug. 29, 2011 | Aug. 28, 2012 |
| Agilent Signal Generator | N5181A | MY49060347 | July 25, 2011 | July 24, 2012 |
| LIG NEX1 Test Receiver | ER-265 | L09068005 | Oct. 24, 2011 | Oct. 23, 2012 |
| Mini-Circuits Pre-Amplifier | ZFL-1000VH2B | AMP-ZFL-04 | Nov. 15, 2011 | Nov. 14, 2012 |
| Agilent Pre-Amplifier | 8449B | 3008A02465 | Feb. 28, 2011 | Feb. 27, 2012 |
| SPACEK LABS | SLKKa-48-6 | 9K16 | Nov. 15, 2011 | Nov. 14, 2012 |
| SCHWARZBECK Trilog Broadband Antenna | VULB 9168 | 9168-361 | Apr. 14, 2011 | Apr. 13, 2012 |
| AISI Horn_Antenna | AIH.8018 | 0000220091110 | Nov. 21, 2011 | Nov. 20, 2012 |
| SCHWARZBECK Horn_Antenna | BBHA 9170 | 9170-424 | Oct. 07, 2011 | Oct. 06, 2012 |
| RF CABLE | NA | RF104-205 RF104-207 RF104-202 | Dec. 28, 2010 | Dec. 27, 2011 |
| RF Cable | NA | CHHCAB_001 | Oct. 08, 2011 | Oct. 07, 2012 |
| Software | ADT_Radiated_V8.7.05 | NA | NA | NA |
| CT Antenna Tower & Turn Table | NA | NA | NA | NA |

- Note: 1. The calibration interval of the above test instruments is 12 months and the calibrations are traceable to NML/ROC and NIST/USA.
 2. The horn antenna, preamplifier (model: 8449B) are used only for the measurement of emission frequency above 1GHz if tested.
 3. The test was performed in 966 Chamber No. H.
 4. The FCC Site Registration No. is 797305.
 5. The CANADA Site Registration No. is IC 7450H-3.

4.2.3 TEST PROCEDURES

- a. The EUT was placed on the top of a rotating table 0.8 meters above the ground at a 3 meters chamber room. The table was rotated 360 degrees to determine the position of the highest radiation.
- b. The EUT was set 3 meters away from the interference-receiving antenna, which was mounted on the top of a variable-height antenna tower.
- c. The height of antenna is varied from one meter to four meters above the ground to determine the maximum value of the field strength. Both horizontal and vertical polarizations of the antenna are set to make the measurement.
- d. For each suspected emission, the EUT was arranged to its worst case and then the antenna was tuned to heights from 1 meter to 4 meters and the rotatable table was turned from 0 degrees to 360 degrees to find the maximum reading.
- e. The test-receiver system was set to quasi-peak detect function and specified bandwidth with maximum hold mode when the test frequency is below 1 GHz.
- f. The test-receiver system was set to peak and average detect function and specified bandwidth with maximum hold mode when the test frequency is above 1 GHz. If the peak reading value also meets average limit, measurement with the average detector is unnecessary.

NOTE:

1. The resolution bandwidth and video bandwidth of test receiver/spectrum analyzer is 120kHz for Quasi-peak detection (QP) at frequency below 1GHz.
2. The resolution bandwidth of test receiver/spectrum analyzer is 1 MHz and video bandwidth is 3MHz for Peak detection at frequency above 1GHz.
3. The resolution bandwidth of test receiver/spectrum analyzer is 1MHz and the video bandwidth is 10Hz for Average detection (AV) at frequency above 1GHz.

4.2.4 DEVIATION FROM TEST STANDARD

No deviation

4.2.5 TEST SETUP

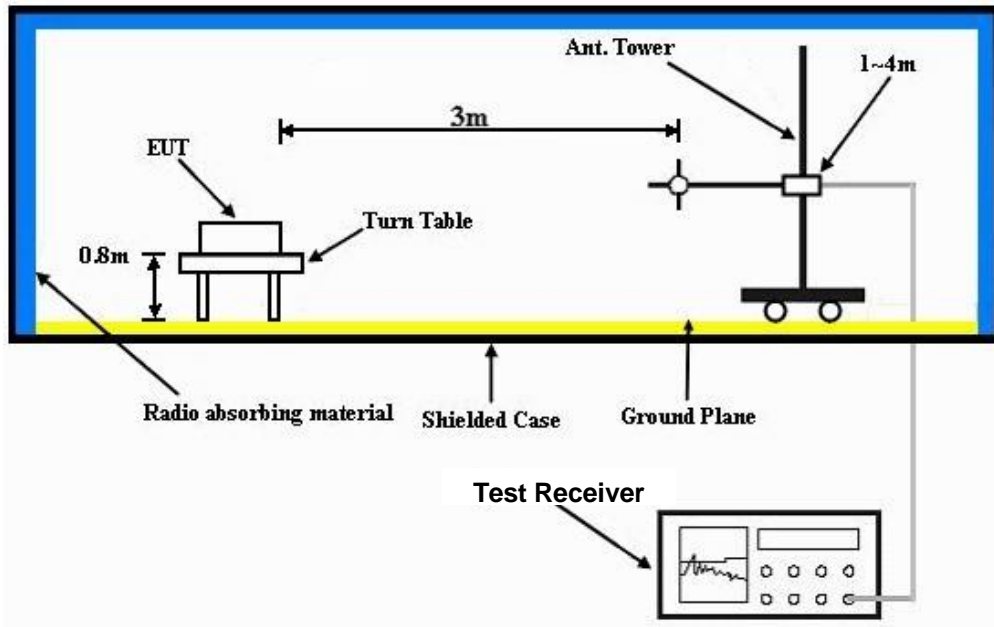

For the actual test configuration, please refer to the related item – Photographs of the Test Configuration.

4.2.6 EUT OPERATING CONDITIONS

same as 4.1.6

4.2.7 TEST RESULTS

BELOW 1GHz WORST-CASE DATA : 802.11g OFDM MODULATION

| EUT TEST CONDITION | | MEASUREMENT DETAIL | |
|--------------------------|-----------------|--------------------|---------------|
| CHANNEL | Channel 11 | FREQUENCY RANGE | Below 1000MHz |
| INPUT POWER (SYSTEM) | 120Vac, 60 Hz | DETECTOR FUNCTION | Quasi-Peak |
| ENVIRONMENTAL CONDITIONS | 23deg. C, 69%RH | TESTED BY | Evan Huang |

| ANTENNA POLARITY & TEST DISTANCE: HORIZONTAL AT 3 M | | | | | | | | |
|---|-------------|-------------------------|----------------|-------------|--------------------|----------------------|------------------|--------------------------|
| NO. | FREQ. (MHz) | EMISSION LEVEL (dBuV/m) | LIMIT (dBuV/m) | MARGIN (dB) | ANTENNA HEIGHT (m) | TABLE ANGLE (Degree) | RAW VALUE (dBuV) | CORRECTION FACTOR (dB/m) |
| 1 | 120.00 | 37.3 QP | 43.5 | -6.2 | 1.50 H | 0 | 24.73 | 12.58 |
| 2 | 249.91 | 37.1 QP | 46.0 | -8.9 | 1.00 H | 360 | 23.73 | 13.35 |
| 3 | 360.04 | 42.7 QP | 46.0 | -3.3 | 1.00 H | 335 | 25.83 | 16.89 |
| 4 | 720.05 | 36.4 QP | 46.0 | -9.6 | 1.00 H | 110 | 12.83 | 23.60 |
| 5 | 840.01 | 36.8 QP | 46.0 | -9.2 | 1.50 H | 115 | 10.34 | 26.49 |
| 6 | 959.97 | 42.1 QP | 46.0 | -3.9 | 2.00 H | 7 | 14.22 | 27.86 |

| ANTENNA POLARITY & TEST DISTANCE: VERTICAL AT 3 M | | | | | | | | |
|---|-------------|-------------------------|----------------|-------------|--------------------|----------------------|------------------|--------------------------|
| NO. | FREQ. (MHz) | EMISSION LEVEL (dBuV/m) | LIMIT (dBuV/m) | MARGIN (dB) | ANTENNA HEIGHT (m) | TABLE ANGLE (Degree) | RAW VALUE (dBuV) | CORRECTION FACTOR (dB/m) |
| 1 | 120.00 | 28.7 QP | 43.5 | -14.9 | 2.00 V | 99 | 16.07 | 12.58 |
| 2 | 135.99 | 27.1 QP | 43.5 | -16.4 | 1.50 V | 360 | 13.21 | 13.91 |
| 3 | 310.42 | 33.3 QP | 46.0 | -12.7 | 1.50 V | 73 | 17.68 | 15.59 |
| 4 | 360.04 | 35.4 QP | 46.0 | -10.6 | 2.00 V | 85 | 18.50 | 16.89 |
| 5 | 840.01 | 37.0 QP | 46.0 | -9.0 | 2.00 V | 0 | 10.49 | 26.49 |
| 6 | 959.97 | 35.8 QP | 46.0 | -10.2 | 1.50 V | 360 | 7.96 | 27.86 |

- REMARKS:**
1. Emission level (dBuV/m) = Raw Value (dBuV) + Correction Factor (dB/m).
 2. Correction Factor (dB/m) = Antenna Factor (dB/m) + Cable Factor (dB).
 3. The other emission levels were very low against the limit.
 4. Margin value = Emission level – Limit value.



A D T

ABOVE 1GHz WORST-CASE DATA

802.11b DSSS MODULATION

| EUT TEST CONDITION | | MEASUREMENT DETAIL | |
|--------------------------|-----------------|--------------------|---------------------------|
| CHANNEL | Channel 1 | FREQUENCY RANGE | 1 ~ 25GHz |
| INPUT POWER (SYSTEM) | 120Vac, 60 Hz | DETECTOR FUNCTION | Peak (PK) Average (AV) |
| ENVIRONMENTAL CONDITIONS | 25deg. C, 70%RH | TESTED BY | Nelson Teng |

ANTENNA POLARITY & TEST DISTANCE: HORIZONTAL AT 3 M

| NO. | FREQ. (MHz) | EMISSION LEVEL (dBuV/m) | LIMIT (dBuV/m) | MARGIN (dB) | ANTENNA HEIGHT (m) | TABLE ANGLE (Degree) | RAW VALUE (dBuV) | CORRECTION FACTOR (dB/m) |
|-----|-------------|-------------------------|----------------|-------------|--------------------|----------------------|------------------|--------------------------|
| 1 | 2390.00 | 57.3 PK | 74.0 | -16.7 | 1.00 H | 198 | 25.42 | 31.88 |
| 2 | 2390.00 | 44.6 AV | 54.0 | -9.4 | 1.00 H | 198 | 12.72 | 31.88 |
| 3 | *2412.00 | 103.7 PK | | | 1.00 H | 198 | 71.75 | 31.95 |
| 4 | *2412.00 | 101.4 AV | | | 1.00 H | 198 | 69.45 | 31.95 |
| 5 | 4824.00 | 56.3 PK | 74.0 | -17.7 | 1.11 H | 159 | 15.08 | 41.22 |
| 6 | 4824.00 | 52.4 AV | 54.0 | -1.6 | 1.11 H | 159 | 11.18 | 41.22 |

ANTENNA POLARITY & TEST DISTANCE: VERTICAL AT 3 M

| NO. | FREQ. (MHz) | EMISSION LEVEL (dBuV/m) | LIMIT (dBuV/m) | MARGIN (dB) | ANTENNA HEIGHT (m) | TABLE ANGLE (Degree) | RAW VALUE (dBuV) | CORRECTION FACTOR (dB/m) |
|-----|-------------|-------------------------|----------------|-------------|--------------------|----------------------|------------------|--------------------------|
| 1 | 2390.00 | 57.8 PK | 74.0 | -16.2 | 1.00 V | 265 | 25.92 | 31.88 |
| 2 | 2390.00 | 44.7 AV | 54.0 | -9.3 | 1.00 V | 265 | 12.82 | 31.88 |
| 3 | *2412.00 | 104.2 PK | | | 1.00 V | 265 | 72.25 | 31.95 |
| 4 | *2412.00 | 101.9 AV | | | 1.00 V | 265 | 69.95 | 31.95 |
| 5 | 4824.00 | 54.9 PK | 74.0 | -19.1 | 1.00 V | 191 | 13.68 | 41.22 |
| 6 | 4824.00 | 51.7 AV | 54.0 | -2.3 | 1.00 V | 191 | 10.48 | 41.22 |

- REMARKS:**
1. Emission level (dBuV/m) = Raw Value (dBuV) + Correction Factor (dB/m).
 2. Correction Factor (dB/m) = Antenna Factor (dB/m) + Cable Factor (dB).
 3. The other emission levels were very low against the limit.
 4. Margin value = Emission level – Limit value.
 5. “ * “: Fundamental frequency.



A D T

| EUT TEST CONDITION | | MEASUREMENT DETAIL | |
|--------------------------|-----------------|--------------------|---------------------------|
| CHANNEL | Channel 6 | FREQUENCY RANGE | 1 ~ 25GHz |
| INPUT POWER (SYSTEM) | 120Vac, 60 Hz | DETECTOR FUNCTION | Peak (PK) Average (AV) |
| ENVIRONMENTAL CONDITIONS | 25deg. C, 70%RH | TESTED BY | Nelson Teng |

| ANTENNA POLARITY & TEST DISTANCE: HORIZONTAL AT 3 M | | | | | | | | |
|---|-------------|-------------------------|----------------|-------------|--------------------|----------------------|------------------|--------------------------|
| NO. | FREQ. (MHz) | EMISSION LEVEL (dBuV/m) | LIMIT (dBuV/m) | MARGIN (dB) | ANTENNA HEIGHT (m) | TABLE ANGLE (Degree) | RAW VALUE (dBuV) | CORRECTION FACTOR (dB/m) |
| 1 | *2437.00 | 102.1 PK | | | 1.00 H | 272 | 70.06 | 32.04 |
| 2 | *2437.00 | 99.9 AV | | | 1.00 H | 272 | 67.86 | 32.04 |
| 3 | 4874.00 | 56.3 PK | 74.0 | -17.7 | 1.09 H | 159 | 14.94 | 41.36 |
| 4 | 4874.00 | 52.2 AV | 54.0 | -1.8 | 1.09 H | 159 | 10.84 | 41.36 |
| 5 | 7311.00 | 52.5 PK | 74.0 | -21.5 | 1.07 H | 211 | 6.83 | 45.67 |
| 6 | 7311.00 | 40.2 AV | 54.0 | -13.8 | 1.07 H | 211 | -5.47 | 45.67 |
| ANTENNA POLARITY & TEST DISTANCE: VERTICAL AT 3 M | | | | | | | | |
| NO. | FREQ. (MHz) | EMISSION LEVEL (dBuV/m) | LIMIT (dBuV/m) | MARGIN (dB) | ANTENNA HEIGHT (m) | TABLE ANGLE (Degree) | RAW VALUE (dBuV) | CORRECTION FACTOR (dB/m) |
| 1 | *2437.00 | 104.7 PK | | | 1.00 V | 191 | 72.66 | 32.04 |
| 2 | *2437.00 | 102.4 AV | | | 1.00 V | 191 | 70.36 | 32.04 |
| 3 | 4874.00 | 55.9 PK | 74.0 | -18.1 | 1.14 V | 214 | 14.54 | 41.36 |
| 4 | 4874.00 | 52.1 AV | 54.0 | -1.9 | 1.14 V | 214 | 10.74 | 41.36 |
| 5 | 7311.00 | 51.7 PK | 74.0 | -22.3 | 1.29 V | 178 | 6.03 | 45.67 |
| 6 | 7311.00 | 39.5 AV | 54.0 | -14.5 | 1.29 V | 178 | -6.17 | 45.67 |

- REMARKS:**
1. Emission level (dBuV/m) = Raw Value (dBuV) + Correction Factor (dB/m).
 2. Correction Factor (dB/m) = Antenna Factor (dB/m) + Cable Factor (dB).
 3. The other emission levels were very low against the limit.
 4. Margin value = Emission level – Limit value.
 5. “ * “: Fundamental frequency.



A D T

| EUT TEST CONDITION | | MEASUREMENT DETAIL | |
|--------------------------|-----------------|--------------------|---------------------------|
| CHANNEL | Channel 11 | FREQUENCY RANGE | 1 ~ 25GHz |
| INPUT POWER (SYSTEM) | 120Vac, 60 Hz | DETECTOR FUNCTION | Peak (PK) Average (AV) |
| ENVIRONMENTAL CONDITIONS | 25deg. C, 70%RH | TESTED BY | Nelson Teng |

| ANTENNA POLARITY & TEST DISTANCE: HORIZONTAL AT 3 M | | | | | | | | |
|---|----------------|-------------------------|----------------|-------------|--------------------|----------------------|------------------|--------------------------|
| NO. | FREQ. (MHz) | EMISSION LEVEL (dBuV/m) | LIMIT (dBuV/m) | MARGIN (dB) | ANTENNA HEIGHT (m) | TABLE ANGLE (Degree) | RAW VALUE (dBuV) | CORRECTION FACTOR (dB/m) |
| 1 | *2462.00 | 102.6 PK | | | 1.06 H | 200 | 70.48 | 32.12 |
| 2 | *2462.00 | 100.4 AV | | | 1.06 H | 200 | 68.28 | 32.12 |
| 3 | 2483.50 | 57.3 PK | 74.0 | -16.7 | 1.06 H | 200 | 25.11 | 32.19 |
| 4 | 2483.50 | 43.9 AV | 54.0 | -10.1 | 1.06 H | 200 | 11.71 | 32.19 |
| 5 | 4924.00 | 56.3 PK | 74.0 | -17.7 | 1.08 H | 169 | 14.82 | 41.48 |
| 6 | 4924.00 | 53.4 AV | 54.0 | -0.6 | 1.08 H | 169 | 11.92 | 41.48 |
| 7 | 7386.00 | 53.1 PK | 74.0 | -20.9 | 1.67 H | 214 | 7.19 | 45.91 |
| 8 | 7386.00 | 41.3 AV | 54.0 | -12.7 | 1.67 H | 214 | -4.61 | 45.91 |
| ANTENNA POLARITY & TEST DISTANCE: VERTICAL AT 3 M | | | | | | | | |
| NO. | FREQ. (MHz) | EMISSION LEVEL (dBuV/m) | LIMIT (dBuV/m) | MARGIN (dB) | ANTENNA HEIGHT (m) | TABLE ANGLE (Degree) | RAW VALUE (dBuV) | CORRECTION FACTOR (dB/m) |
| 1 | *2462.00 | 102.3 PK | | | 1.01 V | 261 | 70.18 | 32.12 |
| 2 | *2462.00 | 100.0 AV | | | 1.01 V | 261 | 67.88 | 32.12 |
| 3 | 2483.50 | 57.1 PK | 74.0 | -16.9 | 1.01 V | 261 | 24.91 | 32.19 |
| 4 | 2483.50 | 43.8 AV | 54.0 | -10.2 | 1.01 V | 261 | 11.61 | 32.19 |
| 5 | 4924.00 | 56.7 PK | 74.0 | -17.3 | 1.01 V | 214 | 15.22 | 41.48 |
| 6 | 4924.00 | 53.5 AV | 54.0 | -0.5 | 1.01 V | 214 | 12.02 | 41.48 |
| 7 | 7386.00 | 51.9 PK | 74.0 | -22.1 | 1.74 V | 214 | 5.99 | 45.91 |
| 8 | 7386.00 | 40.0 AV | 54.0 | -14.0 | 1.74 V | 214 | -5.91 | 45.91 |

- REMARKS:**
1. Emission level (dBuV/m) = Raw Value (dBuV) + Correction Factor (dB/m).
 2. Correction Factor (dB/m) = Antenna Factor (dB/m) + Cable Factor (dB).
 3. The other emission levels were very low against the limit.
 4. Margin value = Emission level – Limit value.
 5. “ * “: Fundamental frequency.



A D T

RESTRICTED BANDEDGE (802.11b MODE, CH1, HORIZONTAL)

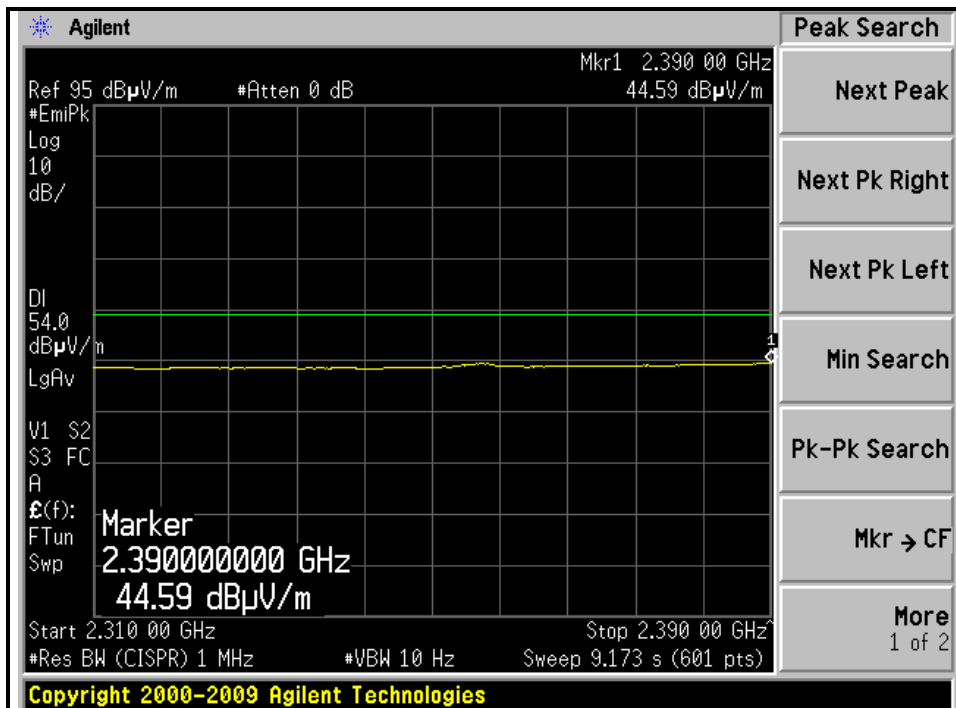
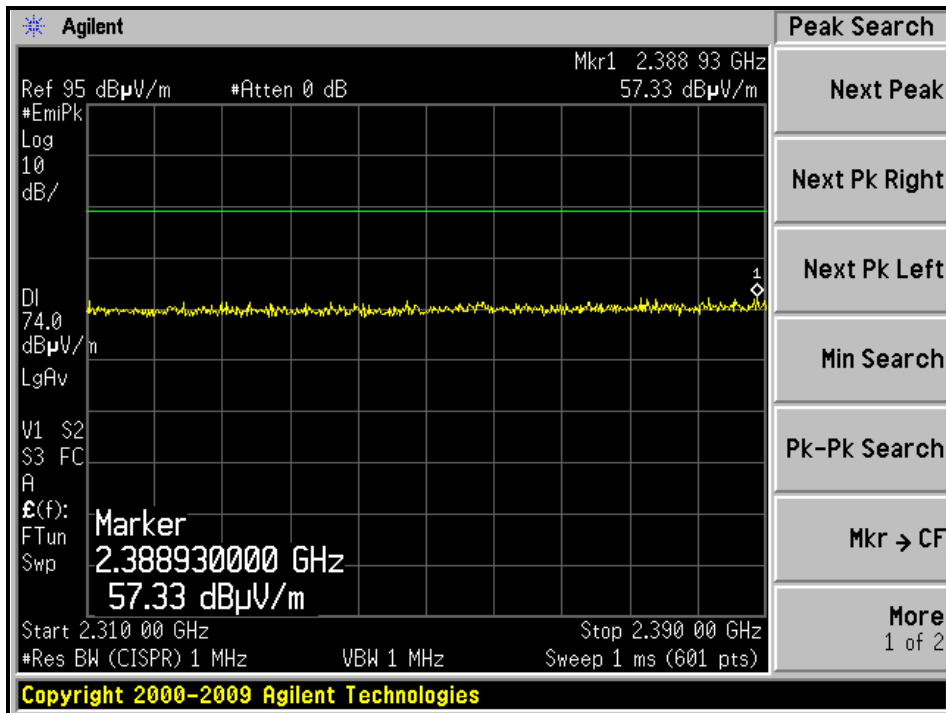



A D T

RESTRICTED BANDEDGE (802.11b MODE, CH1, VERTICAL)

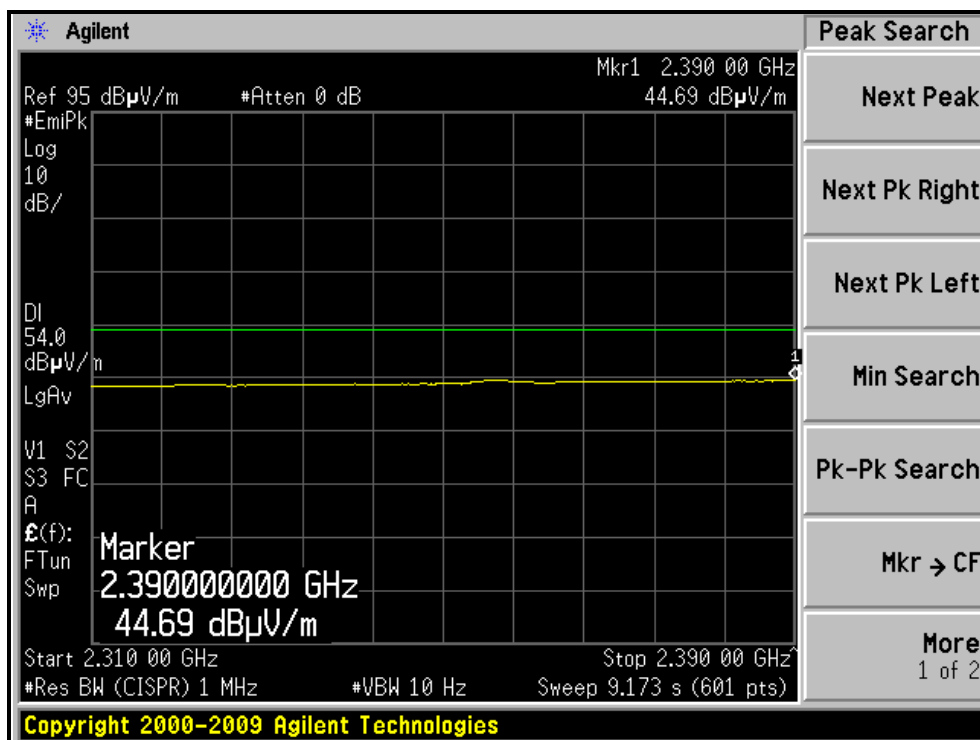
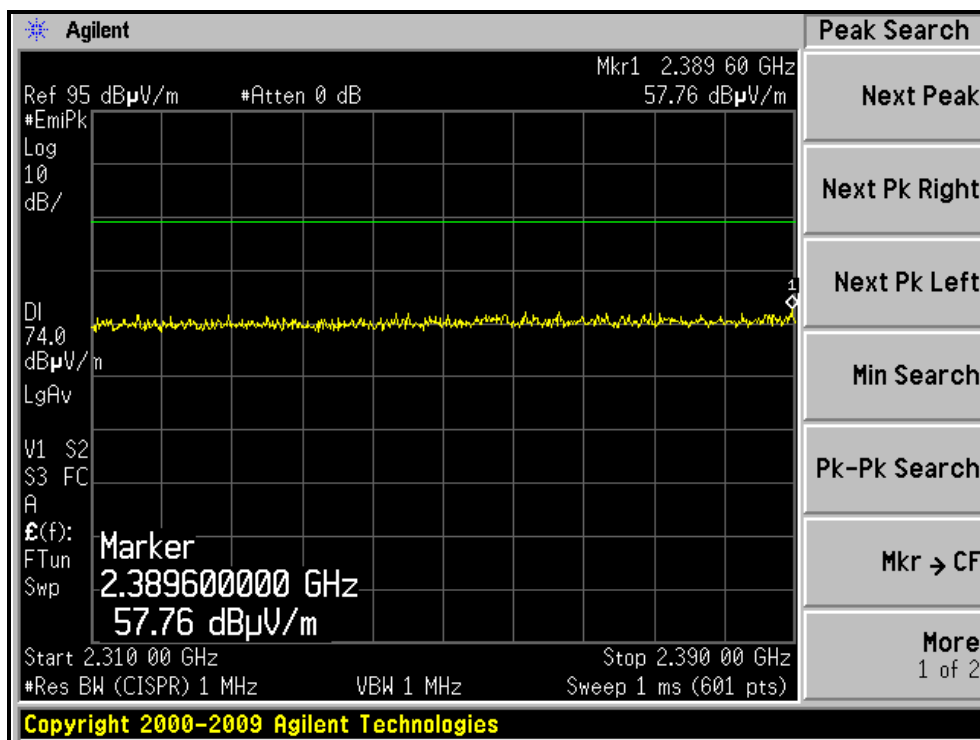

RESTRICTED BANDEDGE (802.11b MODE,CH11, HORIZONTAL)

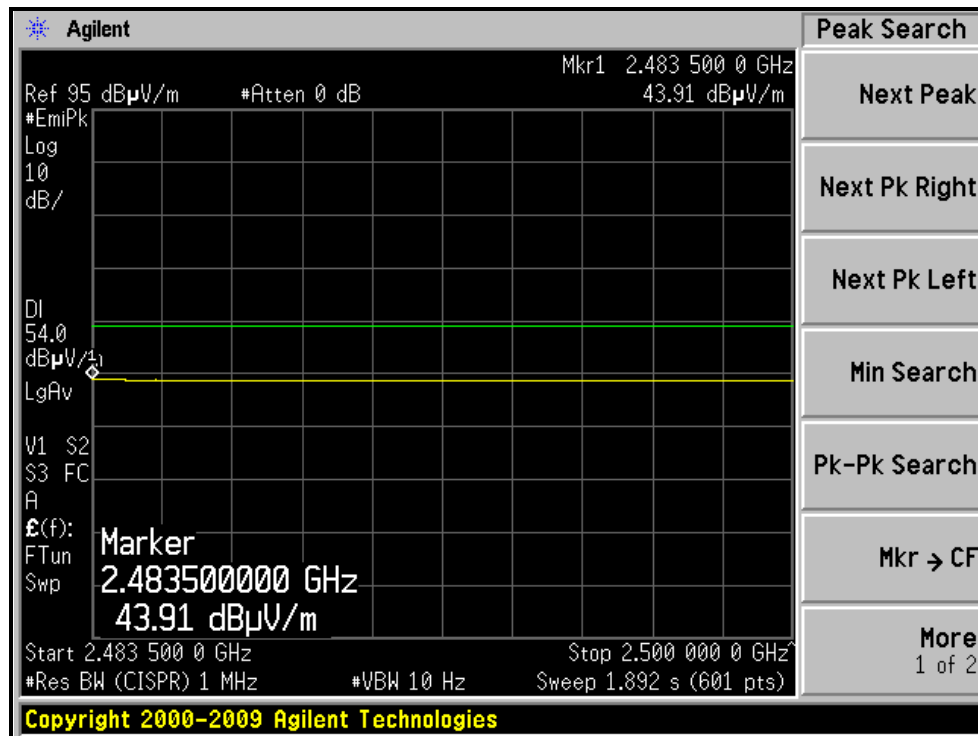
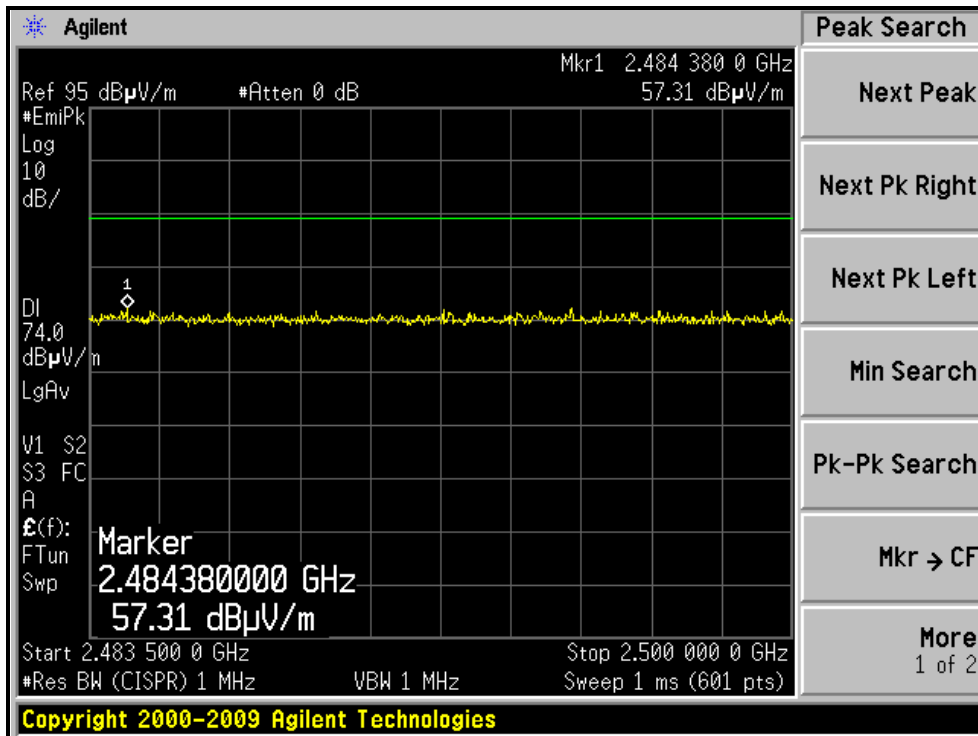



A D T

RESTRICTED BANDEDGE (802.11b MODE, CH11, VERTICAL)

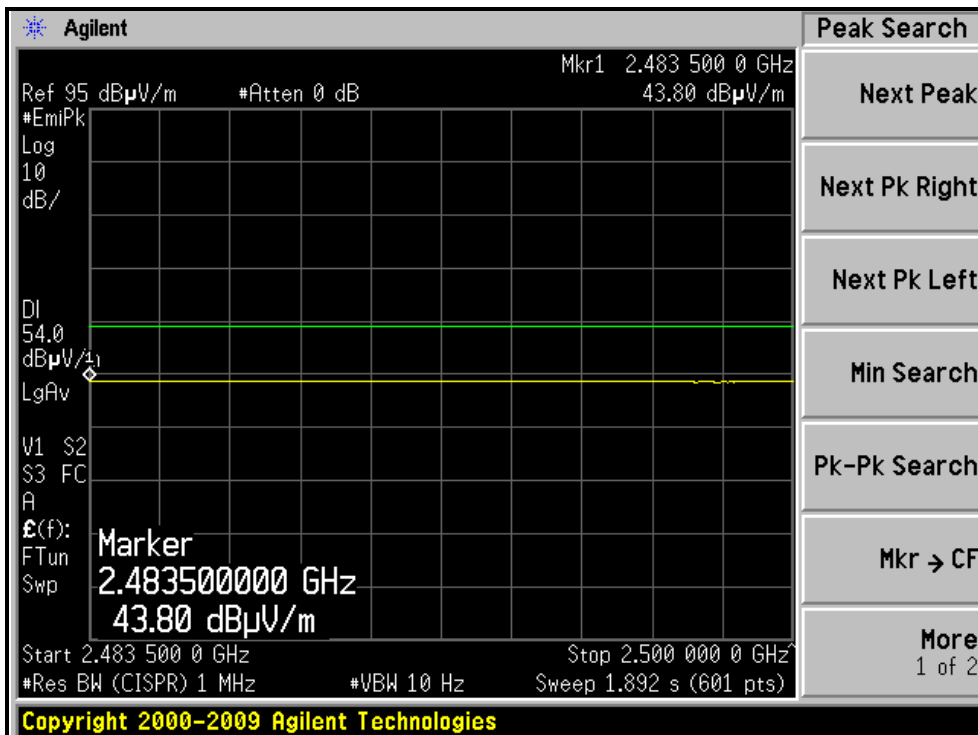
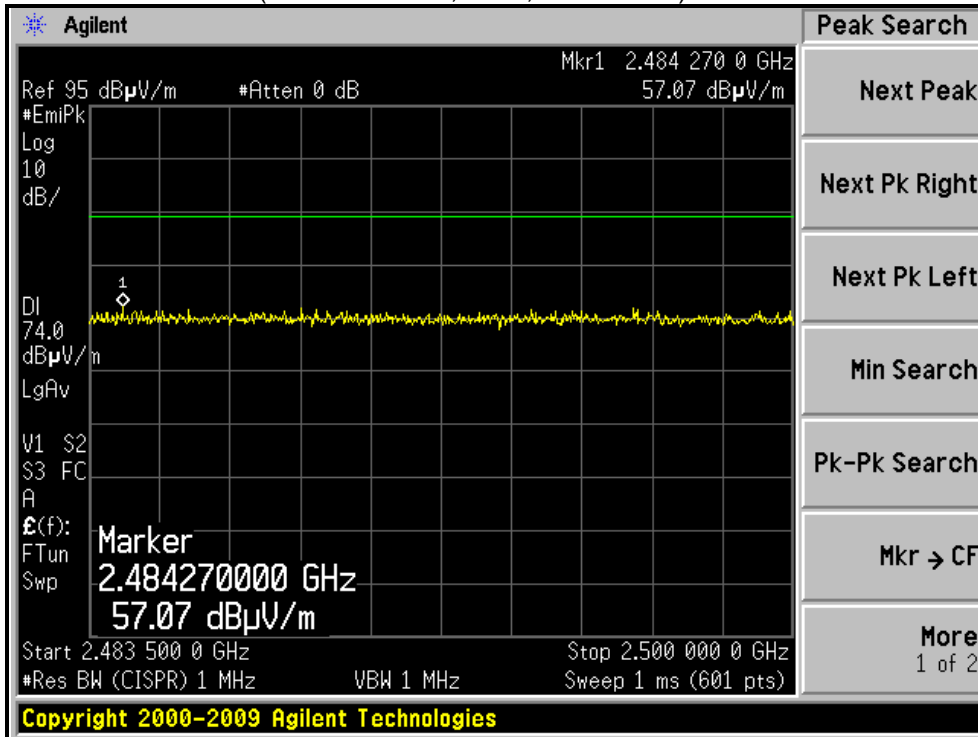



A D T

802.11g OFDM MODULATION

| EUT TEST CONDITION | | MEASUREMENT DETAIL | |
|--------------------------|-----------------|--------------------|---------------------------|
| CHANNEL | Channel 1 | FREQUENCY RANGE | 1 ~ 25GHz |
| INPUT POWER (SYSTEM) | 120Vac, 60 Hz | DETECTOR FUNCTION | Peak (PK) Average (AV) |
| ENVIRONMENTAL CONDITIONS | 25deg. C, 70%RH | TESTED BY | Nelson Teng |

| ANTENNA POLARITY & TEST DISTANCE: HORIZONTAL AT 3 M | | | | | | | | |
|---|-------------|-------------------------|----------------|-------------|--------------------|----------------------|------------------|--------------------------|
| NO. | FREQ. (MHz) | EMISSION LEVEL (dBuV/m) | LIMIT (dBuV/m) | MARGIN (dB) | ANTENNA HEIGHT (m) | TABLE ANGLE (Degree) | RAW VALUE (dBuV) | CORRECTION FACTOR (dB/m) |
| 1 | 2390.00 | 68.8 PK | 74.0 | -5.2 | 1.06 H | 260 | 36.92 | 31.88 |
| 2 | 2390.00 | 53.1 AV | 54.0 | -0.9 | 1.06 H | 260 | 21.22 | 31.88 |
| 3 | *2412.00 | 109.6 PK | | | 1.03 H | 259 | 77.65 | 31.95 |
| 4 | *2412.00 | 99.8 AV | | | 1.03 H | 259 | 67.85 | 31.95 |
| 5 | 4824.00 | 54.4 PK | 74.0 | -19.6 | 1.27 H | 126 | 13.18 | 41.22 |
| 6 | 4824.00 | 41.2 AV | 54.0 | -12.8 | 1.27 H | 126 | -0.02 | 41.22 |
| ANTENNA POLARITY & TEST DISTANCE: VERTICAL AT 3 M | | | | | | | | |
| NO. | FREQ. (MHz) | EMISSION LEVEL (dBuV/m) | LIMIT (dBuV/m) | MARGIN (dB) | ANTENNA HEIGHT (m) | TABLE ANGLE (Degree) | RAW VALUE (dBuV) | CORRECTION FACTOR (dB/m) |
| 1 | 2390.00 | 66.0 PK | 74.0 | -8.0 | 1.05 V | 202 | 34.12 | 31.88 |
| 2 | 2390.00 | 50.9 AV | 54.0 | -3.1 | 1.05 V | 202 | 19.02 | 31.88 |
| 3 | *2412.00 | 106.6 PK | | | 1.01 V | 176 | 74.65 | 31.95 |
| 4 | *2412.00 | 96.4 AV | | | 1.01 V | 176 | 64.45 | 31.95 |
| 5 | 4824.00 | 56.7 PK | 74.0 | -17.3 | 1.27 V | 202 | 15.48 | 41.22 |
| 6 | 4824.00 | 42.5 AV | 54.0 | -11.5 | 1.27 V | 202 | 1.28 | 41.22 |

- REMARKS:**
1. Emission level (dBuV/m) = Raw Value (dBuV) + Correction Factor (dB/m).
 2. Correction Factor (dB/m) = Antenna Factor (dB/m) + Cable Factor (dB).
 3. The other emission levels were very low against the limit.
 4. Margin value = Emission level – Limit value.
 5. “ * “: Fundamental frequency.



A D T

| EUT TEST CONDITION | | MEASUREMENT DETAIL | |
|--------------------------|-----------------|--------------------|---------------------------|
| CHANNEL | Channel 6 | FREQUENCY RANGE | 1 ~ 25GHz |
| INPUT POWER (SYSTEM) | 120Vac, 60 Hz | DETECTOR FUNCTION | Peak (PK) Average (AV) |
| ENVIRONMENTAL CONDITIONS | 25deg. C, 70%RH | TESTED BY | Nelson Teng |

| ANTENNA POLARITY & TEST DISTANCE: HORIZONTAL AT 3 M | | | | | | | | |
|---|-------------|-------------------------|----------------|-------------|--------------------|----------------------|------------------|--------------------------|
| NO. | FREQ. (MHz) | EMISSION LEVEL (dBuV/m) | LIMIT (dBuV/m) | MARGIN (dB) | ANTENNA HEIGHT (m) | TABLE ANGLE (Degree) | RAW VALUE (dBuV) | CORRECTION FACTOR (dB/m) |
| 1 | 2384.80 | 59.9 PK | 74.0 | -14.1 | 1.11 H | 245 | 28.03 | 31.87 |
| 2 | 2384.80 | 50.0 AV | 54.0 | -4.0 | 1.11 H | 245 | 18.13 | 31.87 |
| 3 | *2437.00 | 109.2 PK | | | 1.06 H | 261 | 77.16 | 32.04 |
| 4 | *2437.00 | 98.8 AV | | | 1.06 H | 261 | 66.76 | 32.04 |
| 5 | 2489.30 | 58.9 PK | 74.0 | -15.1 | 1.14 H | 245 | 26.69 | 32.21 |
| 6 | 2489.30 | 48.5 AV | 54.0 | -5.5 | 1.14 H | 245 | 16.29 | 32.21 |
| 7 | 4874.00 | 55.8 PK | 74.0 | -18.2 | 1.26 H | 135 | 14.44 | 41.36 |
| 8 | 4874.00 | 41.7 AV | 54.0 | -12.3 | 1.26 H | 135 | 0.34 | 41.36 |
| 9 | 7311.00 | 52.9 PK | 74.0 | -21.1 | 1.12 H | 206 | 7.23 | 45.67 |
| 10 | 7311.00 | 40.4 AV | 54.0 | -13.6 | 1.12 H | 206 | -5.27 | 45.67 |
| ANTENNA POLARITY & TEST DISTANCE: VERTICAL AT 3 M | | | | | | | | |
| NO. | FREQ. (MHz) | EMISSION LEVEL (dBuV/m) | LIMIT (dBuV/m) | MARGIN (dB) | ANTENNA HEIGHT (m) | TABLE ANGLE (Degree) | RAW VALUE (dBuV) | CORRECTION FACTOR (dB/m) |
| 1 | *2437.00 | 109.5 PK | | | 1.00 V | 188 | 77.46 | 32.04 |
| 2 | *2437.00 | 99.0 AV | | | 1.00 V | 188 | 66.96 | 32.04 |
| 3 | 4874.00 | 55.9 PK | 74.0 | -18.1 | 1.01 V | 208 | 14.54 | 41.36 |
| 4 | 4874.00 | 42.4 AV | 54.0 | -11.6 | 1.01 V | 208 | 1.04 | 41.36 |
| 5 | 7311.00 | 51.7 PK | 74.0 | -22.3 | 1.29 V | 180 | 6.03 | 45.67 |
| 6 | 7311.00 | 39.3 AV | 54.0 | -14.7 | 1.29 V | 180 | -6.37 | 45.67 |

- REMARKS:**
1. Emission level (dBuV/m) = Raw Value (dBuV) + Correction Factor (dB/m).
 2. Correction Factor (dB/m) = Antenna Factor (dB/m) + Cable Factor (dB).
 3. The other emission levels were very low against the limit.
 4. Margin value = Emission level – Limit value.
 5. “ * “: Fundamental frequency.



A D T

| EUT TEST CONDITION | | MEASUREMENT DETAIL | |
|--------------------------|-----------------|--------------------|---------------------------|
| CHANNEL | Channel 11 | FREQUENCY RANGE | 1 ~ 25GHz |
| INPUT POWER (SYSTEM) | 120Vac, 60 Hz | DETECTOR FUNCTION | Peak (PK) Average (AV) |
| ENVIRONMENTAL CONDITIONS | 25deg. C, 70%RH | TESTED BY | Nelson Teng |

| ANTENNA POLARITY & TEST DISTANCE: HORIZONTAL AT 3 M | | | | | | | | |
|---|-------------|-------------------------|----------------|-------------|--------------------|----------------------|------------------|--------------------------|
| NO. | FREQ. (MHz) | EMISSION LEVEL (dBuV/m) | LIMIT (dBuV/m) | MARGIN (dB) | ANTENNA HEIGHT (m) | TABLE ANGLE (Degree) | RAW VALUE (dBuV) | CORRECTION FACTOR (dB/m) |
| 1 | *2462.00 | 108.5 PK | | | 1.03 H | 252 | 76.38 | 32.12 |
| 2 | *2462.00 | 98.3 AV | | | 1.03 H | 252 | 66.18 | 32.12 |
| 3 | 2483.50 | 65.2 PK | 74.0 | -8.8 | 1.04 H | 252 | 33.01 | 32.19 |
| 4 | 2483.50 | 49.9 AV | 54.0 | -4.1 | 1.04 H | 252 | 17.71 | 32.19 |
| 5 | 4924.00 | 55.9 PK | 74.0 | -18.1 | 1.30 H | 149 | 14.42 | 41.48 |
| 6 | 4924.00 | 41.7 AV | 54.0 | -12.3 | 1.30 H | 149 | 0.22 | 41.48 |
| 7 | 7386.00 | 52.3 PK | 74.0 | -21.7 | 1.16 H | 212 | 6.39 | 45.91 |
| 8 | 7386.00 | 39.9 AV | 54.0 | -14.1 | 1.16 H | 212 | -6.01 | 45.91 |
| ANTENNA POLARITY & TEST DISTANCE: VERTICAL AT 3 M | | | | | | | | |
| NO. | FREQ. (MHz) | EMISSION LEVEL (dBuV/m) | LIMIT (dBuV/m) | MARGIN (dB) | ANTENNA HEIGHT (m) | TABLE ANGLE (Degree) | RAW VALUE (dBuV) | CORRECTION FACTOR (dB/m) |
| 1 | *2462.00 | 109.4 PK | | | 1.04 V | 191 | 77.28 | 32.12 |
| 2 | *2462.00 | 98.5 AV | | | 1.04 V | 191 | 66.38 | 32.12 |
| 3 | 2483.50 | 65.5 PK | 74.0 | -8.5 | 1.00 V | 187 | 33.31 | 32.19 |
| 4 | 2483.50 | 49.9 AV | 54.0 | -4.1 | 1.00 V | 187 | 17.71 | 32.19 |
| 5 | 4924.00 | 58.7 PK | 74.0 | -15.3 | 1.10 V | 203 | 17.22 | 41.48 |
| 6 | 4924.00 | 43.4 AV | 54.0 | -10.6 | 1.10 V | 203 | 1.92 | 41.48 |
| 7 | 7386.00 | 51.7 PK | 74.0 | -22.3 | 1.31 V | 191 | 5.79 | 45.91 |
| 8 | 7386.00 | 39.1 AV | 54.0 | -14.9 | 1.31 V | 191 | -6.81 | 45.91 |

- REMARKS:**
1. Emission level (dBuV/m) = Raw Value (dBuV) + Correction Factor (dB/m).
 2. Correction Factor (dB/m) = Antenna Factor (dB/m) + Cable Factor (dB).
 3. The other emission levels were very low against the limit.
 4. Margin value = Emission level – Limit value.
 5. “ * “: Fundamental frequency.

RESTRICTED BANDEDGE (802.11g MODE,CH1, HORIZONTAL)

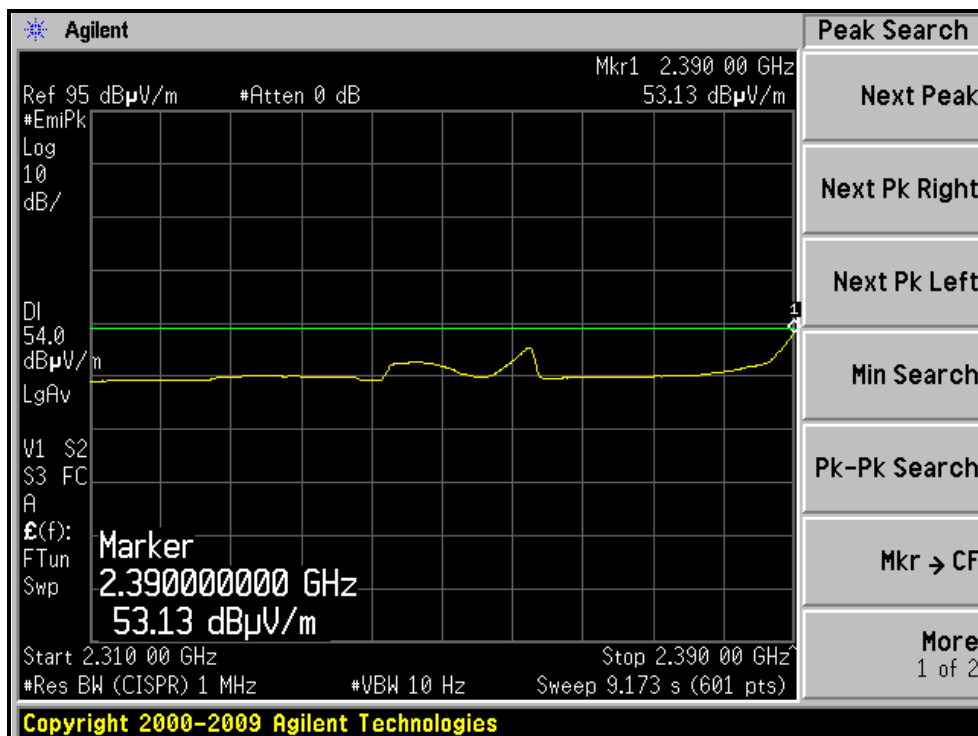
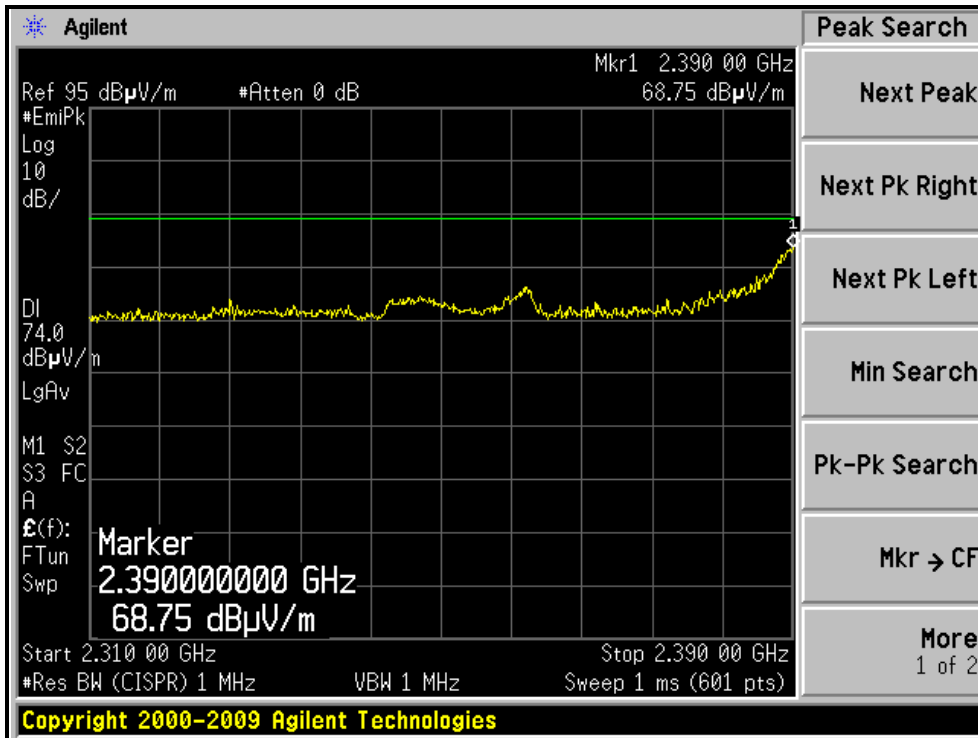



A D T

RESTRICTED BANDEDGE (802.11g MODE, CH1, VERTICAL)

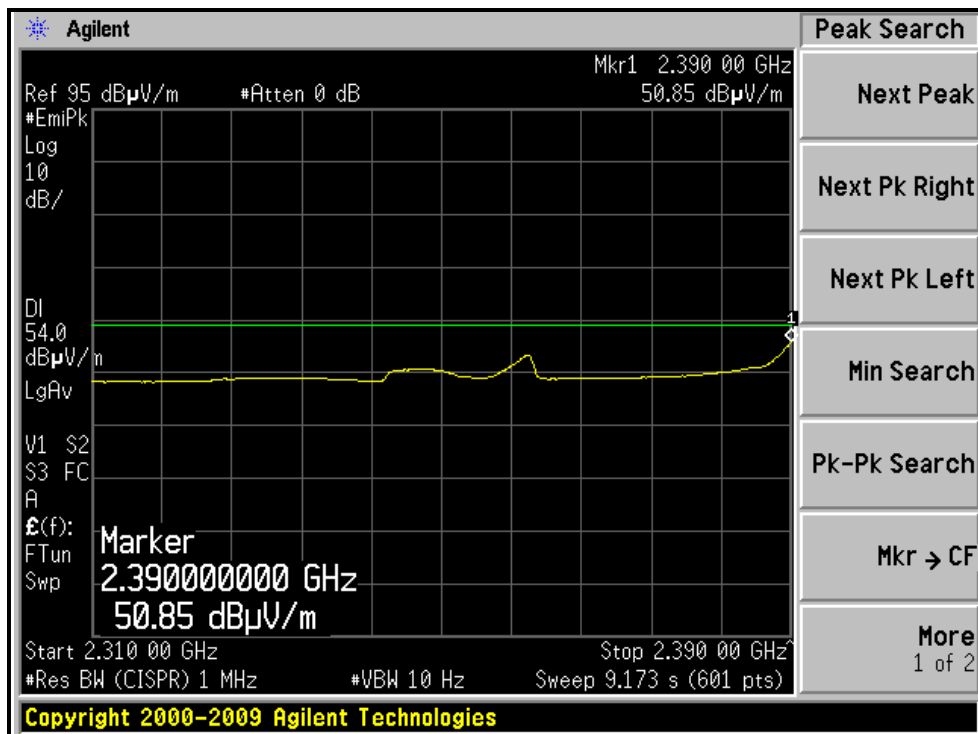
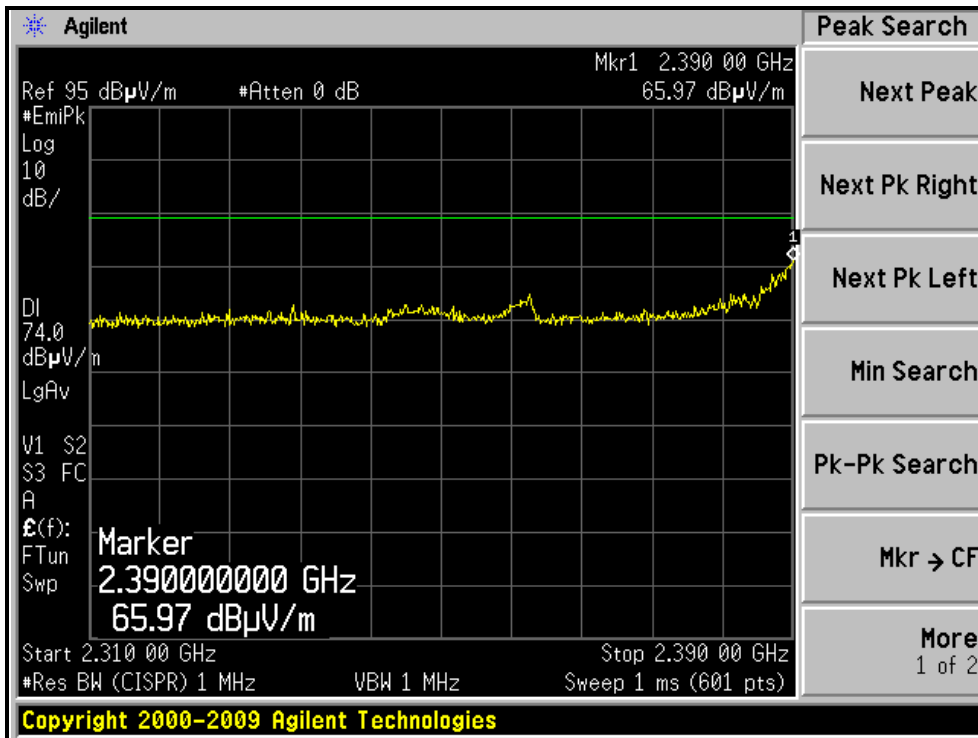

RESTRICTED BANDEDGE (802.11g MODE, CH11, HORIZONTAL)

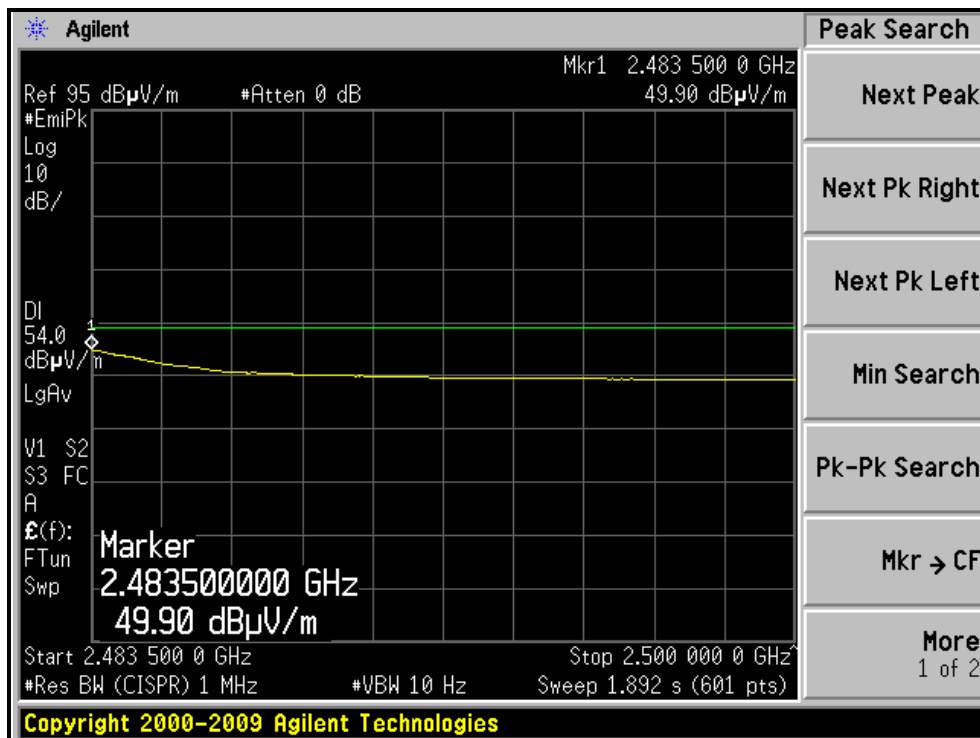
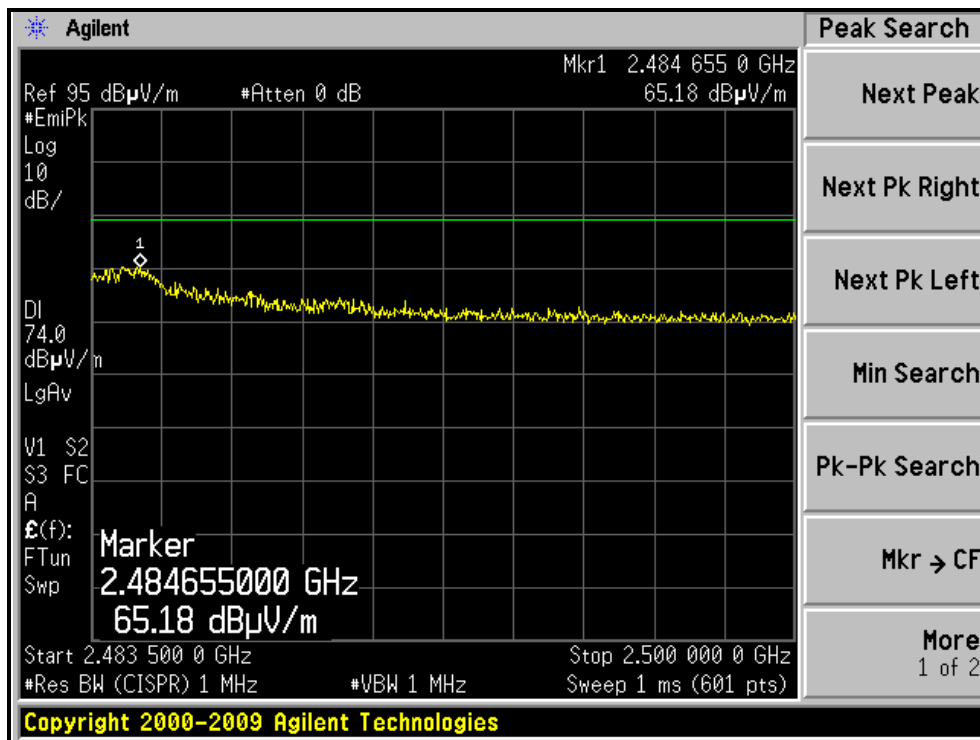

RESTRICTED BANDEDGE (802.11g MODE, CH11, VERTICAL)

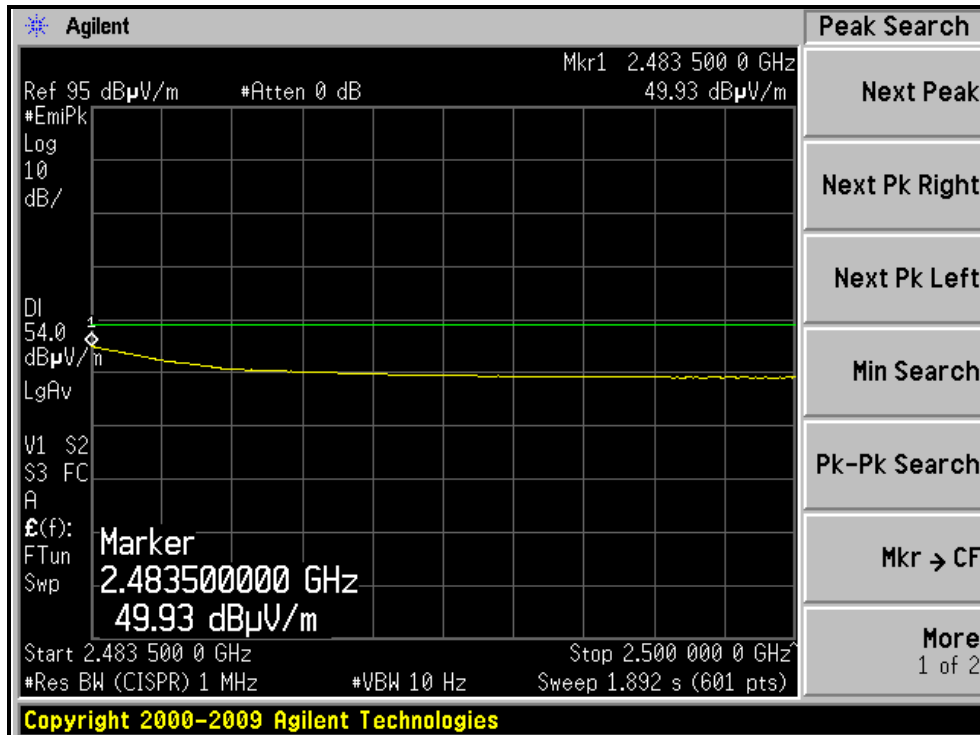
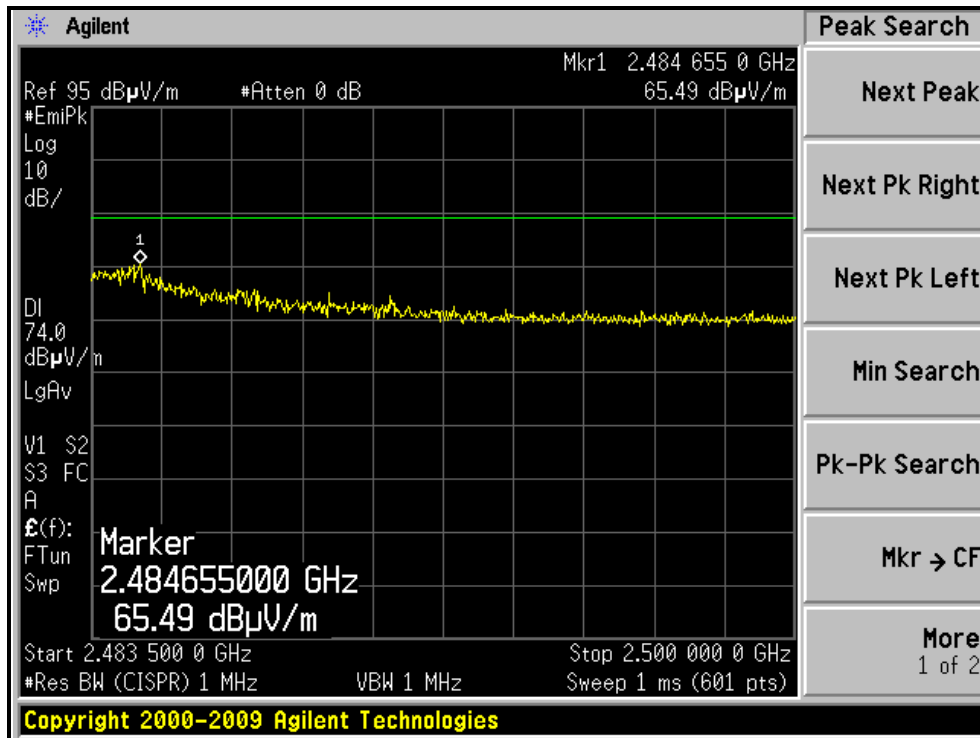



A D T

802.11n (20MHz) OFDM MODULATION

| EUT TEST CONDITION | | MEASUREMENT DETAIL | |
|--------------------------|-----------------|--------------------|---------------------------|
| CHANNEL | Channel 1 | FREQUENCY RANGE | 1 ~ 25GHz |
| INPUT POWER (SYSTEM) | 120Vac, 60 Hz | DETECTOR FUNCTION | Peak (PK) Average (AV) |
| ENVIRONMENTAL CONDITIONS | 25deg. C, 70%RH | TESTED BY | Nelson Teng |

ANTENNA POLARITY & TEST DISTANCE: HORIZONTAL AT 3 M

| NO. | FREQ. (MHz) | EMISSION LEVEL (dBuV/m) | LIMIT (dBuV/m) | MARGIN (dB) | ANTENNA HEIGHT (m) | TABLE ANGLE (Degree) | RAW VALUE (dBuV) | CORRECTION FACTOR (dB/m) |
|-----|-------------|-------------------------|----------------|-------------|--------------------|----------------------|------------------|--------------------------|
| 1 | 2390.00 | 72.8 PK | 74.0 | -1.2 | 1.09 H | 262 | 40.92 | 31.88 |
| 2 | 2390.00 | 52.8 AV | 54.0 | -1.2 | 1.09 H | 262 | 20.92 | 31.88 |
| 3 | *2412.00 | 108.6 PK | | | 1.07 H | 259 | 76.65 | 31.95 |
| 4 | *2412.00 | 98.6 AV | | | 1.07 H | 259 | 66.65 | 31.95 |
| 5 | 4824.00 | 54.4 PK | 74.0 | -19.6 | 1.30 H | 113 | 13.18 | 41.22 |
| 6 | 4824.00 | 41.4 AV | 54.0 | -12.6 | 1.30 H | 113 | 0.18 | 41.22 |

ANTENNA POLARITY & TEST DISTANCE: VERTICAL AT 3 M

| NO. | FREQ. (MHz) | EMISSION LEVEL (dBuV/m) | LIMIT (dBuV/m) | MARGIN (dB) | ANTENNA HEIGHT (m) | TABLE ANGLE (Degree) | RAW VALUE (dBuV) | CORRECTION FACTOR (dB/m) |
|-----|-------------|-------------------------|----------------|-------------|--------------------|----------------------|------------------|--------------------------|
| 1 | 2390.00 | 69.5 PK | 74.0 | -4.5 | 1.01 V | 188 | 37.62 | 31.88 |
| 2 | 2390.00 | 50.5 AV | 54.0 | -3.5 | 1.01 V | 188 | 18.62 | 31.88 |
| 3 | *2412.00 | 109.1 PK | | | 1.00 V | 186 | 77.15 | 31.95 |
| 4 | *2412.00 | 99.1 AV | | | 1.00 V | 186 | 67.15 | 31.95 |
| 5 | 4824.00 | 56.3 PK | 74.0 | -17.7 | 1.32 V | 195 | 15.08 | 41.22 |
| 6 | 4824.00 | 42.3 AV | 54.0 | -11.7 | 1.32 V | 195 | 1.08 | 41.22 |

- REMARKS:**
1. Emission level (dBuV/m) = Raw Value (dBuV) + Correction Factor (dB/m).
 2. Correction Factor (dB/m) = Antenna Factor (dB/m) + Cable Factor (dB).
 3. The other emission levels were very low against the limit.
 4. Margin value = Emission level – Limit value.
 5. “ * “: Fundamental frequency.



A D T

| EUT TEST CONDITION | | MEASUREMENT DETAIL | |
|--------------------------|-----------------|--------------------|---------------------------|
| CHANNEL | Channel 6 | FREQUENCY RANGE | 1 ~ 25GHz |
| INPUT POWER (SYSTEM) | 120Vac, 60 Hz | DETECTOR FUNCTION | Peak (PK) Average (AV) |
| ENVIRONMENTAL CONDITIONS | 25deg. C, 70%RH | TESTED BY | Nelson Teng |

ANTENNA POLARITY & TEST DISTANCE: HORIZONTAL AT 3 M

| NO. | FREQ. (MHz) | EMISSION LEVEL (dBuV/m) | LIMIT (dBuV/m) | MARGIN (dB) | ANTENNA HEIGHT (m) | TABLE ANGLE (Degree) | RAW VALUE (dBuV) | CORRECTION FACTOR (dB/m) |
|-----|-------------|-------------------------|----------------|-------------|--------------------|----------------------|------------------|--------------------------|
| 1 | 2385.33 | 60.9 PK | 74.0 | -13.1 | 1.09 H | 253 | 29.03 | 31.87 |
| 2 | 2385.33 | 50.4 AV | 54.0 | -3.6 | 1.09 H | 253 | 18.53 | 31.87 |
| 3 | *2437.00 | 108.7 PK | | | 1.10 H | 273 | 76.66 | 32.04 |
| 4 | *2437.00 | 98.6 AV | | | 1.10 H | 273 | 66.56 | 32.04 |
| 5 | 2488.69 | 60.0 PK | 74.0 | -14.0 | 1.10 H | 237 | 27.79 | 32.21 |
| 6 | 2488.69 | 48.9 AV | 54.0 | -5.1 | 1.10 H | 237 | 16.69 | 32.21 |
| 7 | 4874.00 | 56.3 PK | 74.0 | -17.7 | 1.27 H | 147 | 14.94 | 41.36 |
| 8 | 4874.00 | 42.0 AV | 54.0 | -12.0 | 1.27 H | 147 | 0.64 | 41.36 |
| 9 | 7311.00 | 52.8 PK | 74.0 | -21.2 | 1.13 H | 215 | 7.13 | 45.67 |
| 10 | 7311.00 | 40.3 AV | 54.0 | -13.7 | 1.13 H | 215 | -5.37 | 45.67 |

ANTENNA POLARITY & TEST DISTANCE: VERTICAL AT 3 M

| NO. | FREQ. (MHz) | EMISSION LEVEL (dBuV/m) | LIMIT (dBuV/m) | MARGIN (dB) | ANTENNA HEIGHT (m) | TABLE ANGLE (Degree) | RAW VALUE (dBuV) | CORRECTION FACTOR (dB/m) |
|-----|-------------|-------------------------|----------------|-------------|--------------------|----------------------|------------------|--------------------------|
| 1 | *2437.00 | 108.4 PK | | | 1.00 V | 191 | 76.36 | 32.04 |
| 2 | *2437.00 | 98.7 AV | | | 1.00 V | 191 | 66.66 | 32.04 |
| 3 | 4874.00 | 55.7 PK | 74.0 | -18.3 | 1.06 V | 218 | 14.34 | 41.36 |
| 4 | 4874.00 | 42.2 AV | 54.0 | -11.8 | 1.06 V | 218 | 0.84 | 41.36 |
| 5 | 7311.00 | 51.6 PK | 74.0 | -22.4 | 1.24 V | 193 | 5.93 | 45.67 |
| 6 | 7311.00 | 38.9 AV | 54.0 | -15.1 | 1.24 V | 193 | -6.77 | 45.67 |

- REMARKS:**
1. Emission level (dBuV/m) = Raw Value (dBuV) + Correction Factor (dB/m).
 2. Correction Factor (dB/m) = Antenna Factor (dB/m) + Cable Factor (dB).
 3. The other emission levels were very low against the limit.
 4. Margin value = Emission level – Limit value.
 5. “ * “: Fundamental frequency.



A D T

| EUT TEST CONDITION | | MEASUREMENT DETAIL | |
|--------------------------|-----------------|--------------------|---------------------------|
| CHANNEL | Channel 11 | FREQUENCY RANGE | 1 ~ 25GHz |
| INPUT POWER (SYSTEM) | 120Vac, 60 Hz | DETECTOR FUNCTION | Peak (PK) Average (AV) |
| ENVIRONMENTAL CONDITIONS | 25deg. C, 70%RH | TESTED BY | Nelson Teng |

ANTENNA POLARITY & TEST DISTANCE: HORIZONTAL AT 3 M

| NO. | FREQ. (MHz) | EMISSION LEVEL (dBuV/m) | LIMIT (dBuV/m) | MARGIN (dB) | ANTENNA HEIGHT (m) | TABLE ANGLE (Degree) | RAW VALUE (dBuV) | CORRECTION FACTOR (dB/m) |
|-----|-------------|-------------------------|----------------|-------------|--------------------|----------------------|------------------|--------------------------|
| 1 | *2462.00 | 107.9 PK | | | 1.01 H | 242 | 75.78 | 32.12 |
| 2 | *2462.00 | 97.7 AV | | | 1.01 H | 242 | 65.58 | 32.12 |
| 3 | 2483.50 | 68.5 PK | 74.0 | -5.5 | 1.02 H | 242 | 36.31 | 32.19 |
| 4 | 2483.50 | 51.8 AV | 54.0 | -2.2 | 1.02 H | 242 | 19.61 | 32.19 |
| 5 | 4924.00 | 55.8 PK | 74.0 | -18.2 | 1.28 H | 139 | 14.32 | 41.48 |
| 6 | 4924.00 | 41.8 AV | 54.0 | -12.2 | 1.28 H | 139 | 0.32 | 41.48 |
| 7 | 7386.00 | 51.8 PK | 74.0 | -22.2 | 1.18 H | 202 | 5.89 | 45.91 |
| 8 | 7386.00 | 39.5 AV | 54.0 | -14.5 | 1.18 H | 202 | -6.41 | 45.91 |

ANTENNA POLARITY & TEST DISTANCE: VERTICAL AT 3 M

| NO. | FREQ. (MHz) | EMISSION LEVEL (dBuV/m) | LIMIT (dBuV/m) | MARGIN (dB) | ANTENNA HEIGHT (m) | TABLE ANGLE (Degree) | RAW VALUE (dBuV) | CORRECTION FACTOR (dB/m) |
|-----|-------------|-------------------------|----------------|-------------|--------------------|----------------------|------------------|--------------------------|
| 1 | *2462.00 | 107.8 PK | | | 1.00 V | 190 | 75.68 | 32.12 |
| 2 | *2462.00 | 97.9 AV | | | 1.00 V | 190 | 65.78 | 32.12 |
| 3 | 2483.50 | 69.2 PK | 74.0 | -4.8 | 1.05 V | 185 | 37.01 | 32.19 |
| 4 | 2483.50 | 51.6 AV | 54.0 | -2.4 | 1.05 V | 185 | 19.41 | 32.19 |
| 5 | 4924.00 | 58.4 PK | 74.0 | -15.6 | 1.07 V | 193 | 16.92 | 41.48 |
| 6 | 4924.00 | 43.2 AV | 54.0 | -10.8 | 1.07 V | 193 | 1.72 | 41.48 |
| 7 | 7386.00 | 51.9 PK | 74.0 | -22.1 | 1.32 V | 187 | 5.99 | 45.91 |
| 8 | 7386.00 | 39.2 AV | 54.0 | -14.8 | 1.32 V | 187 | -6.71 | 45.91 |

- REMARKS:**
1. Emission level (dBuV/m) = Raw Value (dBuV) + Correction Factor (dB/m).
 2. Correction Factor (dB/m) = Antenna Factor (dB/m) + Cable Factor (dB).
 3. The other emission levels were very low against the limit.
 4. Margin value = Emission level – Limit value.
 5. “ * “: Fundamental frequency.

RESTRICTED BANDEDGE (802.11n (20MHz) MODE,CH1, HORIZONTAL)

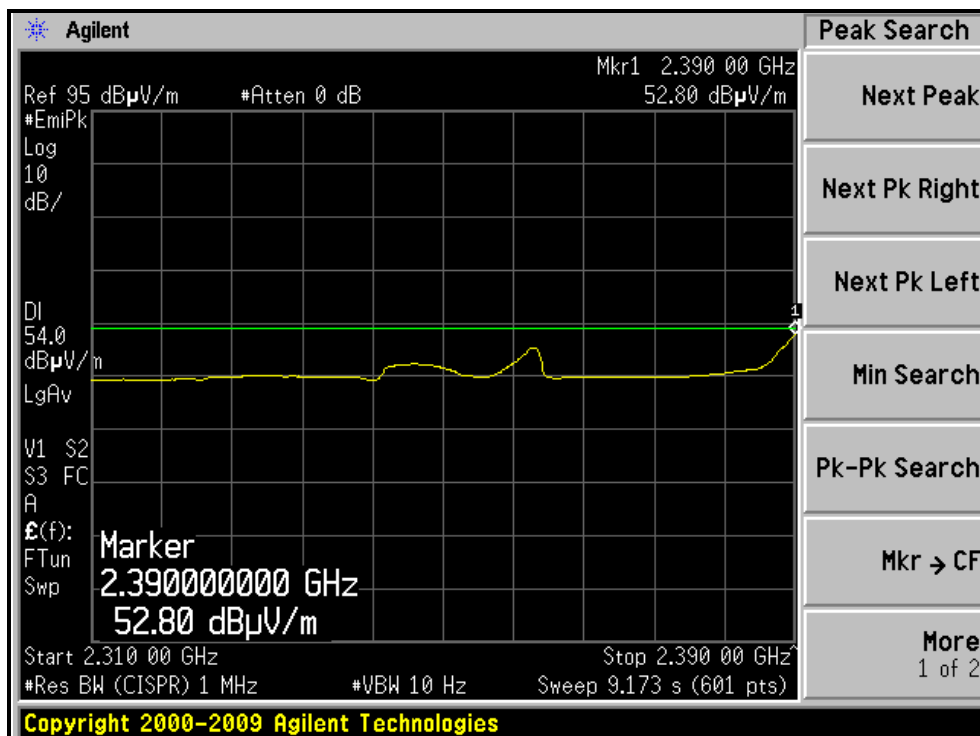
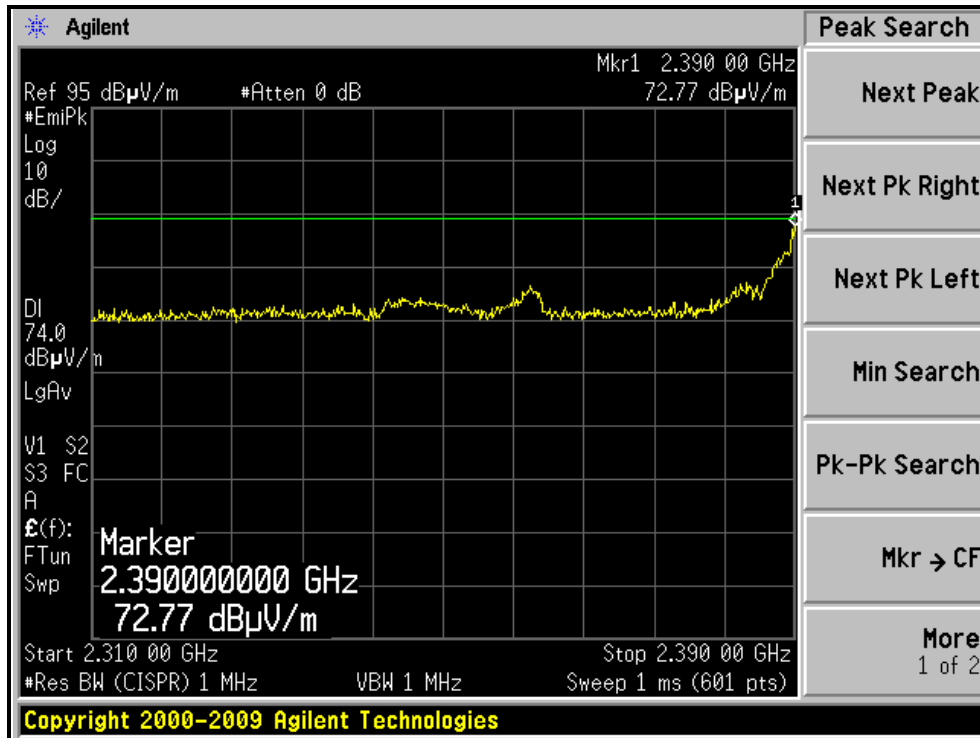



A D T

RESTRICTED BANDEDGE (802.11n (20MHz) MODE,CH1, VERTICAL)

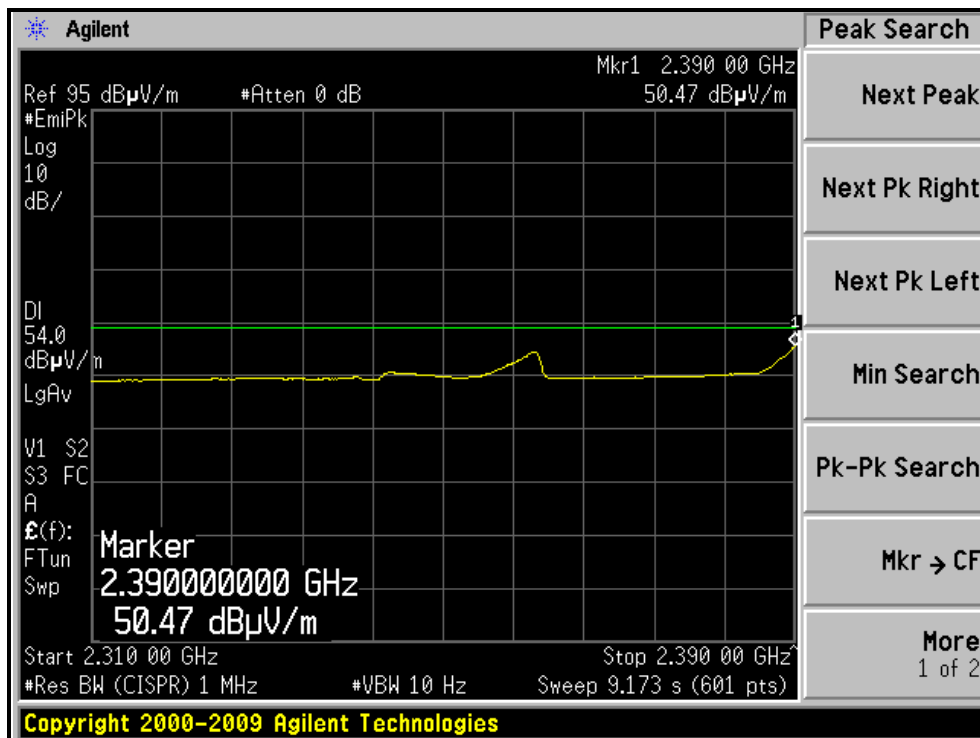
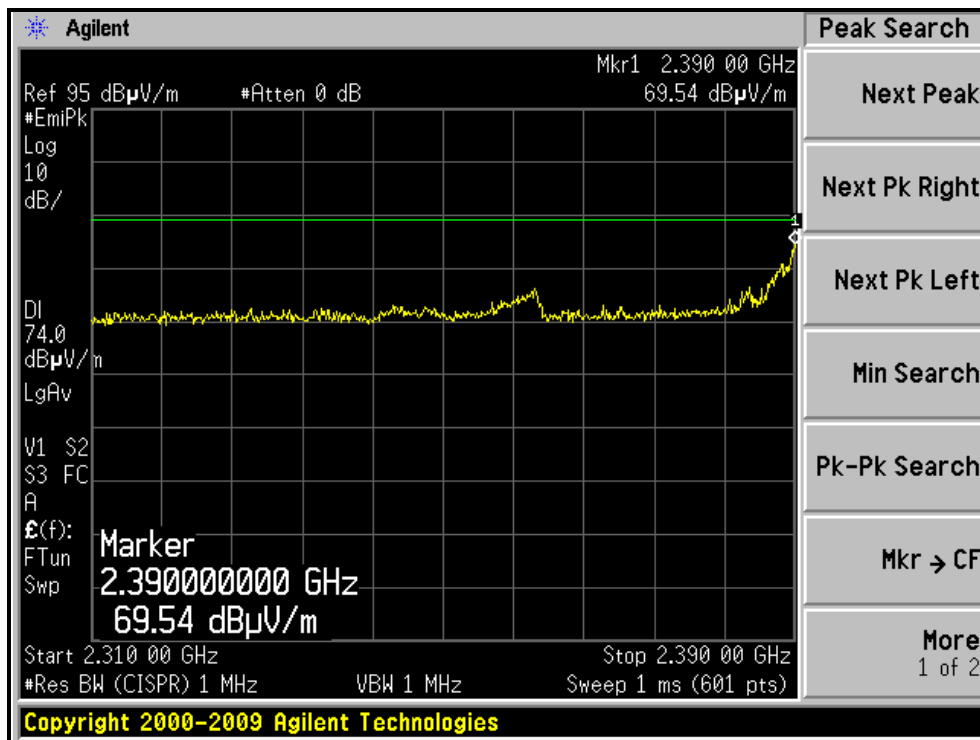



A D T

RESTRICTED BANDEDGE (802.11n (20MHz) MODE,CH11, HORIZONTAL)

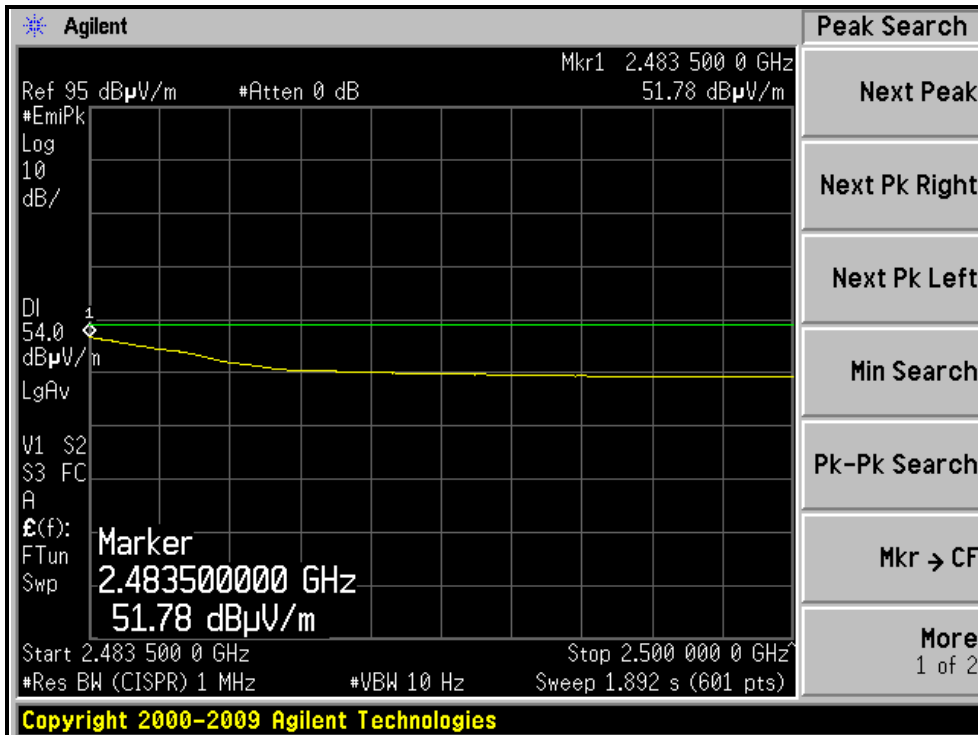
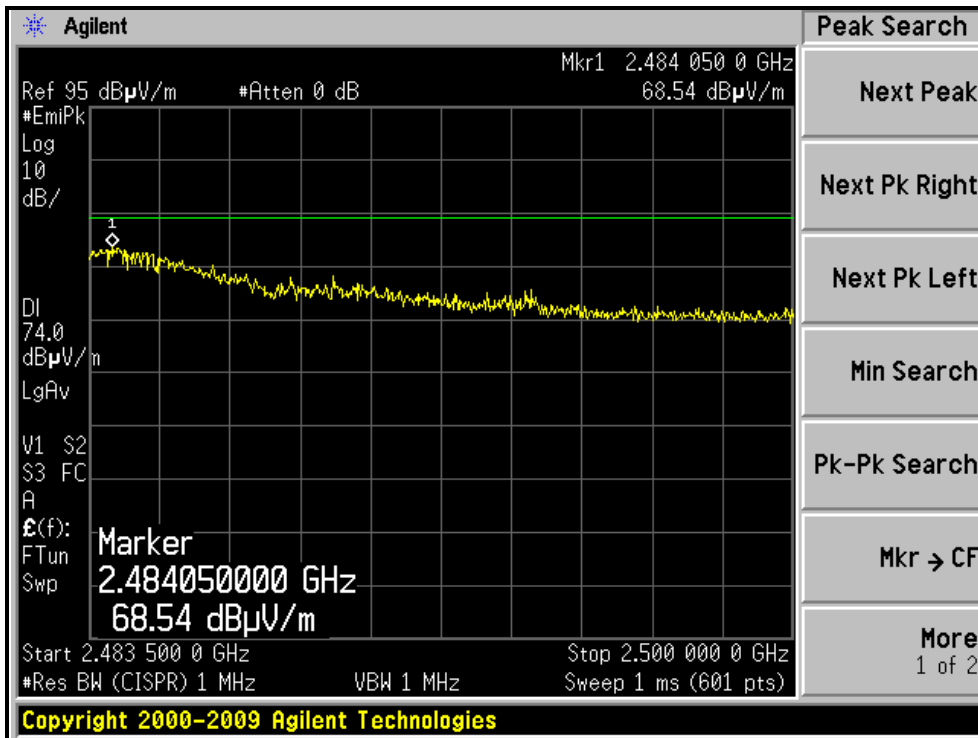



A D T

RESTRICTED BANDEDGE (802.11n (20MHz) MODE,CH11, VERTICAL)

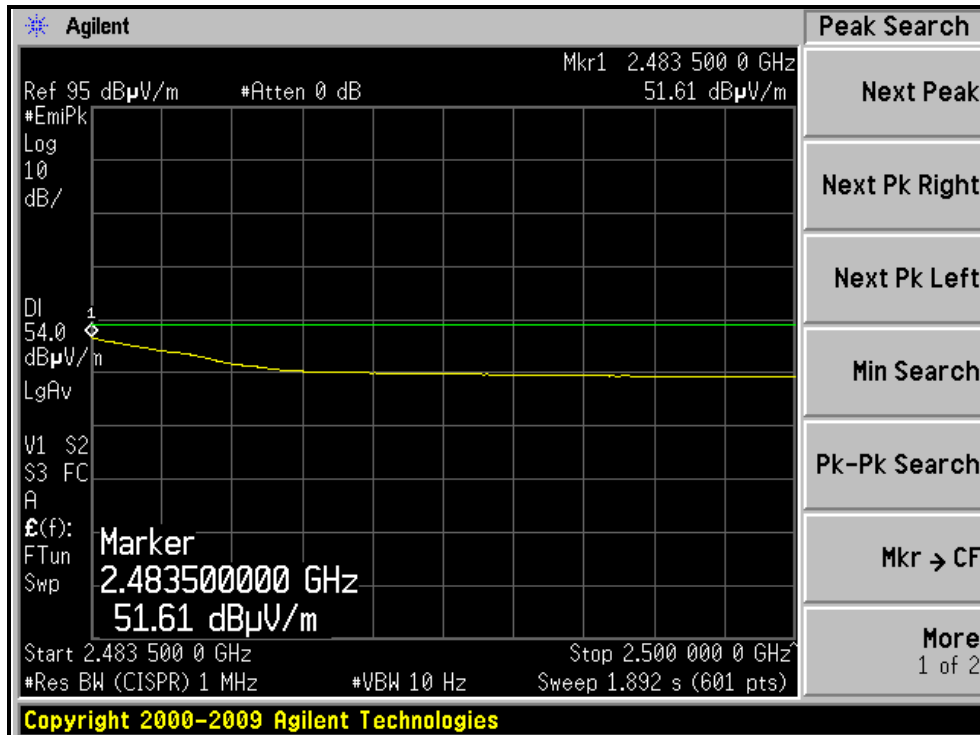
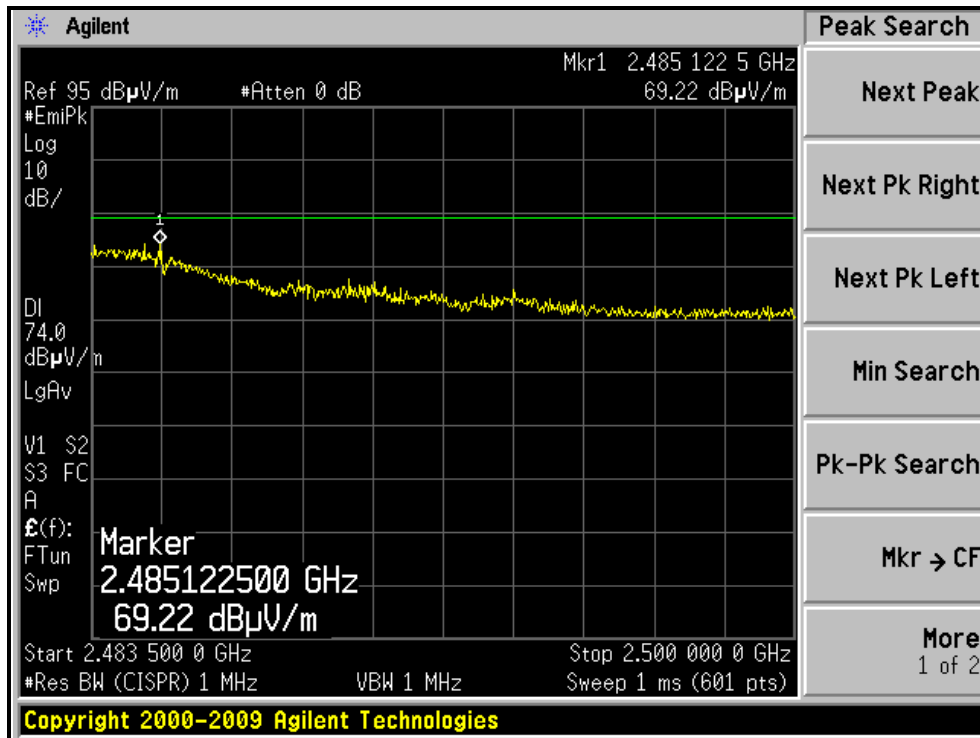



A D T

802.11n (40MHz) OFDM MODULATION

| EUT TEST CONDITION | | MEASUREMENT DETAIL | |
|--------------------------|-----------------|--------------------|---------------------------|
| CHANNEL | Channel 3 | FREQUENCY RANGE | 1 ~ 25GHz |
| INPUT POWER (SYSTEM) | 120Vac, 60 Hz | DETECTOR FUNCTION | Peak (PK) Average (AV) |
| ENVIRONMENTAL CONDITIONS | 25deg. C, 70%RH | TESTED BY | Nelson Teng |

| ANTENNA POLARITY & TEST DISTANCE: HORIZONTAL AT 3 M | | | | | | | | |
|---|-------------|-------------------------|----------------|-------------|--------------------|----------------------|------------------|--------------------------|
| NO. | FREQ. (MHz) | EMISSION LEVEL (dBuV/m) | LIMIT (dBuV/m) | MARGIN (dB) | ANTENNA HEIGHT (m) | TABLE ANGLE (Degree) | RAW VALUE (dBuV) | CORRECTION FACTOR (dB/m) |
| 1 | 2390.00 | 69.6 PK | 74.0 | -4.4 | 1.06 H | 260 | 37.72 | 31.88 |
| 2 | 2390.00 | 53.4 AV | 54.0 | -0.6 | 1.06 H | 260 | 21.52 | 31.88 |
| 3 | *2422.00 | 105.5 PK | | | 1.05 H | 260 | 73.52 | 31.98 |
| 4 | *2422.00 | 92.4 AV | | | 1.05 H | 260 | 60.42 | 31.98 |
| 5 | 4844.00 | 53.1 PK | 74.0 | -20.9 | 1.27 H | 126 | 11.82 | 41.28 |
| 6 | 4844.00 | 39.5 AV | 54.0 | -14.5 | 1.27 H | 126 | -1.78 | 41.28 |
| 7 | 7266.00 | 50.9 PK | 74.0 | -23.1 | 1.03 H | 212 | 5.35 | 45.55 |
| 8 | 7266.00 | 38.4 AV | 54.0 | -15.6 | 1.03 H | 212 | -7.15 | 45.55 |
| ANTENNA POLARITY & TEST DISTANCE: VERTICAL AT 3 M | | | | | | | | |
| NO. | FREQ. (MHz) | EMISSION LEVEL (dBuV/m) | LIMIT (dBuV/m) | MARGIN (dB) | ANTENNA HEIGHT (m) | TABLE ANGLE (Degree) | RAW VALUE (dBuV) | CORRECTION FACTOR (dB/m) |
| 1 | 2390.00 | 68.7 PK | 74.0 | -5.3 | 1.00 V | 185 | 36.82 | 31.88 |
| 2 | 2390.00 | 51.6 AV | 54.0 | -2.4 | 1.00 V | 185 | 19.72 | 31.88 |
| 3 | *2422.00 | 101.6 PK | | | 1.00 V | 187 | 69.62 | 31.98 |
| 4 | *2422.00 | 91.8 AV | | | 1.00 V | 187 | 59.82 | 31.98 |
| 5 | 4844.00 | 53.5 PK | 74.0 | -20.5 | 1.13 V | 207 | 12.22 | 41.28 |
| 6 | 4844.00 | 40.5 AV | 54.0 | -13.5 | 1.13 V | 207 | -0.78 | 41.28 |
| 7 | 7266.00 | 50.9 PK | 74.0 | -23.1 | 1.17 V | 199 | 5.35 | 45.55 |
| 8 | 7266.00 | 38.2 AV | 54.0 | -15.8 | 1.17 V | 199 | -7.35 | 45.55 |

- REMARKS:**
1. Emission level (dBuV/m) = Raw Value (dBuV) + Correction Factor (dB/m).
 2. Correction Factor (dB/m) = Antenna Factor (dB/m) + Cable Factor (dB).
 3. The other emission levels were very low against the limit.
 4. Margin value = Emission level – Limit value.
 5. “ * “: Fundamental frequency.



A D T

| EUT TEST CONDITION | | MEASUREMENT DETAIL | |
|--------------------------|-----------------|--------------------|---------------------------|
| CHANNEL | Channel 6 | FREQUENCY RANGE | 1 ~ 25GHz |
| INPUT POWER (SYSTEM) | 120Vac, 60 Hz | DETECTOR FUNCTION | Peak (PK) Average (AV) |
| ENVIRONMENTAL CONDITIONS | 25deg. C, 70%RH | TESTED BY | Nelson Teng |

| ANTENNA POLARITY & TEST DISTANCE: HORIZONTAL AT 3 M | | | | | | | | |
|---|-------------|-------------------------|----------------|-------------|--------------------|----------------------|------------------|--------------------------|
| NO. | FREQ. (MHz) | EMISSION LEVEL (dBuV/m) | LIMIT (dBuV/m) | MARGIN (dB) | ANTENNA HEIGHT (m) | TABLE ANGLE (Degree) | RAW VALUE (dBuV) | CORRECTION FACTOR (dB/m) |
| 1 | 2390.00 | 65.3 PK | 74.0 | -8.7 | 1.03 H | 263 | 33.42 | 31.88 |
| 2 | 2390.00 | 49.9 AV | 54.0 | -4.1 | 1.03 H | 263 | 18.02 | 31.88 |
| 3 | *2437.00 | 105.1 PK | | | 1.11 H | 267 | 73.06 | 32.04 |
| 4 | *2437.00 | 95.2 AV | | | 1.11 H | 267 | 63.16 | 32.04 |
| 5 | 2483.50 | 63.1 PK | 74.0 | -10.9 | 1.07 H | 253 | 30.91 | 32.19 |
| 6 | 2483.50 | 47.8 AV | 54.0 | -6.2 | 1.07 H | 253 | 15.61 | 32.19 |
| 7 | 4874.00 | 53.8 PK | 74.0 | -20.2 | 1.27 H | 149 | 12.44 | 41.36 |
| 8 | 4874.00 | 41.7 AV | 54.0 | -12.3 | 1.27 H | 149 | 0.34 | 41.36 |
| 9 | 7311.00 | 53.5 PK | 74.0 | -20.5 | 1.09 H | 212 | 7.83 | 45.67 |
| 10 | 7311.00 | 40.7 AV | 54.0 | -13.3 | 1.09 H | 212 | -4.97 | 45.67 |
| ANTENNA POLARITY & TEST DISTANCE: VERTICAL AT 3 M | | | | | | | | |
| NO. | FREQ. (MHz) | EMISSION LEVEL (dBuV/m) | LIMIT (dBuV/m) | MARGIN (dB) | ANTENNA HEIGHT (m) | TABLE ANGLE (Degree) | RAW VALUE (dBuV) | CORRECTION FACTOR (dB/m) |
| 1 | *2437.00 | 105.6 PK | | | 1.00 V | 188 | 73.56 | 32.04 |
| 2 | *2437.00 | 95.6 AV | | | 1.00 V | 188 | 63.56 | 32.04 |
| 3 | 4874.00 | 55.2 PK | 74.0 | -18.8 | 1.08 V | 214 | 13.84 | 41.36 |
| 4 | 4874.00 | 41.9 AV | 54.0 | -12.1 | 1.08 V | 214 | 0.54 | 41.36 |
| 5 | 7311.00 | 51.3 PK | 74.0 | -22.7 | 1.25 V | 192 | 5.63 | 45.67 |
| 6 | 7311.00 | 38.7 AV | 54.0 | -15.3 | 1.25 V | 192 | -6.97 | 45.67 |

- REMARKS:**
1. Emission level (dBuV/m) = Raw Value (dBuV) + Correction Factor (dB/m).
 2. Correction Factor (dB/m) = Antenna Factor (dB/m) + Cable Factor (dB).
 3. The other emission levels were very low against the limit.
 4. Margin value = Emission level – Limit value.
 5. “ * “: Fundamental frequency.



A D T

| EUT TEST CONDITION | | MEASUREMENT DETAIL | |
|--------------------------|-----------------|--------------------|---------------------------|
| CHANNEL | Channel 9 | FREQUENCY RANGE | 1 ~ 25GHz |
| INPUT POWER (SYSTEM) | 120Vac, 60 Hz | DETECTOR FUNCTION | Peak (PK) Average (AV) |
| ENVIRONMENTAL CONDITIONS | 25deg. C, 70%RH | TESTED BY | Nelson Teng |

ANTENNA POLARITY & TEST DISTANCE: HORIZONTAL AT 3 M

| NO. | FREQ. (MHz) | EMISSION LEVEL (dBuV/m) | LIMIT (dBuV/m) | MARGIN (dB) | ANTENNA HEIGHT (m) | TABLE ANGLE (Degree) | RAW VALUE (dBuV) | CORRECTION FACTOR (dB/m) |
|-----|-------------|-------------------------|----------------|-------------|--------------------|----------------------|------------------|--------------------------|
| 1 | *2452.00 | 101.5 PK | | | 1.05 H | 258 | 69.41 | 32.09 |
| 2 | *2452.00 | 91.6 AV | | | 1.05 H | 258 | 59.51 | 32.09 |
| 3 | 2483.50 | 69.7 PK | 74.0 | -4.3 | 1.02 H | 251 | 37.51 | 32.19 |
| 4 | 2483.50 | 52.7 AV | 54.0 | -1.3 | 1.02 H | 251 | 20.51 | 32.19 |
| 5 | 4904.00 | 52.7 PK | 74.0 | -21.3 | 1.28 H | 141 | 11.26 | 41.44 |
| 6 | 4904.00 | 39.3 AV | 54.0 | -14.7 | 1.28 H | 141 | -2.14 | 41.44 |
| 7 | 7356.00 | 50.9 PK | 74.0 | -23.1 | 1.06 H | 198 | 5.09 | 45.81 |
| 8 | 7356.00 | 38.2 AV | 54.0 | -15.8 | 1.06 H | 198 | -7.61 | 45.81 |

ANTENNA POLARITY & TEST DISTANCE: VERTICAL AT 3 M

| NO. | FREQ. (MHz) | EMISSION LEVEL (dBuV/m) | LIMIT (dBuV/m) | MARGIN (dB) | ANTENNA HEIGHT (m) | TABLE ANGLE (Degree) | RAW VALUE (dBuV) | CORRECTION FACTOR (dB/m) |
|-----|-------------|-------------------------|----------------|-------------|--------------------|----------------------|------------------|--------------------------|
| 1 | *2452.00 | 102.2 PK | | | 1.03 V | 190 | 70.11 | 32.09 |
| 2 | *2452.00 | 92.3 AV | | | 1.03 V | 190 | 60.21 | 32.09 |
| 3 | 2483.50 | 65.6 PK | 74.0 | -8.4 | 1.05 V | 188 | 33.41 | 32.19 |
| 4 | 2483.50 | 52.9 AV | 54.0 | -1.1 | 1.05 V | 188 | 20.71 | 32.19 |
| 5 | 4904.00 | 53.1 PK | 74.0 | -20.9 | 1.12 V | 211 | 11.66 | 41.44 |
| 6 | 4904.00 | 40.2 AV | 54.0 | -13.8 | 1.12 V | 211 | -1.24 | 41.44 |
| 7 | 7356.00 | 51.4 PK | 74.0 | -22.6 | 1.19 V | 193 | 5.59 | 45.81 |
| 8 | 7356.00 | 38.7 AV | 54.0 | -15.3 | 1.19 V | 193 | -7.11 | 45.81 |

- REMARKS:**
1. Emission level (dBuV/m) = Raw Value (dBuV) + Correction Factor (dB/m).
 2. Correction Factor (dB/m) = Antenna Factor (dB/m) + Cable Factor (dB).
 3. The other emission levels were very low against the limit.
 4. Margin value = Emission level – Limit value.
 5. “ * “: Fundamental frequency.



A D T

RESTRICTED BANDEDGE (802.11n (40MHz) MODE,CH3, HORIZONTAL)

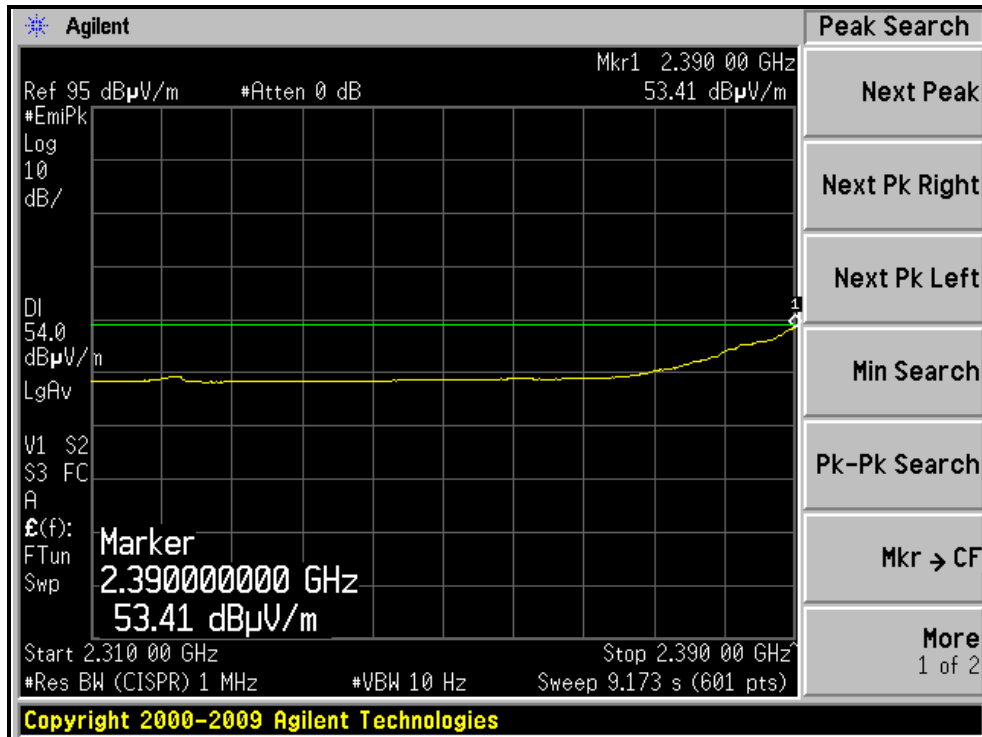
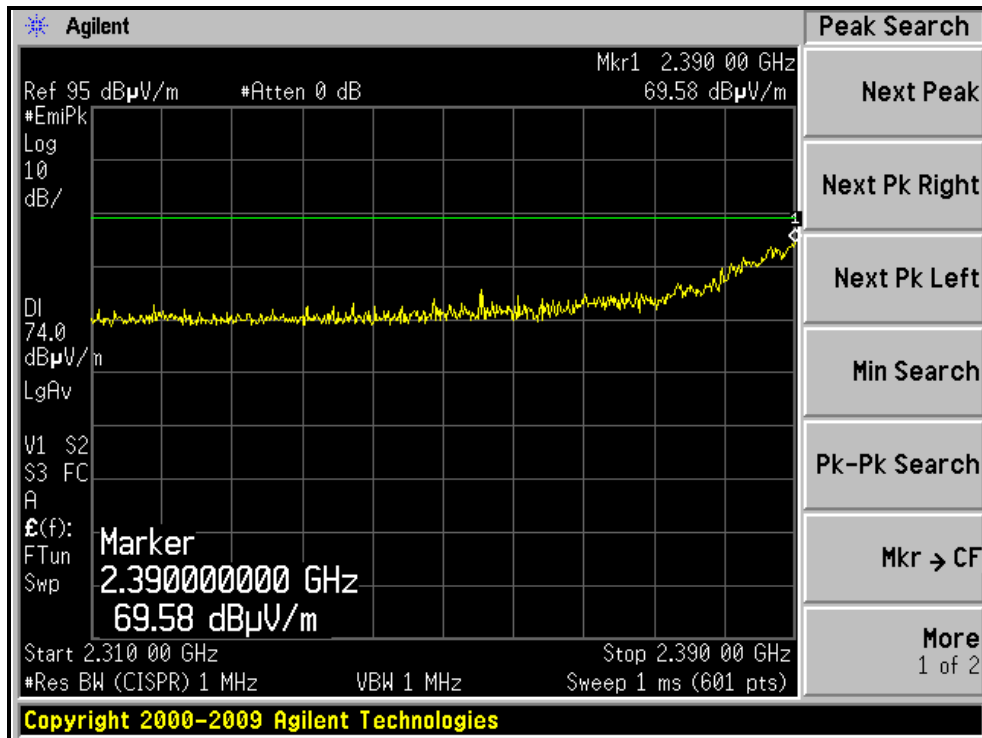



A D T

RESTRICTED BANDEDGE (802.11n (40MHz) MODE,CH3, VERTICAL)

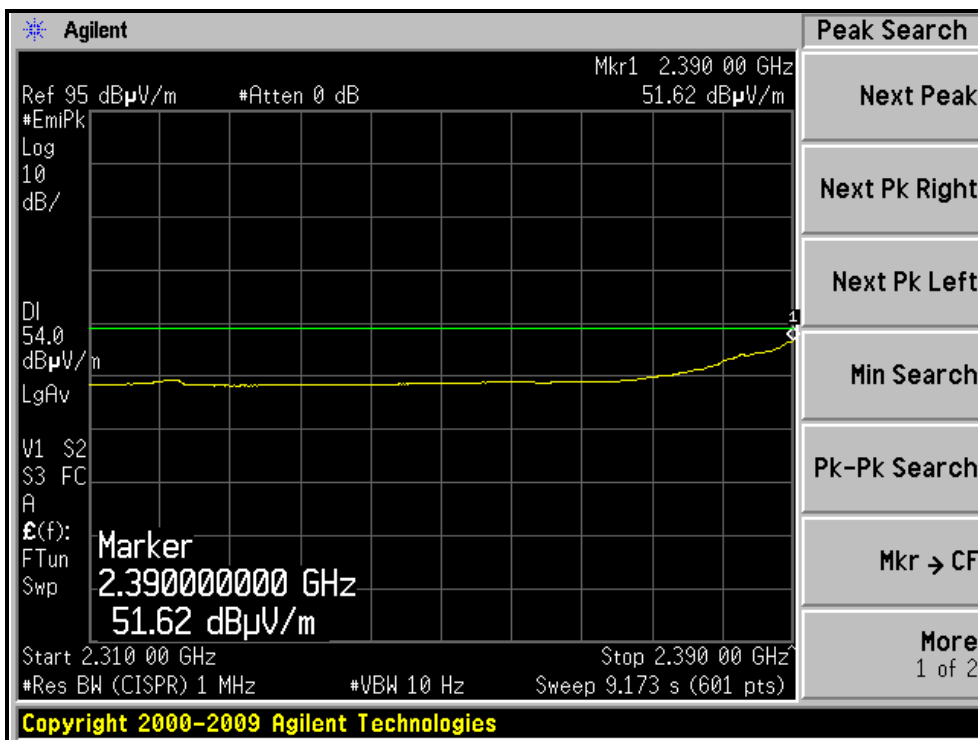
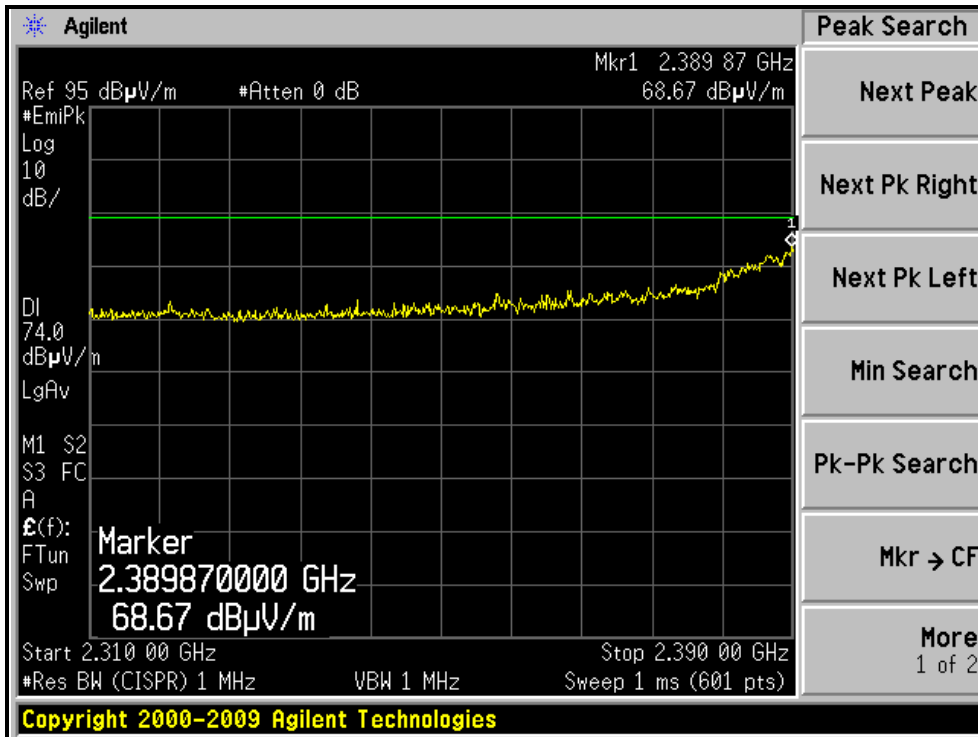



A D T

RESTRICTED BANDEDGE (802.11n (40MHz) MODE,CH9, HORIZONTAL)

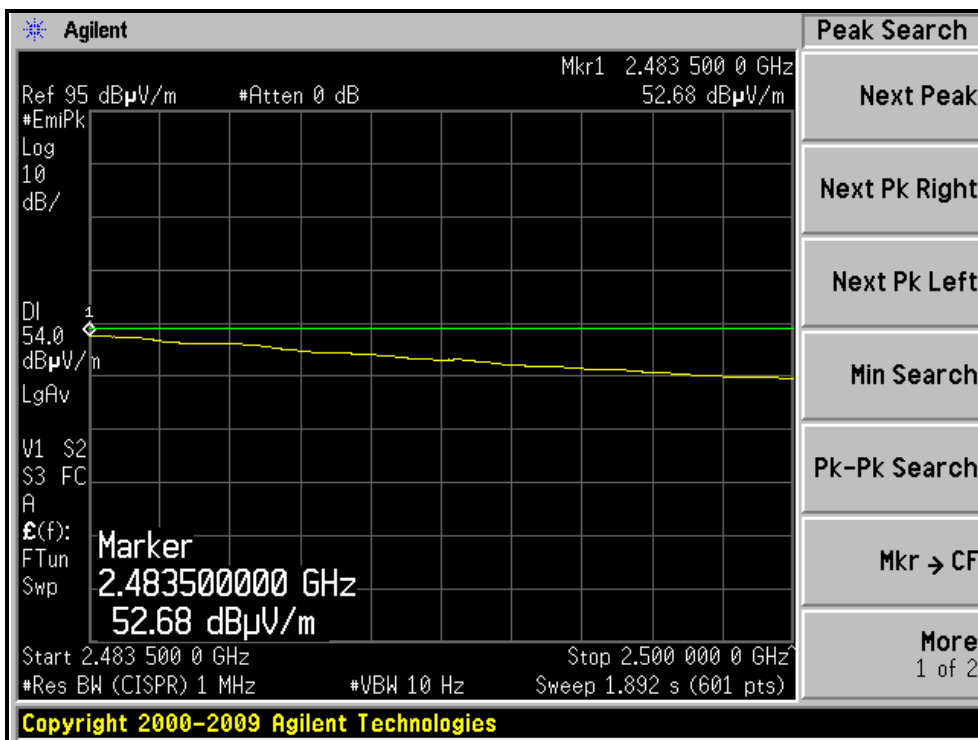
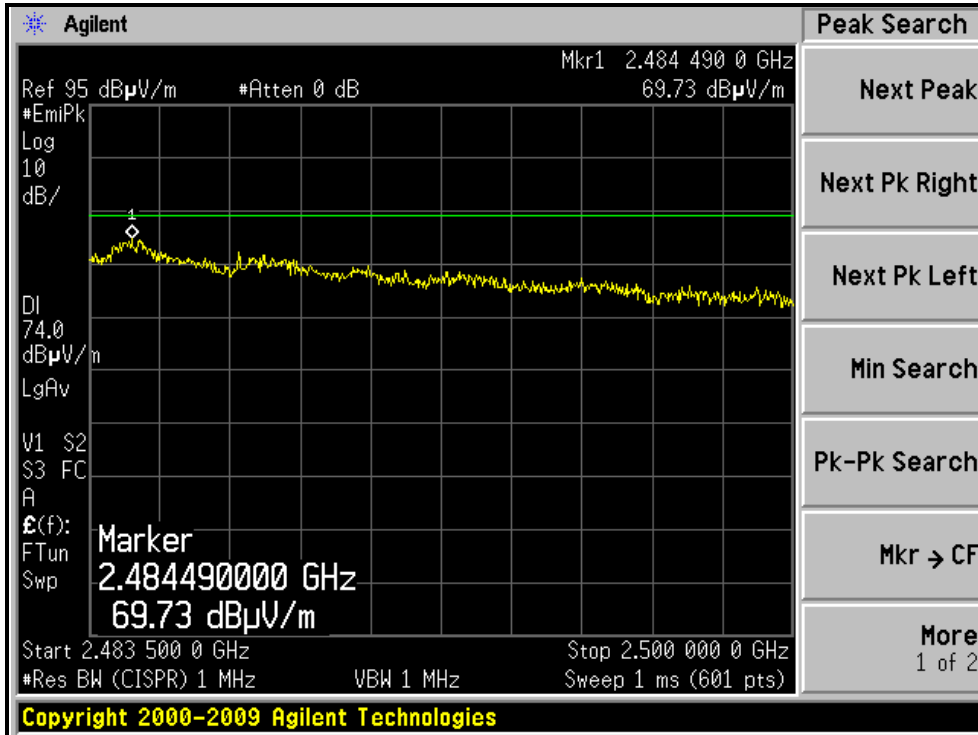



A D T

RESTRICTED BANDEDGE (802.11n (40MHz) MODE,CH9, VERTICAL)

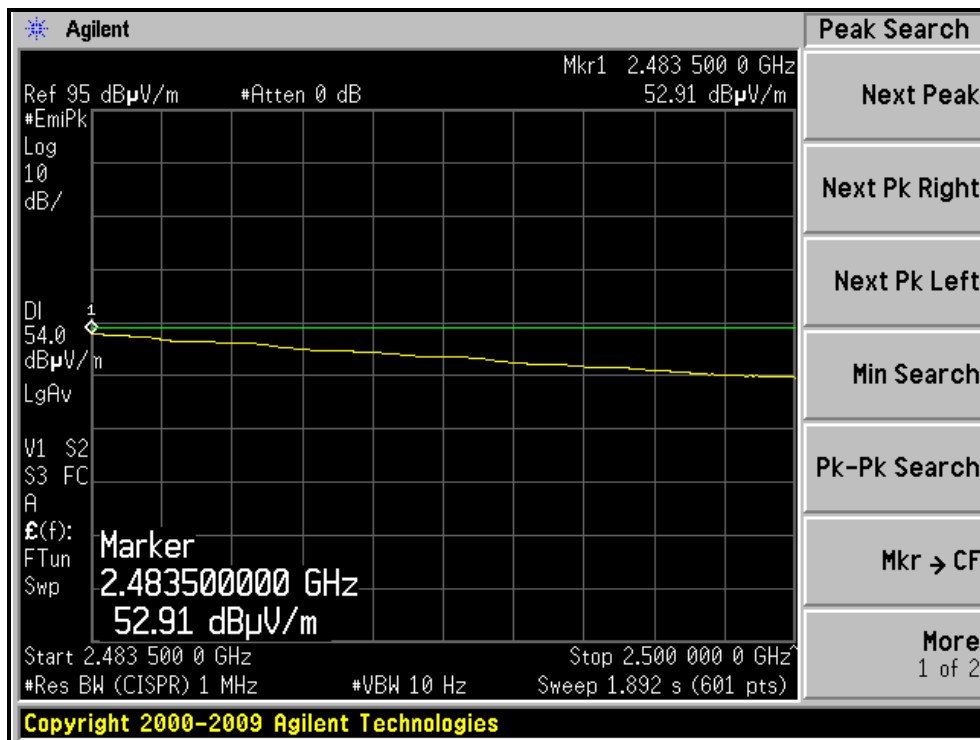
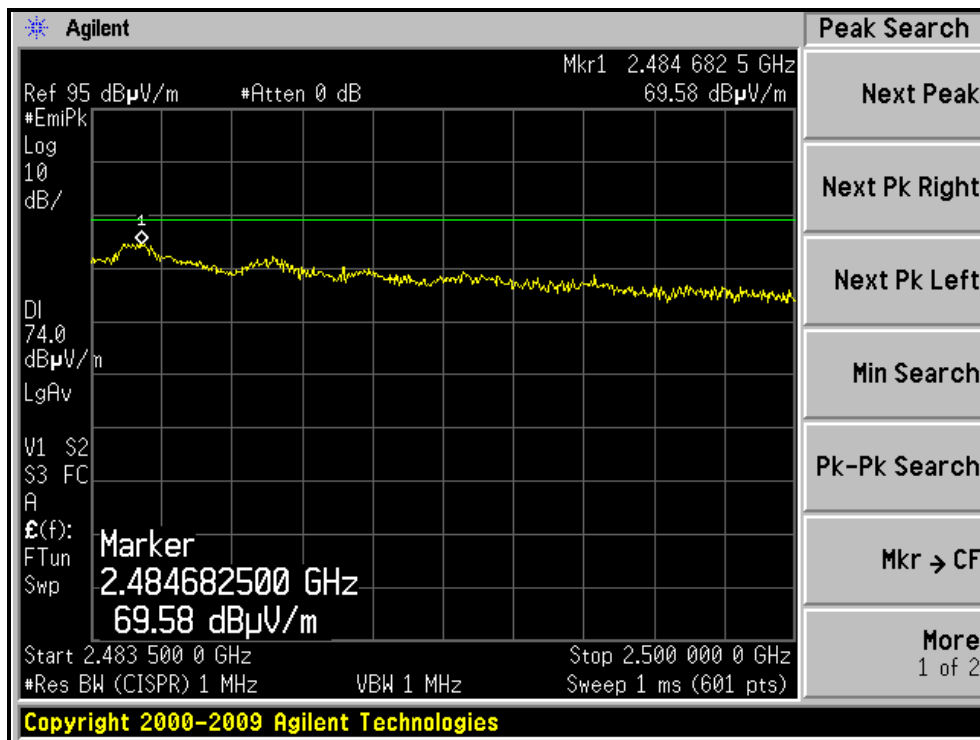

4.3 6dB BANDWIDTH MEASUREMENT

4.3.1 LIMITS OF 6dB BANDWIDTH MEASUREMENT

The minimum of 6dB Bandwidth Measurement is 0.5 MHz.

4.3.2 TEST INSTRUMENTS

Test date: Dec. 07, 2011

| DESCRIPTION & MANUFACTURER | MODEL NO. | SERIAL NO. | CALIBRATED DATE | CALIBRATED UNTIL |
|----------------------------|-----------|------------|-----------------|------------------|
| R&S Spectrum Analyzer | FSP 40 | 100060 | May 11, 2011 | May 10, 2012 |

NOTE: The calibration interval of the above test instruments is 12 months and the calibrations are traceable to NML/ROC and NIST/USA.

4.3.3 TEST PROCEDURE

The transmitter output was connected to the spectrum analyzer through an attenuator. The bandwidth of the fundamental frequency was measured by spectrum analyzer with 100kHz RBW and 300kHz VBW. The 6dB bandwidth is defined as the total spectrum the power of which is higher than peak power minus 6dB.

4.3.4 DEVIATION FROM TEST STANDARD

No deviation

4.3.5 TEST SETUP



4.3.6 EUT OPERATING CONDITIONS

The software provided by client to enable the EUT under transmission condition continuously at lowest, middle and highest channel frequencies individually.



A D T

802.11g OFDM MODULATION:

| CHANNEL | CHANNEL FREQUENCY (MHz) | 6dB BANDWIDTH (MHz) | MINIMUM LIMIT (MHz) | PASS / FAIL |
|---------|-------------------------|---------------------|---------------------|-------------|
| 1 | 2412 | 16.56 | 0.5 | PASS |
| 6 | 2437 | 16.57 | 0.5 | PASS |
| 11 | 2462 | 16.57 | 0.5 | PASS |

CH11

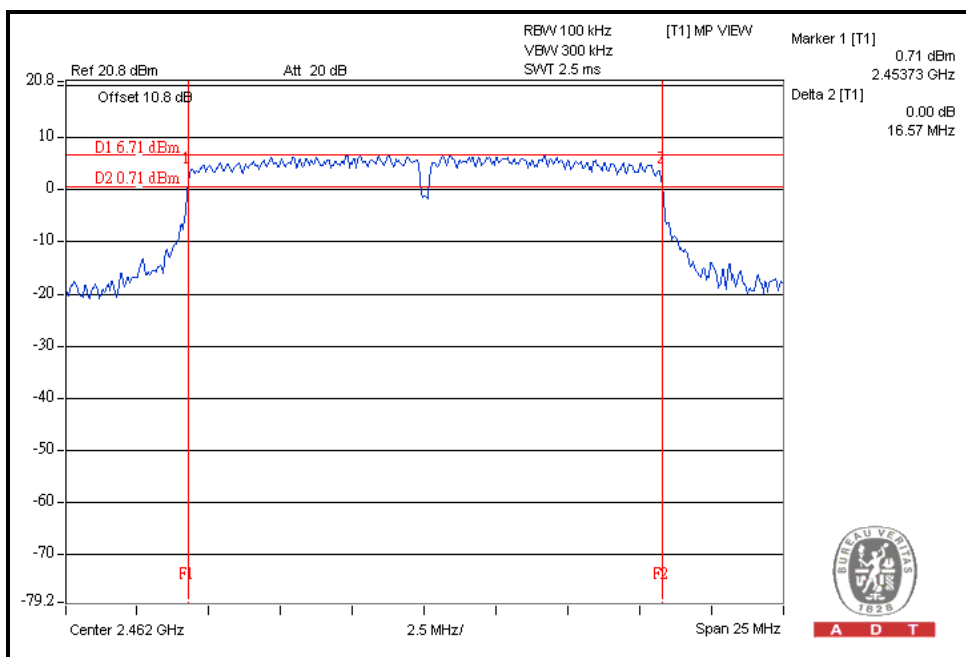



A D T

802.11n (40MHz) OFDM MODULATION:

| CHANNEL | CHANNEL FREQUENCY (MHz) | 6dB BANDWIDTH (MHz) | MINIMUM LIMIT (MHz) | PASS / FAIL |
|---------|-------------------------|---------------------|---------------------|-------------|
| 3 | 2422 | 36.45 | 0.5 | PASS |
| 6 | 2437 | 36.46 | 0.5 | PASS |
| 9 | 2452 | 36.42 | 0.5 | PASS |

CH6

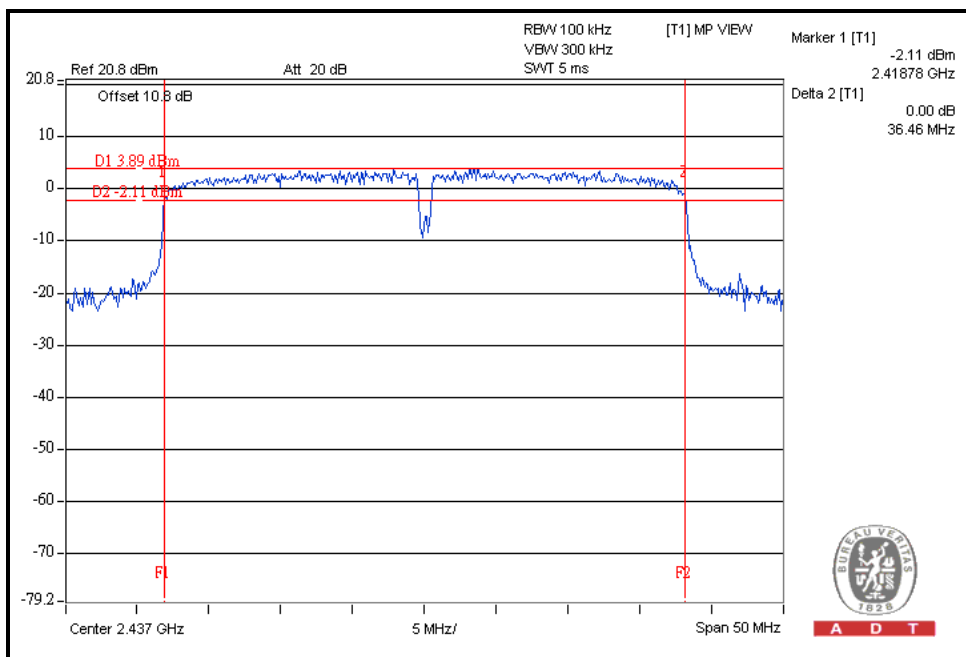

4.4 MAXIMUM PEAK OUTPUT POWER

4.4.1 LIMITS OF MAXIMUM PEAK OUTPUT POWER MEASUREMENT

The Maximum Peak Output Power Measurement is 30dBm.

4.4.2 INSTRUMENTS

Test date: Dec. 07, 2011

| DESCRIPTION & MANUFACTURER | MODEL NO. | SERIAL NO. | CALIBRATED DATE | CALIBRATED UNTIL |
|----------------------------|-----------|------------|-----------------|------------------|
| Peak Power Meter | ML2495A | 0824006 | May 04, 2011 | May 03, 2012 |
| Power Sensor | MA2411B | 0738172 | May 03, 2011 | May 02, 2012 |

NOTE:

The calibration interval of the above test instruments is 12 months and the calibrations are traceable to NML/ROC and NIST/USA.

4.4.3 TEST PROCEDURES

1. The transmitter output was connected to the power meter through an attenuator; the bandwidth of the fundamental frequency was measured with the power meter.
2. Record the power level.

4.4.4 DEVIATION FROM TEST STANDARD

No deviation

4.4.5 TEST SETUP

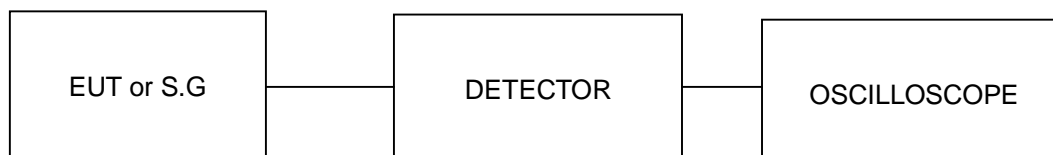

4.4.6 EUT OPERATING CONDITIONS

Same as Item 4.3.6



4.4.7 TEST RESULTS

802.11b DSSS MODULATION:

| CHANNEL | CHANNEL FREQUENCY (MHz) | PEAK POWER OUTPUT (mW) | PEAK POWER OUTPUT (dBm) | PEAK POWER LIMIT (dBm) | PASS / FAIL |
|---------|-------------------------|------------------------|-------------------------|------------------------|-------------|
| 1 | 2412 | 134.9 | 21.3 | 30 | PASS |
| 6 | 2437 | 104.7 | 20.2 | 30 | PASS |
| 11 | 2462 | 141.3 | 21.5 | 30 | PASS |

802.11g OFDM MODULATION:

| CHANNEL | CHANNEL FREQUENCY (MHz) | PEAK POWER OUTPUT (mW) | PEAK POWER OUTPUT (dBm) | PEAK POWER LIMIT (dBm) | PASS / FAIL |
|---------|-------------------------|------------------------|-------------------------|------------------------|-------------|
| 1 | 2412 | 436.5 | 26.4 | 30 | PASS |
| 6 | 2437 | 457.1 | 26.6 | 30 | PASS |
| 11 | 2462 | 478.6 | 26.8 | 30 | PASS |

802.11n (20MHz) OFDM MODULATION:

| CHANNEL | CHANNEL FREQUENCY (MHz) | PEAK POWER OUTPUT (mW) | PEAK POWER OUTPUT (dBm) | PEAK POWER LIMIT (dBm) | PASS / FAIL |
|---------|-------------------------|------------------------|-------------------------|------------------------|-------------|
| 1 | 2412 | 380.2 | 25.8 | 30 | PASS |
| 6 | 2437 | 436.5 | 26.4 | 30 | PASS |
| 11 | 2462 | 478.6 | 26.8 | 30 | PASS |



A D T

802.11n (40MHz) OFDM MODULATION:

| CHANNEL | CHANNEL FREQUENCY (MHz) | PEAK POWER OUTPUT (mW) | PEAK POWER OUTPUT (dBm) | PEAK POWER LIMIT (dBm) | PASS / FAIL |
|---------|-------------------------|------------------------|-------------------------|------------------------|-------------|
| 3 | 2422 | 234.4 | 23.7 | 30 | PASS |
| 6 | 2437 | 446.7 | 26.5 | 30 | PASS |
| 9 | 2452 | 269.2 | 24.3 | 30 | PASS |

4.5 POWER SPECTRAL DENSITY MEASUREMENT

4.5.1 LIMITS OF POWER SPECTRAL DENSITY MEASUREMENT

The Maximum of Power Spectral Density Measurement is 8dBm.

4.5.2 TEST INSTRUMENTS

Test date: Nov. 10, 2011

| DESCRIPTION & MANUFACTURER | MODEL NO. | SERIAL NO. | CALIBRATED DATE | CALIBRATED UNTIL |
|----------------------------|-----------|------------|-----------------|------------------|
| R&S Spectrum Analyzer | FSP 40 | 100060 | May 11, 2011 | May 10, 2012 |

NOTE: The calibration interval of the above test instruments is 12 months and the calibrations are traceable to NML/ROC and NIST/USA.

4.5.3 TEST PROCEDURE

The transmitter output was connected to the spectrum analyzer through an attenuator, the bandwidth of the fundamental frequency was measured with the spectrum analyzer using 3kHz RBW and 30kHz VBW, set sweep time = span/3kHz. The power spectral density was measured and recorded.

The sweep time is allowed to be longer than span/3kHz for a full response of the mixer in the spectrum analyzer.

4.5.4 DEVIATION FROM TEST STANDARD

No deviation

4.5.5 TEST SETUP

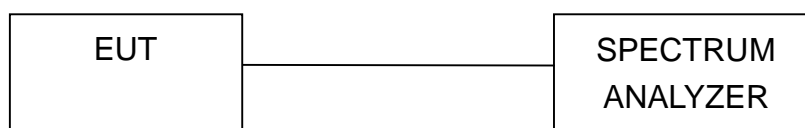

4.5.6 EUT OPERATING CONDITION

Same as Item 4.3.6



A D T

4.5.7 TEST RESULTS

802.11b DSSS MODULATION:

| CHANNEL | CHANNEL FREQUENCY (MHz) | RF POWER LEVEL IN 3kHz BW (dBm) | MAXIMUM LIMIT (dBm) | PASS / FAIL |
|---------|--------------------------|---------------------------------|---------------------|-------------|
| 1 | 2412 | -3.6 | 8 | PASS |
| 6 | 2437 | -3.8 | 8 | PASS |
| 11 | 2462 | -4.7 | 8 | PASS |

CH1

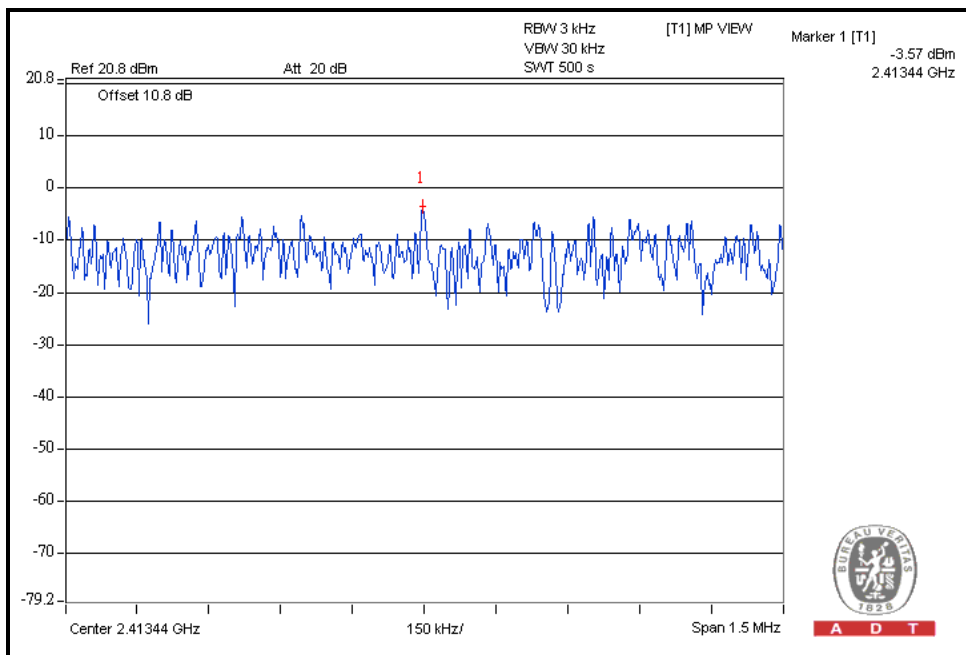



A D T

802.11g OFDM MODULATION:

| CHANNEL | CHANNEL FREQUENCY (MHz) | RF POWER LEVEL IN 3kHz BW (dBm) | MAXIMUM LIMIT (dBm) | PASS / FAIL |
|---------|--------------------------|---------------------------------|---------------------|-------------|
| 1 | 2412 | -7.1 | 8 | PASS |
| 6 | 2437 | -7.0 | 8 | PASS |
| 11 | 2462 | -7.2 | 8 | PASS |

CH6

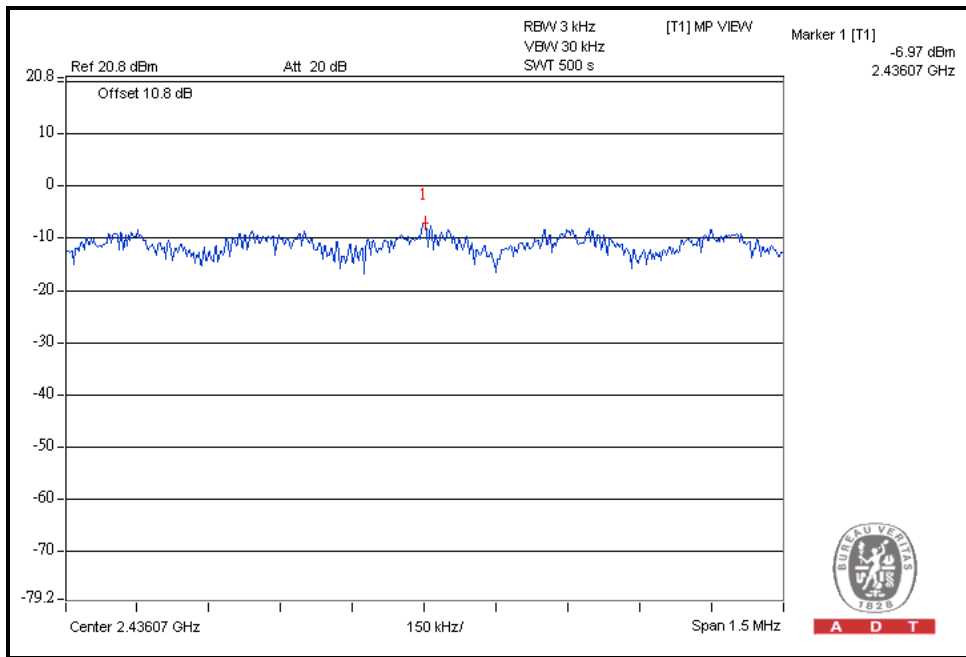



A D T

802.11n (20MHz) OFDM MODULATION:

| CHANNEL | CHANNEL FREQUENCY (MHz) | RF POWER LEVEL IN 3kHz BW (dBm) | MAXIMUM LIMIT (dBm) | PASS / FAIL |
|---------|--------------------------|---------------------------------|---------------------|-------------|
| 1 | 2412 | -8.3 | 8 | PASS |
| 6 | 2437 | -7.5 | 8 | PASS |
| 11 | 2462 | -6.5 | 8 | PASS |

CH11

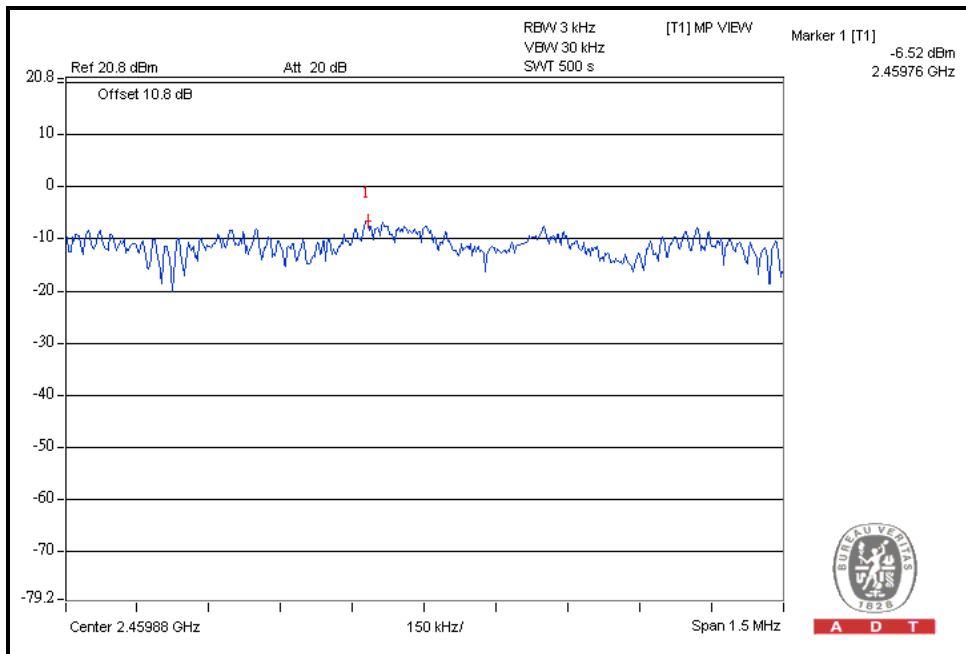



A D T

802.11n (40MHz) OFDM MODULATION:

| CHANNEL | CHANNEL FREQUENCY (MHz) | RF POWER LEVEL IN 3kHz BW (dBm) | MAXIMUM LIMIT (dBm) | PASS / FAIL |
|---------|--------------------------|---------------------------------|---------------------|-------------|
| 3 | 2422 | -12.5 | 8 | PASS |
| 6 | 2437 | -9.0 | 8 | PASS |
| 9 | 2452 | -13.7 | 8 | PASS |

CH6

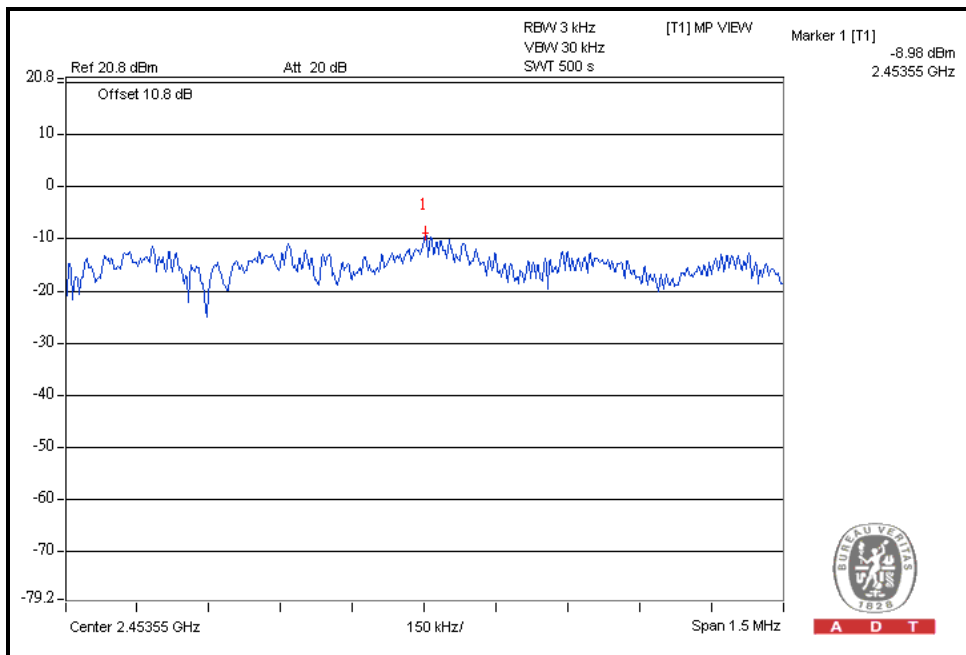

4.6 CONDUCTED OUT-BAND EMISSION MEASUREMENT

4.6.1 LIMITS OF CONDUCTED OUT-BAND EMISSION MEASUREMENT

Below -20dB of the highest emission level of operating band (in 100kHz Resolution Bandwidth).

4.6.2 TEST INSTRUMENTS

Test date: Dec. 07, 2011

| DESCRIPTION & MANUFACTURER | MODEL NO. | SERIAL NO. | CALIBRATED DATE | CALIBRATED UNTIL |
|----------------------------|-----------|------------|-----------------|------------------|
| R&S Spectrum Analyzer | FSP 40 | 100060 | May 11, 2011 | May 10, 2012 |

NOTE: The calibration interval of the above test instruments is 12 months and the calibrations are traceable to NML/ROC and NIST/USA.

4.6.3 TEST PROCEDURE

The transmitter output was connected to the spectrum analyzer via a low loss cable. Set RBW of spectrum analyzer to 100kHz and VBW of spectrum analyzer to 300kHz with suitable frequency span including 100 MHz or 200 MHz bandwidth from band edge. The band edges was measured and recorded.

The spectrum plots (RBW = 100kHz, VBW = 300kHz) are attached on the following pages.

4.6.4 DEVIATION FROM TEST STANDARD

No deviation

4.6.5 EUT OPERATING CONDITION

Same as Item 4.3.6

4.6.6 TEST RESULTS

The spectrum plots are attached on the following images. D1 line indicates the highest level, and D2 line indicates the 20dB offset below D1. It shows compliance with the requirement in part 15.247(d).



A D T

802.11b DSSS MODULATION:

CH1

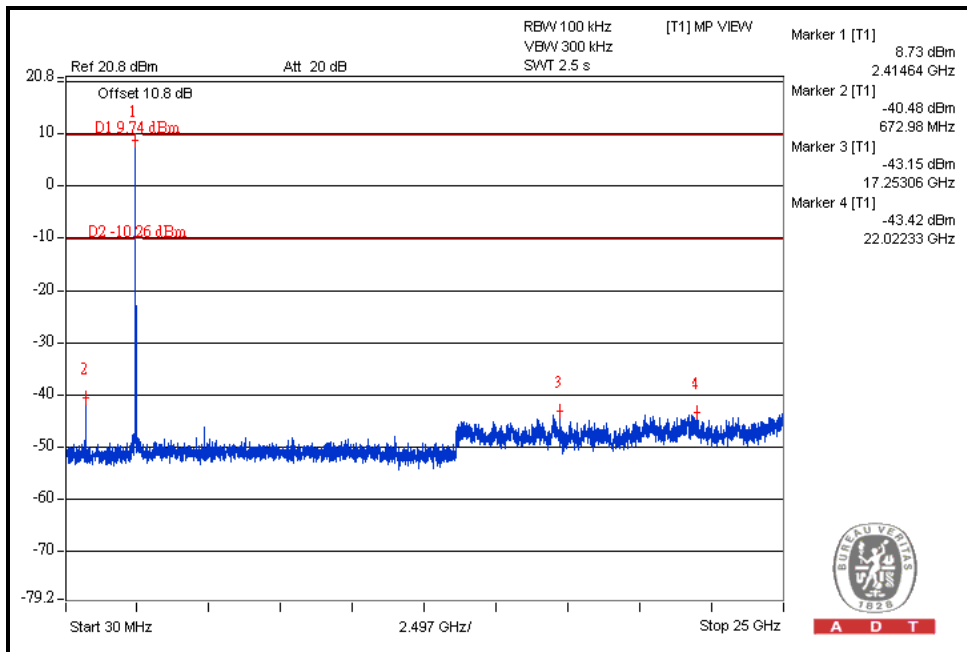
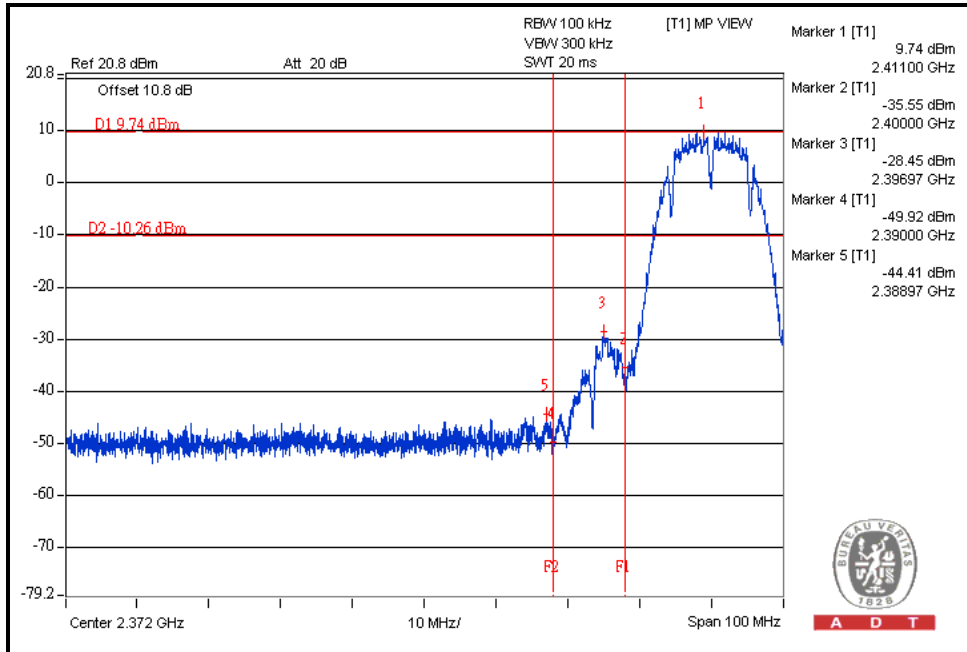



A D T

CH11

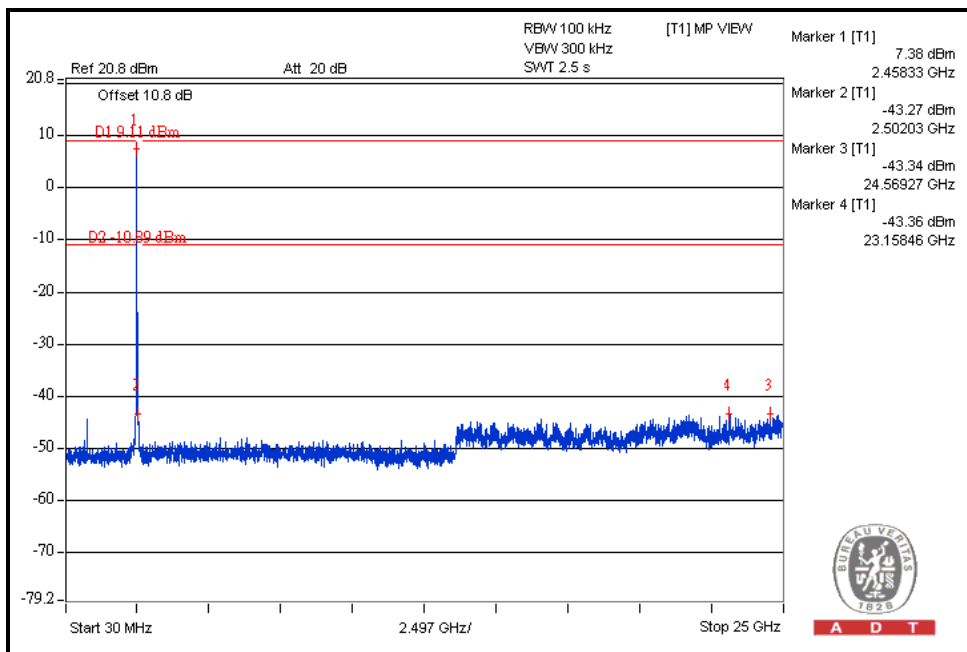
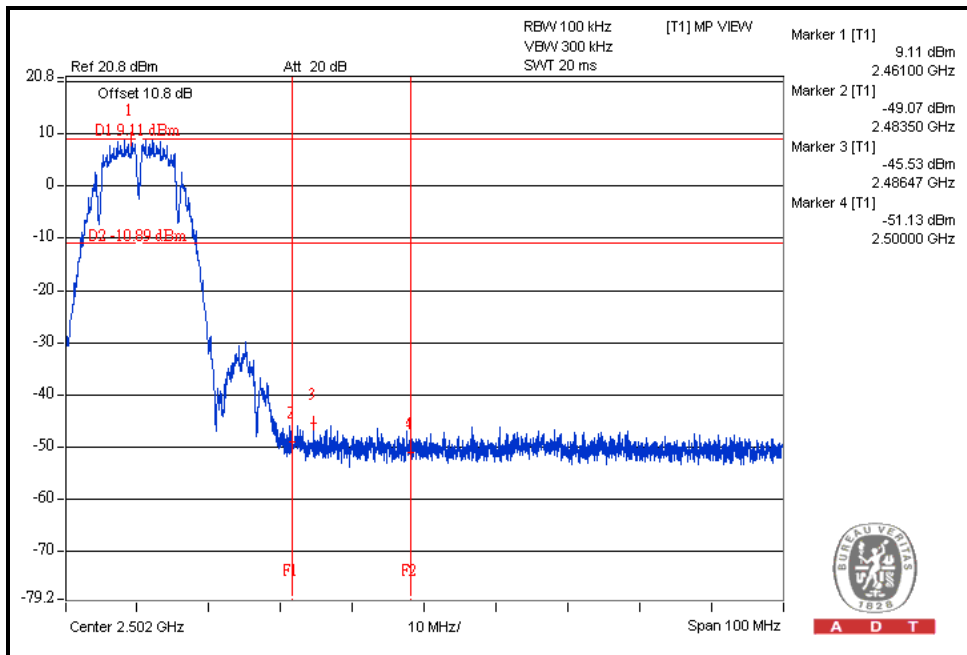



A D T

802.11g OFDM MODULATION:

CH1

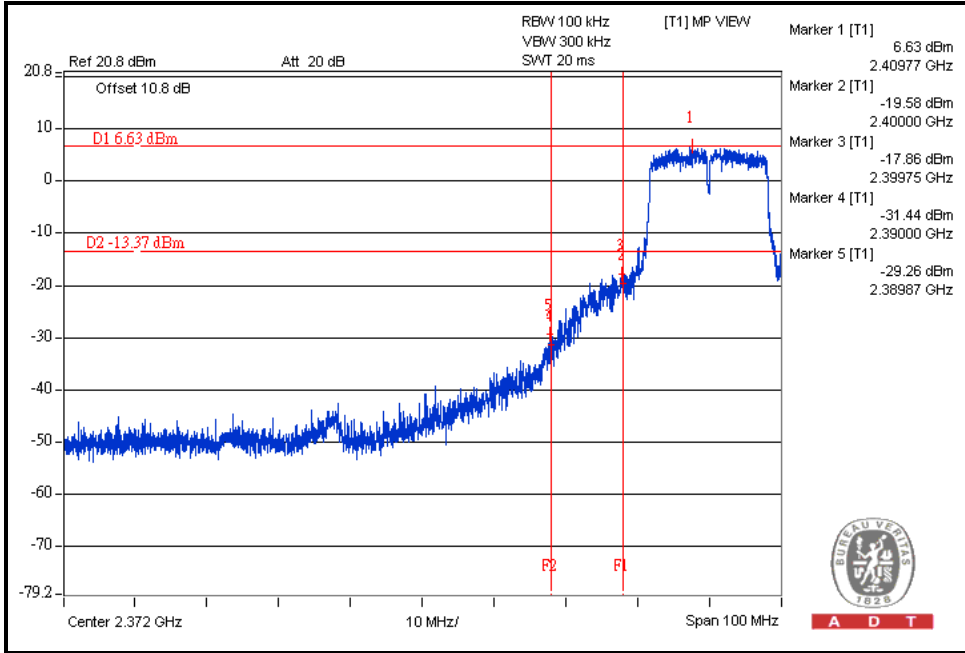

A D T

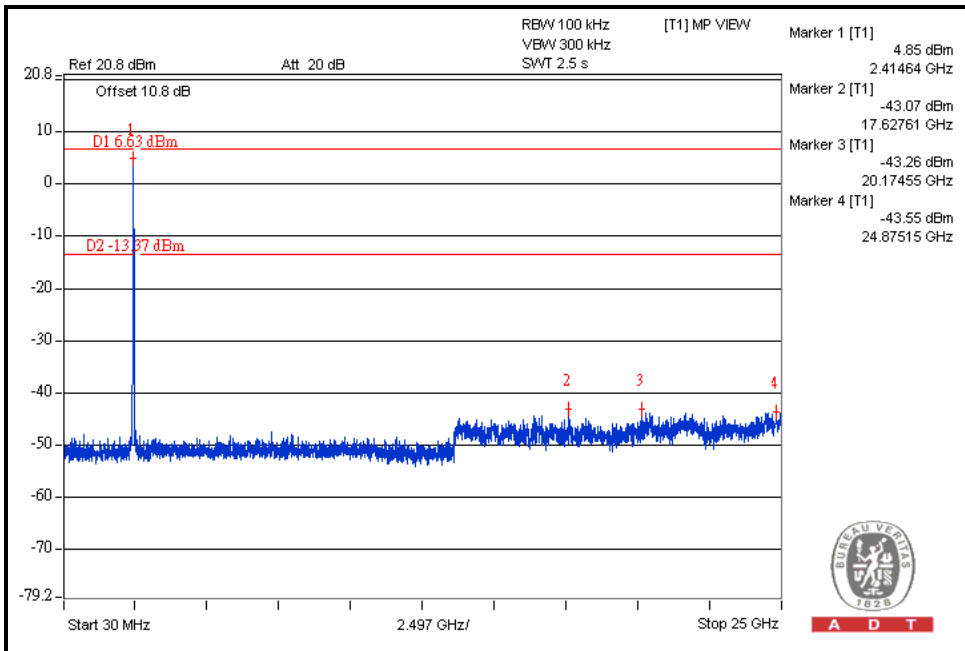

A D T



A D T

CH11

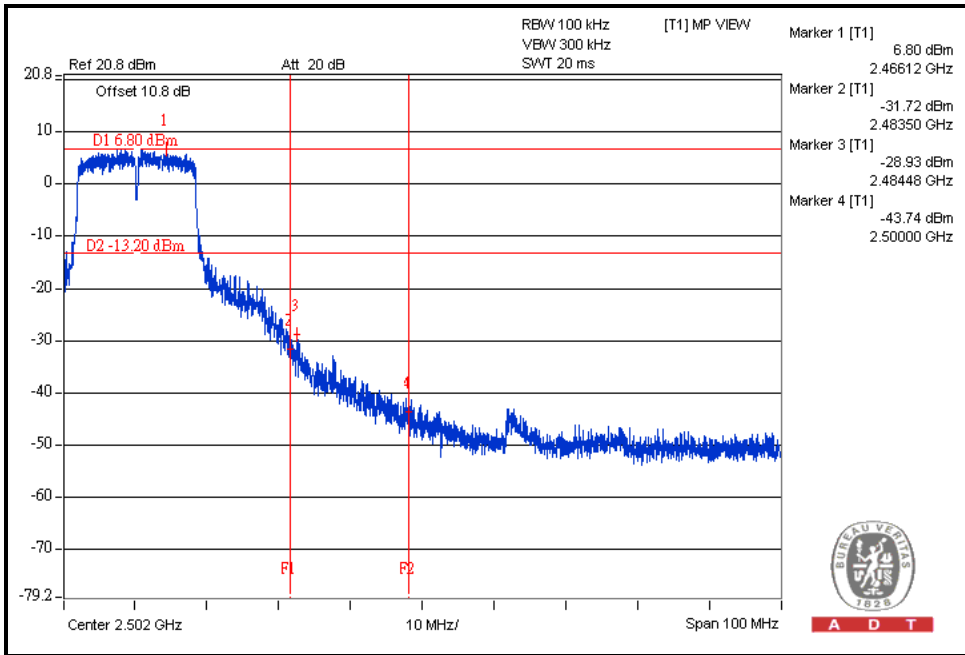

A D T

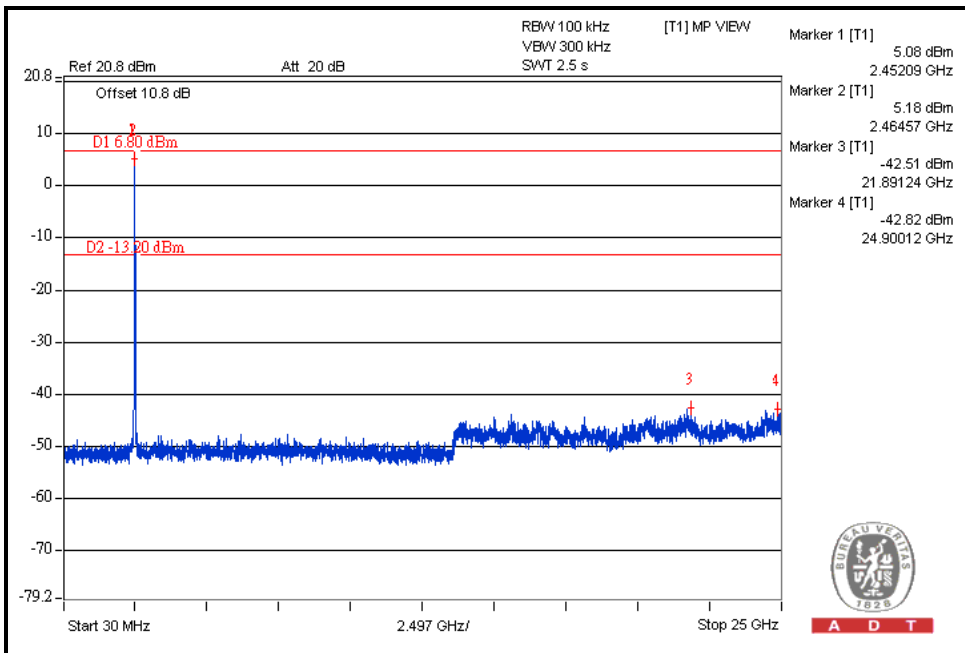

A D T



A D T

802.11n (20MHz) OFDM MODULATION:

CH1

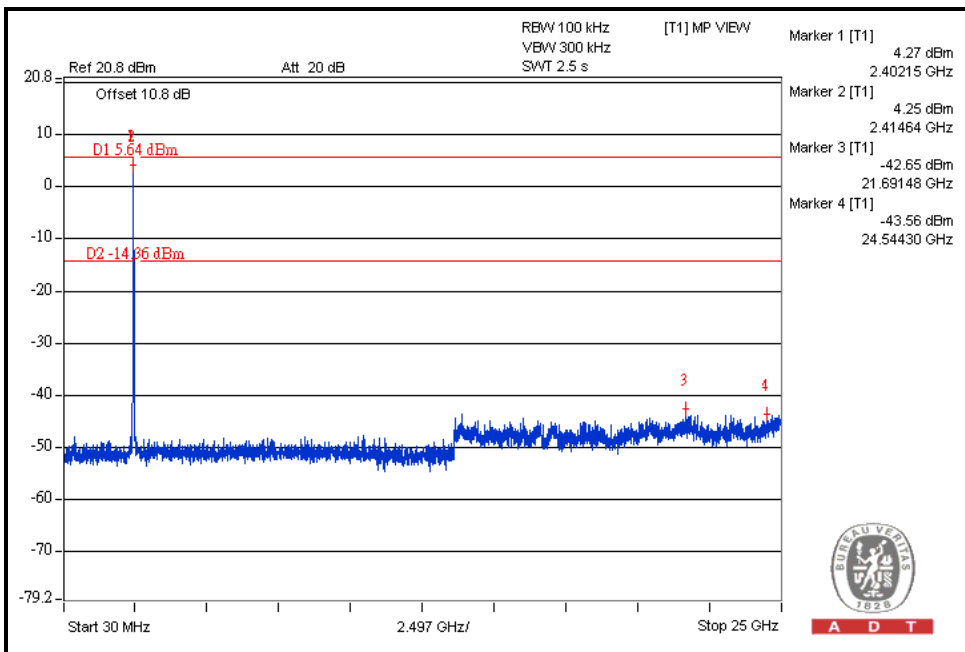
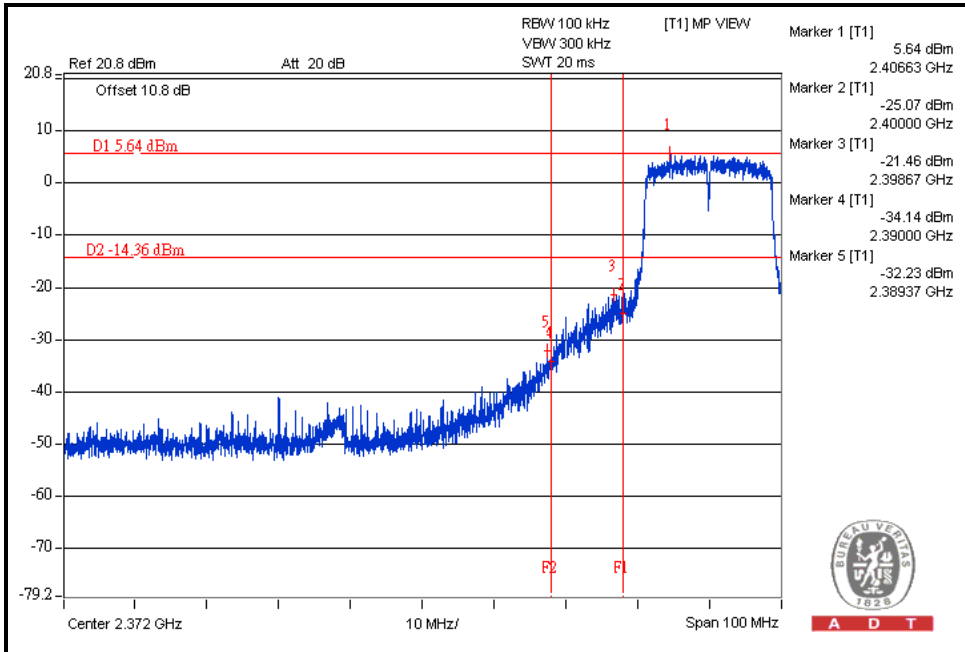



A D T

CH11

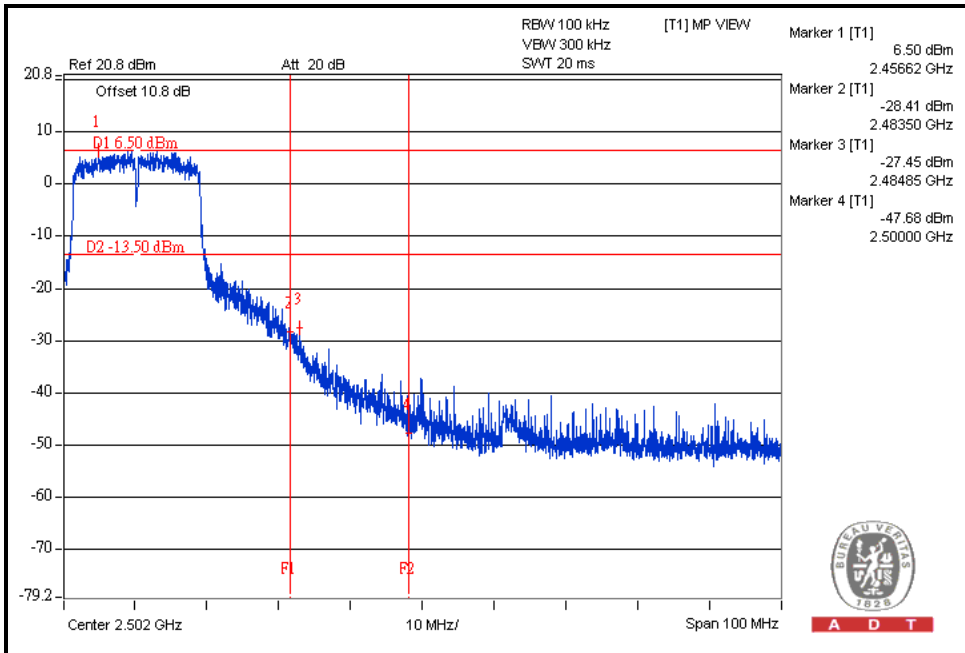

A D T

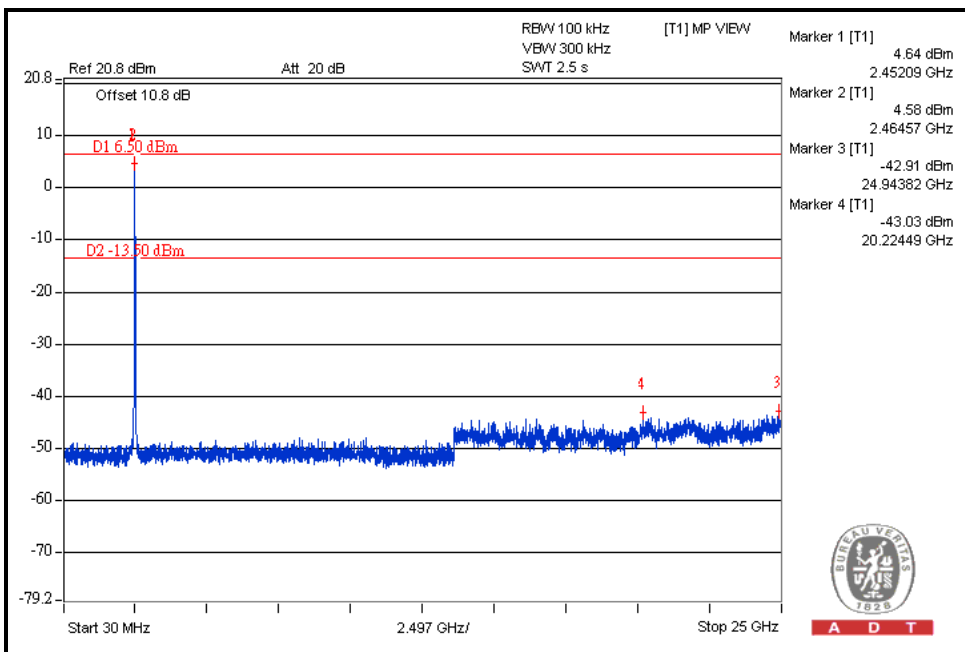

A D T



A D T

802.11n (40MHz) OFDM MODULATION:

CH3

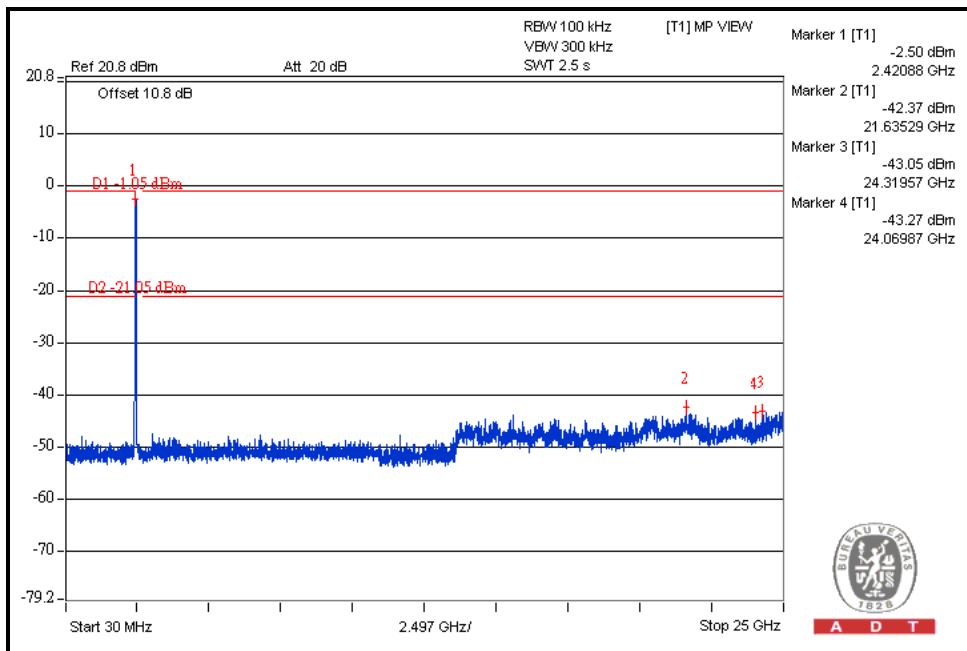
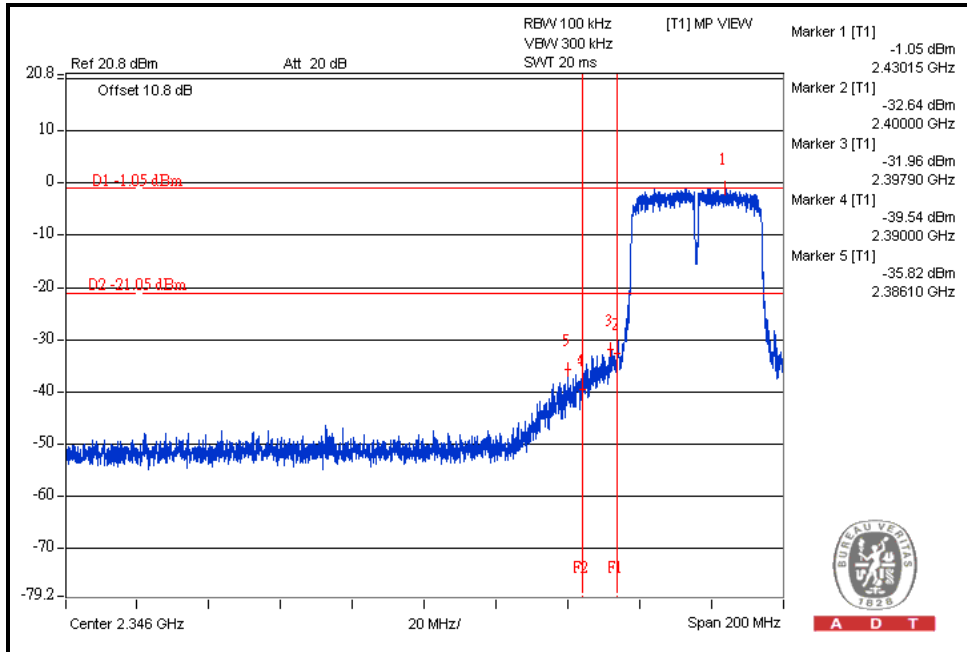



A D T

CH9

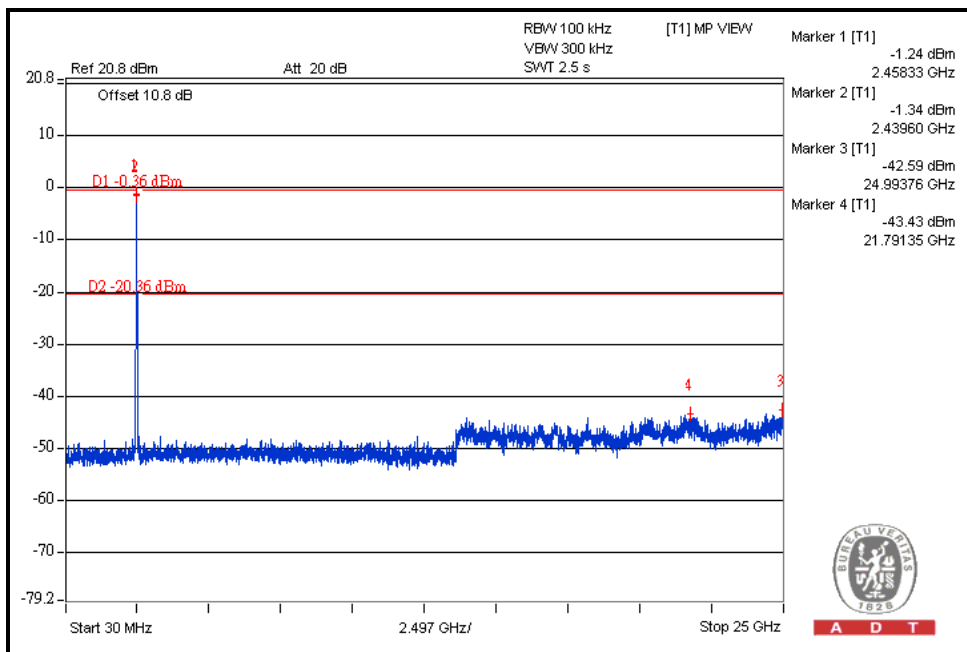
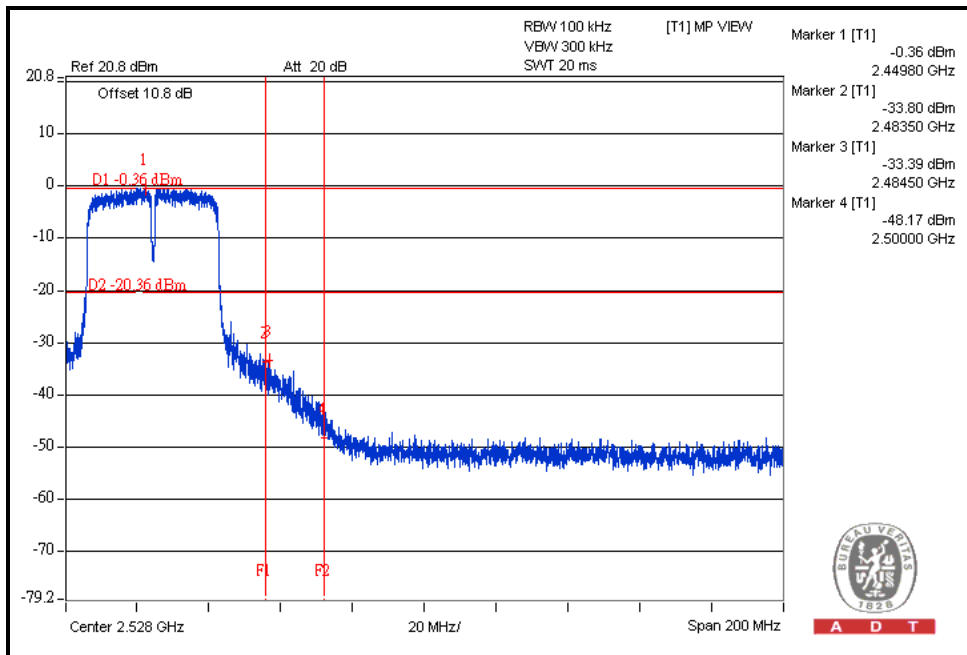



5. INFORMATION ON THE TESTING LABORATORIES

We, Bureau Veritas Consumer Products Services (H.K.) Ltd., Taoyuan Branch, were founded in 1988 to provide our best service in EMC, Radio, Telecom and Safety consultation. Our laboratories are accredited and approved according to ISO/IEC 17025.

Copies of accreditation and authorization certificates of our laboratories obtained from approval agencies can be downloaded from our web site:

www.adt.com.tw/index.5.phtml.

If you have any comments, please feel free to contact us at the following:

Linko EMC/RF Lab:

Tel: 886-2-26052180

Fax: 886-2-26052943

Hsin Chu EMC/RF Lab:

Tel: 886-3-5935343

Fax: 886-3-5935342

Hwa Ya EMC/RF/Safety/Telecom Lab:

Tel: 886-3-3183232

Fax: 886-3-3185050

Email: service.adt@tw.bureauveritas.com

Web Site: www.adt.com.tw

The address and road map of all our labs can be found in our web site also.



A D T

6.APPENDIX A - MODIFICATIONS RECORDERS FOR ENGINEERING CHANGES TO THE EUT BY THE LAB

No modifications were made to the EUT by the lab during the test.

--- END ---