



A D T

FCC TEST REPORT (15.407)

REPORT NO.: RF120210E01-1 R1

MODEL NO.: D2F

FCC ID: RRK-D2F

RECEIVED: Feb. 10, 2012

TESTED: Feb. 15 to 17, 2012

ISSUED: Apr. 13, 2012

APPLICANT: Alpha Networks Inc.

ADDRESS: No.8 Li-shing 7th Rd., Science-based
Industrial Park, Hsinchu, Taiwan, R.O.C.

ISSUED BY: Bureau Veritas Consumer Products Services
(H.K.) Ltd., Taoyuan Branch Hsin Chu Laboratory

LAB ADDRESS : No. 81-1, Lu Liao Keng, 9th Ling, Wu Lung Tsuen,
Chiung Lin Hsiang, Hsin Chu Hsien 307, Taiwan,
R.O.C.

TEST LOCATION (1): No. 81-1, Lu Liao Keng, 9th Ling, Wu Lung Tsuen,
Chiung Lin Hsiang, Hsin Chu Hsien 307, Taiwan,
R.O.C.

TEST LOCATION (2): No. 49, Ln. 206, Wende Rd., Shangshan Tsuen,
Chiung Lin Hsiang, Hsin Chu Hsien 307, Taiwan,
R.O.C.

This test report consists of 57 pages in total. It may be duplicated completely for legal use with the approval of the applicant. It should not be reproduced except in full, without the written approval of our laboratory. The client should not use it to claim product certification, approval, or endorsement by TAF or any government agencies. The test results in the report only apply to the tested sample.





A D T

Table of Contents

RELEASE CONTROL RECORD	4
1. CERTIFICATION	5
2. SUMMARY OF TEST RESULTS	6
2.1 MEASUREMENT UNCERTAINTY	7
3. GENERAL INFORMATION	8
3.1 GENERAL DESCRIPTION OF EUT	8
3.2 DESCRIPTION OF TEST MODES	11
3.2.1 TEST MODE APPLICABILITY AND TESTED CHANNEL DETAIL	12
3.3 GENERAL DESCRIPTION OF APPLIED STANDARDS	14
3.4 DUTY CYCLE OF TEST SIGNAL	14
3.5 DESCRIPTION OF SUPPORT UNITS	15
3.6 CONFIGURATION OF SYSTEM UNDER TEST	16
4. TEST TYPES AND RESULTS	17
4.1 CONDUCTED EMISSION MEASUREMENT	17
4.1.1 LIMITS OF CONDUCTED EMISSION MEASUREMENT	17
4.1.2 TEST INSTRUMENTS	17
4.1.3 TEST PROCEDURES	18
4.1.4 DEVIATION FROM TEST STANDARD	18
4.1.5 TEST SETUP	19
4.1.6 EUT OPERATING CONDITIONS	19
4.1.7 TEST RESULTS	20
4.2 RADIATED EMISSION MEASUREMENT	22
4.2.1 LIMITS OF RADIATED EMISSION MEASUREMENT	22
4.2.2 LIMITS OF UNWANTED EMISSION OUT OF THE RESTRICTED BANDS	23
4.2.3 TEST INSTRUMENTS	24
4.2.4 TEST PROCEDURES	26
4.2.5 DEVIATION FROM TEST STANDARD	26
4.2.6 TEST SETUP	27
4.2.7 EUT OPERATING CONDITION	27
4.2.8 TEST RESULTS	28
4.3 TRANSMIT POWER MEASUREMENT	37
4.3.1 LIMITS OF TRANSMIT POWER MEASUREMENT	37
4.3.2 TEST INSTRUMENTS	37
4.3.3 TEST PROCEDURE	38
4.3.4 DEVIATION FROM TEST STANDARD	38
4.3.5 TEST SETUP	39
4.3.6 EUT OPERATING CONDITIONS	39
4.3.7 TEST RESULTS	40



A D T

4.4	PEAK POWER SPECTRAL DENSITY MEASUREMENT	42
4.4.1	LIMITS OF PEAK POWER SPECTRAL DENSITY MEASUREMENT	42
4.4.2	TEST INSTRUMENTS.....	42
4.4.3	TEST PROCEDURES	42
4.4.4	DEVIATION FROM TEST STANDARD	42
4.4.5	TEST SETUP	43
4.4.6	EUT OPERATING CONDITIONS	43
4.4.7	TEST RESULTS	44
4.5	PEAK POWER EXCURSION MEASUREMENT	45
4.5.1	LIMITS OF PEAK POWER EXCURSION MEASUREMENT	45
4.5.2	TEST INSTRUMENTS.....	45
4.5.3	TEST PROCEDURE.....	45
4.5.4	DEVIATION FROM TEST STANDARD	45
4.5.5	TEST SETUP	45
4.5.6	EUT OPERATING CONDITIONS	45
4.5.7	TEST RESULTS	46
4.6	FREQUENCY STABILITY.....	52
4.6.1	LIMITS OF FREQUENCY STABILITY MEASUREMENT	52
4.6.2	TEST INSTRUMENTS.....	52
4.6.3	TEST PROCEDURE.....	52
4.6.4	DEVIATION FROM TEST STANDARD	53
4.6.5	TEST SETUP	53
4.6.6	EUT OPERATING CONDITION	53
4.6.7	TEST RESULTS	54
5.	PHOTOGRAPHS OF THE TEST CONFIGURATION.....	55
6.	INFORMATION ON THE TESTING LABORATORIES	56
7.	APPENDIX A - MODIFICATIONS RECORDERS FOR ENGINEERING CHANGES TO THE EUT BY THE LAB.....	57



A D T

RELEASE CONTROL RECORD

ISSUE NO.	REASON FOR CHANGE	DATE ISSUED
RF120210E01-1	Original release	Apr. 10, 2012
RF120210E01-1 R1	Modified Antenna Connector type of the EUT	Apr. 13, 2012



A D T

1. CERTIFICATION

PRODUCT: MY NET N600
BRAND NAME: WD
MODEL NO.: D2F
TEST SAMPLE: MASS-PRODUCTION
APPLICANT: Alpha Networks Inc.
TESTED: Feb. 15 to 17, 2012
STANDARDS: **FCC Part 15, Subpart E (Section 15.407)**
ANSI C63.10-2009

The above equipment (Model: D2F) has been tested by **Bureau Veritas Consumer Products Services (H.K.) Ltd., Taoyuan Branch**, and found compliance with the requirement of the above standards. The test record, data evaluation & Equipment Under Test (EUT) configurations represented herein are true and accurate accounts of the measurements of the sample's EMC characteristics under the conditions specified in this report.

PREPARED BY :  , **DATE:** Apr. 13, 2012
(Lori Chung, Specialist)

APPROVED BY :  , **DATE:** Apr. 13, 2012
(May Chen, Deputy Manager)

2. SUMMARY OF TEST RESULTS

The EUT has been tested according to the following specifications:

For 5GHz, 5180~5240MHz

APPLIED STANDARD: FCC PART 15, SUBPART E (SECTION 15.407)			
STANDARD SECTION	TEST TYPE	RESULT	REMARK
15.407(b)(6)	AC Power Conducted Emission	PASS	Meet the requirement of limit. Minimum passing margin is -20.15dB at 0.39666MHz
15.407(b/1/2/3)(b)(6)	Spurious Emissions	PASS	Meet the requirement of limit. Minimum passing margin is -0.5dB at 5440.00MHz.
15.407(a/1/2)	Transmit Power	PASS	Meet the requirement of limit.
15.407(a)(6)	Peak Power Excursion	PASS	Meet the requirement of limit.
15.407(a/1/2)	Peak Power Spectral Density	PASS	Meet the requirement of limit.
15.407(g)	Frequency Stability	PASS	Meet the requirement of limit.
15.203	Antenna Requirement	PASS	Antenna connector is MHF not a standard connector.

NOTE:

1. The EUT was operating in 2400 ~ 2483.5MHz, 5.15~5.25GHz and 5.725~5.850GHz frequencies band. This report was recorded the RF parameters including 5.15~5.25GHz. For the 2400 ~ 2483.5MHz and 5.725~5.850GHz RF parameters was recorded in another test report.



A D T

2.1 MEASUREMENT UNCERTAINTY

Where relevant, the following measurement uncertainty levels have been estimated for tests performed on the EUT as specified in CISPR 16-4-2:

This uncertainty represents an expanded uncertainty expressed at approximately the 95% confidence level using a coverage factor of $k=2$.

Measurement	Value
Conducted emissions	2.45 dB
Radiated emissions (30MHz-1GHz)	3.81 dB
Radiated emissions (1GHz -18GHz)	2.19 dB
Radiated emissions (18GHz -40GHz)	2.56 dB



A D T

3. GENERAL INFORMATION

3.1 GENERAL DESCRIPTION OF EUT

PRODUCT	MY NET N600
MODEL NO.	D2F
FCC ID	RRK-D2F
POWER SUPPLY	DC 12V from external power adapter
MODULATION TYPE	CCK, DQPSK, DBPSK for DSSS 64QAM, 16QAM, QPSK, BPSK for OFDM
MODULATION TECHNOLOGY	DSSS, OFDM
TRANSFER RATE	802.11b: Up to 11Mbps 802.11a/g: Up to 54Mbps 802.11n (20MHz, 800ns GI): Up to 130Mbps 802.11n (20MHz, 400ns GI): Up to 144.444Mbps 802.11n (40MHz, 800ns GI): Up to 270Mbps 802.11n (40MHz, 400ns GI): Up to 300Mbps
OPERATING FREQUENCY	For 15.407 802.11a: 5.18 ~ 5.24GHz For 15.247 802.11b/g: 2.412 ~ 2.462GHz 802.11a: 5.745 ~ 5.825GHz
NUMBER OF CHANNEL	For 15.407 4 for 802.11a, 802.11n (20MHz) 2 for 802.11n (40MHz) For 15.247 (2.4GHz) 11 for 802.11b, 802.11g, 802.11n (20MHz) 7 for 802.11n (40MHz) For 15.247 (5GHz) 5 for 802.11a, 802.11n (20MHz) 2 for 802.11n (40MHz)



A D T

MAXIMUM OUTPUT POWER	<p>For 15.407 802.11a: 28.3mW 802.11n (20MHz): 46.0mW 802.11n (40MHz): 48.0mW</p> <p>For 15.247 (2.4GHz) 802.11b: 360.0mW 802.11g: 485.4mW 802.11n (20MHz): 485.4mW 802.11n (40MHz): 442.6mW</p> <p>For 15.247 (5GHz) 802.11a: 485.6mW 802.11n (20MHz): 789.7mW 802.11n (40MHz): 762.2mW</p>
ANTENNA TYPE	Please see NOTE
DATA CABLE	NA
I/O PORTS	Refer to user's manual
ASSOCIATED DEVICES	Adapter x 1

NOTE:

1. The antennas provided to the EUT, please refer to the following table:

For 2.4GHz					
Transmitter Circuit	Brand	Model	Peak Gain (dBi)	Antenna Type	Connector Type
Chain (0)	WHA YU GROUP	C037-511171-A (SSR-14424)	3	PCB	NA
Chain (1)	WHA YU GROUP	C037-511170-A (SSR-2011130)	3	PCB	NA
For 5GHz					
Transmitter Circuit	Brand	Model	Peak Gain (dBi)	Antenna Type	Connector Type
Chain (0)	WHA YU GROUP	C037-511172-A (SSR-2011133)	5	PCB	MHF
Chain (1)	WHA YU GROUP	C037-511176-A (SSR-14470)	5	PCB	MHF



A D T

2. The EUT must be supplied with a power adapter as following table:

Brand	Model No.	Spec.
APD	WA-24E12FU	Input: 100-240V, 50-60Hz, 0.65A Max Output: 12V, 2A DC output cable (1.8m, unshielded, with one core)

3. The EUT incorporates a MIMO function. Physically, the EUT provides two completed transmitters and two receivers.

MODULATION MODE	TX/Rx FUNCTION
802.11b	2Tx/2Rx
802.11g	2Tx/2Rx
802.11a	2Tx/2Rx
802.11n (20MHz)	2Tx/2Rx
802.11n (40MHz)	2Tx/2Rx

4. Spurious emission of the simultaneous operation (2.4GHz & 5GHz) has been evaluated and no non-compliance was found.
5. The EUT is 2 * 2 spatial MIMO (2Tx & 2Rx) without beam forming function.
6. The EUT incorporates CDD function with 802.11a, 802.11b, 802.11g.
7. When the EUT operating in 802.11n, the software operation, which is defined by manufacturer, MCS (Modulation and Coding Schemes) from 0 to 15.
8. The above EUT information was declared by the manufacturer and for more detailed features description, please refer to the manufacturer's specifications or User's Manual.



A D T

3.2 DESCRIPTION OF TEST MODES

Operated in 5150MHz ~ 5250MHz bands:

Four channels are provided for 802.11a and 802.11n (20MHz):

CHANNEL	FREQUENCY
36	5180 MHz
40	5200 MHz
44	5220 MHz
48	5240 MHz

Two channels are provided for 802.11n (40MHz):

CHANNEL	FREQUENCY
38	5190 MHz
46	5230 MHz

3.2.1 TEST MODE APPLICABILITY AND TESTED CHANNEL DETAIL

EUT CONFIGURE MODE	APPLICABLE TO					DESCRIPTION
	PLC	RE < 1G	RE ≥ 1G	APCM	OB	
-	√	√	√	√	√	-

Where **PLC**: Power Line Conducted Emission **RE < 1G**: Radiated Emission below 1GHz
RE ≥ 1G: Radiated Emission above 1GHz **APCM**: Antenna Port Conducted Measurement
OB: Conducted Out-Band Emission Measurement

POWER LINE CONDUCTED EMISSION TEST:

- Pre-Scan has been conducted to determine the worst-case mode from all possible combinations between available modulations, data rates and antenna ports (if EUT with antenna diversity architecture).
- Following channel(s) was (were) selected for the final test as listed below.

MODE	AVAILABLE CHANNEL	TESTED CHANNEL	MODULATION TECHNOLOGY	MODULATION TYPE	DATA RATE (MBPS)
802.11n (20MHz)	36 to 48	48	OFDM	BPSK	6.5

RADIATED EMISSION TEST (BELOW 1 GHz):

- Pre-Scan has been conducted to determine the worst-case mode from all possible combinations between available modulations, data rates and antenna ports (if EUT with antenna diversity architecture).
- Following channel(s) was (were) selected for the final test as listed below.

MODE	AVAILABLE CHANNEL	TESTED CHANNEL	MODULATION TECHNOLOGY	MODULATION TYPE	DATA RATE (Mbps)
802.11n (20MHz)	36 to 48	48	OFDM	BPSK	6.5

RADIATED EMISSION TEST (ABOVE 1 GHz):

- Pre-Scan has been conducted to determine the worst-case mode from all possible combinations between available modulations, data rates and antenna ports (if EUT with antenna diversity architecture).
- Following channel(s) was (were) selected for the final test as listed below.

MODE	AVAILABLE CHANNEL	TESTED CHANNEL	MODULATION TECHNOLOGY	MODULATION TYPE	DATA RATE (Mbps)
802.11a	36 to 48	36, 40, 48	OFDM	BPSK	6
802.11n (20MHz)	36 to 48	36, 40, 48	OFDM	BPSK	6.5
802.11n (40MHz)	38 to 46	38, 46	OFDM	BPSK	13.5



A D T

ANTENNA PORT CONDUCTED MEASUREMENT:

- This item includes all test value of each mode, but only includes spectrum plot of worst value of each mode.
- Pre-Scan has been conducted to determine the worst-case mode from all possible combinations between available modulations, data rates and antenna ports (if EUT with antenna diversity architecture).
- Following channel(s) was (were) selected for the final test as listed below.

MODE	AVAILABLE CHANNEL	TESTED CHANNEL	MODULATION TECHNOLOGY	MODULATION TYPE	DATA RATE (Mbps)
802.11a	36 to 48	36, 40, 48	OFDM	BPSK	6
802.11n (20MHz)	36 to 48	36, 40, 48	OFDM	BPSK	6.5
802.11n (40MHz)	38 to 46	38, 46	OFDM	BPSK	13.5

TEST CONDITION:

APPLICABLE TO	ENVIRONMENTAL CONDITIONS	INPUT POWER	TESTED BY
PLC	24deg. C, 75%RH	120Vac, 60Hz	Scott Chen
RE<1G	19deg. C, 62%RH	120Vac, 60Hz	Nick Chang
RE ³ 1G	23deg. C, 69%RH	120Vac, 60Hz	Frank Liu
APCM	25deg. C, 60%RH	120Vac, 60Hz	Rex Huang
OB	25deg. C, 60%RH	120Vac, 60Hz	Rex Huang

3.3 GENERAL DESCRIPTION OF APPLIED STANDARDS

The EUT is a RF product. According to the specifications of the manufacturer, it must comply with the requirements of the following standards:

FCC Part 15, Subpart E (15.407)

ANSI C63.10-2009

All test items have been performed and recorded as per the above standards.

NOTE: The EUT is also considered as a kind of computer peripheral, because the connection to computer is necessary for typical use. It has been verified to comply with the requirements of FCC Part 15, Subpart B, Class B (DoC). The test report has been issued separately.

3.4 DUTY CYCLE OF TEST SIGNAL

Test tool can set the EUT to transmit at > 98 % duty cycle.



A D T

3.5 DESCRIPTION OF SUPPORT UNITS

The EUT has been tested as an independent unit together with other necessary accessories or support units. The following support units or accessories were used to form a representative test configuration during the tests.

No.	Product	Brand	Model No.	Serial No.	FCC ID
1	NOTEBOOK COMPUTER	DELL	PP32LA	FSLB32S	FCC DoC
2	NOTEBOOK COMPUTER	DELL	PP32LA	GSLB32S	FCC DoC
3	HUB	ZyXEL	ES-116P	S060H02000215	FCC DoC
4	HDD	WD	WDBAAE5000A SL-PESN	WX51A6172904	FCC DoC

No.	Signal cable description
1	UTP cable (10m)
2	UTP cable (10m)
3	UTP cable (10m)
4	USB cable (0.3m)

Note: The power cords of the above support units were unshielded (1.8m).

3.6 CONFIGURATION OF SYSTEM UNDER TEST

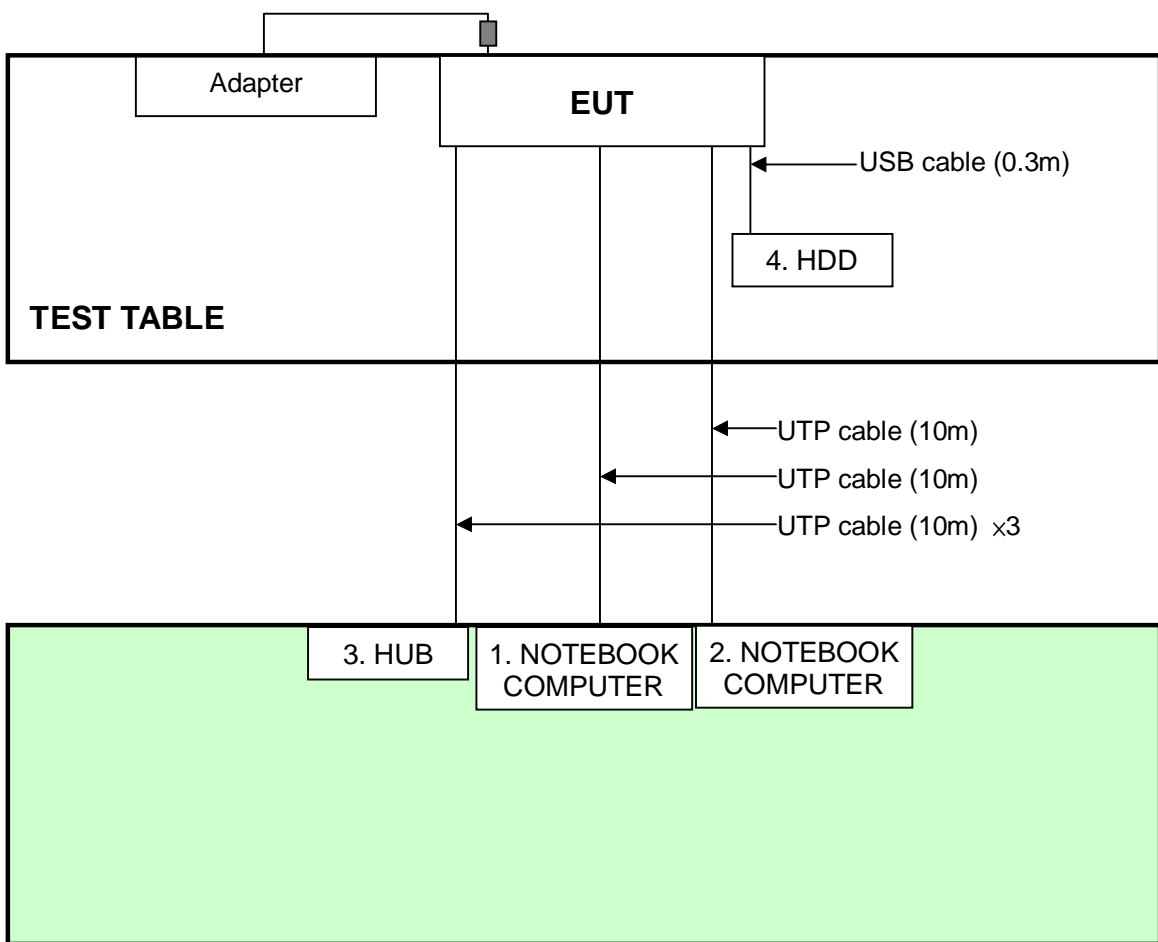



A D T

4. TEST TYPES AND RESULTS

4.1 CONDUCTED EMISSION MEASUREMENT

4.1.1 LIMITS OF CONDUCTED EMISSION MEASUREMENT

FREQUENCY OF EMISSION (MHz)	CONDUCTED LIMIT (dB μ V)	
	Quasi-peak	Average
0.15-0.5	66 to 56	56 to 46
0.5-5	56	46
5-30	60	50

- NOTE:**
1. The lower limit shall apply at the transition frequencies.
 2. The limit decreases in line with the logarithm of the frequency in the range of 0.15 to 0.50 MHz.

4.1.2 TEST INSTRUMENTS

DESCRIPTION & MANUFACTURER	MODEL NO.	SERIAL NO.	CALIBRATED DATE	CALIBRATED UNTIL
Test Receiver	ESCS 30	100375	Mar. 09, 2011	Mar. 08, 2012
Line-Impedance Stabilization Network (for EUT)	NSLK8127	8127-522	Sep. 07, 2011	Sep. 06, 2012
Line-Impedance Stabilization Network (for Peripheral)	ESH3-Z5	848773/004	Nov. 02, 2011	Nov. 01, 2012
RF Cable (JYEBAO)	5DFB	COCCAB-002	Aug. 29, 2011	Aug. 28, 2012
50 ohms Terminator	50	3	Nov. 02, 2011	Nov. 01, 2012
Software	BV ADT_Cond_V7.3.7	NA	NA	NA

Note:

1. The calibration interval of the above test instruments is 12 months and the calibrations are traceable to NML/ROC and NIST/USA.
2. The test was performed in Shielded Room No. C.
3. The VCCI Con C Registration No. is C-3611.
4. Tested Date: Feb. 17, 2012

4.1.3 TEST PROCEDURES

- a. The EUT was placed 0.4 meters from the conducting wall of the shielded room with EUT being connected to the power mains through a line impedance stabilization network (LISN). Other support units were connected to the power mains through another LISN.
- b. The two LISNs provide 50 ohm/ 50uH of coupling impedance for the measuring instrument.
- c. Both lines of the power mains connected to the EUT were checked for maximum conducted interference.
- d. The frequency range from 150kHz to 30MHz was searched. Emission level under (Limit – 20dB) was not recorded.

4.1.4 DEVIATION FROM TEST STANDARD

No deviation

4.1.5 TEST SETUP

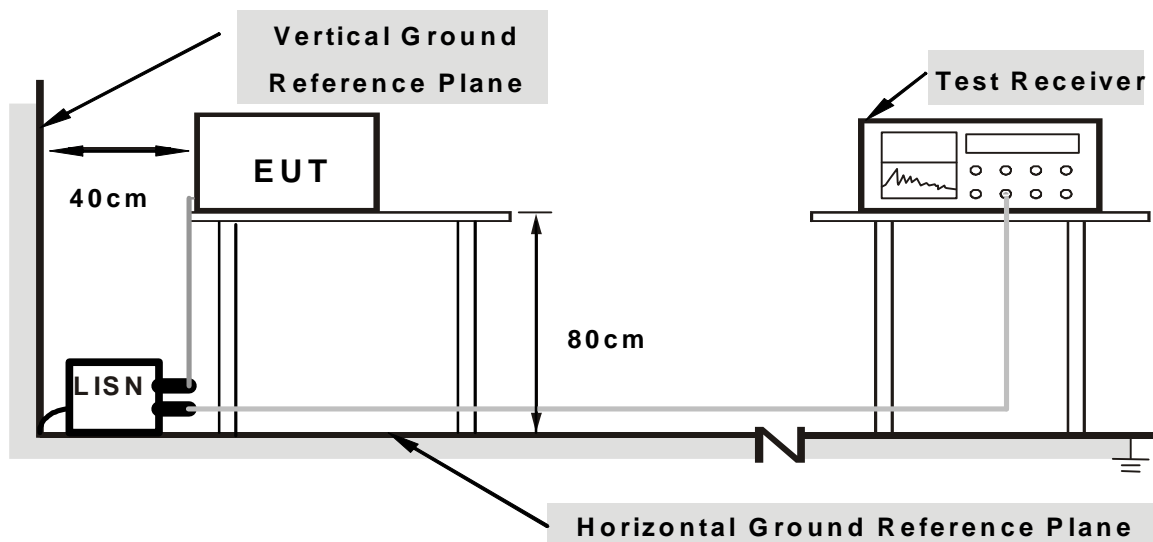

Note: 1. Support units were connected to second LISN.

2. Both of LISNs (AMN) are 80 cm from EUT and at least 80 from other units and other metal planes

For the actual test configuration, please refer to the related item – Photographs of the Test Configuration.

4.1.6 EUT OPERATING CONDITIONS

1. Placed the EUT on testing table.
2. Prepared other computer system (support unit 1) to act as communication partners and placed them outside of testing area.
3. The communication partners ran test program “artgui.exe” to enable EUT under transmission/receiving condition continuously via UTP cables transmission.

4.1.7 TEST RESULTS

PHASE	Line (L)	6dB BANDWIDTH	9 kHz
--------------	----------	----------------------	-------

No	Freq.	Corr.	Reading Value		Emission Level		Limit		Margin	
	[MHz]	Factor	[dB (uV)]		[dB (uV)]		[dB (uV)]		(dB)	
		(dB)	Q.P.	AV.	Q.P.	AV.	Q.P.	AV.	Q.P.	AV.
1	0.15345	0.09	44.56	31.89	44.65	31.98	65.81	55.81	-21.16	-23.83
2	0.18777	0.10	40.86	29.65	40.96	29.75	64.13	54.13	-23.17	-24.38
3	0.37644	0.14	33.67	27.22	33.81	27.36	58.36	48.36	-24.55	-21.00
4	0.94333	0.19	27.76	22.01	27.95	22.20	56.00	46.00	-28.05	-23.80
5	4.91123	0.45	27.21	21.33	27.66	21.78	56.00	46.00	-28.34	-24.22
6	10.09758	0.72	25.76	20.66	26.48	21.38	60.00	50.00	-33.52	-28.62

- REMARKS:**
1. Q.P. and AV. are abbreviations of quasi-peak and average individually.
 2. "-": The Quasi-peak reading value also meets average limit and measurement with the average detector is unnecessary.
 3. The emission levels of other frequencies were very low against the limit.
 4. Margin value = Emission level - Limit value
 5. Correction factor = Insertion loss + Cable loss
 6. Emission Level = Correction Factor + Reading Value.

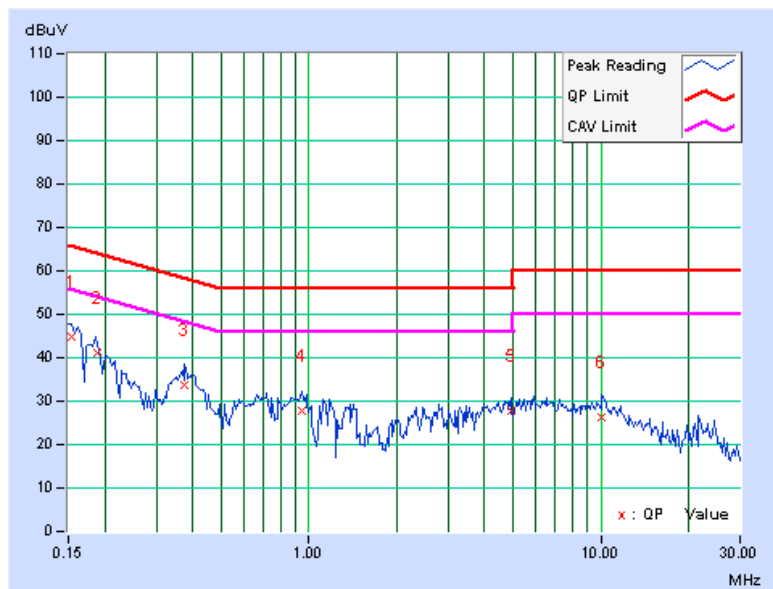



A D T

PHASE	Neutral (N)	6dB BANDWIDTH	9 kHz
-------	-------------	---------------	-------

No	Freq. [MHz]	Corr. Factor (dB)	Reading Value [dB (uV)]		Emission Level [dB (uV)]		Limit [dB (uV)]		Margin (dB)	
			Q.P.	AV.	Q.P.	AV.	Q.P.	AV.	Q.P.	AV.
			1	0.16105	0.08	43.53	32.43	43.61	32.51	65.41
2	0.18868	0.09	40.27	28.58	40.36	28.67	64.09	54.09	-23.73	-25.42
3	0.39666	0.13	34.24	27.64	34.37	27.77	57.92	47.92	-23.55	-20.15
4	1.65346	0.18	28.65	22.77	28.83	22.95	56.00	46.00	-27.17	-23.05
5	3.87374	0.30	29.56	22.26	29.86	22.56	56.00	46.00	-26.14	-23.44
6	9.12866	0.55	26.56	20.34	27.11	20.89	60.00	50.00	-32.89	-29.11

- REMARKS:**
1. Q.P. and AV. are abbreviations of quasi-peak and average individually.
 2. "-": The Quasi-peak reading value also meets average limit and measurement with the average detector is unnecessary.
 3. The emission levels of other frequencies were very low against the limit.
 4. Margin value = Emission level - Limit value
 5. Correction factor = Insertion loss + Cable loss
 6. Emission Level = Correction Factor + Reading Value.

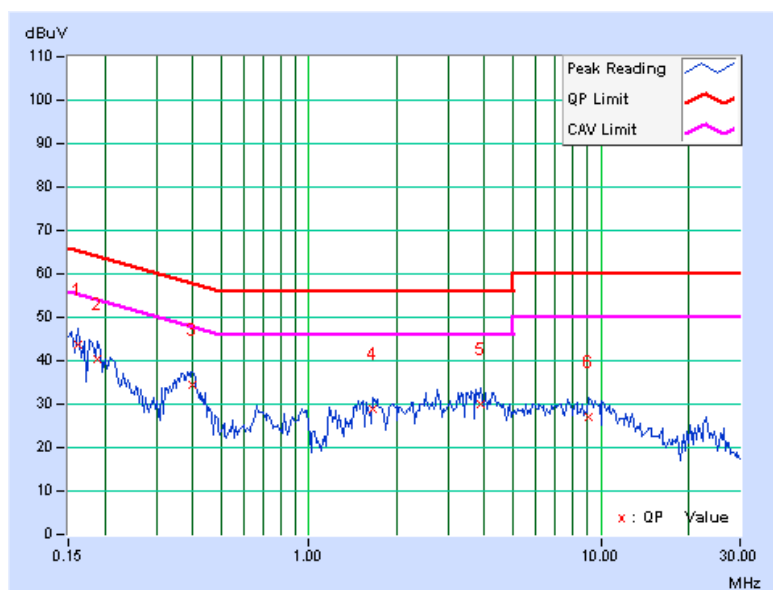

4.2 RADIATED EMISSION MEASUREMENT

4.2.1 LIMITS OF RADIATED EMISSION MEASUREMENT

Radiated emissions which fall in the restricted bands must comply with the radiated emission limits specified as below table:

Frequencies (MHz)	Field strength (microvolts/meter)	Measurement distance (meters)
0.009-0.490	2400/F(kHz)	300
0.490-1.705	24000/F(kHz)	30
1.705-30.0	30	30
30-88	100	3
88-216	150	3
216-960	200	3
Above 960	500	3

NOTE:

1. The lower limit shall apply at the transition frequencies.
2. Emission level (dBuV/m) = 20 log Emission level (uV/m).
3. For frequencies above 1000MHz, the field strength limits are based on average detector, however, the peak field strength of any emission shall not exceed the maximum permitted average limits, specified above by more than 20dB under any condition of modulation.



A D T

4.2.2 LIMITS OF UNWANTED EMISSION OUT OF THE RESTRICTED BANDS

Frequencies (MHz)	EIRP Limit (dBm)	Equivalent Field Strength at 3m (dBµV/m) *note 3
5150~5250	-27	68.3
5250~5350	-27	68.3
5470~5725	-27	68.3
5725~5825	-27 *note 1	68.3
	-17 *note 2	78.3

NOTE:

1. For frequencies 10MHz or greater above or below the band edge.
2. All emissions within the frequency range from the band edge to 10MHz above or below the band edge.
3. The following formula is used to convert the equipment isotropic radiated power (eirp) to field strength

$$E = \frac{1000000\sqrt{30P}}{3} \mu\text{V/m, where P is the eirp (Watts)}$$



A D T

4.2.3 TEST INSTRUMENTS

For below 1GHz

DESCRIPTION & MANUFACTURER	MODEL NO.	SERIAL NO.	CALIBRATED DATE	CALIBRATED UNTIL
Agilent Spectrum Analyzer	E4446A	MY48250254	July 12, 2011	July 11, 2012
Agilent Pre-Selector	N9039A	MY46520311	July 12, 2011	July 11, 2012
Agilent Signal Generator	N5181A	MY49060517	July 12, 2011	July 11, 2012
Mini-Circuits Pre-Amplifier	ZFL-1000VH2B	AMP-ZFL-03	Nov. 15, 2011	Nov. 14, 2012
Agilent Pre-Amplifier	8449B	3008A02578	July 04, 2011	July 03, 2012
SPACEK LABS	SLKKa-48-6	9K16	Nov. 15, 2011	Nov. 14, 2012
SCHWARZBECK Trilog Broadband Antenna	VULB 9168	9168-360	Apr. 14, 2011	Apr. 13, 2012
AISI Horn_Antenna	AIH.8018	0000320091110	Nov. 14, 2011	Nov. 13, 2012
SCHWARZBECK Horn_Antenna	BBHA 9170	9170-424	Oct. 07, 2011	Oct. 06, 2012
RF CABLE	NA	RF104-201 RF104-203 RF104-204	Dec. 26, 2011	Dec. 25, 2012
RF Cable	NA	CHGCAB_001	Oct. 07, 2011	Oct. 06, 2012
Software	ADT_Radiated_V8.7.05	NA	NA	NA
CT Antenna Tower & Turn Table	NA	NA	NA	NA

Note: 1. The calibration interval of the above test instruments is 12 months and the calibrations are traceable to NML/ROC and NIST/USA.

2. The horn antenna, preamplifier (model: 8449B) are used only for the measurement of emission frequency above 1GHz if tested.

3. The test was performed in 966 Chamber No. G.

4. The FCC Site Registration No. is 966073.

5. The VCCI Site Registration No. is G-137.

6. The CANADA Site Registration No. is IC 7450H-2.

7. Tested Date: Feb. 15, 2012



A D T

For above 1GHz

DESCRIPTION & MANUFACTURER	MODEL NO.	SERIAL NO.	CALIBRATED DATE	CALIBRATED UNTIL
Agilent Spectrum Analyzer	E4446A	MY48250253	Aug. 29, 2011	Aug. 28, 2012
Agilent Pre-Selector	N9039A	MY46520310	Aug. 29, 2011	Aug. 28, 2012
Agilent Signal Generator	N5181A	MY49060347	July 25, 2011	July 24, 2012
Mini-Circuits Pre-Amplifier	ZFL-1000VH2B	AMP-ZFL-04	Nov. 15, 2011	Nov. 14, 2012
Agilent Pre-Amplifier	8449B	3008A02465	Feb. 28, 2011	Feb. 27, 2012
SPACEK LABS	SLKKa-48-6	9K16	Nov. 15, 2011	Nov. 14, 2012
SCHWARZBECK Trilog Broadband Antenna	VULB 9168	9168-361	Apr. 14, 2011	Apr. 13, 2012
AISI Horn_Antenna	AIH.8018	0000220091110	Nov. 23, 2011	Nov. 22, 2012
SCHWARZBECK Horn_Antenna	BBHA 9170	9170-424	Oct. 07, 2011	Oct. 06, 2012
RF CABLE	NA	RF104-205 RF104-207 RF104-202	Dec. 27, 2011	Dec. 26, 2012
RF Cable	NA	CHHCAB_001	Oct. 08, 2011	Oct. 07, 2012
Software	ADT_Radiated_V8.7.05	NA	NA	NA
CT Antenna Tower & Turn Table	NA	NA	NA	NA

- Note: 1. The calibration interval of the above test instruments is 12 months and the calibrations are traceable to NML/ROC and NIST/USA.
2. The horn antenna, preamplifier (model: 8449B) are used only for the measurement of emission frequency above 1GHz if tested.
3. The test was performed in 966 Chamber No. H.
4. The FCC Site Registration No. is 797305.
5. The CANADA Site Registration No. is IC 7450H-3.
6. Tested Date: Feb. 17, 2012

4.2.4 TEST PROCEDURES

- a. The EUT was placed on the top of a rotating table 0.8 meters above the ground at 3 meter chamber room. The table was rotated 360 degrees to determine the position of the highest radiation.
- b. The EUT was set 3 meters away from the interference-receiving antenna, which was mounted on the top of a variable-height antenna tower.
- c. The height of antenna is varied from one meter to four meters above the ground to determine the maximum value of the field strength. Both horizontal and vertical polarizations of the antenna are set to make the measurement.
- d. For each suspected emission, the EUT was arranged to its worst case and then the antenna was tuned to heights from 1 meter to 4 meters and the rotatable table was turned from 0 degrees to 360 degrees to find the maximum reading.
- e. The test-receiver system was set to quasi-peak detect function and specified bandwidth with maximum hold mode when the test frequency is below 1 GHz.
- f. The test-receiver system was set to peak and average detect function and specified bandwidth with maximum hold mode when the test frequency is above 1 GHz. If the peak reading value also meets average limit, measurement with the average detector is unnecessary.

NOTE:

1. The resolution bandwidth and video bandwidth of test receiver/spectrum analyzer is 120kHz for Quasi-peak detection (QP) at frequency below 1GHz.
2. The resolution bandwidth of test receiver/spectrum analyzer is 1 MHz and the video bandwidth is 3 MHz for Peak detection (PK) at frequency above 1GHz.
3. The resolution bandwidth of test receiver/spectrum analyzer is 1 MHz and the video bandwidth is 10 Hz for Average detection (AV) at frequency above 1GHz.
4. All modes of operation were investigated and the worst-case emissions are reported.

4.2.5 DEVIATION FROM TEST STANDARD

No deviation

4.2.6 TEST SETUP

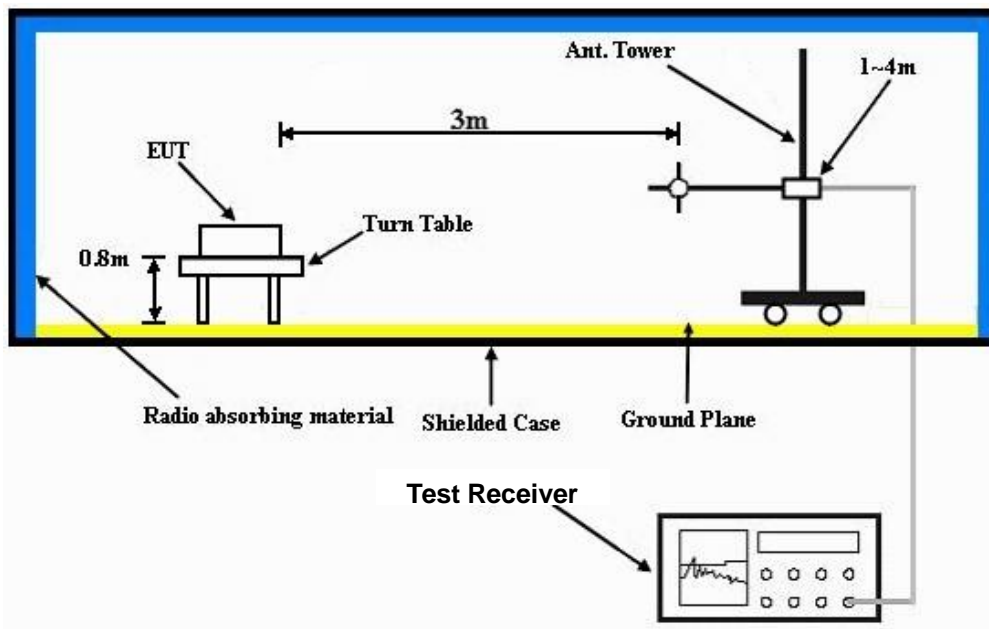

For the actual test configuration, please refer to the related item – Photographs of the Test Configuration.

4.2.7 EUT OPERATING CONDITION

Same as 4.1.6



A D T

4.2.8 TEST RESULTS

BELOW 1GHz WORST-CASE DATA

802.11n (20MHz)

CHANNEL	TX Channel 48	DETECTOR FUNCTION	Quasi-Peak (QP)
FREQUENCY RANGE	30MHz ~ 1GHz		

ANTENNA POLARITY & TEST DISTANCE: HORIZONTAL AT 3 M

NO.	FREQ. (MHz)	EMISSION LEVEL (dBuV/m)	LIMIT (dBuV/m)	MARGIN (dB)	ANTENNA HEIGHT (m)	TABLE ANGLE (Degree)	RAW VALUE (dBuV)	CORRECTION FACTOR (dB/m)
1	133.86	24.2 QP	43.5	-19.3	2.00 H	276	10.46	13.73
2	239.96	24.8 QP	46.0	-21.2	1.00 H	82	11.84	12.96
3	374.97	32.2 QP	46.0	-13.8	1.00 H	125	14.89	17.28
4	500.02	25.7 QP	46.0	-20.3	1.50 H	91	5.43	20.31
5	599.97	24.4 QP	46.0	-21.6	1.50 H	360	1.83	22.58
6	720.05	33.1 QP	46.0	-12.9	1.00 H	144	9.53	23.60

ANTENNA POLARITY & TEST DISTANCE: VERTICAL AT 3 M

NO.	FREQ. (MHz)	EMISSION LEVEL (dBuV/m)	LIMIT (dBuV/m)	MARGIN (dB)	ANTENNA HEIGHT (m)	TABLE ANGLE (Degree)	RAW VALUE (dBuV)	CORRECTION FACTOR (dB/m)
1	65.65	28.2 QP	40.0	-11.8	1.00 V	175	15.17	13.03
2	128.88	28.0 QP	43.5	-15.5	1.00 V	360	14.67	13.32
3	239.96	23.2 QP	46.0	-22.9	1.00 V	74	10.19	12.96
4	374.97	31.2 QP	46.0	-14.8	1.00 V	288	13.95	17.28
5	500.02	28.5 QP	46.0	-17.6	1.00 V	17	8.14	20.31
6	720.05	29.5 QP	46.0	-16.5	1.50 V	301	5.93	23.60

- REMARKS:**
1. Emission level (dBuV/m) = Raw Value (dBuV) + Correction Factor (dB/m).
 2. Correction Factor (dB/m) = Antenna Factor (dB/m) + Cable Factor (dB).
 3. The other emission levels were very low against the limit.
 4. Margin value = Emission level – Limit value.



A D T

ABOVE 1GHz DATA

802.11a

CHANNEL	TX Channel 36	DETECTOR FUNCTION	Peak (PK)
FREQUENCY RANGE	1GHz ~ 40GHz		Average (AV)

ANTENNA POLARITY & TEST DISTANCE: HORIZONTAL AT 3 M

NO.	FREQ. (MHz)	EMISSION LEVEL (dBuV/m)	LIMIT (dBuV/m)	MARGIN (dB)	ANTENNA HEIGHT (m)	TABLE ANGLE (Degree)	RAW VALUE (dBuV)	CORRECTIO N FACTOR (dB/m)
1	5103.40	58.7 PK	74.0	-15.3	1.29 H	68	17.04	41.66
2	5103.40	47.1 AV	54.0	-6.9	1.29 H	68	5.44	41.66
3	*5180.00	107.2 PK			1.29 H	68	65.44	41.76
4	*5180.00	97.4 AV			1.29 H	68	55.64	41.76
5	5440.00	60.1 PK	74.0	-13.9	1.00 H	113	17.89	42.21
6	5440.00	52.1 AV	54.0	-1.9	1.00 H	113	9.89	42.21
7	#10360.00	58.2 PK	68.3	-10.1	1.00 H	55	9.68	48.52
8	15540.00	64.5 PK	74.0	-9.5	1.00 H	37	10.43	54.07
9	15540.00	49.3 AV	54.0	-4.7	1.00 H	37	-4.77	54.07

ANTENNA POLARITY & TEST DISTANCE: VERTICAL AT 3 M

NO.	FREQ. (MHz)	EMISSION LEVEL (dBuV/m)	LIMIT (dBuV/m)	MARGIN (dB)	ANTENNA HEIGHT (m)	TABLE ANGLE (Degree)	RAW VALUE (dBuV)	CORRECTIO N FACTOR (dB/m)
1	5150.00	58.5 PK	74.0	-15.5	1.15 V	247	16.78	41.72
2	5150.00	47.1 AV	54.0	-6.9	1.15 V	247	5.38	41.72
3	*5180.00	96.5 PK			1.15 V	247	54.74	41.76
4	*5180.00	86.9 AV			1.15 V	247	45.14	41.76
5	#10360.00	57.5 PK	68.3	-10.8	1.00 V	64	8.98	48.52
6	15540.00	64.3 PK	74.0	-9.7	1.00 V	44	10.23	54.07
7	15540.00	49.7 AV	54.0	-4.3	1.00 V	44	-4.37	54.07

- REMARKS:**
1. Emission level (dBuV/m) = Raw Value (dBuV) + Correction Factor (dB/m).
 2. Correction Factor (dB/m) = Antenna Factor (dB/m) + Cable Factor (dB).
 3. The other emission levels were very low against the limit.
 4. Margin value = Emission level – Limit value.
 5. " * ": Fundamental frequency.
 6. " # ": The radiated frequency is out of the restricted band.



A D T

CHANNEL	TX Channel 40	DETECTOR FUNCTION	Peak (PK)
FREQUENCY RANGE	1GHz ~ 40GHz		Average (AV)

ANTENNA POLARITY & TEST DISTANCE: HORIZONTAL AT 3 M

NO.	FREQ. (MHz)	EMISSION LEVEL (dBuV/m)	LIMIT (dBuV/m)	MARGIN (dB)	ANTENNA HEIGHT (m)	TABLE ANGLE (Degree)	RAW VALUE (dBuV)	CORRECTION FACTOR (dB/m)
1	*5200.00	105.5 PK			1.32 H	122	63.72	41.78
2	*5200.00	94.7 AV			1.32 H	122	52.92	41.78
3	5440.00	60.4 PK	74.0	-13.6	1.00 H	114	18.19	42.21
4	5440.00	51.7 AV	54.0	-2.3	1.00 H	114	9.49	42.21
5	#10400.00	58.4 PK	68.3	-9.9	1.00 H	49	9.72	48.68
6	15600.00	65.0 PK	74.0	-9.0	1.00 H	44	11.42	53.58
7	15600.00	49.7 AV	54.0	-4.3	1.00 H	44	-3.88	53.58

ANTENNA POLARITY & TEST DISTANCE: VERTICAL AT 3 M

NO.	FREQ. (MHz)	EMISSION LEVEL (dBuV/m)	LIMIT (dBuV/m)	MARGIN (dB)	ANTENNA HEIGHT (m)	TABLE ANGLE (Degree)	RAW VALUE (dBuV)	CORRECTION FACTOR (dB/m)
1	*5200.00	96.8 PK			1.18 V	258	55.02	41.78
2	*5200.00	87.1 AV			1.18 V	258	45.32	41.78
3	#10400.00	57.4 PK	68.3	-10.9	1.00 V	73	8.72	48.68
4	15600.00	64.5 PK	74.0	-9.5	1.00 V	56	10.92	53.58
5	15600.00	49.6 AV	54.0	-4.4	1.00 V	56	-3.98	53.58

- REMARKS:**
1. Emission level (dBuV/m) = Raw Value (dBuV) + Correction Factor (dB/m).
 2. Correction Factor (dB/m) = Antenna Factor (dB/m) + Cable Factor (dB).
 3. The other emission levels were very low against the limit.
 4. Margin value = Emission level – Limit value.
 5. " * ": Fundamental frequency.
 6. " # ": The radiated frequency is out of the restricted band.



A D T

CHANNEL	TX Channel 48	DETECTOR FUNCTION	Peak (PK)
FREQUENCY RANGE	1GHz ~ 40GHz		Average (AV)

ANTENNA POLARITY & TEST DISTANCE: HORIZONTAL AT 3 M

NO.	FREQ. (MHz)	EMISSION LEVEL (dBuV/m)	LIMIT (dBuV/m)	MARGIN (dB)	ANTENNA HEIGHT (m)	TABLE ANGLE (Degree)	RAW VALUE (dBuV)	CORRECTION FACTOR (dB/m)
1	*5240.00	108.0 PK			1.25 H	117	66.13	41.87
2	*5240.00	98.2 AV			1.25 H	117	56.33	41.87
3	5440.00	60.6 PK	74.0	-13.4	1.00 H	114	18.39	42.21
4	5440.00	51.9 AV	54.0	-2.1	1.00 H	114	9.69	42.21
5	#10480.00	58.6 PK	68.3	-9.7	1.00 H	56	9.98	48.62
6	15720.00	65.3 PK	74.0	-8.7	1.00 H	49	11.44	53.86
7	15720.00	49.5 AV	54.0	-4.5	1.00 H	49	-4.36	53.86

ANTENNA POLARITY & TEST DISTANCE: VERTICAL AT 3 M

NO.	FREQ. (MHz)	EMISSION LEVEL (dBuV/m)	LIMIT (dBuV/m)	MARGIN (dB)	ANTENNA HEIGHT (m)	TABLE ANGLE (Degree)	RAW VALUE (dBuV)	CORRECTION FACTOR (dB/m)
1	*5240.00	100.5 PK			1.14 V	249	58.63	41.87
2	*5240.00	91.2 AV			1.14 V	249	49.33	41.87
3	5350.00	59.5 PK	74.0	-14.5	1.15 V	249	17.41	42.09
4	5350.00	47.6 AV	54.0	-6.4	1.15 V	249	5.51	42.09
5	#10480.00	57.5 PK	68.3	-10.8	1.00 V	69	8.88	48.62
6	15720.00	64.3 PK	74.0	-9.7	1.00 V	62	10.44	53.86
7	15720.00	49.7 AV	54.0	-4.3	1.00 V	62	-4.16	53.86

- REMARKS:**
1. Emission level (dBuV/m) = Raw Value (dBuV) + Correction Factor (dB/m).
 2. Correction Factor (dB/m) = Antenna Factor (dB/m) + Cable Factor (dB).
 3. The other emission levels were very low against the limit.
 4. Margin value = Emission level – Limit value.
 5. " * ": Fundamental frequency.
 6. " # ": The radiated frequency is out of the restricted band.



802.11n (20MHz)

CHANNEL	TX Channel 36	DETECTOR FUNCTION	Peak (PK)
FREQUENCY RANGE	1GHz ~ 40GHz		Average (AV)

ANTENNA POLARITY & TEST DISTANCE: HORIZONTAL AT 3 M

NO.	FREQ. (MHz)	EMISSION LEVEL (dBuV/m)	LIMIT (dBuV/m)	MARGIN (dB)	ANTENNA HEIGHT (m)	TABLE ANGLE (Degree)	RAW VALUE (dBuV)	CORRECTION FACTOR (dB/m)
1	5150.00	60.2 PK	74.0	-13.8	1.27 H	68	18.48	41.72
2	5150.00	47.8 AV	54.0	-6.2	1.27 H	68	6.08	41.72
3	*5180.00	105.6 PK			1.27 H	68	63.84	41.76
4	*5180.00	96.3 AV			1.27 H	68	54.54	41.76
5	5440.00	62.6 PK	74.0	-11.4	1.00 H	113	20.39	42.21
6	5440.00	53.5 AV	54.0	-0.5	1.00 H	113	11.29	42.21
7	#10360.00	58.4 PK	68.3	-9.9	1.00 H	52	9.88	48.52
8	15540.00	65.2 PK	74.0	-8.8	1.00 H	64	11.13	54.07
9	15540.00	49.4 AV	54.0	-4.6	1.00 H	64	-4.67	54.07

ANTENNA POLARITY & TEST DISTANCE: VERTICAL AT 3 M

NO.	FREQ. (MHz)	EMISSION LEVEL (dBuV/m)	LIMIT (dBuV/m)	MARGIN (dB)	ANTENNA HEIGHT (m)	TABLE ANGLE (Degree)	RAW VALUE (dBuV)	CORRECTION FACTOR (dB/m)
1	5150.00	59.1 PK	74.0	-14.9	1.17 V	236	17.38	41.72
2	5150.00	47.5 AV	54.0	-6.5	1.17 V	236	5.78	41.72
3	*5180.00	96.3 PK			1.17 V	235	54.54	41.76
4	*5180.00	86.9 AV			1.17 V	235	45.14	41.76
5	#10360.00	57.9 PK	68.3	-10.4	1.00 V	73	9.38	48.52
6	15540.00	64.5 PK	74.0	-9.5	1.00 V	64	10.43	54.07
7	15540.00	49.2 AV	54.0	-4.8	1.00 V	64	-4.87	54.07

- REMARKS:**
1. Emission level (dBuV/m) = Raw Value (dBuV) + Correction Factor (dB/m).
 2. Correction Factor (dB/m) = Antenna Factor (dB/m) + Cable Factor (dB).
 3. The other emission levels were very low against the limit.
 4. Margin value = Emission level – Limit value.
 5. " * ": Fundamental frequency.
 6. " # ": The radiated frequency is out of the restricted band.



A D T

CHANNEL	TX Channel 40	DETECTOR FUNCTION	Peak (PK)
FREQUENCY RANGE	1GHz ~ 40GHz		Average (AV)

ANTENNA POLARITY & TEST DISTANCE: HORIZONTAL AT 3 M

NO.	FREQ. (MHz)	EMISSION LEVEL (dBuV/m)	LIMIT (dBuV/m)	MARGIN (dB)	ANTENNA HEIGHT (m)	TABLE ANGLE (Degree)	RAW VALUE (dBuV)	CORRECTIO N FACTOR (dB/m)
1	*5200.00	106.1 PK			1.32 H	115	64.32	41.78
2	*5200.00	95.2 AV			1.32 H	115	53.42	41.78
3	5440.00	62.2 PK	74.0	-11.8	1.00 H	113	19.99	42.21
4	5440.00	53.1 AV	54.0	-0.9	1.00 H	113	10.89	42.21
5	#10400.00	58.2 PK	68.3	-10.1	1.00 H	69	9.52	48.68
6	15600.00	65.4 PK	74.0	-8.6	1.00 H	57	11.82	53.58
7	15600.00	49.7 AV	54.0	-4.3	1.00 H	57	-3.88	53.58

ANTENNA POLARITY & TEST DISTANCE: VERTICAL AT 3 M

NO.	FREQ. (MHz)	EMISSION LEVEL (dBuV/m)	LIMIT (dBuV/m)	MARGIN (dB)	ANTENNA HEIGHT (m)	TABLE ANGLE (Degree)	RAW VALUE (dBuV)	CORRECTIO N FACTOR (dB/m)
1	*5200.00	97.1 PK			1.20 V	240	55.32	41.78
2	*5200.00	87.5 AV			1.20 V	240	45.72	41.78
3	#10400.00	57.3 PK	68.3	-11.0	1.00 V	64	8.62	48.68
4	15600.00	64.3 PK	74.0	-9.7	1.00 V	59	10.72	53.58
5	15600.00	49.6 AV	54.0	-4.4	1.00 V	59	-3.98	53.58

- REMARKS:**
1. Emission level (dBuV/m) = Raw Value (dBuV) + Correction Factor (dB/m).
 2. Correction Factor (dB/m) = Antenna Factor (dB/m) + Cable Factor (dB).
 3. The other emission levels were very low against the limit.
 4. Margin value = Emission level – Limit value.
 5. " * ": Fundamental frequency.
 6. " # ": The radiated frequency is out of the restricted band.



A D T

CHANNEL	TX Channel 48	DETECTOR FUNCTION	Peak (PK)
FREQUENCY RANGE	1GHz ~ 40GHz		Average (AV)

ANTENNA POLARITY & TEST DISTANCE: HORIZONTAL AT 3 M

NO.	FREQ. (MHz)	EMISSION LEVEL (dBuV/m)	LIMIT (dBuV/m)	MARGIN (dB)	ANTENNA HEIGHT (m)	TABLE ANGLE (Degree)	RAW VALUE (dBuV)	CORRECTION FACTOR (dB/m)
1	*5240.00	108.2 PK			1.30 H	112	66.33	41.87
2	*5240.00	98.3 AV			1.30 H	112	56.43	41.87
3	5440.00	63.1 PK	74.0	-10.9	1.00 H	113	20.89	42.21
4	5440.00	53.5 AV	54.0	-0.5	1.00 H	113	11.29	42.21
5	#10480.00	58.4 PK	68.3	-9.9	1.00 H	64	9.78	48.62
6	15720.00	65.2 PK	74.0	-8.8	1.00 H	43	11.34	53.86
7	15720.00	49.5 AV	54.0	-4.5	1.00 H	43	-4.36	53.86

ANTENNA POLARITY & TEST DISTANCE: VERTICAL AT 3 M

NO.	FREQ. (MHz)	EMISSION LEVEL (dBuV/m)	LIMIT (dBuV/m)	MARGIN (dB)	ANTENNA HEIGHT (m)	TABLE ANGLE (Degree)	RAW VALUE (dBuV)	CORRECTION FACTOR (dB/m)
1	*5240.00	101.0 PK			1.20 V	238	59.13	41.87
2	*5240.00	91.6 AV			1.20 V	238	49.73	41.87
3	5350.00	60.1 PK	74.0	-13.9	1.19 V	255	18.01	42.09
4	5350.00	48.0 AV	54.0	-6.0	1.19 V	255	5.91	42.09
5	#10480.00	57.6 PK	68.3	-10.7	1.00 V	46	8.98	48.62
6	15720.00	64.2 PK	74.0	-9.8	1.00 V	63	10.34	53.86
7	15720.00	49.4 AV	54.0	-4.6	1.00 V	63	-4.46	53.86

- REMARKS:**
1. Emission level (dBuV/m) = Raw Value (dBuV) + Correction Factor (dB/m).
 2. Correction Factor (dB/m) = Antenna Factor (dB/m) + Cable Factor (dB).
 3. The other emission levels were very low against the limit.
 4. Margin value = Emission level – Limit value.
 5. " * ": Fundamental frequency.
 6. " # ": The radiated frequency is out of the restricted band.



A D T

802.11n (40MHz)

CHANNEL	TX Channel 38	DETECTOR FUNCTION	Peak (PK)
FREQUENCY RANGE	1GHz ~ 40GHz		Average (AV)

ANTENNA POLARITY & TEST DISTANCE: HORIZONTAL AT 3 M

NO.	FREQ. (MHz)	EMISSION LEVEL (dBuV/m)	LIMIT (dBuV/m)	MARGIN (dB)	ANTENNA HEIGHT (m)	TABLE ANGLE (Degree)	RAW VALUE (dBuV)	CORRECTION FACTOR (dB/m)
1	5150.00	68.7 PK	74.0	-5.3	1.30 H	68	26.98	41.72
2	5150.00	53.0 AV	54.0	-1.0	1.30 H	68	11.28	41.72
3	*5190.00	103.3 PK			1.29 H	67	61.53	41.77
4	*5190.00	93.5 AV			1.29 H	67	51.73	41.77
5	5440.00	63.2 PK	74.0	-10.8	1.00 H	114	20.99	42.21
6	5440.00	53.4 AV	54.0	-0.6	1.00 H	114	11.19	42.21
7	#10380.00	58.3 PK	68.3	-10.0	1.00 H	56	9.70	48.60
8	15570.00	65.3 PK	74.0	-8.7	1.00 H	39	11.48	53.82
9	15570.00	49.2 AV	54.0	-4.8	1.00 H	39	-4.62	53.82

ANTENNA POLARITY & TEST DISTANCE: VERTICAL AT 3 M

NO.	FREQ. (MHz)	EMISSION LEVEL (dBuV/m)	LIMIT (dBuV/m)	MARGIN (dB)	ANTENNA HEIGHT (m)	TABLE ANGLE (Degree)	RAW VALUE (dBuV)	CORRECTION FACTOR (dB/m)
1	5150.00	58.0 PK	74.0	-16.0	1.15 V	104	16.28	41.72
2	5150.00	47.2 AV	54.0	-6.8	1.15 V	104	5.48	41.72
3	*5190.00	95.6 PK			1.15 V	104	53.83	41.77
4	*5190.00	85.3 AV			1.15 V	104	43.53	41.77
5	#10380.00	57.3 PK	68.3	-11.0	1.00 V	56	8.70	48.60
6	15570.00	64.1 PK	74.0	-9.9	1.00 V	49	10.28	53.82
7	15570.00	49.2 AV	54.0	-4.8	1.00 V	49	-4.62	53.82

- REMARKS:**
1. Emission level (dBuV/m) = Raw Value (dBuV) + Correction Factor (dB/m).
 2. Correction Factor (dB/m) = Antenna Factor (dB/m) + Cable Factor (dB).
 3. The other emission levels were very low against the limit.
 4. Margin value = Emission level – Limit value.
 5. " * ": Fundamental frequency.
 6. " # ": The radiated frequency is out of the restricted band.



A D T

CHANNEL	TX Channel 46	DETECTOR FUNCTION	Peak (PK)
FREQUENCY RANGE	1GHz ~ 40GHz		Average (AV)

ANTENNA POLARITY & TEST DISTANCE: HORIZONTAL AT 3 M

NO.	FREQ. (MHz)	EMISSION LEVEL (dBuV/m)	LIMIT (dBuV/m)	MARGIN (dB)	ANTENNA HEIGHT (m)	TABLE ANGLE (Degree)	RAW VALUE (dBuV)	CORRECTION FACTOR (dB/m)
1	*5230.00	105.8 PK			1.31 H	113	63.95	41.85
2	*5230.00	95.6 AV			1.31 H	113	53.75	41.85
3	5440.00	63.0 PK	74.0	-11.0	1.00 H	115	20.79	42.21
4	5440.00	53.1 AV	54.0	-0.9	1.00 H	115	10.89	42.21
5	#10460.00	58.4 PK	68.3	-9.9	1.00 H	62	9.77	48.63
6	15690.00	65.6 PK	74.0	-8.4	1.00 H	43	11.79	53.81
7	15690.00	49.4 AV	54.0	-4.6	1.00 H	43	-4.41	53.81

ANTENNA POLARITY & TEST DISTANCE: VERTICAL AT 3 M

NO.	FREQ. (MHz)	EMISSION LEVEL (dBuV/m)	LIMIT (dBuV/m)	MARGIN (dB)	ANTENNA HEIGHT (m)	TABLE ANGLE (Degree)	RAW VALUE (dBuV)	CORRECTION FACTOR (dB/m)
1	*5230.00	98.7 PK			1.11 V	117	56.85	41.85
2	*5230.00	88.5 AV			1.11 V	117	46.65	41.85
3	5440.00	59.4 PK	74.0	-14.6	1.11 V	117	17.19	42.21
4	5440.00	47.7 AV	54.0	-6.3	1.11 V	117	5.49	42.21
5	#10460.00	57.6 PK	68.3	-10.7	1.00 V	64	8.97	48.63
6	15690.00	64.3 PK	74.0	-9.7	1.00 V	53	10.49	53.81
7	15690.00	49.6 AV	54.0	-4.4	1.00 V	53	-4.21	53.81

- REMARKS:**
1. Emission level (dBuV/m) = Raw Value (dBuV) + Correction Factor (dB/m).
 2. Correction Factor (dB/m) = Antenna Factor (dB/m) + Cable Factor (dB).
 3. The other emission levels were very low against the limit.
 4. Margin value = Emission level – Limit value.
 5. " * ": Fundamental frequency.
 6. " # ": The radiated frequency is out of the restricted band.



A D T

4.3 TRANSMIT POWER MEASUREMENT

4.3.1 LIMITS OF TRANSMIT POWER MEASUREMENT

Frequency Band	Limit
5.15 – 5.25GHz	The lesser of 50mW (17dBm) or 4dBm + 10logB
5.25 – 5.35GHz	The lesser of 250mW (24dBm) or 11dBm + 10logB
5.47 – 5.725GHz	The lesser of 250mW (24dBm) or 11dBm + 10logB
5.725 – 5.825GHz	The lesser of 1W (30dBm) or 17dBm + 10logB

NOTE: Where B is the 26dB emission bandwidth in MHz.

4.3.2 TEST INSTRUMENTS

FOR POWER OUTPUT MEASUREMENT

DESCRIPTION & MANUFACTURER	MODEL NO.	SERIAL NO.	CALIBRATED DATE	CALIBRATED UNTIL
Peak Power Meter	ML2495A	0824006	May 04, 2011	May 03, 2012
Power Sensor	MA2411B	0738172	May 03, 2011	May 02, 2012

Note:

1. The calibration interval of the above test instruments is 12 months and the calibrations are traceable to NML/ROC and NIST/USA.
2. Tested date : Feb. 17, 2012

FOR 26dB OCCUPIED BANDWIDTH

DESCRIPTION & MANUFACTURER	MODEL NO.	SERIAL NO.	CALIBRATED DATE	CALIBRATED UNTIL
Spectrum Analyzer	E4446A	MY48250254	July 12, 2011	July 11, 2012

Note:

1. The calibration interval of the above test instruments is 12 months and the calibrations are traceable to NML/ROC and NIST/USA.
2. Tested date : Feb. 17, 2012

4.3.3 TEST PROCEDURE

FOR POWER OUTPUT MEASUREMENT

An average power sensor was used on the output port of the EUT. A power meter was used to read the response of the average power sensor. Record the power level.

FOR 26dB OCCUPIED BANDWIDTH

- 1) Set RBW = approximately 1% of the emission bandwidth.
- 2) Set the VBW > RBW.
- 3) Detector = Peak.
- 4) Trace mode = max hold.
- 5) Measure the maximum width of the emission that is 26 dB down from the peak of the emission. Compare this with the RBW setting of the analyzer. Readjust RBW and repeat measurement as needed until the RBW/EBW ratio is approximately 1%.

4.3.4 DEVIATION FROM TEST STANDARD

No deviation

4.3.5 TEST SETUP

FOR POWER OUTPUT MEASUREMENT

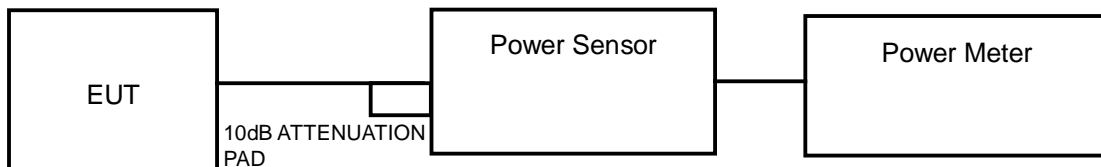

FOR 26dB OCCUPIED BANDWIDTH

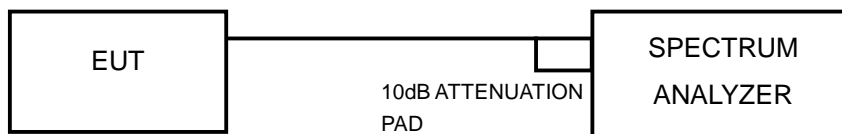

4.3.6 EUT OPERATING CONDITIONS

The software provided by client to enable the EUT under transmission condition continuously at specific channel frequencies individually.



A D T

4.3.7 TEST RESULTS

POWER OUTPUT: 802.11a

CHAN.	CHAN. FREQ. (MHz)	AVERAGE POWER (dBm)		TOTAL POWER (mW)	TOTAL POWER (dBm)	POWER LIMIT (dBm)	PASS / FAIL
		CHAIN 0	CHAIN 1				
36	5180	11.1	10.8	24.9	14.0	14.99	PASS
40	5200	11.0	11.5	26.7	14.3	14.99	PASS
48	5240	10.4	12.4	28.3	14.5	14.99	PASS

Note: Directional gain = gain of antenna element + 10 log (# of TX antenna elements)

Effective Legacy Gain (dBi) = 8.01

The effective legacy gain is 8.01dBi, therefore the limit needs to reduce.

802.11n (20MHz)

CHAN.	CHAN. FREQ. (MHz)	AVERAGE POWER (dBm)		TOTAL POWER (mW)	TOTAL POWER (dBm)	POWER LIMIT (dBm)	PASS / FAIL
		CHAIN 0	CHAIN 1				
36	5180	11.0	10.6	24.1	13.8	17	PASS
40	5200	12.1	12.8	35.3	15.5	17	PASS
48	5240	12.5	14.5	46.0	16.6	17	PASS

802.11n (40MHz)

CHAN.	CHAN. FREQ. (MHz)	AVERAGE POWER (dBm)		TOTAL POWER (mW)	TOTAL POWER (dBm)	POWER LIMIT (dBm)	PASS / FAIL
		CHAIN 0	CHAIN 1				
38	5190	10.6	10.0	21.5	13.3	17	PASS
46	5230	13.1	14.4	48.0	16.8	17	PASS



A D T

26dB BANDWIDTH:

802.11a

CHANNEL	CHANNEL FREQUENCY (MHz)	26dBc BANDWIDTH (MHz)		PASS / FAIL
		CHAIN 0	CHAIN 1	
36	5180	24.95	24.48	PASS
40	5200	25.65	24.00	PASS
48	5240	24.79	23.80	PASS

802.11n (20MHz)

CHANNEL	CHANNEL FREQUENCY (MHz)	26dBc BANDWIDTH (MHz)		PASS / FAIL
		CHAIN 0	CHAIN 1	
36	5180	25.91	25.80	PASS
40	5200	25.95	26.05	PASS
48	5240	25.86	26.88	PASS

802.11n (40MHz)

CHANNEL	CHANNEL FREQUENCY (MHz)	26dBc BANDWIDTH (MHz)		PASS / FAIL
		CHAIN 0	CHAIN 1	
38	5190	54.11	54.65	PASS
46	5230	54.83	65.68	PASS

4.4 PEAK POWER SPECTRAL DENSITY MEASUREMENT

4.4.1 LIMITS OF PEAK POWER SPECTRAL DENSITY MEASUREMENT

Frequency Band	Limit
5.15 ~ 5.25GHz	4dBm
5.25 ~ 5.35GHz	11dBm
5.47 – 5.725GHz	11dBm
5.725 ~ 5.825GHz	17dBm

4.4.2 TEST INSTRUMENTS

DESCRIPTION & MANUFACTURER	MODEL NO.	SERIAL NO.	CALIBRATED DATE	CALIBRATED UNTIL
Spectrum Analyzer	E4446A	MY48250254	July 12, 2011	July 11, 2012

Note:

1. The calibration interval of the above test instruments is 12 months and the calibrations are traceable to NML/ROC and NIST/USA.
2. Tested date : Feb. 17, 2012

4.4.3 TEST PROCEDURES

- 1) Set span to encompass the entire emission bandwidth (EBW) of the signal.
- 2) Set RBW = 1 MHz, Set VBW \geq 3 MHz, Detector = RMS
- 3) Sweep time = auto, trigger set to “free run”.
- 4) Trace average at least 100 traces in power averaging mode.
- 5) Record the max value

4.4.4 DEVIATION FROM TEST STANDARD

No deviation



A D T

4.4.5 TEST SETUP

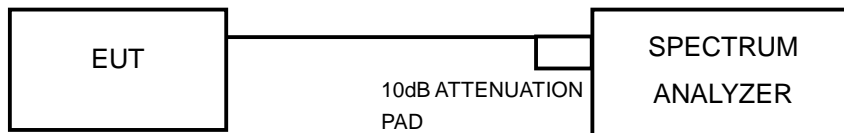

4.4.6 EUT OPERATING CONDITIONS

Same as 4.3.6



4.4.7 TEST RESULTS

802.11a

CHAN.	CHAN. FREQ. (MHz)	PSD (dBm)		TOTAL POWER DENSITY (dBm)	MAX. LIMIT (dBm)	PASS / FAIL
		CHAIN 0	CHAIN 1			
36	5180	-1.1	-0.8	1.7	1.99	PASS
40	5200	-1.4	-0.4	1.8	1.99	PASS
48	5240	-2.2	-0.1	1.8	1.99	PASS

NOTE: 1. Method 1 of power density measurement of KDB 662911 is using for calculating total power density. Total power density is summing entire spectra across corresponding frequency bins on the various outputs by computer.

2. Directional gain = gain of antenna element + 10 log (# of TX antenna elements)

Effective Legacy Gain (dBi) = 8.01

The effective legacy gain is 8.01dBi, therefore the limit needs to reduce.

802.11n (20MHz)

CHAN.	CHAN. FREQ. (MHz)	PSD (dBm)		TOTAL POWER DENSITY (dBm)	MAX. LIMIT (dBm)	PASS / FAIL
		CHAIN 0	CHAIN 1			
36	5180	-1.0	-1.5	1.5	4	PASS
40	5200	-0.2	1.0	2.9	4	PASS
48	5240	-0.1	2.1	3.8	4	PASS

NOTE: Method 1 of power density measurement of KDB 662911 is using for calculating total power density. Total power density is summing entire spectra across corresponding frequency bins on the various outputs by computer.

802.11n (40MHz)

CHAN.	CHAN. FREQ. (MHz)	PSD (dBm)		TOTAL POWER DENSITY (dBm)	MAX. LIMIT (dBm)	PASS / FAIL
		CHAIN 0	CHAIN 1			
38	5190	-4.6	-4.5	-1.8	4	PASS
46	5230	-1.5	-0.6	2.0	4	PASS

NOTE: Method 1 of power density measurement of KDB 662911 is using for calculating total power density. Total power density is summing entire spectra across corresponding frequency bins on the various outputs by computer.

4.5 PEAK POWER EXCURSION MEASUREMENT

4.5.1 LIMITS OF PEAK POWER EXCURSION MEASUREMENT

Shall not exceed 13 dB

4.5.2 TEST INSTRUMENTS

DESCRIPTION & MANUFACTURER	MODEL NO.	SERIAL NO.	CALIBRATED DATE	CALIBRATED UNTIL
Spectrum Analyzer	E4446A	MY48250254	July 12, 2011	July 11, 2012

Note:

1. The calibration interval of the above test instruments is 12 months and the calibrations are traceable to NML/ROC and NIST/USA.
2. Tested date : Feb. 17, 2012

4.5.3 TEST PROCEDURE

- 1) Set RBW = 1 MHz, VBW \leq 3 MHz, Detector = peak.
- 2) Trace mode = max-hold. Allow the sweeps to continue until the trace stabilizes.
- 3) Use the peak search function to find the peak of the spectrum.
- 4) Measure the PPSD.
- 5) Compute the ratio of the maximum of the peak-max-hold spectrum to the PPSD.

4.5.4 DEVIATION FROM TEST STANDARD

No deviation

4.5.5 TEST SETUP

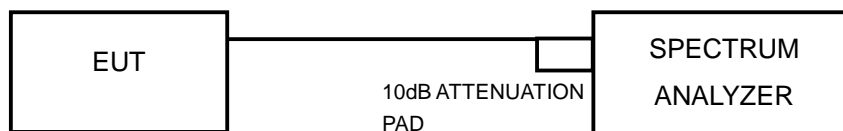

4.5.6 EUT OPERATING CONDITIONS

The software provided by client to enable the EUT under transmission condition continuously at specific channel frequencies individually.



A D T

4.5.7 TEST RESULTS

802.11a

TX chain	CHAN.	CHANNEL FREQUENCY (MHz)	PEAK VALUE (dBm)	PPSD (dBm)	PEAK EXCURSION (dB)	LIMIT (dB)	PASS /FAIL
0	36	5180	9.97	-1.1	11.0	13	PASS
	40	5200	9.49	-1.4	10.8	13	PASS
	48	5240	8.37	-2.2	10.6	13	PASS
1	36	5180	10.63	-0.8	11.4	13	PASS
	40	5200	11.62	-0.4	12.0	13	PASS
	48	5240	12.16	-0.1	12.2	13	PASS



A D T

Chain 0 : CH 36

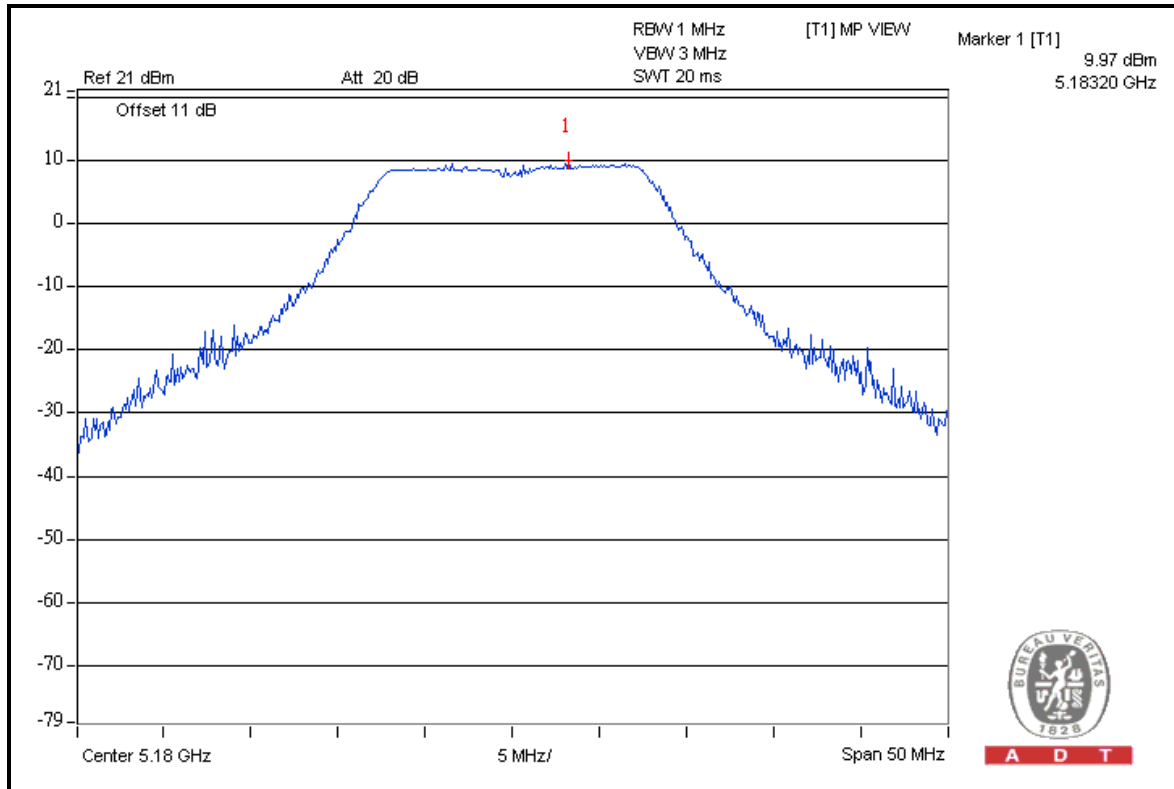

Chain 1 : CH 48

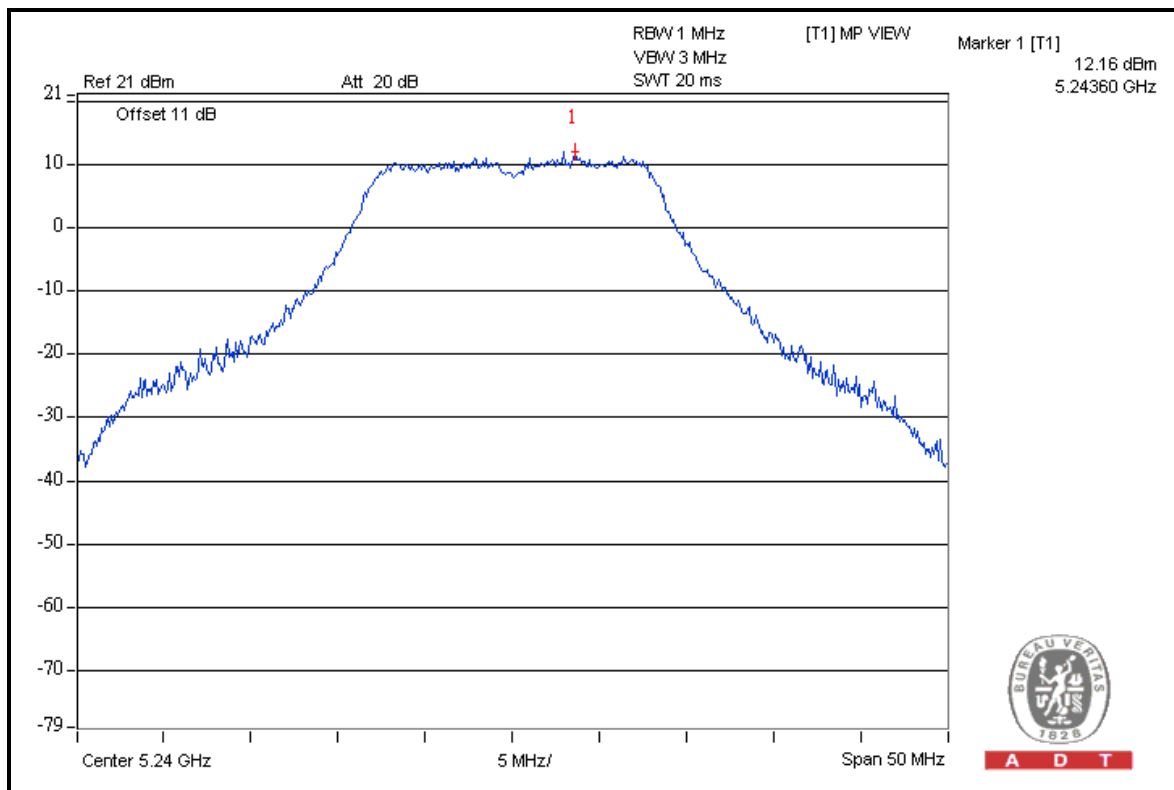



A D T

802.11n (20MHz)

TX chain	CHAN.	CHANNEL FREQUENCY (MHz)	PEAK VALUE (dBm)	PPSD (dBm)	PEAK EXCURSION (dB)	LIMIT (dB)	PASS /FAIL
0	36	5180	9.45	-1.0	10.5	13	PASS
	40	5200	10.22	-0.2	10.4	13	PASS
	48	5240	11.07	-0.1	11.2	13	PASS
1	36	5180	9.49	-1.5	11.0	13	PASS
	40	5200	11.73	1.0	10.8	13	PASS
	48	5240	12.77	2.1	10.6	13	PASS



A D T

Chain 0 : CH 48

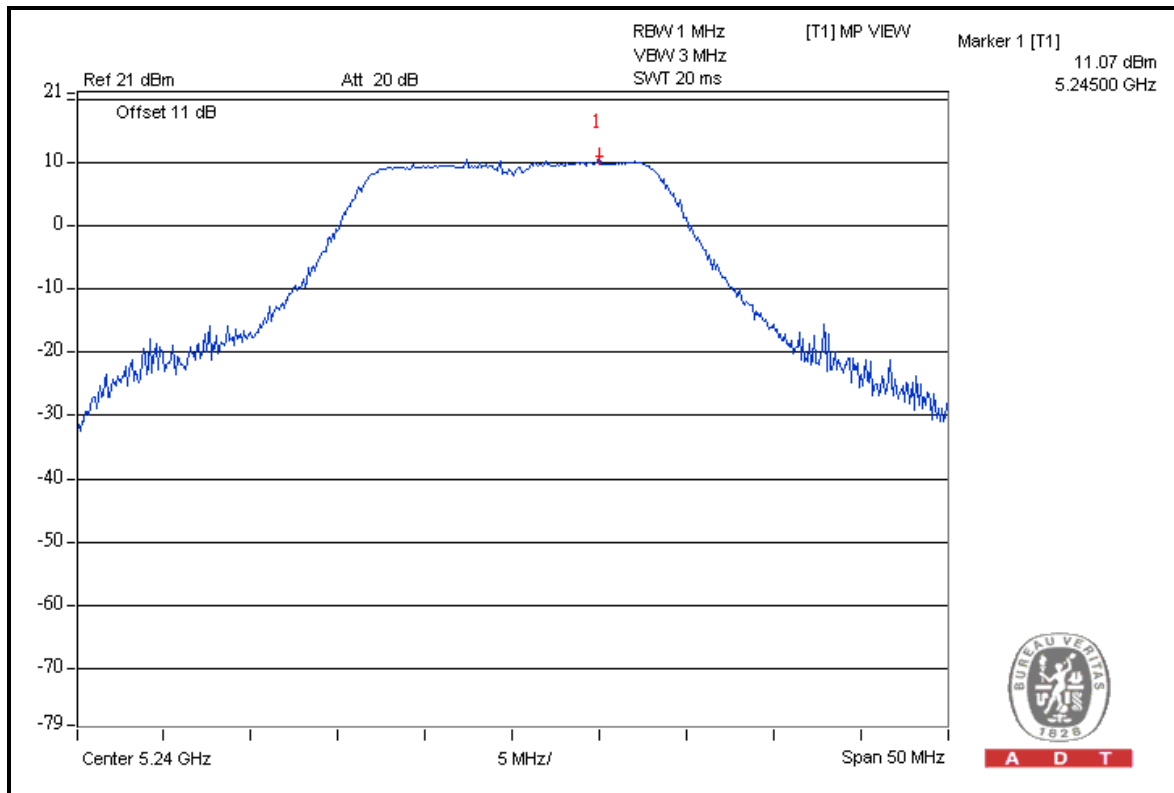

Chain 1 : CH 48

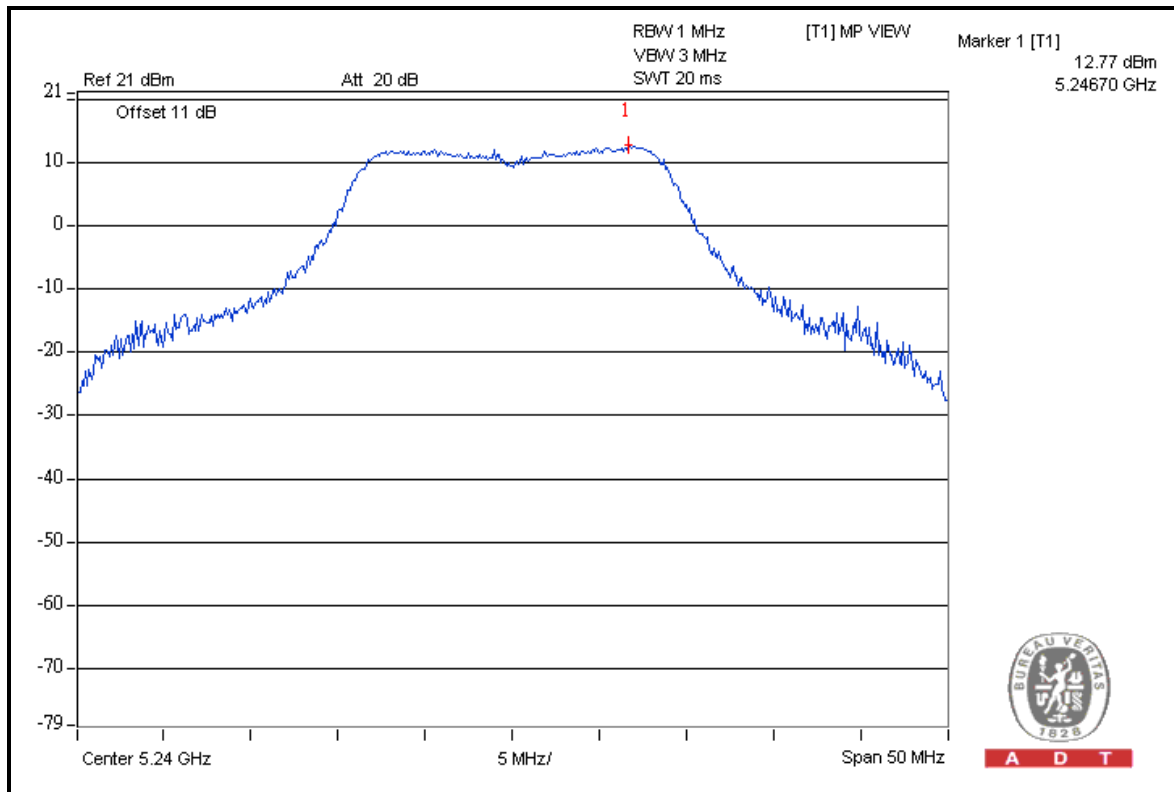



A D T

802.11n (40MHz)

TX chain	CHAN.	CHANNEL FREQUENCY (MHz)	PEAK VALUE (dBm)	PPSD (dBm)	PEAK EXCURSION (dB)	LIMIT (dB)	PASS /FAIL
0	38	5190	6.07	-4.6	10.7	13	PASS
	46	5230	8.90	-1.5	10.4	13	PASS
1	38	5190	6.57	-4.5	11.1	13	PASS
	46	5230	10.23	-0.6	10.8	13	PASS



A D T

Chain 0 : CH 46

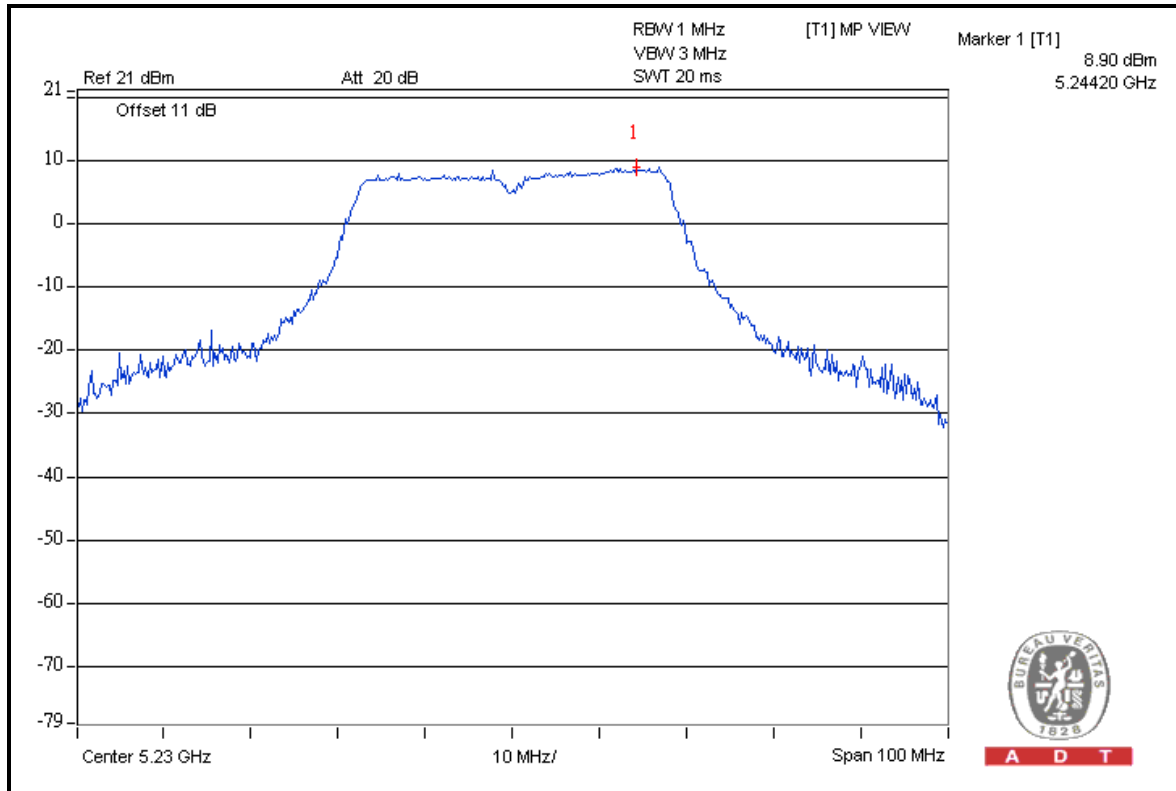

Chain 1 : CH 46

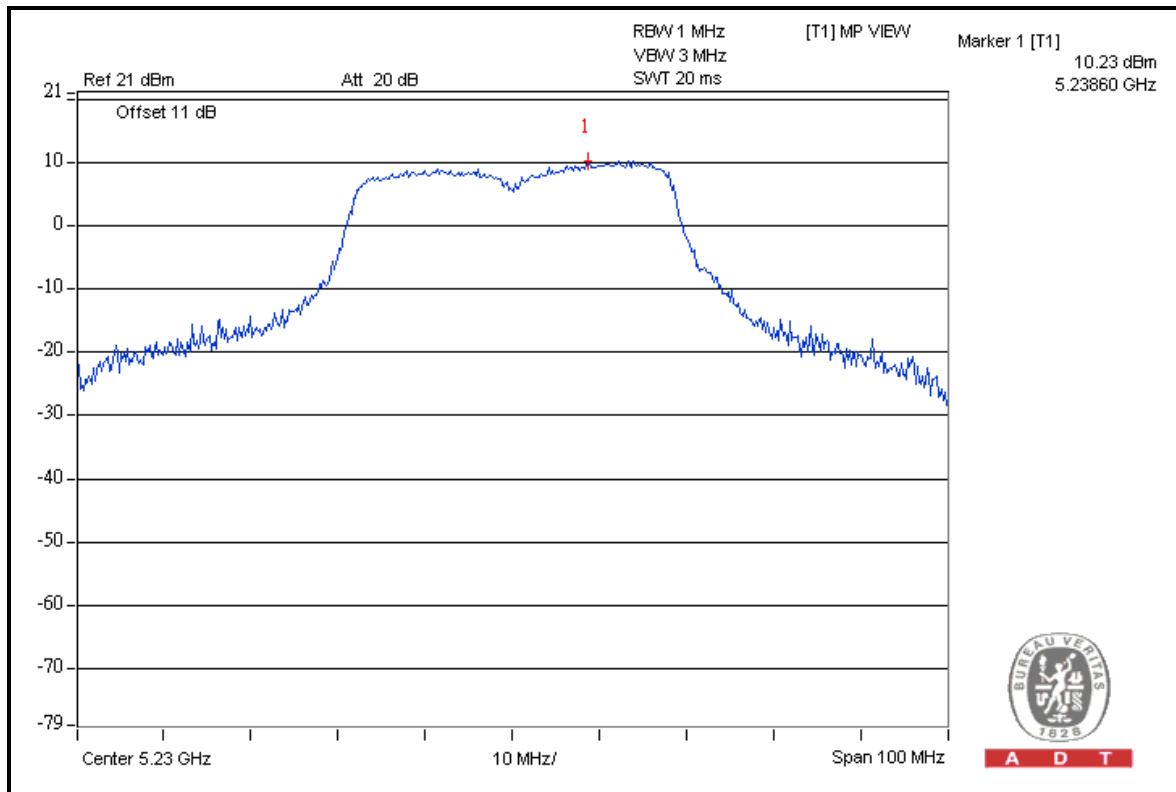



A D T

4.6 FREQUENCY STABILITY

4.6.1 LIMITS OF FREQUENCY STABILITY MEASUREMENT

The frequency of the carrier signal shall be maintained within band of operation

4.6.2 TEST INSTRUMENTS

DESCRIPTION & MANUFACTURER	MODEL NO.	SERIAL NO.	CALIBRATED DATE	CALIBRATED UNTIL
R&S Spectrum Analyzer	FSP 40	100060	May 11, 2011	May 10, 2012

Note:

1. The calibration interval of the above test instruments is 12 months and the calibrations are traceable to NML/ROC and NIST/USA.
2. Tested date : Feb. 17, 2012

4.6.3 TEST PROCEDURE

1. The EUT was placed inside the environmental test chamber and powered by nominal AC voltage.
2. Turn the EUT on and couple its output to a spectrum analyzer.
3. Turn the EUT off and set the chamber to the highest temperature specified.
4. Allow sufficient time (approximately 30 min) for the temperature of the chamber to stabilize, turn the EUT on and measure the operating frequency after 2, 5, and 10 minutes.
5. Repeat step 2 and 3 with the temperature chamber set to the lowest temperature.
6. The test chamber was allowed to stabilize at +20 degree C for a minimum of 30 minutes. The supply voltage was then adjusted on the EUT from 85% to 115% and the frequency record.

4.6.4 DEVIATION FROM TEST STANDARD

No deviation

4.6.5 TEST SETUP

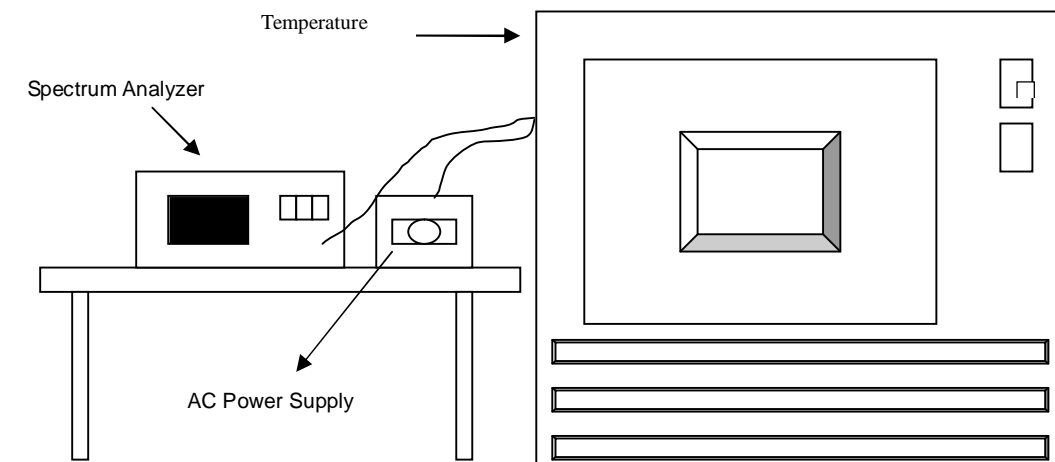

4.6.6 EUT OPERATING CONDITION

Set the EUT transmit at un-modulation mode to test frequency stability.



A D T

4.6.7 TEST RESULTS

FREQUENCY STABILITY VERSUS TEMP.									
OPERATING FREQUENCY: 5240MHz									
TEMP. (°C)	POWER SUPPLY (Vac)	0 MINUTE		2 MINUTE		5 MINUTE		10 MINUTE	
		Measured Frequency	Frequency Drift	Measured Frequency	Frequency Drift	Measured Frequency	Frequency Drift	Measured Frequency	Frequency Drift
		(MHz)	ppm	(MHz)	ppm	(MHz)	ppm	(MHz)	ppm
50	120	5239.9815	-3.5305	5239.9825	-3.3397	5239.9816	-3.5115	5239.985	-2.8626
40	120	5239.9825	-3.3397	5239.9814	-3.5496	5239.9862	-2.6336	5239.9886	-2.1756
30	120	5240.0089	1.6985	5240.0116	2.2137	5240.016	3.0534	5240.0147	2.8053
20	120	5240.0039	0.7443	5240.0001	0.0191	5239.9989	-0.2099	5240.0034	0.6489
10	120	5239.9916	-1.6031	5239.9941	-1.1260	5239.9885	-2.1947	5239.9919	-1.5458
0	120	5240.0096	1.8321	5240.0129	2.4618	5240.0079	1.5076	5240.0107	2.0420
-10	120	5240.0051	0.9733	5240.001	0.1908	5240.0002	0.0382	5240.0001	0.0191
-20	120	5240.0144	2.7481	5240.0154	2.9389	5240.0109	2.0802	5240.0053	1.0115
-30	120	5239.9956	-0.8397	5239.9924	-1.4504	5239.9886	-2.1756	5239.9852	-2.8244

FREQUENCY STABILITY VERSUS VOLTAGE									
OPERATING FREQUENCY: 5240MHz									
TEMP. (°C)	POWER SUPPLY (Vac)	0 MINUTE		2 MINUTE		5 MINUTE		10 MINUTE	
		Measured Frequency	Frequency Drift	Measured Frequency	Frequency Drift	Measured Frequency	Frequency Drift	Measured Frequency	Frequency Drift
		(MHz)	ppm	(MHz)	ppm	(MHz)	ppm	(MHz)	ppm
20	138	5240.0038	0.7252	5239.999	-0.1908	5239.9993	-0.1336	5240.0029	0.5534
	120	5240.0039	0.7443	5240.0001	0.0191	5239.9989	-0.2099	5240.0034	0.6489
	102	5240.0035	0.6679	5240.0005	0.0954	5239.9995	-0.0954	5240.0033	0.6298



A D T

5. PHOTOGRAPHS OF THE TEST CONFIGURATION

Please refer to the attached file (Test Setup Photo).



6. INFORMATION ON THE TESTING LABORATORIES

We, Bureau Veritas Consumer Products Services (H.K.) Ltd., Taoyuan Branch, were founded in 1988 to provide our best service in EMC, Radio, Telecom and Safety consultation. Our laboratories are accredited and approved according to ISO/IEC 17025.

Copies of accreditation and authorization certificates of our laboratories obtained from approval agencies can be downloaded from our web site:

www.adt.com.tw/index.5.phtml.

If you have any comments, please feel free to contact us at the following:

Linko EMC/RF Lab:

Tel: 886-2-26052180

Fax: 886-2-26052943

Hsin Chu EMC/RF Lab:

Tel: 886-3-5935343

Fax: 886-3-5935342

Hwa Ya EMC/RF/Safety/Telecom Lab:

Tel: 886-3-3183232

Fax: 886-3-3185050

Email: service.adt@tw.bureauveritas.com

Web Site: www.adt.com.tw

The address and road map of all our labs can be found in our web site also.



A D T

7.APPENDIX A - MODIFICATIONS RECORDERS FOR ENGINEERING CHANGES TO THE EUT BY THE LAB

No modifications were made to the EUT by the lab during the test.

--- END ---