



FCC RADIO TEST REPORT

FCC ID: RRJ-Q10

Product : SMART TV BOX

Trade Name : N/A

Model Name : Q10

Serial Model : N/A

Report No. : NTEK- 2013NT0125147F

Prepared for

Shenzhen HiMedia Technology Limited
Room B302, Zondy Cyber, Cyber-tech Zone, Keyuan Road(South),
Nanshan District, Shenzhen, China

Prepared by

Shenzhen NTEK Testing Technology Co., Ltd.
1/F, Building E, Fenda Science Park, Sanwei Community, Xixiang Street
Bao'an District, Shenzhen P.R. China
Tel.: +86-0755-61156588 Fax.: +86-0755-61156599
Website: www.ntek.org.cn

TEST RESULT CERTIFICATION

Applicant's name : Shenzhen HiMedia Technology Limited
Address : Room B302, Zondy Cyber, Cyber-tech Zone, Keyuan Road(South), Nanshan District, Shenzhen, China

Manufacture's Name..... : Shenzhen HiMedia Technology Limited
Address : Room B302, Zondy Cyber, Cyber-tech Zone, Keyuan Road(South), Nanshan District, Shenzhen, China

Product description

Product name : SMART TV BOX
Model and/or type reference : Q10
Serial Model : N/A

Standards : FCC Part15.247

Test procedure ANSI C63.4-2003

This device described above has been tested by NTEK, and the test results show that the equipment under test (EUT) is in compliance with the FCC requirements. And it is applicable only to the tested sample identified in the report.

This report shall not be reproduced except in full, without the written approval of NTEK, this document may be altered or revised by NTEK, personal only, and shall be noted in the revision of the document.

Date of Test :

Date (s) of performance of tests : 14 Jan. 2013 ~30 Jan. 2013

Date of Issue..... : 31 Jan. 2013

Test Result..... : **Pass**

Testing Engineer : Apple Huang
(Apple Huang)

Technical Manager : Tom Zhang
(Tom Zhang)

Authorized Signatory : Bovey Yang
(Bovey Yang)

Table of Contents

	Page
1 . SUMMARY OF TEST RESULTS	5
1.1 TEST FACILITY	6
1.2 MEASUREMENT UNCERTAINTY	6
2 . GENERAL INFORMATION	7
2.1 GENERAL DESCRIPTION OF EUT	7
2.2 DESCRIPTION OF TEST MODES	9
2.3 BLOCK DIGRAM SHOWING THE CONFIGURATION OF SYSTEM TESTED	10
2.4 DESCRIPTION OF SUPPORT UNITS(CONDUCTED MODE)	11
2.5 EQUIPMENTS LIST FOR ALL TEST ITEMS	12
3 . EMC EMISSION TEST	13
3.1 CONDUCTED EMISSION MEASUREMENT	13
3.1.1 POWER LINE CONDUCTED EMISSION LIMITS	13
3.1.2 TEST PROCEDURE	14
3.1.3 DEVIATION FROM TEST STANDARD	14
3.1.4 TEST SETUP	14
3.1.5 EUT OPERATING CONDITIONS	14
3.1.6 TEST RESULTS	15
3.2 RADIATED EMISSION MEASUREMENT	19
3.2.1 RADIATED EMISSION LIMITS	19
3.2.2 TEST PROCEDURE	20
3.2.3 DEVIATION FROM TEST STANDARD	20
3.2.4 TEST SETUP	21
3.2.5 EUT OPERATING CONDITIONS	22
3.2.6 TEST RESULTS (BETWEEN 9KHZ – 30 MHZ)	23
3.2.7 TEST RESULTS (BETWEEN 30MHZ – 1GHZ)	24
3.2.8 TEST RESULTS (ABOVE 1000 MHZ)	28
4 . POWER SPECTRAL DENSITY TEST	68
4.1 APPLIED PROCEDURES / LIMIT	68
4.1.1 TEST PROCEDURE	68
4.1.2 DEVIATION FROM STANDARD	68
4.1.3 TEST SETUP	68
4.1.4 EUT OPERATION CONDITIONS	68
4.1.5 TEST RESULTS	69
5 . BANDWIDTH TEST	77
5.1 APPLIED PROCEDURES / LIMIT	77
5.1.1 TEST PROCEDURE	77

Table of Contents

	Page
5.1.2 DEVIATION FROM STANDARD	77
5.1.3 TEST SETUP	77
5.1.4 EUT OPERATION CONDITIONS	77
5.1.5 TEST RESULTS	78
6 . PEAK OUTPUT POWER TEST	86
6.1 APPLIED PROCEDURES / LIMIT	86
6.1.1 TEST PROCEDURE	86
6.1.2 DEVIATION FROM STANDARD	86
6.1.3 TEST SETUP	86
6.1.4 EUT OPERATION CONDITIONS	86
6.1.5 TEST RESULTS	87
7 . ANTENNA REQUIREMENT	88
7.1 STANDARD REQUIREMENT	88
7.2 EUT ANTENNA	88
8 . EUT TEST PHOTO	89
APPENDIX-PHOTOGRAPHS OF EUT CONSTRUCTIONAL DETAILS	

1. SUMMARY OF TEST RESULTS

Test procedures according to the technical standards:

FCC Part15 (15.247) , Subpart C			
Standard Section	Test Item	Judgment	Remark
15.207	Conducted Emission	PASS	
15.247 (a)(2)	6dB Bandwidth	PASS	
15.247 (b)	Peak Output Power	PASS	
15.247 (c)	Radiated Spurious Emission	PASS	
15.247 (d)	Power Spectral Density	PASS	
15.205	Band Edge Emission	PASS	
15.203	Antenna Requirement	PASS	

NOTE:

(1) "N/A" denotes test is not applicable in this Test Report

1.1 TEST FACILITY

NTEK Testing Technology Co., Ltd
 Add.:1/F, Building E, Fenda Science Park, Sanwei Community, Xixiang Street, Bao'an District, Shenzhen P.R. China.
 FCC Registration No.:238937; IC Registration No.:9270A-1
 CNAS Registration No.:L5516

1.2 MEASUREMENT UNCERTAINTY

The reported uncertainty of measurement $y \pm U$, where expanded uncertainty U is based on a standard uncertainty multiplied by a coverage factor of $k=2$, providing a level of confidence of approximately 95 %.

No.	Item	Uncertainty
1	Conducted Emission Test	$\pm 1.38\text{dB}$
2	RF power,conducted	$\pm 0.16\text{dB}$
3	Spurious emissions,conducted	$\pm 0.21\text{dB}$
4	All emissions,radiated(<1G)	$\pm 4.68\text{dB}$
5	All emissions,radiated(>1G)	$\pm 4.89\text{dB}$
6	Temperature	$\pm 0.5^\circ\text{C}$
7	Humidity	$\pm 2\%$

2. GENERAL INFORMATION

2.1 GENERAL DESCRIPTION OF EUT

Equipment	SMART TV BOX	
Trade Name	N/A	
Model Name	Q10	
Serial Model	N/A	
Model Difference	N/A	
Product Description	The EUT is a SMART TV BOX	
	Operation Frequency:	802.11b/g/n:2412~2462 MHz
	Modulation Type:	CCK/OFDM/DBPSK/DAPSK
	Bit Rate of Transmitter	802.11b:11/5.5/2/1 Mbps 802.11g:54/48/36/24/18/12/9/6 Mbps 802.11n(20/40MHz):150/144.44/130/117/115.56/104/86.67/78/52/6.5 Mbps
	Number Of Channel	802.11b/g/n20: 11CH 802.11n40: 7CH
	Antenna Designation:	Please see Note 3.
	Output Power(Conducted):	802.11b: 15.88 dBm (Max.) 802.11g: 14.79 dBm (Max.) 802.11n20: 13.76 dBm (Max.) 802.11n40: 12.87 dBm (Max.)
	Antenna Gain (dBi)	2.0dbi
Based on the application, features, or specification exhibited in User's Manual, the EUT is considered as an ITE/Computing Device. More details of EUT technical specification, please refer to the User's Manual.		
Channel List	Please refer to the Note 2.	
Ratings	DC 12V from adapter AC 120V/60Hz	
Adapter	Adapter1	Adapter2
	Model: HK40-HASF1202000 Input:100~240V, 50/60Hz, 1A Output:DC 12V, 2.0A	Input:100~240V,50/60Hz,0.75A Output:DC 12V, 2.0A
Battery	N/A	
Connecting I/O Port(s)	Please refer to the User's Manual	

Note:

1. For a more detailed features description, please refer to the manufacturer's specifications or the User's Manual.

2.

Channel List for 802.11b/g/n(20MHz)							
Channel	Frequency (MHz)	Channel	Frequency (MHz)	Channel	Frequency (MHz)	Channel	Frequency (MHz)
01	2412	04	2427	07	2442	10	2457
02	2417	05	2432	08	2447	11	2462
03	2422	06	2437	09	2452		

Channel List for 802.11n(40MHz)							
Channel	Frequency (MHz)	Channel	Frequency (MHz)	Channel	Frequency (MHz)	Channel	Frequency (MHz)
03	2422	06	2437	09	2452		
04	2427	07	2442				
05	2432	08	2447				

3.

Table for Filed Antenna

Ant	Brand	Model Name	Antenna Type	Connector	Gain (dBi)	NOTE
A	N/A	N/A	external antenna	Reserve SMA-type	2.0	N/A

2.2 DESCRIPTION OF TEST MODES

To investigate the maximum EMI emission characteristics generates from EUT, the test system was pre-scanning tested base on the consideration of following EUT operation mode or test configuration mode which possible have effect on EMI emission level. Each of these EUT operation mode(s) or test configuration mode(s) mentioned above was evaluated respectively.

Pretest Mode	Description
Mode 1	802.11b CH1/ CH6/ CH11
Mode 2	802.11g CH1/ CH6/ CH11
Mode 3	802.11n(20)CH1/ CH6/ CH11
Mode 4	802.11n(40) CH3/ CH6/ CH9
Mode 5	Link Mode

For Conducted Emission	
Final Test Mode	Description
Mode 4	Link Mode

For Radiated Emission	
Final Test Mode	Description
Mode 1	802.11b CH1/ CH6/ CH11
Mode 2	802.11g CH1/ CH6/ CH11
Mode 3	802.11n(20)CH1/ CH6/ CH11
Mode 4	802.11n(40) CH3/ CH6/ CH9

Note:

- (1) The measurements are performed at the highest, middle, lowest available channels.
- (2) The measurements are performed at all Bit Rate of Transmitter, the worst data was reported

2.3 BLOCK DIGRAM SHOWING THE CONFIGURATION OF SYSTEM TESTED

Conducted Emission Test



Radiated Spurious Emission Test

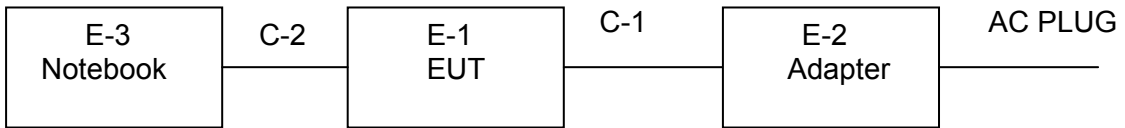

2.4 DESCRIPTION OF SUPPORT UNITS(CONDUCTED MODE)

The EUT has been tested as an independent unit together with other necessary accessories or support units. The following support units or accessories were used to form a representative test configuration during the tests.

Item	Equipment	Mfr/Brand	Model/Type No.	Series No.	Note
E-1	SMART TV BOX	N/A	Q10	N/A	EUT
E-2	Adapter	N/A	HK40-HASF1202000	N/A	
E-3	NOTEBOOK	IBM	2366	N/A	

Item	Shielded Type	Ferrite Core	Length	Note
C-1	NO	NO	0.8M	
C-2	NO	NO	0.8M	

Note:

- (1) The support equipment was authorized by Declaration of Confirmation.
- (2) For detachable type I/O cable should be specified the length in cm in 『Length』 column.

2.5 EQUIPMENTS LIST FOR ALL TEST ITEMS

Radiation Test equipment

Item	Kind of Equipment	Manufacturer	Type No.	Serial No.	Last calibration	Calibrated until	Calibration period
1	Spectrum Analyzer	Agilent	E4407B	MY45108040	2012.07.06	2013.07.05	1 year
2	Test Receiver	R&S	ESPI	101318	2012.06.07	2013.06.06	1 year
3	Bilog Antenna	TESEQ	CBL6111D	31216	2012.07.06	2013.07.05	1 year
4	50Ω Coaxial Switch	Anritsu	MP59B	6200264416	2012.06.07	2013.06.06	1 year
5	Spectrum Analyzer	ADVANTEST	R3132	150900201	2012.06.07	2013.06.06	1 year
6	Horn Antenna	EM	EM-AH-10180	2011071402	2012.07.06	2013.07.05	1 year
7	Horn Ant	Schwarzbeck	BBHA 9170	9170-181	2012.07.06	2013.07.05	1 year
8	Amplifier	EM	EM-30180	060538	2012.12.22	2013.12.21	1 year
9	Loop Antenna	ARA	PLA-1030/B	1029	2012.06.08	2013.06.07	1 year
10	Power Meter	R&S	NRVS	100696	2012.07.06	2013.07.05	1 year
11	Power Sensor	R&S	URV5-Z4	0395.1619.05	2012.07.06	2013.07.05	1 year

Conduction Test equipment

Item	Kind of Equipment	Manufacturer	Type No.	Serial No.	Last calibration	Calibrated until	Calibration period
1	Test Receiver	R&S	ESCI	101160	2012.06.06	2013.06.05	1 year
2	LISN	R&S	ENV216	101313	2012.08.24	2013.08.23	1 year
3	LISN	EMCO	3816/2	00042990	2012.08.24	2013.08.23	1 year
4	50Ω Coaxial Switch	Anritsu	MP59B	6200264417	2012.06.07	2013.06.06	1 year
5	Passive Voltage Probe	R&S	ESH2-Z3	100196	2012.06.07	2013.06.06	1 year
6	Absorbing clamp	R&S	MOS-21	100423	2012.06.08	2013.06.07	1 year

3. EMC EMISSION TEST

3.1 CONDUCTED EMISSION MEASUREMENT

3.1.1 POWER LINE CONDUCTED EMISSION Limits (Frequency Range 150KHz-30MHz)

FREQUENCY (MHz)	Class A (dBuV)		Class B (dBuV)		Standard
	Quasi-peak	Average	Quasi-peak	Average	
0.15 -0.5	79.00	66.00	66 - 56 *	56 - 46 *	CISPR
0.50 -5.0	73.00	60.00	56.00	46.00	CISPR
5.0 -30.0	73.00	60.00	60.00	50.00	CISPR

0.15 -0.5	79.00	66.00	66 - 56 *	56 - 46 *	FCC
0.50 -5.0	73.00	60.00	56.00	46.00	FCC
5.0 -30.0	73.00	60.00	60.00	50.00	FCC

Note:

- (1) The tighter limit applies at the band edges.
- (2) The limit of " * " marked band means the limitation decreases linearly with the logarithm of the frequency in the range.

The following table is the setting of the receiver

Receiver Parameters	Setting
Attenuation	10 dB
Start Frequency	0.15 MHz
Stop Frequency	30 MHz
IF Bandwidth	9 kHz

3.1.2 TEST PROCEDURE

- a. The EUT was placed 0.4 meters from the horizontal ground plane with EUT being connected to the power mains through a line impedance stabilization network (LISN). All other support equipments powered from additional LISN(s). The LISN provide 50 Ohm/ 50uH of coupling impedance for the measuring instrument.
- b. Interconnecting cables that hang closer than 40 cm to the ground plane shall be folded back and forth in the center forming a bundle 30 to 40 cm long.
- c. I/O cables that are not connected to a peripheral shall be bundled in the center. The end of the cable may be terminated, if required, using the correct terminating impedance. The overall length shall not exceed 1 m.
- d. LISN at least 80 cm from nearest part of EUT chassis.
- e. For the actual test configuration, please refer to the related Item –EUT Test Photos.

3.1.3 DEVIATION FROM TEST STANDARD

No deviation

3.1.4 TEST SETUP

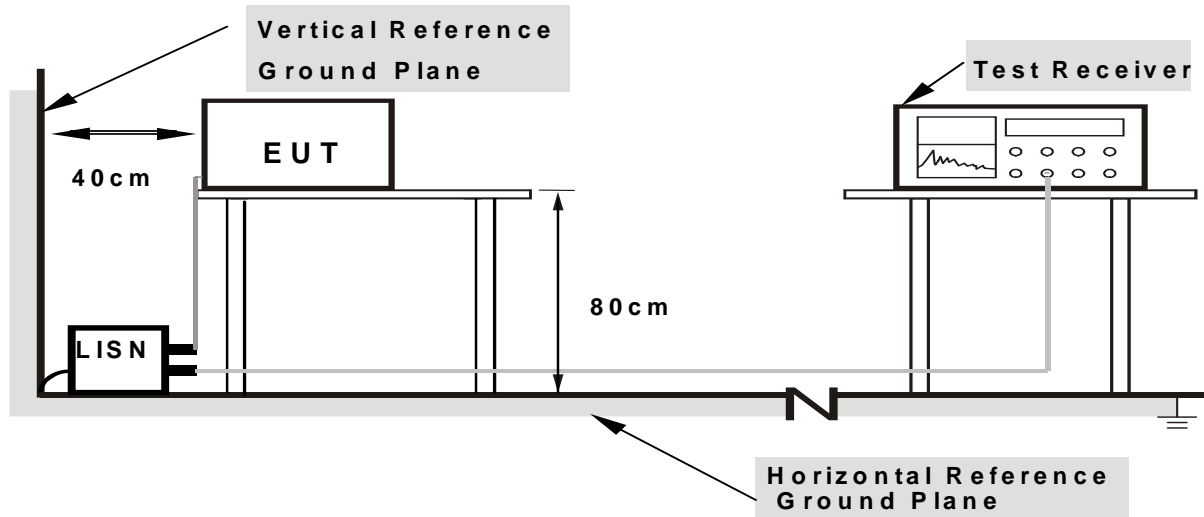

- Note:**
- 1. Support units were connected to second LISN.
 - 2. Both of LISNs (AMN) are 80 cm from EUT and at least 80 from other units and other metal planes

3.1.5 EUT OPERATING CONDITIONS

The EUT was configured for testing in a typical fashion (as a customer would normally use it). The EUT has been programmed to continuously transmit during test. This operating condition was tested and used to collect the included data.

3.1.6 TEST RESULTS

EUT :	SMART TV BOX	Model Name. :	Q10
Temperature :	26 °C	Relative Humidity :	54%
Pressure :	1010hPa	Phase :	L
Test Voltage :	DC 12V from adapter AC 120V/60Hz(adapter1)	Test Mode :	Mode 5

Frequency (MHz)	Meter Reading (dBμV)	Factor (dB)	Emission Level (dBμV)	Limits (dBμV)	Margin (dB)	Detector Type
0.286	45.8	10.2	56	60.64	-4.64	QP
0.29	32.35	10.2	42.55	50.52	-7.97	AVG
3.562	28.42	10.3	38.72	46	-7.28	AVG
4.3139	41.17	10.33	51.5	56	-4.5	QP
8.3939	26.81	10.33	37.14	50	-12.86	AVG
9.6699	41.95	10.33	52.28	60	-7.72	QP

Remark:

1. All readings are Quasi-Peak and Average values.
2. Factor = Insertion Loss + Cable Loss.

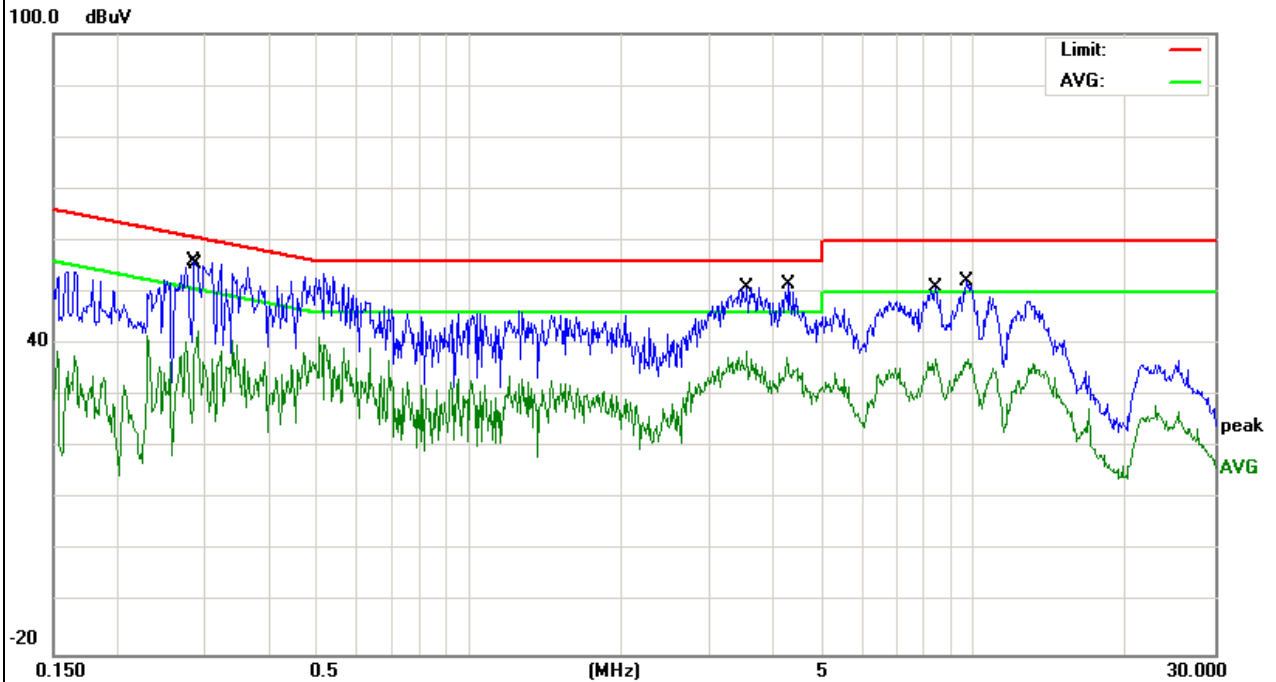

EUT :	SMART TV BOX	Model Name. :	Q10
Temperature :	26 °C	Relative Humidity :	54%
Pressure :	1010hPa	Phase :	N
Test Voltage :	DC 12V from adapter AC 120V/60Hz(adapter1)	Test Mode :	Mode 5

Frequency (MHz)	Meter Reading (dBμV)	Factor (dB)	Emission Level (dBμV)	Limits (dBμV)	Margin (dB)	Detector Type
0.286	32.35	9.89	42.24	50.64	-8.4	AVG
0.302	45.78	9.92	55.7	60.19	-4.49	QP
3.51	27.71	10.32	38.03	46	-7.97	AVG
3.726	43.34	10.32	53.66	56	-2.34	QP
9.7739	42.9	10.32	53.22	60	-6.78	QP
13.2979	27.92	10.42	38.34	50	-11.66	AVG

Remark:

1. All readings are Quasi-Peak and Average values.
2. Factor = Insertion Loss + Cable Loss.

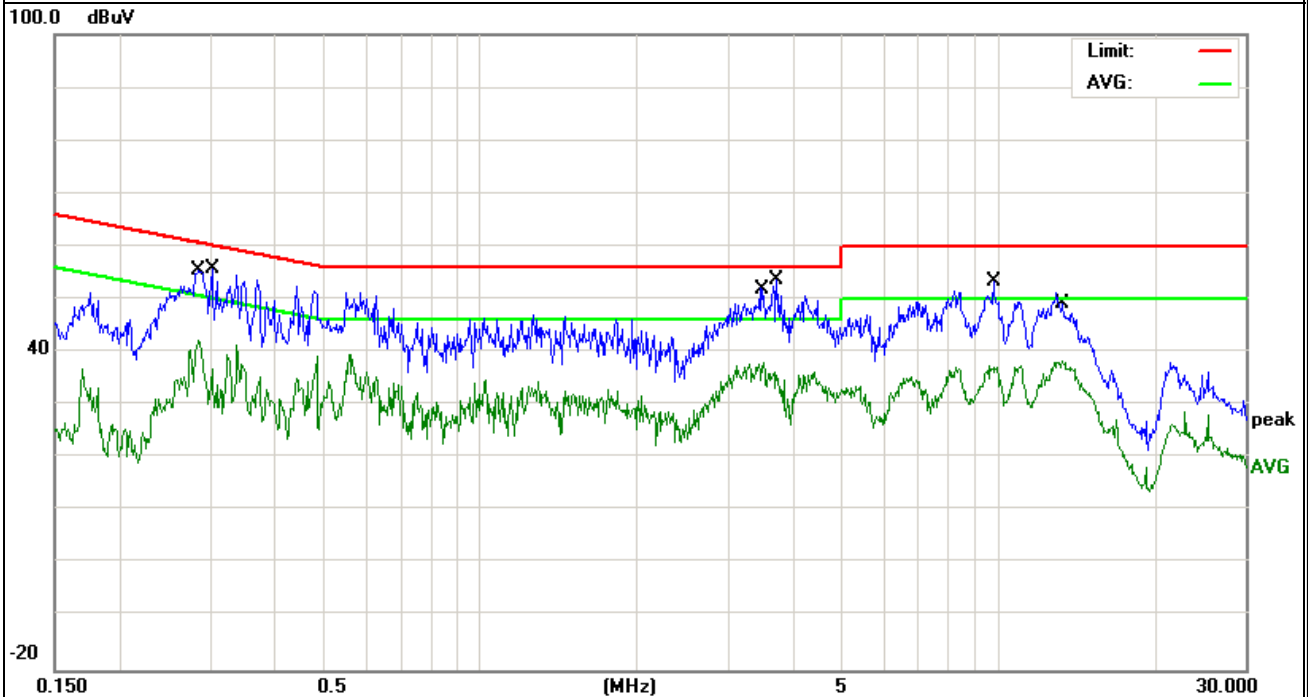

EUT :	SMART TV BOX	Model Name. :	Q10
Temperature :	26 °C	Relative Humidity :	54%
Pressure :	1010hPa	Phase :	L
Test Voltage :	DC 12V from adapter AC 120V/60Hz(adapter2)	Test Mode :	Mode 5

Frequency (MHz)	Meter Reading (dBμV)	Factor (dB)	Emission Level (dBμV)	Limits (dBμV)	Margin (dB)	Detector Type
0.4699	41.5	10.2	51.7	56.52	-4.82	QP
0.4939	28.67	10.2	38.87	46.1	-7.23	AVG
3.5779	25.63	10.3	35.93	46	-10.07	AVG
3.5859	38.6	10.3	48.9	56	-7.1	QP
9.4618	25	10.33	35.33	50	-14.67	AVG
9.5059	38.27	10.33	48.6	60	-11.4	QP

Remark:

1. All readings are Quasi-Peak and Average values.
2. Factor = Insertion Loss + Cable Loss.

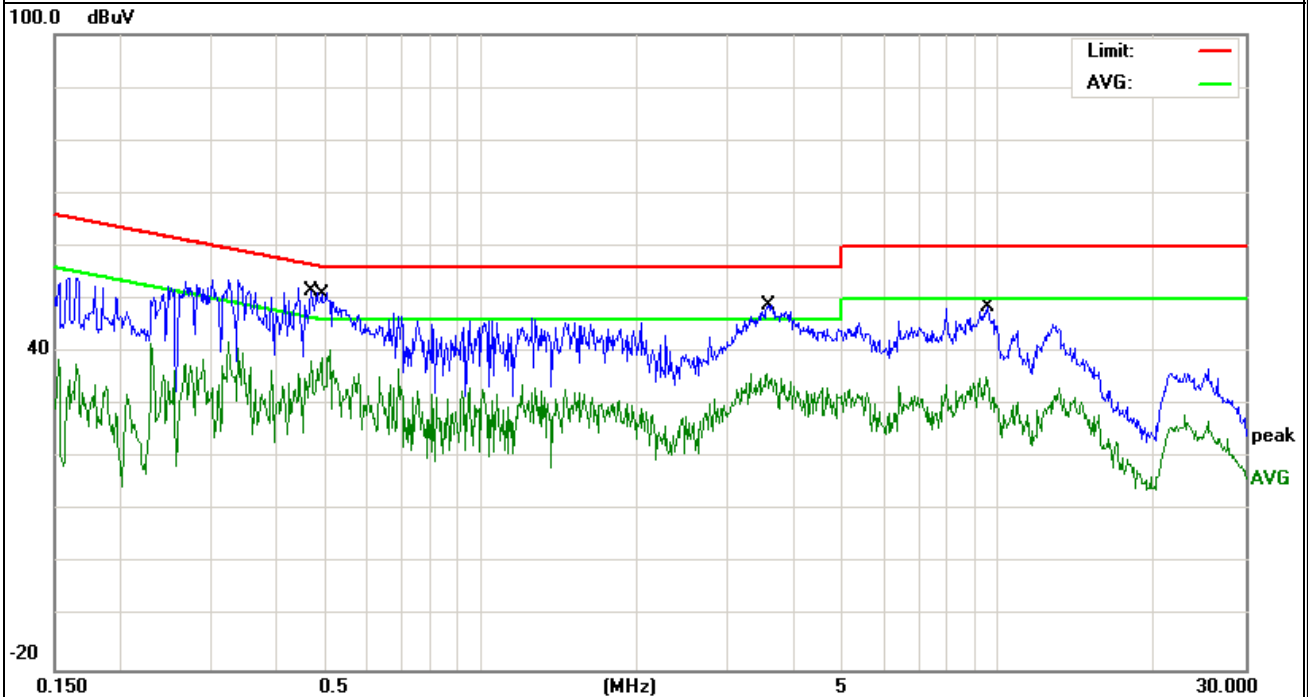

EUT :	SMART TV BOX	Model Name. :	Q10
Temperature :	26 °C	Relative Humidity :	54%
Pressure :	1010hPa	Phase :	N
Test Voltage :	DC 12V from adapter AC 120V/60Hz(adapter2)	Test Mode :	Mode 5

Frequency (MHz)	Meter Reading (dBμV)	Factor (dB)	Emission Level (dBμV)	Limits (dBμV)	Margin (dB)	Detector Type
0.266	42.74	9.86	52.6	61.24	-8.64	QP
0.274	29.09	9.88	38.97	50.99	-12.02	AVG
3.442	28.73	10.31	39.04	46	-6.96	AVG
3.466	39.49	10.31	49.8	56	-6.2	QP
8.2179	41.11	10.38	51.49	60	-8.51	QP
8.2738	26.8	10.38	37.18	50	-12.82	AVG

Remark:

1. All readings are Quasi-Peak and Average values.
2. Factor = Insertion Loss + Cable Loss.

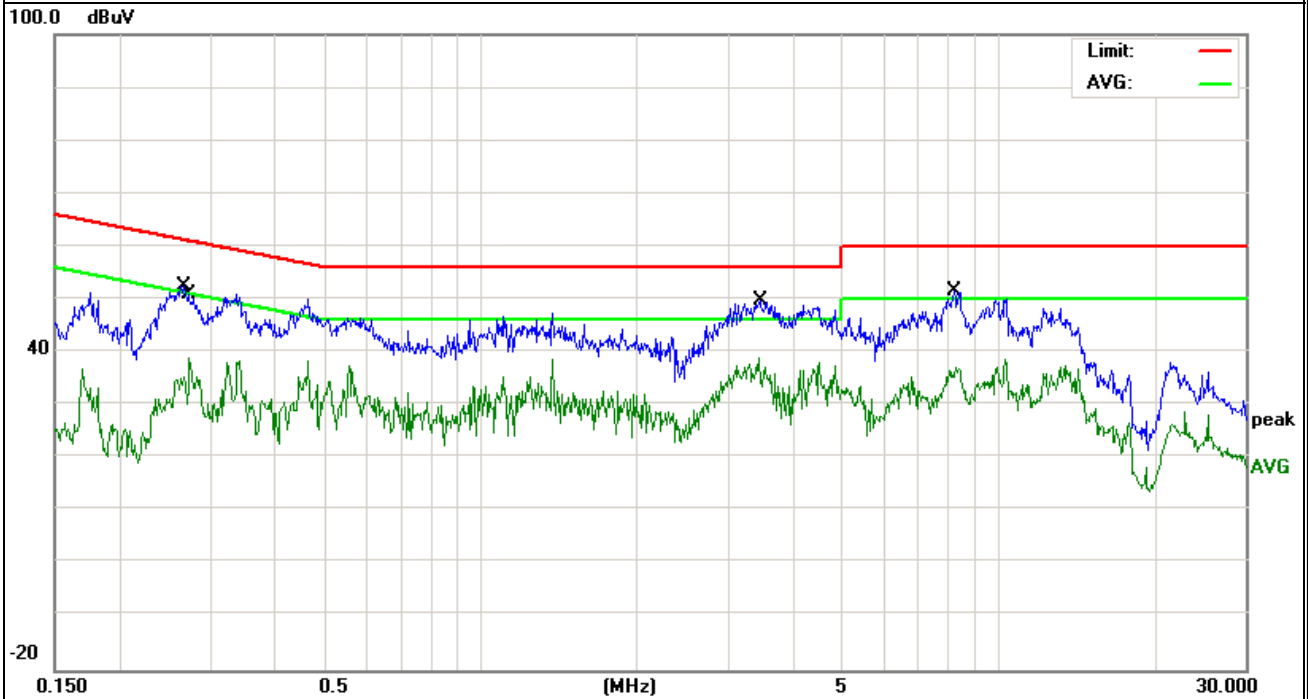

3.2 RADIATED EMISSION MEASUREMENT

3.2.1 RADIATED EMISSION LIMITS (Frequency Range 9kHz-1000MHz)

20dBc in any 100 kHz bandwidth outside the operating frequency band. In case the emission fall within the restricted band specified on 15.205(a), then the 15.209(a) limit in the table below has to be followed.

Frequencies (MHz)	Field Strength (microrvolts/meter)	Measurement Distance (meters)
0.009~0.490	2400/F(KHz)	300
0.490~1.705	24000/F(KHz)	30
1.705~30.0	30	30
30~88	100	3
88~216	150	3
216~960	200	3
Above 960	500	3

LIMITS OF RADIATED EMISSION MEASUREMENT (Above 1000MHz)

FREQUENCY (MHz)	Class A (dBuV/m) (at 3M)		Class B (dBuV/m) (at 3M)	
	PEAK	AVERAGE	PEAK	AVERAGE
Above 1000	80	60	74	54

Notes:

- (1) The limit for radiated test was performed according to FCC PART 15C.
- (2) The tighter limit applies at the band edges.
- (3) Emission level (dBuV/m)=20log Emission level (uV/m).

Spectrum Parameter	Setting
Attenuation	Auto
Start Frequency	1000 MHz
Stop Frequency	10th carrier harmonic
RB / VB (emission in restricted band)	1 MHz / 1 MHz for Peak, 1 MHz / 10Hz for Average

Receiver Parameter	Setting
Attenuation	Auto
Start ~ Stop Frequency	9kHz~150kHz / RB 200Hz for QP
Start ~ Stop Frequency	150kHz~30MHz / RB 9kHz for QP
Start ~ Stop Frequency	30MHz~1000MHz / RB 120kHz for QP

3.2.2 TEST PROCEDURE

- a. The measuring distance of at 3 m shall be used for measurements at frequency up to 1GHz. For frequencies above 1GHz, any suitable measuring distance may be used.
- b. The EUT was placed on the top of a rotating table 0.8 meters above the ground at a 3 meter open area test site. The table was rotated 360 degrees to determine the position of the highest radiation.
- c. The height of the equipment or of the substitution antenna shall be 0.8 m; the height of the test antenna shall vary between 1 m to 4 m. Both horizontal and vertical polarizations of the antenna are set to make the measurement.
- d. The initial step in collecting conducted emission data is a spectrum analyzer peak detector mode pre-scanning the measurement frequency range. Significant peaks are then marked and then Quasi Peak detector mode re-measured.
- e. If the Peak Mode measured value compliance with and lower than Quasi Peak Mode Limit, the EUT shall be deemed to meet QP Limits and then no additional QP Mode measurement performed.
- f. For the actual test configuration, please refer to the related Item –EUT Test Photos.

Note:

Both horizontal and vertical antenna polarities were tested and performed pretest to three orthogonal axis. The worst case emissions were reported

3.2.3 DEVIATION FROM TEST STANDARD

No deviation

3.2.4 TEST SETUP

(A) Radiated Emission Test-Up Frequency Below 30MHz

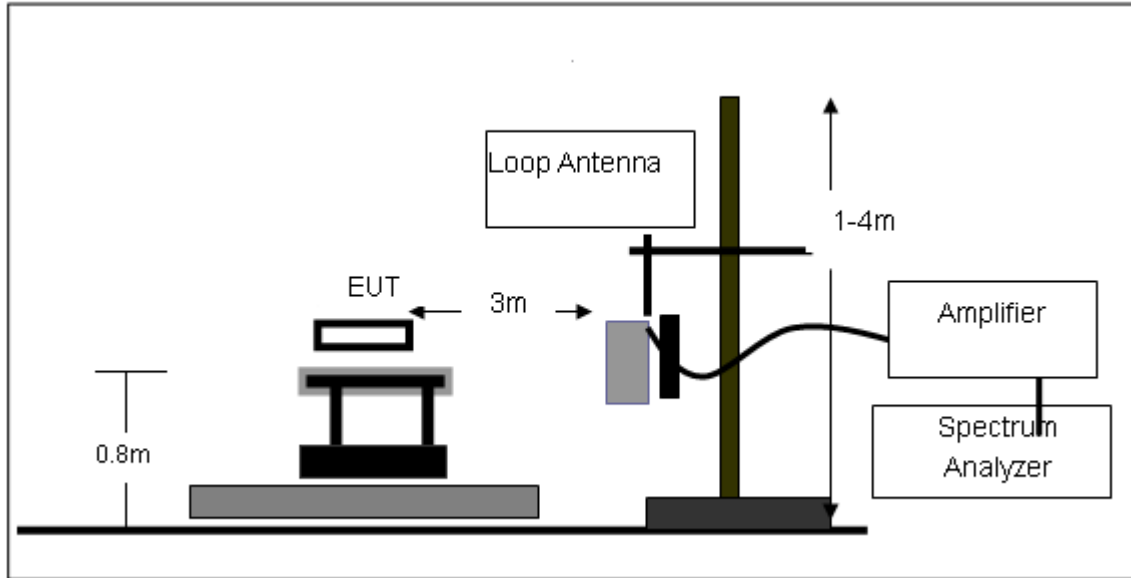

(B) Radiated Emission Test-Up Frequency 30MHz~1GHz

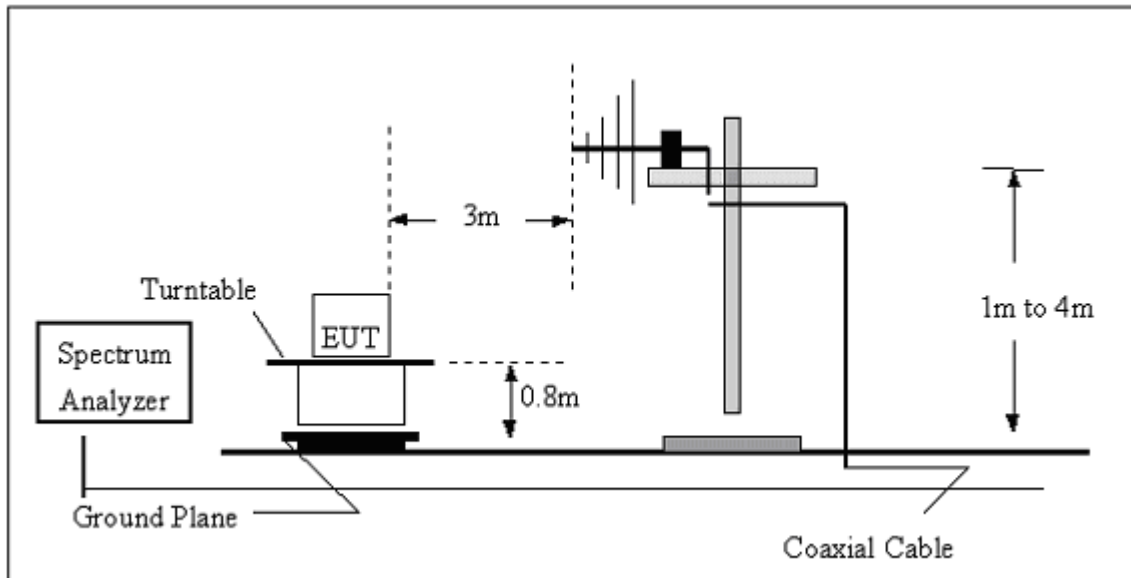

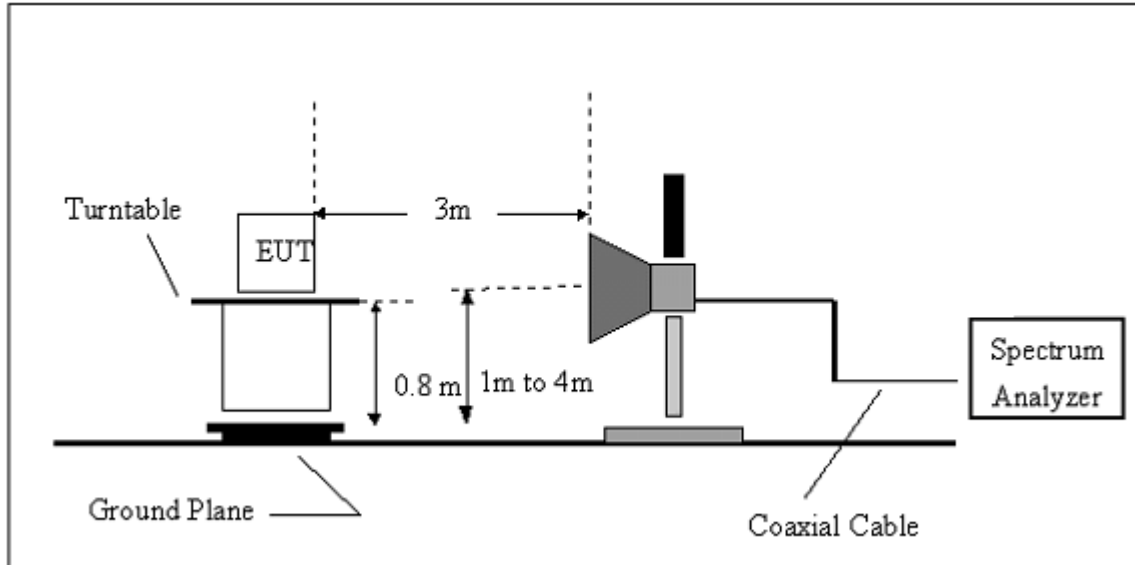
(C) Radiated Emission Test-Up Frequency Above 1GHz**3.2.5 EUT OPERATING CONDITIONS**

The EUT tested system was configured as the statements of 2.4 Unless otherwise a special operating condition is specified in the follows during the testing.

3.2.6 TEST RESULTS (BETWEEN 9KHZ – 30 MHZ)

EUT:	SMART TV BOX	Model Name. :	Q10
Temperature:	20 °C	Relative Humidity:	48%
Pressure:	1010 hPa	Test Voltage :	DC 12V from adapter AC 120V/60Hz
Test Mode :	TX	Polarization :	--

Freq.	Reading	Limit	Margin	State
(MHz)	(dBuV/m)	(dBuV/m)	(dB)	P/F
--	--	--	--	PASS
--	--	--	--	PASS

NOTE:

The amplitude of spurious emissions which are attenuated by more than 20dB below the permissible value has no need to be reported.

Distance extrapolation factor = $20 \log (\text{specific distance}/\text{test distance})(\text{dB})$;

Limit line = specific limits(dBuv) + distance extrapolation factor.

3.2.7 TEST RESULTS (BETWEEN 30MHZ – 1GHZ)

EUT :	SMART TV BOX	Model Name :	Q10
Temperature :	20 °C	Relative Humidity :	48%
Pressure :	1010 hPa	Test Voltage :	DC 12V from adapter1 AC 120V/60Hz
Test Mode :	TX	Polarization :	Horizontal

Frequency (MHz)	Meter Reading (dBμV)	Factor (dB)	Emission Level (dBμV/m)	Limits (dBμV/m)	Margin (dB)	Detector Type
41.8596	18	12.3	30.3	40	-9.7	QP
79.5207	22.8	7.65	30.45	40	-9.55	QP
134.0882	29.2	11.97	41.17	43.5	-2.33	QP
195.1365	28.45	8.68	37.13	43.5	-6.37	QP
393.4723	24.87	16.98	41.85	46	-4.15	QP
758.0407	14.89	24.36	39.25	46	-6.75	QP

Remark:
Factor = Antenna Factor + Cable Loss – Pre-amplifier.

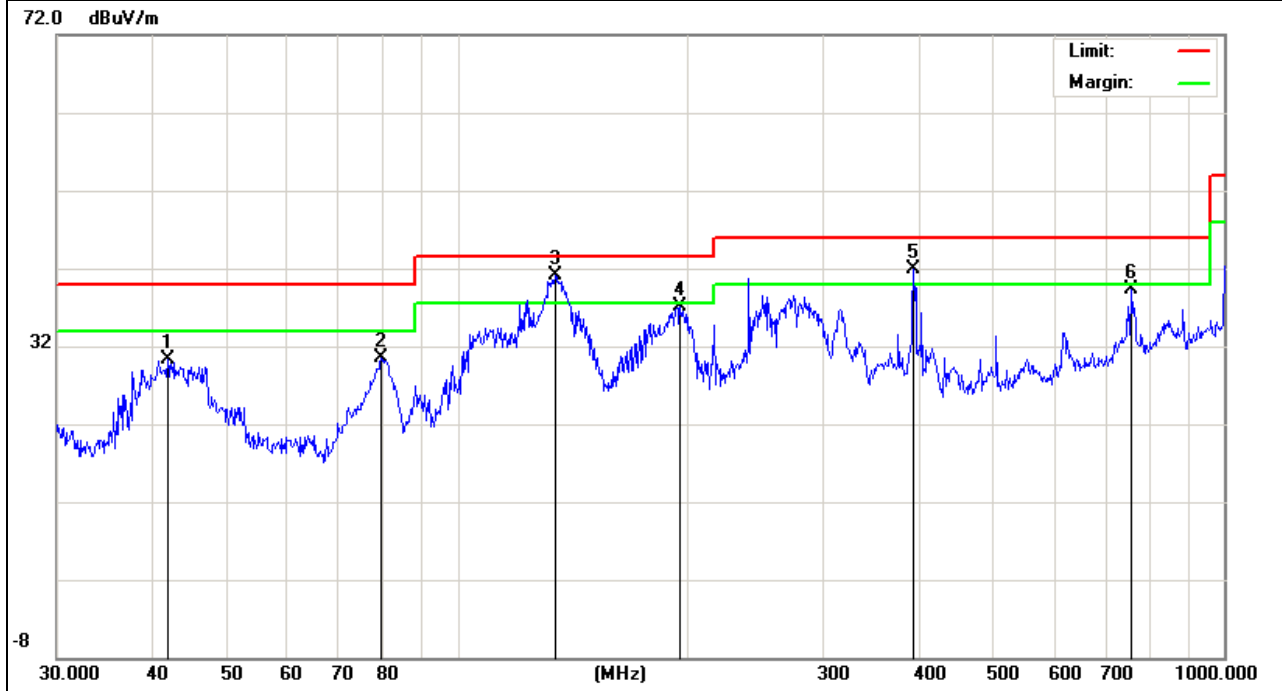

EUT :	SMART TV BOX	Model Name :	Q10
Temperature :	20 °C	Relative Humidity :	48%
Pressure :	1010 hPa	Test Voltage :	DC 12V from adapter1 AC 120V/60Hz
Test Mode :	TX	Polarization :	Vertical

Frequency (MHz)	Meter Reading (dBμV)	Factor (dB)	Emission Level (dBμV/m)	Limits (dBμV/m)	Margin (dB)	Detector Type
81.7831	27.91	8.05	35.96	40	-4.04	QP
143.8291	29.61	11.93	41.54	43.5	-1.96	QP
216.024	30.28	9.52	39.8	46	-6.2	QP
304.6099	28.31	14.59	42.9	46	-3.1	QP
344.3854	27.18	15.22	42.4	46	-3.6	QP
744.8659	16.33	24.27	40.6	46	-5.4	QP

Remark:
Factor = Antenna Factor + Cable Loss – Pre-amplifier.

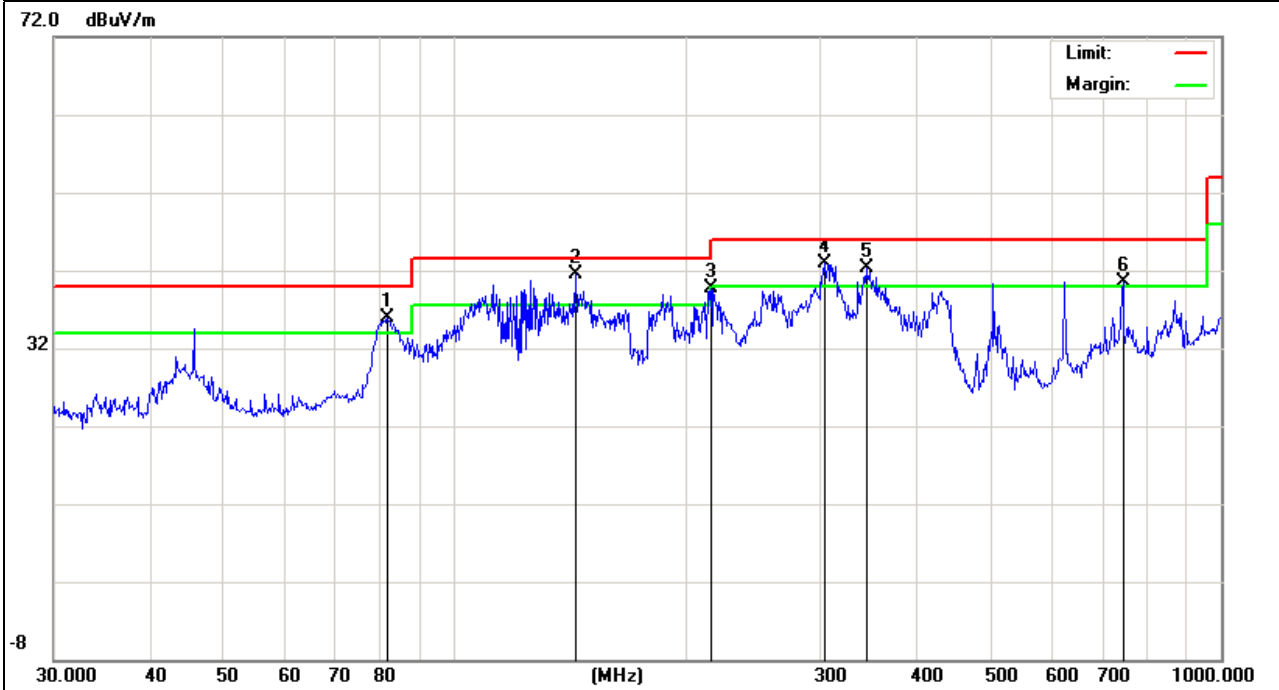

EUT :	SMART TV BOX	Model Name :	Q10
Temperature :	20 °C	Relative Humidity :	48%
Pressure :	1010 hPa	Test Voltage :	DC 12V from adapter2 AC 120V/60Hz
Test Mode :	TX	Polarization :	Horizontal

Frequency (MHz)	Meter Reading (dBμV)	Factor (dB)	Emission Level (dBμV/m)	Limits (dBμV/m)	Margin (dB)	Detector Type
185.1379	28.04	9.67	37.71	43.5	-5.79	QP
216.024	26.47	9.98	36.45	46	-9.55	QP
311.0867	22.59	15.09	37.68	46	-8.32	QP
504.7062	22.65	20.74	43.39	46	-2.61	QP
875.247	16.74	27.32	44.06	46	-1.94	QP

Remark:
 Factor = Antenna Factor + Cable Loss – Pre-amplifier.

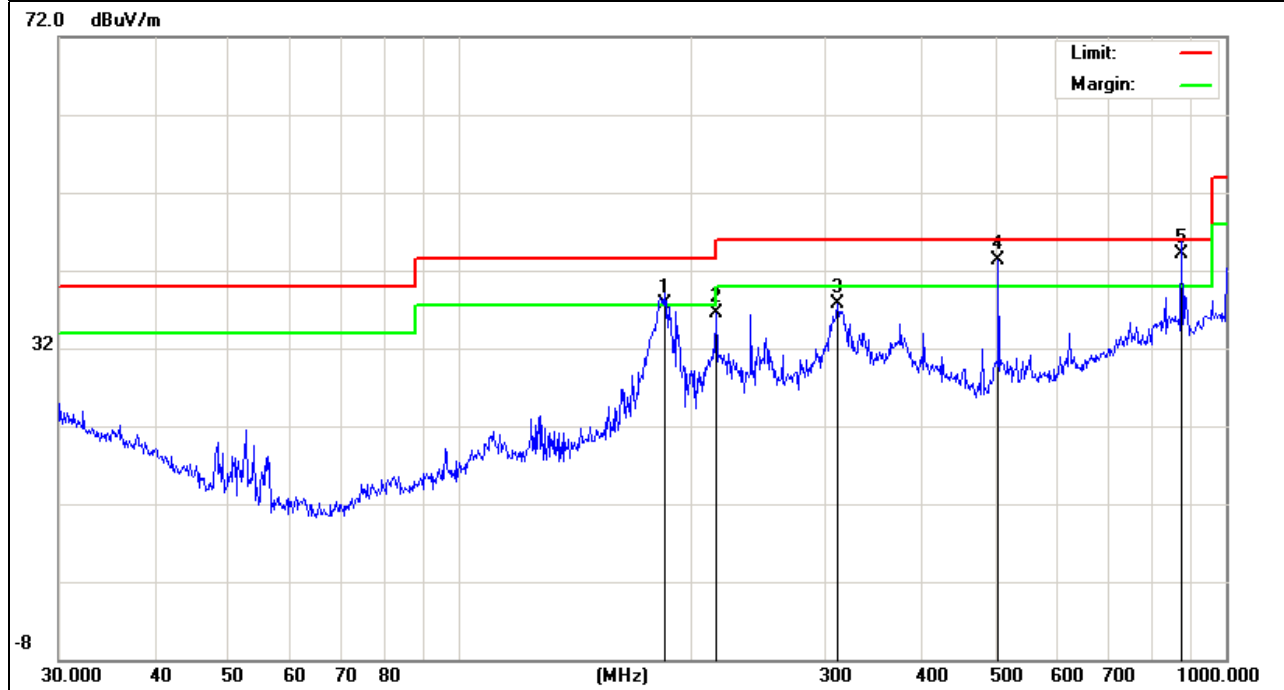

EUT :	SMART TV BOX	Model Name :	Q10
Temperature :	20 °C	Relative Humidity :	48%
Pressure :	1010 hPa	Test Voltage :	DC 12V from adapter2 AC 120V/60Hz
Test Mode :	TX	Polarization :	Vertical

Frequency (MHz)	Meter Reading (dBμV)	Factor (dB)	Emission Level (dBμV/m)	Limits (dBμV/m)	Margin (dB)	Detector Type
40.4172	18.74	13.15	31.89	40	-8.11	QP
112.1304	17.91	11.77	29.68	43.5	-13.82	QP
185.1379	24.81	9.67	34.48	43.5	-9.02	QP
504.7062	24.16	20.74	44.9	46	-1.1	QP
679.96	20.11	23.94	44.05	46	-1.95	QP

Remark:
Factor = Antenna Factor + Cable Loss – Pre-amplifier.

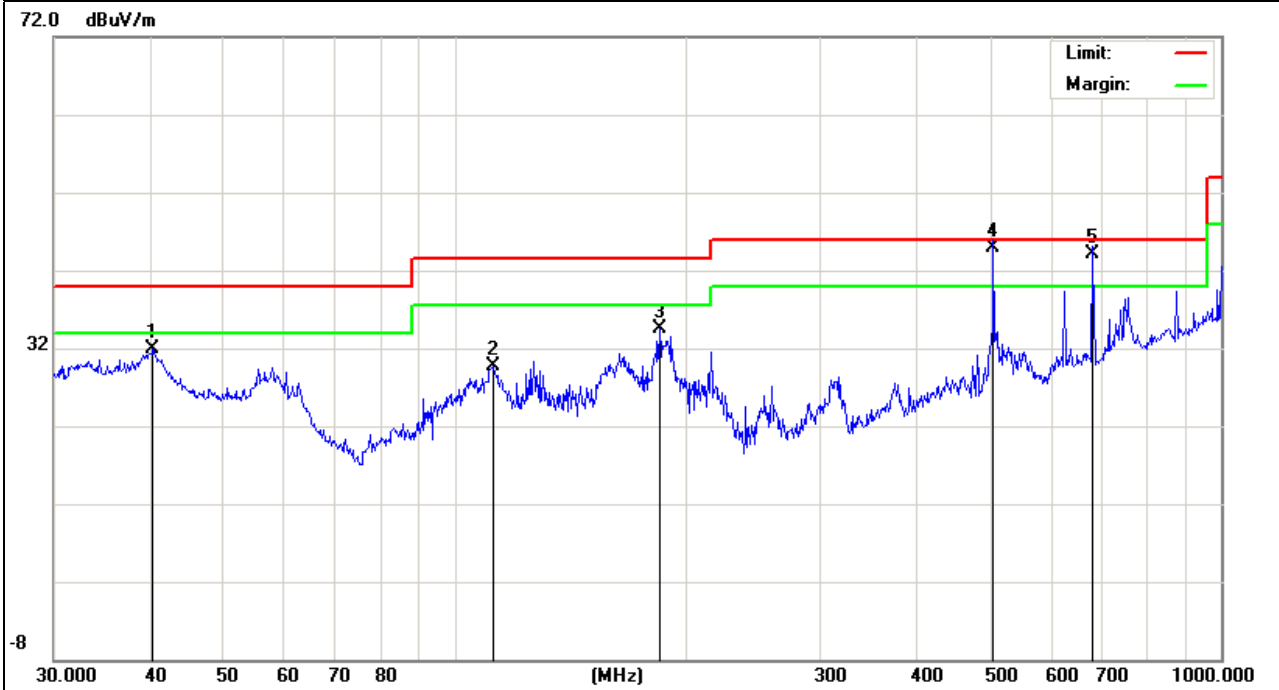

3.2.8 TEST RESULTS (ABOVE 1000 MHZ)

EUT :	SMART TV BOX	Model Name :	Q10
Temperature :	20 °C	Relative Humidity :	48%
Pressure :	1010 hPa	Test Voltage :	DC 12V from adapter AC 120V/60Hz
Test Mode :	CH1 (802.11b Mode)/2412	Polarization :	Horizontal

Frequency (MHz)	Meter Reading (dBμV)	Factor (dB)	Emission Level (dBμV/m)	Limits (dBμV/m)	Margin (dB)	Detector Type
4824.348	52.11	10.44	62.55	74	-11.45	peak
4824.348	33.18	10.44	43.62	54	-10.38	AVG
7236.473	44.35	12.39	56.74	74	-17.26	peak
7236.473	29	12.39	41.39	54	-12.61	AVG

Remark:
Factor = Antenna Factor + Cable Loss – Pre-amplifier.

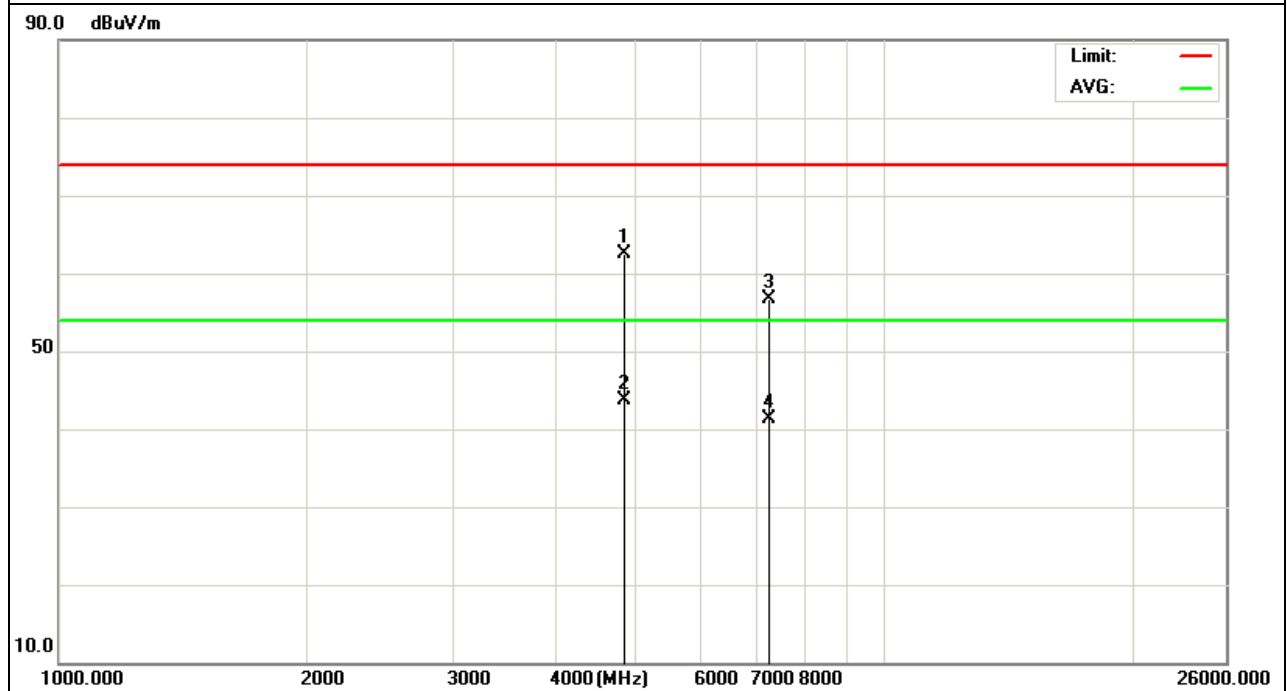

EUT :	SMART TV BOX	Model Name :	Q10
Temperature :	20 °C	Relative Humidity :	48%
Pressure :	1010 hPa	Test Voltage :	DC 12V from adapter AC 120V/60Hz
Test Mode :	CH1 (802.11b Mode)/2412	Polarization :	Vertical

Frequency (MHz)	Meter Reading (dBμV)	Factor (dB)	Emission Level (dBμV/m)	Limits (dBμV/m)	Margin (dB)	Detector Type
4874.247	51.17	10.4	61.57	74	-12.43	peak
4874.247	31.98	10.4	42.38	54	-11.62	AVG
7311.231	41.61	12.75	54.36	74	-19.64	peak
7311.231	27.66	12.75	40.41	54	-13.59	AVG

Remark:
Factor = Antenna Factor + Cable Loss – Pre-amplifier.

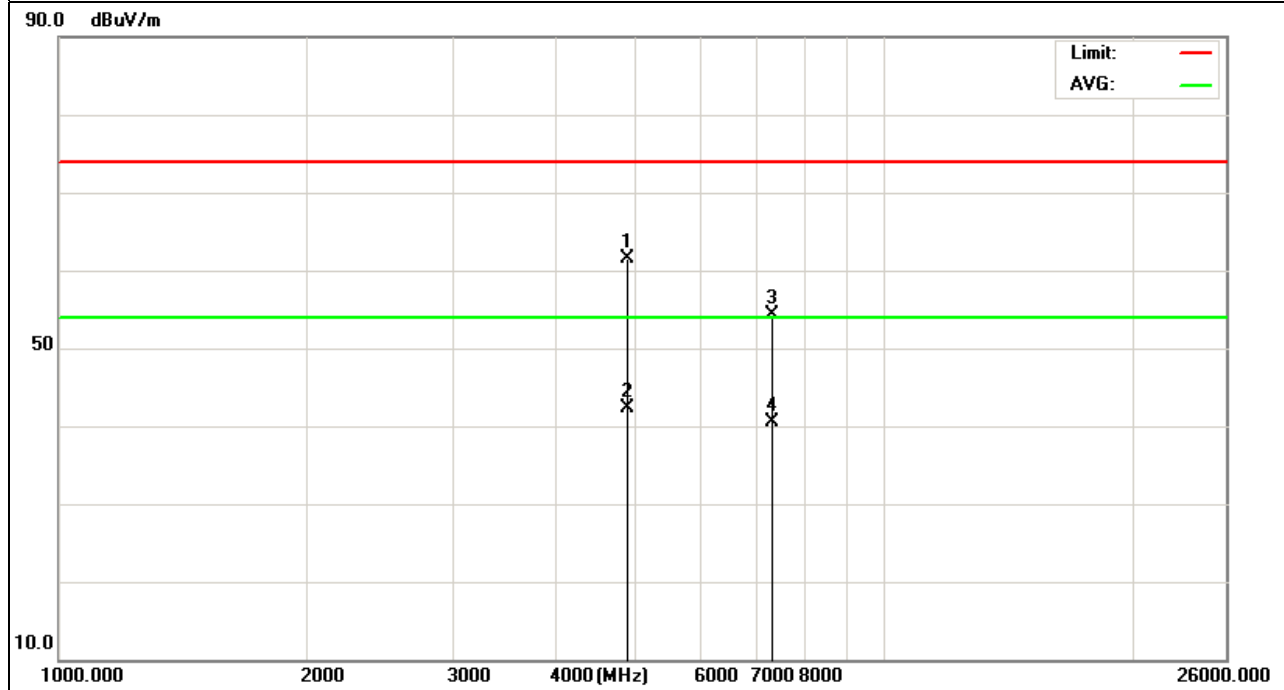

EUT :	SMART TV BOX	Model Name :	Q10
Temperature :	20 °C	Relative Humidity :	48%
Pressure :	1010 hPa	Test Voltage :	DC 12V from adapter AC 120V/60Hz
Test Mode :	CH6 (802.11b Mode)/2437	Polarization :	Horizontal

Frequency (MHz)	Meter Reading (dBμV)	Factor (dB)	Emission Level (dBμV/m)	Limits (dBμV/m)	Margin (dB)	Detector Type
4874.234	49.82	10.4	60.22	74	-13.78	peak
4874.234	32.76	10.4	43.16	54	-10.84	AVG
7311.748	42.62	12.75	55.37	74	-18.63	peak
7311.748	29.68	12.75	42.43	54	-11.57	AVG

Remark:
Factor = Antenna Factor + Cable Loss – Pre-amplifier.

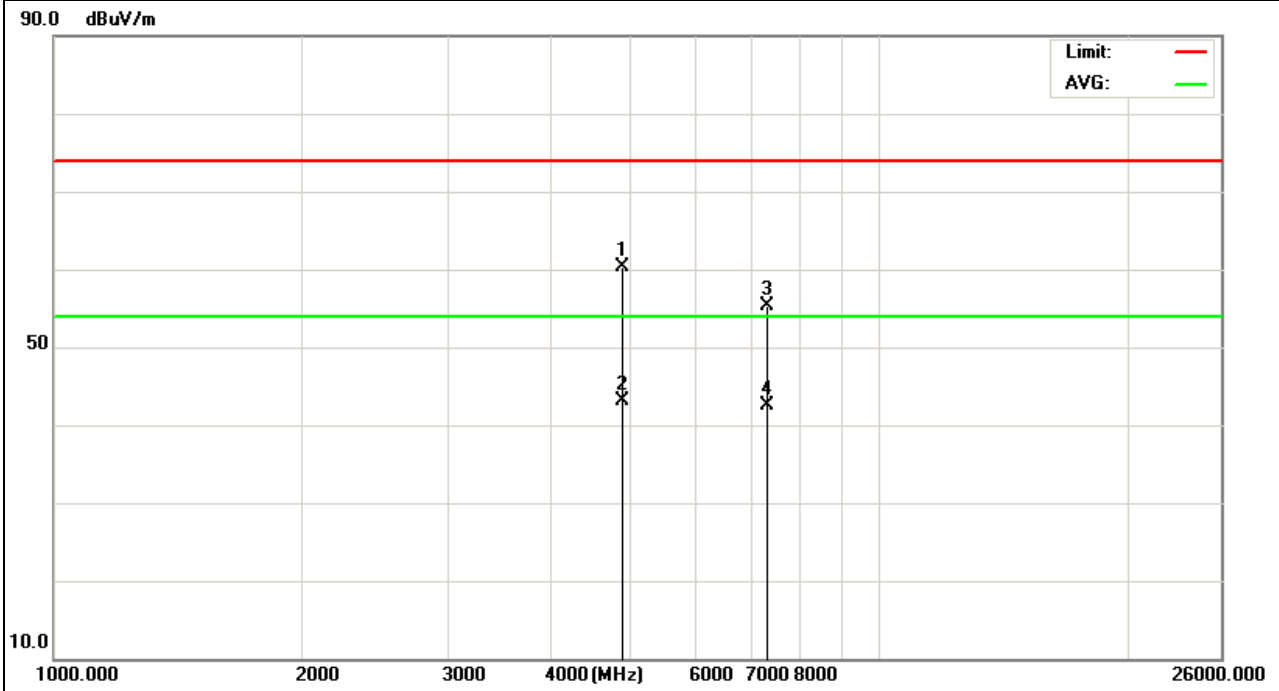

EUT :	SMART TV BOX	Model Name :	Q10
Temperature :	20 °C	Relative Humidity :	48%
Pressure :	1010 hPa	Test Voltage :	DC 12V from adapter AC 120V/60Hz
Test Mode :	CH6 (802.11b Mode)/2437	Polarization :	Vertical

Frequency (MHz)	Meter Reading (dBμV)	Factor (dB)	Emission Level (dBμV/m)	Limits (dBμV/m)	Margin (dB)	Detector Type
4924.341	52.96	10.39	63.35	74	-10.65	peak
4934.341	32.05	10.44	42.49	54	-11.51	AVG
7386.208	42.55	12.68	55.23	74	-18.77	peak
7386.208	28.99	12.68	41.67	54	-12.33	AVG

Remark:

- Factor = Antenna Factor + Cable Loss – Pre-amplifier.
- No emission detected above 18GHz

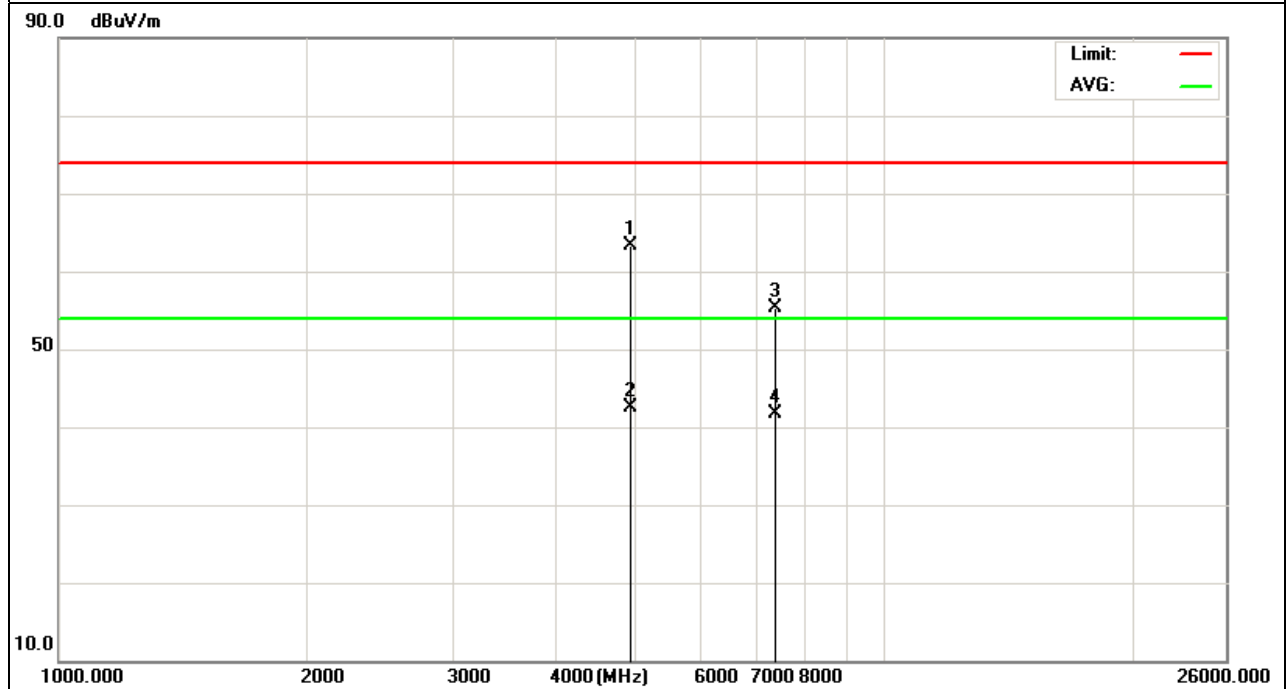

EUT :	SMART TV BOX	Model Name :	Q10
Temperature :	20 °C	Relative Humidity :	48%
Pressure :	1010 hPa	Test Voltage :	DC 12V from adapter AC 120V/60Hz
Test Mode :	CH11 (802.11b Mode)/2462	Polarization :	Horizontal

Frequency (MHz)	Meter Reading (dBμV)	Factor (dB)	Emission Level (dBμV/m)	Limits (dBμV/m)	Margin (dB)	Detector Type
4924.155	51.46	10.39	61.85	74	-12.15	peak
4924.155	33.27	10.39	43.66	54	-10.34	AVG
7386.242	42.89	12.68	55.57	74	-18.43	peak
7386.242	28.61	12.68	41.29	54	-12.71	AVG

Remark:

- Factor = Antenna Factor + Cable Loss – Pre-amplifier.
- No emission detected above 18GHz

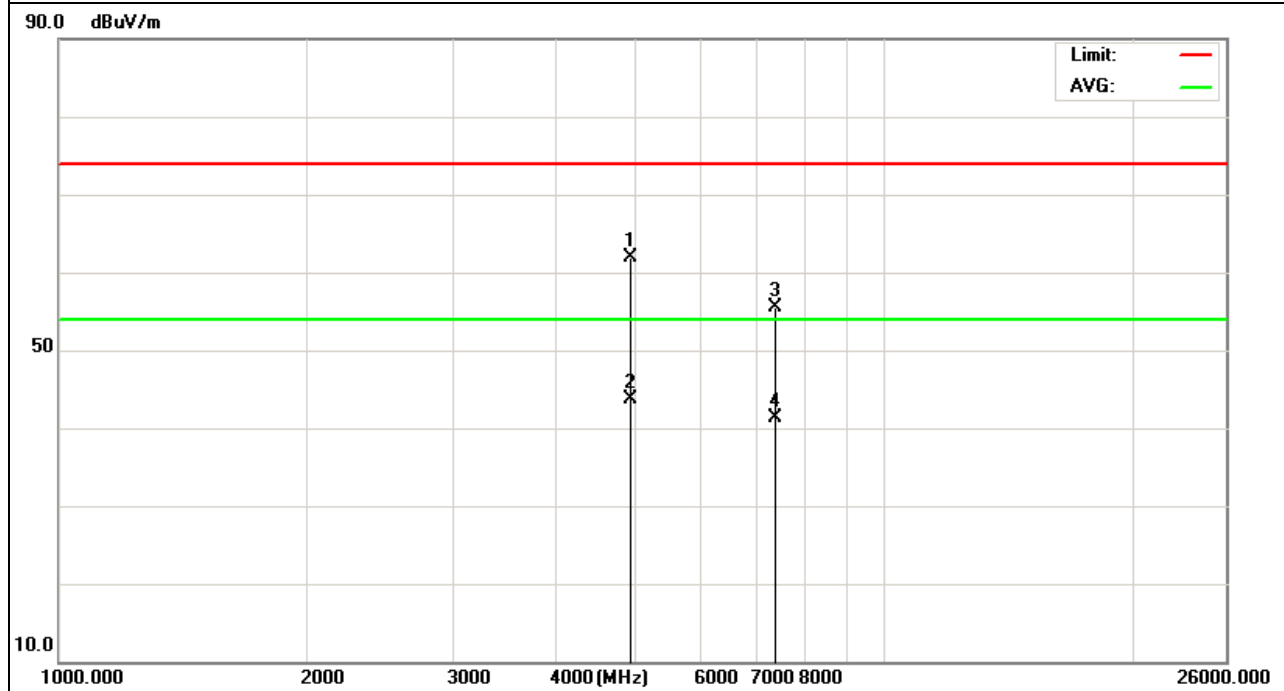

EUT :	SMART TV BOX	Model Name :	Q10
Temperature :	20 °C	Relative Humidity :	48%
Pressure :	1010 hPa	Test Voltage :	DC 12V from adapter AC 120V/60Hz
Test Mode :	CH11 (802.11b Mode)/2462	Polarization :	Vertical

Frequency (MHz)	Meter Reading (dBμV)	Factor (dB)	Emission Level (dBμV/m)	Limits (dBμV/m)	Margin (dB)	Detector Type
4924.238	51.84	10.39	62.23	74	-11.77	peak
4924.238	32.09	10.39	42.48	54	-11.52	AVG
7386.346	42.94	12.68	55.62	74	-18.38	peak
7386.346	27.91	12.68	40.59	54	-13.41	AVG

Remark:
Factor = Antenna Factor + Cable Loss – Pre-amplifier.

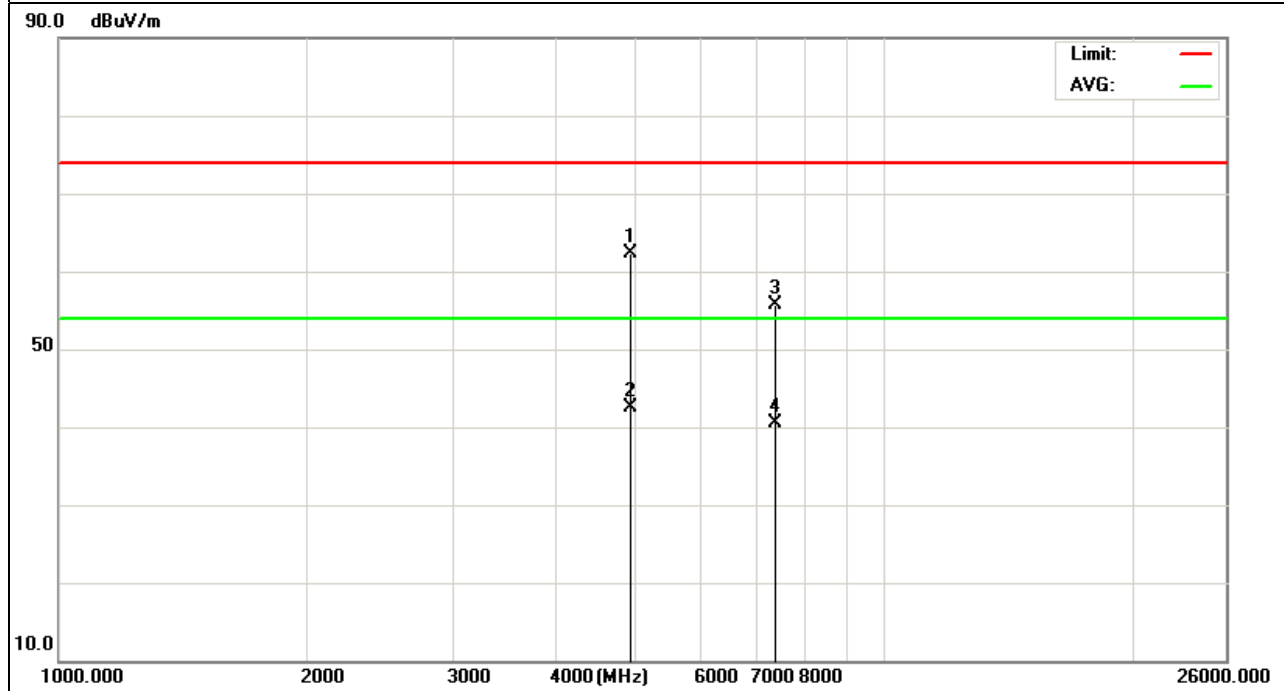

EUT :	SMART TV BOX	Model Name :	Q10
Temperature :	20 °C	Relative Humidity :	48%
Pressure :	1010 hPa	Test Voltage :	DC 12V from adapter AC 120V/60Hz
Test Mode :	CH1 (802.11g Mode)/2412	Polarization :	Horizontal

Frequency (MHz)	Meter Reading (dBμV)	Factor (dB)	Emission Level (dBμV/m)	Limits (dBμV/m)	Margin (dB)	Detector Type
4824.374	47.03	10.44	57.47	74	-16.53	peak
4824.374	30.88	10.44	41.32	54	-12.68	AVG
7236.522	40.99	12.39	53.38	74	-20.62	peak
7236.522	26.07	12.39	38.46	54	-15.54	AVG

Remark:
Factor = Antenna Factor + Cable Loss – Pre-amplifier.

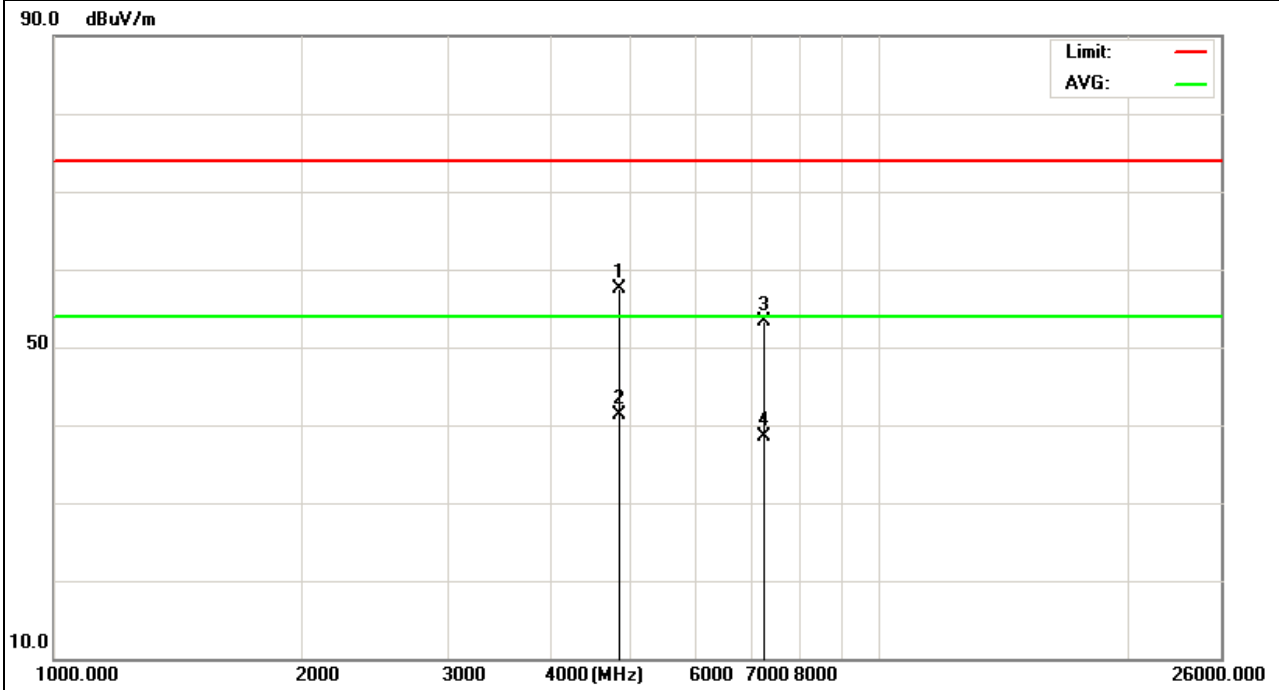

EUT :	SMART TV BOX	Model Name :	Q10
Temperature :	20 °C	Relative Humidity :	48%
Pressure :	1010 hPa	Test Voltage :	DC 12V from adapter AC 120V/60Hz
Test Mode :	CH1 (802.11g Mode)/2412	Polarization :	Vertical

Frequency (MHz)	Meter Reading (dBμV)	Factor (dB)	Emission Level (dBμV/m)	Limits (dBμV/m)	Margin (dB)	Detector Type
4824.168	48.08	10.44	58.52	74	-15.48	peak
4824.168	32.04	10.44	42.48	54	-11.52	AVG
7236.342	41.99	12.39	54.38	74	-19.62	peak
7236.342	28.27	12.39	40.66	54	-13.34	AVG

Remark:
Factor = Antenna Factor + Cable Loss – Pre-amplifier.

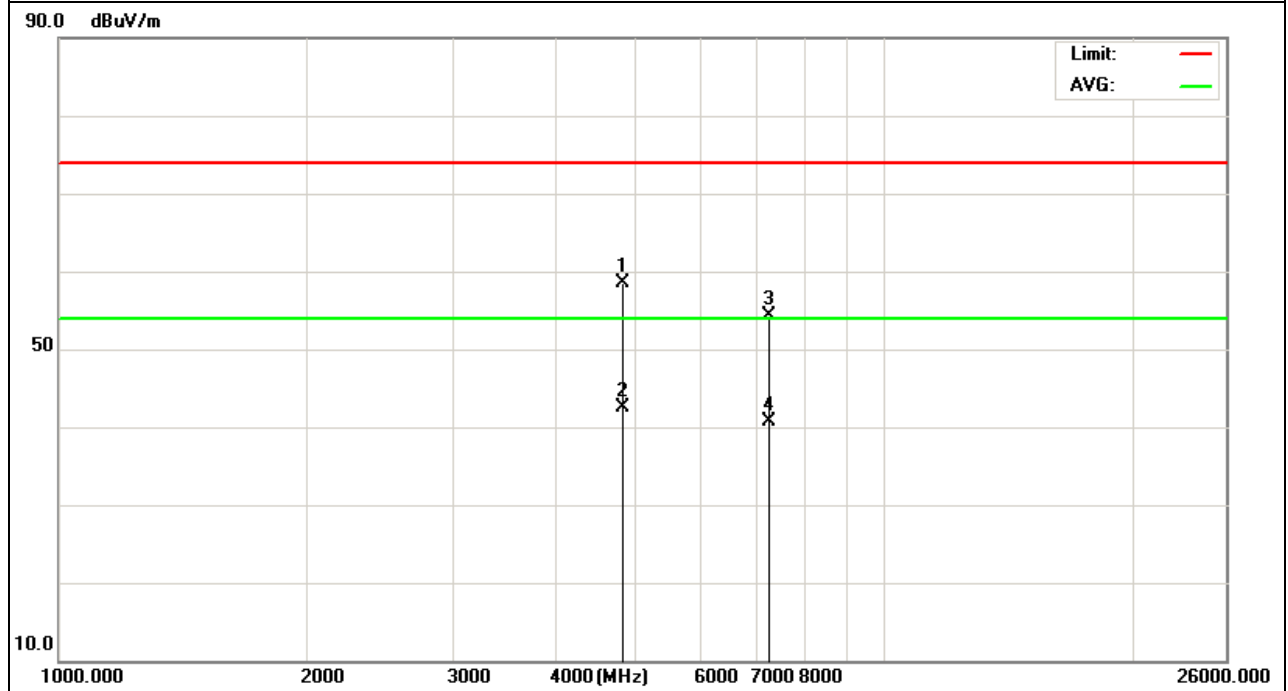

EUT :	SMART TV BOX	Model Name :	Q10
Temperature :	20 °C	Relative Humidity :	48%
Pressure :	1010 hPa	Test Voltage :	DC 12V from adapter AC 120V/60Hz
Test Mode :	CH6 (802.11g Mode)/2437	Polarization :	Horizontal

Frequency (MHz)	Meter Reading (dBμV)	Factor (dB)	Emission Level (dBμV/m)	Limits (dBμV/m)	Margin (dB)	Detector Type
4874.145	48.02	10.4	58.42	74	-15.58	peak
4874.145	31.42	10.4	41.82	54	-12.18	AVG
7311.269	41.68	12.75	54.43	74	-19.57	peak
7311.269	26.97	12.75	39.72	54	-14.28	AVG

Remark:
Factor = Antenna Factor + Cable Loss – Pre-amplifier.

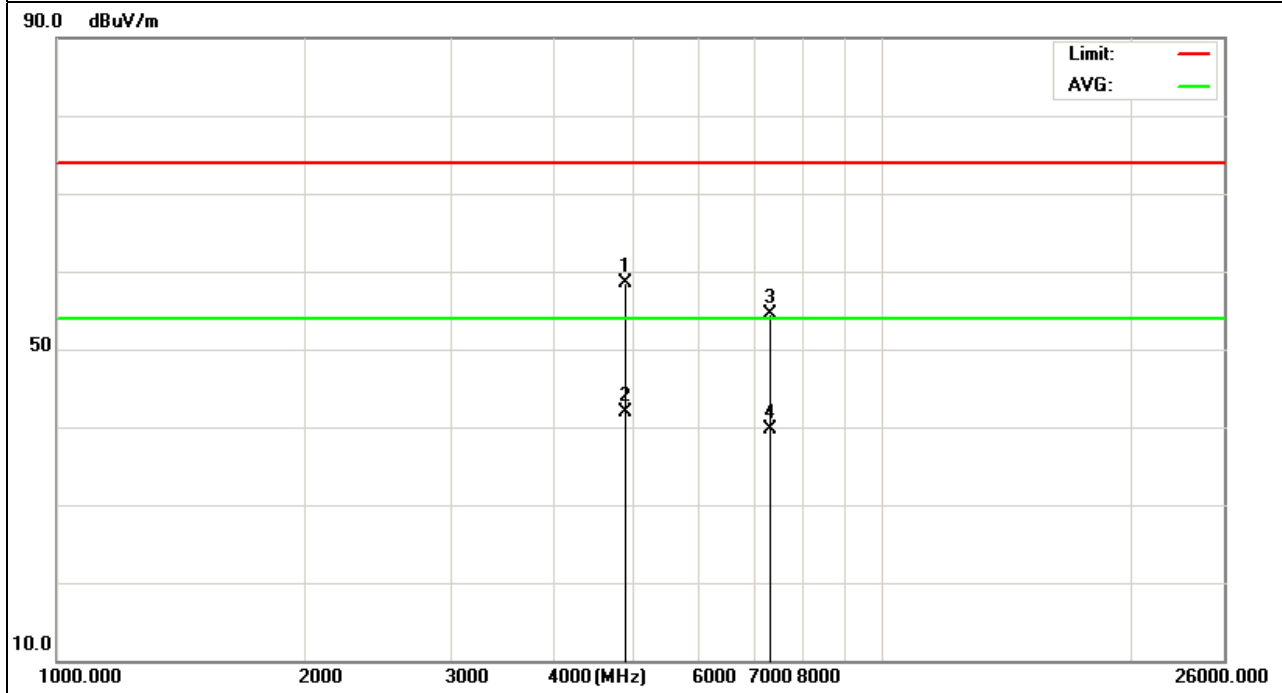

EUT :	SMART TV BOX	Model Name :	Q10
Temperature :	20 °C	Relative Humidity :	48%
Pressure :	1010 hPa	Test Voltage :	DC 12V from adapter AC 120V/60Hz
Test Mode :	CH6 (802.11g Mode)/2437	Polarization :	Vertical

Frequency (MHz)	Meter Reading (dBμV)	Factor (dB)	Emission Level (dBμV/m)	Limits (dBμV/m)	Margin (dB)	Detector Type
4874.177	48.07	10.4	58.47	74	-15.53	peak
4874.177	31.89	10.4	42.29	54	-11.71	AVG
7311.224	42.78	12.75	55.53	74	-18.47	peak
7311.224	27.99	12.75	40.74	54	-13.26	AVG

Remark:
Factor = Antenna Factor + Cable Loss – Pre-amplifier.

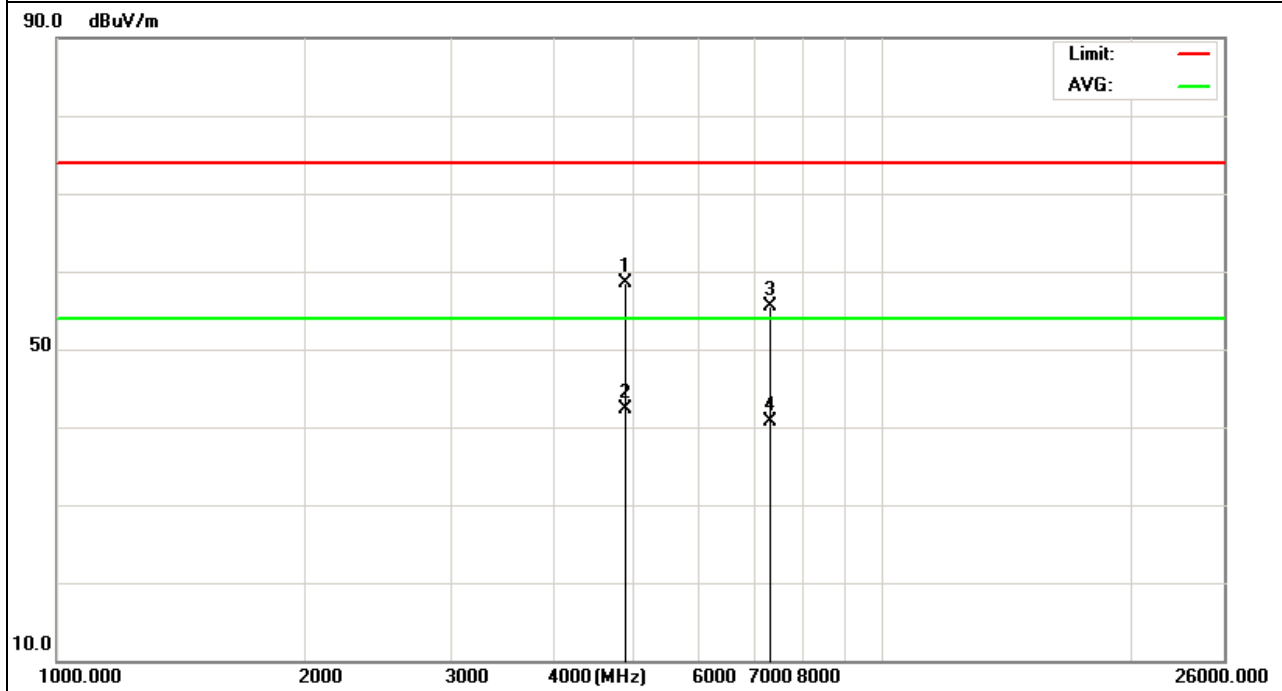

EUT :	SMART TV BOX	Model Name :	Q10
Temperature :	20 °C	Relative Humidity :	48%
Pressure :	1010 hPa	Test Voltage :	DC 12V from adapter AC 120V/60Hz
Test Mode :	CH11 (802.11g Mode)/2462	Polarization :	Horizontal

Frequency (MHz)	Meter Reading (dBµV)	Factor (dB)	Emission Level (dBµV/m)	Limits (dBµV/m)	Margin (dB)	Detector Type
4924.235	48.12	10.39	58.51	74	-15.49	peak
4924.235	33.07	10.39	43.46	54	-10.54	AVG
7386.316	42.81	12.68	55.49	74	-18.51	peak
7386.316	27.89	12.68	40.57	54	-13.43	AVG

Remark:
Factor = Antenna Factor + Cable Loss – Pre-amplifier.

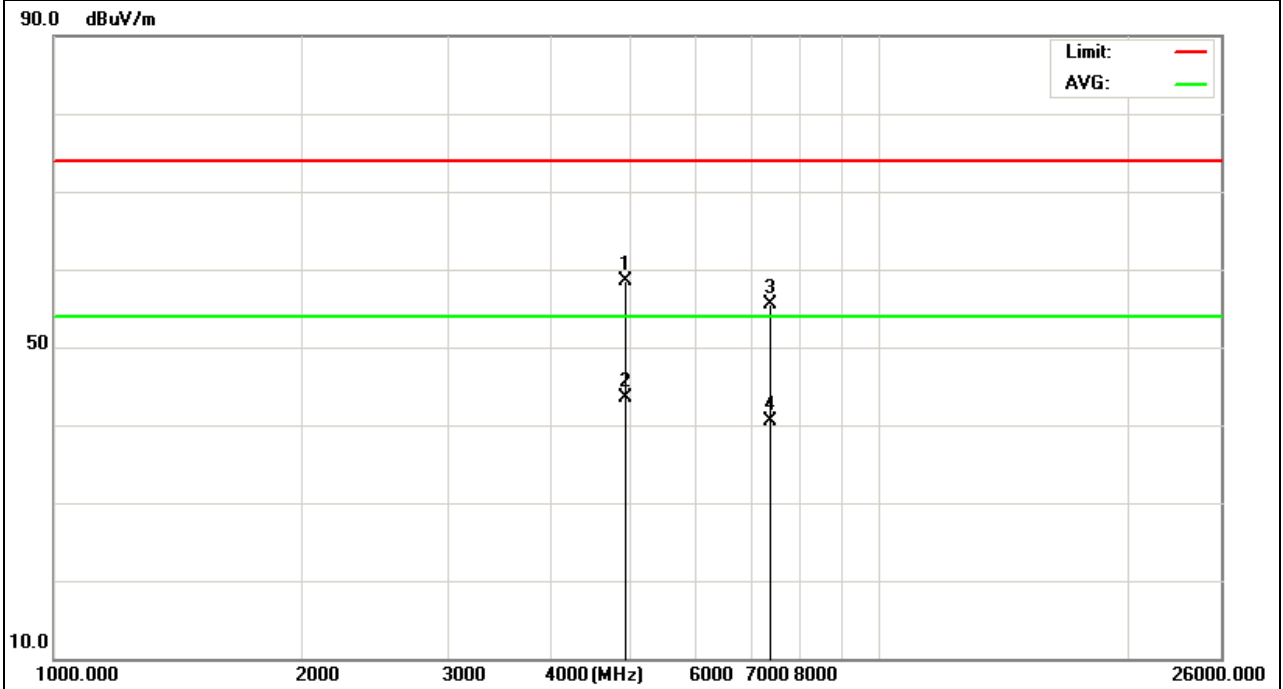

EUT :	SMART TV BOX	Model Name :	Q10
Temperature :	20 °C	Relative Humidity :	48%
Pressure :	1010 hPa	Test Voltage :	DC 12V from adapter AC 120V/60Hz
Test Mode :	CH11(802.11g Mode)/2462	Polarization :	Vertical

Frequency (MHz)	Meter Reading (dBμV)	Factor (dB)	Emission Level (dBμV/m)	Limits (dBμV/m)	Margin (dB)	Detector Type
4924.146	47.43	10.39	57.82	74	-16.18	peak
4924.146	32.54	10.39	42.93	54	-11.07	AVG
7386.225	42.19	12.68	54.87	74	-19.13	peak
7386.225	28.75	12.68	41.43	54	-12.57	AVG

Remark:
Factor = Antenna Factor + Cable Loss – Pre-amplifier.

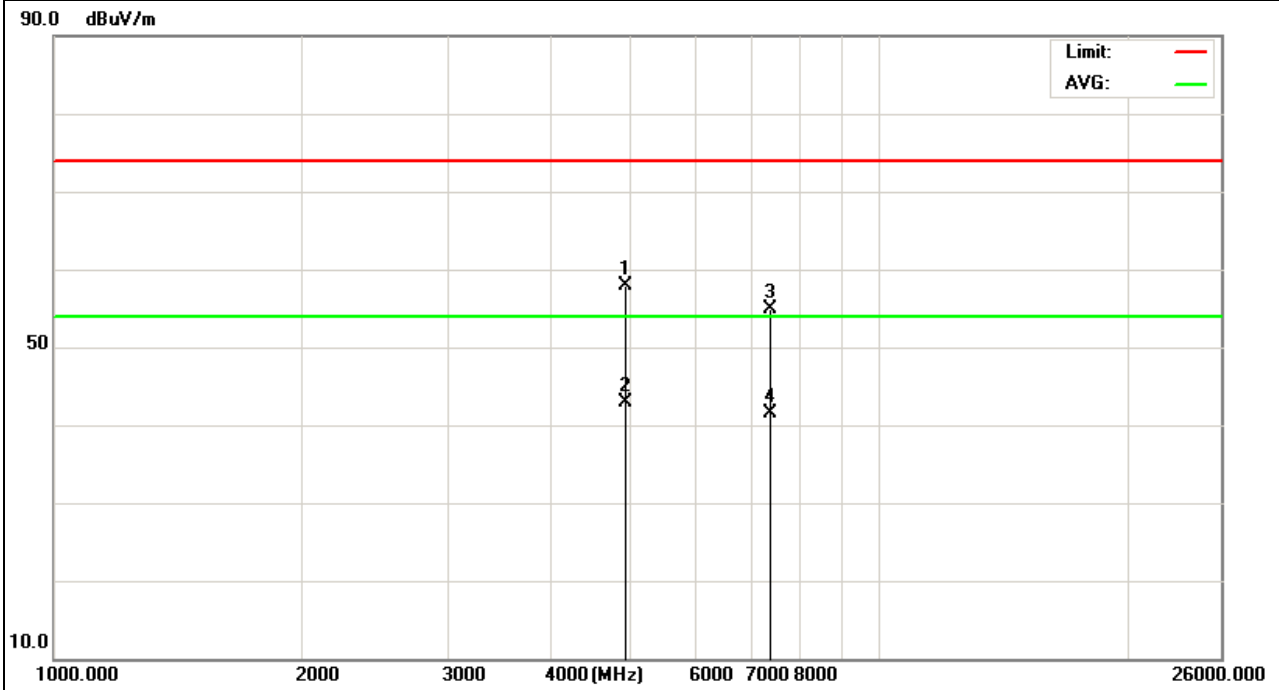

EUT :	SMART TV BOX	Model Name :	Q10
Temperature :	20 °C	Relative Humidity :	48%
Pressure :	1010 hPa	Test Voltage :	DC 12V from adapter AC 120V/60Hz
Test Mode :	CH1(802.11n Mode)	Polarization :	Horizontal

Frequency (MHz)	Meter Reading (dBμV)	Factor (dB)	Emission Level (dBμV/m)	Limits (dBμV/m)	Margin (dB)	Detector Type
4824.062	49.08	10.44	59.52	74	-14.48	peak
4824.062	33.04	10.44	43.48	54	-10.52	AVG
7236.351	41.47	12.39	53.86	74	-20.14	peak
7236.351	29.4	12.39	41.79	54	-12.21	AVG

Remark:
Factor = Antenna Factor + Cable Loss – Pre-amplifier.

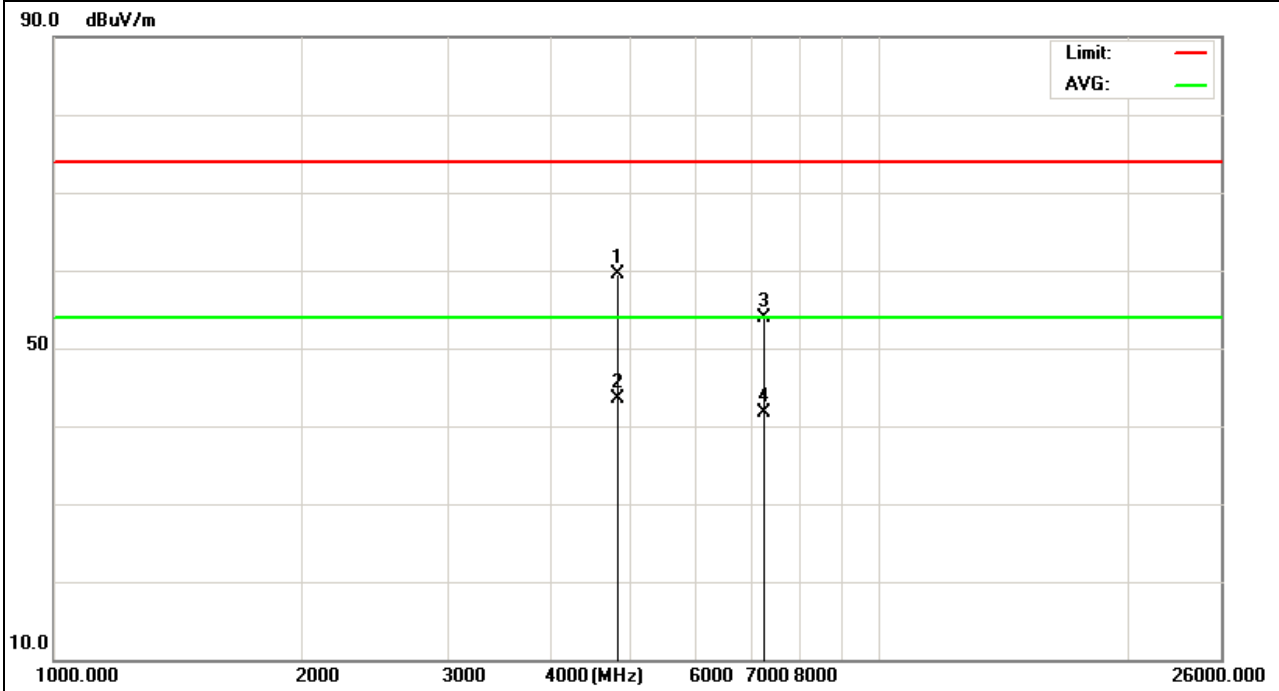

EUT :	SMART TV BOX	Model Name :	Q10
Temperature :	20 °C	Relative Humidity :	48%
Pressure :	1010 hPa	Test Voltage :	DC 12V from adapter AC 120V/60Hz
Test Mode :	CH1(802.11n Mode)	Polarization :	Vertical

Frequency (MHz)	Meter Reading (dBµV)	Factor (dB)	Emission Level (dBµV/m)	Limits (dBµV/m)	Margin (dB)	Detector Type
4824.247	48.15	10.44	58.59	74	-15.41	peak
4824.247	32.3	10.44	42.74	54	-11.26	AVG
7236.336	41.87	12.39	54.26	74	-19.74	peak
7236.336	28.23	12.39	40.62	54	-13.38	AVG

Remark:
Factor = Antenna Factor + Cable Loss – Pre-amplifier.

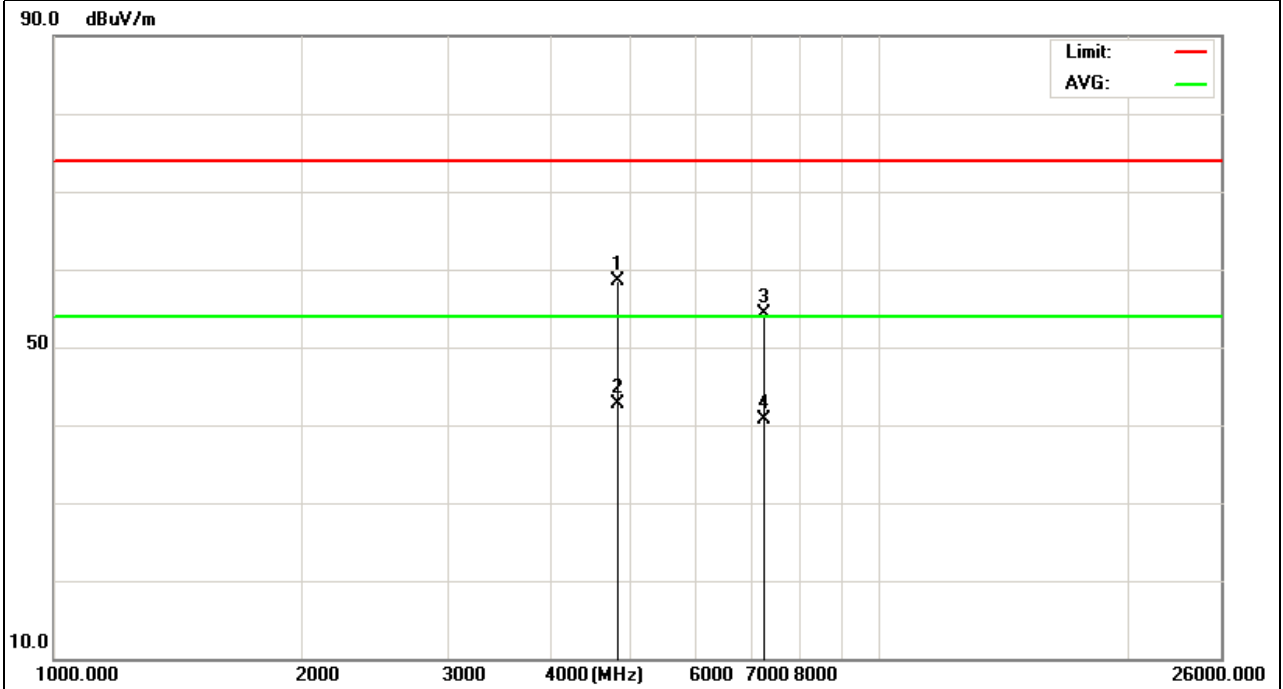

EUT :	SMART TV BOX	Model Name :	Q10
Temperature :	20 °C	Relative Humidity :	48%
Pressure :	1010 hPa	Test Voltage :	DC 12V from adapter AC 120V/60Hz
Test Mode :	CH6(802.11n Mode)	Polarization :	Horizontal

Frequency (MHz)	Meter Reading (dBμV)	Factor (dB)	Emission Level (dBμV/m)	Limits (dBμV/m)	Margin (dB)	Detector Type
4874.437	48.41	10.4	58.81	74	-15.19	peak
4874.437	31.04	10.4	41.44	54	-12.56	AVG
7311.265	41.6	12.75	54.35	74	-19.65	peak
7311.265	26.84	12.75	39.59	54	-14.41	AVG

Remark:
Factor = Antenna Factor + Cable Loss – Pre-amplifier.

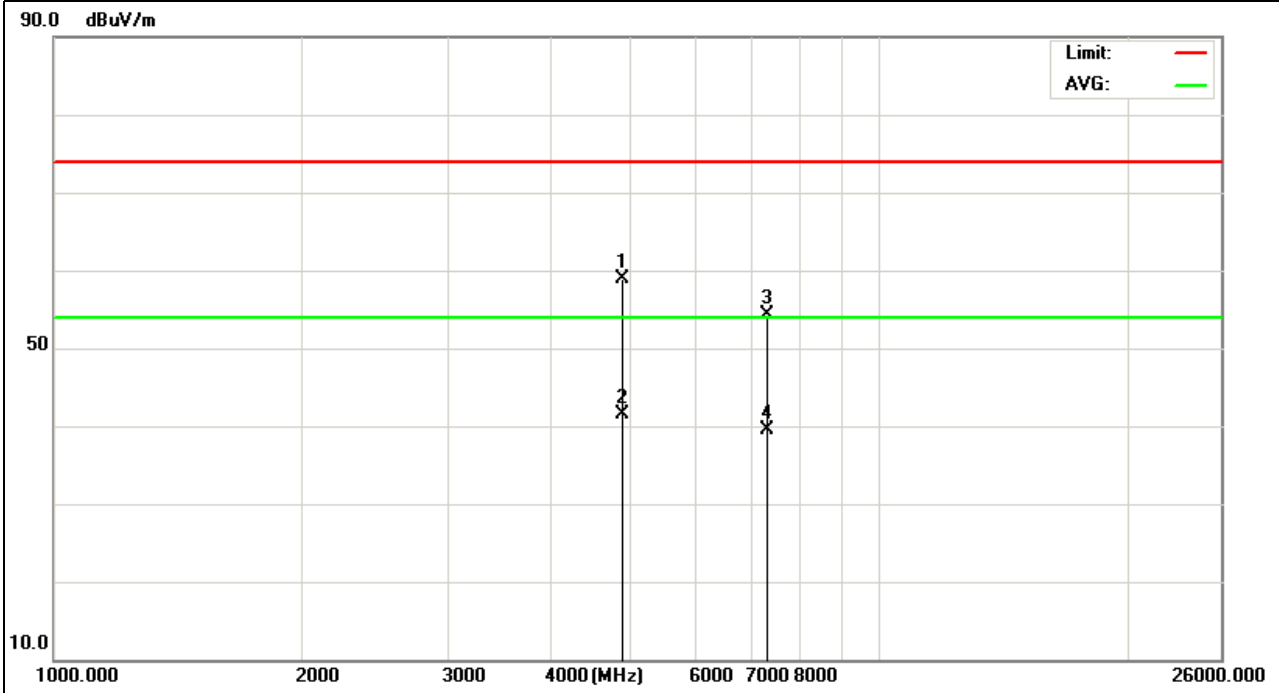

EUT :	SMART TV BOX	Model Name :	Q10
Temperature :	20 °C	Relative Humidity :	48%
Pressure :	1010 hPa	Test Voltage :	DC 12V from adapter AC 120V/60Hz
Test Mode :	CH6(802.11n Mode)	Polarization :	Vertical

Frequency (MHz)	Meter Reading (dBµV)	Factor (dB)	Emission Level (dBµV/m)	Limits (dBµV/m)	Margin (dB)	Detector Type
4874.428	47.85	10.4	58.25	74	-15.75	peak
4874.428	31.23	10.4	41.63	54	-12.37	AVG
7311.374	41.73	12.75	54.48	74	-19.52	peak
7311.374	27.54	12.75	40.29	54	-13.71	AVG

Remark:
Factor = Antenna Factor + Cable Loss – Pre-amplifier.

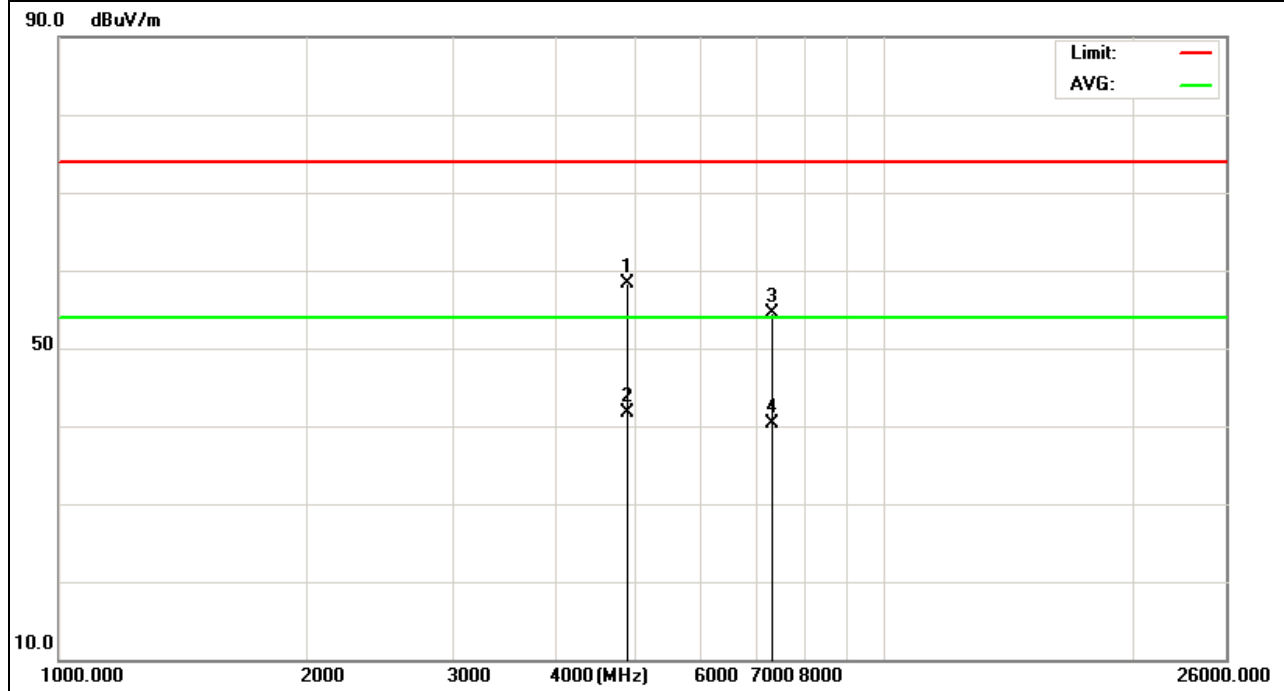

EUT :	SMART TV BOX	Model Name :	Q10
Temperature :	20 °C	Relative Humidity :	48%
Pressure :	1010 hPa	Test Voltage :	DC 12V from adapter AC 120V/60Hz
Test Mode :	CH11(802.11n Mode)	Polarization :	Horizontal

Frequency (MHz)	Meter Reading (dBμV)	Factor (dB)	Emission Level (dBμV/m)	Limits (dBμV/m)	Margin (dB)	Detector Type
4924.248	48.96	10.39	59.35	74	-14.65	peak
4924.248	31.08	10.39	41.47	54	-12.53	AVG
7386.386	41.97	12.69	54.66	74	-19.34	peak
7386.386	26.99	12.69	39.68	54	-14.32	AVG

Remark:
Factor = Antenna Factor + Cable Loss – Pre-amplifier.

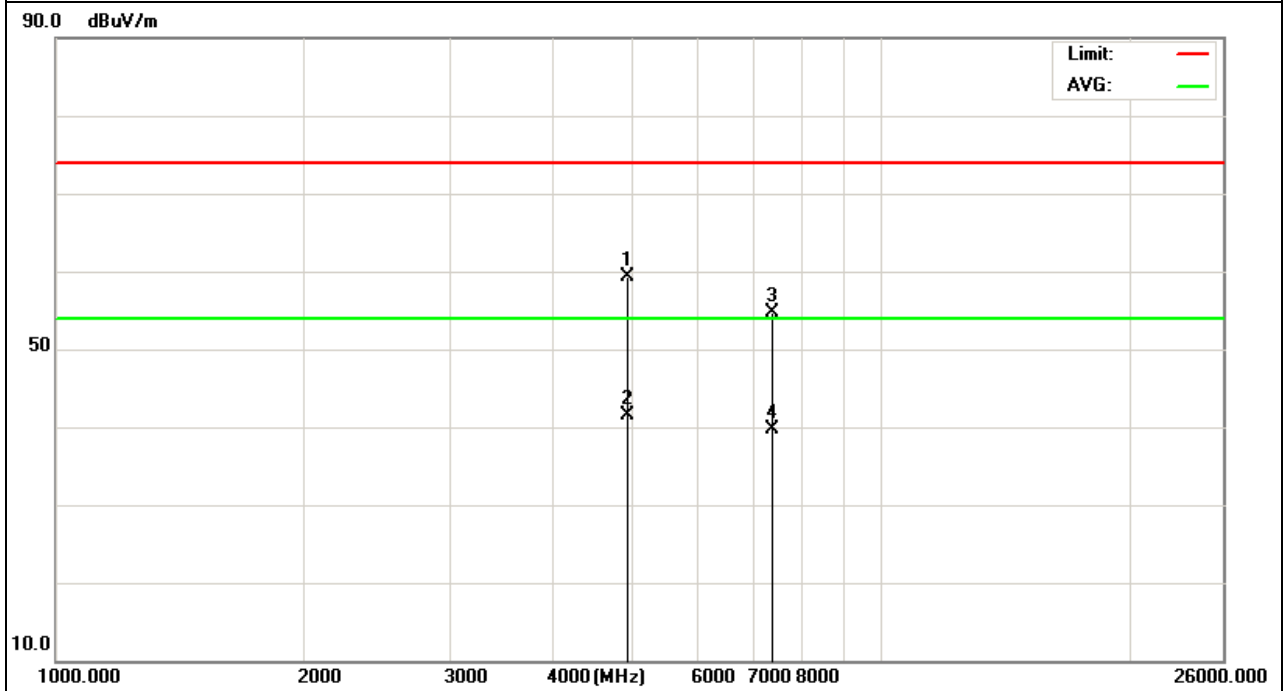

EUT :	SMART TV BOX	Model Name :	Q10
Temperature :	20 °C	Relative Humidity :	48%
Pressure :	1010 hPa	Test Voltage :	DC 12V from adapter AC 120V/60Hz
Test Mode :	CH11(802.11n Mode)	Polarization :	Vertical

Frequency (MHz)	Meter Reading (dBμV)	Factor (dB)	Emission Level (dBμV/m)	Limits (dBμV/m)	Margin (dB)	Detector Type
4924.319	49.03	10.39	59.42	74	-14.58	peak
4924.319	31.99	10.39	42.38	54	-11.62	AVG
7386.157	43.88	12.68	56.56	74	-17.44	peak
7386.157	28.05	12.68	40.73	54	-13.27	AVG

Remark:
Factor = Antenna Factor + Cable Loss – Pre-amplifier.

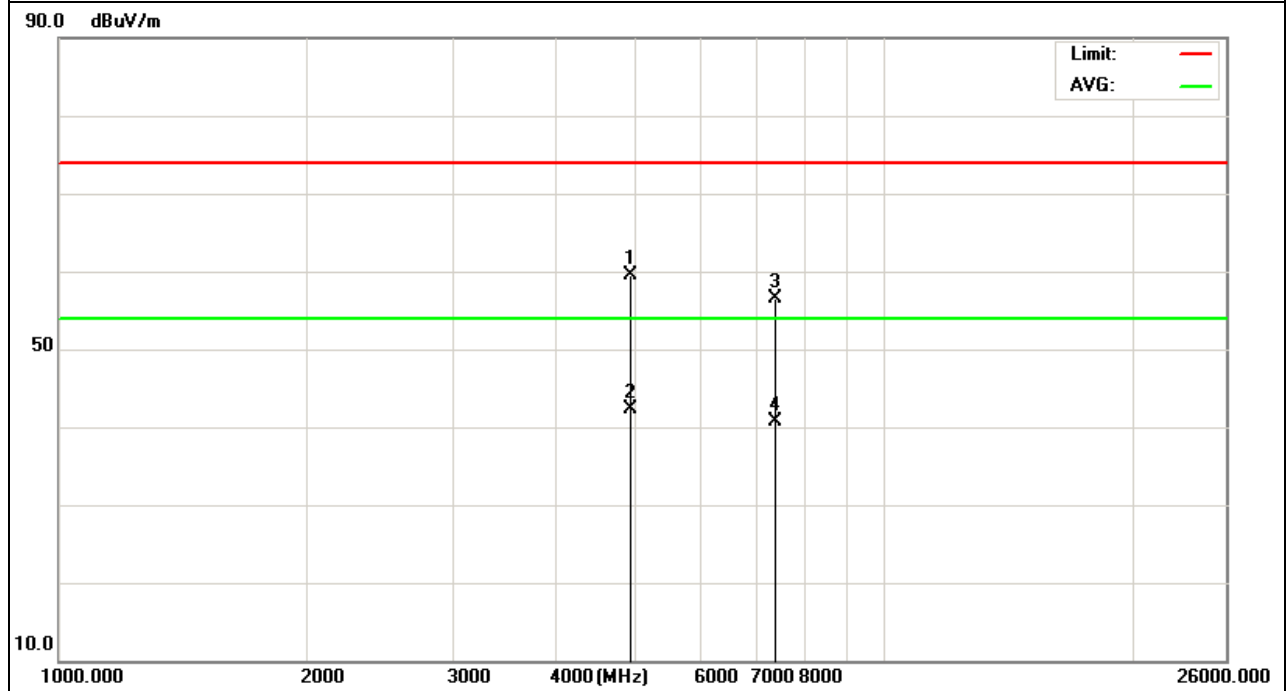

EUT :	SMART TV BOX	Model Name :	Q10
Temperature :	20 °C	Relative Humidity :	48%
Pressure :	1010 hPa	Test Voltage :	DC 12V from adapter AC 120V/60Hz
Test Mode :	CH3(802.11n Mode)/40MHz	Polarization :	Horizontal

Frequency (MHz)	Meter Reading (dBµV)	Factor (dB)	Emission Level (dBµV/m)	Limits (dBµV/m)	Margin (dB)	Detector Type
4844.178	46.95	10.5	57.45	74	-16.55	peak
4844.178	32.12	10.5	42.62	54	-11.38	AVG
7266.344	41.42	12.5	53.92	74	-20.08	peak
7266.344	29.03	12.5	41.53	54	-12.47	AVG

Remark:
Factor = Antenna Factor + Cable Loss – Pre-amplifier.

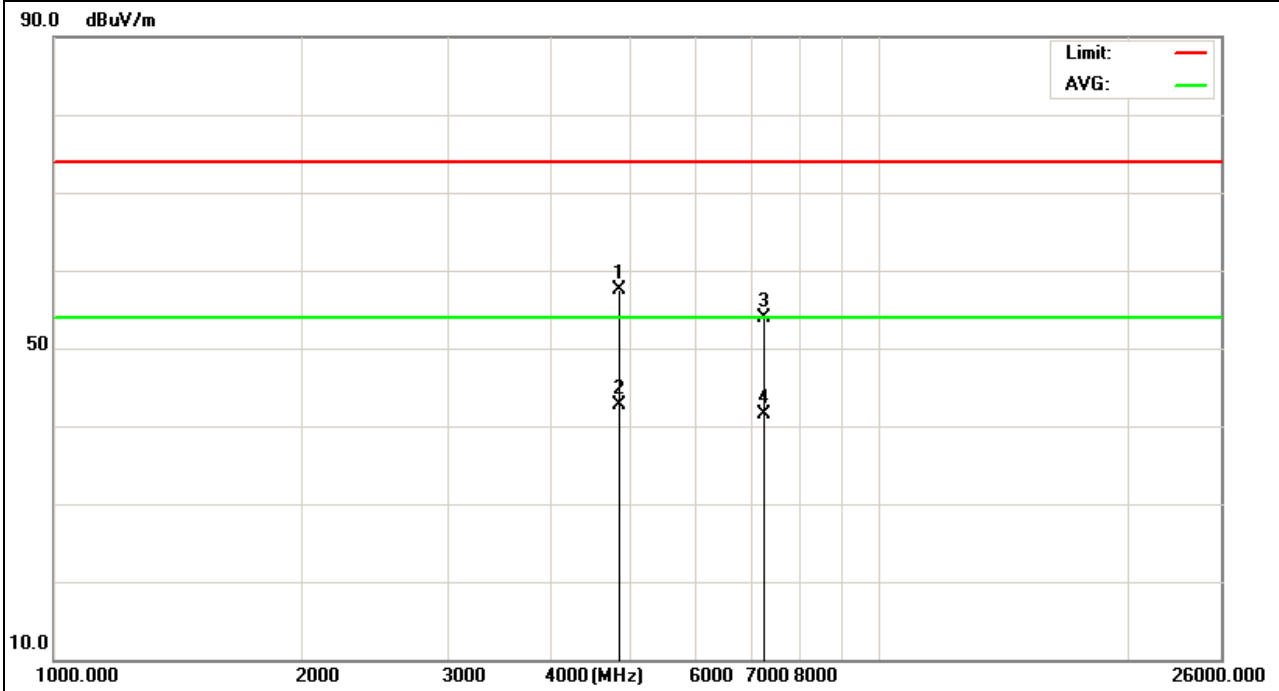

EUT :	SMART TV BOX	Model Name :	Q10
Temperature :	20 °C	Relative Humidity :	48%
Pressure :	1010 hPa	Test Voltage :	DC 12V from adapter AC 120V/60Hz
Test Mode :	CH3(802.11n Mode) /40MHz	Polarization :	Vertical

Frequency (MHz)	Meter Reading (dBµV)	Factor (dB)	Emission Level (dBµV/m)	Limits (dBµV/m)	Margin (dB)	Detector Type
4844.386	45.72	10.5	56.22	74	-17.78	peak
4844.386	31.89	10.5	42.39	54	-11.61	AVG
7266.254	40.91	12.5	53.41	74	-20.59	peak
7266.254	28.8	12.5	41.3	54	-12.7	AVG

Remark:
Factor = Antenna Factor + Cable Loss – Pre-amplifier.

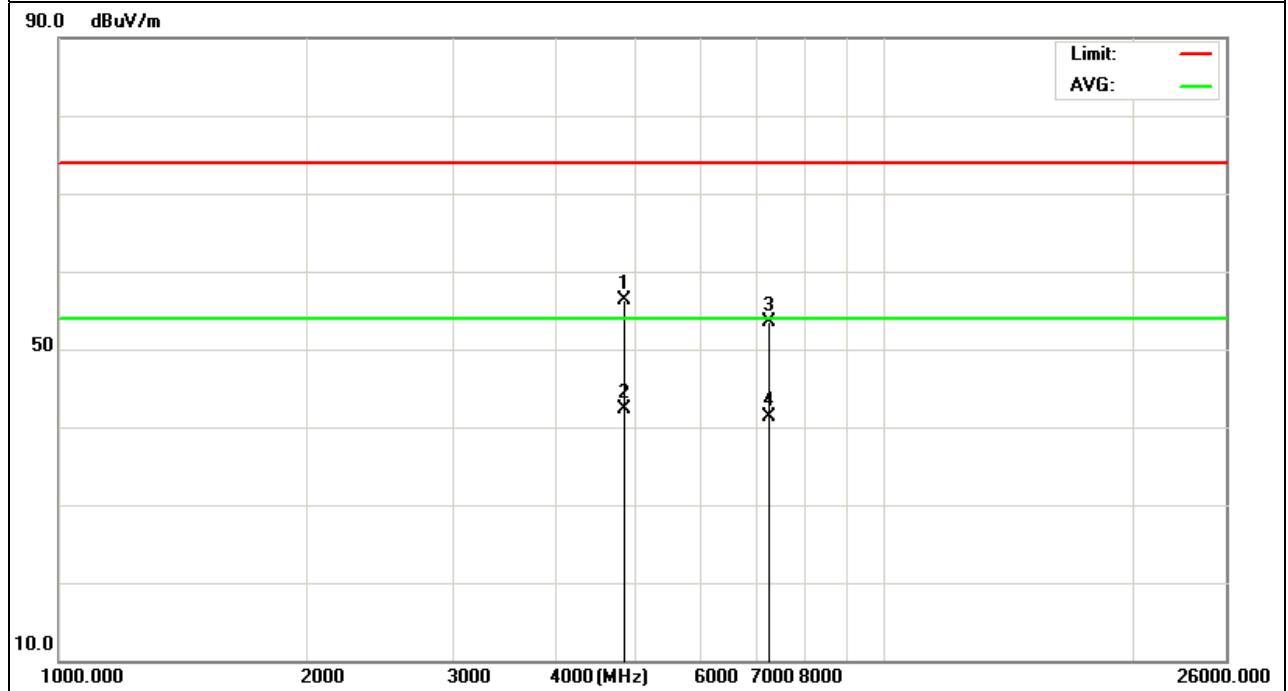

EUT :	SMART TV BOX	Model Name :	Q10
Temperature :	20 °C	Relative Humidity :	48%
Pressure :	1010 hPa	Test Voltage :	DC 12V from adapter AC 120V/60Hz
Test Mode :	CH6(802.11n Mode) /40MHz	Polarization :	Horizontal

Frequency (MHz)	Meter Reading (dBμV)	Factor (dB)	Emission Level (dBμV/m)	Limits (dBμV/m)	Margin (dB)	Detector Type
4874.277	47.58	10.4	57.98	74	-16.02	peak
4874.277	32.35	10.4	42.75	54	-11.25	AVG
7311.132	40.88	12.75	53.63	74	-20.37	peak
7311.132	28.72	12.75	41.47	54	-12.53	AVG

Remark:
Factor = Antenna Factor + Cable Loss – Pre-amplifier.

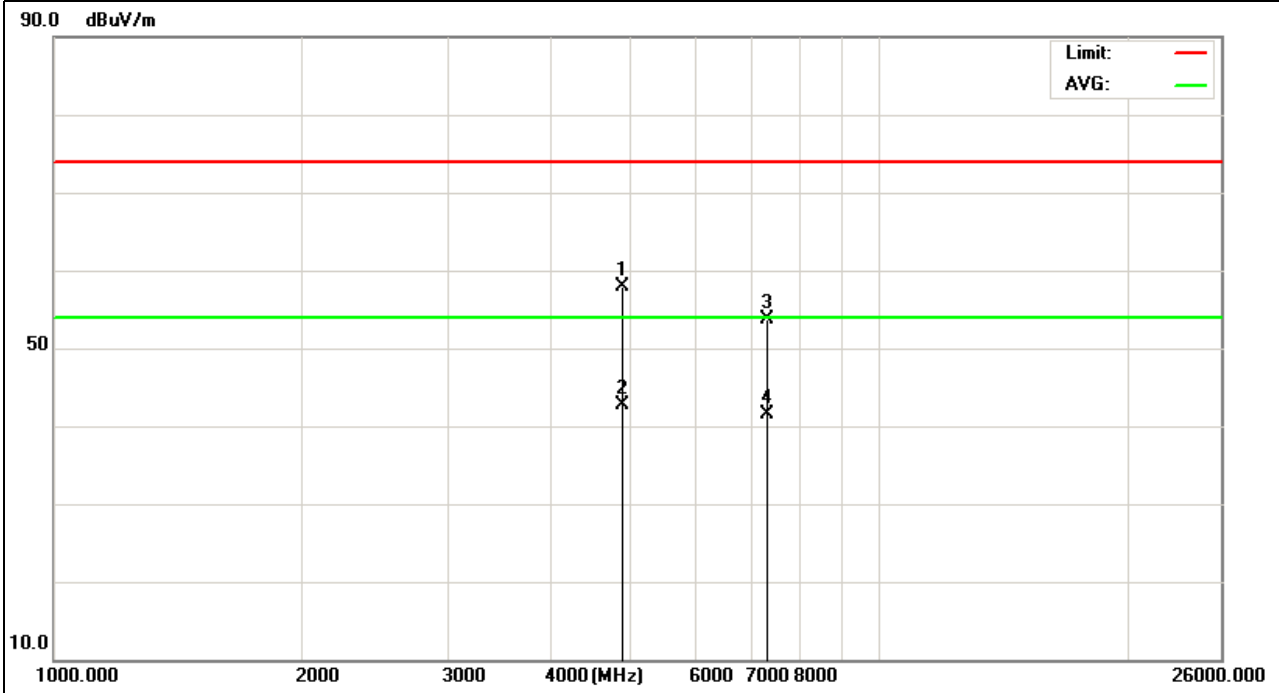

EUT :	SMART TV BOX	Model Name :	Q10
Temperature :	20 °C	Relative Humidity :	48%
Pressure :	1010 hPa	Test Voltage :	DC 12V from adapter AC 120V/60Hz
Test Mode :	CH6(802.11n Mode) /40MHz	Polarization :	Vertical

Frequency (MHz)	Meter Reading (dBµV)	Factor (dB)	Emission Level (dBµV/m)	Limits (dBµV/m)	Margin (dB)	Detector Type
4874.44	47.44	10.4	57.84	74	-16.16	peak
4874.44	33.12	10.4	43.52	54	-10.48	AVG
7311.231	40.91	12.75	53.66	74	-20.34	peak
7311.231	28.76	12.75	41.51	54	-12.49	AVG

Remark:
Factor = Antenna Factor + Cable Loss – Pre-amplifier.

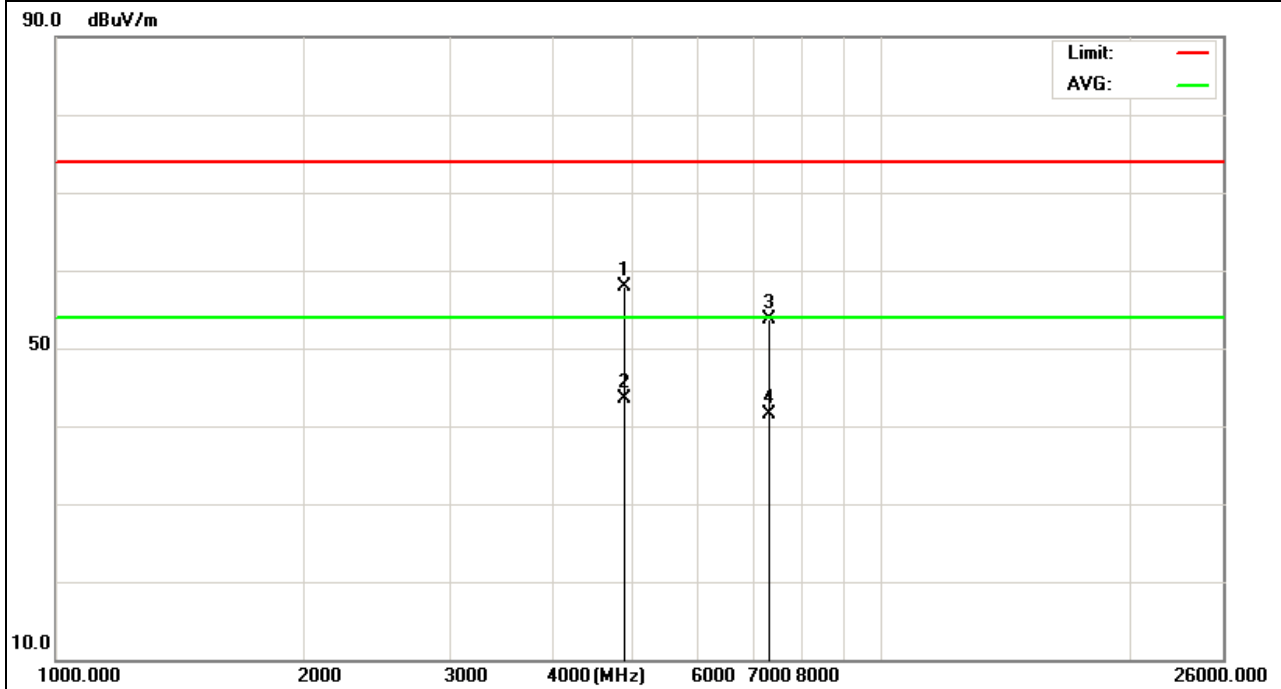

EUT :	SMART TV BOX	Model Name :	Q10
Temperature :	20 °C	Relative Humidity :	48%
Pressure :	1010 hPa	Test Voltage :	DC 12V from adapter AC 120V/60Hz
Test Mode :	CH9(802.11n Mode) /40MHz	Polarization :	Horizontal

Frequency (MHz)	Meter Reading (dBμV)	Factor (dB)	Emission Level (dBμV/m)	Limits (dBμV/m)	Margin (dB)	Detector Type
4904.347	47.58	10.29	57.87	74	-16.13	peak
4904.347	32.06	10.29	42.35	54	-11.65	AVG
7356.269	40.93	12.79	53.72	74	-20.28	peak
7356.269	28.87	12.79	41.66	54	-12.34	AVG

Remark:
Factor = Antenna Factor + Cable Loss – Pre-amplifier.

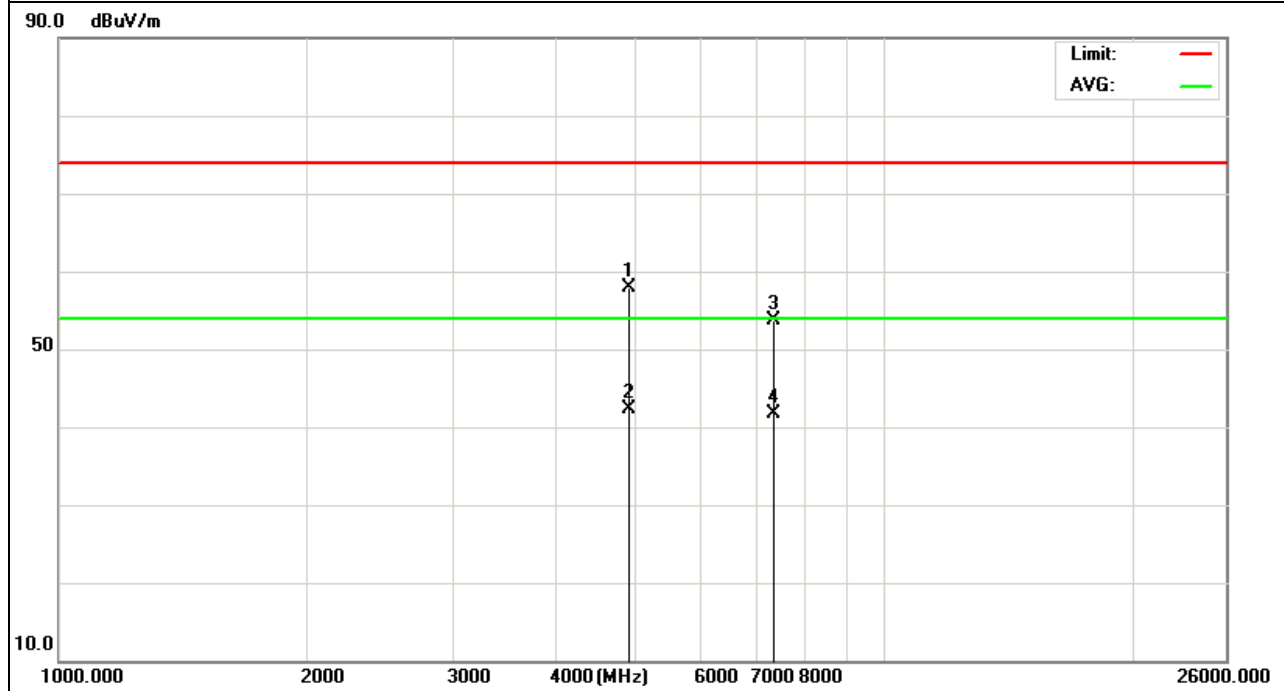

EUT :	SMART TV BOX	Model Name :	Q10
Temperature :	20 °C	Relative Humidity :	48%
Pressure :	1010 hPa	Test Voltage :	DC 12V from adapter AC 120V/60Hz
Test Mode :	CH9(802.11n Mode) /40MHz	Polarization :	Vertical

Frequency (MHz)	Meter Reading (dBμV)	Factor (dB)	Emission Level (dBμV/m)	Limits (dBμV/m)	Margin (dB)	Detector Type
4904.128	47.17	10.29	57.46	74	-16.54	peak
4904.128	32.18	10.29	42.47	54	-11.53	AVG
7356.43	40.47	12.79	53.26	74	-20.74	peak
7356.43	28.76	12.79	41.55	54	-12.45	AVG

Remark:
Factor = Antenna Factor + Cable Loss – Pre-amplifier.

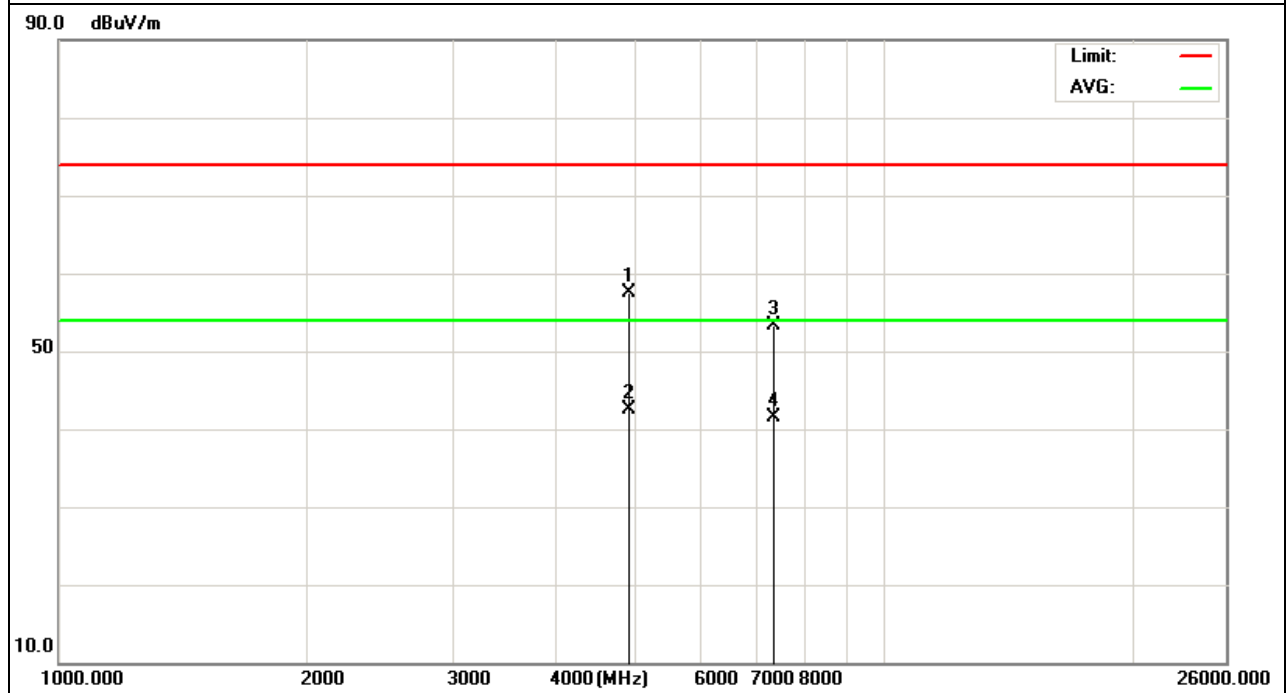

EUT :	SMART TV BOX	Model Name :	Q10
Temperature :	20 °C	Relative Humidity :	48%
Pressure :	1010 hPa	Test Voltage :	DC 12V from adapter AC 120V/60Hz
Test Mode :	CH1(802.11b Mode)	Polarization :	Horizontal

Frequency (MHz)	Meter Reading (dBμV)	Factor (dB)	Emission Level (dBμV/m)	Limits (dBμV/m)	Margin (dB)	Detector Type
2397.1	85.43	-13.02	72.41	74	-1.59	peak
2397.1	60.13	-13.02	47.11	54	-6.89	AVG
2400	81.53	-12.99	68.54	74	-5.46	peak
2400	58.23	-12.99	45.24	54	-8.76	AVG

Remark:
Factor = Antenna Factor + Cable Loss – Pre-amplifier.

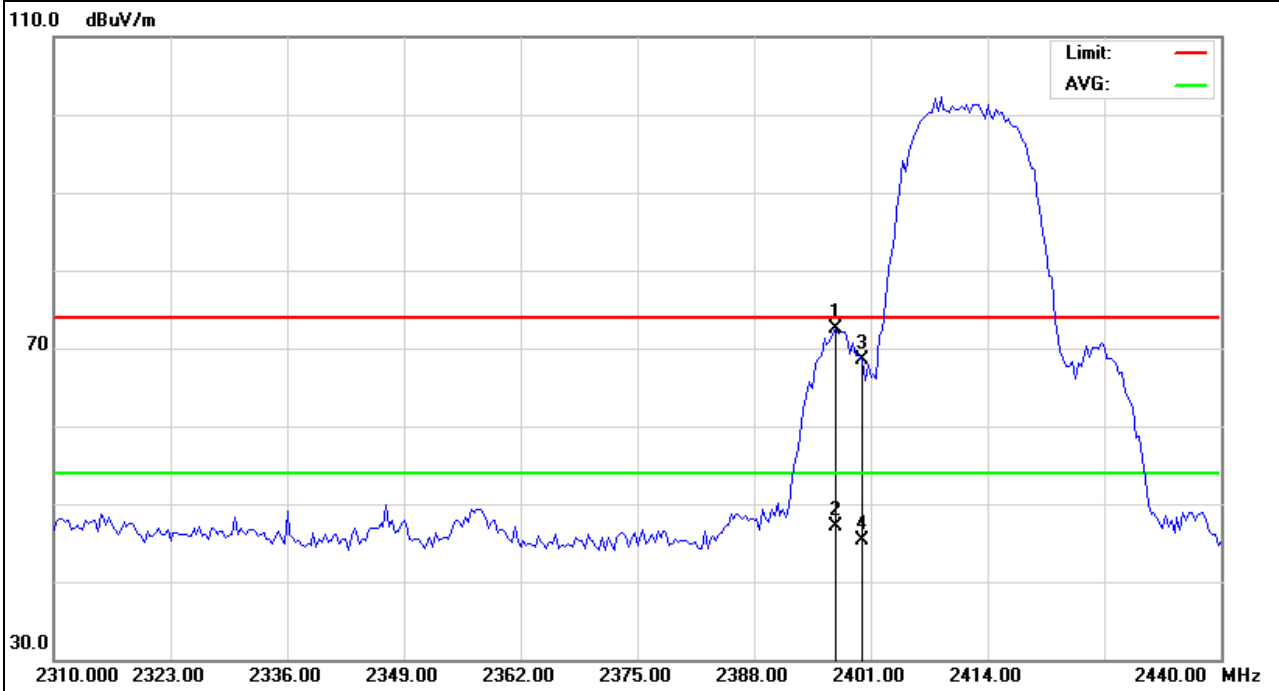

EUT :	SMART TV BOX	Model Name :	Q10
Temperature :	20 °C	Relative Humidity :	48%
Pressure :	1010 hPa	Test Voltage :	DC 12V from adapter AC 120V/60Hz
Test Mode :	CH1(802.11b Mode)	Polarization :	Vertical

Frequency (MHz)	Meter Reading (dBμV)	Factor (dB)	Emission Level (dBμV/m)	Limits (dBμV/m)	Margin (dB)	Detector Type
2397.75	77.73	-13	64.73	74	-9.27	peak
2397.75	60.29	-13	47.29	54	-6.71	AVG
2400	74.04	-12.99	61.05	74	-12.95	peak
2400	58.6	-12.99	45.61	54	-8.39	AVG

Remark:
Factor = Antenna Factor + Cable Loss – Pre-amplifier.

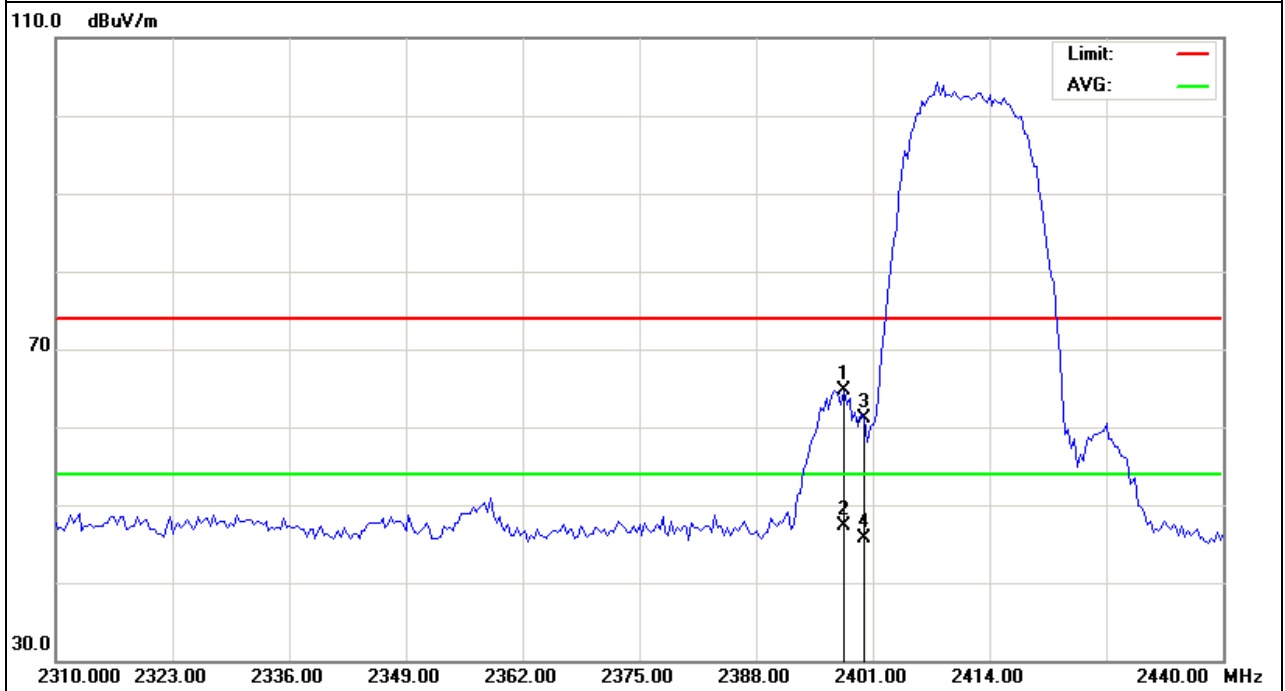

EUT :	SMART TV BOX	Model Name :	Q10
Temperature :	20 °C	Relative Humidity :	48%
Pressure :	1010 hPa	Test Voltage :	DC 12V from adapter AC 120V/60Hz
Test Mode :	CH11(802.11b Mode)	Polarization :	Horizontal

Frequency (MHz)	Meter Reading (dBμV)	Factor (dB)	Emission Level (dBμV/m)	Limits (dBμV/m)	Margin (dB)	Detector Type
2483.5	74.96	-12.78	62.18	74	-11.82	peak
2483.5	60.41	-12.78	47.63	54	-6.37	AVG

Remark:
Factor = Antenna Factor + Cable Loss – Pre-amplifier.

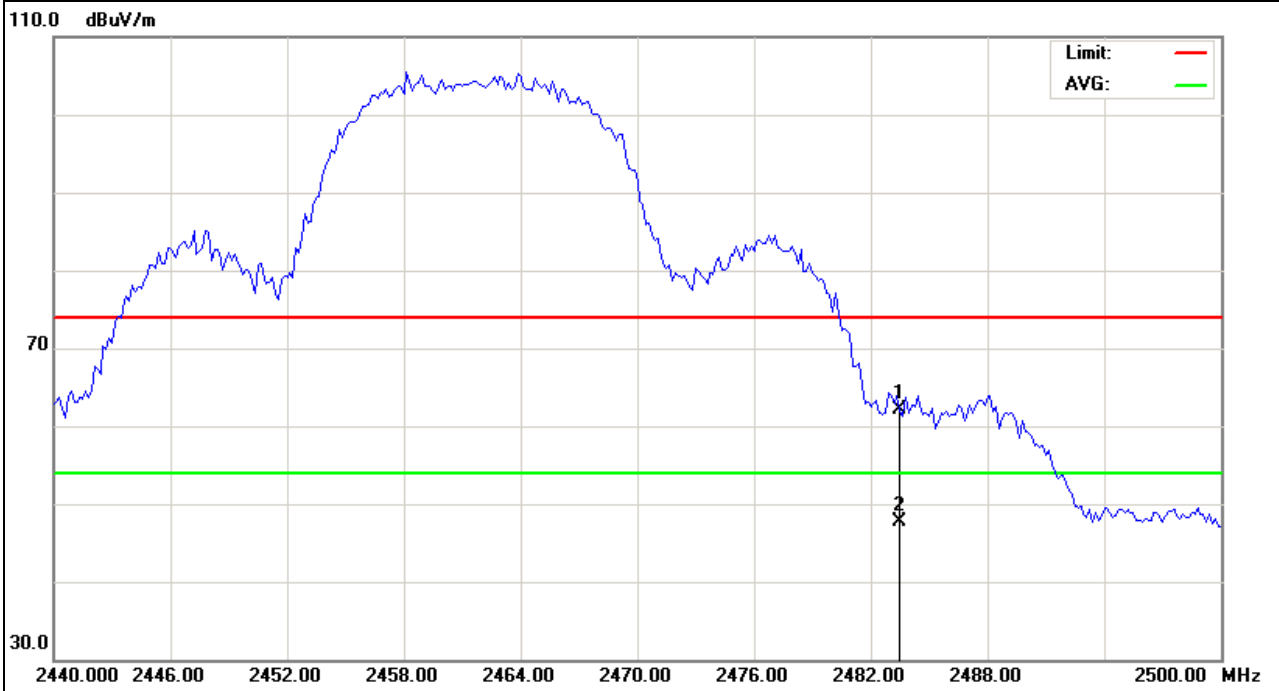

EUT :	SMART TV BOX	Model Name :	Q10
Temperature :	20 °C	Relative Humidity :	48%
Pressure :	1010 hPa	Test Voltage :	DC 12V from adapter AC 120V/60Hz
Test Mode :	CH11(802.11b Mode)	Polarization :	Vertical

Frequency (MHz)	Meter Reading (dBμV)	Factor (dB)	Emission Level (dBμV/m)	Limits (dBμV/m)	Margin (dB)	Detector Type
2483.5	77.37	-12.78	64.59	74	-9.41	peak
2483.5	59.13	-12.78	46.35	54	-7.65	AVG

Remark:
Factor = Antenna Factor + Cable Loss – Pre-amplifier.

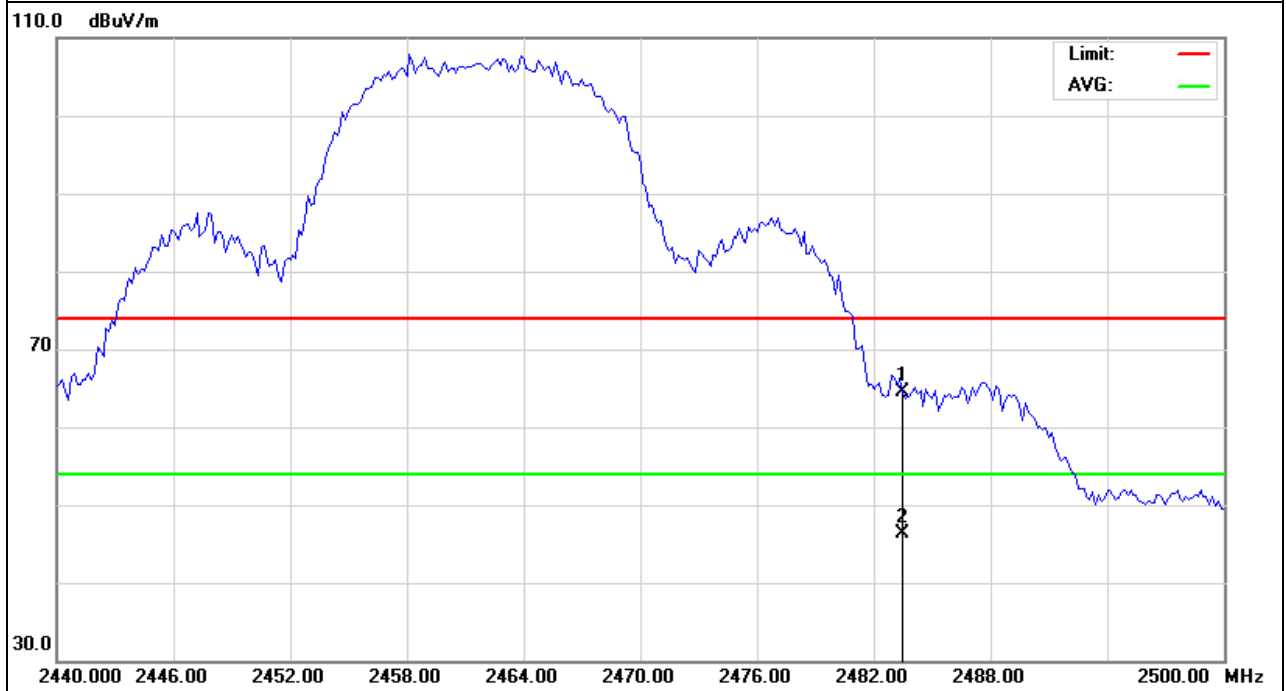

EUT :	SMART TV BOX	Model Name :	Q10
Temperature :	20 °C	Relative Humidity :	48%
Pressure :	1010 hPa	Test Voltage :	DC 12V from adapter AC 120V/60Hz
Test Mode :	CH1(802.11g Mode)	Polarization :	Horizontal

Frequency (MHz)	Meter Reading (dBμV)	Factor (dB)	Emission Level (dBμV/m)	Limits (dBμV/m)	Margin (dB)	Detector Type
2400	82.15	-12.99	69.16	74	-4.84	peak
2400	60.29	-12.99	47.3	54	-6.7	AVG

Remark:
Factor = Antenna Factor + Cable Loss – Pre-amplifier.

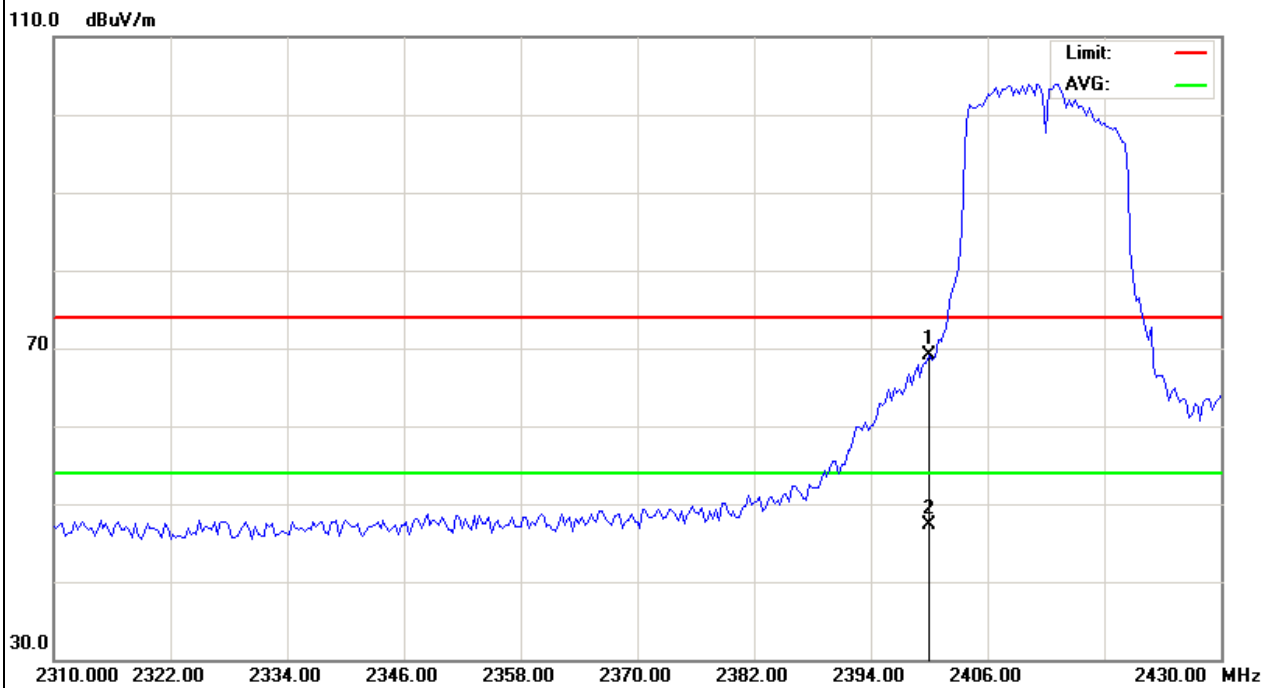

EUT :	SMART TV BOX	Model Name :	Q10
Temperature :	20 °C	Relative Humidity :	48%
Pressure :	1010 hPa	Test Voltage :	DC 12V from adapter AC 120V/60Hz
Test Mode :	CH1(802.11gMode)	Polarization :	Vertical

Frequency (MHz)	Meter Reading (dBμV)	Factor (dB)	Emission Level (dBμV/m)	Limits (dBμV/m)	Margin (dB)	Detector Type
2400	82.05	-12.99	69.06	74	-4.94	peak

Remark:
Factor = Antenna Factor + Cable Loss – Pre-amplifier.

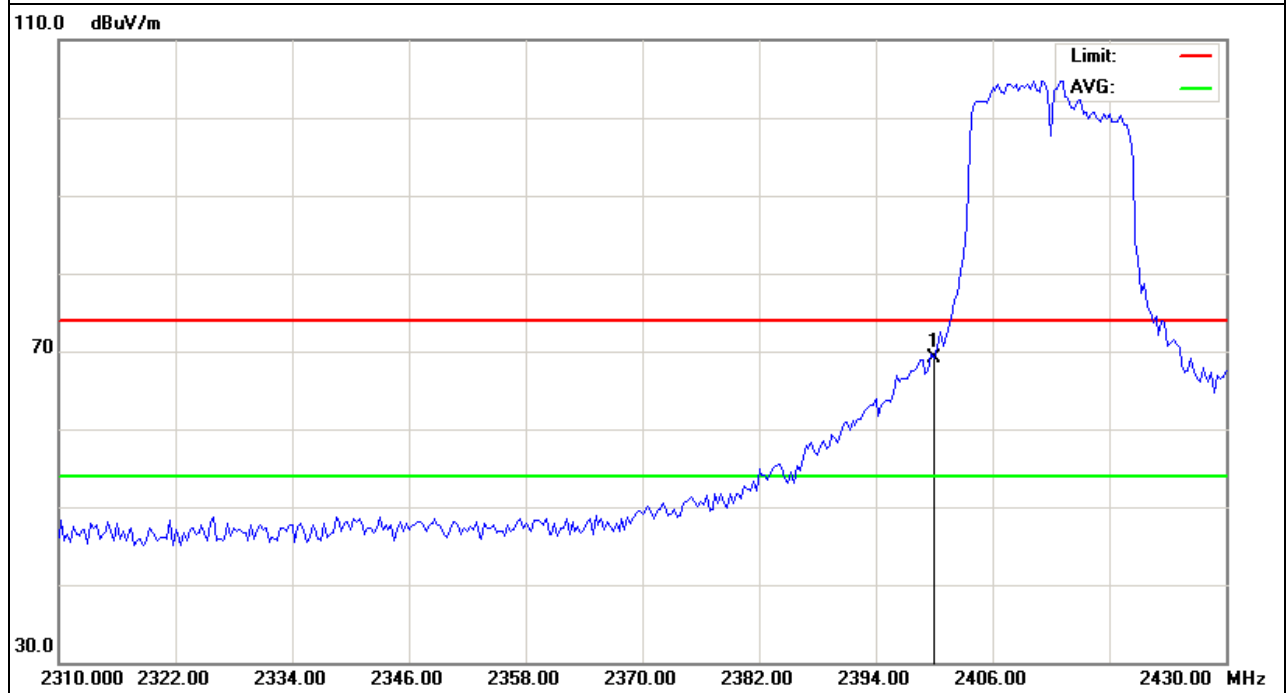

EUT :	SMART TV BOX	Model Name :	Q10
Temperature :	20 °C	Relative Humidity :	48%
Pressure :	1010 hPa	Test Voltage :	DC 12V from adapter AC 120V/60Hz
Test Mode :	CH11(802.11g Mode)	Polarization :	Horizontal

Frequency (MHz)	Meter Reading (dBμV)	Factor (dB)	Emission Level (dBμV/m)	Limits (dBμV/m)	Margin (dB)	Detector Type
2483.5	61.54	-12.78	48.76	74	-25.24	peak

Remark:
Factor = Antenna Factor + Cable Loss – Pre-amplifier.

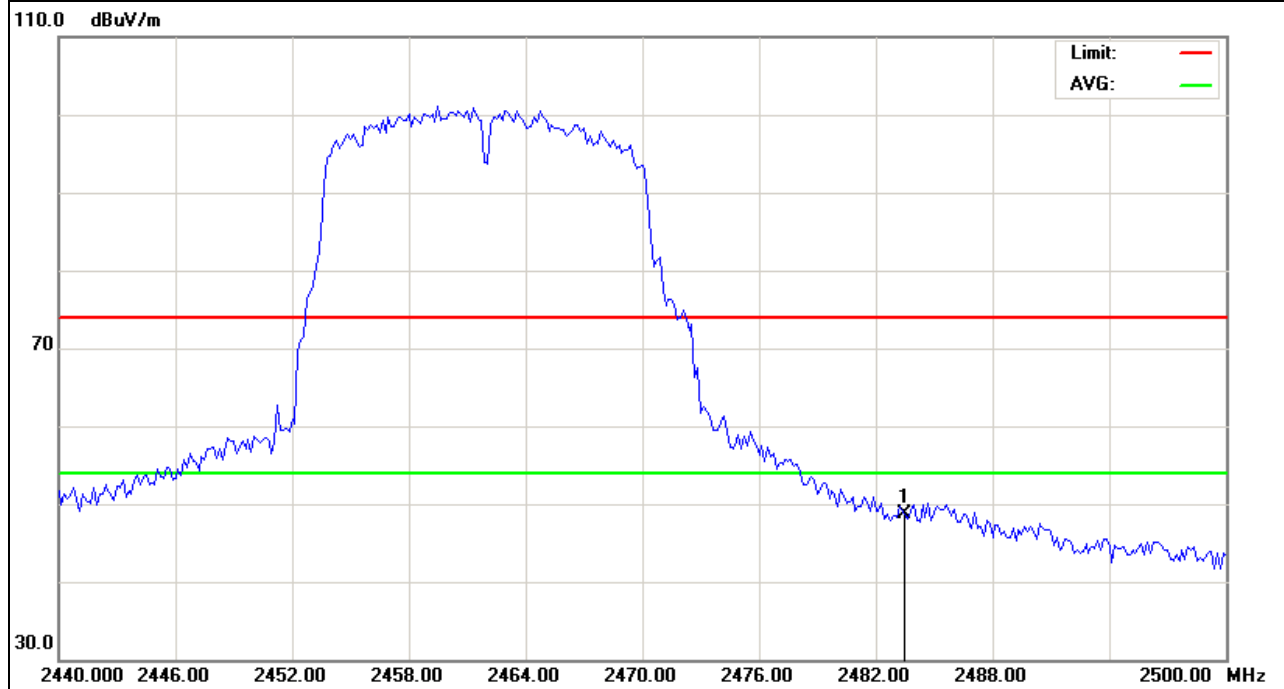

EUT :	SMART TV BOX	Model Name :	Q10
Temperature :	20 °C	Relative Humidity :	48%
Pressure :	1010 hPa	Test Voltage :	DC 12V from adapter AC 120V/60Hz
Test Mode :	CH11(802.11g Mode)	Polarization :	Vertical

Frequency (MHz)	Meter Reading (dBμV)	Factor (dB)	Emission Level (dBμV/m)	Limits (dBμV/m)	Margin (dB)	Detector Type
2483.5	63.94	-12.78	51.16	74	-22.84	peak

Remark:
Factor = Antenna Factor + Cable Loss – Pre-amplifier.

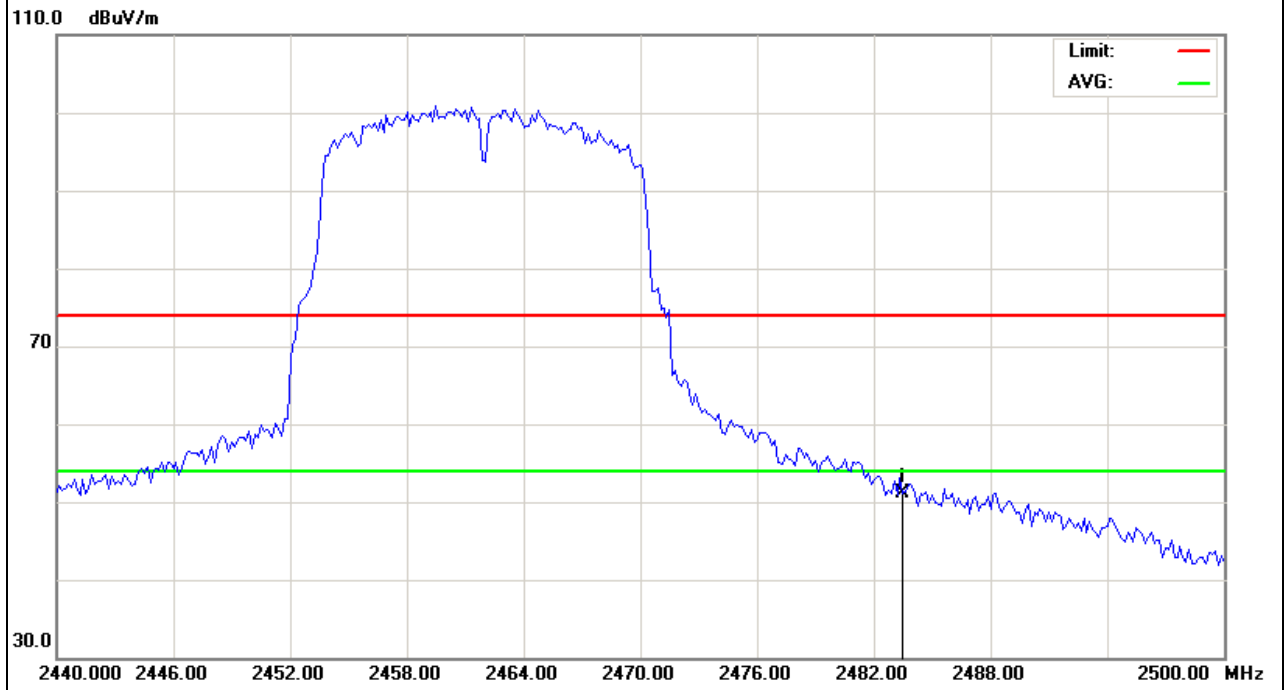

EUT :	SMART TV BOX	Model Name :	Q10
Temperature :	20 °C	Relative Humidity :	48%
Pressure :	1010 hPa	Test Voltage :	DC 12V from adapter AC 120V/60Hz
Test Mode :	CH1(802.11N Mode)	Polarization :	Horizontal

Frequency (MHz)	Meter Reading (dBμV)	Factor (dB)	Emission Level (dBμV/m)	Limits (dBμV/m)	Margin (dB)	Detector Type
2400	73.65	-12.99	60.66	74	-13.34	peak
2400	59.41	-12.99	46.42	54	-7.58	AVG

Remark:
Factor = Antenna Factor + Cable Loss – Pre-amplifier.

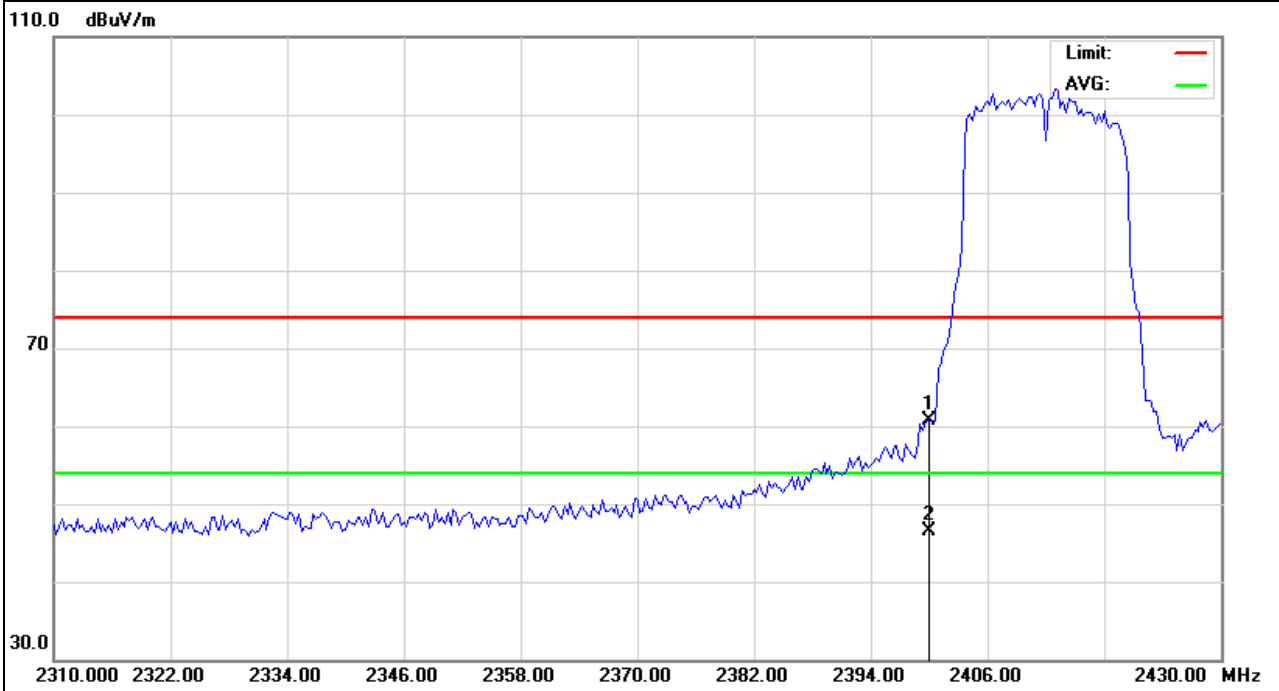

EUT :	SMART TV BOX	Model Name :	Q10
Temperature :	20 °C	Relative Humidity :	48%
Pressure :	1010 hPa	Test Voltage :	DC 12V from adapter AC 120V/60Hz
Test Mode :	CH1(802.11N Mode)	Polarization :	Vertical

Frequency (MHz)	Meter Reading (dBμV)	Factor (dB)	Emission Level (dBμV/m)	Limits (dBμV/m)	Margin (dB)	Detector Type
2400	74.45	-12.99	61.46	74	-12.54	peak
2400	60.18	-12.99	47.19	54	-6.81	AVG

Remark:
Factor = Antenna Factor + Cable Loss – Pre-amplifier.

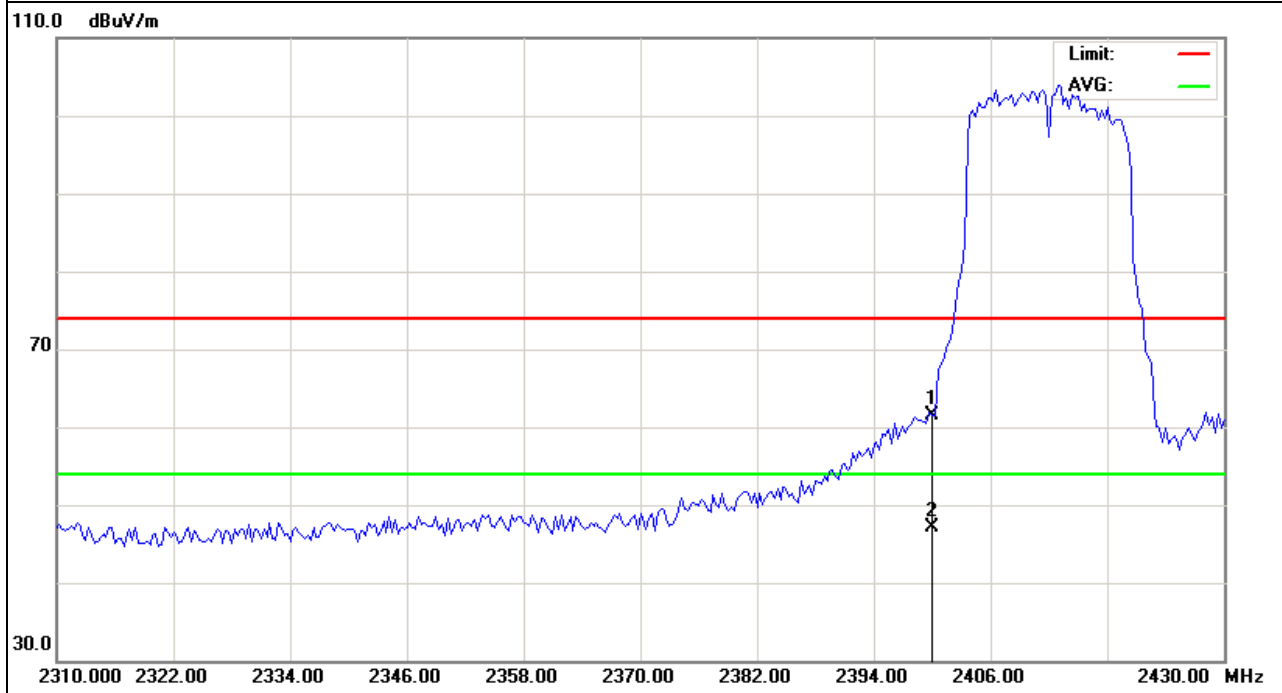

EUT :	SMART TV BOX	Model Name :	Q10
Temperature :	20 °C	Relative Humidity :	48%
Pressure :	1010 hPa	Test Voltage :	DC 12V from adapter AC 120V/60Hz
Test Mode :	CH11(802.11N Mode)	Polarization :	Horizontal

Frequency (MHz)	Meter Reading (dBμV)	Factor (dB)	Emission Level (dBμV/m)	Limits (dBμV/m)	Margin (dB)	Detector Type
2483.5	72.54	-12.78	59.76	74	-14.24	peak
2483.5	58.8	-12.78	46.02	54	-7.98	AVG

Remark:
Factor = Antenna Factor + Cable Loss – Pre-amplifier.

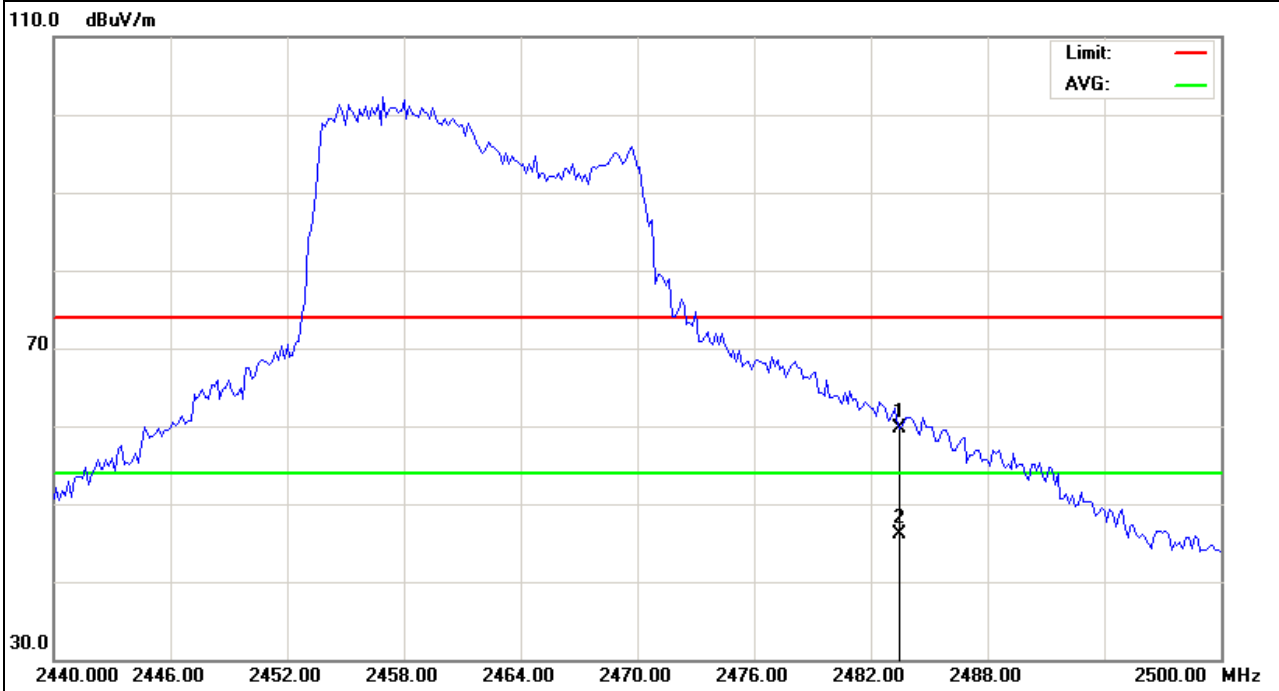

EUT :	SMART TV BOX	Model Name :	Q10
Temperature :	20 °C	Relative Humidity :	48%
Pressure :	1010 hPa	Test Voltage :	DC 12V from adapter AC 120V/60Hz
Test Mode :	CH11(802.11N Mode)	Polarization :	Vertical

Frequency (MHz)	Meter Reading (dBμV)	Factor (dB)	Emission Level (dBμV/m)	Limits (dBμV/m)	Margin (dB)	Detector Type
2483.5	72.44	-12.78	59.66	74	-14.34	peak
2483.5	59.88	-12.78	47.1	54	-6.9	AVG

Remark:
Factor = Antenna Factor + Cable Loss – Pre-amplifier.

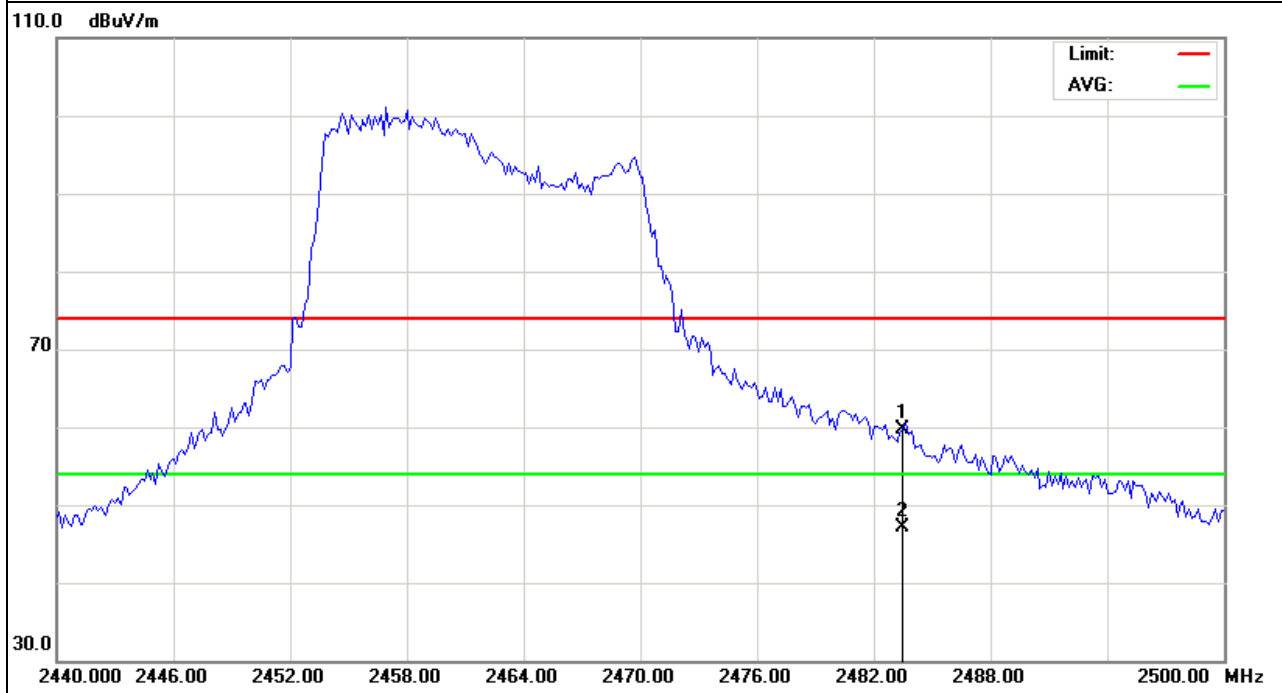

EUT :	SMART TV BOX	Model Name :	Q10
Temperature :	20 °C	Relative Humidity :	48%
Pressure :	1010 hPa	Test Voltage :	DC 12V from adapter AC 120V/60Hz
Test Mode :	CH3(802.11n Mode)/40MHz	Polarization :	Horizontal

Frequency (MHz)	Meter Reading (dBμV)	Factor (dB)	Emission Level (dBμV/m)	Limits (dBμV/m)	Margin (dB)	Detector Type
2400	79.4	-12.99	66.41	74	-7.59	peak
2400	61.31	-12.99	48.32	54	-5.68	AVG

Remark:
Factor = Antenna Factor + Cable Loss – Pre-amplifier.

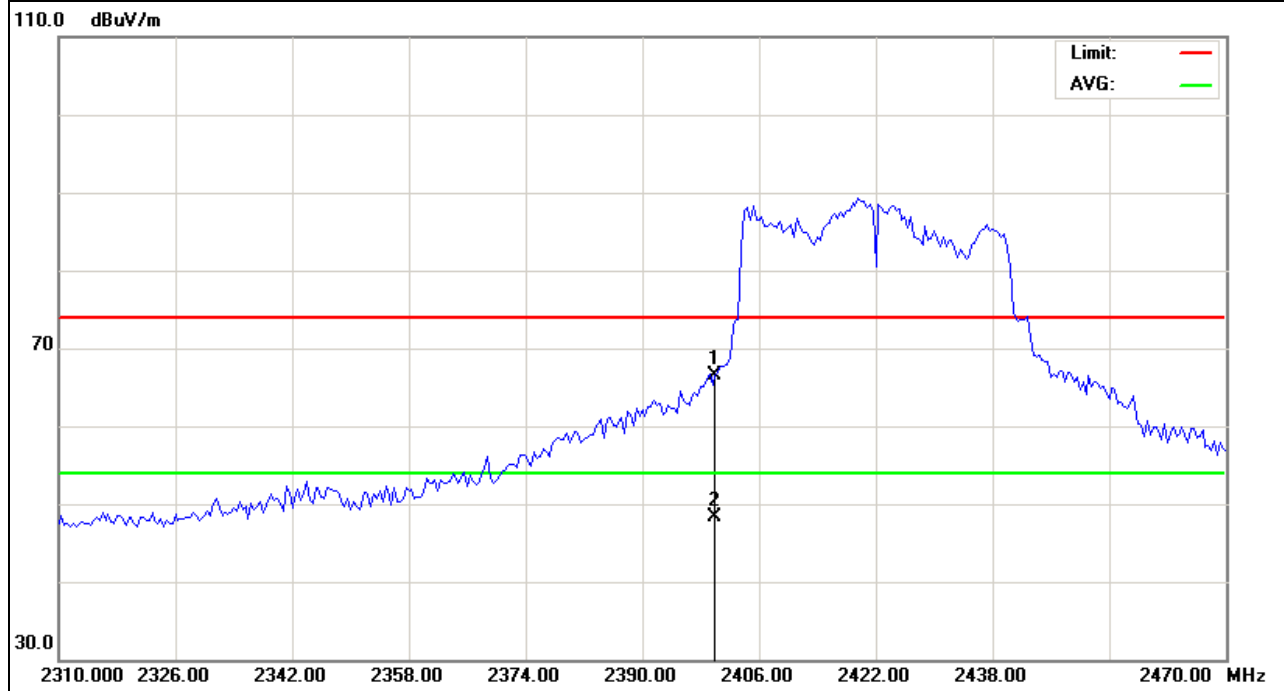

EUT :	SMART TV BOX	Model Name :	Q10
Temperature :	20 °C	Relative Humidity :	48%
Pressure :	1010 hPa	Test Voltage :	DC 12V from adapter AC 120V/60Hz
Test Mode :	CH3(802.11n Mode) /40MHz	Polarization :	Vertical

Frequency (MHz)	Meter Reading (dBµV)	Factor (dB)	Emission Level (dBµV/m)	Limits (dBµV/m)	Margin (dB)	Detector Type
2400	78.39	-12.99	65.4	74	-8.6	peak
2400	64.45	-12.99	51.46	54	-2.54	AVG

Remark:
Factor = Antenna Factor + Cable Loss – Pre-amplifier.

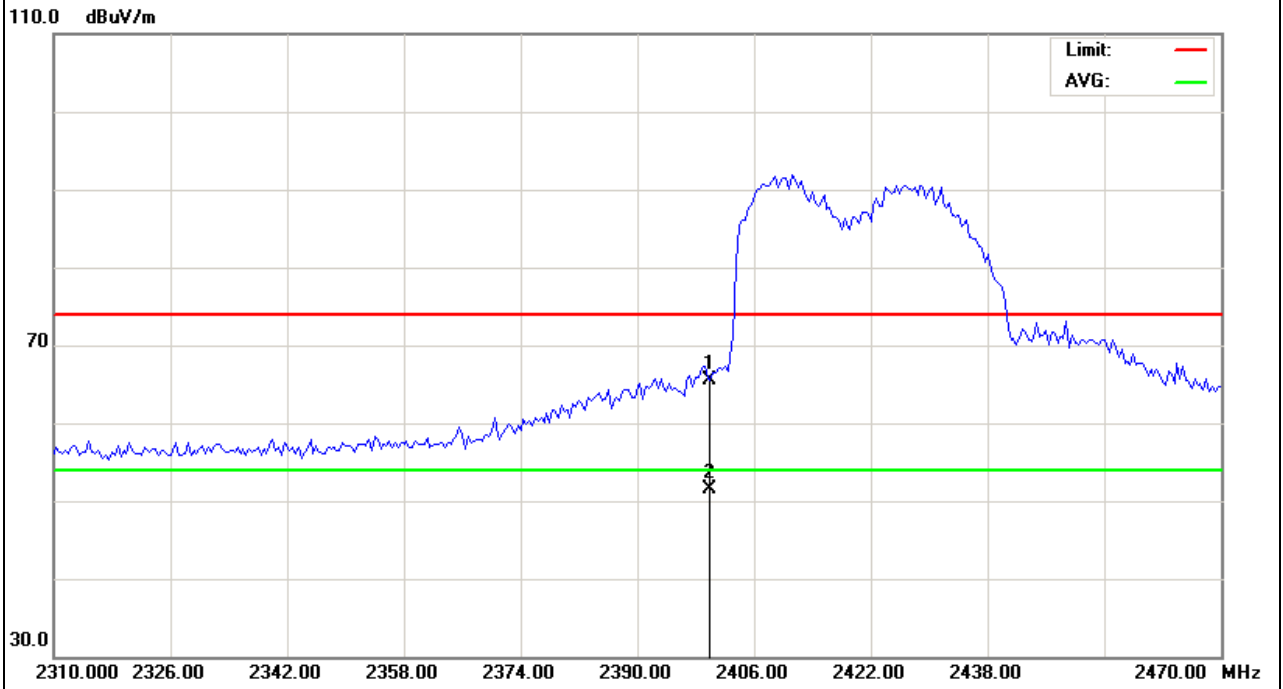

EUT :	SMART TV BOX	Model Name :	Q10
Temperature :	20 °C	Relative Humidity :	48%
Pressure :	1010 hPa	Test Voltage :	DC 12V from adapter AC 120V/60Hz
Test Mode :	CH9(802.11n Mode) /40MHz	Polarization :	Horizontal

Frequency (MHz)	Meter Reading (dBμV)	Factor (dB)	Emission Level (dBμV/m)	Limits (dBμV/m)	Margin (dB)	Detector Type
2483.5	74.28	-12.78	61.5	74	-12.5	peak
2483.5	59.76	-12.78	46.98	54	-7.02	AVG

Remark:
Factor = Antenna Factor + Cable Loss – Pre-amplifier.

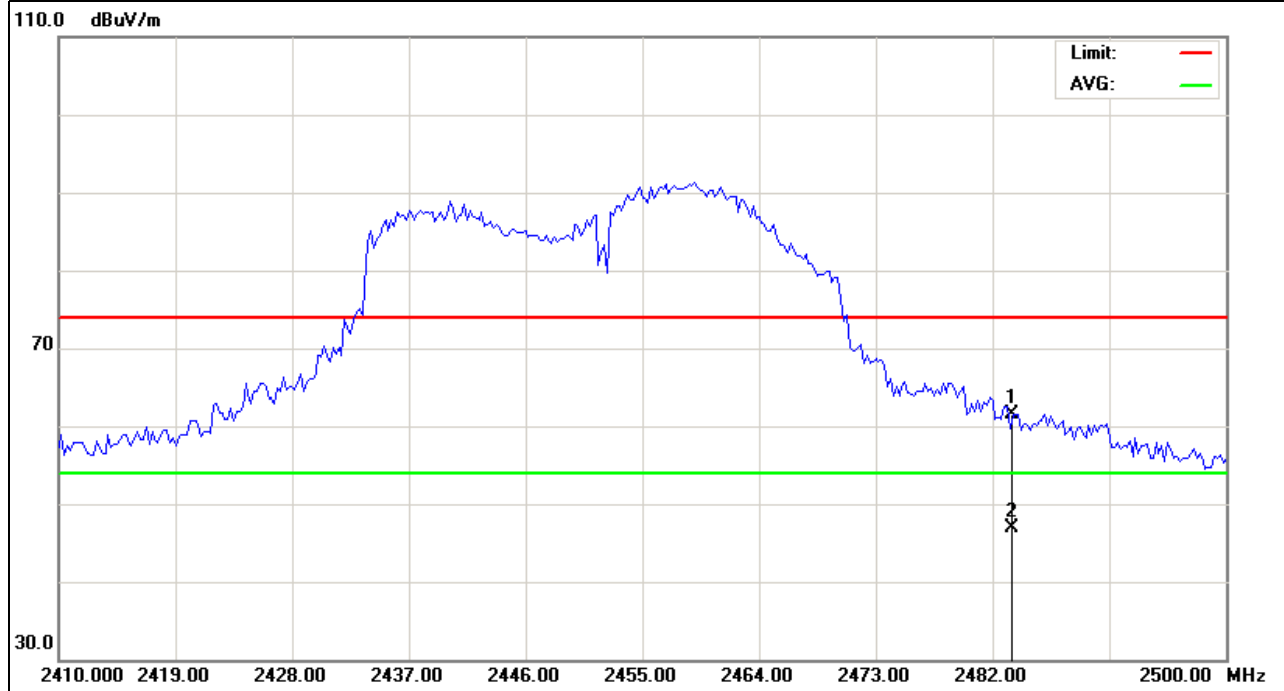

EUT :	SMART TV BOX	Model Name :	Q10
Temperature :	20 °C	Relative Humidity :	48%
Pressure :	1010 hPa	Test Voltage :	DC 12V from adapter AC 120V/60Hz
Test Mode :	CH9(802.11n Mode) /40MHz	Polarization :	Vertical

Frequency (MHz)	Meter Reading (dBμV)	Factor (dB)	Emission Level (dBμV/m)	Limits (dBμV/m)	Margin (dB)	Detector Type
2483.5	76.08	-12.78	63.3	74	-10.7	peak
2483.5	60.51	-12.78	47.73	54	-6.27	AVG

Remark:
Factor = Antenna Factor + Cable Loss – Pre-amplifier.

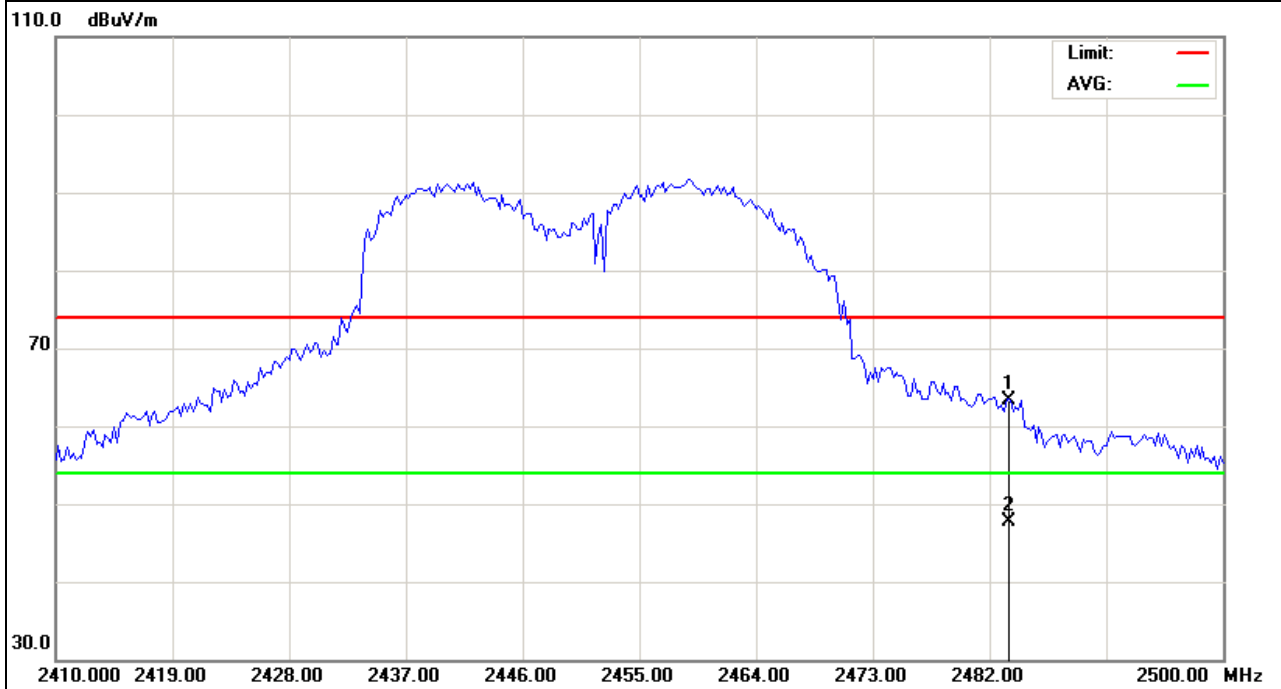

4. POWER SPECTRAL DENSITY TEST

4.1 APPLIED PROCEDURES / LIMIT

FCC Part15 (15.247) , Subpart C				
Section	Test Item	Limit	Frequency Range (MHz)	Result
15.247	Power Spectral Density	8 dBm (in any 3KHz)	2400-2483.5	PASS

4.1.1 TEST PROCEDURE

1. Set analyzer center frequency to DTS channel center frequency.
2. Set the span to 1.5 times the DTS channel bandwidth.
3. Set the RBW \geq 3 kHz.
4. Set the VBW \geq 3 x RBW.
5. Detector = peak.
6. Sweep time = auto couple.
7. Trace mode = max hold.
8. Allow trace to fully stabilize.
9. Use the peak marker function to determine the maximum amplitude level.
10. If measured value exceeds limit, reduce RBW (no less than 3 kHz) and repeat.

4.1.2 DEVIATION FROM STANDARD

No deviation.

4.1.3 TEST SETUP



4.1.4 EUT OPERATION CONDITIONS

The EUT tested system was configured as the statements of 2.1 Unless otherwise a special operating condition is specified in the follows during the testing.

4.1.5 TEST RESULTS

EUT :	SMART TV BOX	Model Name :	Q10
Temperature :	25 °C	Relative Humidity :	60%
Pressure :	1015 hPa	Test Voltage :	DC 12V from adapter AC 120V/60Hz
Test Mode :	TX b Mode /CH01, CH06, CH11		

Frequency	Power Density (dBm)	Limit (dBm)	Result
2412 MHz	-7.76	8	PASS
2437 MHz	-8.30	8	PASS
2462 MHz	-9.14	8	PASS

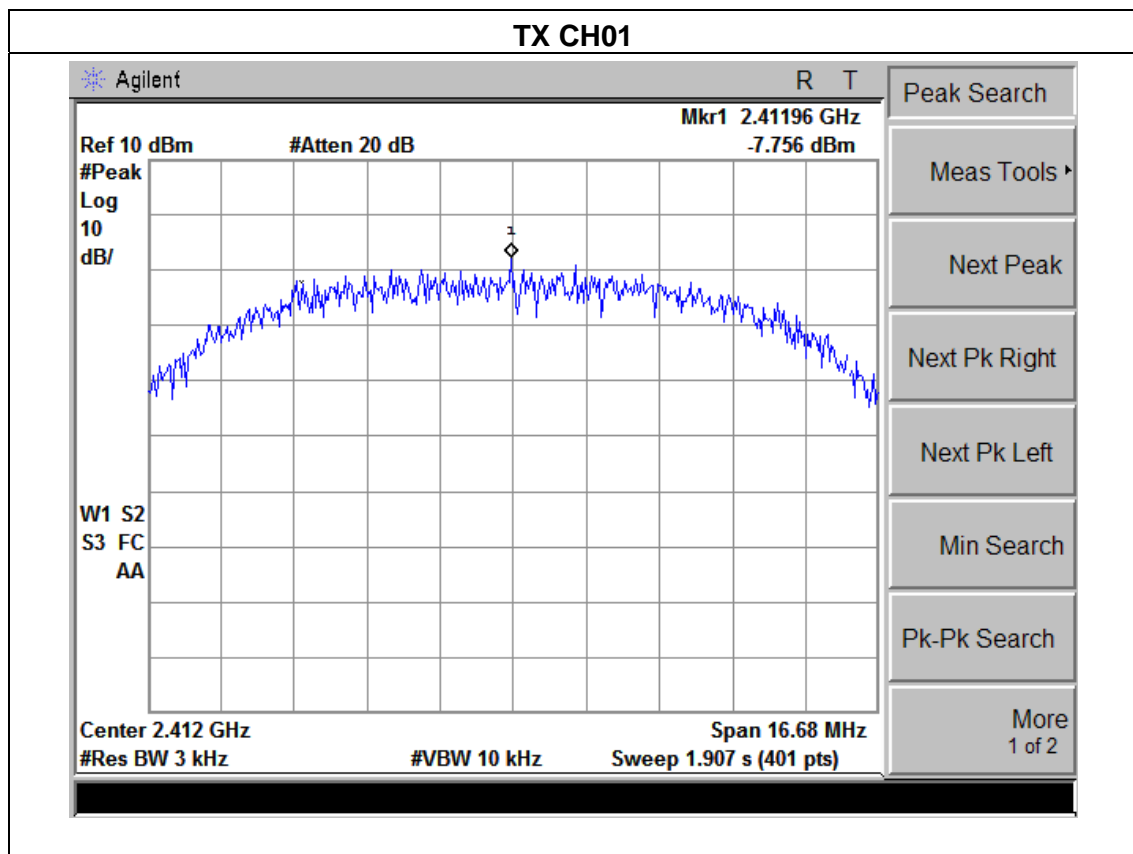

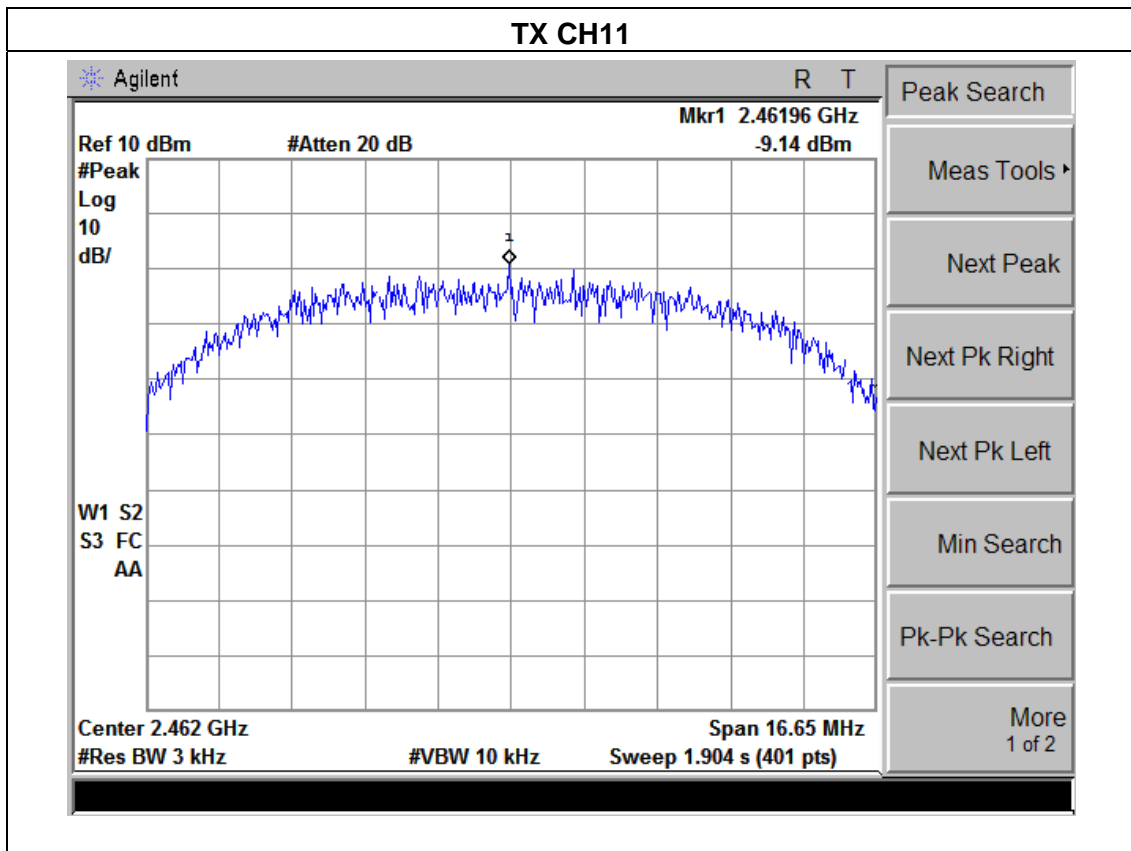
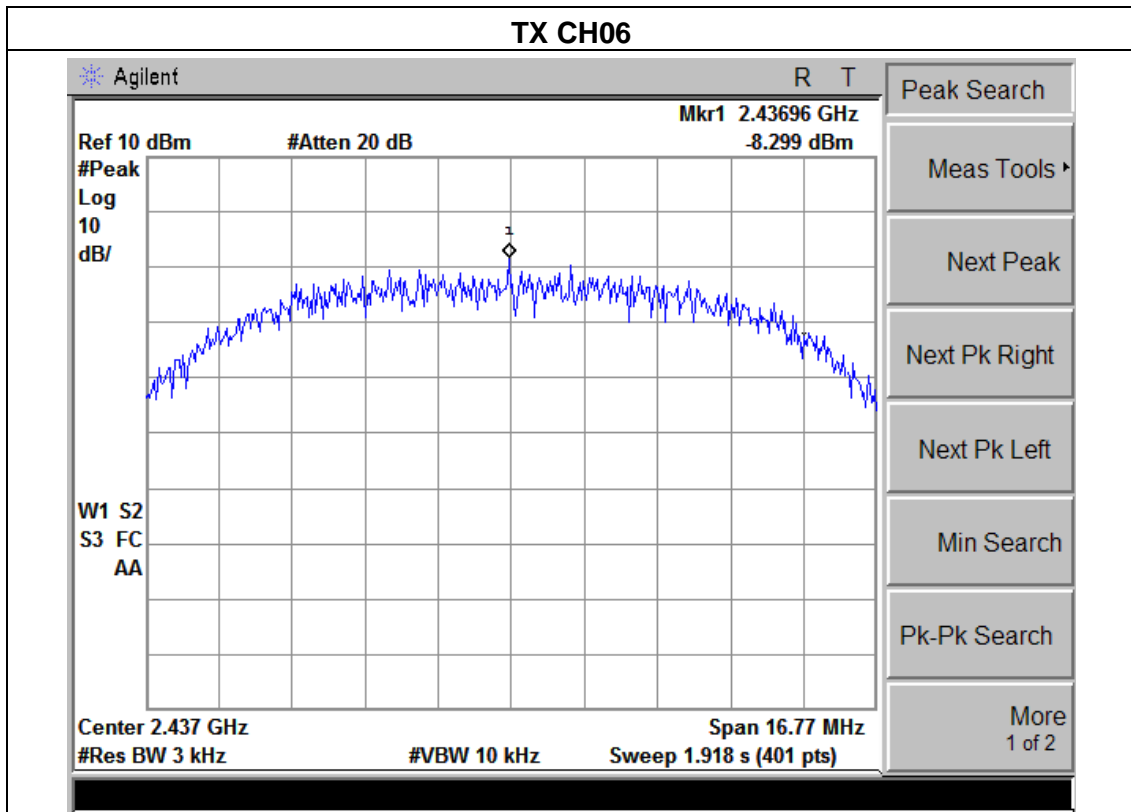

EUT :	SMART TV BOX	Model Name :	Q10
Temperature :	25 °C	Relative Humidity :	60%
Pressure :	1015 hPa	Test Voltage :	DC 12V from adapter AC 120V/60Hz
Test Mode :	TX g Mode /CH01, CH06, CH11		

Frequency	Power Density (dBm)	Limit (dBm)	Result
2412 MHz	-10.21	8	PASS
2437 MHz	-10.93	8	PASS
2462 MHz	-10.87	8	PASS

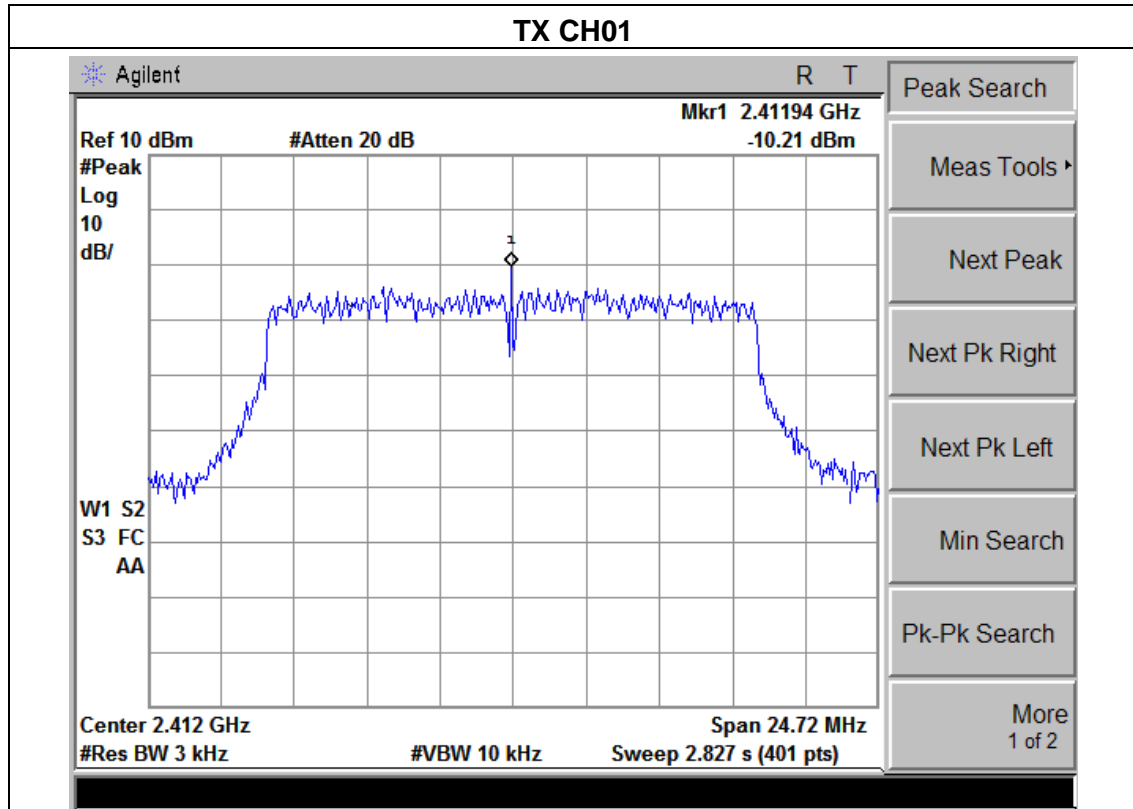

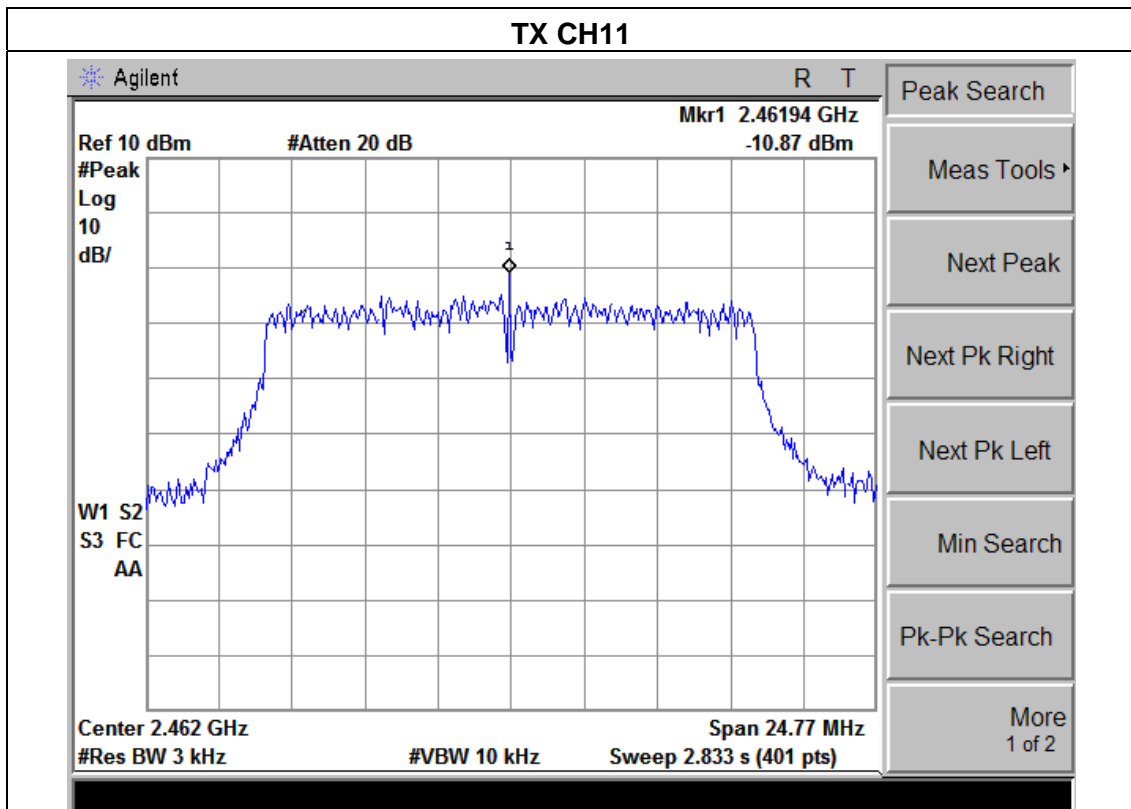
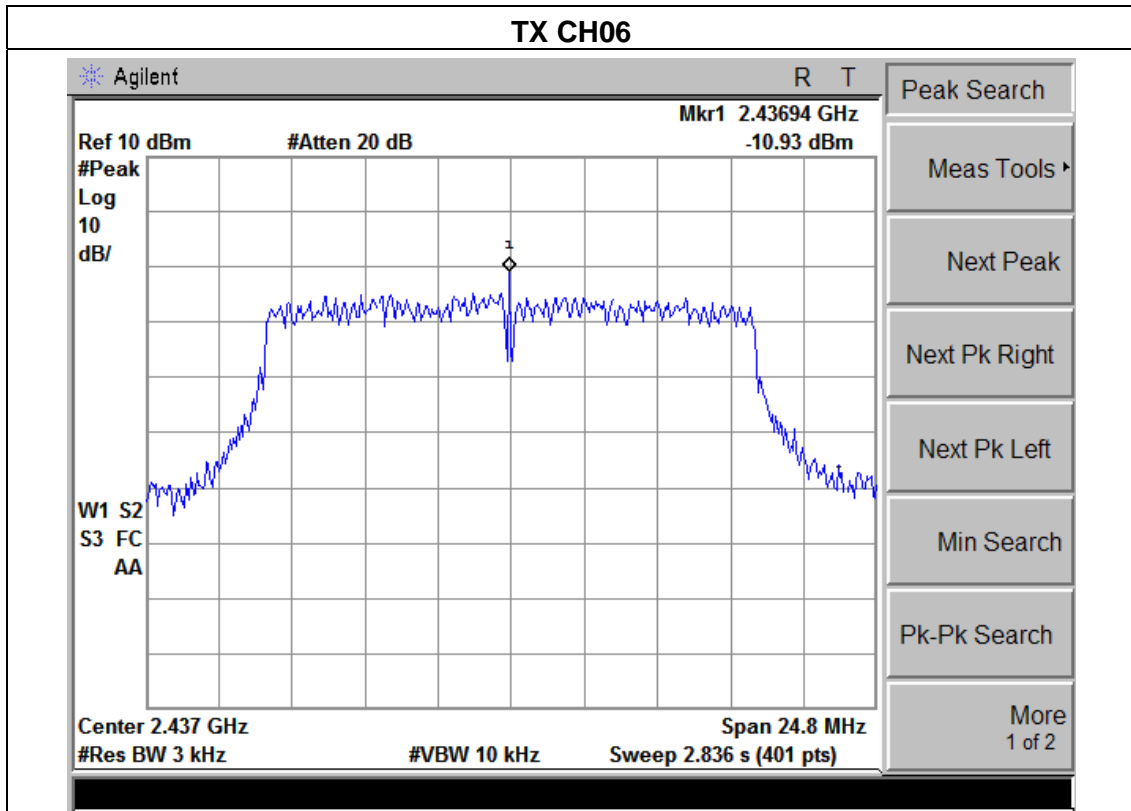

EUT :	SMART TV BOX	Model Name :	Q10
Temperature :	25 °C	Relative Humidity :	60%
Pressure :	1015 hPa	Test Voltage :	DC 12V from adapter AC 120V/60Hz
Test Mode :	TX n(20) Mode /CH01, CH06, CH11		

Frequency	Power Density (dBm)	Limit (dBm)	Result
2412 MHz	-10.34	8	PASS
2437 MHz	-11.21	8	PASS
2462 MHz	-12.43	8	PASS

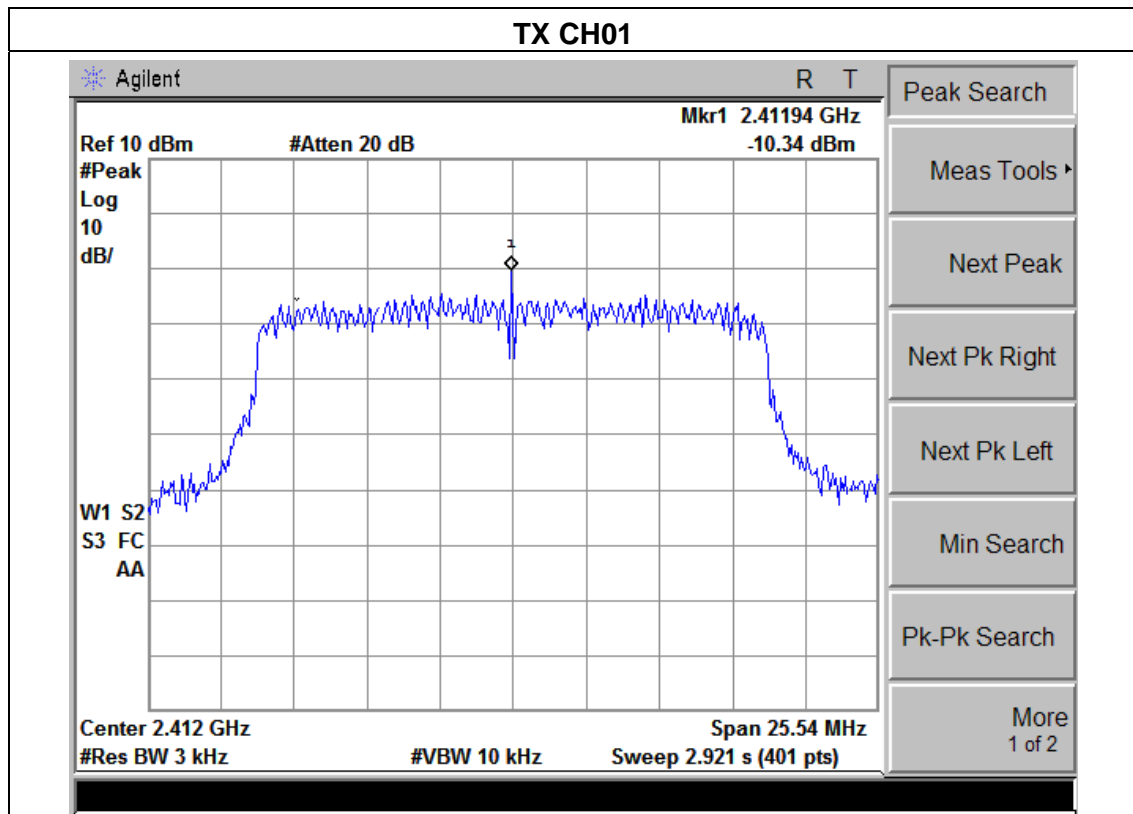

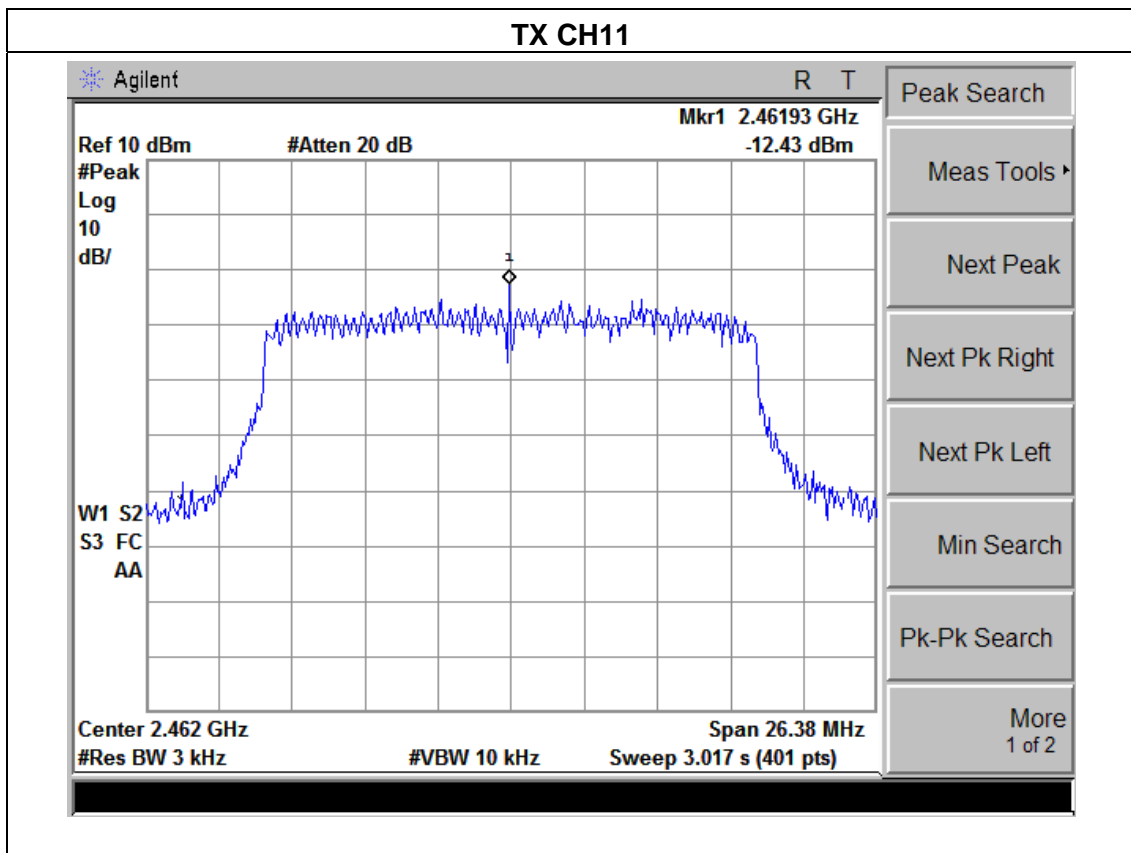
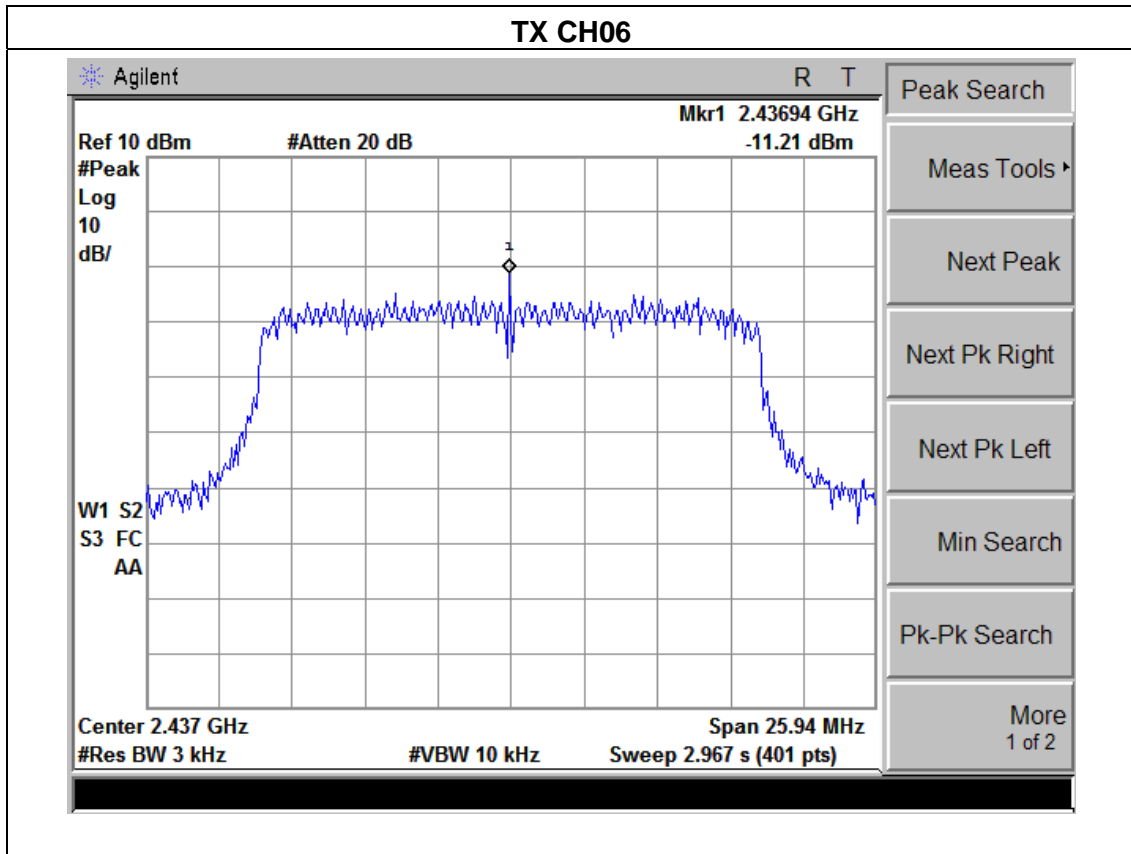

EUT :	SMART TV BOX	Model Name :	Q10
Temperature :	25 °C	Relative Humidity :	60%
Pressure :	1015 hPa	Test Voltage :	DC 12V from adapter AC 120V/60Hz
Test Mode :	TX n(40) Mode /CH03, CH06, CH09		

Frequency	Power Density (dBm)	Limit (dBm)	Result
2422 MHz	-8.54	8	PASS
2437 MHz	-8.65	8	PASS
2452 MHz	-8.67	8	PASS

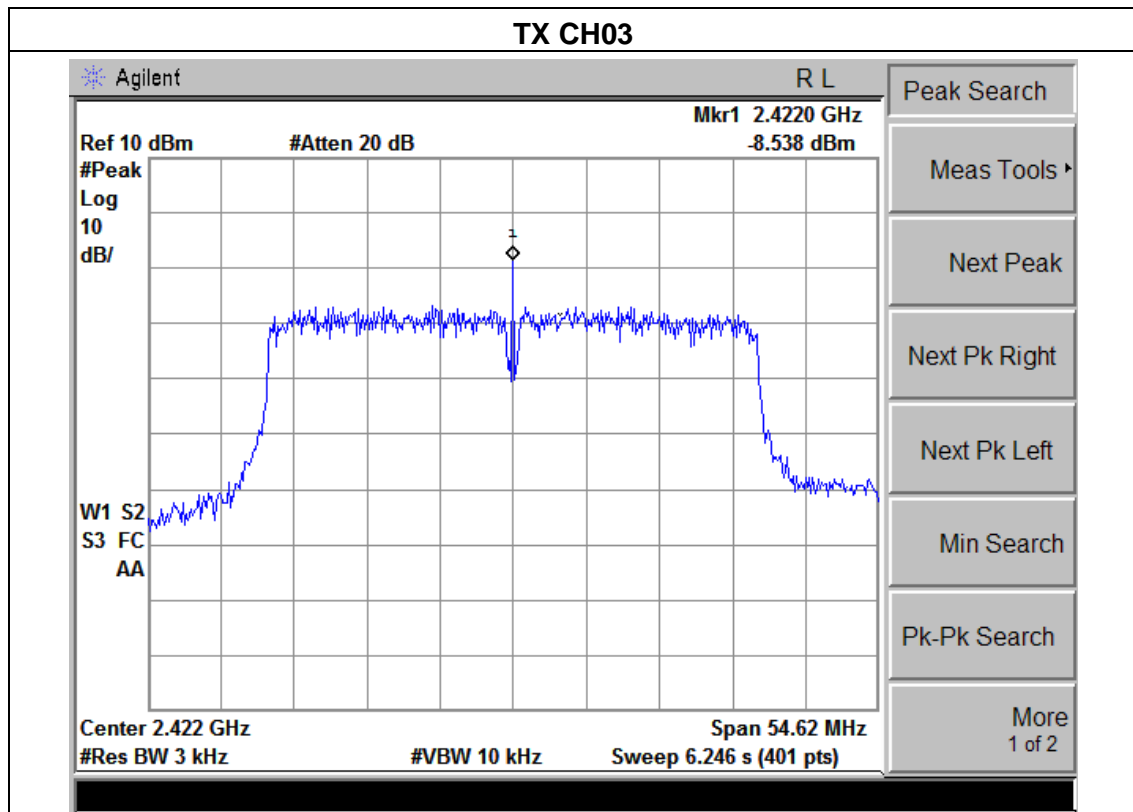

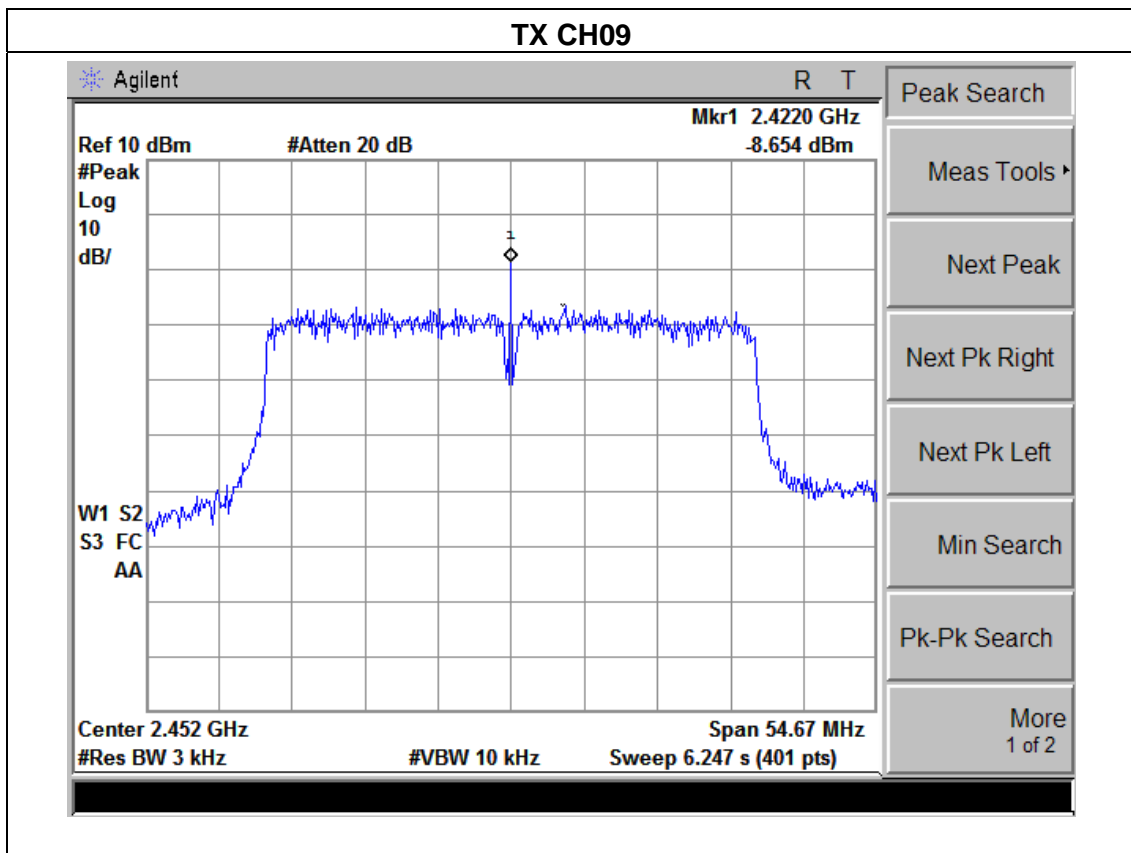
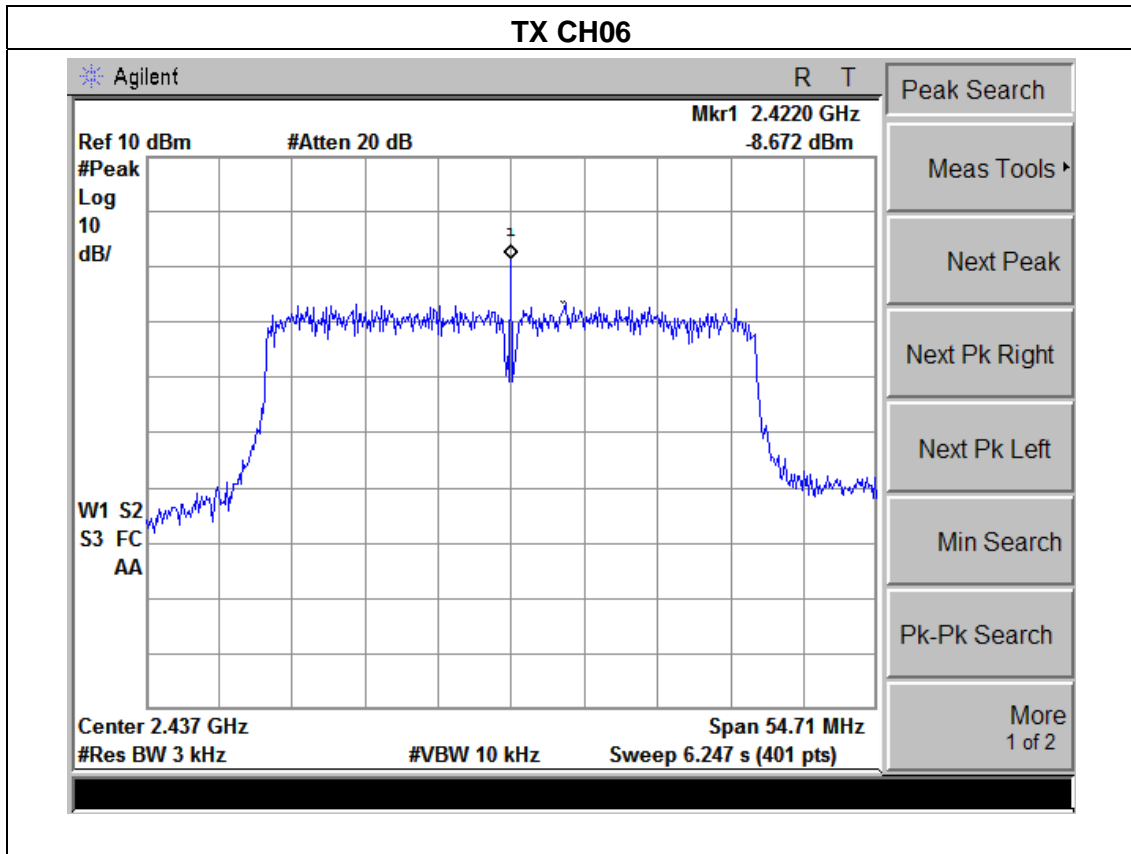

5. BANDWIDTH TEST

5.1 APPLIED PROCEDURES / LIMIT

FCC Part15 (15.247) , Subpart C				
Section	Test Item	Limit	Frequency Range (MHz)	Result
15.247(a)(2)	Bandwidth	$\geq 500\text{KHz}$ (6dB bandwidth)	2400-2483.5	PASS

5.1.1 TEST PROCEDURE

1. Set resolution bandwidth (RBW) = 1-5% or DTS BW, not to exceed 100 kHz.
2. Set the video bandwidth (VBW) $\geq 3 \times$ RBW.
3. Detector = Peak.
4. Trace mode = max hold.
5. Sweep = auto couple.
6. Allow the trace to stabilize.
7. Measure the maximum width of the emission that is constrained by the frequencies associated with the two outermost amplitude points (upper and lower) that are attenuated by 6 dB relative to the maximum level measured in the fundamental emission.

5.1.2 DEVIATION FROM STANDARD

No deviation.

5.1.3 TEST SETUP



5.1.4 EUT OPERATION CONDITIONS

The EUT tested system was configured as the statements of 2.4 Unless otherwise a special operating condition is specified in the follows during the testing.

5.1.5 TEST RESULTS

EUT :	SMART TV BOX	Model Name :	Q10
Temperature :	25 °C	Relative Humidity :	60%
Pressure :	1012 hPa	Test Voltage :	DC 12V from adapter AC 120V/60Hz
Test Mode :	TX b Mode /CH01, CH06, CH11		

Frequency	6dB Bandwidth (MHz)	Channel Separation (MHz)	Result
2412 MHz	11.12	>=500KHz	PASS
2437 MHz	11.18	>=500KHz	PASS
2462 MHz	11.10	>=500KHz	PASS

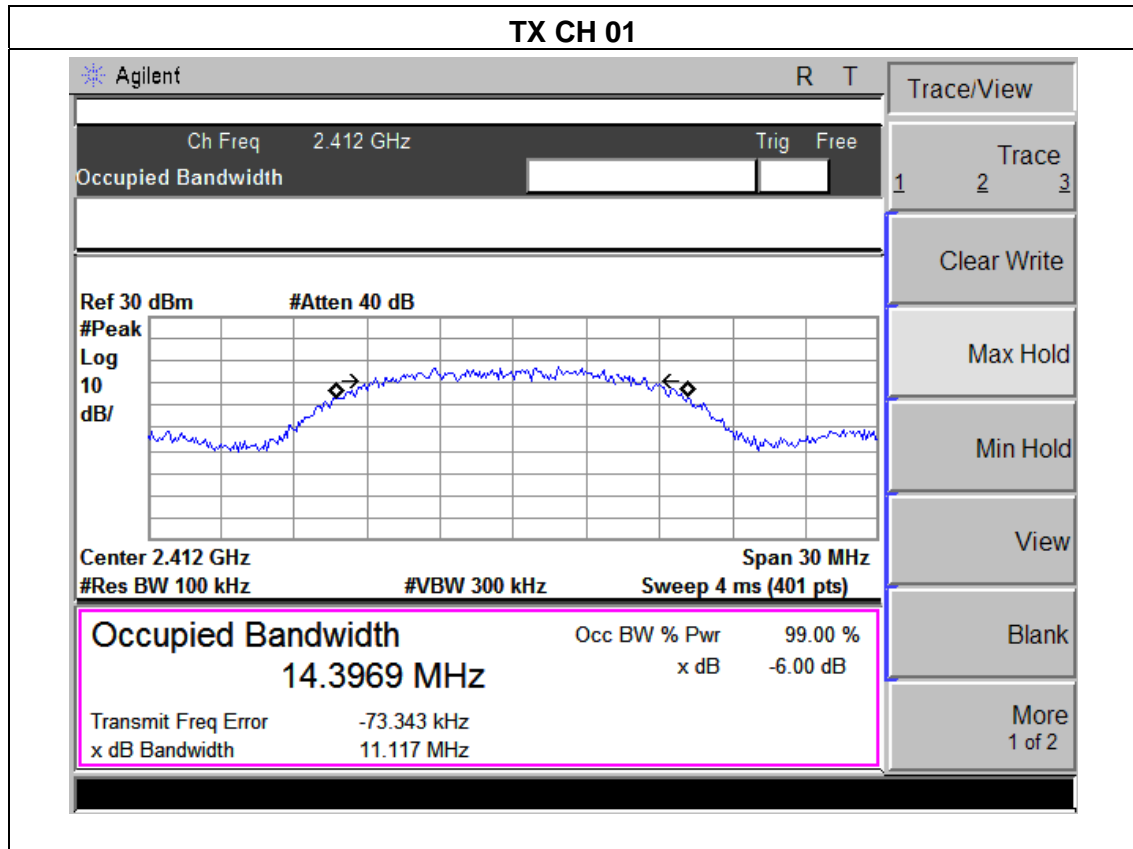

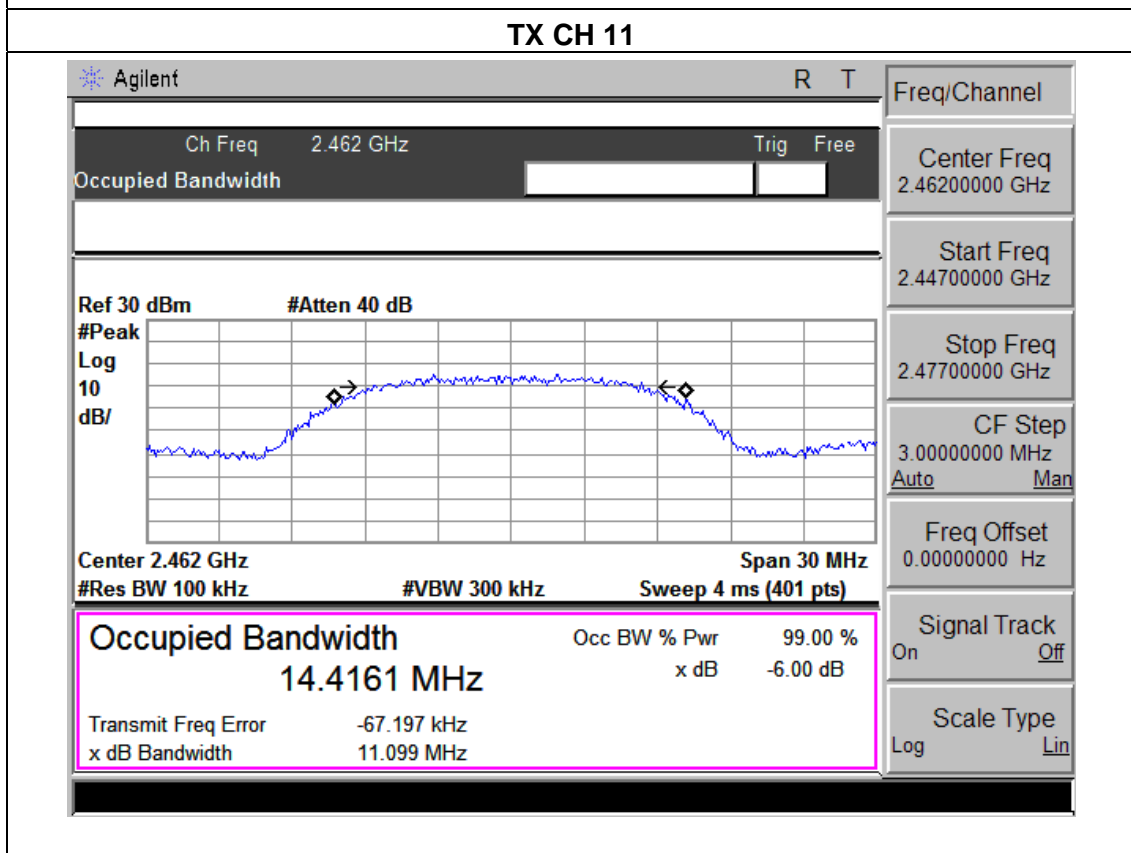
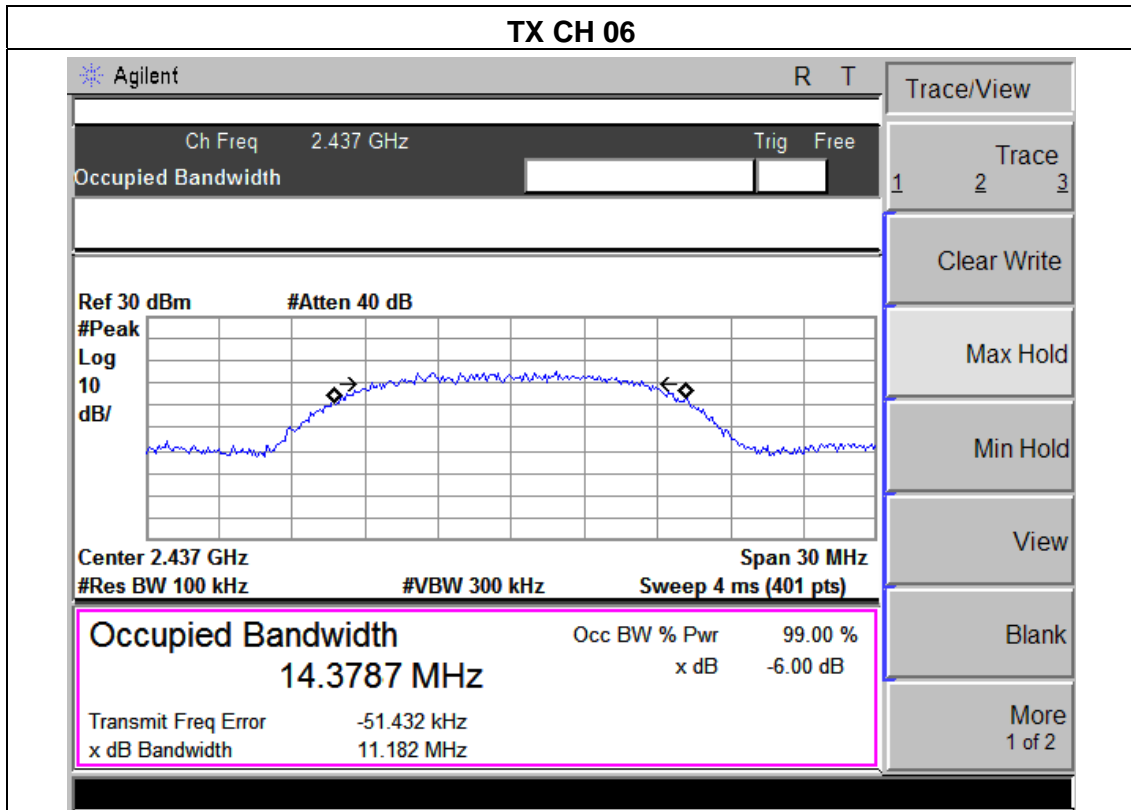

EUT :	SMART TV BOX	Model Name :	Q10
Temperature :	25 °C	Relative Humidity :	60%
Pressure :	1012 hPa	Test Voltage :	DC 12V from adapter AC 120V/60Hz
Test Mode :	TX g Mode /CH01, CH06, CH11		

Frequency	6dB Bandwidth (MHz)	Channel Separation (MHz)	Result
2412 MHz	16.44	>=500KHz	PASS
2437 MHz	16.53	>=500KHz	PASS
2462 MHz	16.52	>=500KHz	PASS

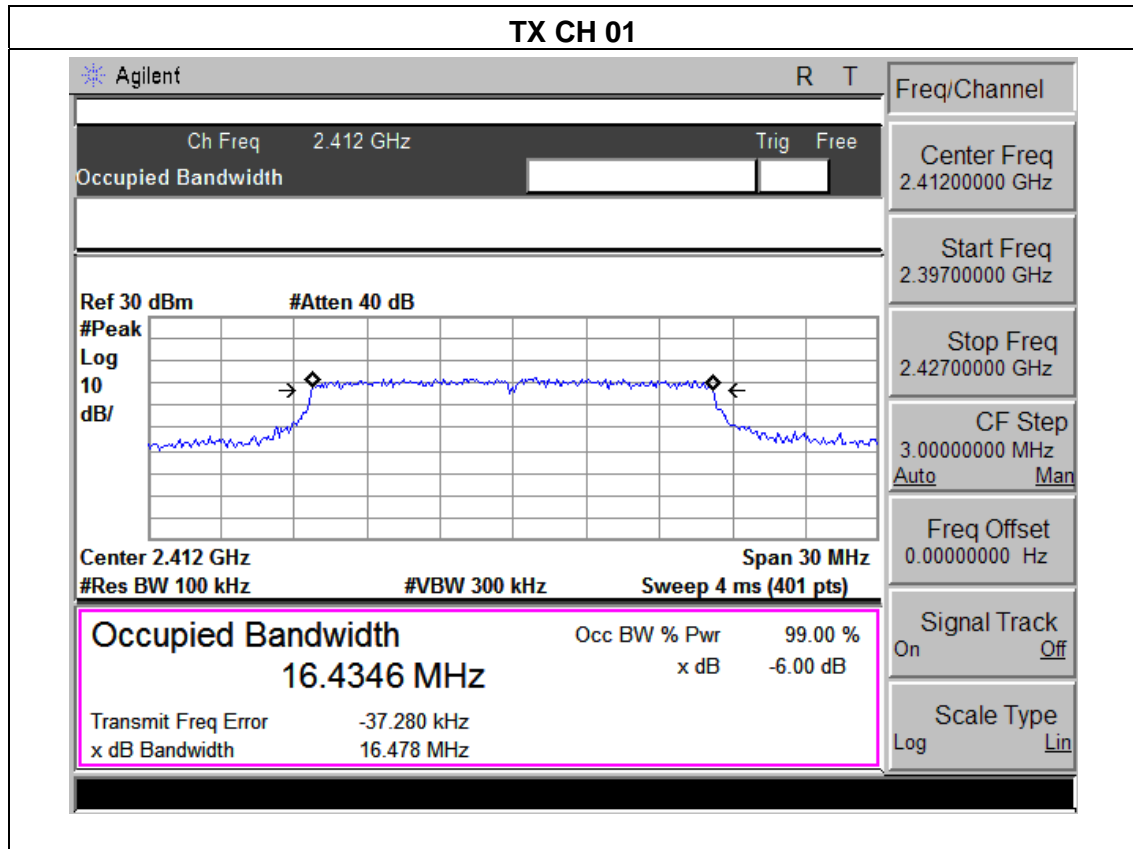

TX CH 06

Agilent R T

Ch Freq 2.437 GHz Trig Free

Occupied Bandwidth [] []

Ref 30 dBm #Atten 40 dB

#Peak
Log
10
dB/

Center 2.437 GHz Span 30 MHz

#Res BW 100 kHz #VBW 300 kHz Sweep 4 ms (401 pts)

Occupied Bandwidth	Occ BW % Pwr	99.00 %
16.4356 MHz	x dB	-6.00 dB
Transmit Freq Error	-33.941 kHz	
x dB Bandwidth	16.534 MHz	

Freq/Channel

Center Freq
2.43700000 GHz

Start Freq
2.42200000 GHz

Stop Freq
2.45200000 GHz

CF Step
3.00000000 MHz
Auto Man

Freq Offset
0.00000000 Hz

Signal Track
On Off

Scale Type
Log Lin

TX CH 11

Agilent R T

Ch Freq 2.462 GHz Trig Free

Occupied Bandwidth [] []

Ref 30 dBm #Atten 40 dB

#Peak
Log
10
dB/

Center 2.462 GHz Span 30 MHz

#Res BW 100 kHz #VBW 300 kHz Sweep 4 ms (401 pts)

Occupied Bandwidth	Occ BW % Pwr	99.00 %
16.4114 MHz	x dB	-6.00 dB
Transmit Freq Error	-40.248 kHz	
x dB Bandwidth	16.516 MHz	

Trace/View

Trace
1 2 3

Clear Write

Max Hold

Min Hold

View

Blank

More
1 of 2

EUT :	SMART TV BOX	Model Name :	Q10
Temperature :	25 °C	Relative Humidity :	60%
Pressure :	1012 hPa	Test Voltage :	DC 12V from adapter AC 120V/60Hz
Test Mode :	TX n(20) Mode /CH01, CH06, CH11		

Frequency	6dB Bandwidth (MHz)	Channel Separation (MHz)	Result
2412 MHz	17.02	>=500KHz	PASS
2437 MHz	17.29	>=500KHz	PASS
2462 MHz	17.59	>=500KHz	PASS

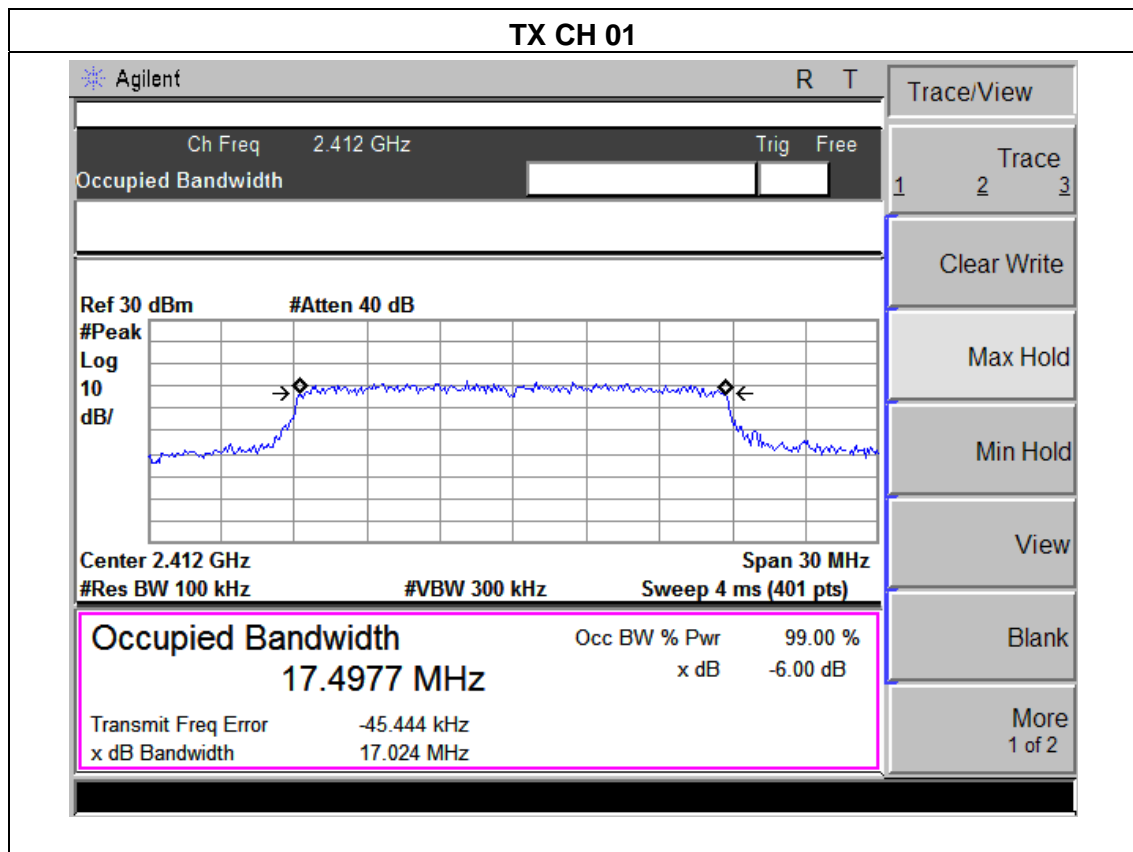

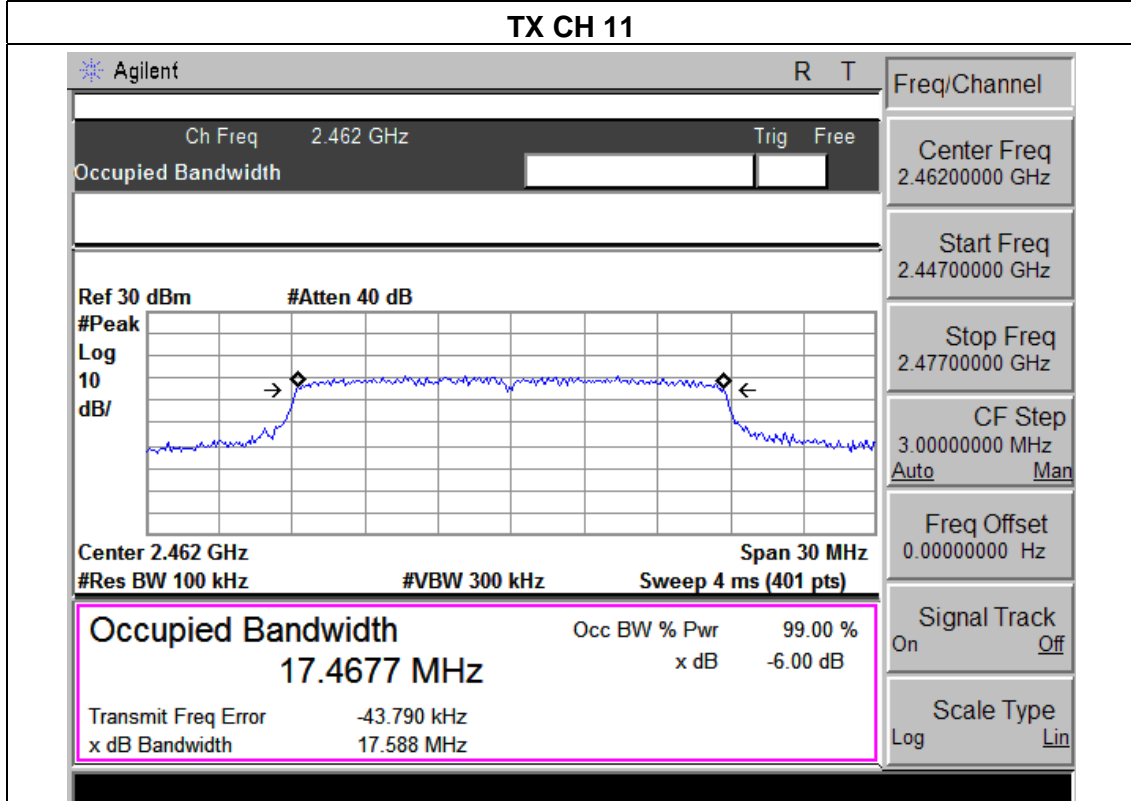
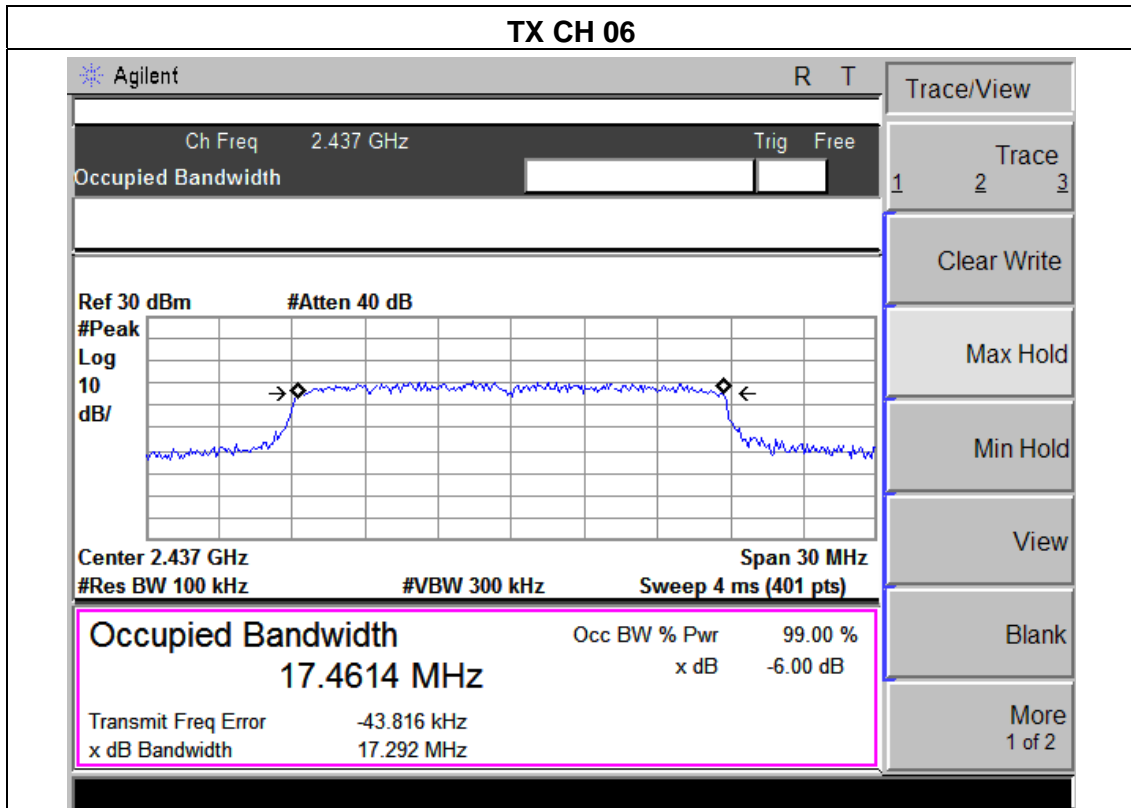

EUT :	SMART TV BOX	Model Name :	Q10
Temperature :	25 °C	Relative Humidity :	60%
Pressure :	1012 hPa	Test Voltage :	DC 12V from adapter AC 120V/60Hz
Test Mode :	TX n(40) Mode /CH03, CH06, CH09		

Frequency	6dB Bandwidth (MHz)	Channel Separation (MHz)	Result
2422 MHz	36.41	>=500KHz	PASS
2437 MHz	36.48	>=500KHz	PASS
2452 MHz	36.36	>=500KHz	PASS

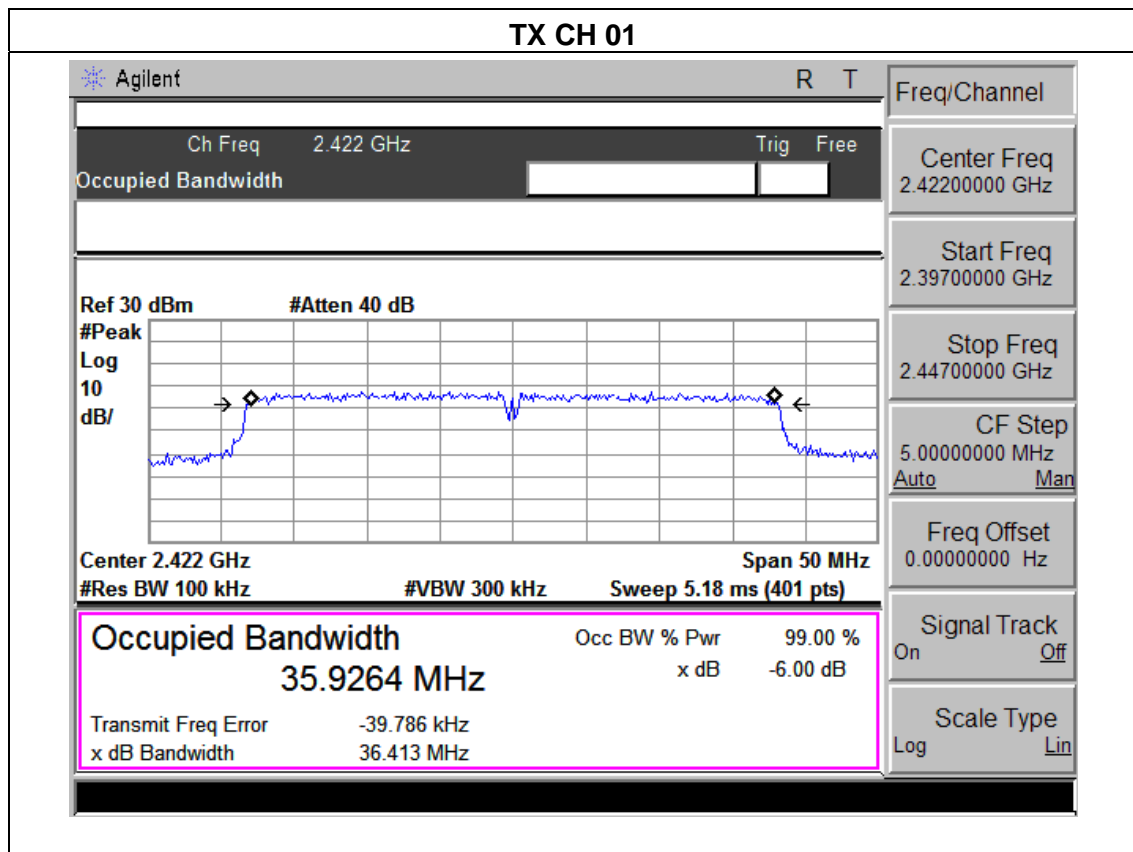

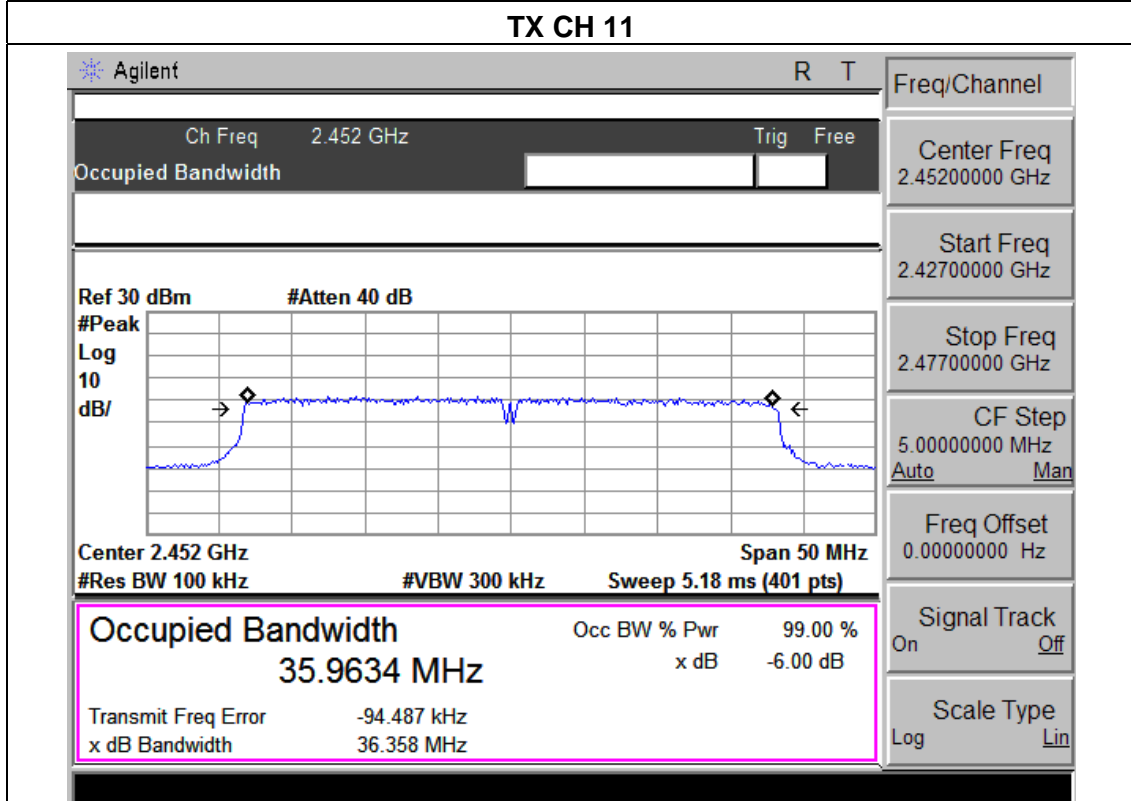
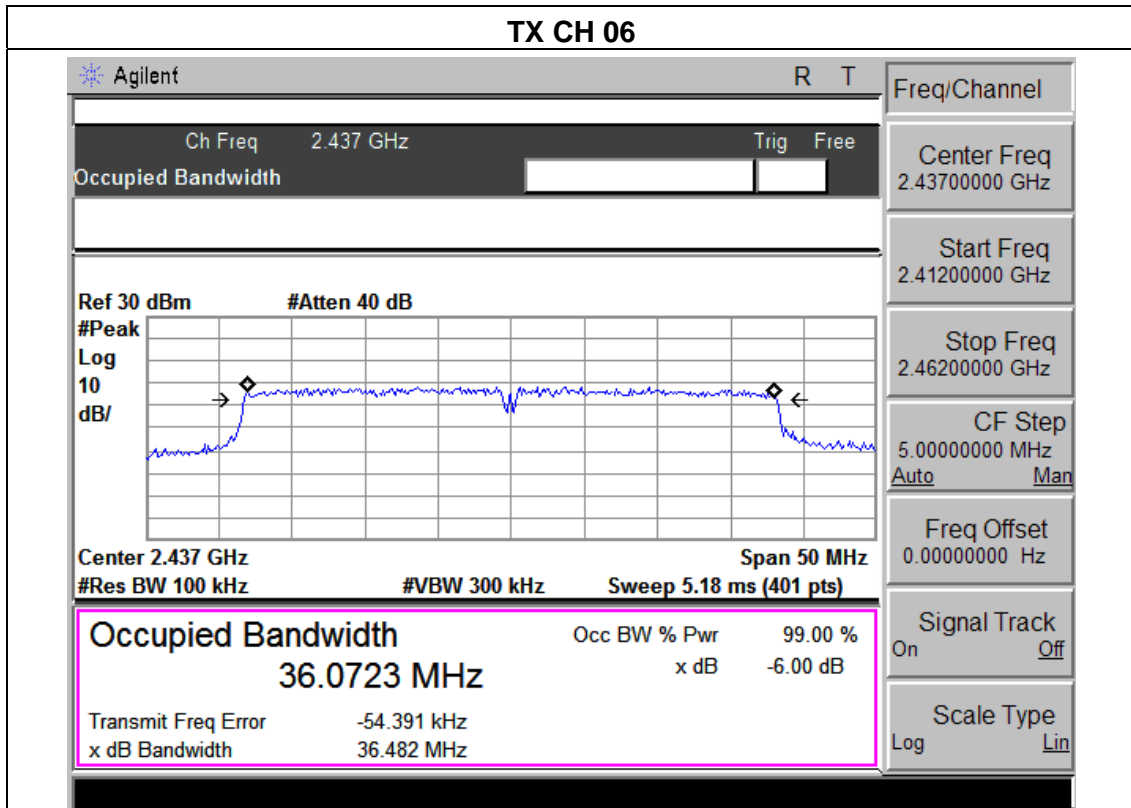

6. PEAK OUTPUT POWER TEST

6.1 APPLIED PROCEDURES / LIMIT

FCC Part15 (15.247) , Subpart C				
Section	Test Item	Limit	Frequency Range (MHz)	Result
15.247(b)(3)	Peak Output Power	1 watt or 30dBm	2400-2483.5	PASS

6.1.1 TEST PROCEDURE

- a. The EUT was directly connected to the Power meter

6.1.2 DEVIATION FROM STANDARD

No deviation.

6.1.3 TEST SETUP

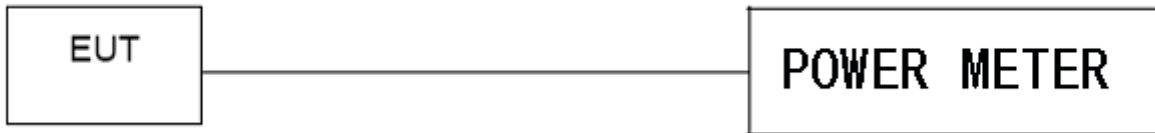

6.1.4 EUT OPERATION CONDITIONS

The EUT tested system was configured as the statements of 2.4 Unless otherwise a special operating condition is specified in the follows during the testing.

6.1.5 TEST RESULTS

EUT :	SMART TV BOX	Model Name :	Q10
Temperature :	25 °C	Relative Humidity :	60%
Pressure :	1012 hPa	Test Voltage :	DC 12V from adapter AC 120V/60Hz
Test Mode :	TX b/g/n Mode /CH01, CH06, CH11		

TX 802.11b Mode

Test Channe	Frequency	Maximum Peak Conducted Output Power	Maximum Conducted Output Power(AV)	LIMIT
	(MHz)	(dBm)	(dBm)	dBm
CH01	2412	18.52	15.88	30
CH06	2437	18.63	15.50	30
CH11	2462	18.69	15.68	30

TX 802.11g Mode

CH01	2412	17.65	14.79	30
CH06	2437	17.44	14.57	30
CH11	2462	17.57	14.67	30

TX 802.11n(20) Mode

CH01	2412	16.58	13.76	30
CH06	2437	16.65	13.53	30
CH11	2462	16.34	13.68	30

TX 802.11n(40) Mode

CH03	2422	15.54	12.87	30
CH06	2437	15.32	12.56	30
CH09	2452	15.74	12.65	30

7. ANTENNA REQUIREMENT

7.1 STANDARD REQUIREMENT

15.203 requirement: For intentional device, according to 15.203: an intentional radiator shall be designed to ensure that no antenna other than that furnished by the responsible party shall be used with the device.

7.2 EUT ANTENNA

The EUT antenna is Integrated(Reserve SMA-type) antenna. It comply with the standard requirement.

8. EUT TEST PHOTO

Radiated Measurement Photos

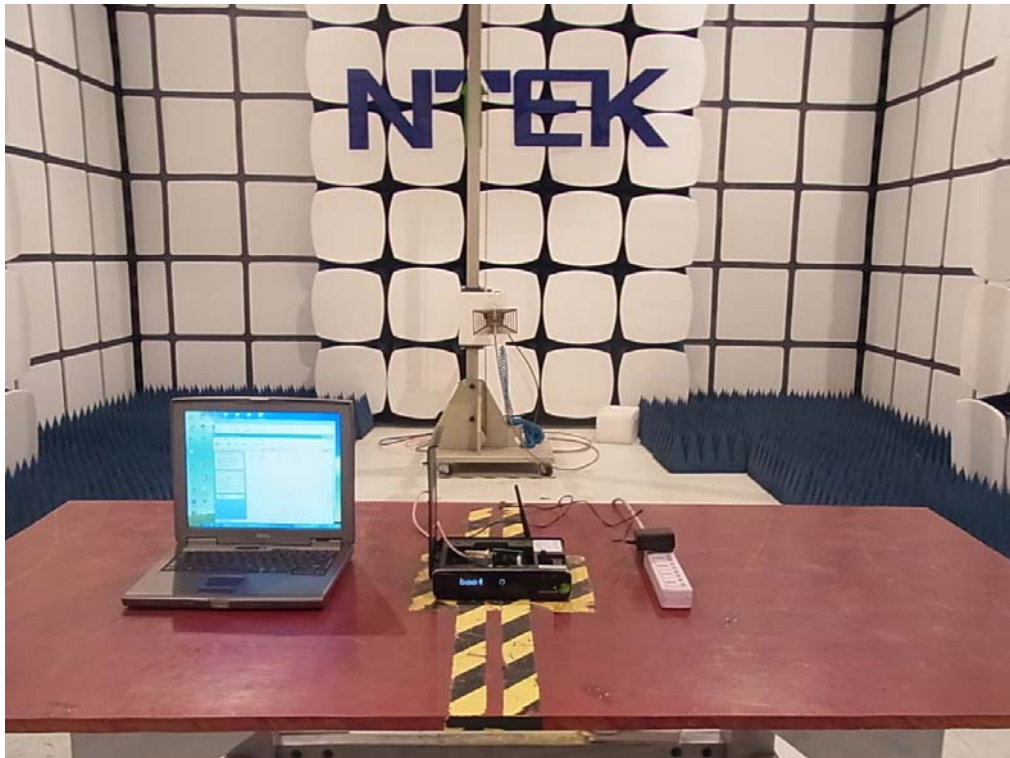
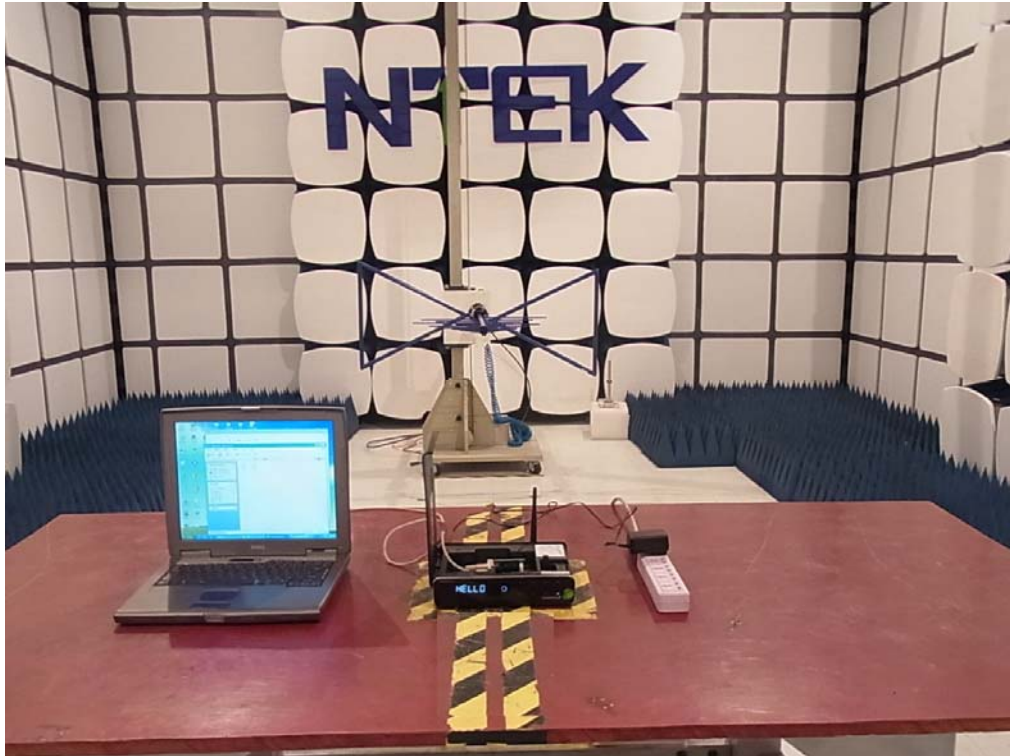

Conducted Measurement Photos

